

# FUJI ELECTRIC

## SPLIT TYPE ROOM AIR CONDITIONER

### WALL MOUNTED type

# SERVICE MANUAL

Models	Indoor unit	Outdoor unit
	RS-7FA	RO-7FA
	RS-7UA	RO-7UA



## C O N T E N T S

SPECIFICATIONS .....	1
REFRIGERANT SYSTEM DIAGRAM .....	4
CIRCUIT DIAGRAM .....	5
INDOOR PRINTED CIRCUIT BOARD CIRCUIT DIAGRAM .....	7
P.C. BOARD LAYOUTS .....	9
DISASSEMBLY ILLUSTRATION .....	11
PARTS LIST .....	16

# S P E C I F I C A T I O N S

TYPE		COOL	COOL & HEAT
INDOOR UNIT		RS-7FA	RS-7UA
OUTDOOR UNIT		RO-7FA	RO-7UA
COOLING CAPACITY	(kW)	2.10 - 2.10	2.10 - 2.10
HEATING CAPACITY	(kW)	—	2.30 - 2.35

## ELECTRICAL DATA

POWER SOURCE	(V)	220 - 240	220 - 240
FREQUENCY	(Hz)	50	50
RUNNING CURRENT	(A)		
	COOLING	3.0 - 3.1	3.7 - 3.8
	HEATING	—	3.4 - 3.6
INPUT WATTS	(kW)		
	COOLING	0.63 - 0.67	0.78 - 0.82
	HEATING	—	0.71 - 0.77
EER	(kW/kW)		
	COOLING	3.33 - 3.13	2.69 - 2.56
	HEATING	—	3.24 - 3.05
MOISTURE REMOVAL	(ℓ /hr)	1.0	1.0
AIR CIRCULATION-HI	(m³/hr)	415	COOL 355 HEAT 370

## COMPRESSOR

TYPE	Hermetic type, Permanent split condenser, 2 pole, Single phase, Induction motor		
CODE	80206335B 220-240V 50Hz	80210035C 220-240V 50Hz	
REFRIGERANT	R410A (g)	600	600

## FAN MOTOR

POWER SOURCE	(V)	220 - 240	220 - 240
INDOOR UNIT	HI-SPEED (r.p.m.)	1,150 - 1,150	COOL 1,230 - 1,230 HEAT 1,280 - 1,280
	MED-SPEED (r.p.m.)	1,080 - 1,080	COOL 1,130 - 1,130 HEAT 1,180 - 1,180
	LO-SPEED (r.p.m.)	1,010 - 1,010	COOL 1,030 - 1,030 HEAT 1,080 - 1,080
	QUIET (r.p.m.)	900 - 900	COOL 940 - 940 HEAT 970 - 970
OUTDOOR UNIT	(r.p.m.)	770 - 800	COOL 770 - 800 HEAT 770 - 800

## DIMENSIONS

INDOOR UNIT	H x W x D (mm)	248 x 808 x 163	248 x 808 x 163
OUTDOOR UNIT		535 x 650 x 250	535 x 695 x 250

## WEIGHTS

INDOOR UNIT	GROSS / NET (kg)	10 / 8	10 / 7.5
OUTDOOR UNIT		27 / 24	28 / 25

## NOISE LEVEL

INDOOR UNIT	HI-SPEED (dB)	37 - 37	COOL 37 - 37	HEAT 37 - 37
	MED-SPEED (dB)	35 - 35	COOL 35 - 35	HEAT 34 - 34
	LO-SPEED (dB)	33 - 33	COOL 33 - 33	HEAT 32 - 32
	SUPER QUIET (dB)	31 - 31	COOL 30 - 30	HEAT 30 - 30
OUTDOOR UNIT	(dB)	42 - 43	COOL 42 - 43	HEAT 44 - 45

## ADDITIONAL CHARGE OF REFRIGERANT

Refrigerant suitable for a piping length of 7.5 m is charged in the outdoor unit at the factory.

When the piping is longer than 7.5 m, additional charging is necessary.

For the additional amount, see the table below.

Pipe length	7.5 m	10 m
Additional refrigerant	None	50 g

Between 7.5 m and 10 m, when using a connection pipe other than that in the table, charge additional refrigerant with 20 g /1 m as the criteria.

[ The maximum length of the piping is 10 m. If the units are further apart than this, correct operation can not be guaranteed. ]

# DIMENSIONS

## INDOOR UNIT

Unit : mm

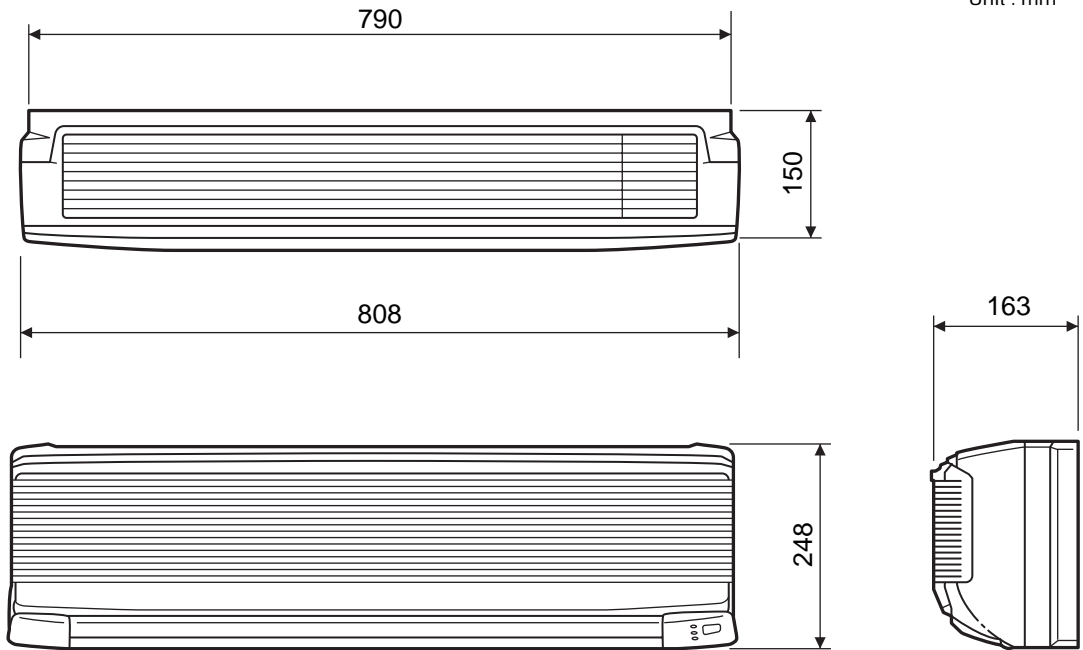

## OUTDOOR UNIT

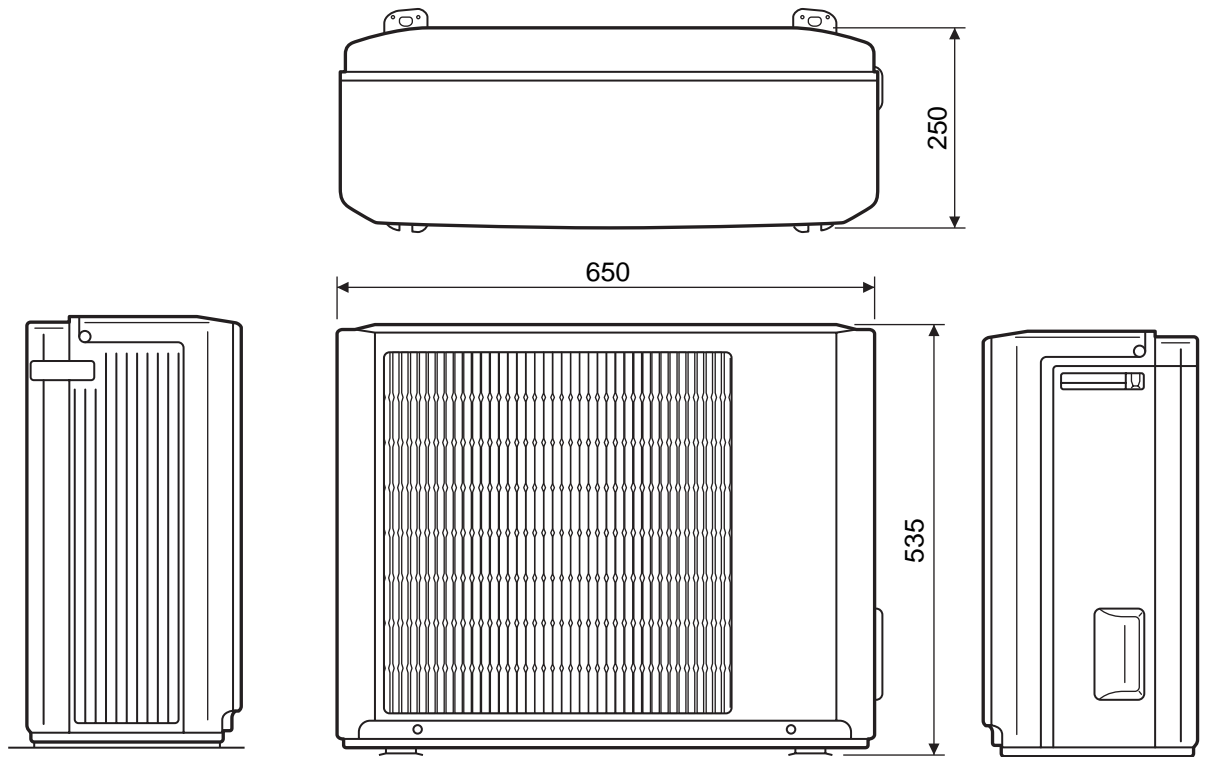

# REFRIGERANT SYSTEM DIAGRAM

## Models : RS-7FA / RO-7FA

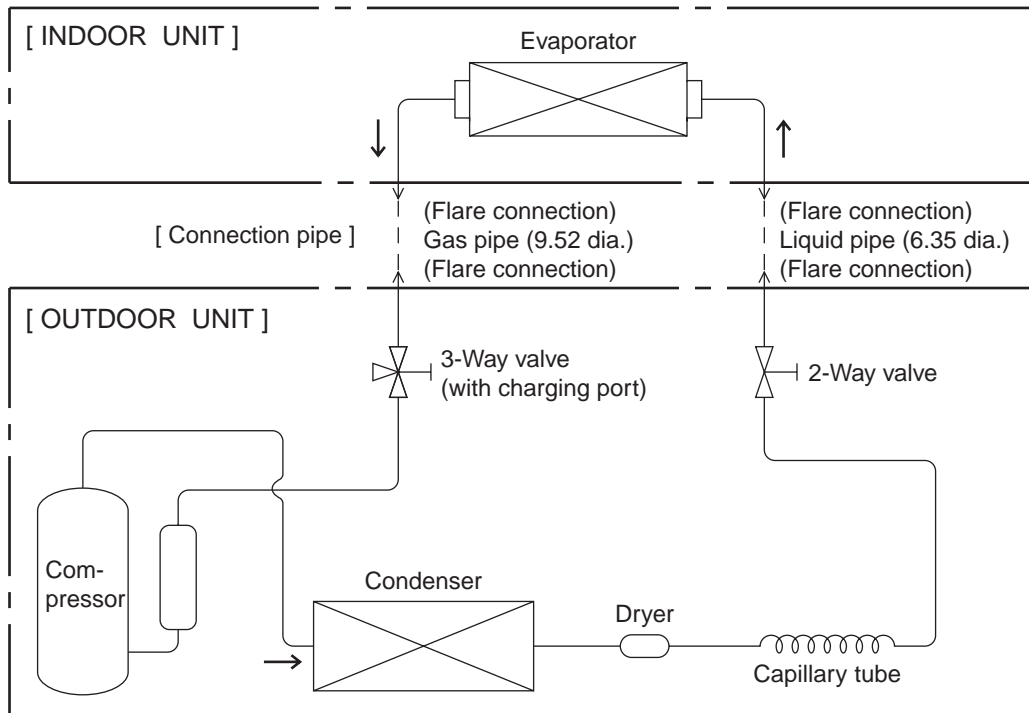

## Models : RS-7UA / RO-7UA

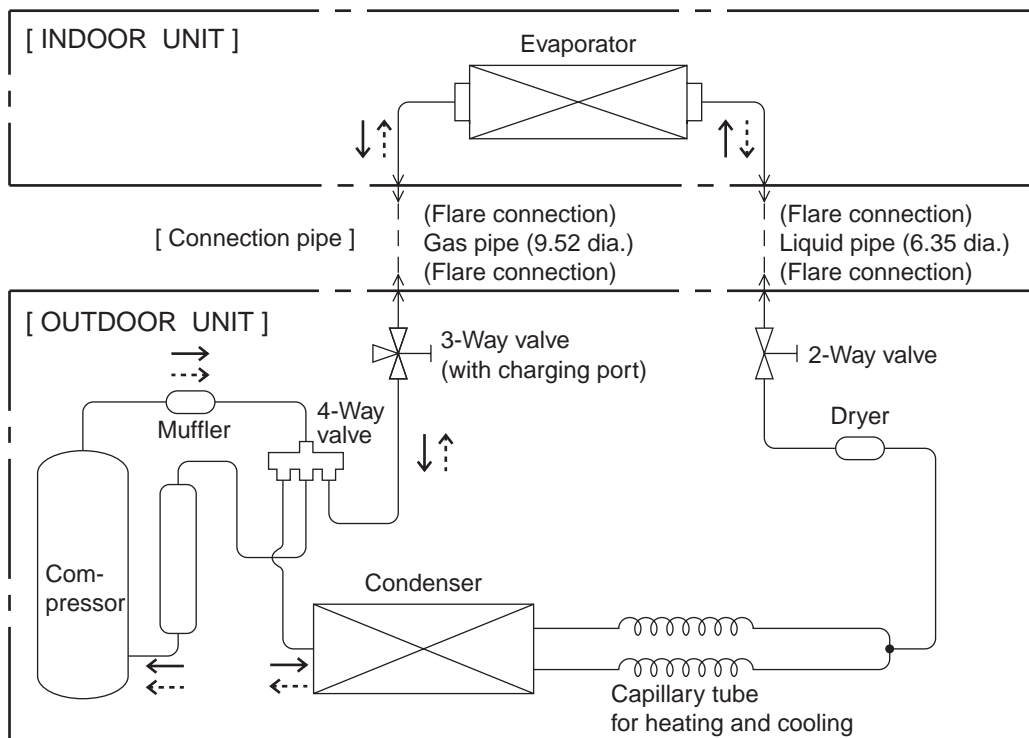

Cooling →  
Heating ···→

# CIRCUIT DIAGRAM

**Models : RS-7FA / RO-7FA**

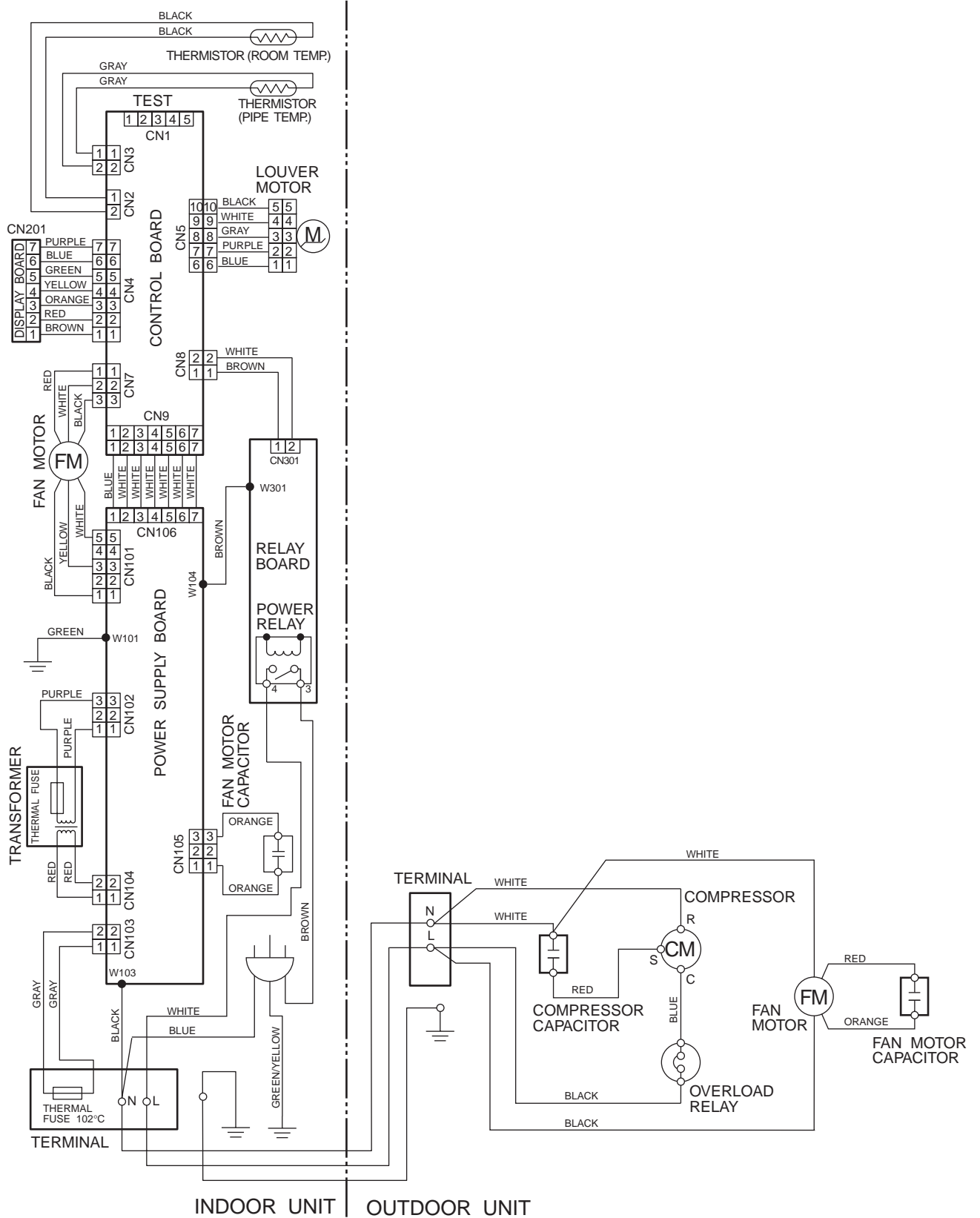

**Models : RS-7UA / RO-7UA**

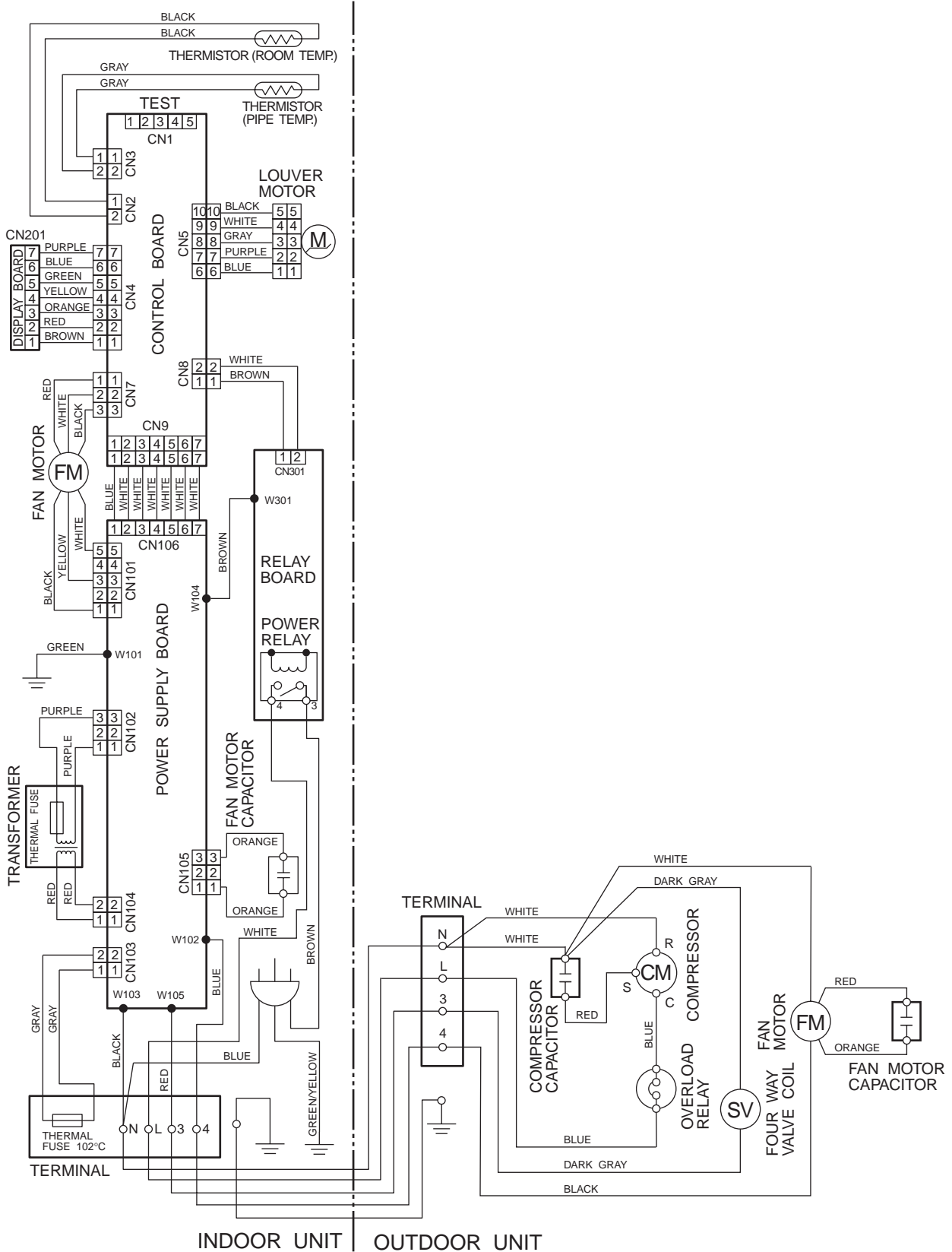

# INDOOR PRINTED CIRCUIT BOARD CIRCUIT DIAGRAM

Model : RS-7FA

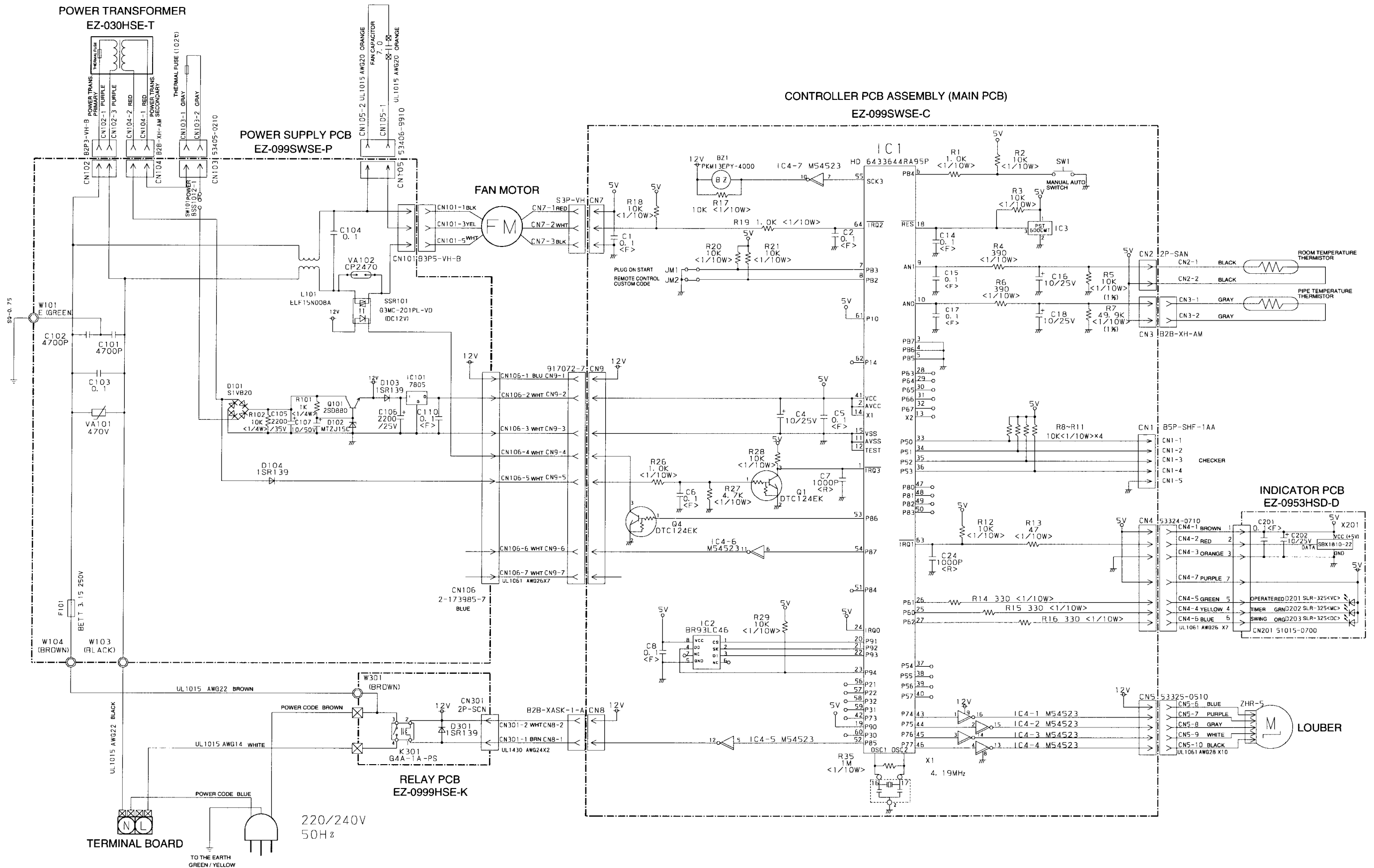



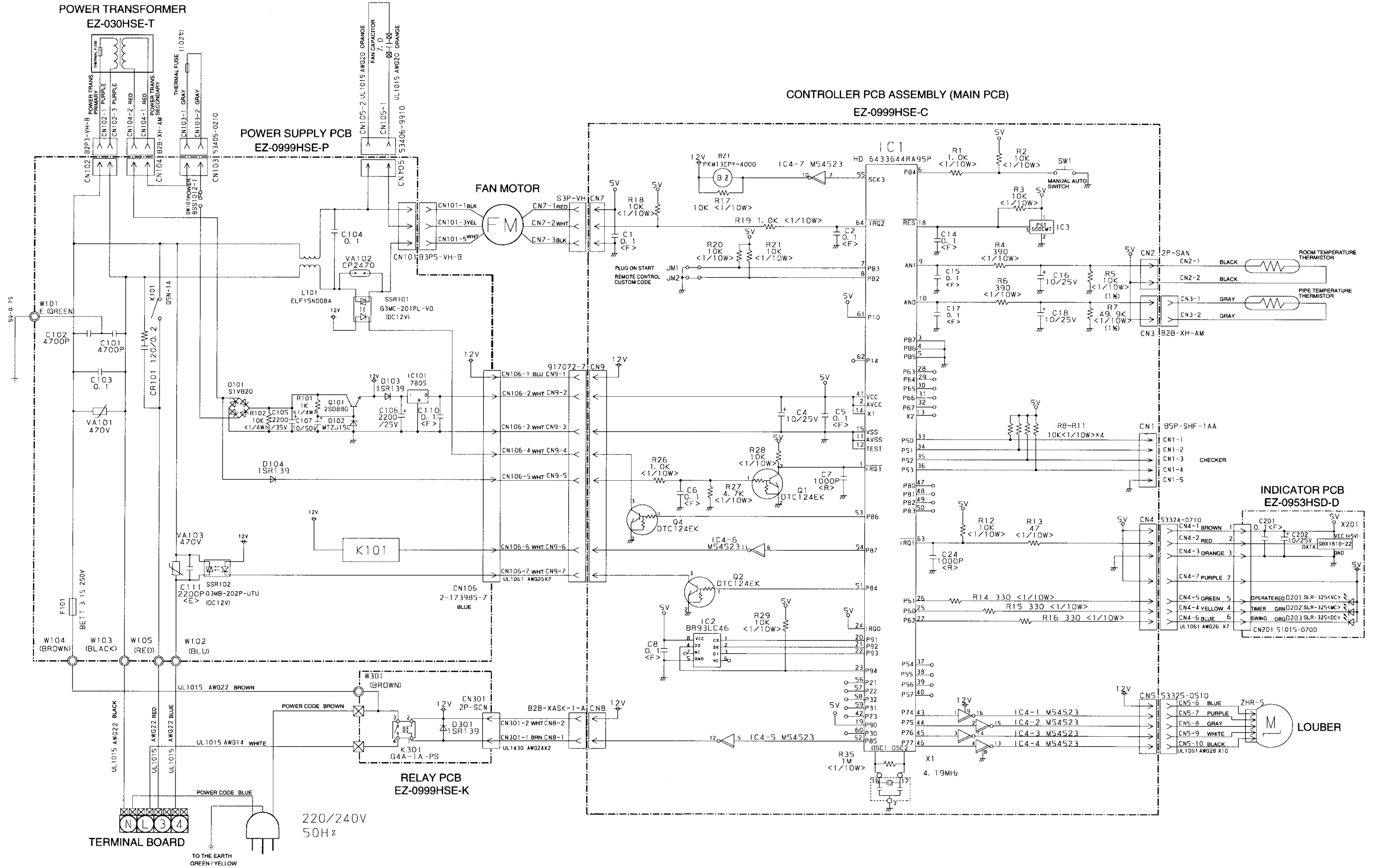

# P.C. BOARD LAYOUTS

## CONTROLLER P.C. BOARD ASSEMBLY (MAIN PCB)

(Viewed from the solder side)

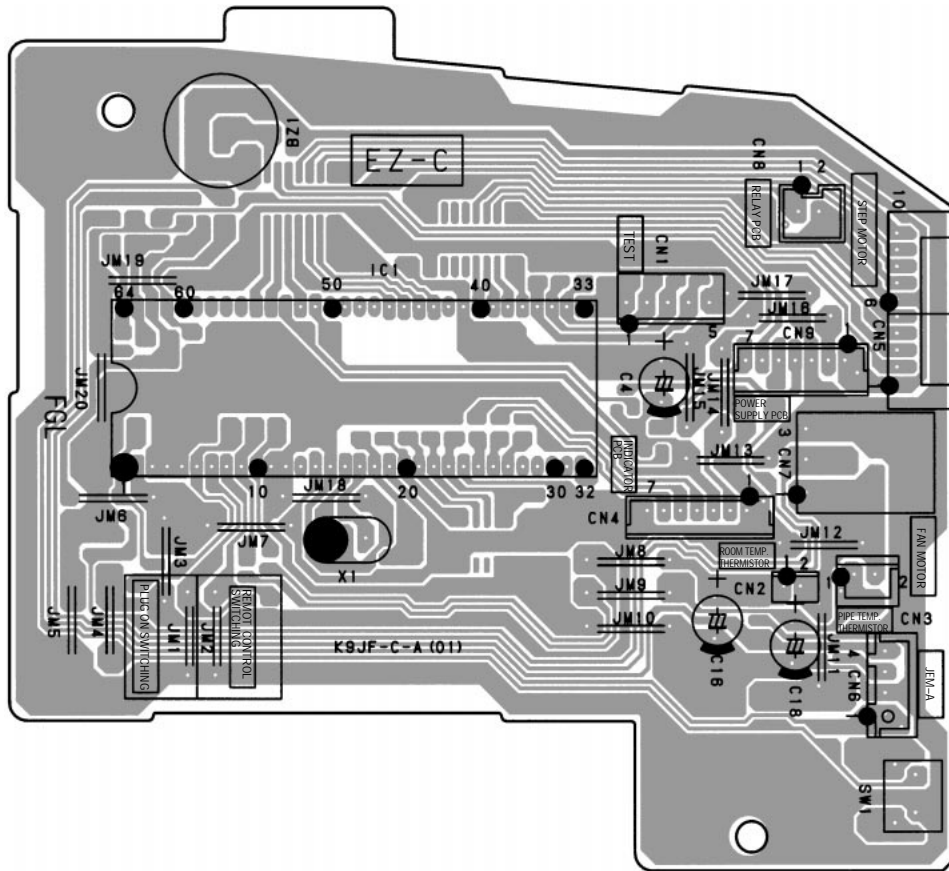

(Viewed from the component side)

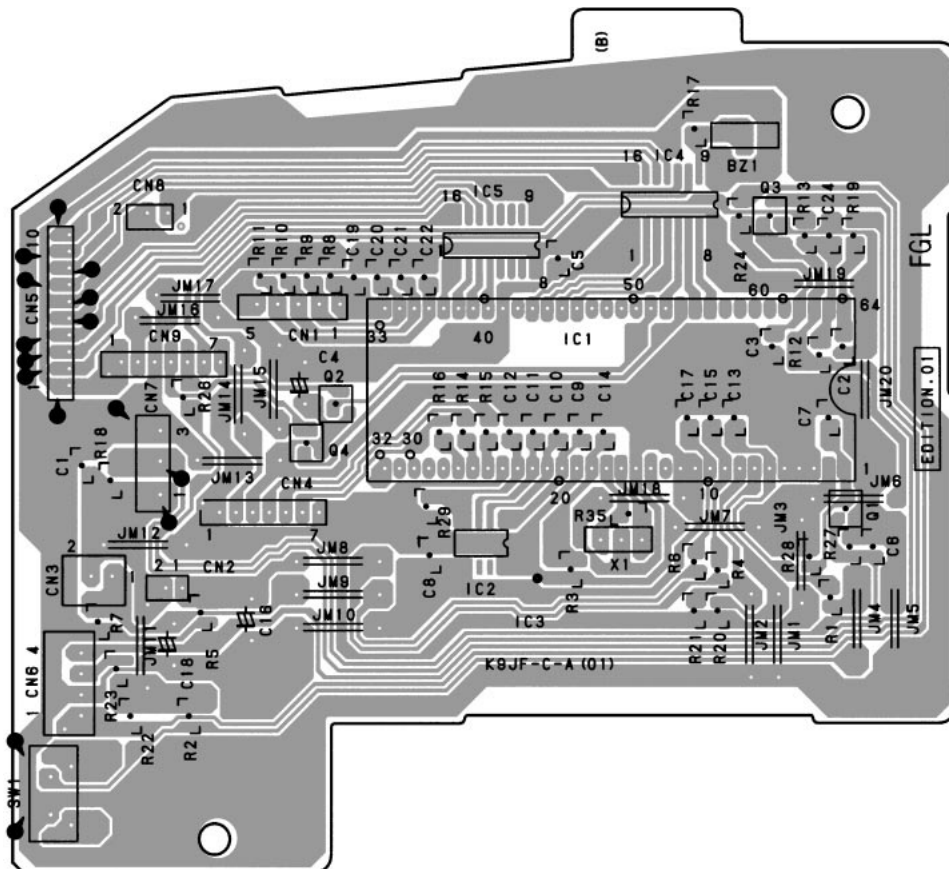

# POWER SUPPLY P.C. BOARD LAYOUTS

(Viewed from the solder side)

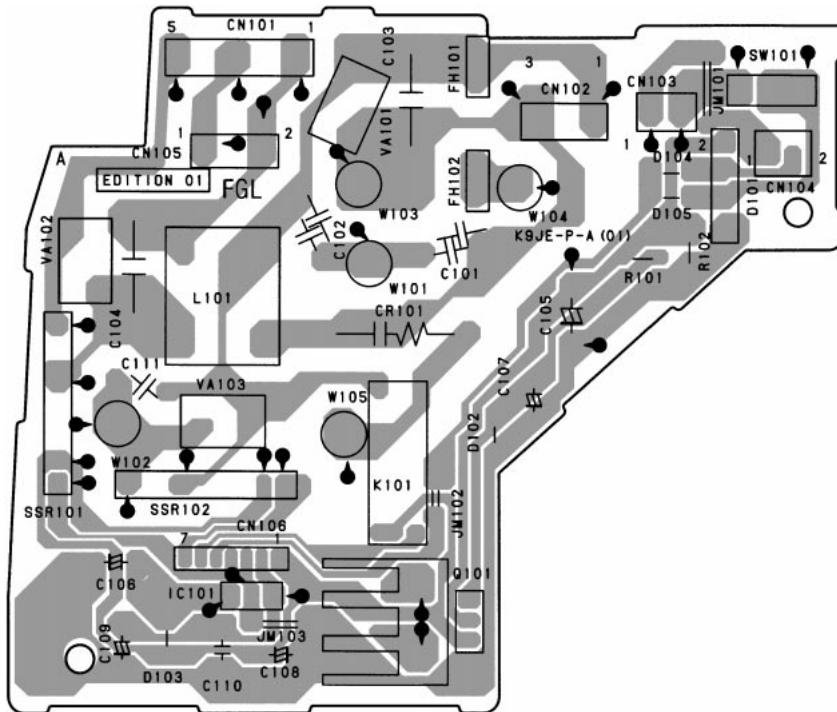

# INDICATOR P.C. BOARD LAYOUTS

(Viewed from the solder side)

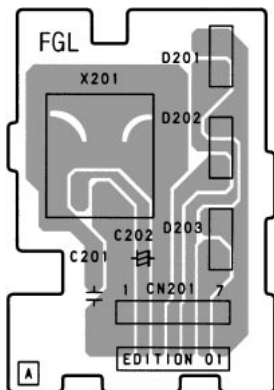

(Viewed from the component side)

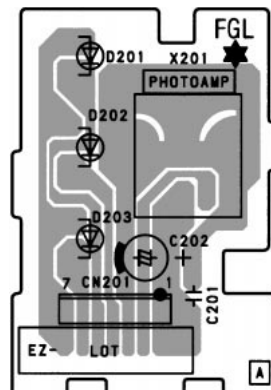

# DISASSEMBLY ILLUSTRATION

Models : RS-7FA  
RS-7UA

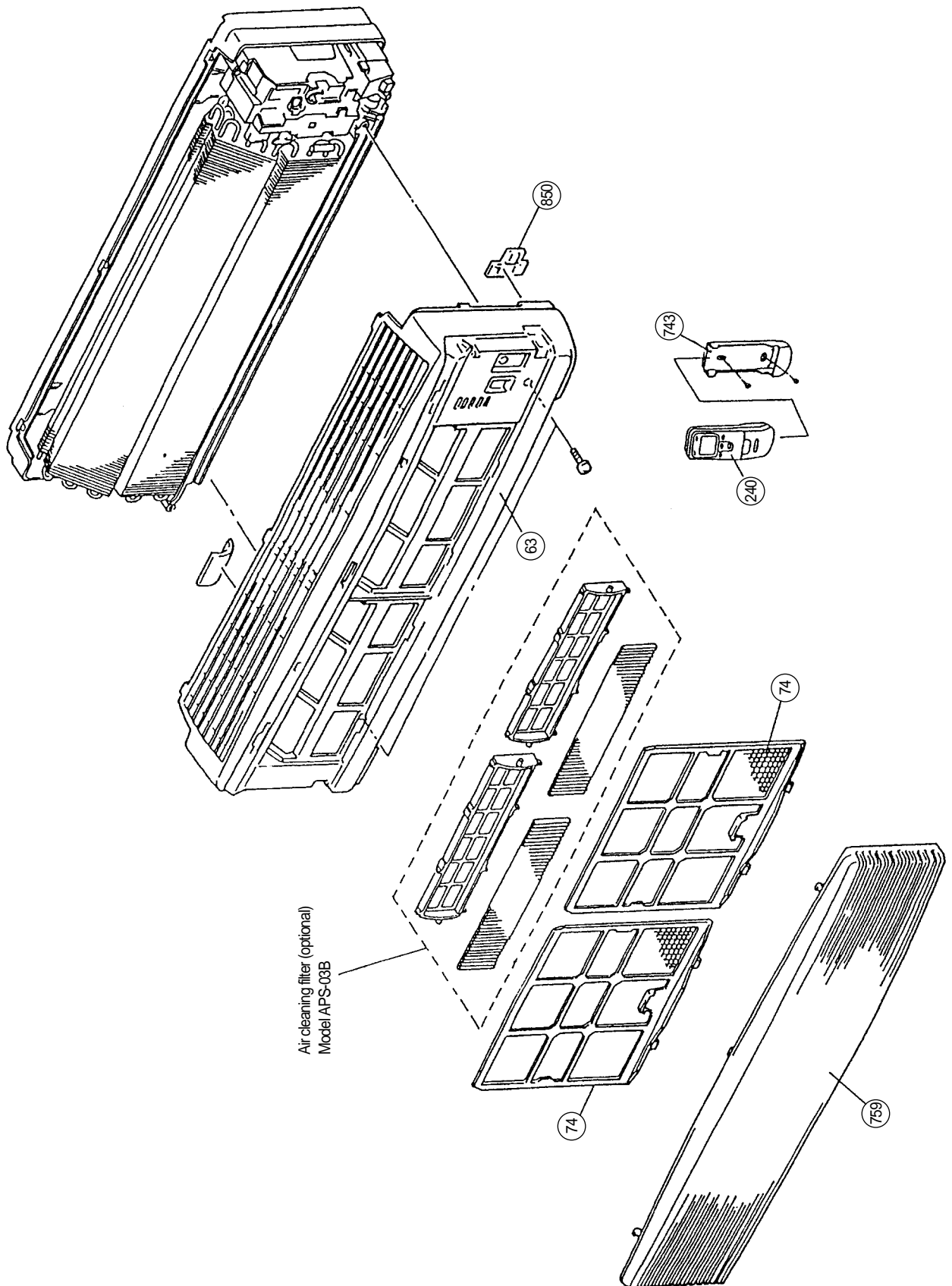

Model : RS-7UA

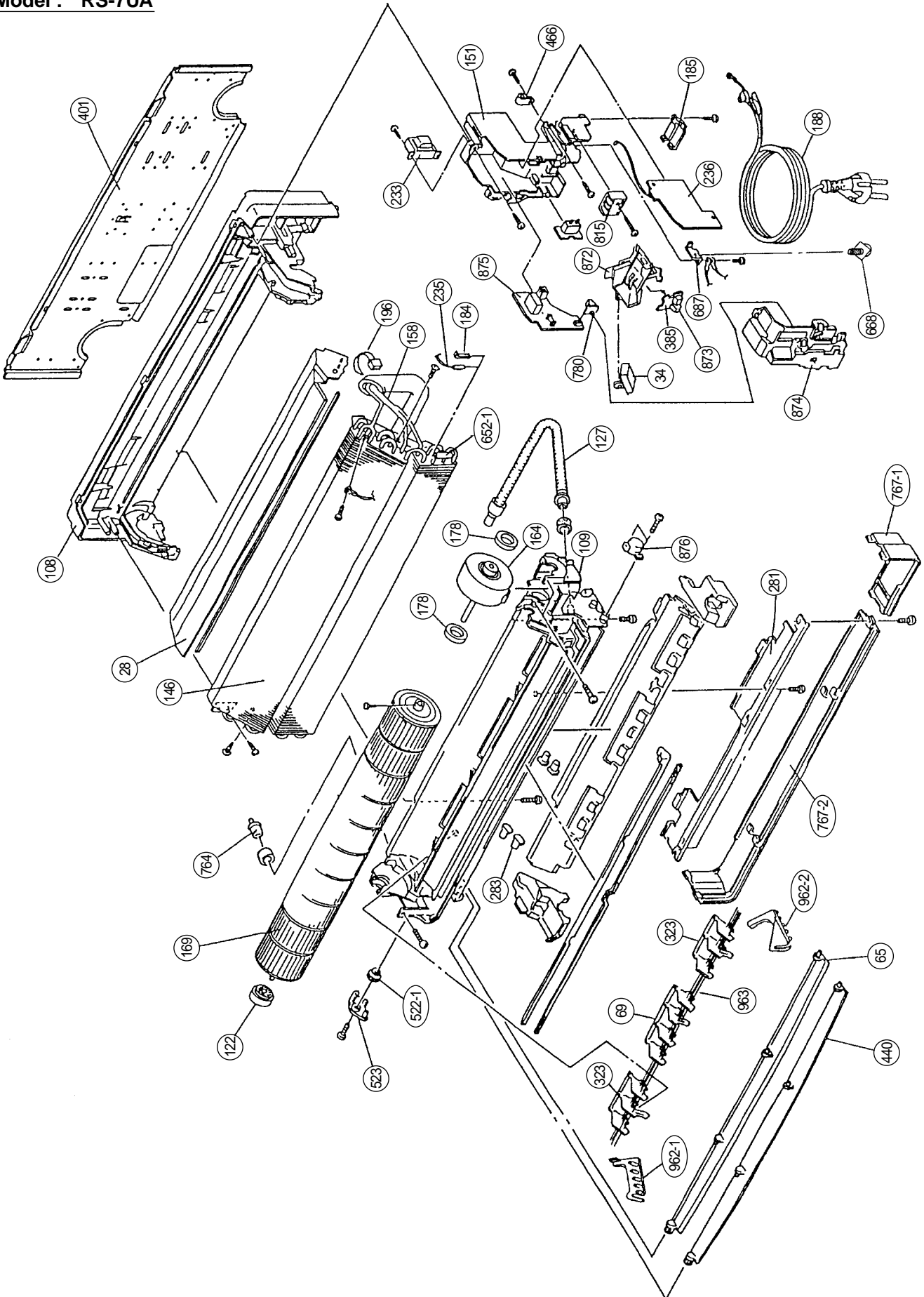

Model : RS-7FA

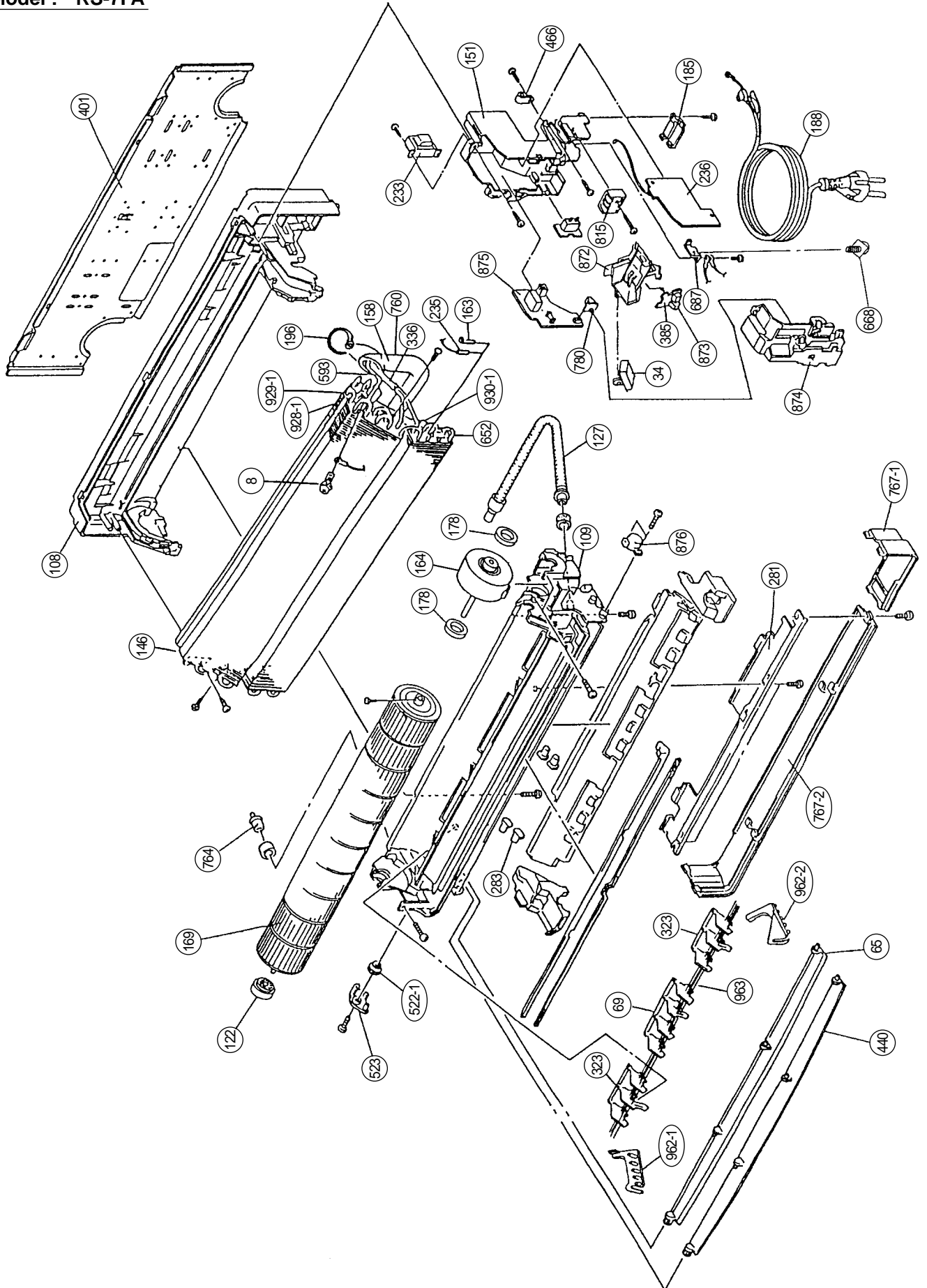

Model : RO-7UA

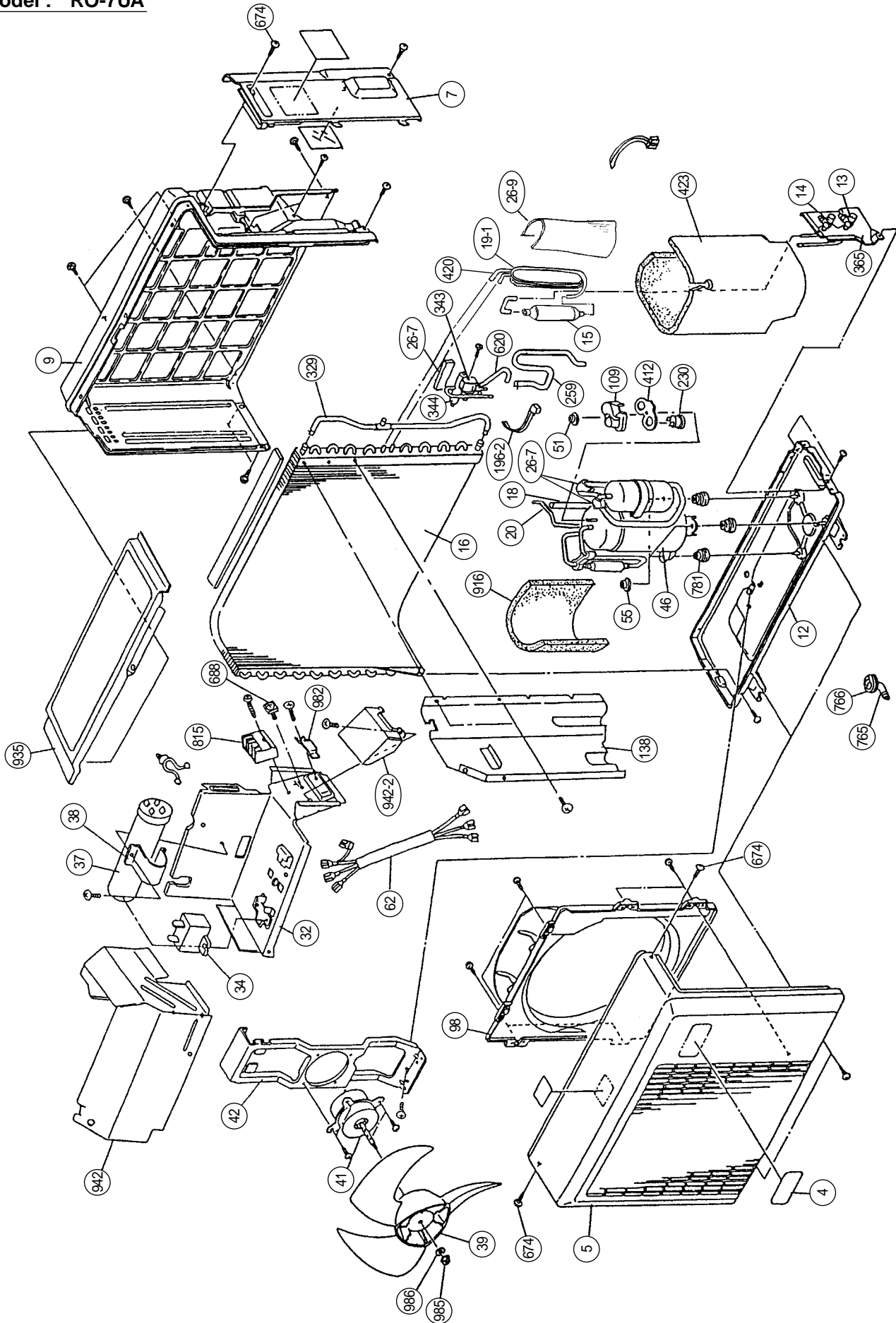

Model : RO-7FA

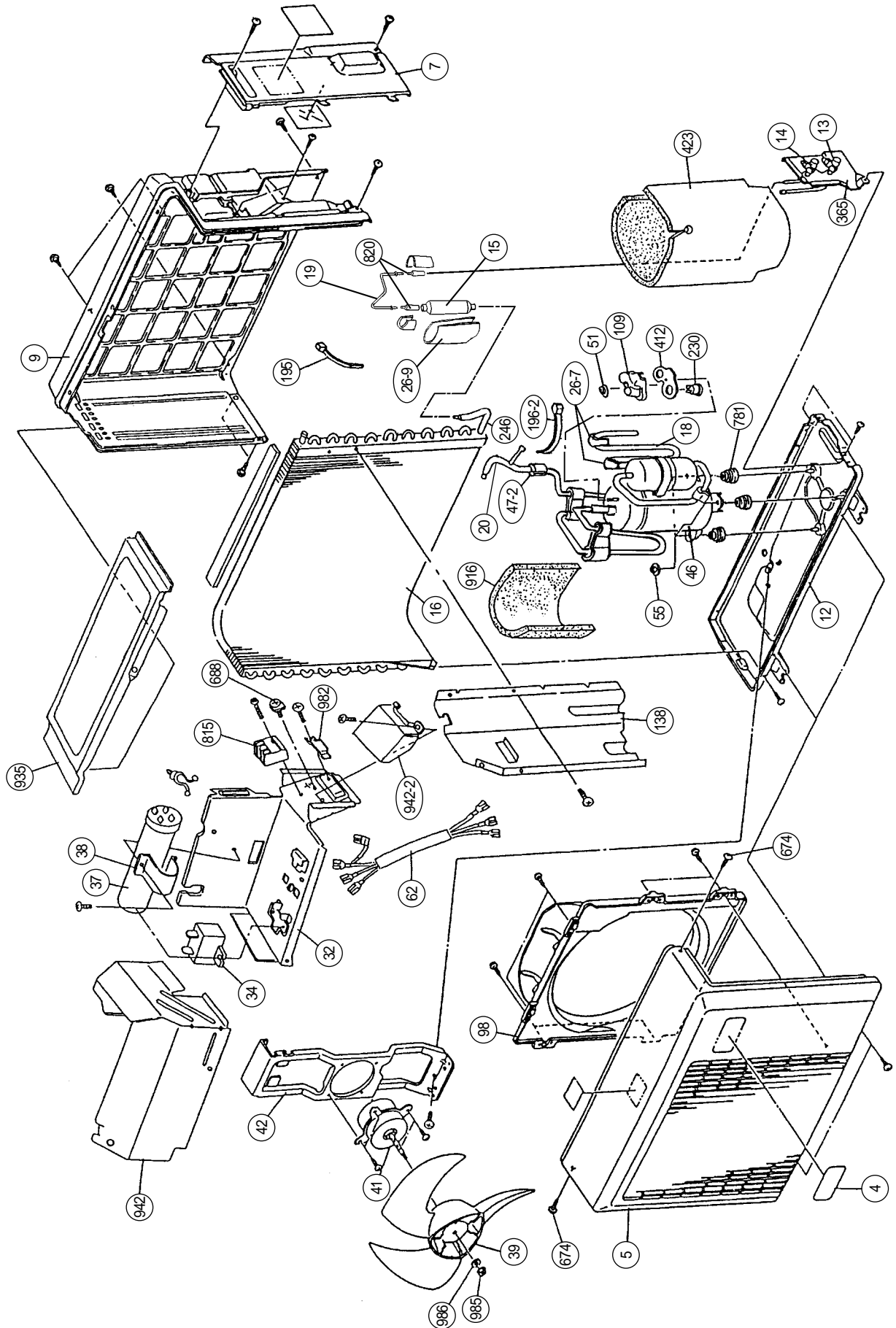



# PARTS LIST

When you order parts, please make a photocopy of this page and fill the number of the parts in the "Order" column.

## INDOOR UNIT

Ref. No.	Description	Part No.		Ord. Q'ty	Ref. No.	Description	Part No.		Ord. Q'ty
		RS-7FA	RS-7UA				RS-7FA	RS-7UA	
28	Blower Cover	9306462000	9306462000		401	Wall Hook Bracket	9304358008	9304358008	
34	Capacitor (Fan Motor)	9702105020	9702105020		440	Flow Control Panel-U	9306057015	9306057015	
63	Front Panel	9306050146	9306050146		466	Clamp NK-4N	313714328805	313714328805	
65	Flow Control Panel-Z	9306058012	9306058012		522-1	Gear-A	9306062002	9306062002	
69	Louver-A	9306055028	9306055028		523	Gear Bracket	9306407001	9306407001	
74	Filter	9305444014	9305444014		652-1	Thermistor Holder Pipe	313714262805	313714262805	
108	Base	9305427017	9305427017		668	Screw w/Washer	313681304205	313681304205	
109	Casing	9306052027	9306052027		687	Earth Terminal	9306483005	9306483005	
122	Shaft Holder-B	9303066010	9303066010		743	Remote Control Holder Case	9305642014	9305642014	
127	Drain Hose Assy	9305550029	9305550029		759	Intake Grille	9306051013	9306051013	
146	Evaporator Assy	9308555045	9308559029		764	Drain Cap Assy	9304150008	9304150008	
151	Control Box	9306763015	9306763015		767-1	Bottom Cover-A	9306053017	9306053017	
158	Connecting Pipe Assy	9306416010	9306699000		767-2	Bottom Cover-B	9306054014	9306054014	
164	Fan Motor Assy-IN	9600249093	9600249093		780	Key Top (Slide Switch)	9303526002	9303526002	
169	Cross-Flow Fan Assy	9307836015	9307836015		815	Terminal	9701955022	9701955039	
178	Motor Cushion-A	9303528006	9303528006		850	Window (Receiver)	9306059019	9306059019	
184	Thermistor Spring	313104262701	313104262701		872	Indicator Case	9306061005	9306061005	
185	Wire Clamp	9305940004	9305940004		873	Lamp Cover	9306060008	9306060008	
188	Power Cord Assy	9701758012	9701758012		874	Control Box Cover	9305977017	9305977017	
196	Clamp SKB-150	313035356905	313035356905		875	Power Supply PCB Assy	9703207020	9703207013	
233	Power Transformer	9701803026	9701803026		876	Step Motor	9305892006	9305892006	
235	Thermistor Assy-Pipe	9702325015	9702325015		928-1	U-Pipe (BB)-D7	9305747009	—	
236	Controller PCB Assy	9703213021	9703213014		929-1	U-Pipe (V)-D7	9305748006	—	
240	Remote Control Unit	9307113048	9307113055		930-1	U-Pipe (W)-D7	9305749003	—	
281	Clamp Metal (Pipe)	9306063009	9306063009		962-1	Gurde Holder-L	9306678012	9306678012	
283	Bushing-A	9303529010	9303529010		962-2	Gurde Holder-R	9306677015	9306677015	
323	Louver-B	9306056025	9306056025		963	Fan Guard	9305751013	9305751013	
385	Indicator PCB Assy	9701700011	9701700011						

When you order parts, please make a photocopy of this page and fill the number of the parts in the "Order" column.

**OUTDOOR UNIT**

Ref. No.	Description	Part No.		Ord. Qty	Ref. No.	Description	Part No.		Ord. Qty
		RO-7FA	RO-7UA				RO-7FA	RO-7UA	
4	Emblem-Rear	9308892010	9308892010						
5	Cabinet Front Panel, Plastic	9306016012	9306016012		230	Clamp SKB-150	---	313035356905	
7	Connector Cover	9306018016	9306018016		246	Overload Relay	9309070004	9309128002	
9	Cabinet Rear Panel, Plastic	9306017019	9306017019		259	Outlet Pipe (Cond.)	9308669001	---	
12	Base Assy, Painted	9304806042	9304806042		329	Muffler-A D28.58	---	9305920006	
13	3-Way Valve	9309119017	9309119017		343	Coupling Pipe Assy	---	9308486011	
14	2-Way Valve	9309118010	9309118010		344	Solenoid Coil	---	9307252013	
15	Dryer	9308440006	9308440006		365	4-Way Valve	---	9308438003	
16	Condenser Assy	9309065017	9309104013		412	Bracket (Valve)	9306020040	9306020040	
18	Suction Pipe	9306781019	9308976000		420	Terminal Gasket (For Comp.)	9351505011	9351505011	
					423	Capillary Assy	---	9309025004	
19	Capillary Tube	9309068001	---		620	Noise Insulation-F	9306937010	9306937010	
19-1	Capillary Tube-A	---	9309027008		674	Inlet Pipe	---	9308988003	
20	Discharge Pipe Assy	9308953001	9309214002			Screw, SUS410T+5014	9307303012	9307303012	
26-7	BR Sheet 30x120x T7	9305039036	9305039036			Screw, Tapping	9306379001	9306379001	
26-9	BR Sheet 180x180x T2	---	9305039067			SUS410T+4010	---	---	
32	Control Box Metal	9306475024	9306475024			Screw, Tapping Coating	9304885009	9304885009	
34	Capacitor (Fan Motor)	9700467045	9700467045			SUS410T+4008	---	---	
37	Capacitor (Running)	9351208011	9306512057		A	Screw (For Earth)	9357297002	9357297002	
38	Clamp Metal (Capacitor)	313468061808	313468061808		688	Screw w/Washer	313681304205	313681304205	
39	Propeller Fan	9306565015	9306565015		765	Drain Pipe (L-type)	---	9301102000	
					766	Drain Pipe Packing	---	9301143003	
41	Fan Motor Assy-Out	9600164235	9600164235		781	Rubber Cushion	9300293013	9300293013	
42	Bracket (Motor)	9306021016	9306021016		815	Terminal-2P	9306489014	---	
46	Compressor Assy	9309069008	9309127005		815	Terminal-4P	---	9306488017	
47-2	Rubber (Discharge Pipe)	313185159802	---		820	Joint Pipe (Capillary)	9308667007	---	
51	Special Nut M5	313199233602	313199233602		916	Noise Insulation-G	9309073005	9309073005	
55	Special Nut M8	313252257701	313252257701		935	Reinforcement Plate	9306473006	9306473006	
62	Wire Assy (Shield)-A	9305695027	9305791026		942	Control Box Cover Metal	9306476007	9306476007	
98	Fan Ring	9306019020	9306019020		942-2	Control Box Cover-B Metal	9305975006	9305975006	
109	Terminal Cover	9302419008	9302419008		982	Cord Clamp, Plastic	9302271002	9302271002	
138	Separate Wall Metal	9306474003	9306474003		985	Special Nut w/Washer	9304902003	9304902003	
195	Clamp SKB-100	313361275805	313361275805		986	Special Washer	9304903000	9304903000	
196-2	Clamp SKB-3MC	9305335008	9305335008						

When you order parts, please make a photocopy of this page and fill the number of the parts in the "Order" column.

**CONTROLLER PCB ASSEMBLY (Ref. No. 236)**

( ) : Reverse cycle model

Ref. No.	Description	Part No.	Ord. Q'ty	Ref. No.	Description	Part No.	Ord. Q'ty
IC1	IC HD6433644RA95P	9702814014		C7,24	Cap. Ceramic 50V 1000pF	0300308509	
IC2	IC BR93LC46RF-E2	0100295016		C4,16,18	Cap. Elec. 25V 10μF	0300328026	
IC3	IC PST600CMT	0101461120		X1	Ceramic Resonator CSTS0419MG06-T2	0400219026	
IC4	Xstr Array M54523FP	0100013023		SW1	Push Switch EVQ-PFE-04R	9700891017	
Q1,(2),4	Xstr DTC124EK	0000517034		BZ1	Buzer PKM13EPY-4000-TF01	9701298013	
R1,19,26	Res. 1kΩ±5%	0200212746		CN1	Plug, PCB B5P-SHF-1AA	0500006069	
R4,6	Res. 390Ω±5%	0200212647		CN2	Thermistor 150-103-86116	9702324018	
R2,3,8-12,17, 18,20,21,28,29	Res. 10kΩ±5%	0200213019		CN3	Plug, PCB B2B-XH-AM	0500005321	
R5	Res. 10kΩ±5%	0200279497		CN4	Plug, PCB 53324-0710	0501052065	
R7	Res. 49.9Ω±1%	0200279824		CN5	Plug, PCB 53325-0510	0501052546	
R13	Res. 47Ω±5%	0200212425		CN7	Plug, PCB S3P-VH	0500011308	
R14,16	Res. 330Ω±5%	0200212623		CN8	Plug, PCB B2B-XASK-1-A	0501045012	
R27	Res. 4.7kΩ±5%	0200212906		CN9	Plug, PCB 917072-7	0501065010	
R35	Res. 1MΩ±5%	0200213491					
C1,2,5,6,8,14, 15,17	Cap. Ceramic 25V 0.1μF	0300266748					

**POWER SUPPLY PCB ASSEMBLY (Ref. No. 875)**

( ) : Reverse cycle model

Ref. No.	Description	Part No.	Ord. Q'ty	Ref. No.	Description	Part No.	Ord. Q'ty
IC101	IC μPC7805AHF	0100008036		(SSR102)	Relay G3MB-202P-UTU	9703291012	
Q101	Xstr 2SD880	0000001014		HT101	Heat Sink B.PUE-16	9701376018	
D101	Diode S1VB20	0000292054		FH101,102	Fuse Holder PFC5000-0502	0500158072	
D102	Diode MTZJ15C	0000852203		CN101	Plug, PCB B3P5-VH-B	0500011735	
D103,104	Diode 1SR139-400	0000353137		CN102	Plug, PCB B2P3-VH-B	0500011728	
C101,102	Cap. Ceramic 4700pF	0300209110		CN103	Plug, PCB 53405-0210	0500940011	
C103,104	Cap. Plastic 250V 0.1μF	0300304075		CN104	Plug, PCB B2B-XH-AM	0500005321	
C105	Cap. Elec. 35V 2200μF	0300331118		CN105	Plug, PCB 53406-9910	0500951048	
C106	Cap. Elec. 25V 2200μF	0300327111		CN106	Wire w/Connector L=100	9701424016	
C107	Cap. Elec. 25V 10μF	0300328026		W101	Wire w/Terminal L=210	9701660018	
C110	Cap. Ceramic 0.1μF	0300988251		(W102)	Wire w/Terminal L=240 BLU	9701802012	
(C111)	Cap. Ceramic 2200pF	0300209097		W103	Wire w/Terminal L=225 BLK	9701657018	
SW101	Slide Switch 8SS1012-1	9701426010		W104	Wire w/Terminal L=150 BRN	9701658015	
VA101,(103)	Varistor TNR10V471K	0000361224		(W105)	Wire w/Terminal L=240 RED	9701802029	
VA102	Arrester CP2470-F	9701835010		(CR101)	CR Absorber REI202-C3.5	0300387016	
F101	Fuse BET 3.15A - 250V	0600222512		(K101)	Relay G5N-1A	9701566013	
L101	Line Filter ELF15N008A	0400165071		JM101	Wire 0.6 mm dia. L=10 mm	9700025016	
R101	Res. Carbon 1/4W 1kΩ±5%	0201038758		JM102	Wire 0.6 mm dia. L=5 mm	9701260010	
R102	Res. Carbon 1/4W 10kΩ±5%	0201005019		JM103	Wire 0.6 mm dia. L=7.5 mm	9701076017	
SSR101	Relay G3MC-201PL-VD	9702430016					







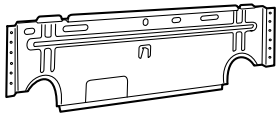

**INDICATOR PCB ASSEMBLY (Ref. No.385)**

**RELAY PCB ASSEMBLY (Ref. No.968)**

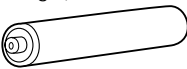
Ref. No.	Description	Part No.	Ord. Q'ty
D201	Diode SLR-325VC RED	0000813259	
D202	Diode SLR-325MC GRN	0000813242	
D203	Diode SLR-325DC ORG	0000813235	
C201	Cap. Ceramic 0.1μF	0300988251	
C202	Cap. Elec. 25V 10μF	0300504413	
X201	Remote Control Amplifier SBX1810-22	0101525129	
CN201	Wire w/Connector L=250 Lamp Cover	9701397020 9306060008	

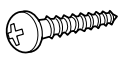
Ref. No.	Description	Part No.	Ord. Q'ty
D301	Diode 1SR139-400	0000353137	
K301	Relay G4A-1A-PS	9701024018	
CN301	Wire w/Connector L=140	9701279012	

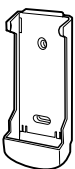
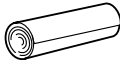
# STANDARD ACCESSORIES

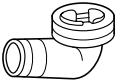
Name and Shape	Part No.	
	RS-7FA	RS-7UA
Wall hook bracket 	9304358008	9304358008
Remote control unit 	9307113062	9307113079
Battery (penlight) 	0600185534	0600185534
Cable mark 	—————	9301385007
Tapping screw (big) (ø4 x 20) 	301141164200	301141164200
Tapping screw (small) (ø3 x 12) 	301141533125	301141533125
Remote control unit holder 	9305642014	9305642014
Cloth tape 	9308117007	9308117007
Hexagon wrench 	9351228019	9351228019
Drain pipe (Including drain packing) 	—————	9303029015



MANUFACTURER :

**Fuji Denki Sosetsu Co., Ltd.**

Tokyo, Japan