

# FUJII ELECTRIC

## SPLIT TYPE ROOM AIR CONDITIONER WALL MOUNTED type

# SERVICE MANUAL

Models	Indoor unit	Outdoor unit
	RS-17E	RO-17E



### C O N T E N T S

SPECIFICATIONS .....	1
REFRIGERANT SYSTEM DIAGRAM .....	2
CIRCUIT DIAGRAM .....	3
DISASSEMBLY ILLUSTRATION .....	7
PARTS LIST .....	13

# S P E C I F I C A T I O N S

INDOOR UNIT		RS - 17E
OUTDOOR UNIT		RO - 17E
COOLING CAPACITY	(kW)	4.75 - 4.90

## ELECTRICAL SPECIFICATIONS

POWER SUPPLY	(V)	220 - 240
FREQUENCY	(Hz)	50
RUNNING CURRENT	(A)	8.6 - 8.4
INPUT	(kW)	1.88 - 1.98
EER	(W/W)	2.53 - 2.47
MOISTURE REMOVAL	( ℓ /hr)	2.1
AIR CIRCULATION - Hi	(m³/hr)	560

## COMPRESSOR

TYPE	Hermetic type, Permanent split condenser, 2 pole, Single phase, induction motor
CODE	PE33VPEM

## FAN MOTOR

		INDOOR UNIT	OUTDOOR UNIT
MODEL		RS - 17E	RO - 17E
TYPE		MFA - 17AT	MFB - 247FB
POWER SUPPLY	(V)	220 - 240	
FAN SPEED	HI-SPEED ( r.p.m. )	1,300	720
	MED-SPEED ( r.p.m. )	1,210	
	LO-SPEED ( r.p.m. )	1,110	

## DIMENSIONS

HEIGHT x WIDTH x DEPTH	(mm)	285(H) x 900(W) x 172(D)	700(H) x 900(W) x 350(D)
------------------------	------	--------------------------	--------------------------

## WEIGHT

GROSS WEIGHT / NET WEIGHT	(kg)	13 / 10	71 / 59
---------------------------	------	---------	---------

## REFRIGERANT CHARGING

PIPE LENGTH	16 ft. ( 5m )	23 ft. ( 7 m )	33 ft. ( 10 m )	49 ft. ( 15 m )	66 ft. ( 20 m )
FULL CHARGE AMOUNT	44.1 oz. ( 1,250 g )	44.8 oz. ( 1,270 g )	45.9 oz. ( 1,300 g )	47.6 oz. ( 1,350 g )	49.4 oz. ( 1,400 g )

Note : Between 5m and 20m, when using a connection pipe other than that in the table, charge additional refrigerant with 0.35 oz.(10g) / 3.3ft.(1m) as the criteria.

# REFRIGERANT SYSTEM DIAGRAM

Models : RS-17E / RO-17E

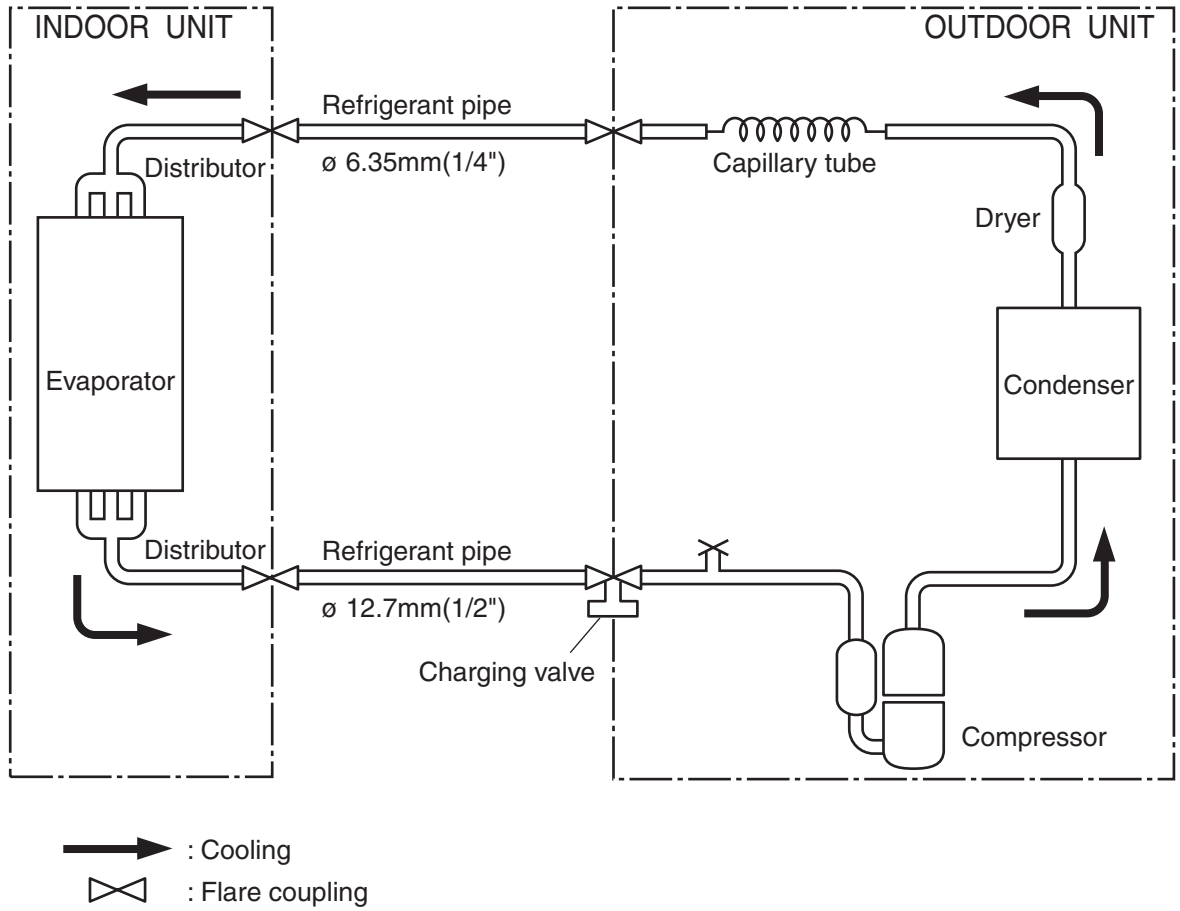

# CIRCUIT DIAGRAM

**Models : RS-17E / RO-17E**

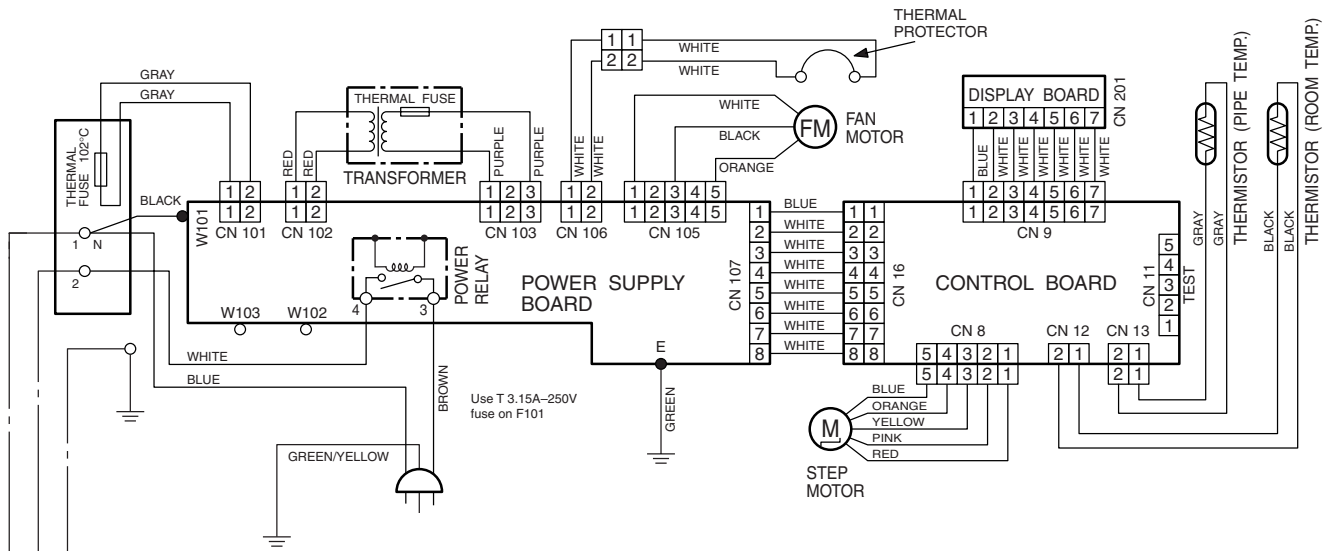

INDOOR UNIT  
OUTDOOR UNIT

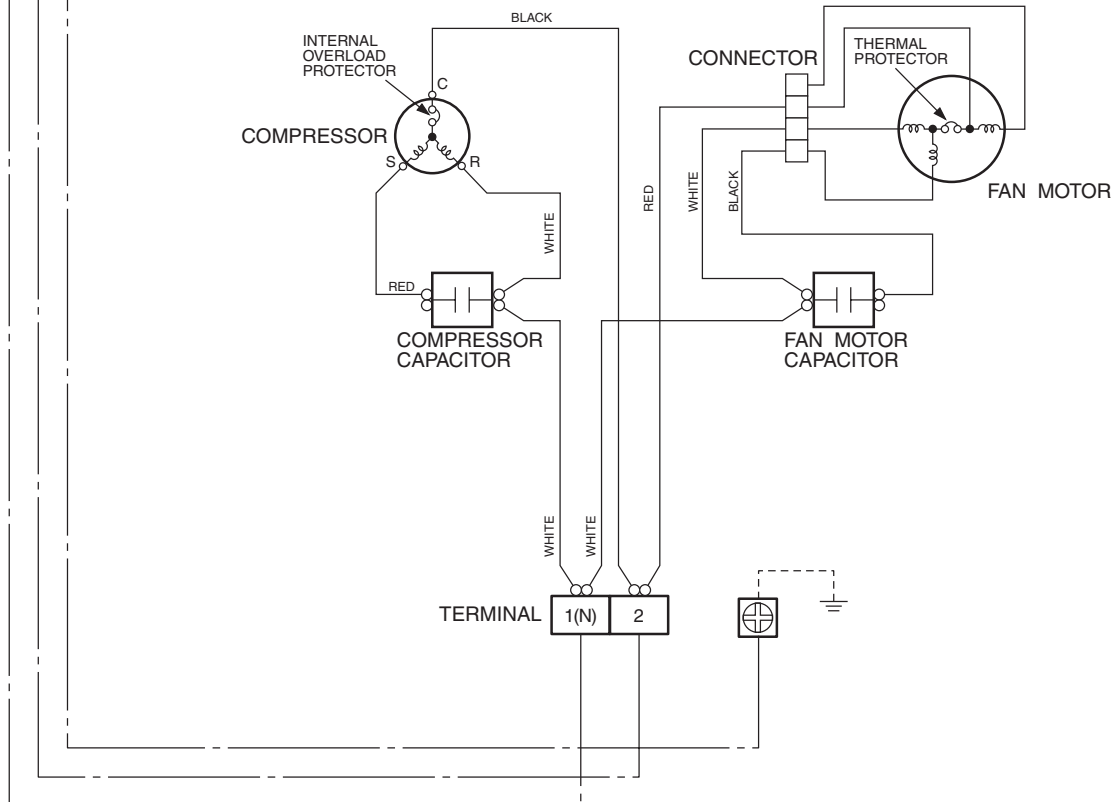

# INDOOR PRINTED CIRCUIT BOARD CIRCUIT DIAGRAM

Model : RS-17E

CONTROLLER PCB ASSEMBLY (MAIN PCB)  
EZ-099MWSE-C [GM-60108]

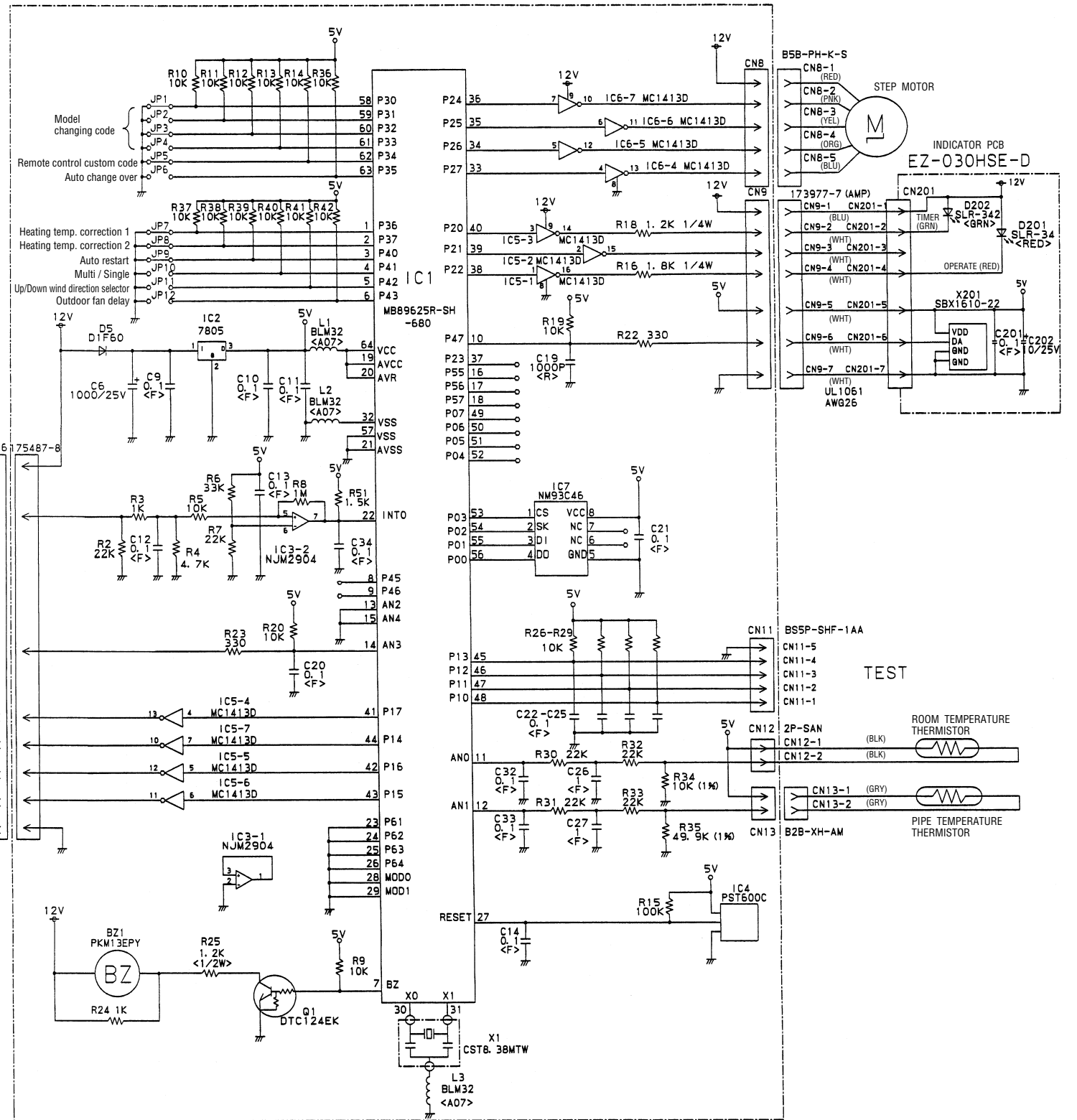
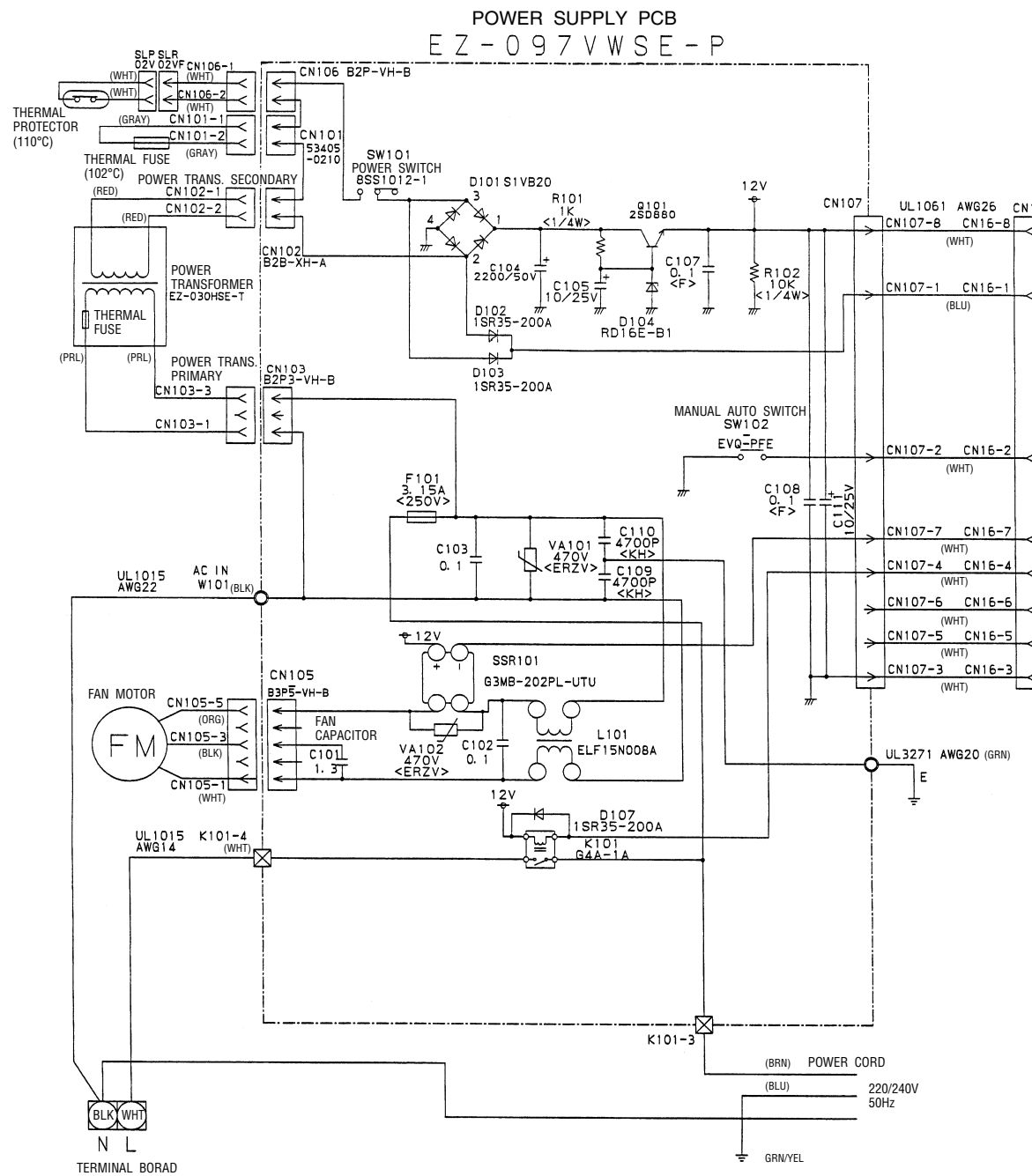

# INDOOR P.C. BOARD LAYOUTS

## CONTROLLER P.C. BOARD ASSEMBLY (MAIN PCB)

(Viewed from the solder side)

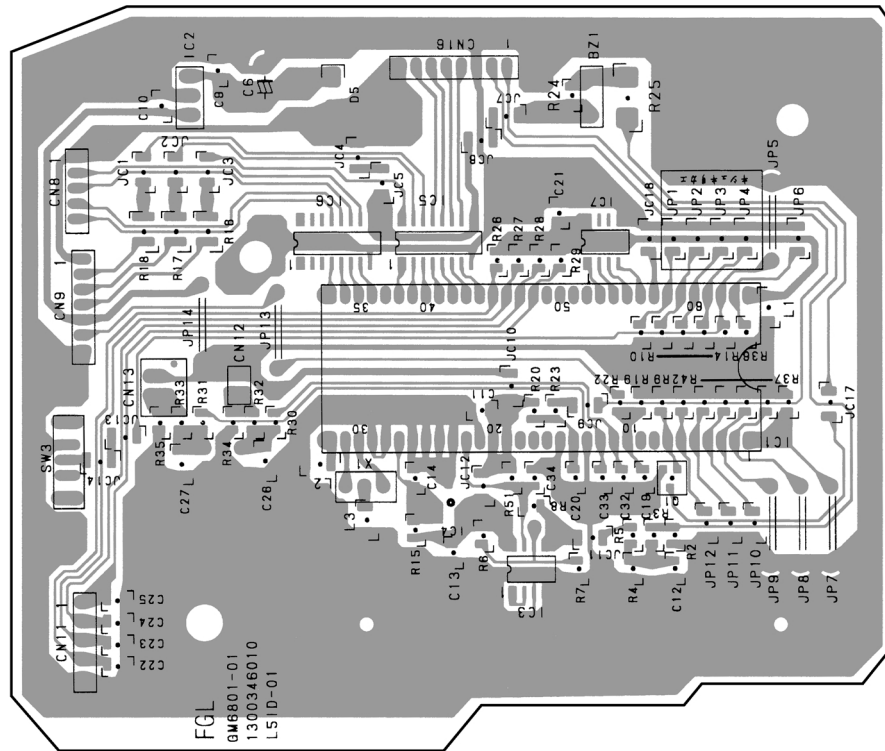

## POWER SUPPLY P.C. BOARD ASSEMBLY

(Viewed from the solder side)

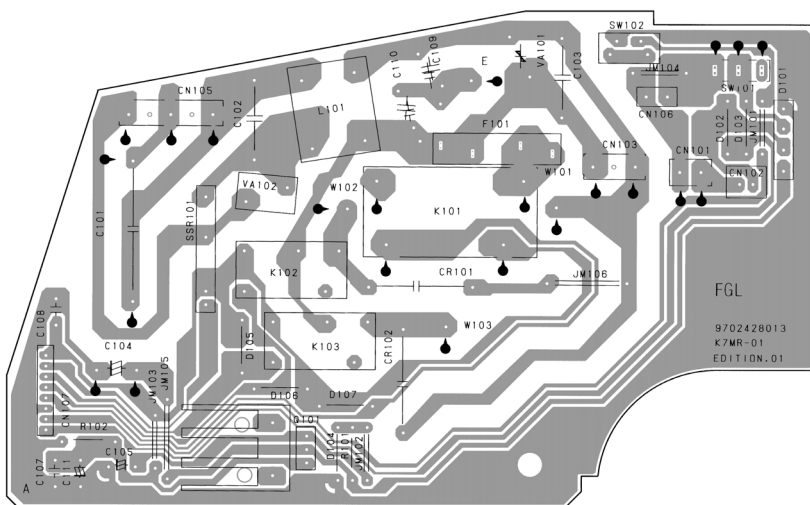

## INDICATOR P.C. BOARD ASSEMBLY

(Viewed from the solder side)

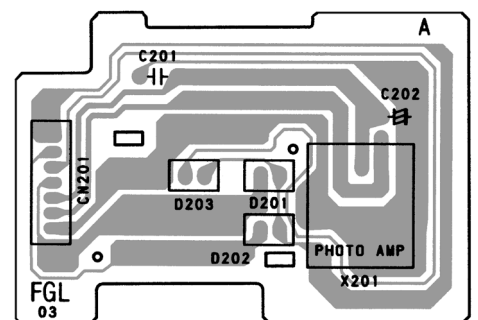

# REMOTE CONTROL UNIT CIRCUIT DIAGRAM

Model : RS-17E

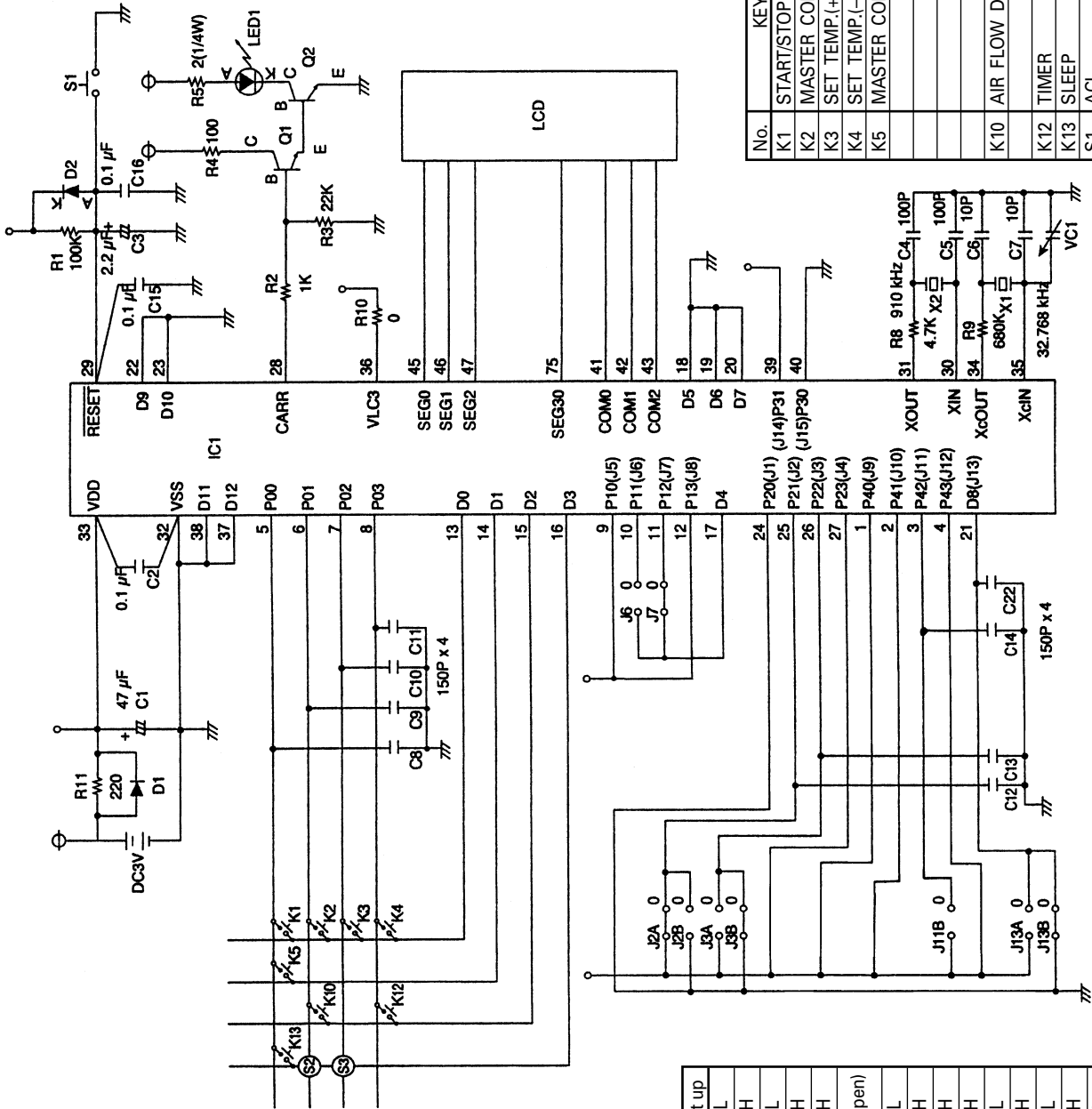

No.	KEYPADS
K1	START/STOP
K2	MASTER CONTROL
K3	SET TEMP.(+), SET TIME(+)
K4	SET TEMP.(-), SET TIME(-)
K5	MASTER CONTROL
K10	AIR FLOW DIRECTION
K12	TIMER
K13	SLEEP
S1	ACL
S2	TIME ADJUST
S3	TEST RUN

### Jumper Wire Function Selection

No.	Functions	Set up
J1	Change of timer button	L
J2	Transmitting code switching	H
J3	Heating mode	L
J4	Wind direction / auto louver	H
J5	Dry mode	H
J6	Temperature display of automatic operation	H(open)
J7	Fan / Circulator	L
J8	24H / 12H selector	H
J9	Temperature unit switching	H
J10	Fan mode	H
J11	Quiet	L
J12	Sleep	H
J13	Display change of automatic operation	L
J14	Remote controller selector I	H
J14	Remote controller selector II	L

L : Connected to 777

H : Connected to Q

# DISASSEMBLY ILLUSTRATION

Model : RS-17E

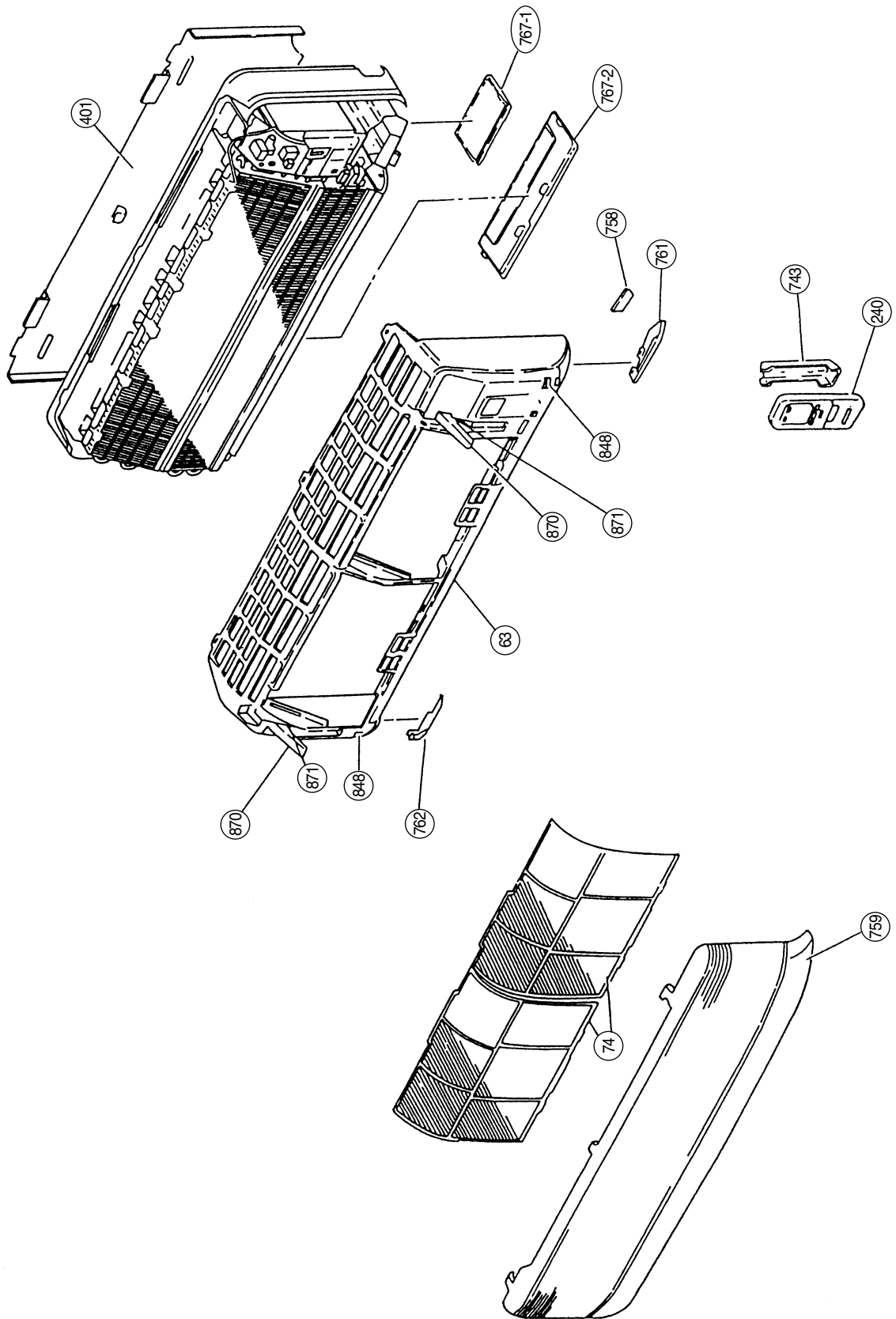





Model : RO-17E

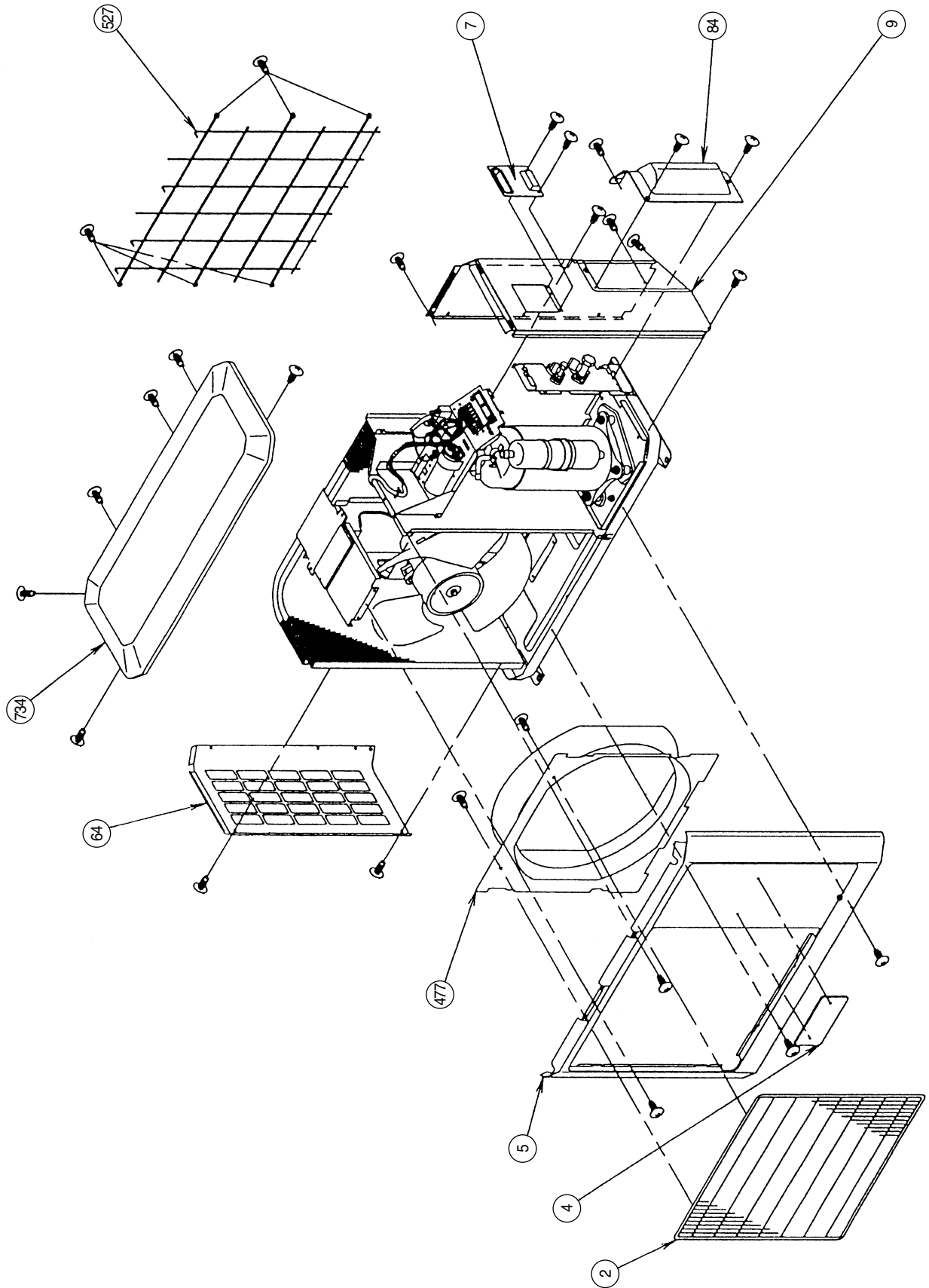

**Model : RO-17E**

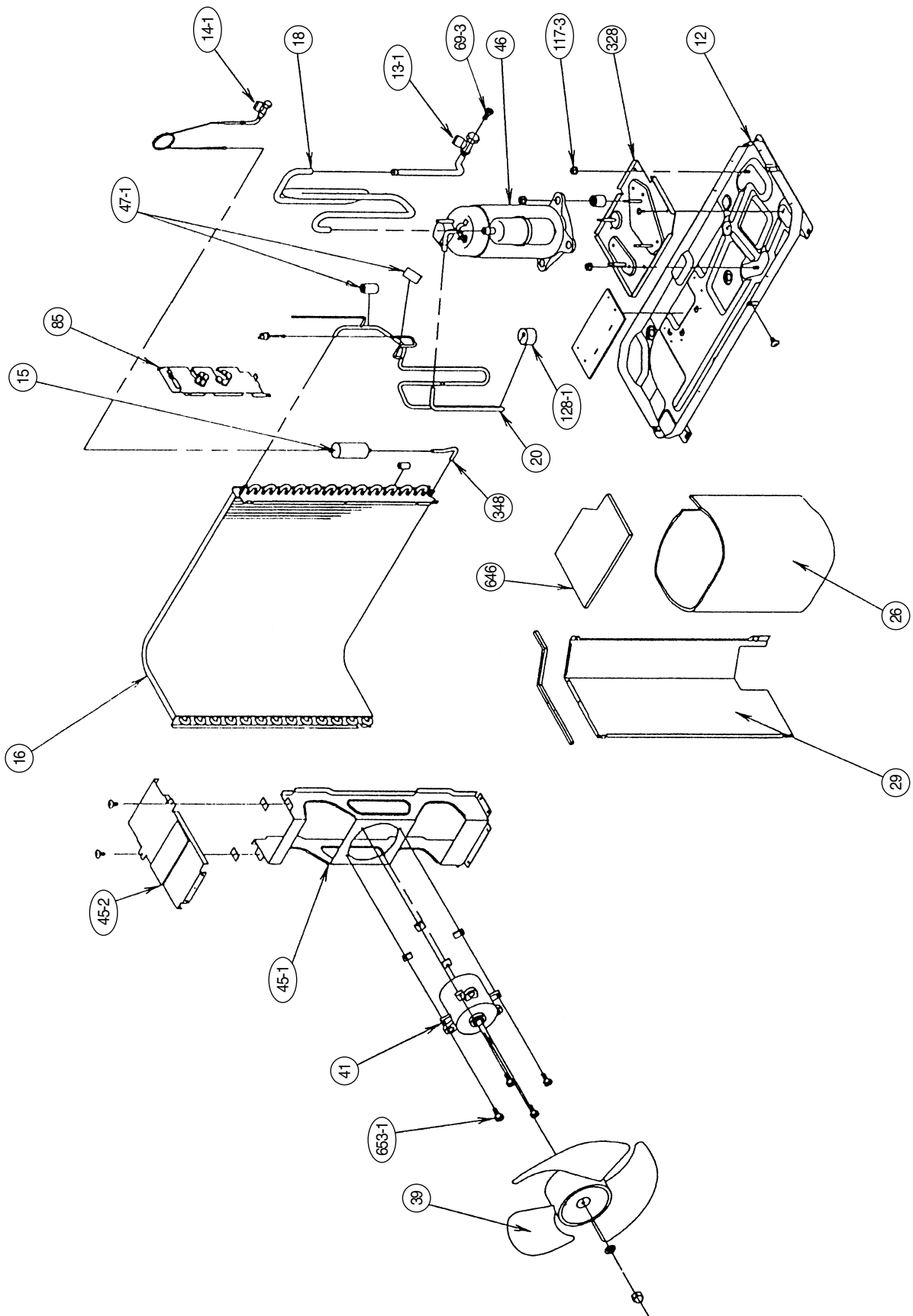

**Model : RO-17E**

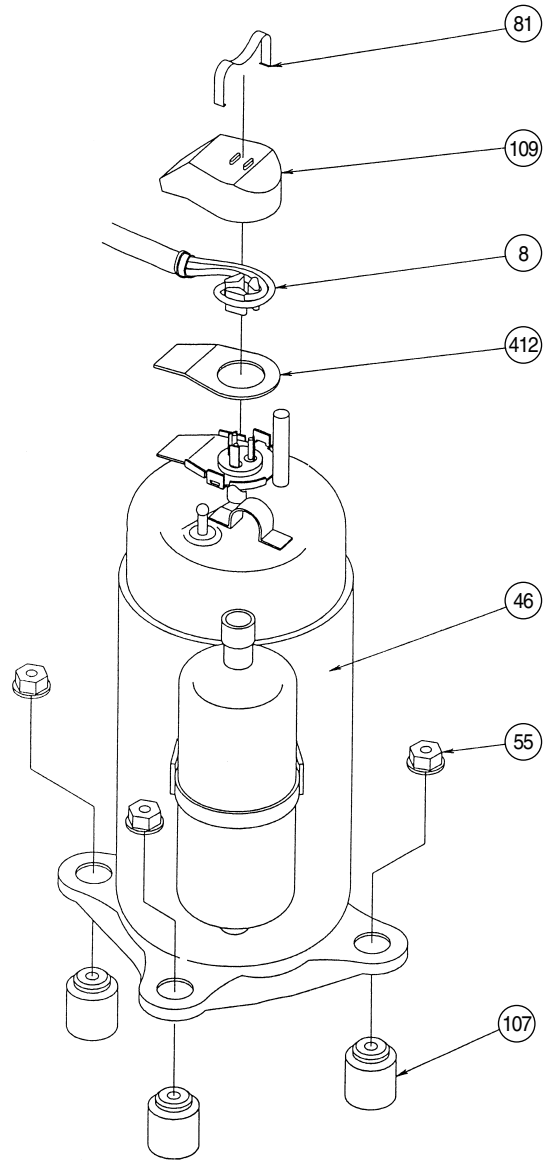

**Model : RO-17E**

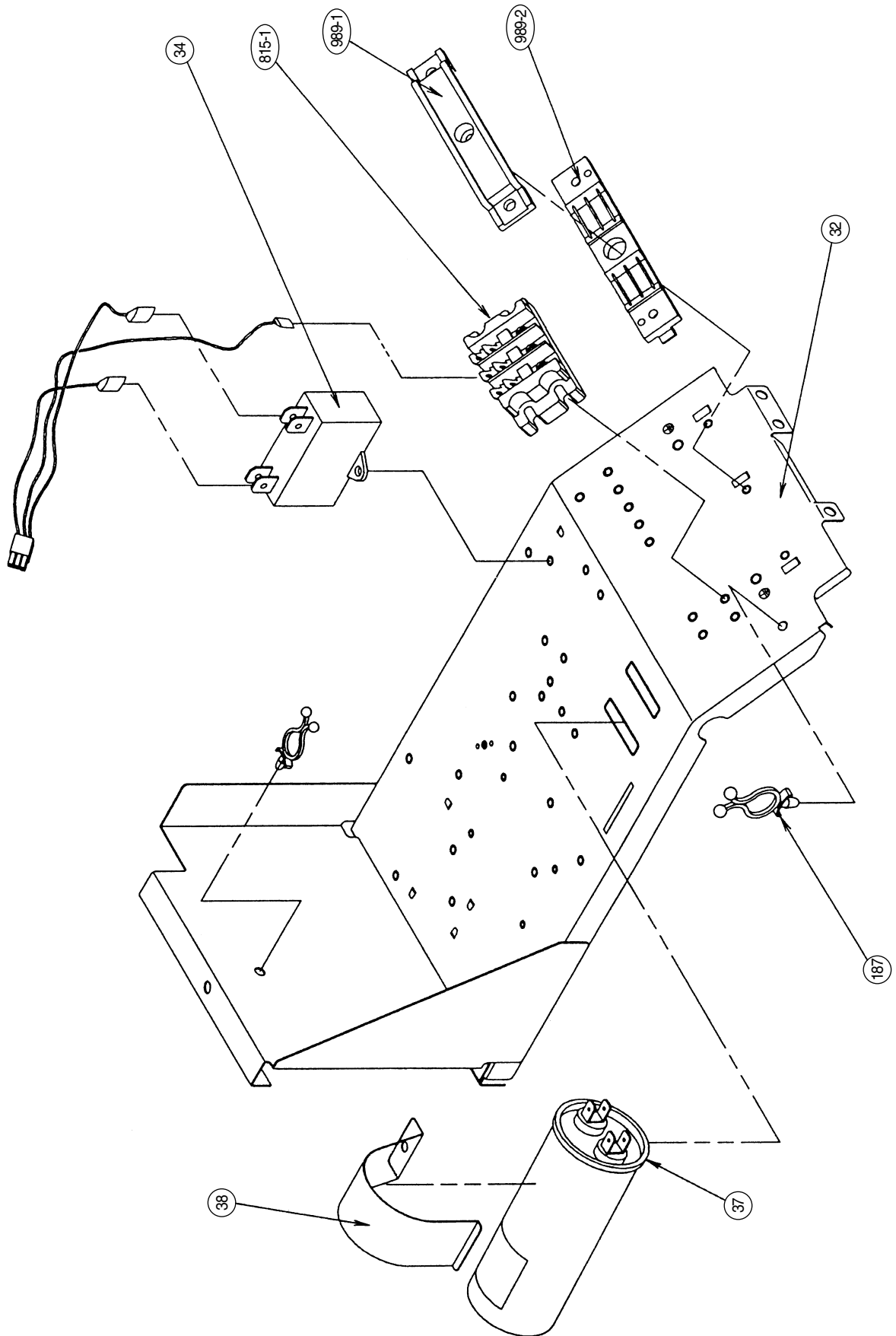

# PARTS LIST

When you order parts, please make a photocopy of this page and fill the number of the parts in the "Order" column.

## INDOOR UNIT

Ref. No.	Description	Part No.	Ord. Q'ty	Ref. No.	Description	Part No.	Ord. Q'ty
		RS-17E				RS-17E	
28	Blower Cover	9304111016		406	Louver-L Assy	9354644014	
63	Front Panel Assy	9354229235		407	Louver-R Assy	9354643017	
65	Flow Control Panel	9354646063		425	Earth Terminal	9357852003	
74	Filter	9304097013		652-1	Thermistor Holder Pipe	313714262805	
108	Base	9304107033		736	Operation Panel	9354230002	
109	Casing	9304108016		743	Remote Control Unit Holder Case	9305642014	
122	Shaft Holder-B Assy	9304470007		758	Decoration Plate-A	9354223011	
127	Drain Hose Assy	9304761013		759	Intake Grille-A "FUJI"	9355595063	
146	Evaporator Assy	9363335002		761	Side Cover-R	9303518076	
151	Control Box	9304092001		762	Side Cover-L	9303520147	
158	Connecting Pipe Assy	9363632002		764	Drain Cap Assy	9304150008	
164	Fan Motor Assy-In	9354513044		767-1	Bottom Cover-A	9303536056	
169	Cross-flow Fan Assy	9306327002		767-2	Bottom Cover-B	9303537053	
178	Motor Cushion-G	9304669005		780	Key Top (Slide Switch)	9303526002	
184-1	Thermostat Spring-A	313728262708		815	Terminal-2P	9701955022	
185	Wire Clamp	9356959000		848	Catcher	9306545000	
188	Power Cord Assy	9359917007		870	Arm	9303525005	
233	Power Transformer	9701803026		871	Arm Spring	9304377009	
235	Thermistor Assy-Pipe	9702325015		872	Indicator Case	9303631003	
236	Controller PCB Assy	9702529031		874	Control Box Cover	9304094005	
240	Remote Control Unit AR-AB25	9356765076		875	Power Supply PCB Assy	9702451028	
251	Hose Clamp	9304077008		876	Step Motor	9304535003	
268	Motor Cover-B	9304231004		963	Fan Guard	9356881011	
281	Clamp Metal (Pipe)	9304242000		977	Louver Clip, Plastic	9356880014	
283	Bushing-A	9303529010		978	Wire Bracket-L	9356878011	
345	Filter Guide	9304110019		979	Wire Bracket-R	9356877014	
385	Indicator PCB Assy	9701119011		983	Therm. Protect Cover	9356882001	
401	Wall Hook Bracket	9304093008					

## OUTDOOR UNIT

Ref. No.	Description	Part No.	Ord. Q'ty	Ref. No.	Description	Part No.	Ord. Q'ty
		RO-17E				RO-17E	
2	Fan Cover (Guard)	9359808015		64	Cabinet-Left, Painted	9359840046	
4	Emblem-Rear "FUJI"	9361328006		69-3	Bolt, Hex. Socket	301210060360	
5	Cabinet-A, Painted	9359797043		81	Strap (For Comp.)	9362371001	
7	Connector Cover (Panel, Top)	9358011010		84	Valve Cover	9361325012	
8	Wire Assy(Shield)-D	9359904052		85	Valve Fixing Plate	9361324015	
9	Cabinet-B, Painted	9361323025		107	Rubber Mount (For Comp.)	9362368001	
12	Base Assy, Painted	9359813019		109	Terminal Cover (For Comp.)	9362369008	
13-1	3-Way Valve(1/2), (R407C)	9363245004		117-3	Hexagon Nut (Spring Lock Washer)	301721180114	
14-1	2-Way Valve(1/4), (R407C)	9363247008					
15	Dryer	9362498005		128-1	Rubber (Discharge Pipe) (Counter Weight)	313155086308	
16	Condenser Assy	9362546003		187	Clamp No. 1219	313361271706	
18	Suction Pipe Assy	9362541008		328	Compressor Plate Assy	9362273022	
20	Discharge Pipe Assy	9363331004		348	Outlet Pipe	9362547000	
26	Compressor Cover-A	9362535007		412	Terminal Gasket (For Comp.)	9362370004	
29	Separate Wall	9359805014		477	Bell Mouth	9359809012	
32	Control Box Metal-A	9361409019		527	Protection Net (Condenser Net)	9359845010	
34	Capacitor (Fan Motor)	9357965024					
37	Running Capacitor	9703107108					
38	Capacitor Clamp Metal	9351770013					
39	Propeller Fan	9359837015		646	Compressor Cover-B	9362876001	
41	Fan Motor Assy-Out	9600266045		653-1	Bolt (Fan Motor Fixing)	0700156014	
45-1	Motor Bracket	9359802013		734	Cabinet Top Plate, Painted	9359799023	
45-2	Motor Bracket-Top	9359803010		815-1	Terminal-3P	9356488005	
46	Compressor Assy	9362574006		989-1	Cord Clamp-A	9359822011	
47-1	Rubber(Discha. Pipe)	313194159807		989-2	Cord Clamp-B	9359823018	
55	Special Nut M8 (For Comp.)	9355091008					

When you order parts, please make a photocopy of this page and fill the number of the parts in the "Order" column.

### CONTROLLER PCB ASSEMBLY (Ref. No. 236)

Ref. No.	Description	Part No.	Ord. Q'ty	Ref. No.	Description	Part No.	Ord. Q'ty
IC1	IC MB89625R-SH-686	1301815010		R34	Res. 10kΩ±0.5%	0200344010	
IC2	IC NJM7805FA	0100462081		R35	Res. 49.9kΩ±0.5%	0200344683	
IC3	IC NJM2904M	0100534054		R51	Res. 1.5kΩ±5%	0200212784	
IC4	IC PST600CMTR	0101461120		JP1,3,JC1-7,9-12,17,18	Res. 0Ω	0200230016	
IC5,6	IC MC1413DR2	0101736013		C6	Cap. Elec. 25V 1000μF	0300631256	
IC7	IC NM93C46M8-X	0101622026		C9-14,20-25,32-34	Cap. Ceramic 0.1μF	1902783046	
Q1	Xstr DTC124EK	0000517034		C19	Cap. Ceramic 1000pF	1902829072	
D5	Diode D1F60	0000208024		C26,27	Cap. Ceramic 1μF	1800119015	
R2,7,30-33	Res. 22kΩ±5%	0200213095		X1	Ceramic Resonator CST 8.38MTW-TF01	1300116019	
R3, 24	Res. 1kΩ±5%	0200212746		BZ1	Buzzer PKM13EPY-4000-TF01	9701298013	
R4	Res. 4.7kΩ±5%	0200212906		L1-3	EMI Filter BLM31A601SPT	0400119029	
R5,9-14,19,20,26-29,36-42	Res. 10kΩ±5%	0200213019		JP5,7-9,13,14	Wire IPS-3002-4	1903332014	
R6	Res. 33kΩ±5%	0200213132		CN8	Plug, PCB B5B-PH-K-S	0500200061	
R8	Res. 1MΩ±5%	0200213491		CN9	Plug, PCB 175487-7	0500891016	
R15	Res. 100kΩ±5%	0200213255		CN11	Plug, PCB BS5P-SHF-1AA	0500898015	
R16	Res. 1.8kΩ±5%	0200691725		CN12	Thermistor (Room Temp.)	9700801023	
R17,18	Res. 1.2kΩ±5%	0200691534		CN13	Plug, PCB B2B-XH-A	0500005055	
R22,23	Res. 330Ω±5%	0200212623		CN16	Plug, PCB 175487-8	0500891023	
R25	Res. 1.2kΩ±5%	0201001769					

### POWER SUPPLY PCB ASSEMBLY (Ref. No. 875)









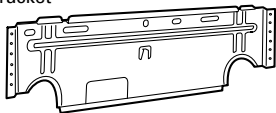
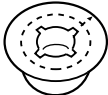

Ref. No.	Description	Part No.	Ord. Q'ty	Ref. No.	Description	Part No.	Ord. Q'ty
Q101	Xstr 2SD880	0000001014		L101	EMI Filter ELF15N008A	0400165071	
D101	Diode S1VB20	0000292054		SW101	Slide Switch 8SS1012-1	9701426010	
D102,103,107	Diode 1SR35-200A	0000016018		SW102	Push Switch EVQPF04R	9700891017	
D104	Diode RD16EB1	0000296014		F101	Fuse BET 3.15A - 250V	0600222512	
R101	Res. Carbon 1/4W 1kΩ±5%	0201038758			Fuse Holder SN-5057	9700116011	
R102	Res. Carbon 1/4W 10kΩ±5%	0201005019		CN101	Plug, PCB 53405-0210	0500940011	
C101	Cap. Plastic 400V 1.3μF	0300939048		CN102	Plug, PCB B2B-XH-A	0500005055	
C102,103	Cap. Plastic 0.1μF	0300304075		CN103	Plug, PCB B2P3-VH-B	0500011728	
C104	Cap. Elec. 50V 2200μF	0301190981		CN105	Plug, PCB B3P5-VH-B	0500011735	
C105,111	Cap. Elec. 25V 10μF	0300007341		CN106	Plug, PCB B2P-VH-B	0500011124	
C107,108	Cap. Ceramic 0.1μF	0300988251		CN107	Wire w/Connector L=180	9701052011	
C109,110	Cap. Ceramic 4700pF	0300209110		JM101-103	Wire 0.6mm dia. L=10mm	9700025016	
VA101	Varistor ERZ-V10V471CS	0000515139		JM105	Wire 0.6mm dia. L=15mm	9700672012	
VA102	Arrester CP2470-F	9701835010		W101	Wire w/Terminal L=190 BLK	9701169191	
SSR101	Relay G3M-202PL-UTU	9701375011		E	Wire w/Terminal L=250 GRN	9701150014	
K101	Relay G4A-1A-PS	9701024018					

### INDICATOR PCB ASSEMBLY (Ref. No. 385)

Ref. No.	Description	Part No.	Ord. Q'ty	Ref. No.	Description	Part No.	Ord. Q'ty
X201	Remote control Amplifier SBX1810-22	0101525129		CN201	Wire w/Connector L=250	9700923015	
D201	Diode SLR-34LR RED	0000727013			Lamp Cover-A	9303702000	
D202	Diode SLR-342MG GRN	0000727167		C201	Cap. Ceramic 0.1μF	0300988251	
				C202	Cap. Elec. 25V 10μF	0300328026	

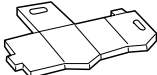
# STANDARD ACCESSORIES

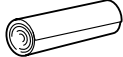
## INDOOR UNIT ACCESSORIES

Name and Shape	Part No.
Wall hook bracket 	9304093008
Wall cap 	313714296205
Remote control unit 	9356765076 (AR-AB25)
Battery (penlight) 	0600185534
Tapping screw (big) (ø4 x 20) 	301141164200
Tapping screw (small) (ø3 x 12) 	301141533125
Flange screw (ø4 x 10) 	9305114009
Spacer 	No part No. This is a part of cardbord accessories (9304297000).
Remote control unit holder case 	9305642014
Cloth tape 	9304232001
Seal-A 	9304536000

## OUTDOOR UNIT ACCESSORIES

Name and Shape	Part No.
Hexagon wrench 	9351228019





MANUFACTURER :

**Fuji Denki Sosetsu Co., Ltd.**

Tokyo, Japan