

VR 20/25

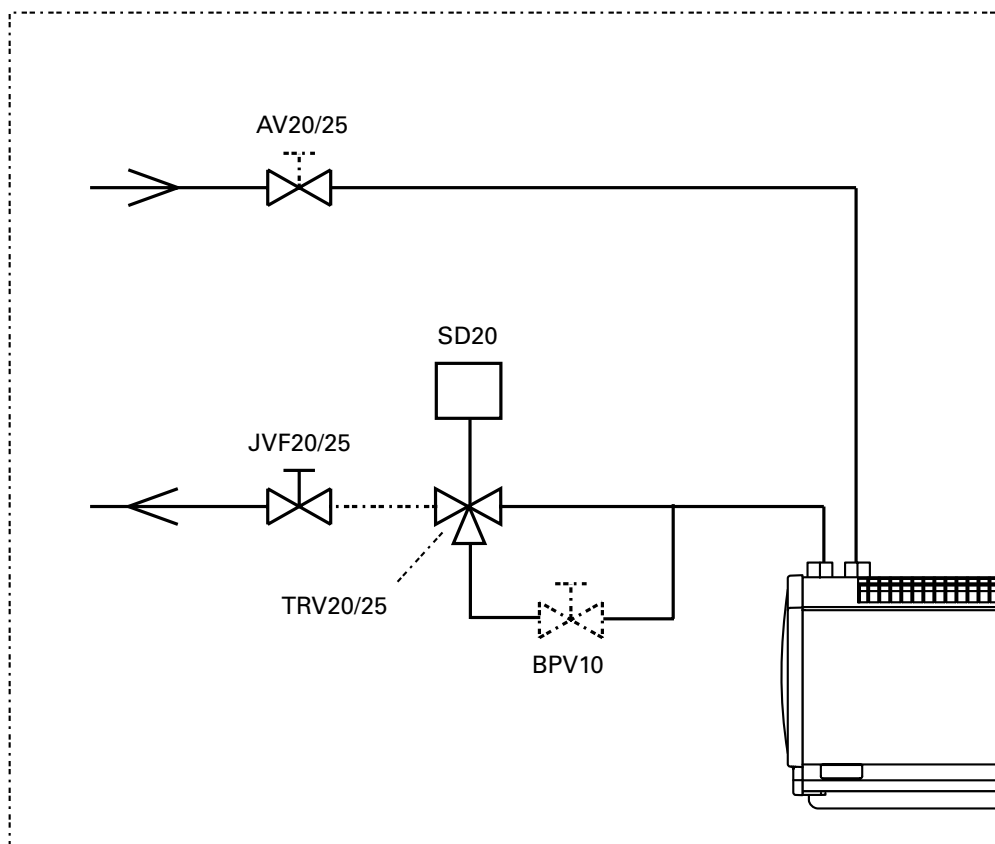

VR 20/25

For regulating the waterflow in water-heated units.

The VR20/25 contains the following parts:

1. AV20/25, off regulator valve
2. JVF20/25, balancing valve
3. TRV20/25, 3-way valve
4. SD20, actuator on/off 230 V~ ("soft closing")
5. BPV10, bypass valve

The off regulator (AV20/25) is either set to be closed or open and it's therefore used when no waterflow is wanted, for example during maintenance. With the balancing valve the waterflow can be manually adjusted or be closed completely. NB! Completely closed balancing valve is not 100 % secure of water leakage. The adjusted waterflow can be read directly on the valve without any other instruments. If the 3-way valve is closed, the waterflow will pass by through the bypass valve (BPV10). The bypass valve is used for a certain frost protection or when hot water should always exist in the waterbattery at all times, for example in case of a door opens and a quick heat supply is needed. The actuator (SD20) regulates the water supply on/off and it's "soft closing" just to avoid noise and pressure blow in the pipe system.

The set of valves has two different dimensions. The VR20 has DN20 (3/4") which has the total Cv-value of 3,01 and the VR25 has DN25 (1") has the total Cv-value of 4,70. The bypass valve has a DN10 (3/8"). For regulating the VR20/25 complement with an appropriate thermostat.



AV20/25

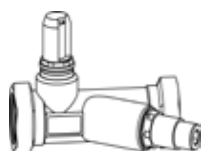

JVF20/25

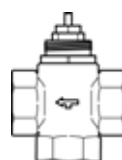

TRV20/25

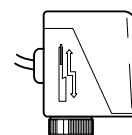

SD20



BPV10

Technical specifications | VR20/25

Type	Article no.	RSK no.	Description	HxWxD [mm]
VR20/25	10089 / 10091	672 59 98 / 672 59 99	Waterflow regulator	-
AV20/25	10017 / 10020	672 75 94 / 672 75 95	Off regulator water valve	70x130x32 / 85x140x42
JVF20/25	16788 / 16789	672 75 96 / 672 75 97	Balancing valve	86x37x68 / 120x69x73
TRV20/25	10005 / 10002	672 75 98 / 672 75 99	3-way valve	66x66x40 / 90x74x45
SD20	10073	672 70 37	Actuator on/off ("soft closing")	75x75x65
BPV10	10030	672 76 00	Bypass valve	63x45x28

Off regulator valve (AV20/25)

(104507107 / 104510107)

Application

The off regulator valve is used to turn off the water supply to the unit. It's either open or closed and has no balancing functions. It's therefore usually used for maintenance and service purposes.

Technical specifications | AV20/25

Type	Article no.	RSK no.	Weight [kg]
AV20	10017	672 75 94	0,3
AV25	10020	672 75 95	0,3

Dimensions [mm]

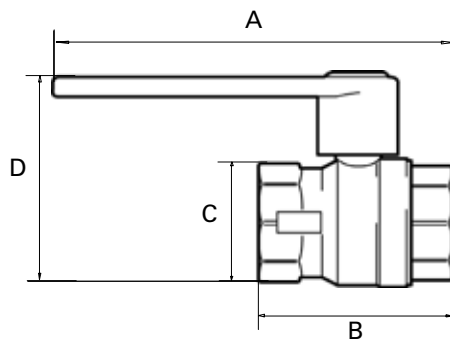

Type	A	B	C	D
AV20	130	57	32	70
AV25	140	62	42	85

Balancing valve (JVF20/25)

(D3498295 / D3498355)

Application

The balancing valve is intended for balancing heat or cooling systems. It's used to adjust a certain waterflow/pressure over the pipe system and can also be used as an off regulator. NB! Completely closed balancing valve is not 100 % secure from water leakages.

JVF balancing valve is provided with an integrated waterflow instrument, that continuously measures the actual waterflow. By using the adjustment screw, the waterflow can easily be adjusted and measured without any other measure instruments. It's possible to read the actual waterflow even when the valve is isolated. The actual waterflow can easily be read from any angle though the measuring scale can be rotated.

The fluid doesn't pass by the integrated measure instrument which eliminates the risk for any contamination; continuously reading can therefore take place long time after the installation. There is also a socket for measuring pressure with an external instrument.

JVF balancing valve has an unchanged waterflow profile inside. It's therefore sufficient with a straight piece of tube before the inlet that has the same diameter and length as the valve itself.

Specifications | JVF20/25

Type	DN	Flowing area [l/min] ¹⁾	Cv [m ³ /h]	Pressure drop diagram
JVF20	20	4 - 36	3,5	2
JVF25	25	5 - 50	7,0	3

1) Applies for water and glycol additives with a temp. from +20 °C up to max. operating temperature.

Max. operating temperature :	see Pressure/temperature diagram
Min. operating temperature :	- 20 °C (Using appropriate antifreeze compounds)
Max. operating pressure :	see Pressure drop diagram
Waterflow accuracy :	± 10 % on actual reading

Pressure drop diagram

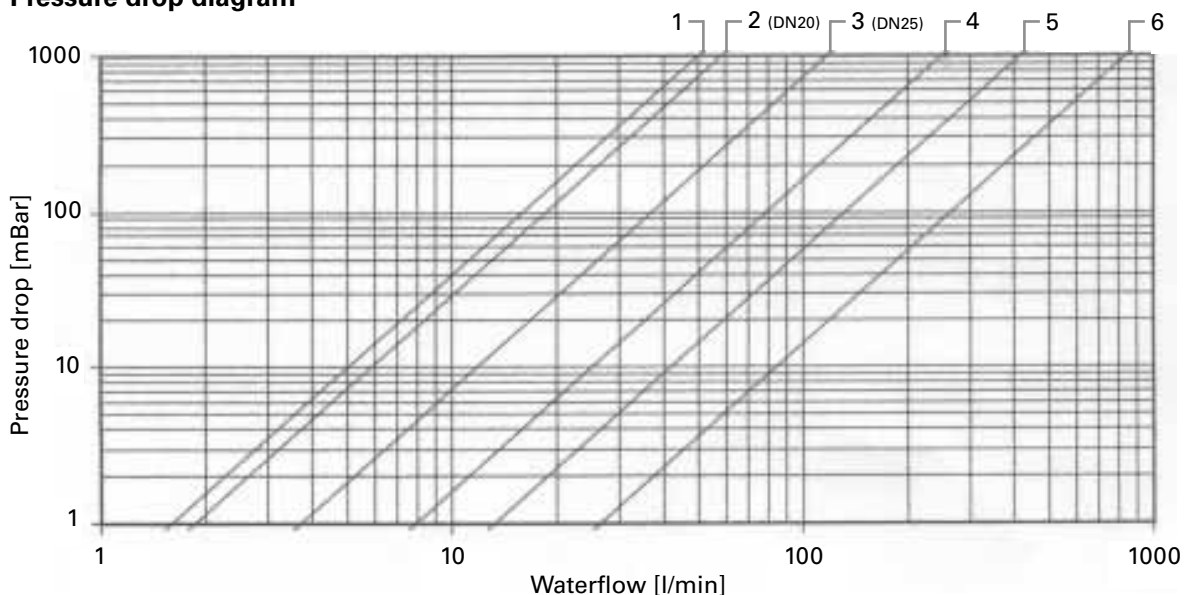

Pressure/temperature diagram

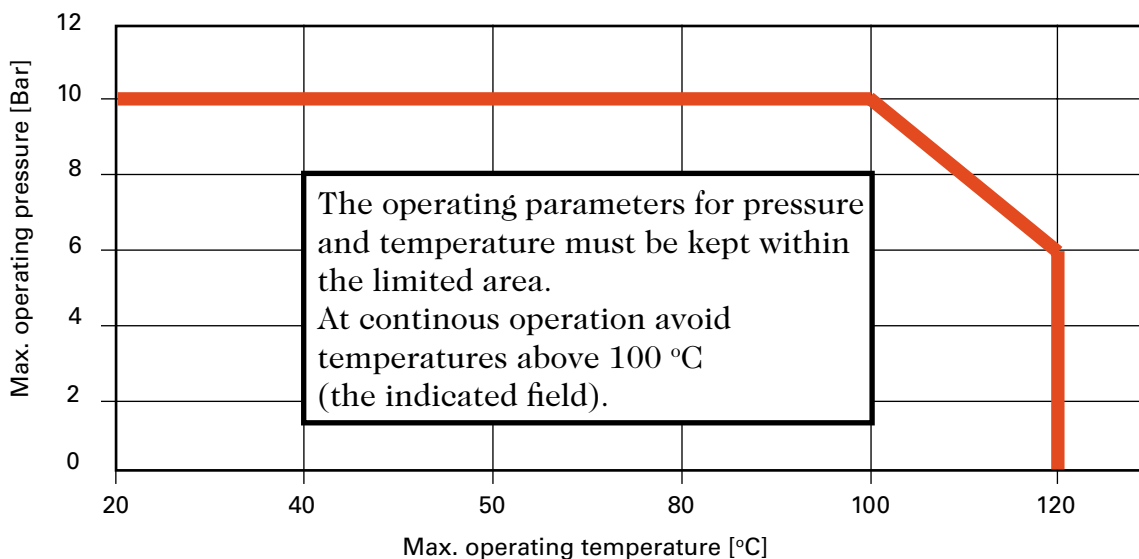

Technical specifications | JVF20/25

Type	DN	Connection	Article no.	RSK no.	HxWxD [mm]	Weight [kg]
JVF20	20	15/22 mm compression fitting	16788	672 75 96	86x37x68	-
JVF25	25	Internally G25	16789	672 75 97	120x69x73	-

Material

Housing and interior :	Brass
Flowmeter :	High quality plastics - impact resisting and temperature stable
Spring :	Stainless steel
Gaskets :	EPDM elastomers

Dimensions [mm]

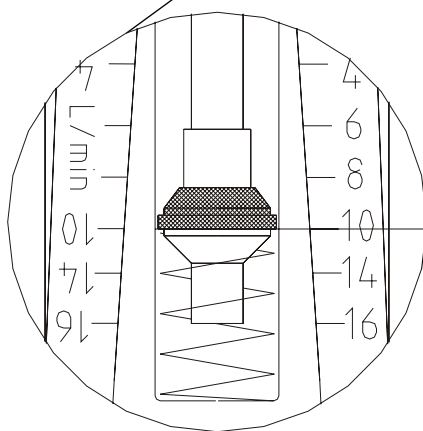
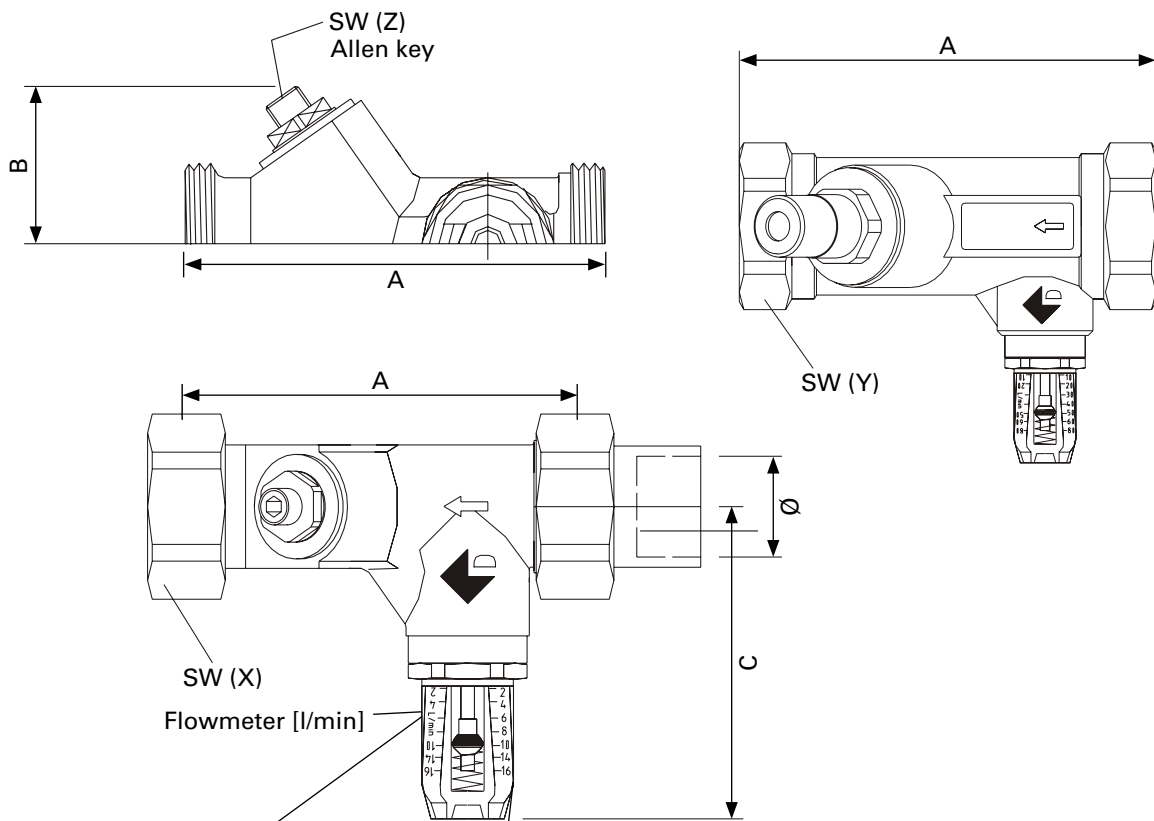

Connection	A	B	C	SW(X)	SW(Y)	SW(Z)
15/22 mm compression fitting	86	37	68	37	-	4
Internally G25	120	69	73	46	42,5	6

Example: Waterflow 10 l/min

3-way valve (TRV20/25)

(VG5800KC / VG5800MC)

Application

TRV20/25 (3-way valves) are primarily designed to regulate the flow of water in response to demand of a controller. These valves are made in forged brass and stainless steel stem which ensures a long life.

The valves should be used in combination with an electric on/off actuator. The actuator can be mounted after piping, this simplifies installation in confined locations. The valves have even a built in return spring which allows the valves to return to normal position when the actuator is de-energized.

Choice of valve

The right dimension of the valve can be decided from the diagram below. Keep in mind that the pressure drop and the flow of water must be kept within the white indicated field.

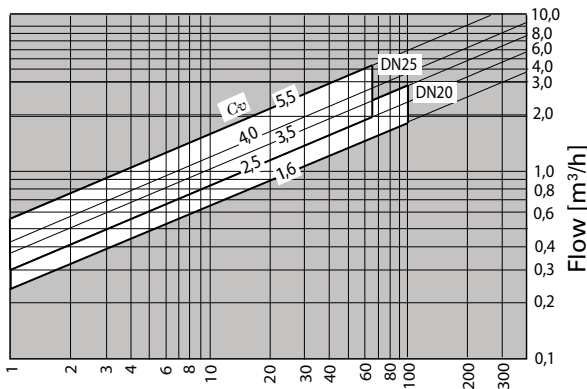

Pressure drop p, [kPa] (1 kPa = 10 mBar = 100 mmWK)

Operating

When power is applied the actuator pushes the valve stem down against the return spring which allows the waterflow to pass by. When de-energized the return spring will return the valve to it's normal position, a closed valve.

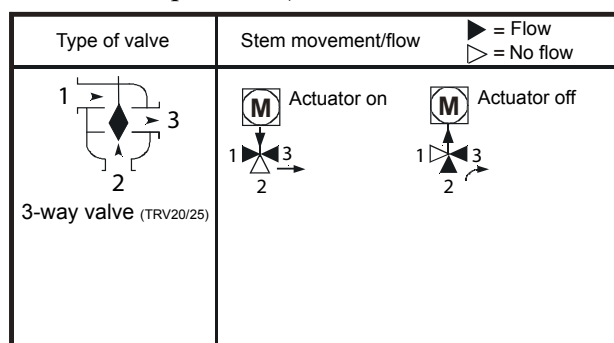

Mounting

The valve must be mounted in the direction of the arrow according to the direction of the flow of water that pass by the valve. Valve with an actuator must be mounted within 90 degrees of the upright position, free from dripping water and easy accessible for the electrical wiring.

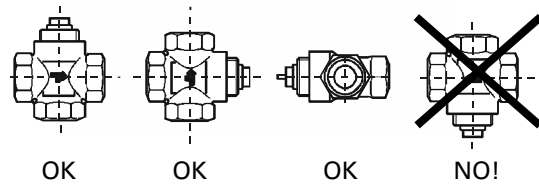

Technical specifications | TRV20/25

Type	Article no.	RSK no.	HxWxD [mm]
TRV20	10005	672 75 98	66x66x40
TRV25	10002	672 75 99	90x74x45

Specifications	TRV20/25	
Connection :	DN20 (3/4")	DN25 (1")
Cv-värde (set for TRV) :	3.5	5.5
Max. pressure drop :	100 kPa	62 kPa
Fluid temperature limits :	+ 2 °C to + 95 °C	
Ambient temperature limits :	Min. : 2 °C	Max. : 50 °C
Stroke :	3 mm	
Weight [kg] :	0,48	0,8

Material

Valve :	Brass
Packing nut :	Brass
Cage :	Brass
Stem :	ANSI Stainless steel
Spring :	Stainless steel
Plug :	Rubber EPT
Packing :	Two rubber EPT O-rings

Actuator on/off (SD20)

(VA-7010-8103A)

Application

The electrical actuator in combination with the 3-way valve (TRV20/25) is used for regulating the heat supply to the unit. Its function is to open or close the valve (on/off). The actuator will open the valve when power is applied. The actuator is "soft closing" just to avoid noise and pressure blow in the pipe system.

The electrical actuator can be mounted and rotated after that the valve has been installed.

For regulating the actuator in combination with valve complement with appropriate thermostat.

Mounting

Never use the actuator as a mounting lever. Make sure the actuator is free of thermal insulation connections and leave at least 20 mm clearance above the actuator for mounting purposes according to the figure below.

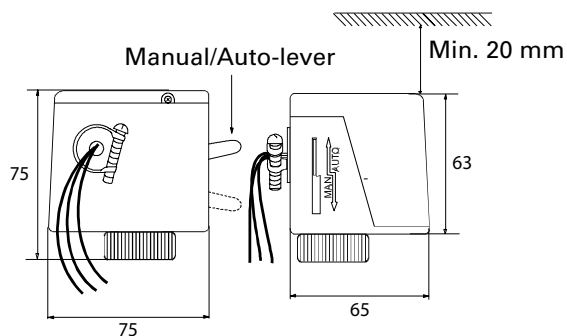

Technical specifications | SD20

Type	Article no.	RSK no.	HxWxD [mm]	Weight [kg]
SD20	10073	672 70 37	75x75x65	0,5
Action :	On/Off			
Supply Voltage :	230 V~ -10 % / +15 %			
Power consumption :	7 VA			
Min. force (nominal) :	150 N -10 % / +20 %			
Stroke (nominal) :	3 mm (max. 5 mm)			
Full stroke time "On" :	Nominal 10 sec.			
Full stroke time "Off" :	Nominal 5 sec.			
Enclosure :	IP40, NEMA 1			
Ambient operating condition :	+2 °C to +50 °C			
Ambient storage condition :	-20 °C to +65 °C			
CE Conformity :	EMC Directive 89/336 EU			

Bypass valve (BPV10)

(193SN38R)

Application

The bypass valve is used when a small amount flow of water should pass by the unit at all times. The purpose of this is that the water should always stay hot in the watercoil, in cases when a door opens and a quick heat supply is needed.

This kind of valve has the dimension DN10 (3/8").

When mounting the plug inside the valve must be screwed entirely at first and then screwed back a whole lap. In cases where the distance between inlet and the unit is far away, open the plug even more by screwing the plug backwards.

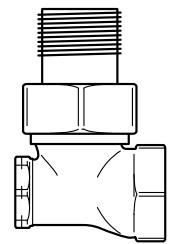

Technical specifications | BPV10

Type	Article no.	RSK no.	HxWxD [mm]	Weight [kg]
BPV10	10030	672 76 00	63x45x28	0,17