

**ESBE**

www.esbe.se

**SERIES CTF150****ESBE**

NO.1 IN HYDRONIC SYSTEM CONTROL



Series CTF151

CE

LVD 2006/95/EC
EMC 2004/108/EC
RoHS 2002/95/EEC

CTF151



CTF851

**GB** **INSTALLATION**

All work must be performed by qualified personnel and in accordance with applicable codes and ordinances.

SE **INSTALLATION**

Allt arbete skall utföras av kvalificerad personal och i överensstämmelse med gällande lagar och bestämmelser.

DE **EINBAU**

Alle Arbeiten müssen von qualifiziertem Personal und in Übereinstimmung mit den geltenden Gesetzen und Verordnungen ausgeführt werden.

FR **INSTALLATION**

Tous les travaux doivent être réalisés par un personnel qualifié et conformément aux codes et règlements en vigueur.

IT **INSTALLAZIONE**

Tutti i lavori devono essere effettuati da personale qualificato nel rispetto delle leggi e delle normative vigenti.

BG **МОНТАЖ**

Всички работи трябва да бъдат изпълнени от квалифициран персонал съгласно приложените правила и наредби.

CS **INSTALACE**

Všechny práce musí provádět kvalifikovaný personál v souladu s platnými zákony a předpisy.

DK **INSTALLATION**

Alt arbejde skal udføres af kvalificeret personale og i overensstemmelse med gældende lovgivning og bestemmelser.

EL **ΕΓΚΑΤΑΣΤΑΣΗ**

Όλες οι εργασίες πρέπει να πραγματοποιηθούν από καταρτισμένο προσωπικό σύμφωνα με τους ισχύοντες κώδικες και διατάξεις.

ES **INSTALACIÓN**

Todos los trabajos deben ser realizados por personal cualificado y de conformidad con la normativa y legislación aplicables.

ET **PAIGALDAMINE**

Töö peab teostama kvalifitseeritud töötaja ning vastavalt kohaldatavatele eeskirjadele ja määrustele.

FI **ASENNUS**

Pätevän henkilöstön on suoritettava kaikki työt sovellettavien sääntöjen mukaisesti.

HR **POSTAVLJANJE**

Rad mora izvesti kvalificirano osoblje i u skladu s primijenjenim pravilima i propisima.

HU **BESZERELÉS**

A munkát kizárólag szakképzett személyzet végezheti, a vonatkozó előírásoknak és rendeleteknek megfelelően.

LT **MONTAVIMAS**

Visus darbus turi atlikti kvalifikuoti darbuotojai pagal galiojančias taisykles ir potvarkius.

LV **UZSTĀDĪŠANA**

Visus darbus veic kvalificēts personāls saskaņā ar attiecīgajiem kodiem un rīkojumiem.

NL **INSTALLATIE**

Alle werkzaamheden dienen te worden uitgevoerd door bevoegd personeel en volgens de geldende voorschriften en verordeningen.

NO **INSTALLASJON**

Alt arbeid må utføres av kvalifisert personell og i samsvar med gjeldende bestemmelser.

PL **INSTALACJA**

Całość prac montażowych musi zostać wykonana przez odpowiednio wykwalifikowany personel, zgodnie z obowiązującymi przepisami i zaleceniami.

PT **INSTALAÇÃO**

Todo o trabalho deve ser efectuado por pessoal qualificado, em conformidade com os códigos e regulamentos aplicáveis.

RO **INSTALARE**

Toate lucrările trebuie efectuate de personal calificat, în conformitate cu normele și reglementările în vigoare.

RU **МОНТАЖ**

Все работы должны выполняться квалифицированным персоналом в соответствии с инструкцией.

SK **INŠTALÁCIA**

Všetky činnosti musia byť vykonávané kvalifikovanou obsluhou a musia byť v súlade s príslušnými nariadeniami a kódmi.

SL **NAMESTITEV**

Vsa dela mora izvesti usposobljeno osebeje v skladu z veljavnimi predpisi in odloki.

RS **ИНСТАЛАЦИЈА**

Сви радови морају бити изведени од стране квалификованог особа и у складу са одговарајућим правилима и уредбама.

TR **MONTAJ**

Tüm işlemler kalifiye personel tarafından, geçerli kurallara ve yönetmeliklere uygun şekilde gerçekleştirilmelidir.

UK **УСТАНОВЛЕННЯ**

Усі роботи мають виконуватися кваліфікованим персоналом згідно з відповідними процедурами та стандартами.

i

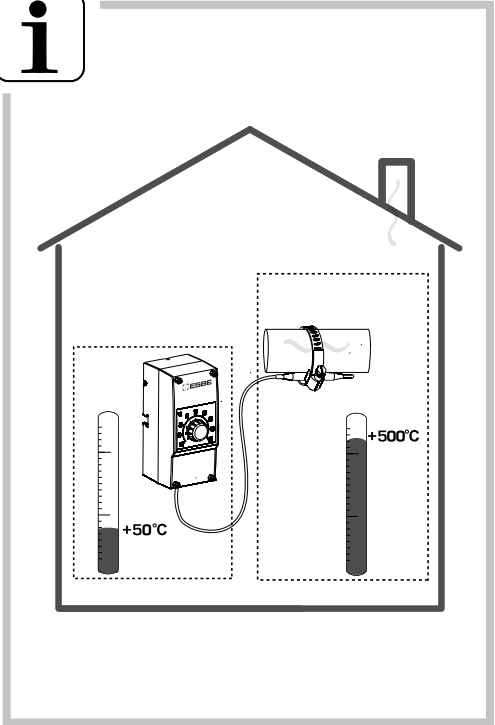

1

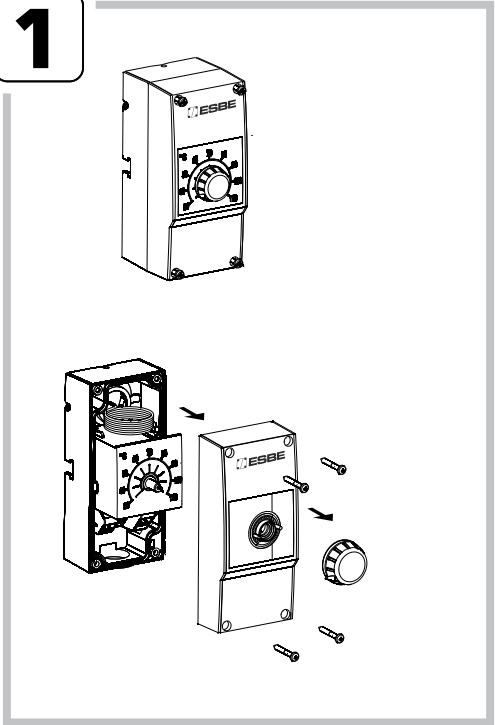

2

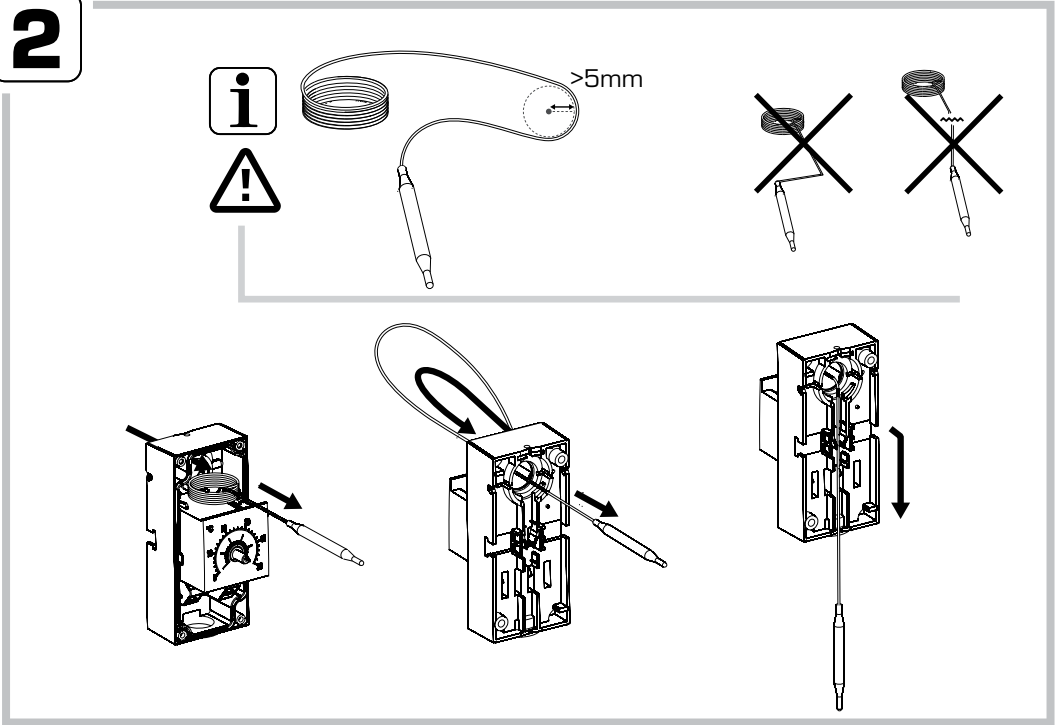

3

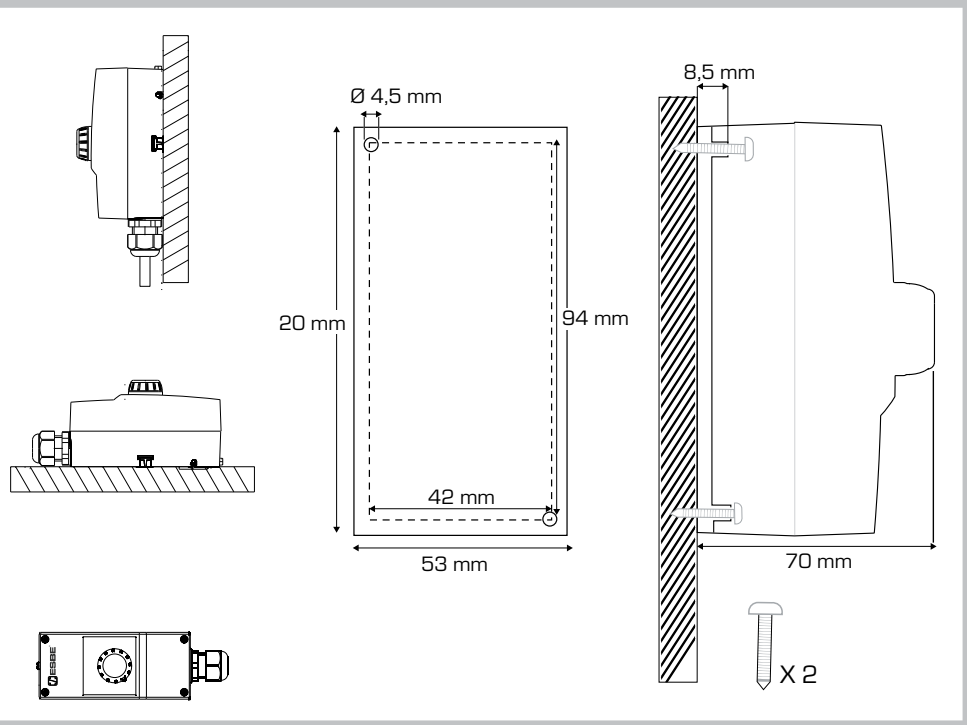
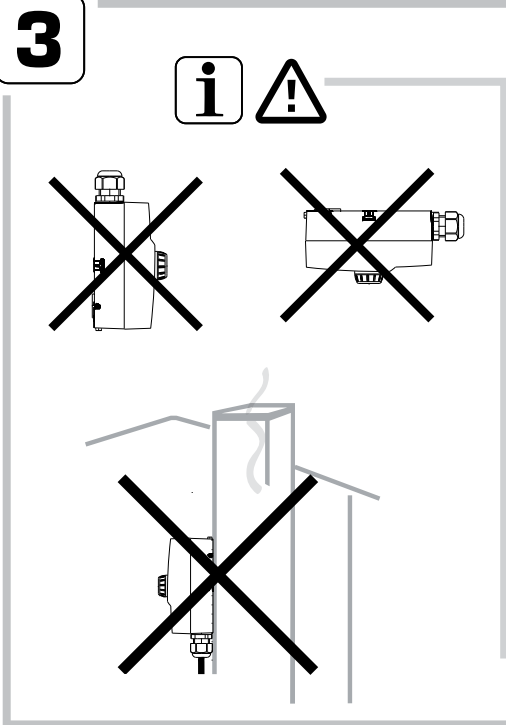

i

IP54

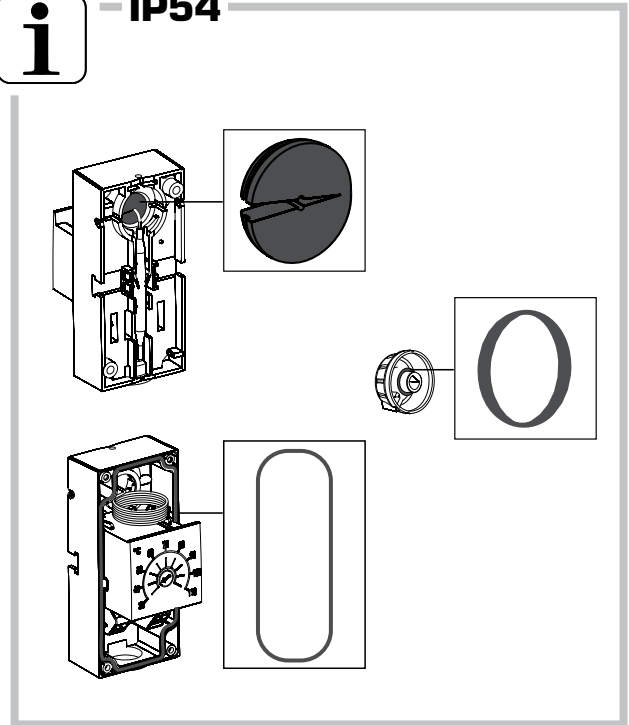

4 - CTF151

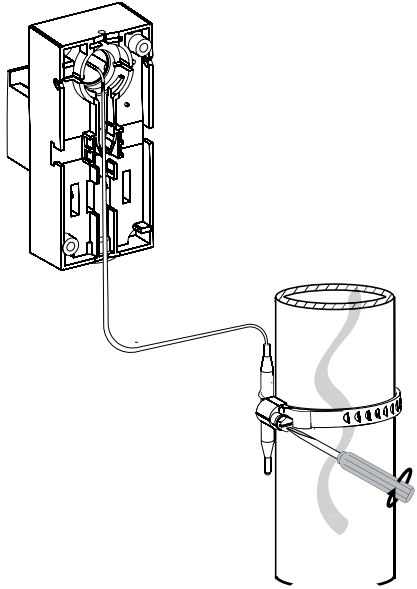

5 - CTF151, CTF851

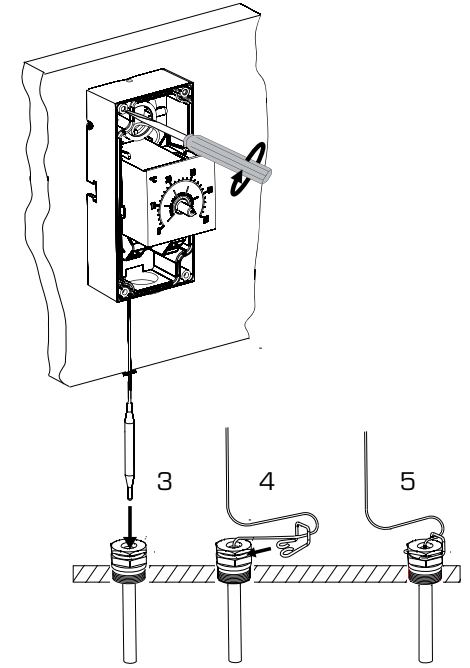
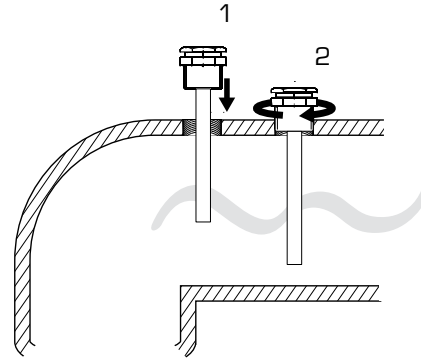
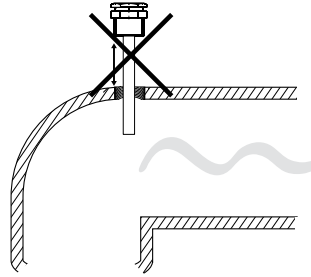

6 ~~⚡~~

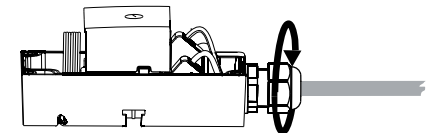
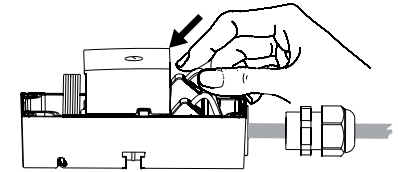
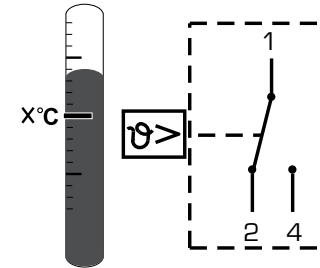
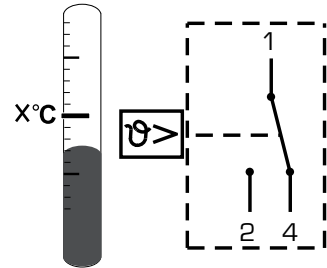
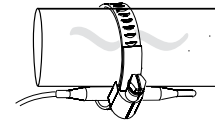
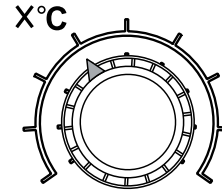
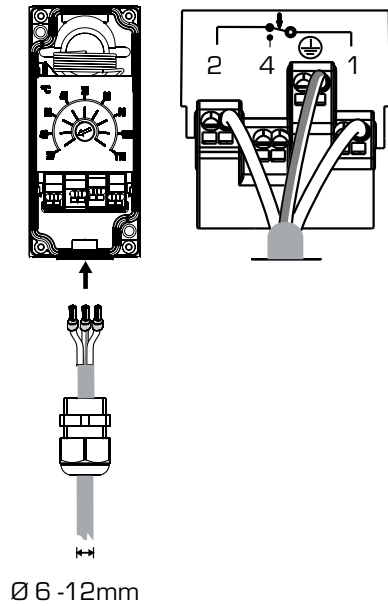
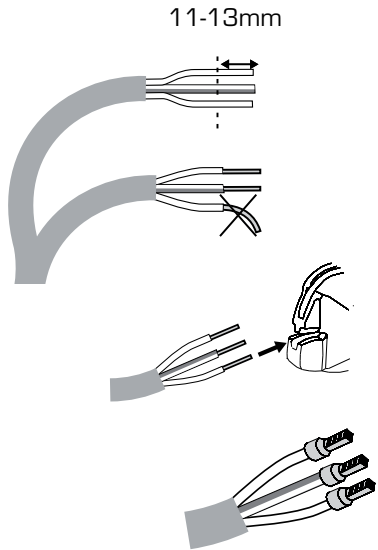

7

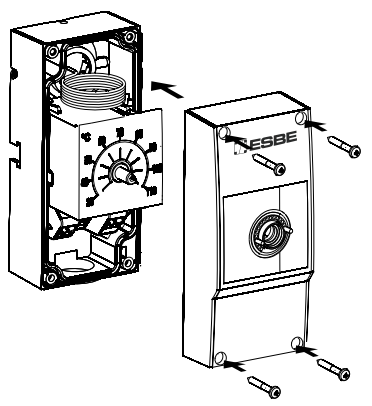

8

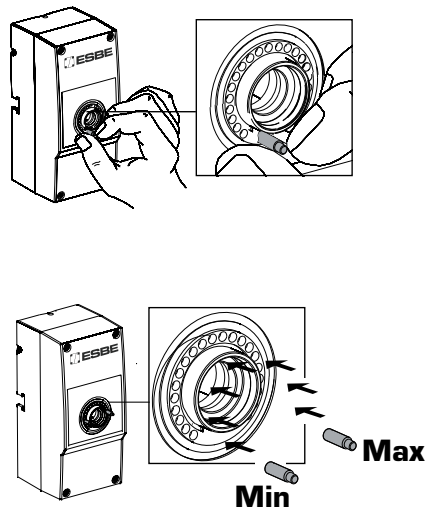

9

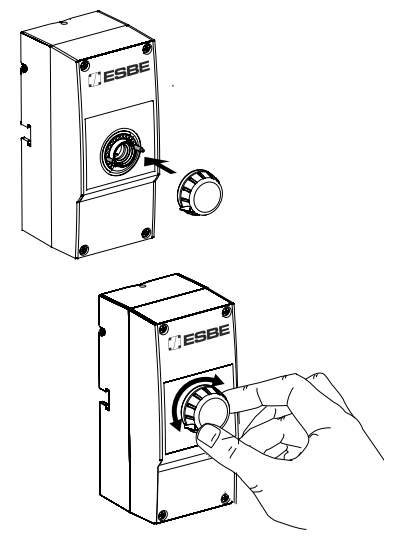

i

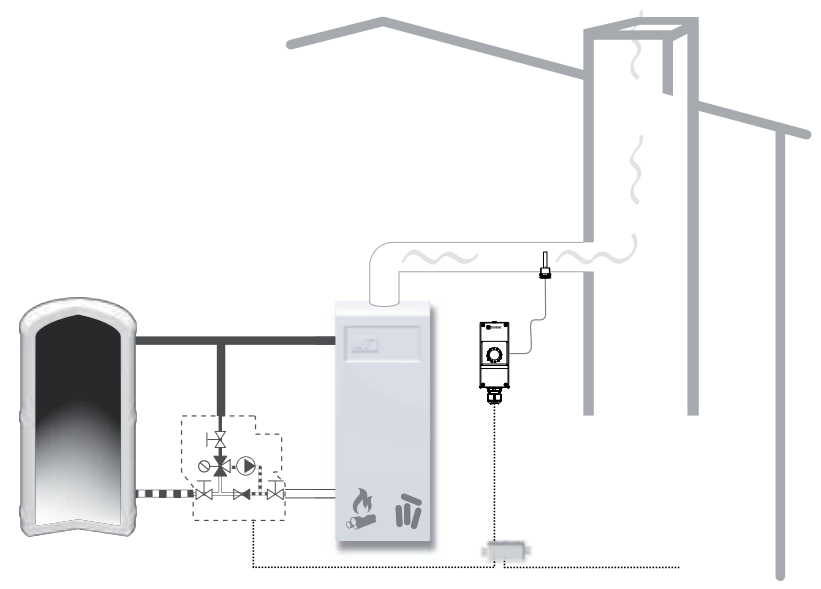

i

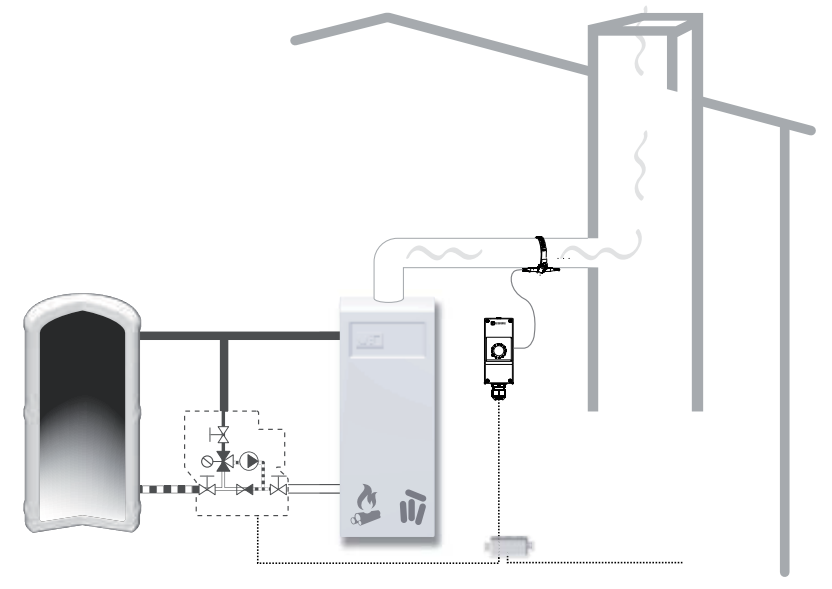

Piping Schematics are General Representations