

DC inverter split type heat pump

Installation & User Manual

Model: EV-DCS6 / EV-DCS9
EV-DCS12 / EV-DCS15
EV-DCS18

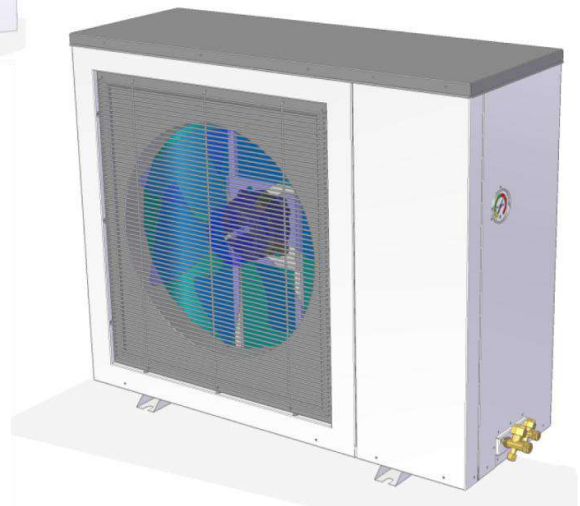
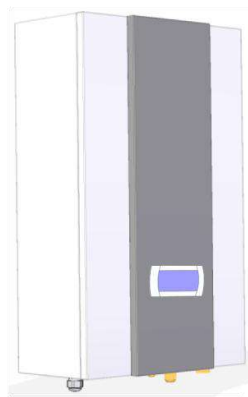

CE RoHS

Please properly keep this manual.
Please read this manual carefully before using the machine.

Content

1. Safe precautions	1
2. Structure	2
3. Installation	6
4. Electric connection	16
5. User instruction	17
6. Comon control functions	22
7. Trial operation	27
8. Unit operation and performance	28
9. Maintenance and trouble shooting	30
10. Wiring diagram	32

 Warning

The safety of you and your families is the most important !

This machine belongs to class I equipment.
Please ensure the reliable grounding before using it.

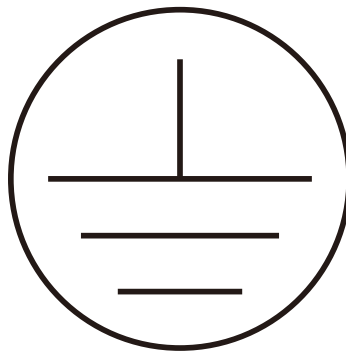

Note: Please don't use this machine if there is no grounding or the grounding is not reliable
If you are not sure if the grounding is reliable, please let the professional to check.

Please carefully read the safety precautions and notes about the machine before using it.

All the important notes and warning have the corresponding marks, the following is the meaning of the marks.

 Attention ! There is potential risk to cause the physical injury.

 Warning ! Please strictly obey the instructions, otherwise there would be life danger and serious injury.

1. Safety Precautions

Warning

Requirements for the installation environment

The installation location must be ventilated, waterproof, sun-proof, and requires a convenient power supply, water supply and drainage channels.

Customer's electrical environment must be in accordance with local electrical safety regulations.

The power supply specifications conform to the requirements of the local rating. There must be reliable grounding, leakage protector and give the machine power supply directly by the leakage switch wiring way.

The wall or stand must meet the bearing requirements

The installation, maintenance and renovation must be done by the designated dealer and professionals.

If the operator does not have relevant professional knowledge and authorization, but install and repair to result in the damage on furniture and decoration, injury or electric shock, and even serious accidents such as fire, we'll not assume legal responsibility.

The requirement on installation accessories

Please use the accessories in the packing according to the requirement, do not replace them with any other similar.

The purchased parts must be the designated model or specification, if the parts beyond the specified are used and result in the accidents, we'll not take the responsibility.

Attention

The household power supply, circuit to comply with relevant standards

The power circuit should be equipped with leakage protector.

Check whether the socket is qualified, after the unit runs for half an hour, remove the plug, if the pin is hot, that means the plug has more than 50 °C and must be replaced by another qualified one.

The location of the power supply should be not less than 1.8 meters from the ground, and be water-proof well and far from children.

The power lines have no damage. If there is any damage, please contact the relevant dealer or professional staff for replacement.

The unit should be installed firmly to run without vibration and the noise will not affect the neighbors.

Drainage piping can smoothly drain and will not lead to leakage or make the furniture wet.

The installation space is well ventilated, once there is refrigerant leakage, the gas will not gather, so there is no combustible gas leak near the installation location.

If there is such risk, please change the installation environment, otherwise, it's easy to cause poisoning, fire accident, etc.

Do not keep the unit in the humid environment or exposed to the rain, otherwise it's easy to damage the unit.

If there is refrigerant leak during the installation, ventilation measures must be taken immediately. Otherwise, if the leaked refrigerant meets fire, such as heater, stove or electric rice cooker, etc., poisonous gas maybe produced.

2. Structure

2-1 Outer Structure (Indoor Unit)

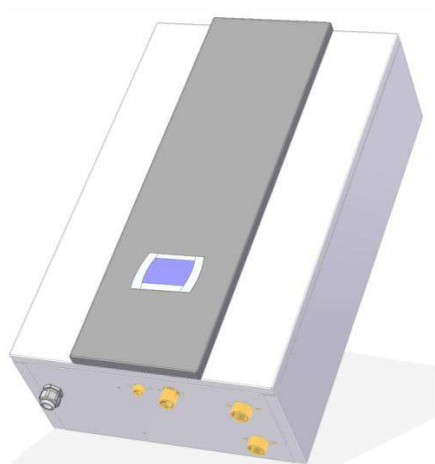
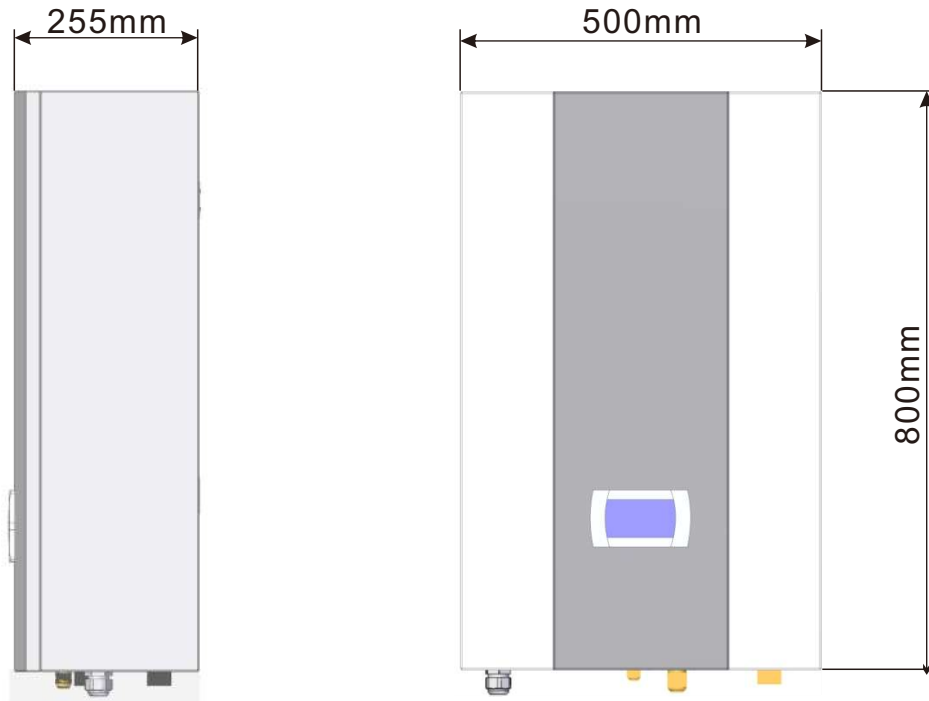

Picture 2.1

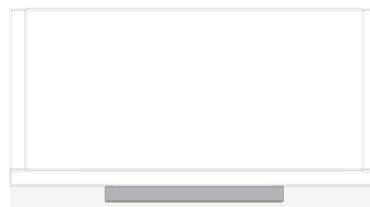

- 1-Controller
- 2-Liquid connection
- 3-Through hole
- 4-Gas connection
- 5-Water inlet
- 6-Water outlet

The photo in this manual is only for explanations purpose. If the appearance, function are not in accordance with the real one, please in kind prevail.

2. Structure

2-2 Outer Structure (Outdoor Unit)

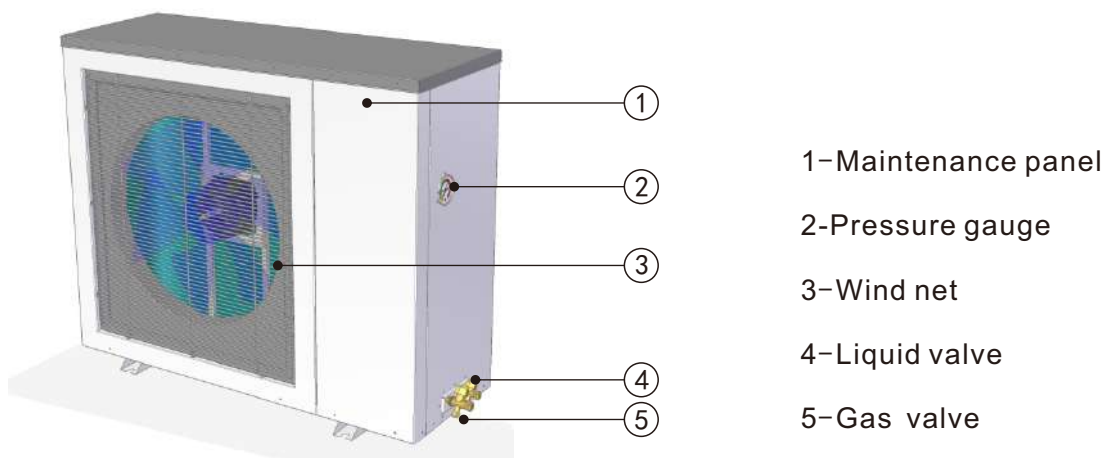
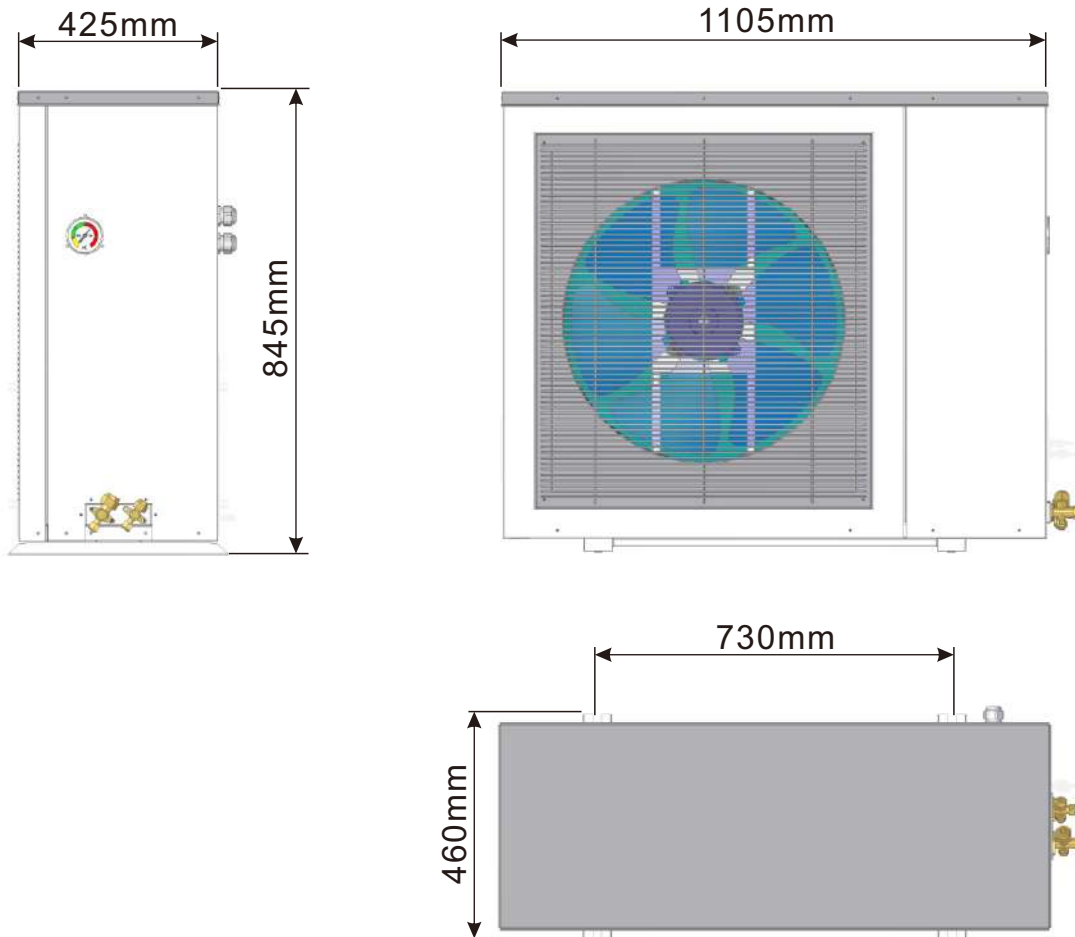

Picture 2.2

Model : EV-DCM9

2. Structure

2-3 The main components name (Indoor unit)

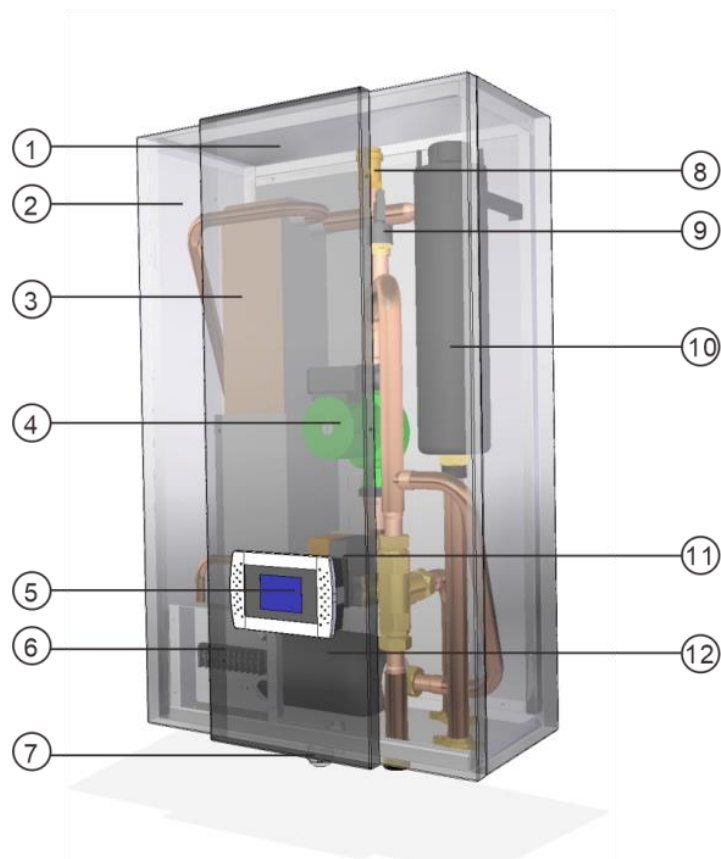

1	Indoor unit front panel	7	Hole for wire connection
2	Indoor unit case	8	Automatic vent valve
3	Plate heat exchanger	9	Water flow switch
4	Water pump	10	Electrical heater
5	Controller	11	3-way valve
6	Indoor terminal block	12	Expansion tank

Remark: The photo in this manual is only for explanations purpose. If the appearance, function is not in accordance with the real one, please in kind prevail.

2. Components name

2-4 The main components name (Outdoor unit)

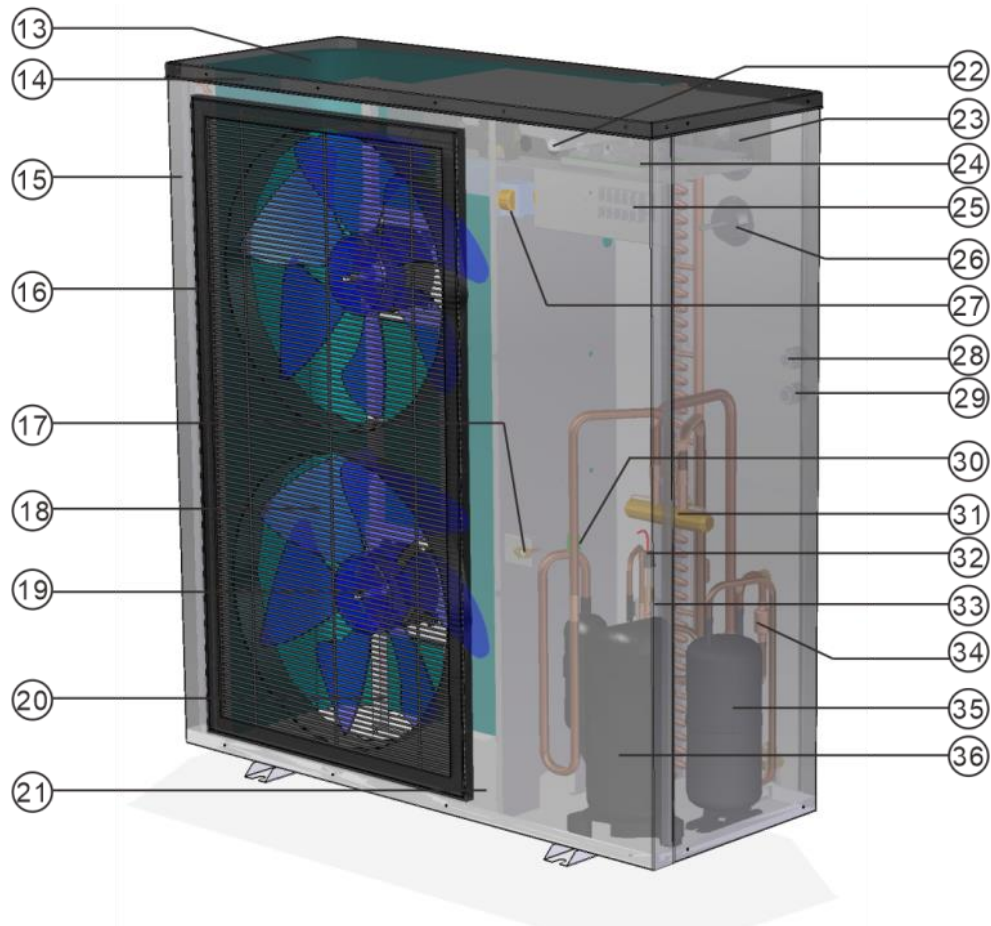

13	Evaporator	25	Outdoor terminal block
14	Outdoor unit top panel	26	High pressure gauge
15	Outdoor unit front panel	27	Reactance
16	Wind net	28	Hole for power cable
17	Service valve	29	Hole for control wire
18	Fan blade	30	Low pressure switch
19	Fan motor	31	4-way valve
20	Motor bracket	32	High pressure switch
21	Chasis	33	Electronic expansion valve
22	Inverter driver	34	Filter
23	Low pressure gauge	35	Separator
24	Main board	36	DC inverter compressor

3. Installation

Attention

The following installation places may cause the malfunction of the machine

The places where there is mineral oil;
The place that contains salt in the air, such as the seaside;
The place that contains corrosive gas, such as hot spring area;
The place where the powers supply voltage fluctuates seriously;
In the car or cabin etc.;
The place where is full of oil gas and oil spray, such as the kitchen;
The place where there is strong electromagnetic waves;
The place where exists flammable gas or material;
The place where there is acidic or alkali gas evaporation;
Other places where belongs to special environmental conditions

3-1 The choice of the installation location

The unit can be installed on the balcony or external wall; meanwhile, please waterproof measures should be done well.

There is sufficient space for installation and maintenance.

There is no barrier in front of the heat pump air outlet and strong wind can't blow there.

The installation place should be well ventilated and avoid the environment where there is flammable, explosive gas and strong corrosive gas.

The installation place should be convenient to install the pipe and electric wiring.

The bearing surface is flat, can withstand the unit weight and doesn't increase the vibration and noise.

If the installation base is metal parts, insulation treatment must be done well, and to comply with relevant standards

The running noise and discharge cold air will not affect yourselves and your neighbors

The high voltage and strong magnetic field should be avoided.

There should be no water logging in the installation place.

The unit should be blocked up to install if sundries or snow may accumulate in the installation place.

3. Installation

3-2 Movement

- 1) Because the gravity center of the unit is not in the middle, when you move the machine, please beware of the drumming.
- 2) Please do not hold the air inlet, or it will be deformed.
- 3) In the movement, please don't touch the fan blade by hand or other things in order to prevent from the damage on the fan blade.
- 4) Please don't lean it more than 45°C or lie it down.
- 5) Please try to use the auxiliary equipment, such as the forklift or crane to prevent the body injury caused by the overweight in the movement of the big models such as 15kw, 18kw.

Warning

Determine the feasible moving path.
Please try to move the unit under the condition of the original
Install the accessories according to the requirements..

3-3 Installation

The installation should be done by the qualified dealer or professional technicians.
If the installation is improper, it may cause the water leak, current leak or accidents such as fire.

The installation bearing surface should be flat and can support the weight of the unit.
Please install the unit firmly by using the MB expansion valve to fix it on the stand and anti-vibration rubber pads should be used to prevent the abnormal vibration and noise.

Please try to remove the barrier around the unit, otherwise the air circulation range will be too small and affect the performance.

If the unit is installed in the basement, indoor or in the other closed space, good air circulation between the unit and outdoor should be ensured. For 8kw model, the circulated air volume needs to be more than 1800m³/h. For 11~12kw model, the circulated air volume needs to be more than 2500m³/h. For 17kw model and 24kw model, the circulated air volume needs to be more than 4500m³/h. For 34kw model, the circulated air volume needs to be more than 6300m³/h.

If the unit is installed at the seaside or in the high place where there is strong wind, to make sure the normal operation of the fan blade, it must be installed against the wall. If necessary please use the baffle.

In the place where there is strong wind, please make sure the air outlet of the unit and the strong wind are the same direction, in order to prevent the strong wind blow to the indoor unit and affects the performance. If the wind direction can't be ensured, please put baffle in front of wind net of the air outlet.

Attention

When the unit is moved to another place, the movement and installation should be done by the professionals.

If the user installs the unit on their own, we'll not be responsible for the accidents such as the fire, current leak, etc.

3. Installation

3-4 The space of installation and maintenance

Please leave enough maintenance space as the below before the installation.

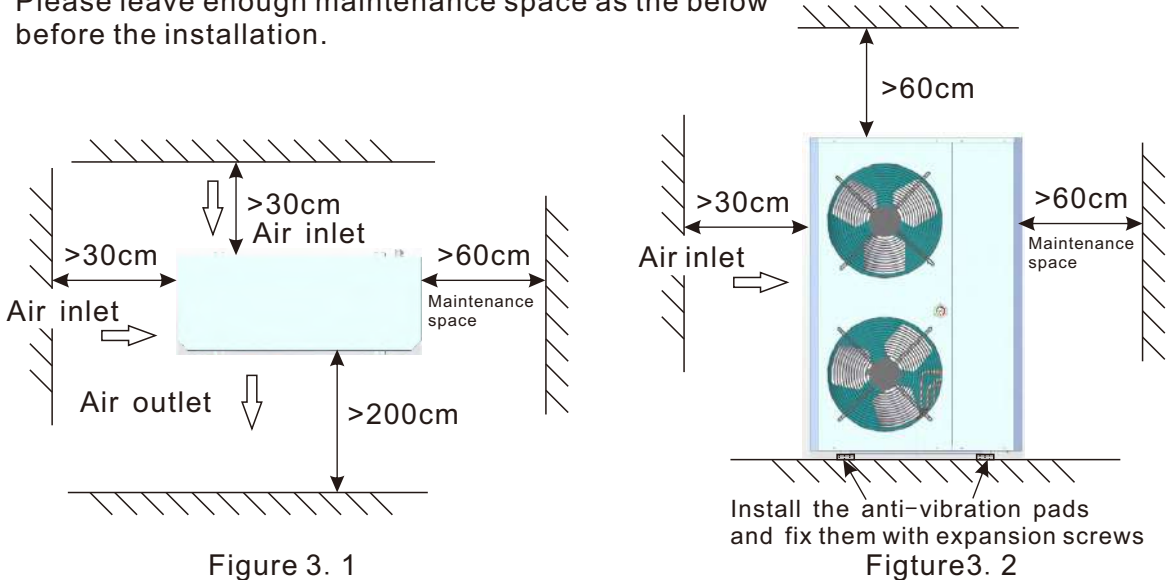

Figure 3. 1

Figure3. 2

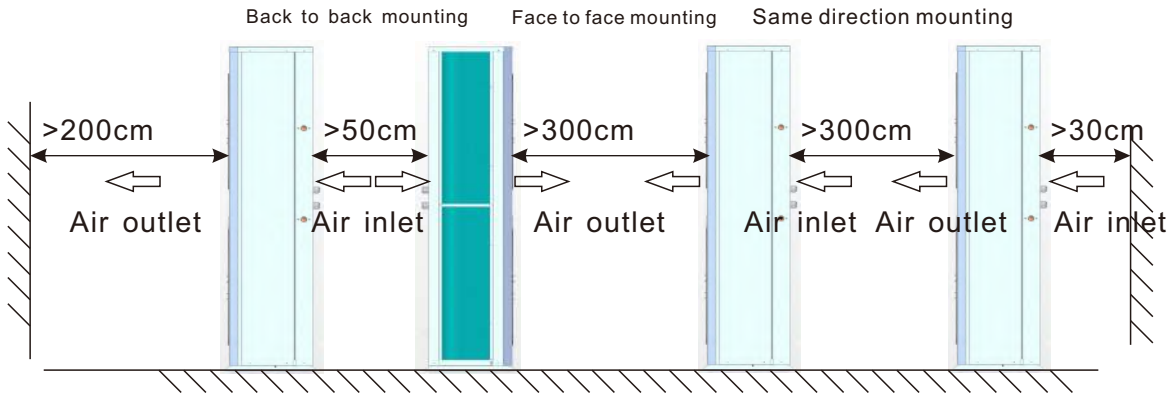

Figure3. 3

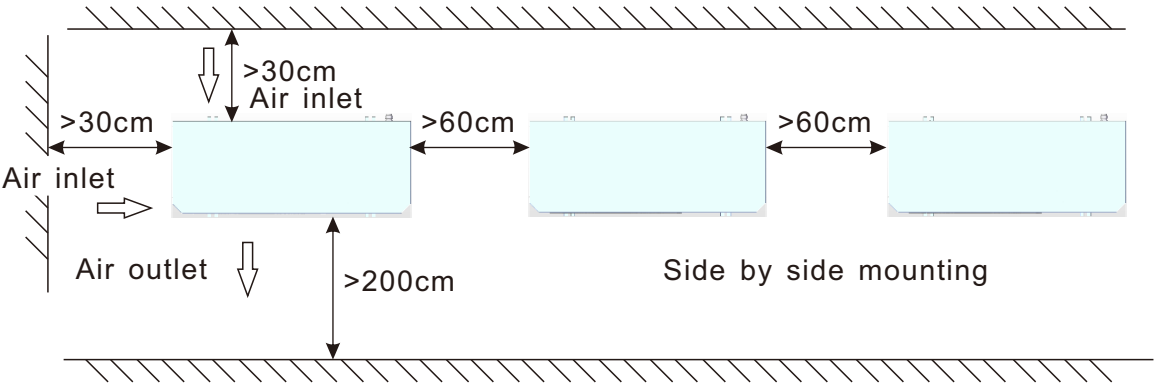
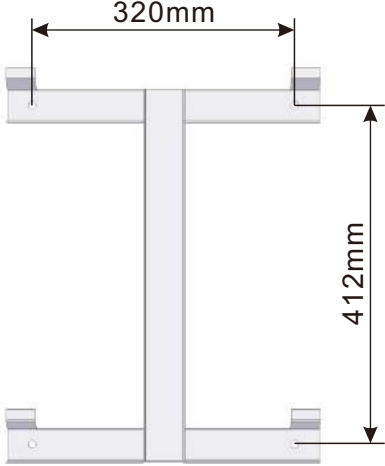

Figure 3. 4

3. Installation

3-5 The space of installation and maintenance for the indoor unit



The indoor unit needs to be mounted on the wall through the hanging plate. The fixed dimension of the hanging plate refer to the picture 3.5.

Picture 3. 5

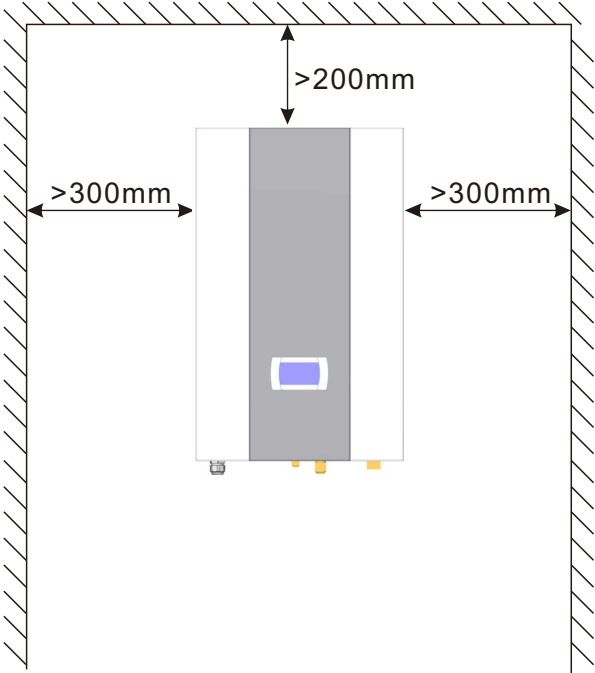

Picture 3. 6

Please leave enough maintenance space for the indoor unit as the above before the installation.

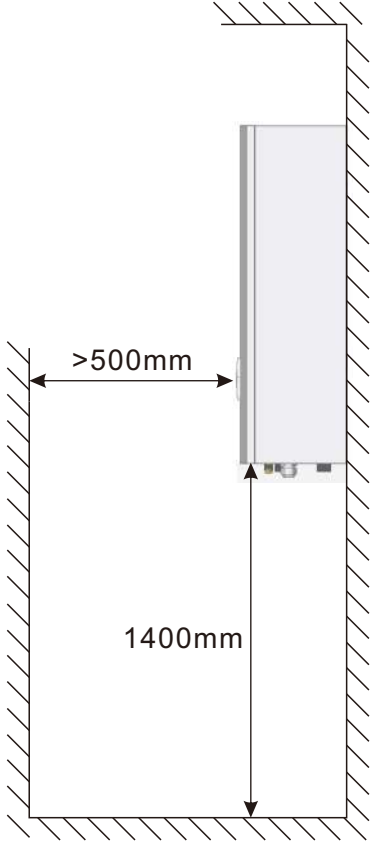

Picture 3. 7

3. Installation

3-6 Installation of the indoor unit

- 1) Use a percussion drill to drill four holes in the wall, the dimension of the holes refer to the picture 3.5
- 2) Fix the four expansion bolts in the four mounting holes, refer to the picture 3.8.
- 3) Put the hanging plate onto the expansion bolts, and tighten with the nuts, refer to the picture 3.9.
- 4) Hang the indoor unit on the hanging plate, pay attention to aim the hole on the back, refer to the picture 3.10.

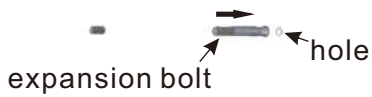

Picture 3. 8

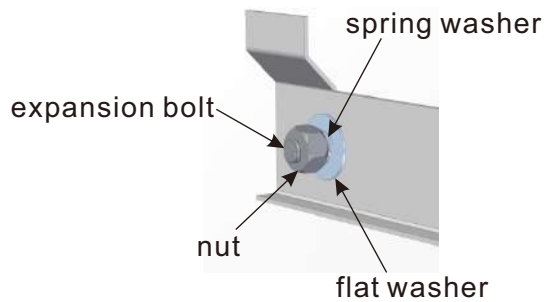

Picture 3. 9

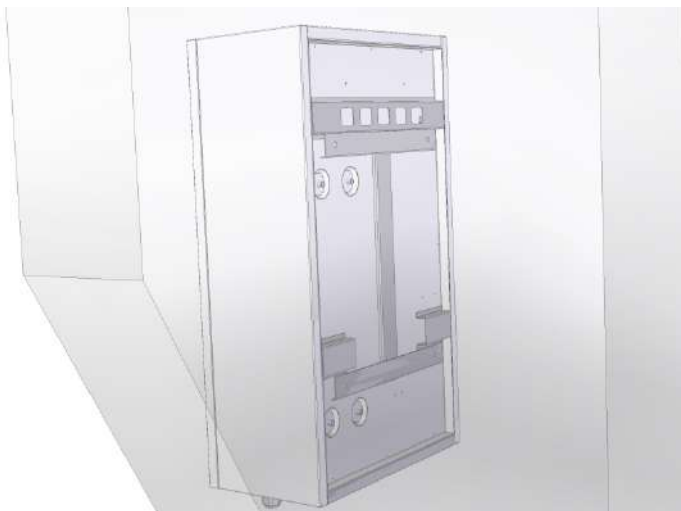

Picture 3. 10

3. Installation

3-7 Unit piping and wiring

Install the pipes according to the following methods.

- 1) Place outdoor unit and indoor unit firmly, and install one end of the refrigerant connecting pipes to the connectors on indoor unit.
- 2) Pull the other end of the refrigerant connecting pipes to the outdoor unit, shown as picture 3-11.
- 3) Connect the refrigerant pipes connectors to the outdoor unit, firstly screw the nuts by 3~4 cycles by hand.
- 4) Discharge all the air from the pipes.
- 5) Open the check valves on the outdoor unit, at this time the indoor unit and outdoor unit is linked by the refrigerant connecting pipes.
- 6) Check all connectors between indoor unit and outdoor unit, to make sure no leakage.

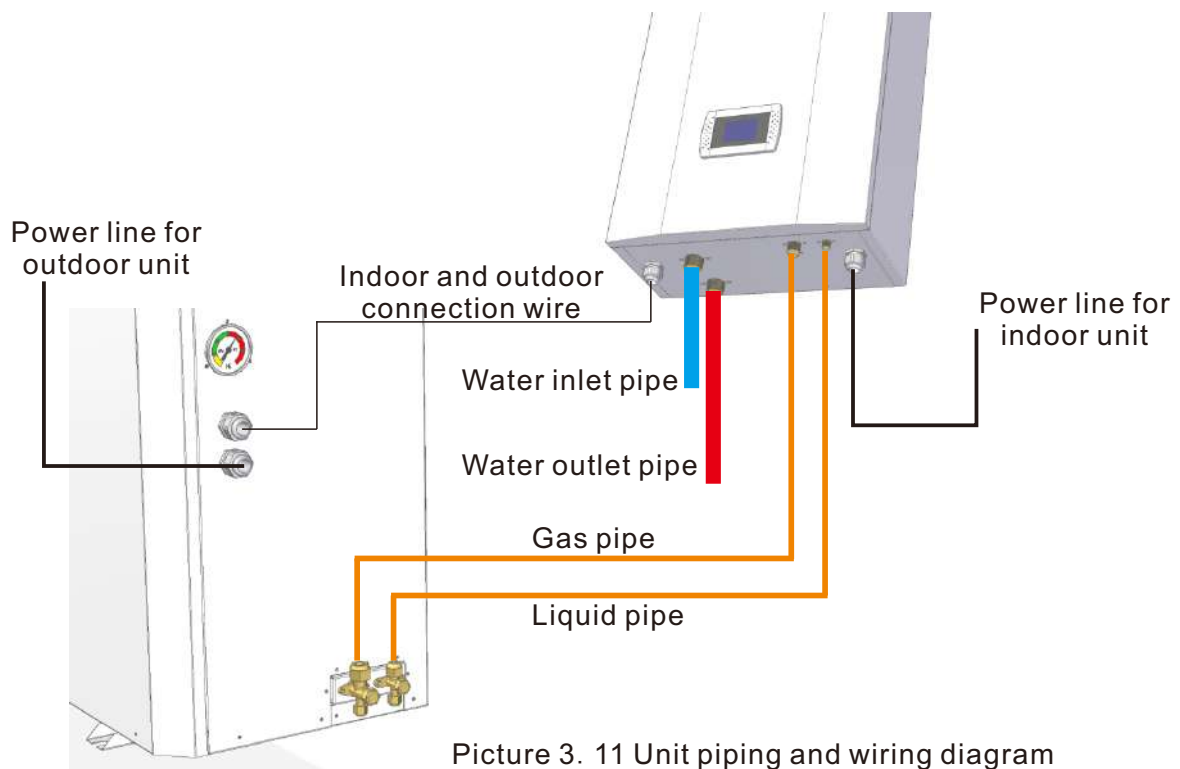

Picture 3. 11 Unit piping and wiring diagram

Note:

Be careful when bending the pipes. Do not bend too much causing damage, and do not damage the insulation.

Add some refrigerant oil onto the flare connectors and the nuts before tightening the nuts, to seal the connectors and avoid leakage (The refrigerant oil must match the refrigerant type).

The check valve at the outdoor unit should be OFF 100% (ex-factory status).

If it is necessary to bend the connecting pipes, bend the pipes with as big a bend radius as possible, to avoid being flattened and damaged.

3. Installation

3-8 Installation of the water pipes

1) To reduce the resistance of the water pipe as much as possible, reducing the elbow position and variable diameter can be adopted.

2) In the process of the piping connection, please make sure the whole system to be clean, no rust and no other dirt, in order to prevent the piping blockage.

3) Leak test should be done after the piping connection is finished. The test should focus on the screw thread connection to ensure the whole system without leakage, then thermal insulation should be done.

4) After all the piping are connected and tested leakage, 20mm thick thermal insulation must be packed on the piping in order to reduce the heat loss and prevent the water pipe freezing in winter.

5) Expansion tank needs to be installed in the highest point of the water circuit. The water level of the expansion tank should be at least 0.5 M higher than the highest point

6) Check the water flow of the water circuit system to ensure the normal water flow rate. If there is water flow fault, check the installation of the water circuit system. In order to make sure the protection on the unit when the system has no water, do not bridge the water flow switch casually.

7) Auto vent valve should be installed in the highest point of the water circuit, to prevent the air trapping which will affect the operating effect.

8) Thermometer and pressure gauge should be installed for the water inlet and water

3-9 Water injection and evacuation

1) Vent valve needs to be installed in the highest point of the water circuit system and drain valve needs to be installed in the lowest point of the water circuit system.

2) When the installation is finished, please keep the power supply off.

3) When the inlet valve is opened, the water injection begins. At this time, please keep the vent valve open, the air in the system will be evacuated via the vent valve outlet, and there is sound "tehee" from the vent valve.

4) Double check all the connections and elbows of the water circulation system, make sure there is no leak.

5) If there is no leak, then start the water pump to run the water circuit and double check if there is leak from the connections and elbows.

6) When the sound "tehee" disappears from the vent valve, the water injection is finished and water pump can be stopped, then prepare to energize the unit and start it.

3. Installation

3-10 Antifreezing measures

- 1) When the ambient is lower than minus 5°C , please make sure the unit is energized.
- 2) The unit is set with anti-freeze protection program, in the state of power on, when the ambient temp gets to the protection value, the unit will run the water pump automatically and even start the heating to prevent the freeze of the water circuit, in order to make sure the normal operation of the system.
- 3) If the unit can't be energized for a long time, please make sure the water in the buffer tank and water circuit system is totally drained to prevent from the freezing of the water system and the damage on the unit.
- 4) If the power failure or power off happen, and the water is not timely drained from the water circuit system, then cause the damage on the unit and crack of the water system, our company will not take the responsibility of the maintenance.

Warning

In the situation of the power failure or power off, if the water circuit is not timely drained, it will cause the crack of the water pipe system, even damage the heat exchanger and compressor, and then the whole system will scrap, so please strictly obey the anti-freeze requirements.

Attentions

Choose one of the water supply valves to install.
 The temp of the water supply to the buffer tank needs to be less than 50°C.
 The water quality needs to meet the requirements in the following table, otherwise, the heat exchanger and the floor heating pipes will scaling after a period of using. It will affect the heat exchange efficiency

Ph value	total hardness	conductivity	sulfide	chloridion	ammonia ion
6.5-8.0	200 μ V/cm(25°C)	<50ppm	No	<50ppm	No
sulfate ions	silicon	iron content	sodion	calcium ion	_____
<50ppm	<30ppm	<0.3ppm	no requirement	<50ppm	_____

3. Installation

3-11 Installation diagram

a. Installation for only heating

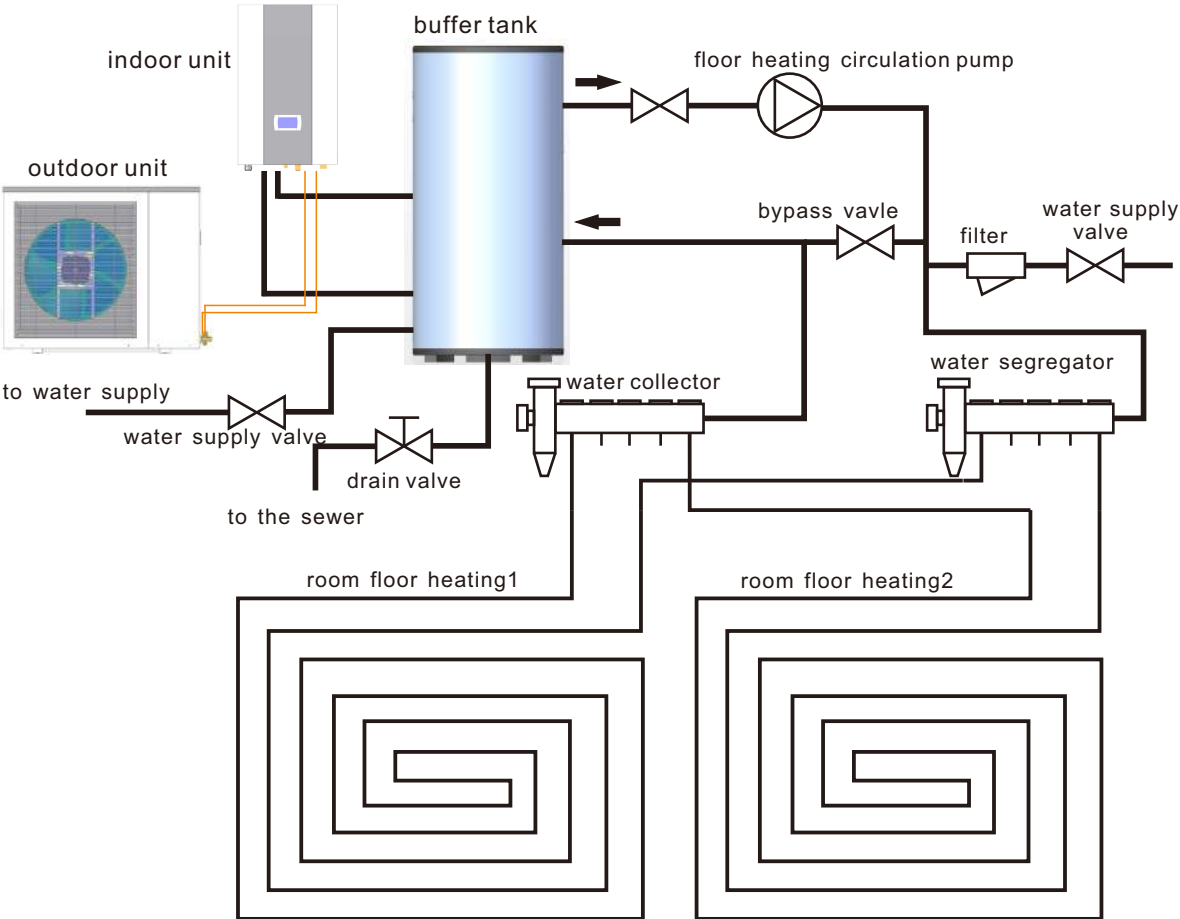

b. Installation for only hot water

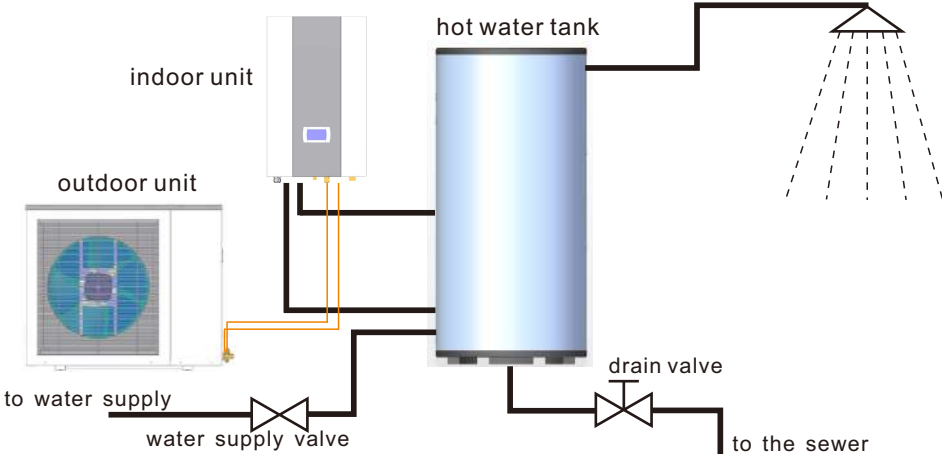

3. Installation

c. Installation for hot water & heating

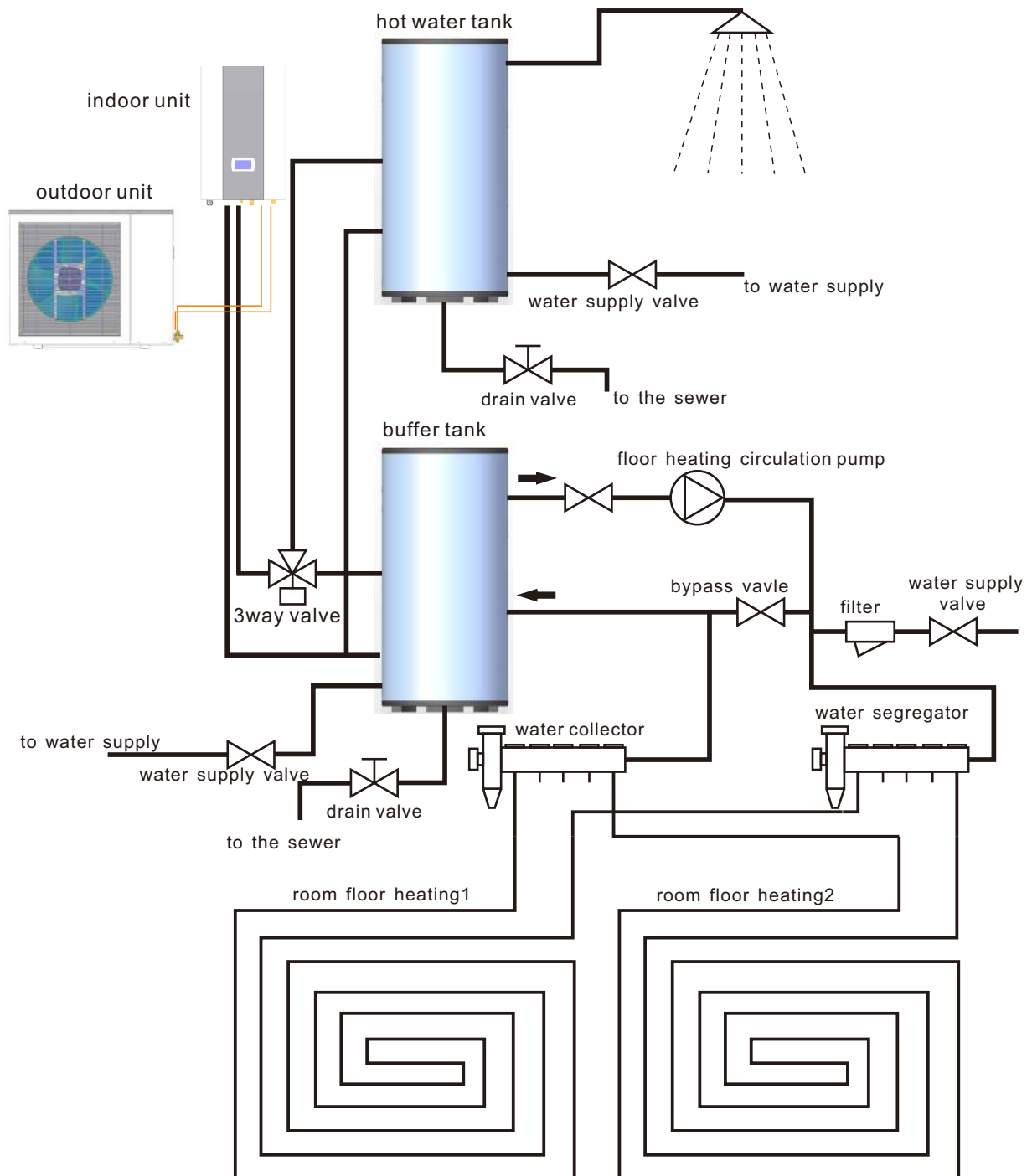

Picture 3. 12 recommended installation way

4. Electric connection

4-1 Electric wiring



Attention

- 1) The unit should use the dedicated power supply; the power supply voltage should consist with the local rules of the rated voltage.
- 2) The external power supply circuit must have grounding and the unit power supply grounding wire should be connected to the external grounding wire reliably.

4-2 Electric wiring steps

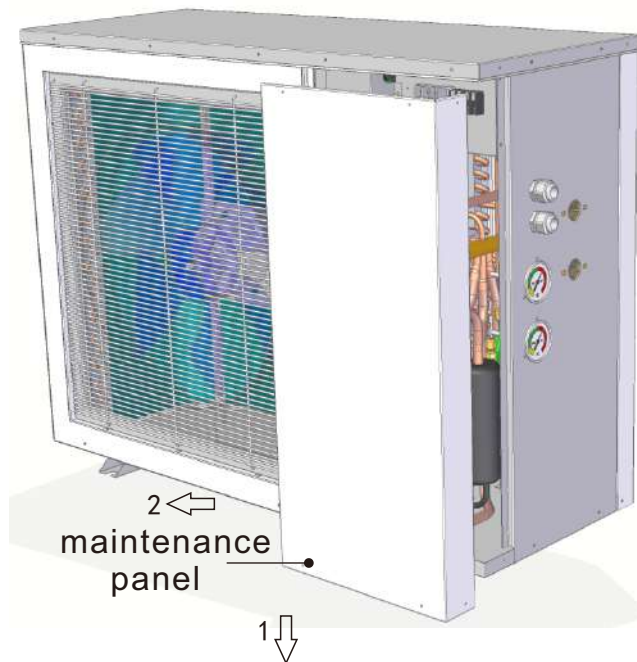

- 3) The electrical wiring construction must be carried out by the professional technician based on the circuit diagram.
- 4) The leakage protection device must be set up in accordance with the local relevant technical standard of the electrical equipment.
- 5) The power supply line and the signal line should be arranged reasonably and neatly. They can't interfere with each other and contact with the connection pipe and valve body.
- 6) When all the wiring construction is finished, the power should be connected after all is checked to be no problem.

Remove the screws of the maintenance panel, push it down off the top panel, then take it out.

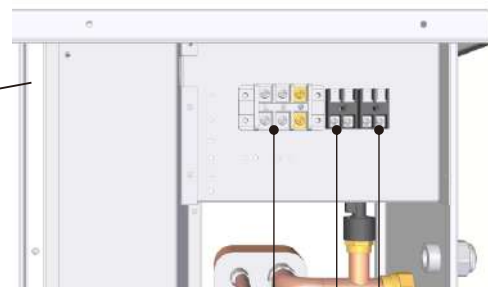
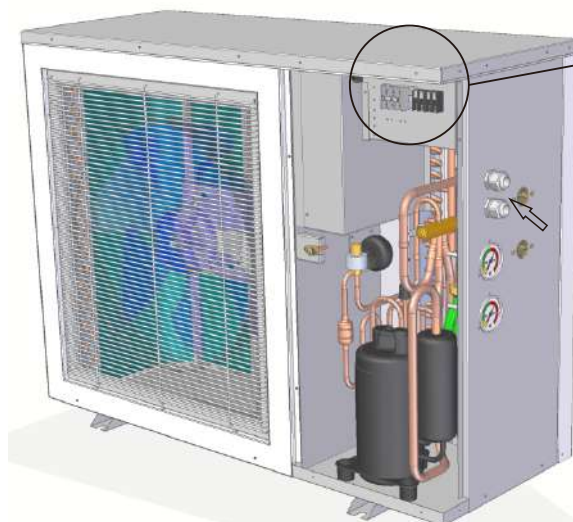

1. Power supply
2. Connect with 3-way valve (If the model has this function)
3. Connect with electrical heater (If the model has this function)

Through the power line from the hole, and connect the line with the terminal.

5. User instruction

5-1 Controller key description

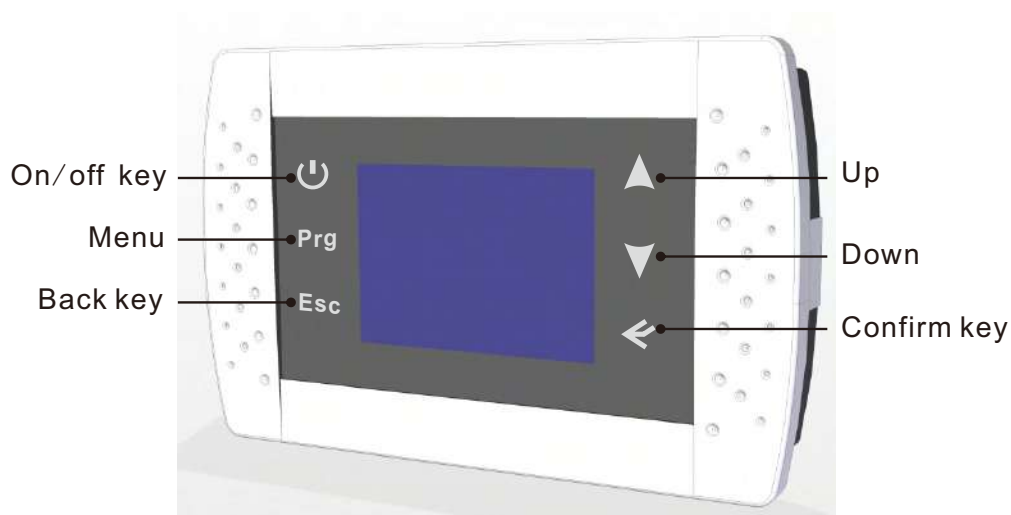

Figure 5. 1

- 1) On/off key: Press this key to choose to turn on or turn off the unit.
- 2) Menu: In main interface, press this key to enter into the menu. Hold this key for 5s to start the manual sterilization function.
- 3) Back key: At menu stage, press this key to return to upper level menu and at the same time confirm the parameter adjustment. Hold this key for 5s to start the manual defrost.
- 4) Up: In each parameter page, press up key to select the last parameter; in the parameter setting page, press this key to add the parameter setting value.
- 5) Down: In each parameter page, press down key to select the next parameter; in the parameter setting page, press this key to reduce the parameter setting value.
- 6) Confirm key: In the page of menu, after select the parameter, press confirm key to enter into the selected parameter page, In the parameter setting page, after the adjustment of the parameter, press this key to confirm the parameter setting. Hold this key for 5s to lock/unlock keys.

5. User instruction

5-2 Menu and parameters

In main interface, press Prg key to enter into the menu. All unit status and parameters are in this menu. There are 5 main menus, as follows:

- Function setting
- Parameter setting
- Failure records
- Time setting
- Temp. curve display

Main menu 1: Function setting

Sub-menu	Parameter	Meaning	Range	Default	Remark
Mode select	DHW	Domestic hot water mode	ON/OFF	OFF	Adjustable
	DHW temp.	Domestic hot water mode setting temperature	30~55°C	50°C	Adjustable
	BTW temp.	Heating mode setting temperature	Heating: 18~60°C Cooling: 8~28°C	25°C	Adjustable When it is set to AUTO heating, the setting temp. is with A in the front, and the setting temperature changes as per outdoor temperature.
Unit status	DHW temp.	DHW tank temperature	-30~99°C		Actual value
	BTW temp.	AC heating tank temperature	-30~99°C		Actual value
	BTW inlet temp.	Water inlet temp.	-30~99°C		Actual value
	BTW outlet temp.	Water outlet temp.	-30~99°C		Actual value
	Heating coil	Heating coil temp.	-30~99°C		Actual value
	Exhaust coil	Compressor discharge temp.	0~125°C		Actual value
	Evap. temp.	Compressor suction temp.	-30~99°C		Actual value
	Ambient temp.	Outdoor ambient temp.	-30~99°C		Actual value
	Expansion valve	EEV steps	100~480N		Actual value
	EVI inlet temp.	EVI circuit gas inlet temp.	-30~99°C		Actual value
	Solar water temp.	Solar tank temp.	-30~99°C		Actual value
	IPM temp.	Inverter radiator temp.	-30~99°C		Actual value
	Comp. Freq.	Compressor speed	0~90Hz		Actual value
	Comp. Current	Compressor current	0~50A		Actual value
	Comp. type	Compressor unit type	1~8		Actual value
	EVI outlet temp.	EVI circuit gas outlet temp.	-30~99°C		Actual value
	EVI valve	EVI circuit EEV steps	0~480N		Actual value
DC. voltage	DC voltage			Actual value	

5. User instruction

Main menu 2: Parameter setting (requiring password)

Sub-menu	Parameter	Meaning	Range	Default	Remark
1. System parameter	1.1 DHW ΔT .	DHW temp. drop for restart	1~20°C	5°C	Adjustable
	1.2 BTW ΔT .	AC heating temp. drop for restart	1~20°C	2°C	Adjustable
	1.3 EEV Overheat/C	AC heating target superheat	-20~20°C	1°C	Adjustable
	1.4 EEV Overheat/H	AC cooling target superheat	-20~20°C	1°C	Adjustable
	1.5 EEV Mode	EEV mode	Auto/Manual	Auto	Adjustable
	1.6 BTW pump	Circulating pump mode	0-always on/1-off/ 2- Intermittent operation	0	Adjustable
	1.7 Disinfection	Disinfection function	ON/OFF	OFF	Adjustable
	1.8 Spray Valve	Spray valve starting temp.	0~20°C	8°C	Adjustable
	1.9 EH start temp.	Outdoor ambient temp. to start the pipe electric heater	-17~7°C	-5°C	Adjustable
	1.10 BTW ΔT EH	Heating water temp. drop allowing to start pipe electric heater	0~15°C	2°C	Adjustable (this ΔT +AC ΔT)
	1.11 DHW ΔT EH	DHW temp. drop allowing to start DHW tank electric heater	0~20°C	5°C	Adjustable (this ΔT +DHW ΔT)
	1.12 EH start	DHW tank electric heater start delay	10~90M	30M	Adjustable
	1.13 Initial step	EEV initial steps	150~500N	200N	Adjustable (see 8.6.1)
	1.14 Adjust step	EEV manual steps	30~500N	250N	Adjustable, adjusting accuracy change to 2P
	1.15 DHW tank factor	DHW tank heat exchange correction	1~10	10	Adjustable
	1.16 Frequency code	Compressor speed code	1~8	3	Adjustable

5. User instruction

Sub-menu	Parameter	Meaning	Range	Default	Remark
2. Defrost parameter	2.1 Def. Cycle	Defrost interval	30min~90min	40min	Adjustable
	2.2 Def. start temp.	Coil temp. to start defrost	-20~5°C	-7°C	Adjustable
	2.3 Def. stop temp.	Coil temp. to quit defrost	1~30°C	10°C	Adjustable
	2.4 Def. Max. time	Max. defrost duration	1min~12min	8min	Adjustable
3. inverter parameter	3.1 Comp. control	Compressor speed control	Auto/manual	Auto	Adjustable
	3.2 Comp. Freq.	Compressor speed by manual	30~90	50	Only for manual
	3.3 Exhaust TP0	Discharge temp. protection setting TP0	50~125°C	96°C	
	3.4 Exhaust TP1	Discharge temp. protection setting TP1	50~125°C	102°C	
	3.5 Exhaust TP2	Discharge temp. protection setting TP2	50~125°C	106°C	
	3.6 Exhaust TP3	Discharge temp. protection setting TP3	50~125°C	110°C	
	3.7 Exhaust TP4	Discharge temp. protection setting TP4	50~125°C	114°C	
	3.8 Current limit I	Current limited to rise	5~50A	20A	
	3.9 Current limit II	Current to speed down compressor	5~50A	22A	
	3.10 Current limit III	Current to stop heat pump	5~50A	25A	
4. Solar parameter	4.1 Solar system	Solar assistant system	ON/OFF	OFF	Adjustable
	4.2 Solar mode	Solar heating mode	Heating / DHW / DHW+Heating	Heating	Adjustable
	4.3 Start ΔT	Temp. drop to start solar	1~30°C	15°C	Adjustable
	4.4 Hysteresis	Correction for Hysteresis	1~10	5	Adjustable
	4.5 Max. Tank T	Tank max. temp.	50~99°C	90°C	Adjustable
5. EVI parameter	5.1 EVI function	5.1 EVI function	ON/OFF	OFF	
	5.2 Start Air Temp	5.2 ambient temp. for EVI starts	-5~20°C	7°C	
	5.3 Start ΔT	5.3 Temperature difference to start EVI	20~60°C	38°C	temp. difference between heating coil and cooling coil

5. User instruction

Sub-menu	Parameter	Meaning	Range	Default	Remark
5. EVI parameter	5.4 EEV overheat	5.4 target superheat	1~15	6	
	5.5 EEV mode	5.5 EEV mode	Auto/manual	Auto	
	5.6 Initial step	5.6 EVI EEV initial step	0~480	30	Adjusting accuracy is 2P
	5.7 Adjust step	5.7 EVI EEV manual step	0-480	30	
Change password	Change password	change the password to query system parameters		0000	
Restore default set	Restore default set	Recover to default setting	When this is selected, hold confirm key for 3 second to reset all parameters back to default value.		

Main menu 3: Failure records Main menu 4: Time setting

Main menu 4: Time setting

Main menu 5: Temp. curve display

Sub-menu	Parameter	Meaning	Range	Default	Remark
Main menu 3: Failure records					
Failure records	Controller can record the latest 8 error codes.				Only for checking
Main menu 4: Time setting					
Time setting	Date 2019-01-01	Date			Adjustable
	Clock 18:30	Time			Adjustable
	Timer on X	Timer on			Adjustable
	Timer off X	Timer off			Adjustable
Main menu 5: Temp. curve display					
Temp. curve display	BTW temp.	AC tank temp. curve	-30~99°C		Actual value
	DHW temp.	DHW tank temp. curve	-30~99°C		Actual value
	Ambient temp.	Ambient temp. curve	-30~99°C		Actual value

6. Common control functions

6-1 Circulating pump

The unit receives signal to turn on, circulating pump starts 5min before compressor does.

- 1). The unit receives signal to turn off, circulating pump stops 5min after compressor does.
- 2). Circulating pump keeps on during defrosting.
- 3). Compressor stops after reaching set temperature, circulating pump keeps on when AC demand signal is on regardless parameter setting. When AC demand signal is off, circulating pump operates according to parameter 1.6(BTW PUMP) as follows:

BTW Pump (Para.1.6)=0, keeps on after reaching set temperature;

BTW Pump (Para 1.6)=1, stops 5min after compressor stops;

BTW Pump (Para 1.6)=2, operates as per ambient temperature after reaching set temperature and compressor stops:

When outdoor temp. is at (+2°C, +∞), circulating pump keeps off when unit stops;

When outdoor temp. is at (-2°C,+2°C), circulating pump stops for 20min, then runs for 10min, and operates in this cycle;

When outdoor temp. is at (-6°C,-2°C), circulating pump stops for 15min, then runs for 水15min, and operates in this cycle;

When outdoor temp. is at (-10°C,-6°C), circulating pump stops for 10min, then runs for 20min, and operates in this cycle;

When outdoor temp. is at (-∞, -10°C), circulating pump keeps on.

When outdoor temp. sensor is error, circulating pump stops for 15min, then runs for 15min, and operates in this cycle;

6-2 Electric heater (AC electric heater)

- 1). Conditions for switching on electric heater:
 - Starts in defrosting mode;
 - Starts in secondary anti-frozen protection;
 - There is protection acting in heating mode;
 - In heating mode, ambient temp. ≤ set value for switching on electric heater;
 - Heating temp. ≤ heating set value – (Heating Delta T(Para. 1.2)+Heating electric heater delta T (Para. 1.10))
- 2). Conditions for switching off electric heater:
 - In heating mode, ambient temp. set value for switching on electric heater +2°C;
 - Heating sensor error or water flow switch error;
 - Defrosting quits;
 - Secondary anti-frozen protection quits;
 - Not at the heating mode;
 - Heating water temp. T heating tank ≥ Heating set temperature;

6. Common control functions

2. Heating mode

1). AC heating mode

1.1) Heating water temperature set

- When set to AUTO(para. 02 set to 1), set temperature runs as per heating curve, please refer to "AUTO heating" function.
- When set to manual, heating water temperature set value T_{SETH} range 18-65°C, default 25°C

1.2) Heating operation

- 3-way valve dis-energized, 4 way valve energized, water pump turns on.
- Outdoor fan has 2 speeds, and runs as per outdoor temperature.
- In manual heating mode, compressor turns on/off as per the AC water tank temperature T_{WB2} and heating water set value T_{SETH} .
- In manual heating mode, when the above condition is not matched, compressor turns on/off as per the actual water temperature, set temperature and the Delta T.
- With the water pipe electric heater function (refer to the introduction on pipe electric heater control)

2). Auto heating mode

Auto heating mode and heating curve

2.1) when Parameter BTW in mode selection is set to heating(manual), controller regulates heating water temperature as per existing logic, that is BTW temp. setting, and keep the heating water temperature at the set value.

Initial BTW Temp and Max. BTW Temp do not display.

2.2). When Parameter BTW is set to auto heating, the controller regulates heating water temperature as per the heating curve.

With "A" displayed before heating symbol in controller.

Parameter BTW temp. in heating mode displays as set room temp.(set range 15~25°C).

Parameter Initial BTW temp does not change (set range 15~25°C).

Parameter Max. BTW temp (set range 24~50°C).

2.3). In AUTO heating mode, AC tank target temperature is regulated as per heating curve, and heating curve is determined by Set room temp., initial BTW temp., max BTW temp. and outdoor ambient temp.

6. Common control functions

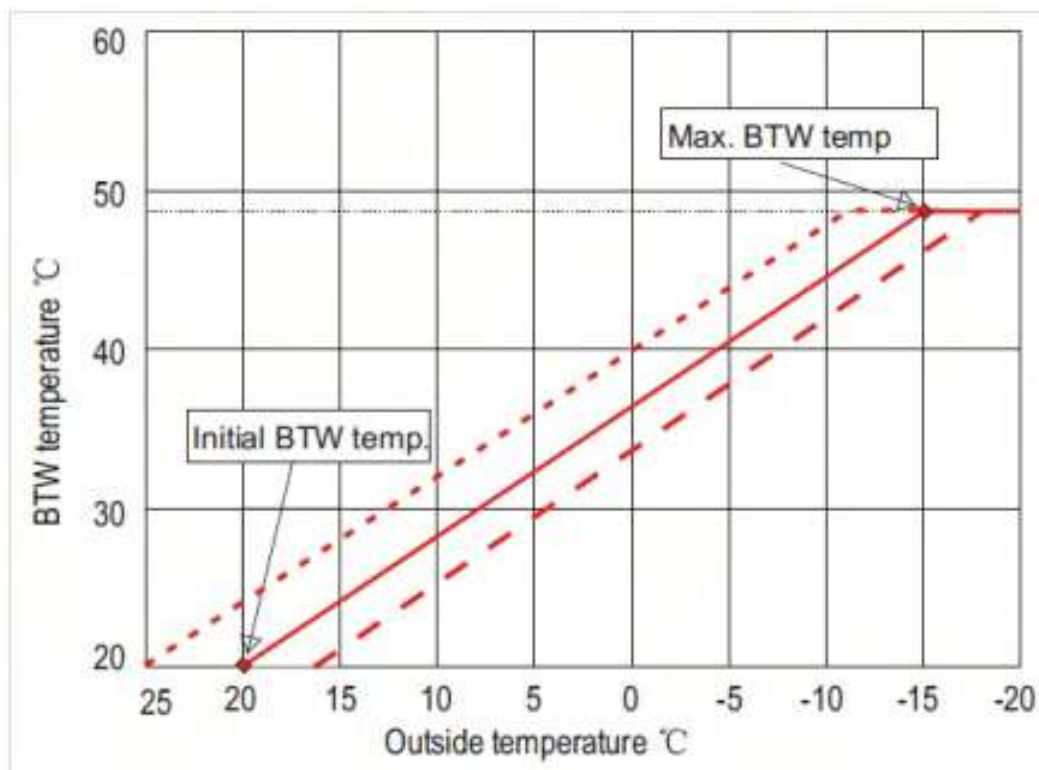

Formula as follows:

AC tank target temp.= Initial BTW temp + (Max BTW temp – initial BTW temp)/35 x (Set room temp – outdoor temp.)

note : $15^{\circ}\text{C} \leq \text{AC tank target temp.} \leq 60^{\circ}\text{C}$

for example : set room temp = 20°C

Max BTW temp= 48°C

Initial BTW temp= 20°C

At the following outdoor temp. the AC tank target temp. is:

- Outdoor temp.= 20°C , AC tank target temp.= $20+(48-20)/35 \times (20-20)=20^{\circ}\text{C}$
- Outdoor temp.= 0°C , AC tank target temp.= $20+(48-20)/35 \times (20-0)= 36^{\circ}\text{C}$
- Outdoor temp.= -15°C , AC tank target temp.= $20+(48-20)/35 \times (20+15)= 48^{\circ}\text{C}$

Note:

- 1> Max BTW temp and initial BTW temp are for controlling the heating curve slope, and Set room temp is for controlling the heating curve parallel move.
- 2> Auto heating mode comparing with heating mode, the difference is just the calculating of the AC tank target temperature. In heating mode the target temperature is fixed, while in Auto heating the target temperature changes as per the heating curve. While the compressor on/off and Delta T control are completely the same in these 2 modes.

6. Common control functions

3. DHW mode

3.1 DHW temperature setting

DHW set temperature T_{WBSET} range 30-60°C, default set temperature 50°C.

3.2 Normal heating operation

- 3 way valve at water circuit is energized, and 4-way valve is dis-energized, and circulating pump turns on.
- The outdoor fans have 2 speeds, and run at the speed according to ambient temperature.

- Compressor turns on/off as per DHW tank temp. T_{WB1} and the DHW set temp. T_{SETH} .

- With DHW tank electric heater function (refer to DHW tank electric heater control)

6-6 Solar assistant heating control

The solar assistant heating control is built in the indoor PCB and the wired controller panel.

Under the wire controller menu Parameter setting there is the menu Solar Parameters.

Control logic:

- When parameter Solar system is set to OFF, controller does not check solar temperature sensor, does not receive or report errors.
- When parameter Solar system is set to ON, controller thinks the system is connected to solar assistant system. Controller reports error as long as solar temperature sensor is disconnected or short-circuit, but it does not influence the operation of heat pump, it just stops the solar circulating pump.
- Solar mode can be set to heating, DHW, or DHW+heating.
- The port OUT 5 on indoor PCB, is to control the 3-way valve for solar circuit, switching between DHW tank and AC heating water tank.
- When DHW mode is active, this 3-way valve is energized.
- In heating mode or DHW mode:

If the following conditions are matched at the same time, controller turns on the solar circulating pump (OUT3) and heats the AC heating tank.

- Heat pump is in heating or Auto heating mode (as long as this mode is selected by controller and heat pump is at ON status, regardless standby status by reaching set temperature or not).
- Parameter Solar system is set to ON.
- Parameter Solar mode is set to heating or DHW+Heating
- Solar sensor temp. – BTW temp. > Parameter Start ΔT

When solar sensor temp. – BTW temp. < Parameter Start ΔT – Hysteresis, or BTW temp. reaches the set value of Parameter Max Tank T (Max. tank temperature), controller stops the solar circulating pump.

If the following conditions are matched at the same time, controller turns on the solar circulating pump (OUT3) and solar 3 way valve, and heats the DHW tank.

6. Common control functions

- Heat pump controller is in DHW mode (as long as this mode is selected by controller and heat pump is at ON status, regardless standby status by reaching set temperature or not).

- Parameter Solar system is set to ON.
- Parameter Solar mode is set to DHW or DHW+Heating.
- Solar sensor temp. –DHW temp. > Parameter Start ΔT

When solar sensor temp. –DHW temp. < Parameter Start ΔT – Hysteresis or DHW temp. reaches Parameter Max Tank T set value (Max. tank temperature), controller stops the solar circulating pump.

6-7 Manual defrosting

When outdoor ambient temp. $T_{\text{outdoor}} \leq 15^{\circ}\text{C}$, the controller can be operated to do the manual defrosting by holding “ESC”.

The manual defrosting duration is the set duration, regardless the coil temperature.

6-8 DHW sterilization (when DHW mode is active)

- DHW sterilization is once every 7 days.
- When DHW sterilization function is operating, the DHW tank electric heater is turned on forcibly.
- DHW tank temp. $\geq 65^{\circ}\text{C}$, and keeps for 15 min $\geq 65^{\circ}\text{C}$, controller quits sterilization.
- When DHW sterilization function starts, it would forcibly quits this function if the DHW tank temp. fails to reach 65°C in 3 hours continuously.
- When DHW mode is active, hold “Prg” key for 10s and it starts the DHW sterilization function manually.
- When DHW sterilization is running, wire controller displays symbol “”.

6-9 Power cut memory function

- Parameters can be set, and controller always stores the setting.
- Controller can memory on/off status and electric heater status.
- If the electricity power is cut abnormally, or the unit is turned off, the controller would stays at the standby status or continues the previous status before electricity was cut.

6-10 AC demand switch

- When AC demand switch is on, AC modes are enabled.
- When AC demand switch is on, relay OUT1 is on. When AC demand switch is off, OUT1 is off.

When AC demand switch is off, AC modes are disabled, and on screen the symbol (cooling/heating symbol) flashes.

7. Trial operation

7-1 Inspection before the trial operation

Please check if the following items before the trial operation.

- 1) If the unit is installed correctly;
- 2) If the piping and wiring are correct;
- 3) If the drainage is smooth;
- 4) If the thermal insulation is well done;
- 5) If the grounding wire is connected properly;
- 6) If the power supply voltage fits the rated voltage of the unit;
- 7) If there is any barrier in front of the air inlet/outlet;
- 8) If the air inside the water circuit system is totally evacuated, if all the valves are opened;
- 9) The current leak protector can act effectively;
- 10) The inlet water pressure is no less than 0.15MPa.

7-2 Trial operation

When all the above items are normal, connect the power supply and start the unit.

During the trial operation, check the following items:

- 1) If the unit working performance is normal, if it can normally produce the demanded heating capacity or cooling capacity.
- 2) If the water connection is tightly fixed without water leak ;
- 3) If the fan blade runs normally; if the outlet air is smooth and if there is abnormal vibration from the fan motor;
- 4) During the unit running, if there is abnormal vibration and noise.
- 5) If the operation keys of the controller is flexible, reliable and responds normally.
- 6) If the controller display is normal, if there is missing or wrong segment, if the back light brightness is normal.
- 7) If there is any abnormal vibration and pipeline collision from the pipe system during the operation.
- 8) If the power line is hot abnormally during the unit operation;

If all the above is normal, the unit can be sent to the customer to put in use.

8. Unit operation and performance

8-1 explanation for some phenomena during the unit operation

1) Start delay;

During the unit running, if the unit is turned off or stops automatically, if restart the unit, the unit has to wait for 3 minutes to start. This setting is the protection on compressor instead of fault.

2) Defrosting ;

In the heating mode, when the outdoor evaporator surface has white frost (when the air temp is low or the air is humid, this phenomenon will be more obvious), the heat exchanging and performance will be affected, so when the frost gets to a certain degree, the system will run the defrosting automatically.

In the defrosting mode, the outdoor fan motor will stop run. Sometimes there is white vapor from the outdoor evaporator. Those are normal defrosting phenomenon instead of fault.

3) Antifreeze protection ;

In the cold winter, when the unit is standby mode, sometimes it will run the water pump automatically or even starts the compressor to run for a short time, in order to prevent the freezing of the water circuit at the low temp. Those are the antifreeze protection operation of the system instead of fault.

In the cold winter, if the unit is no longer used, please keep the unit energized. Please do not cut off the power supply, otherwise, it will be impossible to run the antifreeze protection mode and result in the water circuit freezing and damage on the unit.

If the unit will not be used for a long time, please make sure the water circuit system is completely drained before cutting off the power supply.

4) Fault displaying;

During the normal operation, if the unit suddenly stops, please immediately check the content displayed on the controller in order to make clear if it is the action of some protective device.

The unit system is set with many protection measures, if there is fault code on the controller displayer, please immediately contact your dealer or after service support to solve the problem.

5) Screen lock function ;

In the running of the unit, if the controller can't be operated, please check if the controller screen is locked. Please refer to the item 7) "screen lock setting" in the part of 5-2.

8-2 Notes about unit running

Please keep the air inlet/outlet surroundings clean, do not block the air inlet/outlet channel in order to not affect the heat exchanging efficiency.

Set a comfortable water temp instead of over-high water temp, otherwise it will cause the electricity waste and overload operation of the compressor, possibly also affect the life span of the unit.

In any case, if the unit has abnormal noise and over vibration, please immediately contact your dealer or after-sales technician.

If any problem happens during the operation, please contact your dealer or after-sales technician to solve the problem. Please do not try to dismantle machine or repair the machine by your own in order to avoid unnecessary injury.

8. Unit operation and performance

8-3 Performance parameter

Model			EV-DCM6	EV-DCM9	EV-DCM12	EV-DCM15	EV-DCM18
Power supply		V/Ph/Hz	220/1/50			220/1/50, 380/3/50	
Heating (A7 / W35)	Capacity	KW	6.5	9.1	12.5	15.5	18.2
	Power input	KW	1.45	2.00	2.84	3.6	4.20
	Rated current	A	6.6	9.1	13.0	16.4/6.1	19.1/7.1
	COP		4.48	4.55	4.40	4.31	4.33
Cooling (A35 / W7)	Capacity	KW	4.9	6.9	9.4	11.7	13.8
	Power input	KW	1.75	2.49	3.33	4.22	5.0
	Rated current	A	8.0	11.3	15.1	19.2/7.16	22.7/8.5
	EER		2.80	2.77	2.82	2.78	2.76
Electric heater		KW	3				
	Current	A	13.6				
Heating water range		°C	18 - 60				
Cooling water range		°C	8 - 28				
Operating air temperature		°C	-25 - 43				
Max. Discharge Pressure		MPa	4.2				
Max. Suction Pressure		MPa	1.2				
Refrigerant	R410A	Kg	1.6	2.05	3.2	3.6	4.4
Water pump	Input (L/M/H)	W	55/70/100	55/70/100	135/190/245	135/190/245	135/190/245
	Rated current	A	0.25/0.35/ 0.45	0.25/0.35/ 0.45	0.60/0.85/ 1.10	0.60/0.85/ 1.10	0.60/0.85/ 1.10
Outdoor air flow		m ³ /h	2500	2800	5600	5600	5600
Water flow rate		m ³ /h	1.05	1.6	2.1	2.9	3.1
Dimensions WxDxH	Indoor Unit	mm	550x255 x800	550x255 x800	550x255 x800	550x255 x800	550x255 x800
	Outdoor Unit	mm	1110x450 x850	1110x450 x850	1110x450 x1250	1110x450 x1250	1110x450 x1250
Net weight	Indoor/ Outdoor	kg	35/52	36/57	44/90	45/105	45/106
Noise level(1 M)		dB(A)	≤52	≤53	≤56	≤58	≤58

* The technical specifications of our heat pumps are provided for information purposes only.

We reserve the right to make changes without prior notice.

9. Maintenance and trouble shooting

9-1 Fault code table

Wire controller error	Meaning	Main PCB display
Standby		
Normal running		
Err 00	Communication error	
Err 01	Water inlet sensor error	1 flash 1 off
Err 02	Water outlet sensor error	2 flash 1 off
Err 06	Water flow protection	12 flash 1 off
Err 04	Phase order error	13 flash 1 off
Err 05	Water temperature difference between inlet and outlet is too big	16 flash 1 off
Err 07	Coil temp. is too high	17 flash 1 off
Err 08	DHW tank sensor error	3 flash 1 off
Err 09	AC tank sensor error	4 flash 1 off
Err 10	High pressure protection	10 flash 1 off
Err 11	Low pressure protection	11 flash 1 off
Err 12	Water outlet temp. is too high	14 flash 1 off
Err 13	Water outlet temp. is too low	19 flash 1 off
Err 14	Compressor suction temp. sensor error	7 flash 1 off
Err 15	Compressor discharge temp. sensor error	8 flash 1 off
Err 16	Compressor discharge temp. is too high	22 flash 1 off
Err 18/ Err 19	DHW/AC level 2 anti-frozen protection	21 flash 1 off
Err 20	Ambient temp. sensor error	9 flash 1 off
Err 21	Heating coil temp. sensor error	5 flash 1 off
Err 22	Cooling coil temp. sensor error	6 flash 1 off
Err 23	Ambient temp. is too high	18 flash 1 off
Err 31	Ambient temp. is too low	
Err 32	Indoor PCB communication error	
Err 33	EVI inlet temp. sensor error	
Err 34	EVI outlet temp. sensor error	
Err 35	Solar temp. sensor error	
E24	Inverter communication error	
E25	inverter abnormal protection	
E26	inverter radiator temperature is too high	
E27	compressor current is too high	
E28	inverter temp. sensor error	
E29	compressor overload protection	
E30	water inlet temp. is too low during defrosting	

9. Maintenance and trouble shooting

9-1 Malfunctions and treatment

Warning

If any fault occurs and the unit stops running, please contact your dealer or after-sales technician to solve the problem. Please do not dismantle the unit and do repair by your own in order to avoid any unnecessary injury.

When the unit has abnormal fault, please immediately cut off the power supply, do not force it to run, otherwise there will be more damage.

9-2 Cleaning

Warning

For the sake of safety, the unit must be turned off and the power supply is cut off before the cleaning.

Please take care to not damage the temp sensors during the cleaning.

- 1) Please be careful of those sharp metal edges and evaporator fins during the clearing to avoid the injury caused by improper operation.
- 2) Regularly check the air inlet and air out and see if there is any blockage.

9-3 Maintenance

Attention

When the unit is prepared to be put in use again after a period of leaving unused, please check the air inlet and air outlet to see if there is any blockage. If there is blockage, please clean up immediately.

- 1) Before the use of the unit in each season, Please clean the filter on the water circuit system to make sure the smooth water flow
- 2) During the unit operation, when the water flow is small and the water temp difference is too big, please check if the filter of the water circuit is clear.
- 3) Before the use of the unit in each season, please check if the heat exchanger surface is clean. If there is too much dirt or impurities, please contact your dealer or the after-sales serviceman to do the cleaning in order to make sure the good heat exchanging efficiency and using effect.
- 4) If there is plenty of snow in winter, please block up the unit before install it to avoid the blockage of the air outlet because of the deep snow.

9-4 After-sales service

When the unit can't work normally, please immediately turn off the unit and cut off the power supply, then contact the local dealer or professional technician to solve the problem.

10. Wiring diagram

Indoor unit

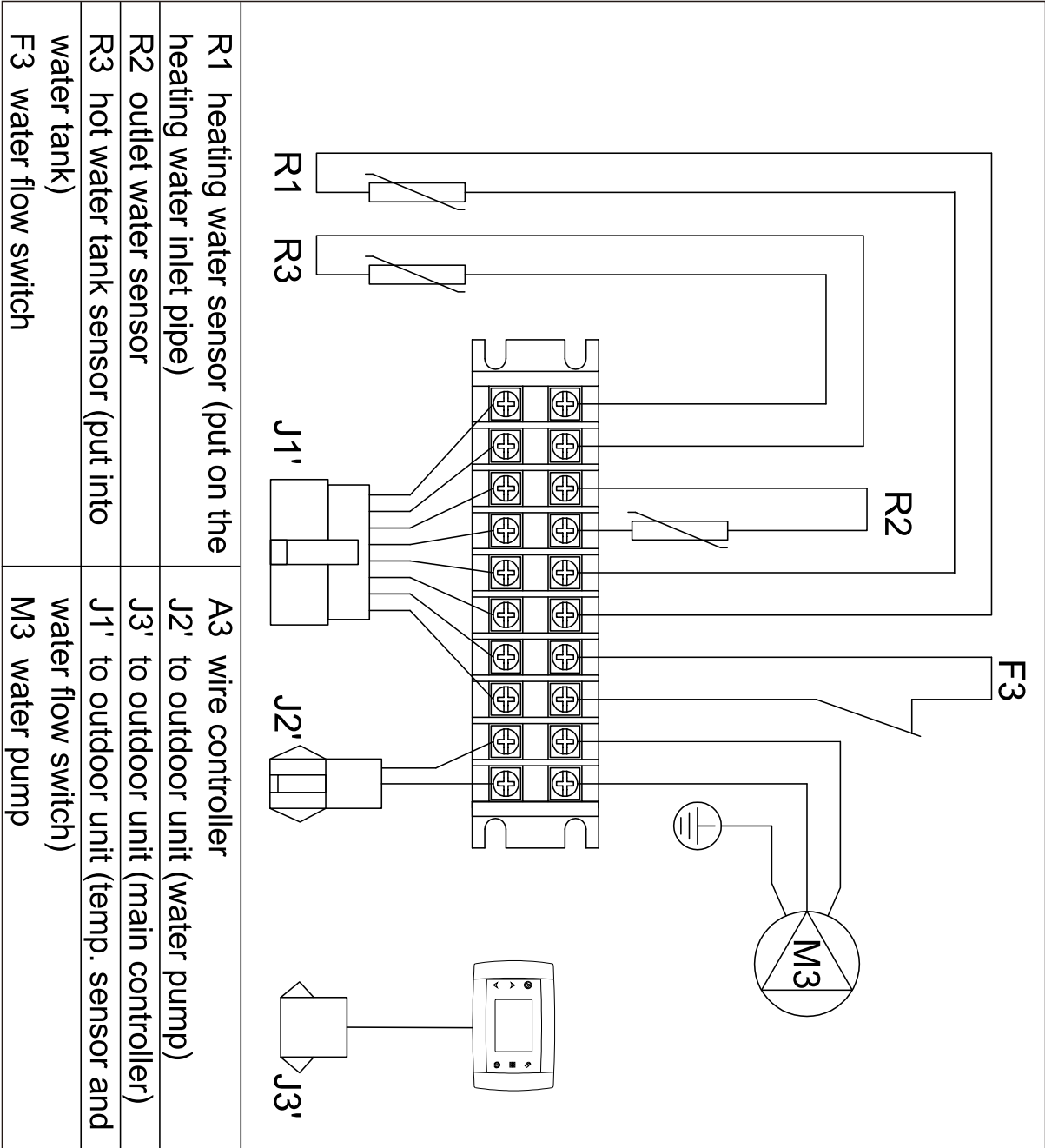

10.Wiring diagram

Outdoor unit

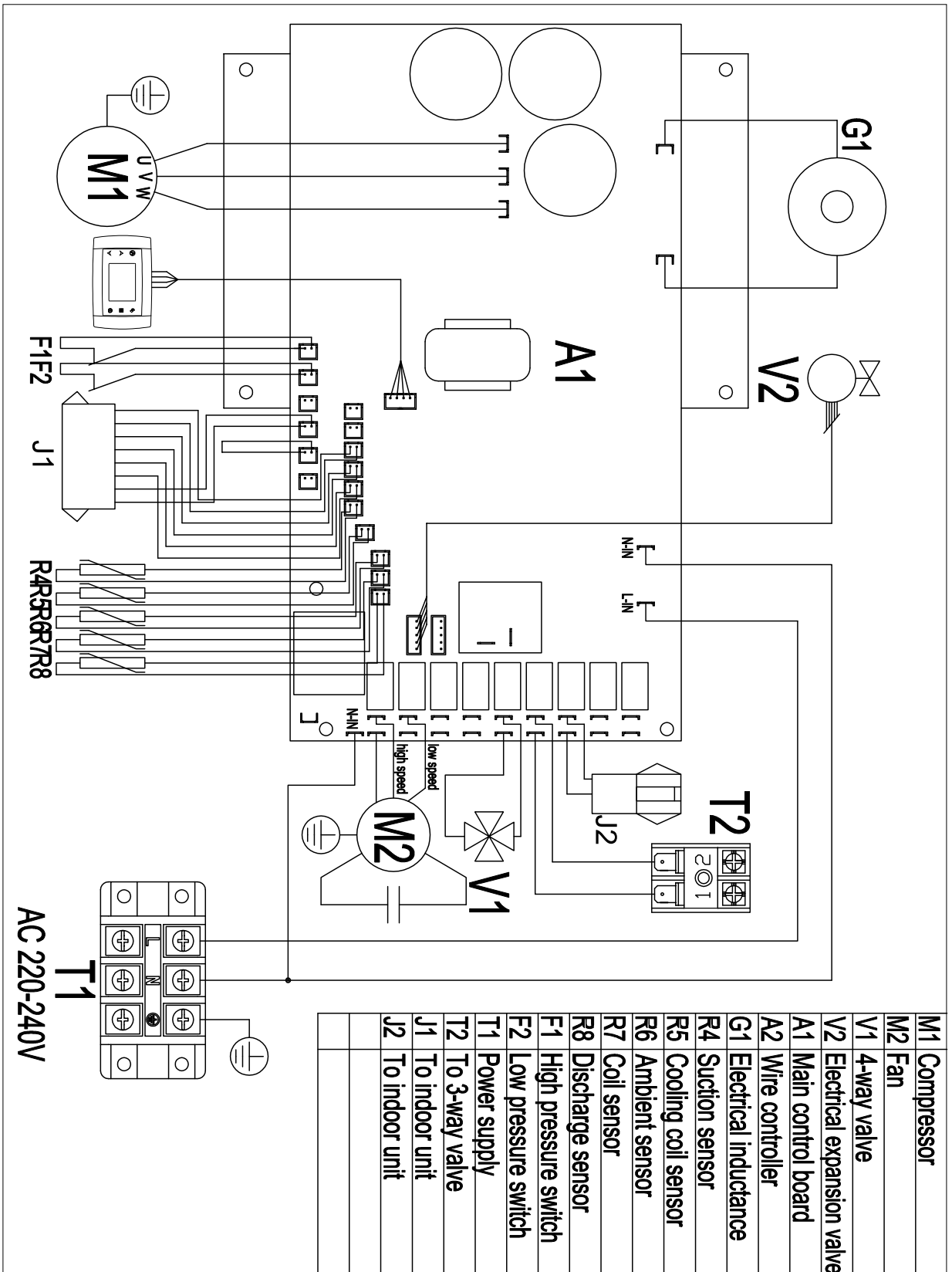

Here is the series number of the heat pump.

Please check above series number whether is the same as the heat pump,
and always provide the series number if you ask for help from retailer.

A large, empty rectangular box with a thin black border, intended for the user to enter the series number of the heat pump.