

- IT *BRUCIATORI DI GASOLIO*
- EN *OIL BURNERS*
- FR *BRULEURS A MAZOUT*
- ES *QUEMADOR DE GASOLEO*
- RU *ДИЗЕЛЬНЫЕ ГОРЕЛКИ*

Ecoflam



MAIOR P 45 AB
MAIOR P 60 AB
MAIOR P 80 AB
MAIOR P120 AB

MOTORIDUTTORE
AIR DAMPER MOTOR
SERVOMOTEUR
MOTORREDUCTOR



420010243500

420010243500

19.10.2009

CARATTERISTICHE TECNICHE

MODELLO		MAIOR P 45	MAIOR P 60	MAIOR P 80	MAIOR P 120
Portata termica max.	kcal/h	459.000	600.000	800.000	1.200.000
	kW	532	710	949	1423
Portata termica min.	kcal/h	255.000	350.000	400.000	700.000
	kW	296	415	474	830
Max. portata gasolio	kg/h	45	60	80	120
Min. portata gasolio	kg/h	25	35	40	70
Tensione alimentazione	50 Hz V	230/400	230/400	230/400	230/400
Potenza motore	kW	0,55	0,74	1,1	2,2
Giri-minuto	N°	2.800	2.800	2.800	2.800
Trasformatore di accensione	kV/mA	10/20	10/20	10/20	10/20
App. controllo fiamma	LANDIS	LMO 44	LMO 44	LMO 44	LMO 44
Combustibile : gasolio	kcal/kg	10.200 max. visc 1,5°E a 20°C			

CURVE DI LAVORO

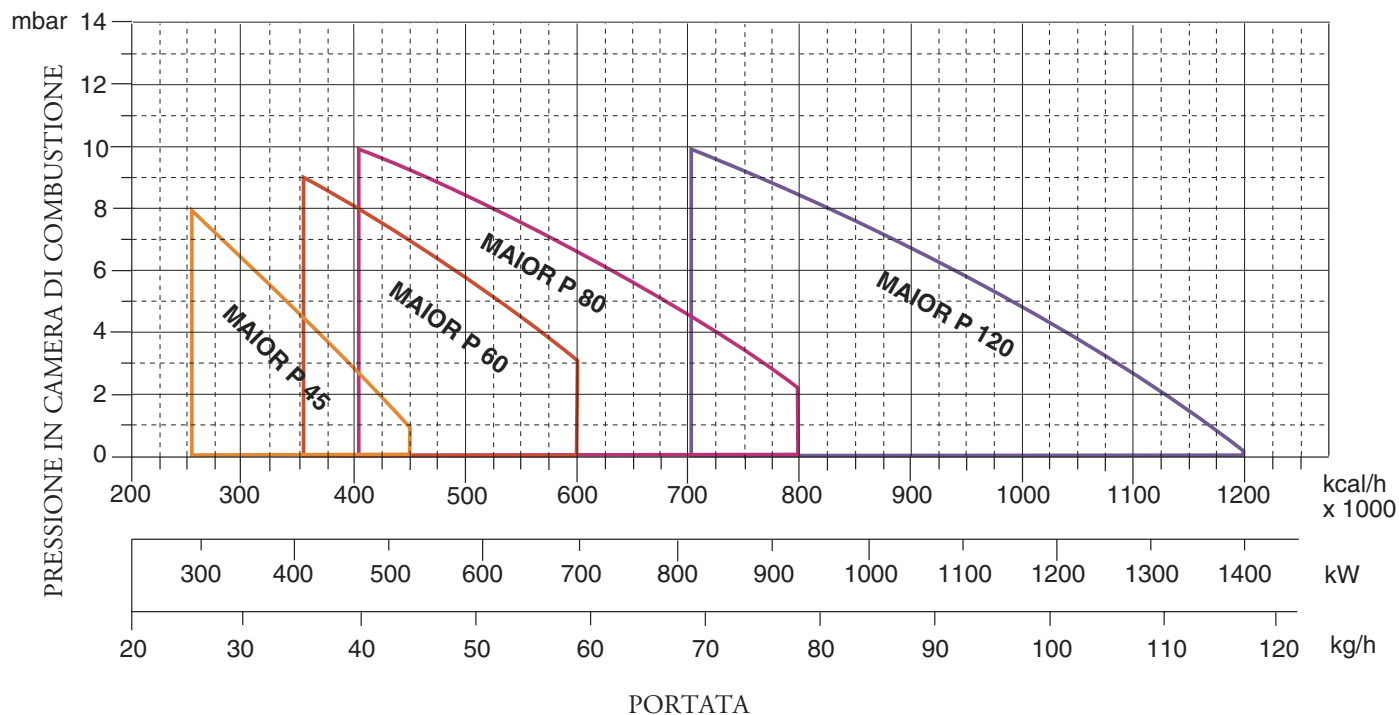

DIMENSIONI DI INGOMBRO

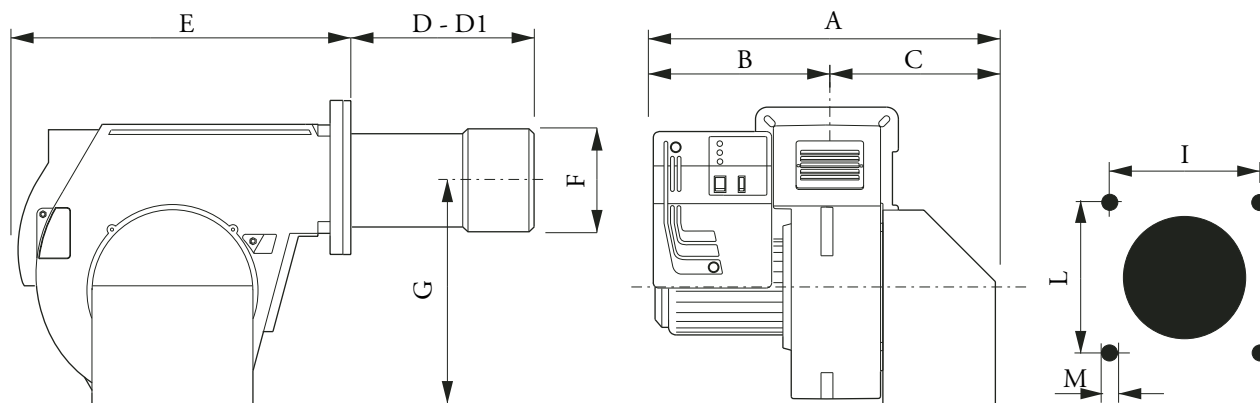

MODELLO	A	B	C	D	D1	E	F	G	I	L	M
MAIOR P 45 AB	590	330	260	225	385	555	160	376	190	190	M10
MAIOR P 60 AB	590	330	260	230	390	555	180	376	190	190	M10
MAIOR P 80 AB	590	330	260	230	390	555	180	376	190	190	M10
MAIOR P 120 AB	690	350	340	220	440	555	190	376	190	190	M10

D = testa corta D1 = testa lunga

INSTALLAZIONE DEL BRUCIATORE

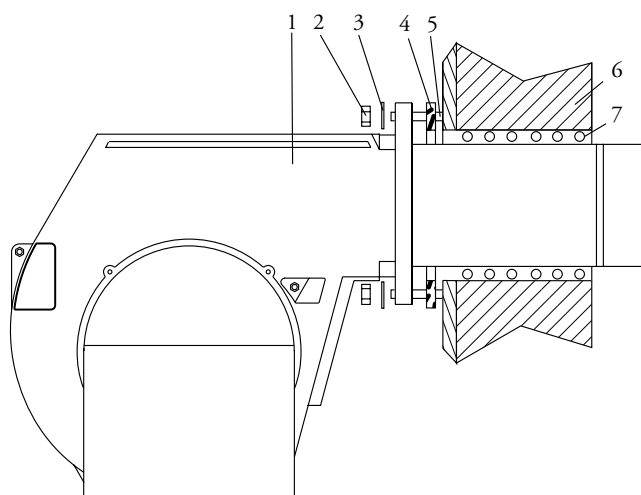

- 1 - BRUCIATORE
- 2 - DADO
- 3 - RONDELLA
- 4 - GUARNIZIONE ISOMART
- 5 - PRIGIONIERO
- 6 - CALDAIA
- 7 - MATERIALE DI RIEMPIMENTO

CIRCUITO IDRAULICO

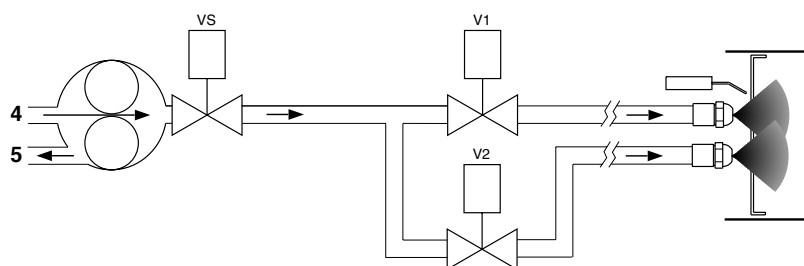
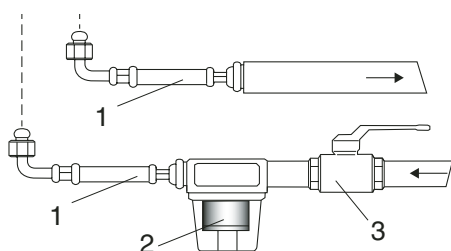

- 1 - FLESSIBILI
- 2 - FILTRO
- 3 - RUBINETTO
- 4 - ASPIRAZIONE
- 5 - RITORNO

ALIMENTAZIONE COMBUSTIBILE

Bitubo dalla sommità del serbatoio

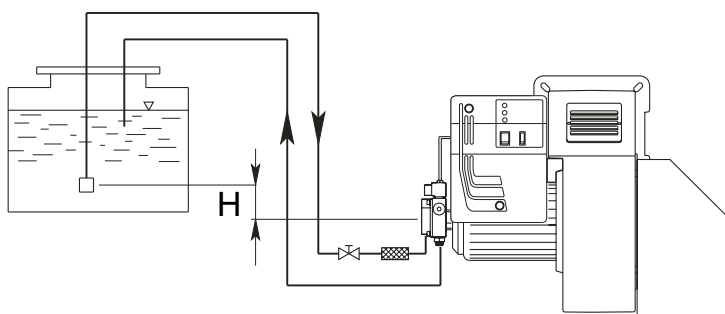

H (m)	Lunghezza tubazioni			
	AS 67 / AN 77 (m)		AJ 6 (m)	
	ø 10 mm	ø 12 mm	ø 14 mm	ø 16 mm
0	32	90	22	38
0,5	36	90	25	45
1	40	90	30	50
2	48	90	35	60
3	56	90	38	70
3,5	60	90	40	80

Bitubo in aspirazione

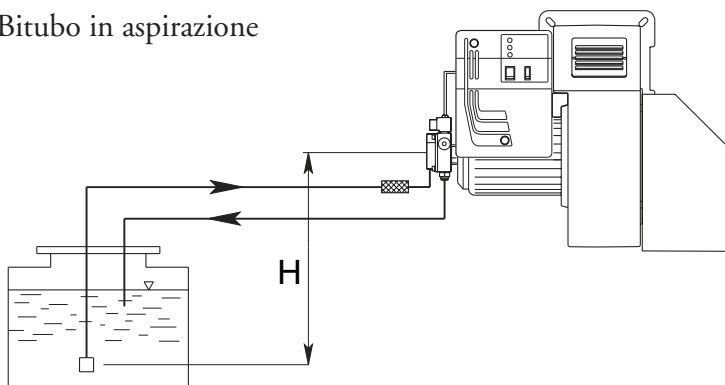

H (m)	Lunghezza tubazioni			
	AS 67 / AN 77 (m)		AJ 6 (m)	
	ø 10 mm	ø 12 mm	ø 14 mm	ø 16 mm
0	25	70	25	45
0,5	21	62	20	38
1	18	54	18	33
2	10	38	10	20
3	5	20	5	10
3,5	---	10	2	4

La lunghezza corretta delle tubazioni è data dalla somma di tutti i tratti rettilinei orizzontali, verticali e delle curve. L'altezza statica di aspirazione è (max. 3.5m) data dalla distanza tra la valvola di fondo e l'asse della pompa del bruciatore. La depressione non deve superare 0,45 bar; un valore maggiore potrebbe causare un deterioramento della pompa con conseguente aumento dei rumori meccanici ed eventuale rottura.

PORTATA UGELLI

DELAVAN B - MONARCH PLP

UGELLO GPH	PRESSIONE POMPA (bar)						
	10	11	12	13	14	15	16
2,50	9,50	9,97	10,41	10,83	11,24	11,64	12,02
3,00	11,40	11,96	12,49	13,00	13,49	13,96	14,42
3,50	13,30	13,95	14,57	15,17	15,74	16,29	16,83
4,00	15,20	15,94	16,65	17,33	17,99	18,62	19,23
4,50	17,10	17,94	18,73	19,50	20,24	20,95	21,63
5,00	19,00	19,93	20,82	21,67	22,48	23,27	24,04
5,50	20,90	21,92	22,90	23,83	24,73	25,60	26,44
6,00	22,80	23,92	24,98	26,00	26,98	27,93	28,84
6,50	23,70	25,91	27,06	28,17	29,23	30,26	31,25
7,00	26,60	27,90	29,14	30,33	31,48	32,58	33,65
7,50	28,50	29,90	31,22	32,50	33,73	34,91	36,05
8,30	31,54	33,08	34,55	35,97	37,32	38,63	39,90
9,50	36,10	37,87	39,55	41,17	42,72	44,22	45,67
10,50	40,06	41,73	43,74	45,41	47,20	48,90	50,50
12,00	45,60	47,80	50,00	52,00	54,00	55,90	57,70
13,80	52,40	55,00	57,50	59,80	62,10	64,20	66,30
15,30	58,10	61,00	63,70	66,30	68,80	71,10	73,60
17,50	66,50	69,80	72,90	75,80	78,70	81,50	84,10
19,50	74,10	77,70	81,20	84,50	87,70	90,80	93,70
21,50	81,70	85,70	89,50	93,20	96,70	100,10	103,40
24,00	91,20	95,70	99,90	104,00	107,90	111,70	115,40
GPH	PORTATA kg/h						

PULIZIA E SOSTITUZIONE DELL'UGELLO

Utilizzare solo la apposita chiave fornita in dotazione pre rimuovere l'ugello, facendo attenzione a non danneggiare gli elettrodi. Montare il nuovo ugello con la medesima cura.

N.B.: Verificare sempre la posizione degli elettrodi dopo il montaggio dell'ugello (vedi figura). Una posizione errata può comportare problemi di accensione.

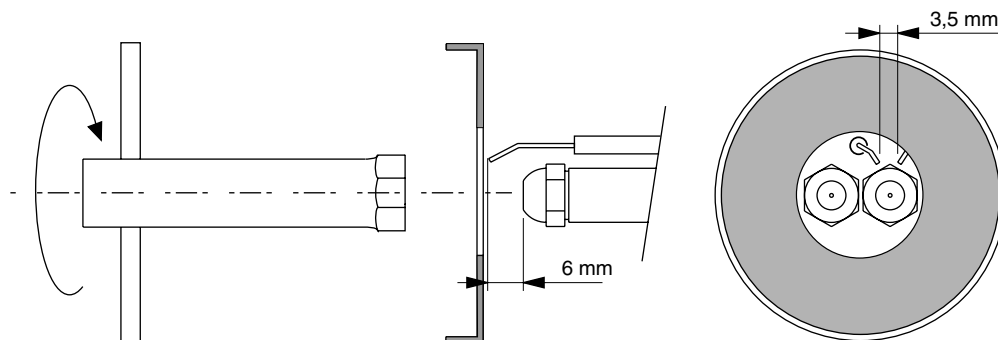

INNESCO E REGOLAZIONE DELLA POMPA GASOLIO

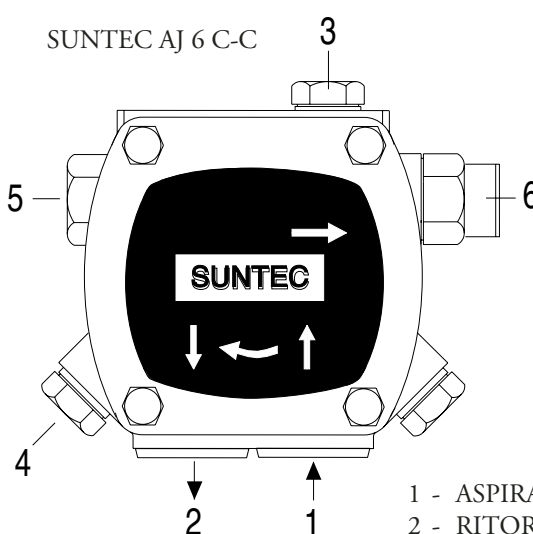
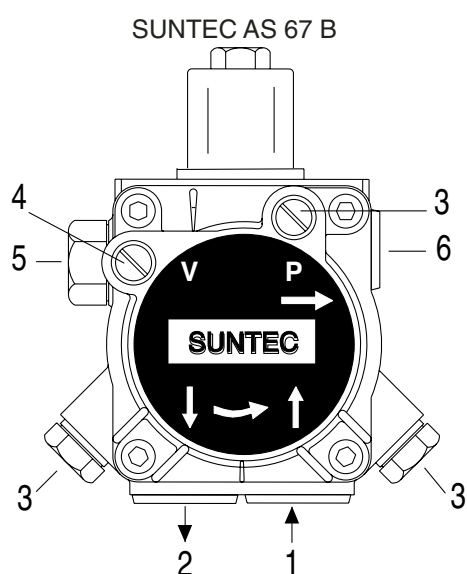

SUNTEC AN 77

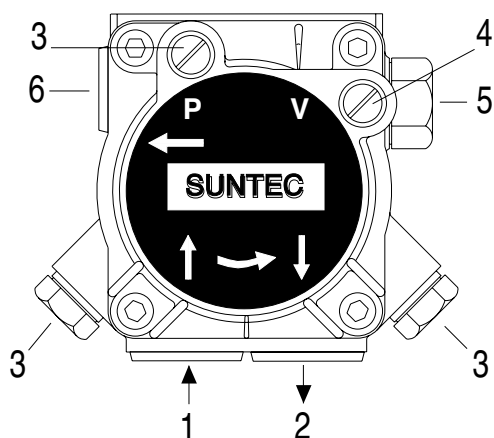

- 1 - ASPIRAZIONE
- 2 - RITORNO
- 3 - SFIATO E PRESA MANOMETRO
- 4 - PRESA VUOTOMETRO
- 5 - REGOLAZIONE PRESSIONE
- 6 - ALL' UGELLO

CONTROLLARE:

- Che le tubazioni siano perfettamente a tenuta;
- Che siano usati tubi rigidi (preferibilmente di rame), ove possibile;
- Che la depressione in aspirazione non ecceda 0,45 bar, per evitare che la pompa entri in cavitazione;
- Che la valvola di fondo sia dimensionata correttamente;

La pressione della pompa viene regolata al valore di 12 bar durante il collaudo del bruciatore. Prima di avviare il bruciatore, spurgare l'aria contenuta nella pompa attraverso la presa del manometro. Riempire le tubazioni di gasolio per facilitare l'innescò della pompa. Avviare il bruciatore e verificare la pressione di alimentazione della pompa. Se l'innescò della pompa non dovesse avvenire durante il primo prelavaggio, con conseguente, successiva entrata in blocco del bruciatore, riarmarne il blocco per riavviarlo, premendo il pulsante rosso sull'apparecchiatura di controllo. Se, ad innescò della pompa avvenuto, il bruciatore dovesse andare in blocco dopo la fase di prelavaggio, a causa di una caduta di pressione del gasolio nella pompa, riarmarne il blocco per riavviarlo. Non permettere che la pompa funzioni per più di tre minuti senza gasolio. Nota: prima di avviare il bruciatore, assicurarsi che il tubo di ritorno sia aperto. Una sua eventuale occlusione provocherebbe una rottura dell'organo di tenuta della pompa.

AVVIAMENTO E REGOLAZIONE DEL BRUCIATORE

Dopo aver eseguito l'installazione del bruciatore, verificare i seguenti punti:

- Tensione di alimentazione del bruciatore ed i fusibili di protezione di rete.
- I collegamenti del motore.
- La corretta lunghezza delle tubazioni e la loro tenuta.
- Il tipo di combustibile, che deve essere adatto al bruciatore.
- Il collegamento dei termostati caldaia e delle varie sicurezze.
- Il senso di rotazione del motore.
- La corretta taratura della protezione termica del motore.

Quando tutte queste condizioni sono verificate e soddisfatte, si può procedere con il collaudo del bruciatore.

Dare tensione al bruciatore. L'apparecchiatura di controllo alimenterà, allo stesso tempo, sia il trasformatore di accensione che il motore del bruciatore, che provvederà ad effettuare un prelavaggio della camera di combustione per un periodo di 20 secondi circa. Al termine del prelavaggio, l'apparecchiatura di controllo apre le elettrovalvole della pompa gasolio e quella del 1° stadio (Bassa fiamma), il trasformatore d'accensione produce una scintilla ed il bruciatore si accende. Dopo l'intervallo di sicurezza di 5 secondi, ad accensione avvenuta, l'apparecchiatura di controllo disinserisce il trasformatore di accensione quindi, dopo altri 10 secondi, aziona il servocomando dell'aria alla massima apertura ed apre l'elettrovalvola del 2° stadio (Alta fiamma).

In caso di accensione difettosa, l'apparecchiatura di controllo causa il blocco del bruciatore entro 5 secondi.

In questo caso, il riarmo manuale del bruciatore non potrà avvenire prima che siano trascorsi 30 secondi dall'entrata in blocco. Per avere una combustione ottimale, occorrerà regolare la portata dell'aria in ALTA e BASSA fiamma, seguendo le istruzioni fornite più avanti. Durante tale fase, si potrà passare manualmente dalla posizione ALTA fiamma (II) a quella di BASSA fiamma (I), e viceversa, tramite l'interruttore di ALTA/BASSA fiamma. Al termine delle regolazioni, lasciare l'Interruttore in posizione II (Alta fiamma).

La pressione di alimentazione della pompa gasolio dovrà aggirarsi sui 12 bar.

SOLO PER APPARECCHIATURA LANDIS LMO 44

In caso di blocco é disponibile l'indicazione della causa che ha provocato il blocco. Operare come segue: con l'apparecchiatura in blocco (led rosso acceso) tenere premuto il pulsante di sblocco per più 3 secondi, quindi rilasciarlo. Il led rosso inizierà a lampeggiare indicando la causa secondo la seguente tabella:

Codice errore	Possibile causa
2 lampeggi	Assenza di fiamma al termine del tempo di sicurezza all'accensione «TSA» - elettrovalvole difettose - rilevatore fiamma difettoso - regolazione bruciatore errata - elettrodi difettosi
3 lampeggi	Non utilizzati
4 lampeggi	Luci estranee durante la fase di pre-ventilazione
5 lampeggi	Non utilizzati
6 lampeggi	Non utilizzati
7 lampeggi	Troppe mancanze di fiamma durante il funzionamento (superato il limite del n° di ripetizioni del ciclo) - elettrovalvole difettose - rilevatore fiamma difettoso - regolazione bruciatore errata
8 lampeggi	Controllo del tempo riscaldamento combustibile
9 lampeggi	Non utilizzati
10 lampeggi	Contatti in uscita difettosi o guasto del dispositivo interno

REGOLAZIONE TESTA DI COMBUSTIONE

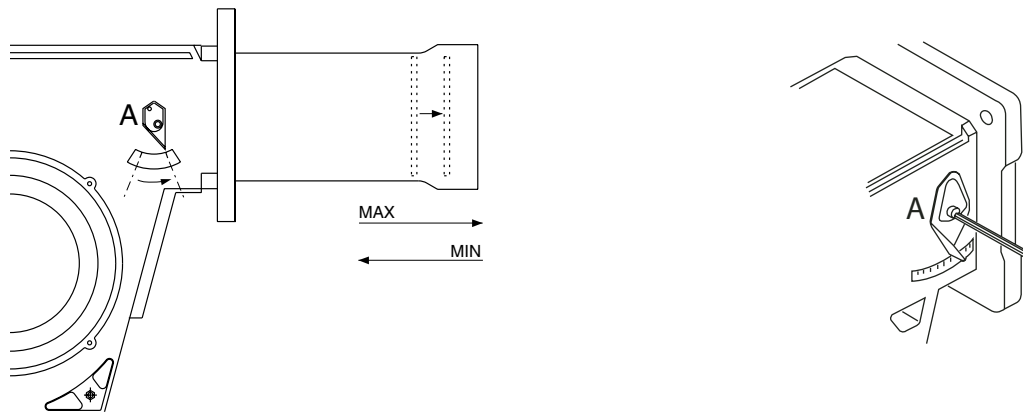

REGOLAZIONE DELLA PORTATA DELL'ARIA DI COMBUSTIONE (ALTA-BASSA FIAMMA)

LANDIS SQN 30-31 121A2700



Togliere il coperchio per accedere alle camme di regolazione. Lo spostamento delle camme va effettuato con l'ausilio dell'apposita chiavetta in dotazione. Descrizione :

- I - Camma di regolazione posizione di apertura in 2° fiamma (potenza max.)
- II - Camma di regolazione della posizione serranda allo spegnimento (chiusura)
- III - Camma di regolazione posizione di apertura in 1° fiamma (potenza min.)
- IV - Camma non utilizzata.
- V - Camma di consenso all'apertura dell'elettrovalvola del 2° stadio.

NOTA : la camma V (di consenso all'apertura dell'elettrovalvola del 2° stadio) va regolata in una posizione intermedia tra quella di 1°fiamma e quella di 2°fiamma(ad un angolo di circa 5° superiore a quello della posizione di 1° fiamma).

COLLEGAMENTI ELETTRICI

Tutti i bruciatori vengono collaudati a 400V - 50Hz trifase per i motori, e 230V - 50Hz monofase con neutro per le apparecchiature ausiliarie. Se si rendesse necessario alimentare il bruciatore con 230V - 50Hz trifase senza neutro, modificare i collegamenti sul motore e sulla morsettiera come indicato in figura. Proteggere la linea di alimentazione del bruciatore con fusibili adeguati.

TECHNICAL DATA

MODELS		MAIOR P 45	MAIOR P 60	MAIOR P 80	MAIOR P 120
Thermal power max.	kcal/h	459.000	600.000	800.000	1.200.000
	kW	532	710	949	1423
Thermal power min.	kcal/h	255.000	350.000	400.000	700.000
	kW	296	415	474	830
Max. flow rate light oil	kg/h	45	60	80	120
Min. flow rate light oil	kg/h	25	35	40	70
Feeding power	50 Hz V	230/400	230/400	230/400	230/400
Motor	kW	0,55	0,74	1,1	2,2
Rpm	Nº	2.800	2.800	2.800	2.800
Ignition transformer	kV/mA	10/20	10/20	10/20	10/20
Control box	LANDIS	LMO 44	LMO 44	LMO 44	LMO 44
Fuel : light oil	kcal/kg	10.200 max. visc 1,5°E a 20°C			

WORKING FIELDS

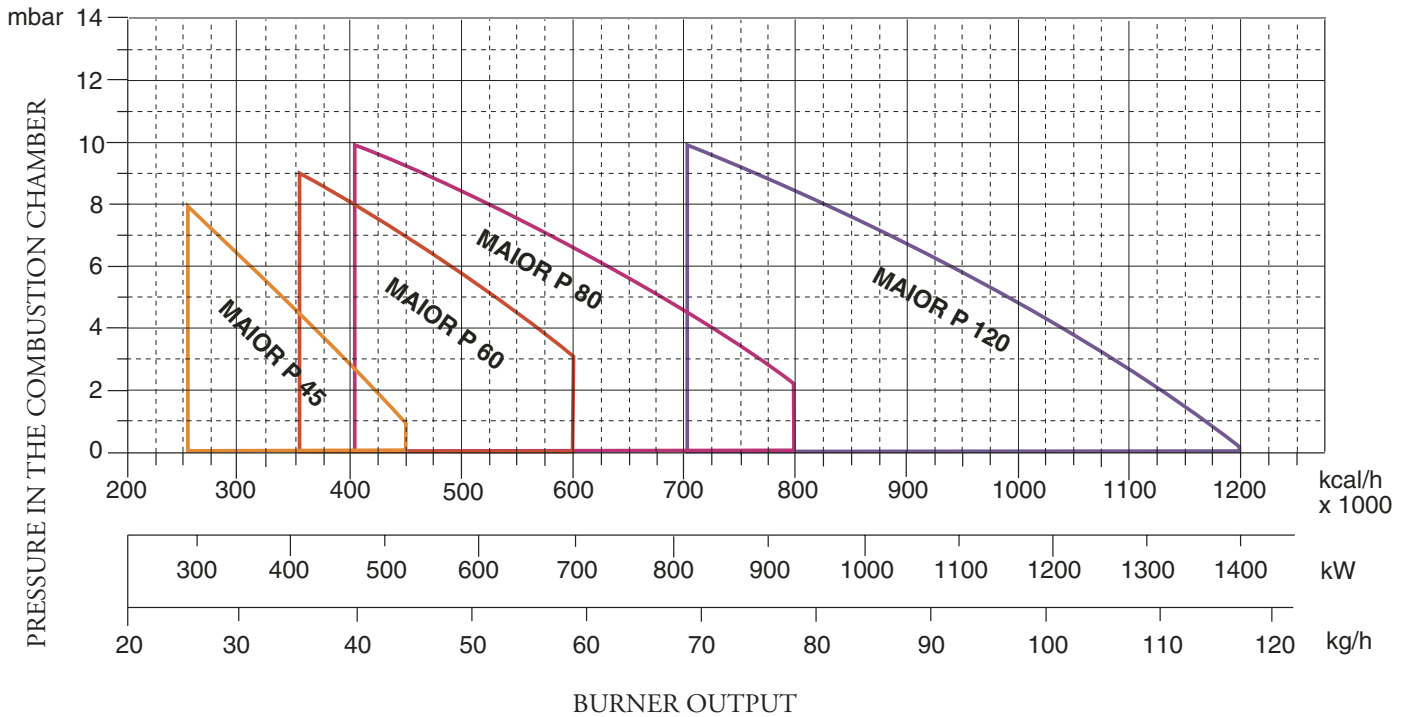

OVERALL DIMENSIONS

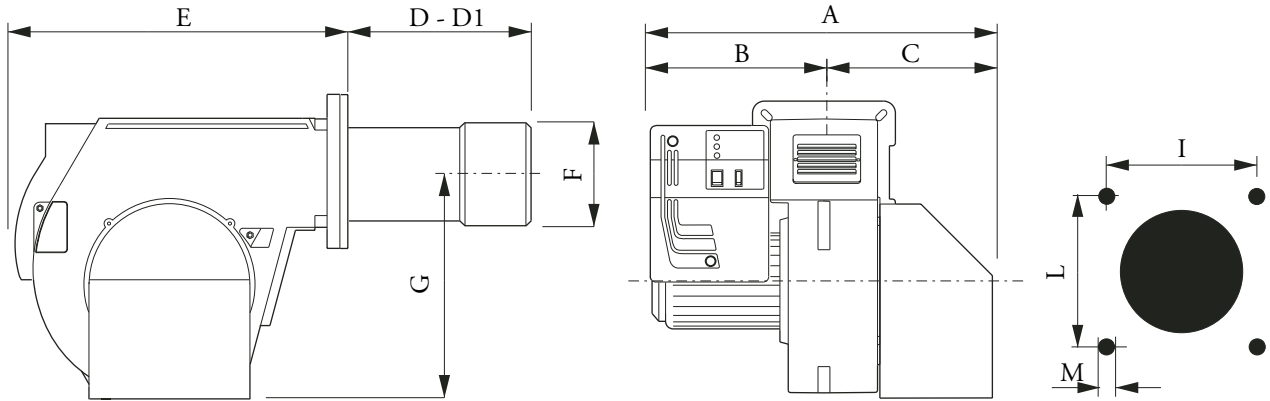

MODELS	A	B	C	D	D1	E	F	G	I	L	M
MAIOR P 45 AB	590	330	260	225	385	555	160	376	190	190	M10
MAIOR P 60 AB	590	330	260	230	390	555	180	376	190	190	M10
MAIOR P 80 AB	590	330	260	230	390	555	180	376	190	190	M10
MAIOR P 120 AB	690	350	340	220	440	555	190	376	190	190	M10

D = short head D1 = long head

BURNER INSTALLATION

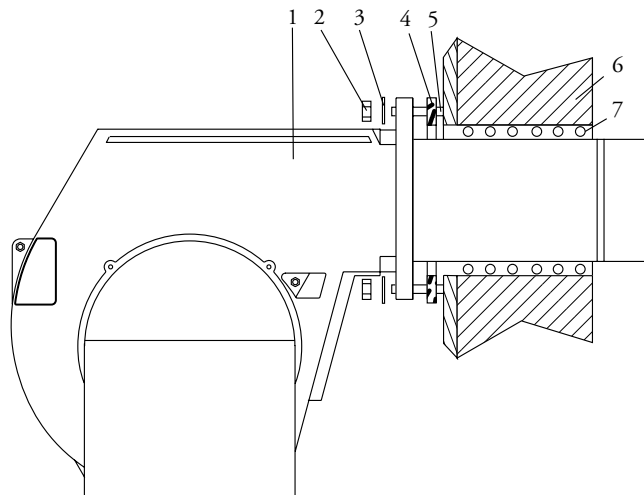

- 1 - BURNER
- 2 - NUT
- 3 - WASHER
- 4 - GASKET
- 5 - BOLT
- 6 - BOILER
- 7 - GASKET

HYDRAULIC CIRCUIT

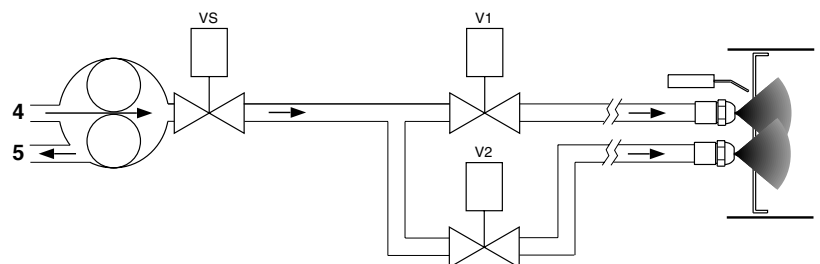
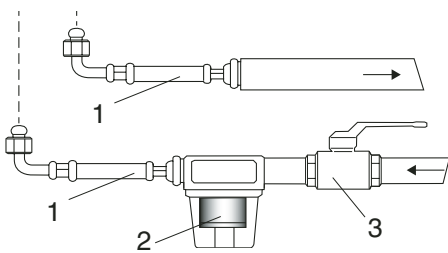

- 1 - HOSE
- 2 - OIL FILTER
- 3 - OIL COCK
- 4 - SUCTION
- 5 - RETURN

MAXIMUM LENGTH OF SUCTION LINES FOR TWO-PIPE SYSTEM

Two-pipe siphon feed system

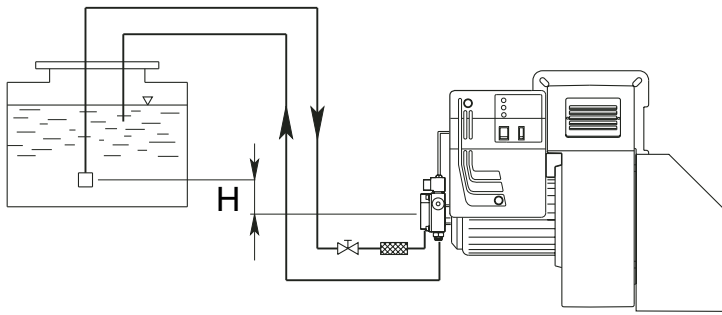

H (m)	Pipe length			
	AS 67 / AN 77 (m)		AJ 6 (m)	
	ø 10 mm	ø 12 mm	ø 14 mm	ø 16 mm
0	32	90	22	38
0,5	36	90	25	45
1	40	90	30	50
2	48	90	35	60
3	56	90	38	70
3,5	60	90	40	80

Two-pipe lift system

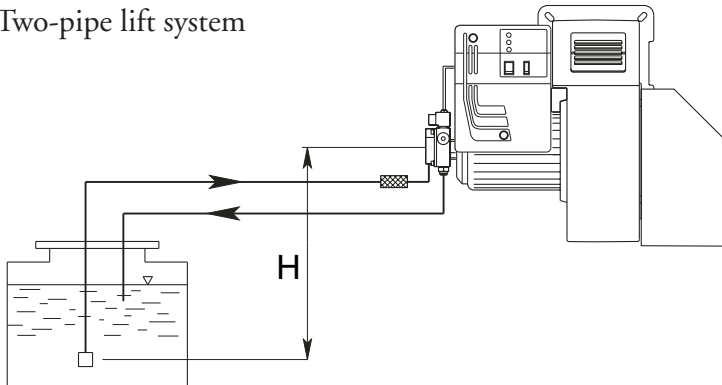

H (m)	Pipe length			
	AS 67 / AN 77 (m)		AJ 6 (m)	
	ø 10 mm	ø 12 mm	ø 14 mm	ø 16 mm
0	25	70	25	45
0,5	21	62	20	38
1	18	54	18	33
2	10	38	10	20
3	5	20	5	10
3,5	---	10	2	4

To correct length of pipes is calculated by summing up the length of all vertical and horizontal right sections and bends. The static suction head will be the distance between the non-return valve and the burner's pump axle. The depression must not be greater than 0.45 bar; should it be higher, some damages could occur to the pump, with consequent increase in mechanical noises and ,eventually, a failure.

NOZZLE FLOW RATE
DELAVAN B - MONARCH PLP

NOZZLE GPH	PUMP PRESSURE (bar)						
	10	11	12	13	14	15	16
2,50	9,50	9,97	10,41	10,83	11,24	11,64	12,02
3,00	11,40	11,96	12,49	13,00	13,49	13,96	14,42
3,50	13,30	13,95	14,57	15,17	15,74	16,29	16,83
4,00	15,20	15,94	16,65	17,33	17,99	18,62	19,23
4,50	17,10	17,94	18,73	19,50	20,24	20,95	21,63
5,00	19,00	19,93	20,82	21,67	22,48	23,27	24,04
5,50	20,90	21,92	22,90	23,83	24,73	25,60	26,44
6,00	22,80	23,92	24,98	26,00	26,98	27,93	28,84
6,50	23,70	25,91	27,06	28,17	29,23	30,26	31,25
7,00	26,60	27,90	29,14	30,33	31,48	32,58	33,65
7,50	28,50	29,90	31,22	32,50	33,73	34,91	36,05
8,30	31,54	33,08	34,55	35,97	37,32	38,63	39,90
9,50	36,10	37,87	39,55	41,17	42,72	44,22	45,67
10,50	40,06	41,73	43,74	45,41	47,20	48,90	50,50
12,00	45,60	47,80	50,00	52,00	54,00	55,90	57,70
13,80	52,40	55,00	57,50	59,80	62,10	64,20	66,30
15,30	58,10	61,00	63,70	66,30	68,80	71,10	73,60
17,50	66,50	69,80	72,90	75,80	78,70	81,50	84,10
19,50	74,10	77,70	81,20	84,50	87,70	90,80	93,70
21,50	81,70	85,70	89,50	93,20	96,70	100,10	103,40
24,00	91,20	95,70	99,90	104,00	107,90	111,70	115,40
GPH	OUTPUT kg/h						

NOZZLE CLEANING AND REPLACEMENT

Use only the suitable box wrench provided for this operation to remove the nozzle, taking care to not damage the electrodes. Fit the new nozzle with the same care.

Note: Always check the position of electrodes after having replaced the nozzle (see illustration). A wrong position could cause ignition troubles.

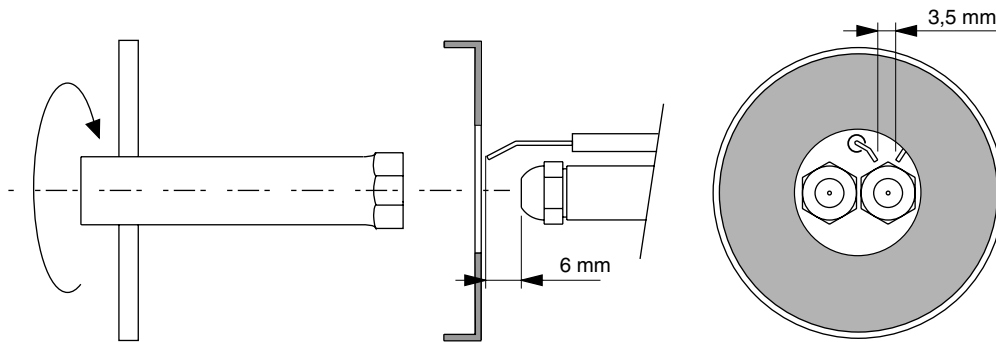

PRIMING AND ADJUSTMENT OF OIL PUMP

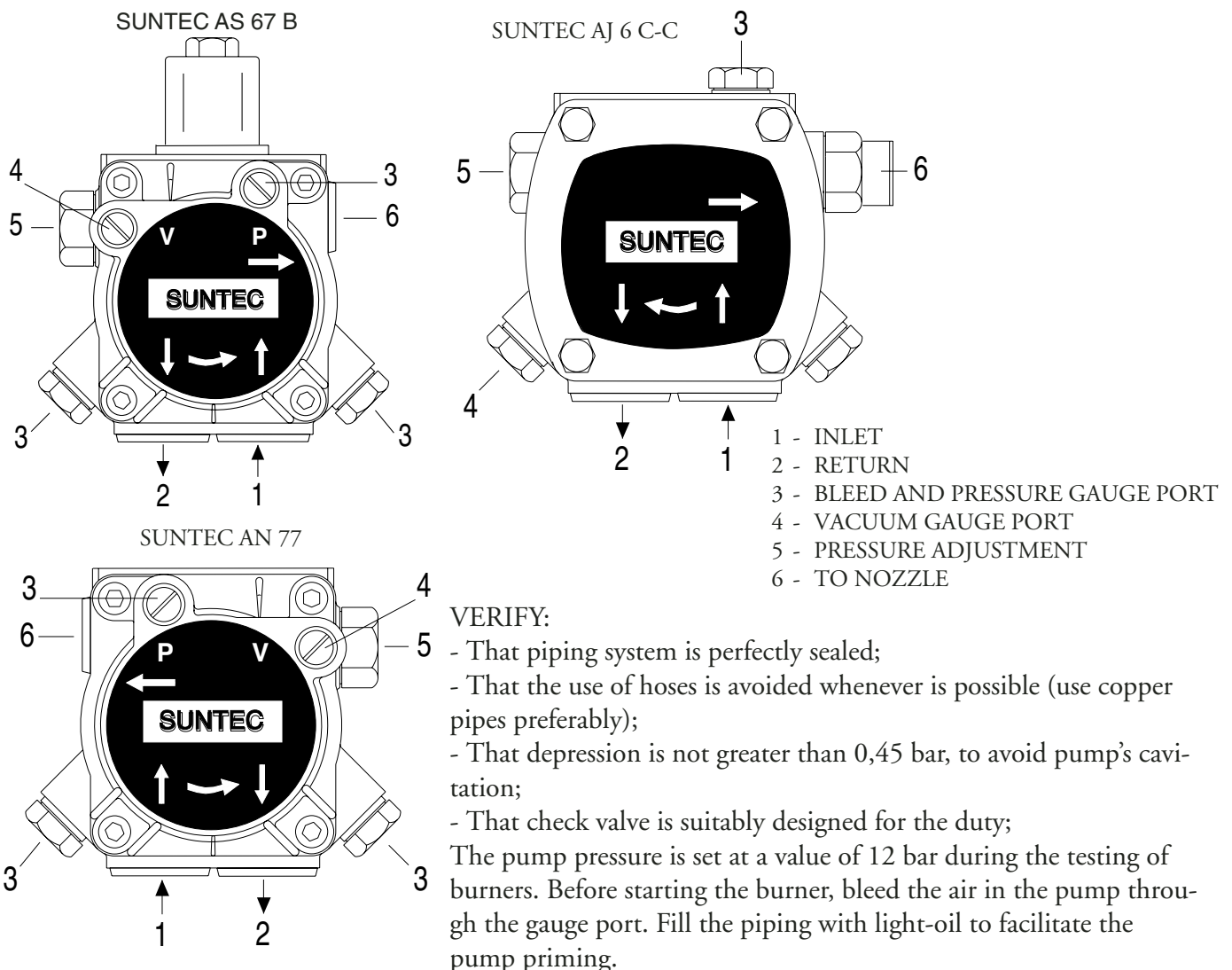

Start the burner and check the pump feeding pressure. In case the pump priming does not take place during the first prepurging, with a consequent, subsequent lock-out of the burner, rearm the burner's lock-out to restart, by pushing the button on the control box. If, after a successful pump priming, the burner locks-out after the prepurging, due to a fuel pressure drop in the pump, rearm the burner's lock-out to restart the burner. Do never allow the pump working without oil for more than three minutes. Note: before starting the burner, check that the return pipe is open. An eventual obstruction could damage the pump sealing device.

BURNER START-UP AND ADJUSTMENT

Once having installed the burner, check the following items:

- The burner power feeding and the main line protection fuses
- The correct length of pipes and that the same are sealed.
- The type of fuel, which must be suitable for burner.
- The connection of boiler's thermostats and all the safeties.
- The motor rotation direction.
- The correct calibration of the motor's thermal protection.

When all the above mentioned conditions are checked and accomplished, it is possible to go on with burner's tests. Power the burner. The control box feeds the ignition transformer and the burner's motor at the same time, which will run a prepurging of the combustion chamber for about 20 sec.

At the end of prepurging, the control box opens the fuel pump and the 1st stage (Low flame) solenoid valves, the ignition transformer produces a spark and the burner ignites. After a safety interval of 5 seconds and a correct ignition, the control box turns off the ignition transformer and, 10 seconds later, sets the motorised air damper to its maximum opening and opens the 2nd stage solenoid valve (High flame). In case of faulty ignition, the control box switches the burner into safety condition. In such a case, the manual rearming of the burner shall not take place before 30 seconds have elapsed from the burner's safety shutdown. In order to obtain an optimal combustion, it is necessary adjust the LOW - HIGH flame air flow, according to the instruction given further on. During such a phase, it will be possible to manually switch between HIGH (II) and LOW (I) flame and viceversa, through the High/Low flame switch. At the end of the adjusting phase, leave the switch in position II (HIGH flame).

The fuel pump feeding pressure, must remain around 12 bar.

LANDIS LMO 44 CONTROL INFORMATION SYSTEM

In case of burner lockout, it is possible to read which cause originated it. Proceed as follows: with the burner in lockout mode (red LED switched on) keep pressed the lockout button for more than 3 sec. then release it. The red LED will blink according to the following error code list:

Error Code	Possible cause
2 blinks	No establishment of flame at the end of «TSA» - Faulty or soiled fuel valves - Faulty or soiled flame detector - Poor adjustment of burner, no fuel - Faulty ignition
3 blinks	Free
4 blinks	Extraneous light on burner start-up
5 blinks	Free
6 blinks	Free
7 blinks	Too many losses of flame during operation (limitation of the number of repetitions) - Faulty or soiled fuel valves - Faulty or soiled flame detector - Poor adjustment of burner
8 blinks	Time supervision oil pre-heater
9 blinks	Free
10 blinks	Wiring error or internal error, output contacts

FIRING HEAD SETTING

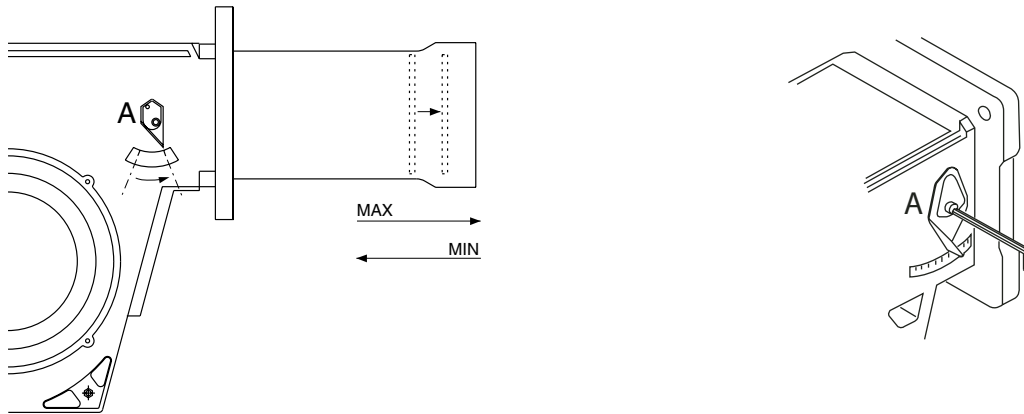

COMBUSTION AIR FLOW ADJUSTMENT (HIGH-LOW FLAME)

LANDIS SQN 30-31 121A2700



Remove the cover to gain access to the adjustment cams. The cams are adjusted using the key provided for description:

- I - Limit switch for the "HIGH FLAME" position of the air damper (MAX POWER).
- II - Adjusting cam for the air damper position at shut down.
- III - Limit switch for the "LOW FLAME" position of the air damper.
- IV - Limit switch "NOT USED"
- V - Auxiliary switch for the release of the second stage valve (HIGH FLAME).

NOTE : Cam V (to enable the stage two electrovalve to open) is adjusted to an intermediate position between the low flame and high flame positions (to an angle approximately 5° greater than the low flame position).

ELECTRICAL CONNECTIONS

All burners are factory tested at 400V - 50Hz 3-phase for motors, and 230V - 50Hz single phase with neutral for auxiliary equipments. Should it be necessary to power the burner with 230V - 50Hz, modify the connections on motor and the terminal board as shown in the picture. Protect the burner supply line with suitable fuses and/or other safety devices as required by the local regulations on the matter.

FR **CARACTERISTIQUES TECHNIQUES**

MODELES		MAIOR P 45	MAIOR P 60	MAIOR P 80	MAIOR P 120
Puissance thermique max	kcal/h	459.000	600.000	800.000	1.200.000
	kW	532	710	949	1423
Puissance thermique min.	kcal/h	255.000	350.000	400.000	700.000
	kW	296	415	474	830
Débit max.	kg/h	45	60	80	120
Débit min	kg/h	25	35	40	70
Tension d'alimentation	50 Hz V	230/400	230/400	230/400	230/400
Moteur	kW	0,55	0,74	1,1	2,2
Tours par minute	N°	2.800	2.800	2.800	2.800
Transformateur	kV/mA	10/20	10/20	10/20	10/20
Coffret de sécurité	LANDIS	LMO 44	LMO 44	LMO 44	LMO 44
Combustible : mazout	kcal/kg	10.200 max. visc 1,5°E a 20°C			

COURBE DE TRAVAIL

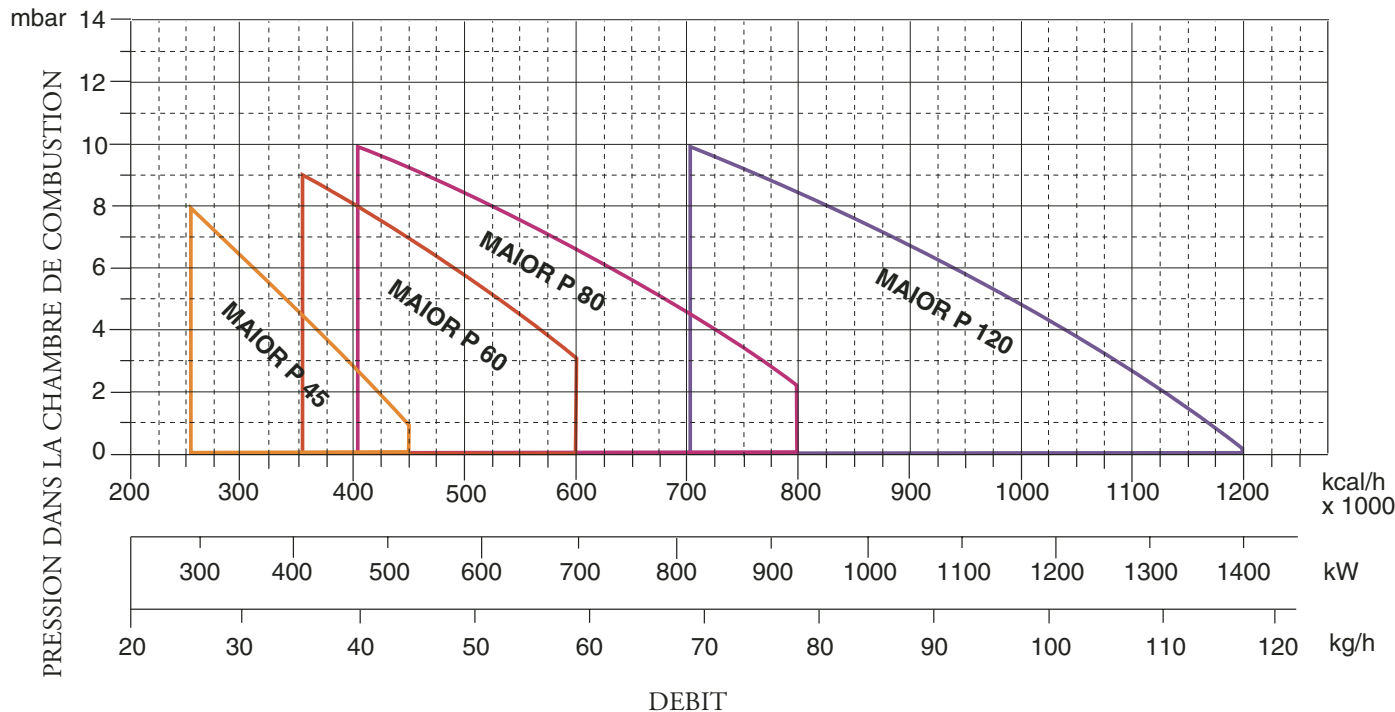

DIMENSIONS D'ENCOMBREMENT

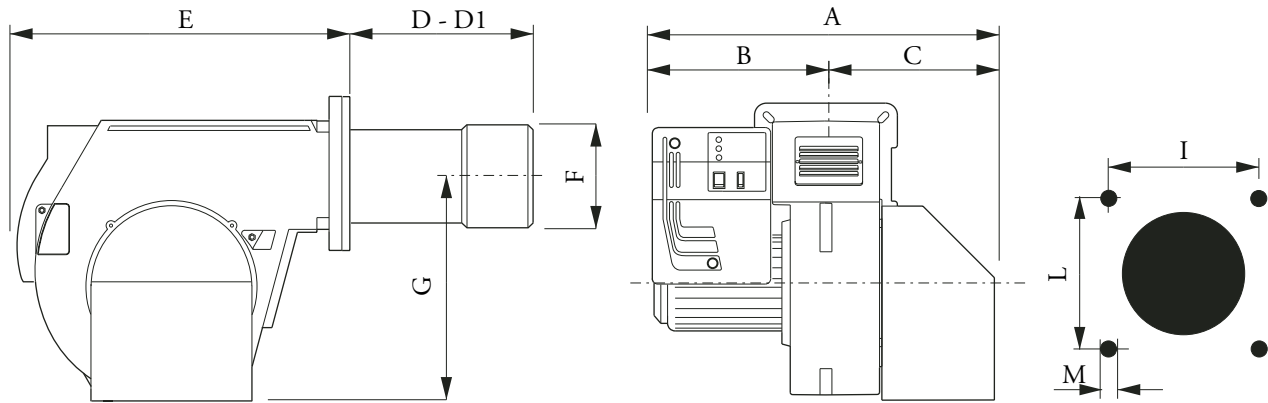

MODELES	A	B	C	D	D1	E	F	G	I	L	M
MAIOR P 45 AB	590	330	260	225	385	555	160	376	190	190	M10
MAIOR P 60 AB	590	330	260	230	390	555	180	376	190	190	M10
MAIOR P 80 AB	590	330	260	230	390	555	180	376	190	190	M10
MAIOR P 120 AB	690	350	340	220	440	555	190	376	190	190	M10

D = tete courte D1 = tete longue

MONTAGE SUR CHAUDIERE

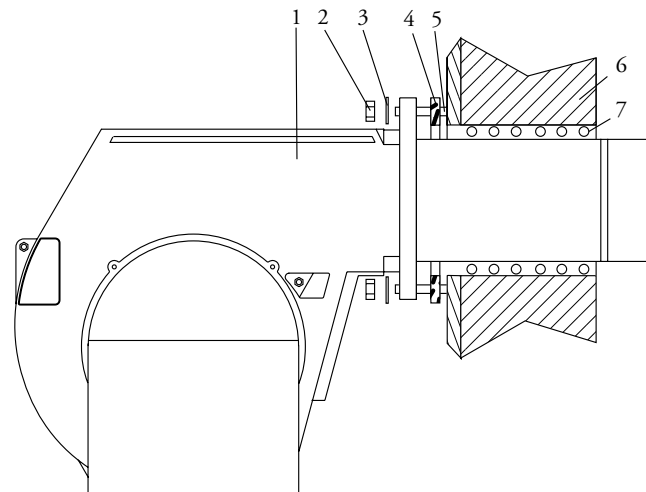

- 1 - BRULEUR
- 2 - ECROU
- 3 - RONDELLE
- 4 - JOINT
- 5 - VIS PRISONNIERS
- 6 - CHAUDIERE
- 7 - CORDON D'ETANCHEITE

CIRCUIT HYDRAULIQUE

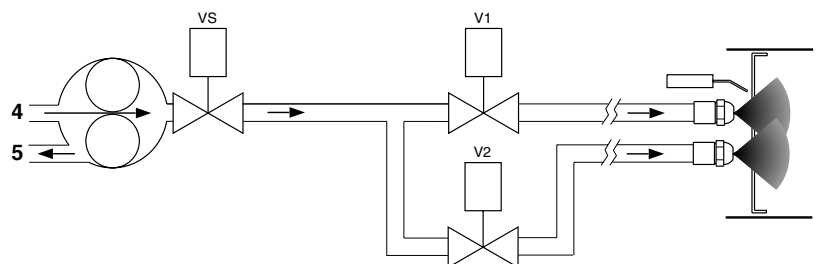
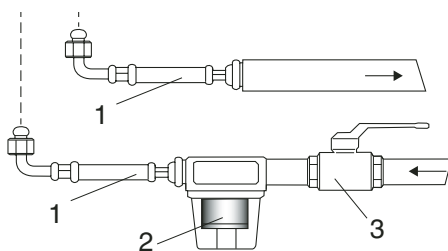

- 1 - FLEXIBLES
- 2 - FILTRE
- 3 - ROBINET D'ARRET
- 4 - ASPIRATION
- 5 - RETOUR

RACCORDEMENT DU CIRCUIT D'ALIMENTATION FOD

FR

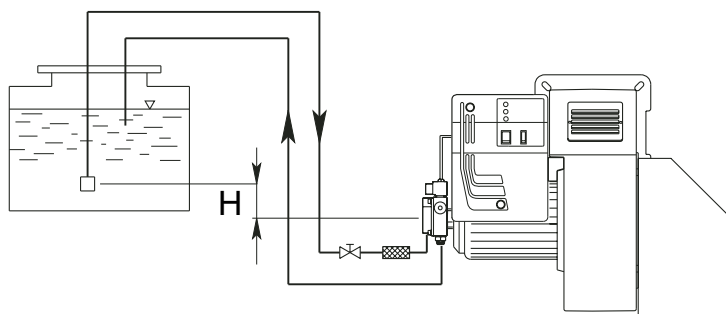
Raccordement bitube en charge

H (m)	Longueur tuyaux en mètres			
	AS 67 / AN 77 (m)		AJ 6 (m)	
	ø 10 mm	ø 12 mm	ø 14 mm	ø 16 mm
0	32	90	22	38
0,5	36	90	25	45
1	40	90	30	50
2	48	90	35	60
3	56	90	38	70
3,5	60	90	40	80

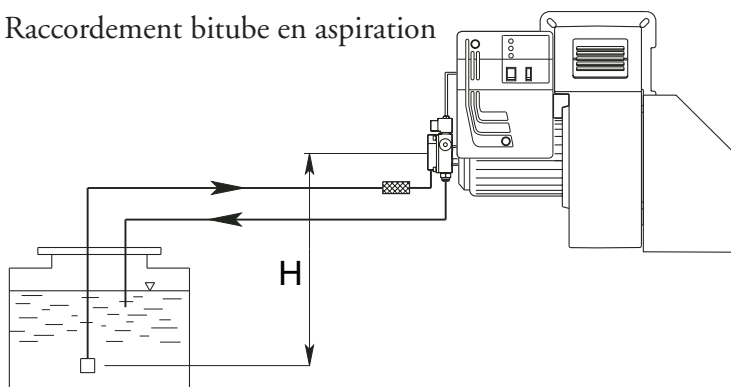
Raccordement bitube en aspiration

H (m)	Longueur tuyaux en mètres			
	AS 67 / AN 77 (m)		AJ 6 (m)	
	ø 10 mm	ø 12 mm	ø 14 mm	ø 16 mm
0	25	70	25	45
0,5	21	62	20	38
1	18	54	18	33
2	10	38	10	20
3	5	20	5	10
3,5	---	10	2	4

La longueur correcte de la canalisation est donnée par la somme de la longueur de toutes les sections rectilignes horizontales et verticales, ainsi que les coudes. La hauteur statique d'aspiration (max. 3.5m) est donnée par la distance entre la vanne de non retour et l'axe pompe du brûleur. La dépression en aspiration ne devra pas dépasser les 0.45 bar; en cas de dépression plus importante, la pompe pourrait s'endommager avec une conséquente augmentation des bruits mécaniques et, à la limite, une panne totale.

PORTEE DES GICLEURS

DELAVAN B - MONARCH PLP

GICLEUR GPH	PRESSION POMPE (bar)						
	10	11	12	13	14	15	16
2,50	9,50	9,97	10,41	10,83	11,24	11,64	12,02
3,00	11,40	11,96	12,49	13,00	13,49	13,96	14,42
3,50	13,30	13,95	14,57	15,17	15,74	16,29	16,83
4,00	15,20	15,94	16,65	17,33	17,99	18,62	19,23
4,50	17,10	17,94	18,73	19,50	20,24	20,95	21,63
5,00	19,00	19,93	20,82	21,67	22,48	23,27	24,04
5,50	20,90	21,92	22,90	23,83	24,73	25,60	26,44
6,00	22,80	23,92	24,98	26,00	26,98	27,93	28,84
6,50	23,70	25,91	27,06	28,17	29,23	30,26	31,25
7,00	26,60	27,90	29,14	30,33	31,48	32,58	33,65
7,50	28,50	29,90	31,22	32,50	33,73	34,91	36,05
8,30	31,54	33,08	34,55	35,97	37,32	38,63	39,90
9,50	36,10	37,87	39,55	41,17	42,72	44,22	45,67
10,50	40,06	41,73	43,74	45,41	47,20	48,90	50,50
12,00	45,60	47,80	50,00	52,00	54,00	55,90	57,70
13,80	52,40	55,00	57,50	59,80	62,10	64,20	66,30
15,30	58,10	61,00	63,70	66,30	68,80	71,10	73,60
17,50	66,50	69,80	72,90	75,80	78,70	81,50	84,10
19,50	74,10	77,70	81,20	84,50	87,70	90,80	93,70
21,50	81,70	85,70	89,50	93,20	96,70	100,10	103,40
24,00	91,20	95,70	99,90	104,00	107,90	111,70	115,40
GPH	DEBIT kg/h						

NETTOYAGE ET REMPLACEMENT DU GICLEUR

Utiliser seulement la clé en dotation, prévue pour cette opération, pour dévisser le gicleur, en veillant à ne pas endommager les électrodes. Monter le nouveau gicleur par le même soin.

Note: Après le remplacement du gicleur, vérifier toujours la position des électrodes (voir à l'illustration). Une position erronée des électrodes pourrait donner des problèmes d'allumage.

FR

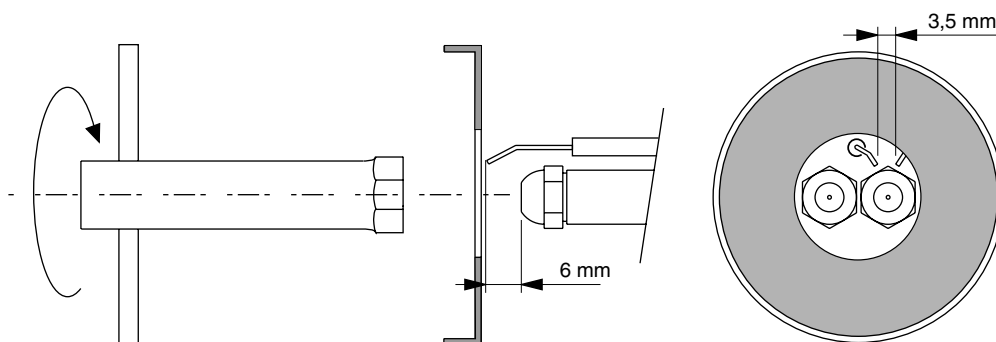

AMORCAGE ET REGULATION DE LA POMPE FIOUL

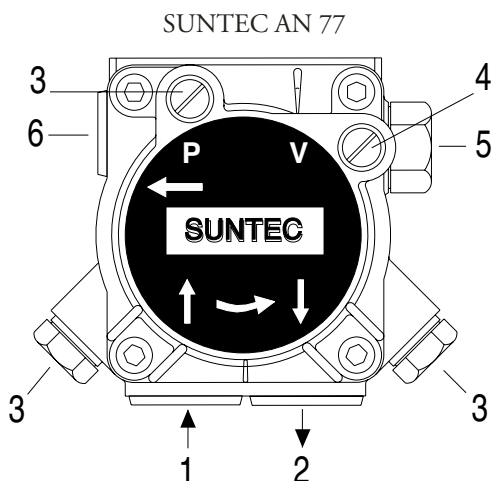
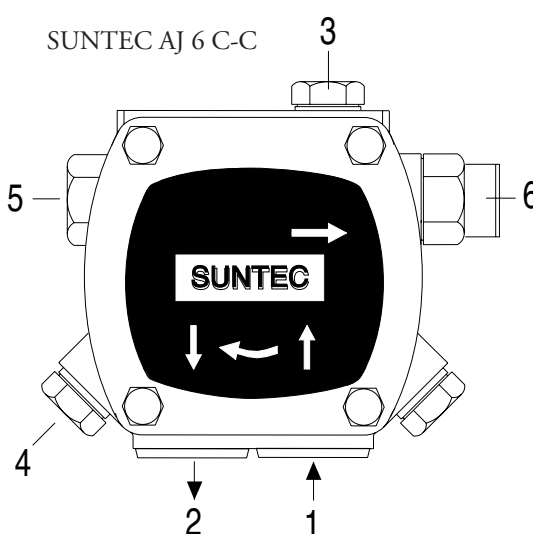
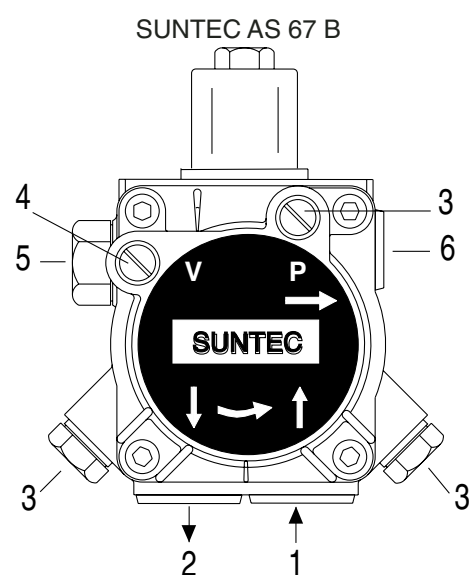

- 1 - ASPIRATION
- 2 - RETOUR
- 3 - RACCORDEMENT DU MANOMETRE ET PURGE
- 4 - RACCORDEMENT DU VACUOMETRE
- 5 - VIS DE REGLAGE DE LA PRESSION
- 6 - AU GICLEUR

VERIFIER:

- Que les canalisations soient parfaitement étanches;
- Qu'on évite l'emploi de tuyaux flexibles, lorsque possible (utiliser, préférablement, tuyaux en cuivre).
- Que la dépression ne dépasse pas 0,45 bar, pour éviter la cavitation de la pompe.
- Que la vanne de non retour soit appropriée

La pression de la pompe est réglée à 12 bar pendant les essais à

l'usine. Avant de démarrer le brûleur, purger l'air contenue dans la pompe à travers la prise du manomètre. Remplir la tuyauterie de fioul pour faciliter l'amorçage de la pompe. Démarrer le brûleur et vérifier la pression d'alimentation de la pompe. S'il dût se passer que l'amorçage de la pompe ne se vérifie pas pendant le premier prebalayage, avec une conséquence, successive mise en sécurité du brûleur, rearmar la mise en sécurité du brûleur pour le démarrer à nouveau, en appuyant sur le bouton du coffret de sécurité. Si, après un amorçage effectué normalement, le brûleur se met en sécurité par faute d'une chute de pression du fioul dans la pompe, rearmar la mise en sécurité pour le redémarrer. Ne jamais laisser que la pompe tourne sans fioul pendant plus

FR

que trois minutes. Dans le cas où l'amorçage de la pompe ne s'effectue pas pendant le premier prebalayage, déclencher la mise en sécurité du brûleur. Note: avant de démarrer le brûleur, s'assurer que le tuyau de retour soit ouvert. Une obstruction éventuelle pourrait causer la rupture du dispositif d'étanchéité de la pompe.

MISE EN SERVICE ET REGLAGE DU BRULEUR

Après avoir effectué l'installation du brûleur, vérifier les points suivants:

- Tension d'alimentation du brûleur et les fusibles de protection de ligne.
- Les connexions du moteur.
- La longueur correcte de la tuyauterie et que la même soit étanche.
- Le type de combustible, qui doit être indiqué pour le brûleur.
- La connexion des thermostats chaudière et des sécurités.
- Le sens de rotation du moteur.
- La calibration correcte de la protection thermique du moteur.

Une fois que toutes ces conditions ont été vérifiées, on pourra procéder aux essais du brûleur.

Alimenter le brûleur. Le coffret de sécurité alimente, en même temps, le transformateur d'allumage et le moteur du brûleur, qui pourvoit à effectuer un prebalayage de la chambre de combustion pendant environ 20 secondes.

A la fin du prebalayage, le coffret de sécurité ouvre l'électrovanne de la pompe fioul et de 1re Allure (Petite allure), le transformateur produit un'étincelle et le brûleur s'allume.

Après un intervalle de sécurité de 5 secondes et un allumage correct, le coffret de sécurité débranche le transformateur d'allumage et, après d'autres 10 secondes, porte le clapet d'air motorisé à son ouverture maximale et ouvre l'électrovanne de 2me Allure (Grande allure).

En cas de faute d'allumage, le coffret de sécurité met le brûleur en sécurité dans les 5 secondes. Dans ce cas, le réarmement manuel ne pourra intervenir qu'après 30 secondes env. de la mise en sécurité du brûleur.

Pour obtenir une combustion optimale, il faudra réguler la portée de l'air en 1re et 2me ALLURE, suivant les instructions données plus après. Pendant cette phase, on pourra passer manuellement de la position de 2me Allure (II) à celle de 1re Allure (I) et viceversa, à l'aide de l'interrupteur de 1re/2me ALLURE. A la fin des réglages, laisser l'interrupteur en position II (2me ALLURE).

La pression d'alimentation de la pompe fioul devra toujours se garder autour de 12 bar.

SEULEMENT POUR LES COFFRETS DE SECURITE LANDIS LMO 44

En cas de mise en sécurité du brûleur on pourra lire la cause qui l'a provoqué. Dans ce cas, procéder comme il suit: avec le brûleur en sécurité (LED rouge allumé) appuyer sur le bouton de réarmement pendant plus de trois secondes et le relâcher. Le LED rouge commencera à clignoter suivant la liste de codes-erreur ci-dessous:

Code-erreur	Cause possible
2 clignotements	Absence de flamme à la fin du temps de sécurité à l'allumage «TSA» - électrovannes défectueuses – détecteur de flamme défectueux - réglage brûleur erroné - électrodes défectueuses
3 clignotements	Non utilisé
4 clignotements	Signal de présence flamme pendant la phase de préventilation
5 clignotements	Non utilisé
6 clignotements	Non utilisé
7 clignotements	Extinctions trop fréquentes de la flamme pendant le fonctionnement (limite de n° de répétitions du cycle dépassée) - électrovannes défectueuses – détecteur de flamme défectueux - réglage brûleur erroné
8 clignotements	Contrôle du temps chauffage combustible
9 clignotements	Non utilisé
10 clignotements	Contacts en sortie défectueux ou panne du dispositif interne

REGLAGE DE LA TETE DE COMBUSTION

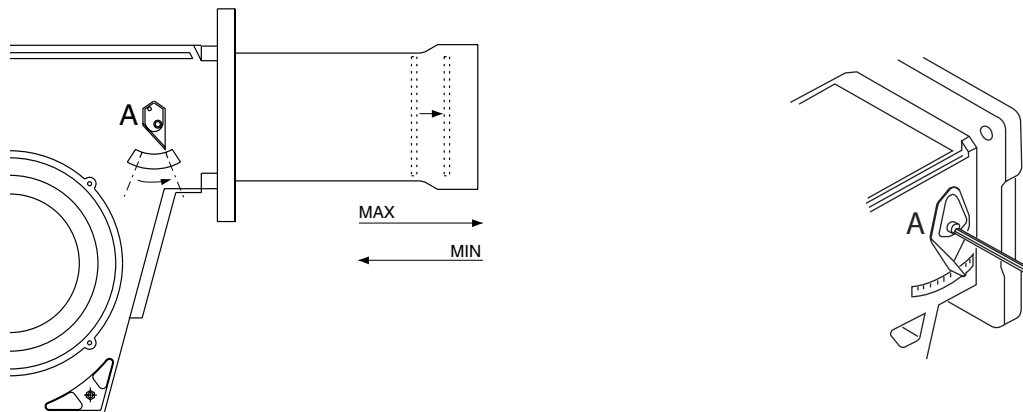

REGLAGE DE LA PORTEE DE L'AIR COMBURANTE (1RE / 2ME ALLURE)

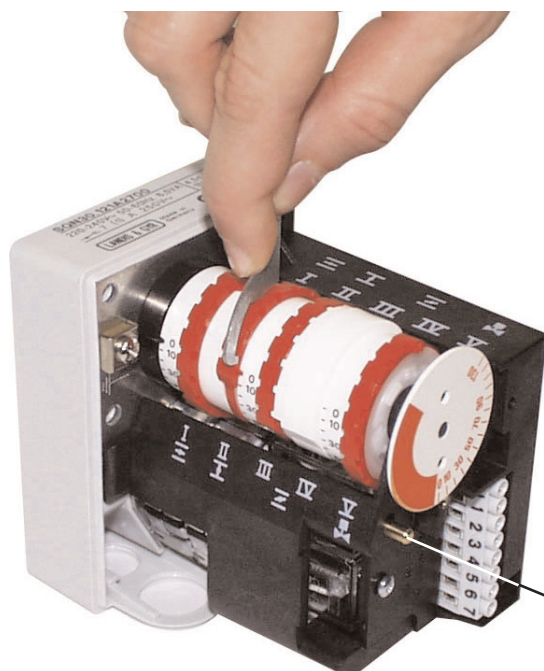

LANDIS SQN 30-31 121A2700

Bouton de debranchement

Enlever le couvercle pour accéder aux cames de régulation. La régulation des cames doit être faite à l'aide de la clé en dotation. Description:

- I - Came de régulation position d'ouverture en 2me. allure (puiss. max.)
- II - Came de régulation de la position du clapet d'air à coupure (fermeture).
- III - Came de régulation position d'ouverture en 1re. allure.
- IV - Commutateur auxiliaire libre (non utilisé)
- V - Came de consentement à l'ouverture de l'électrovanne de 2me. allure.

NOTE : La came V (de consentement à l'ouverture de l'électrovanne de 2me. allure) doit être réglée sur une position intermédiaire entre celle de 1re. allure et de 2me. allure (sous un angle de env. 5° supérieur par rapport à celui de la position de 1re. allure). position intermédiaire entre celle de 1re. allure et de 2me. allure (sous un angle de env. 5° supérieur par rapport à celui de la position de 1re. allure).

BRANCHEMENT ELECTRIQUE

Tous les brûleurs sont essayés à l'usine à 400V - 50Hz triphasé pour les moteurs, et 230V - 50Hz monophasé avec neutre pour les équipements auxiliaires. Dans le cas où il fût nécessaire alimenter le brûleur en 230V - 50Hz triphasé sans neutre, modifier les connexions sur le moteur et sur la boîte à bornes suivant la figure. Protéger la ligne d'alimentation du brûleur par des fusibles appropriés et/ou les autres dispositifs de sécurité suivant les dispositions locales en matière.

CARACTERISTICAS TECNICAS

ES

MODELOS		MAIOR P 45	MAIOR P 60	MAIOR P 80	MAIOR P 120
Potencia térmica máx.	kcal/h	459.000	600.000	800.000	1.200.000
	kW	532	710	949	1423
Potencia térmica mín.	kcal/h	255.000	350.000	400.000	700.000
	kW	296	415	474	830
Caudal máx. de gasóleo	kg/h	45	60	80	120
Caudal mín. de gasóleo	kg/h	25	35	40	70
Aliment.eléct.	50 Hz V	230/400	230/400	230/400	230/400
Potencia del motor	kW	0,55	0,74	1,1	2,2
Revol. por minuto	Nº	2.800	2.800	2.800	2.800
Transformador de encendido	kV/mA	10/20	10/20	10/20	10/20
Equipo de control de la llama	LANDIS	LMO 44	LMO 44	LMO 44	LMO 44
Combustible : gasóleo	kcal/kg	10.200 max. visc 1,5°E a 20°C			

CURVAS DE TRABAJO

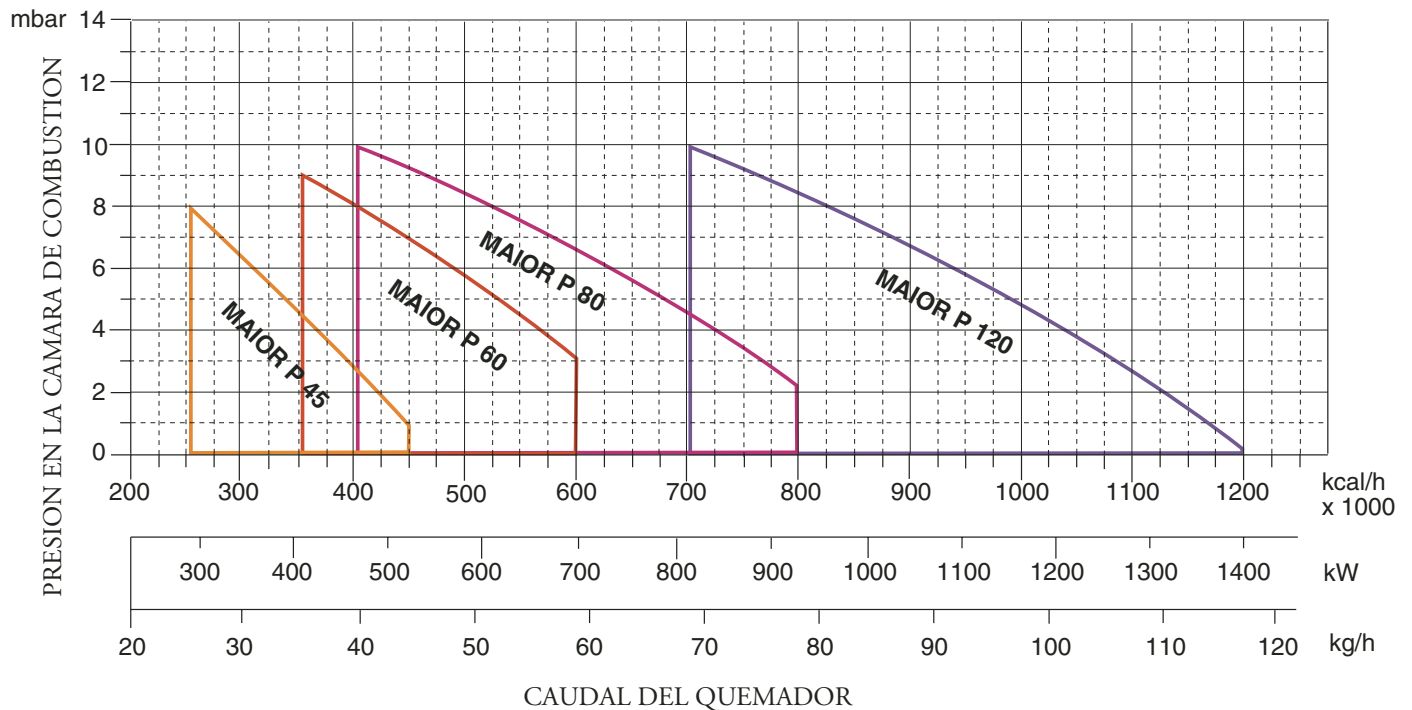

DIMENSIONES GLOBALES

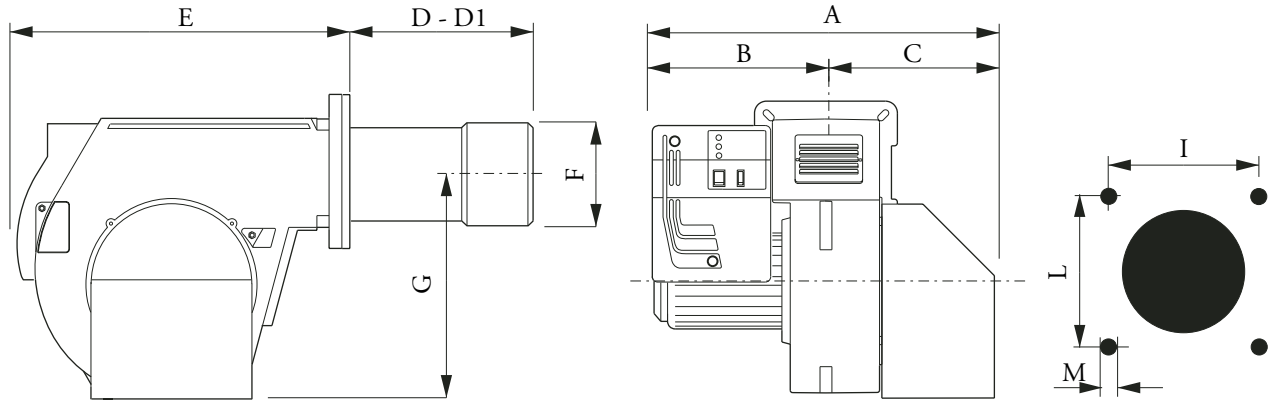

ES

MODELOS	A	B	C	D	D1	E	F	G	I	L	M
MAIOR P 45 AB	590	330	260	225	385	555	160	376	190	190	M10
MAIOR P 60 AB	590	330	260	230	390	555	180	376	190	190	M10
MAIOR P 80 AB	590	330	260	230	390	555	180	376	190	190	M10
MAIOR P 120 AB	690	350	340	220	440	555	190	376	190	190	M10

D = cabeza corta D1 = cabeza larga

INSTALACION DEL QUEMADOR

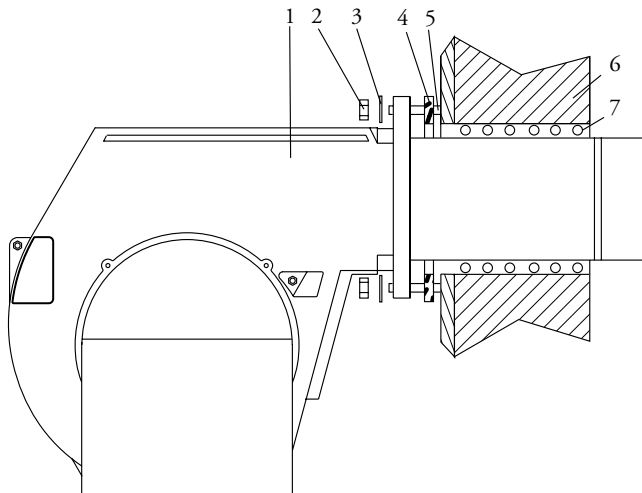

- 1 - QUEMADOR
- 2 - DADO
- 3 - ANILLO
- 4 - JUNTA
- 5 - TUERCA
- 6 - CALDERA
- 7 - CORDON AISLANTE

SISTEMA HIDRÁULICO

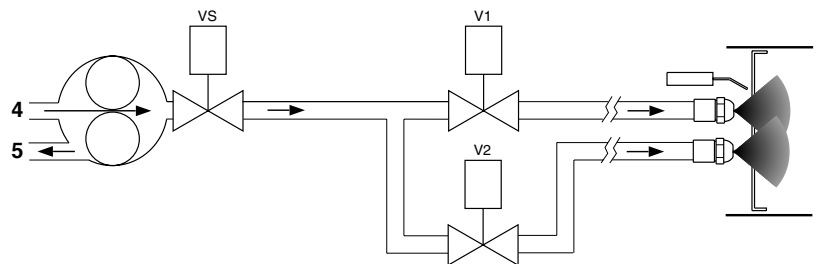
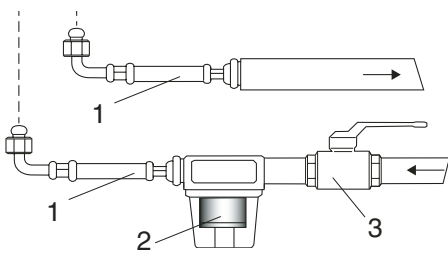

- 1 - LATIGUILLOS
- 2 - FILTRO
- 3 - VÁLVULA DE CORTE
- 4 - ASPIRACIÓN
- 5 - RETORNO

ALIMENTACION DEL COMBUSTIBLE

ES Tubo doble de la parte superior del depósito

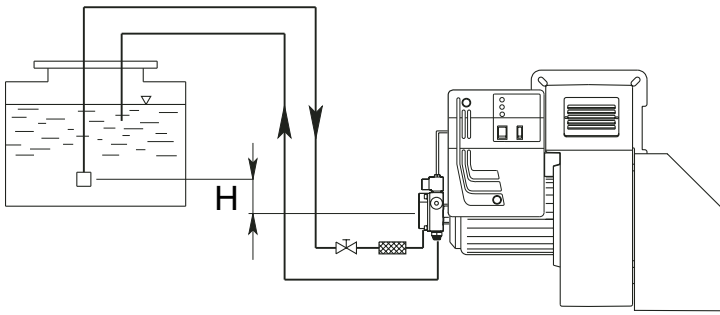

H (m)	Longitud de los tubos			
	AS 67 / AN 77 (m)		AJ 6 (m)	
	ø 10 mm	ø 12 mm	ø 14 mm	ø 16 mm
0	32	90	22	38
0,5	36	90	25	45
1	40	90	30	50
2	48	90	35	60
3	56	90	38	70
3,5	60	90	40	80

Tubo doble de aspiración

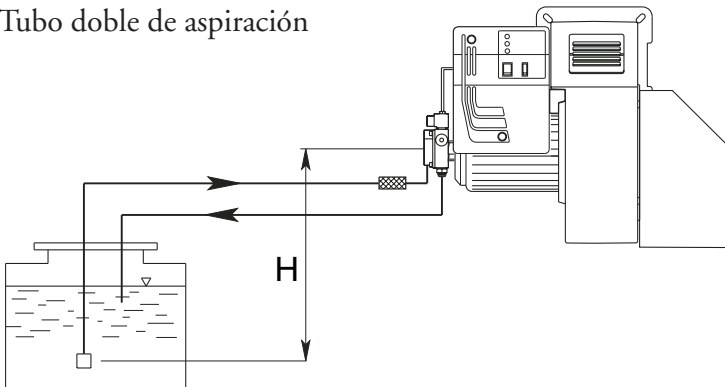

H (m)	Longitud de los tubos			
	AS 67 / AN 77 (m)		AJ 6 (m)	
	ø 10 mm	ø 12 mm	ø 14 mm	ø 16 mm
0	25	70	25	45
0,5	21	62	20	38
1	18	54	18	33
2	10	38	10	20
3	5	20	5	10
3,5	---	10	2	4

La longitud de la tubería se obtiene de la suma de todas las secciones rectilíneas horizontales y verticales y de las curvas. La altura estática de aspiración (máx. 3.5m) es la distancia entre la válvula anti retorno y el eje bomba del quemador. La depresión no debe superar los 0.45 bar; una depresión mas grande podría perjudicar el funcionamiento de la bomba, con consecuente aumento del ruido mecánico y , al final, una ruptura.

CAUDAL DE LOS INYECTORES

DELAVAN B - MONARCH PLP

INYECTOR GPH	PRESION BOMBA (bar)						
	10	11	12	13	14	15	16
2,50	9,50	9,97	10,41	10,83	11,24	11,64	12,02
3,00	11,40	11,96	12,49	13,00	13,49	13,96	14,42
3,50	13,30	13,95	14,57	15,17	15,74	16,29	16,83
4,00	15,20	15,94	16,65	17,33	17,99	18,62	19,23
4,50	17,10	17,94	18,73	19,50	20,24	20,95	21,63
5,00	19,00	19,93	20,82	21,67	22,48	23,27	24,04
5,50	20,90	21,92	22,90	23,83	24,73	25,60	26,44
6,00	22,80	23,92	24,98	26,00	26,98	27,93	28,84
6,50	23,70	25,91	27,06	28,17	29,23	30,26	31,25
7,00	26,60	27,90	29,14	30,33	31,48	32,58	33,65
7,50	28,50	29,90	31,22	32,50	33,73	34,91	36,05
8,30	31,54	33,08	34,55	35,97	37,32	38,63	39,90
9,50	36,10	37,87	39,55	41,17	42,72	44,22	45,67
10,50	40,06	41,73	43,74	45,41	47,20	48,90	50,50
12,00	45,60	47,80	50,00	52,00	54,00	55,90	57,70
13,80	52,40	55,00	57,50	59,80	62,10	64,20	66,30
15,30	58,10	61,00	63,70	66,30	68,80	71,10	73,60
17,50	66,50	69,80	72,90	75,80	78,70	81,50	84,10
19,50	74,10	77,70	81,20	84,50	87,70	90,80	93,70
21,50	81,70	85,70	89,50	93,20	96,70	100,10	103,40
24,00	91,20	95,70	99,90	104,00	107,90	111,70	115,40
GPH	CAUDAL kg/h						

LIMPIEZA Y SOSTITUCIÓN DEL INYECTOR

Utilizar solamente la llave de suministro para desmontar el inyector, teniendo cuidado de no estropear los electrodos. Montar el nuevo inyector con el mismo cuidado.

Nota: Comprobar todavía la posición de los electrodos después del montaje (ver a la ilustración). Una posición errada puede originar problemas de encendido.

ES

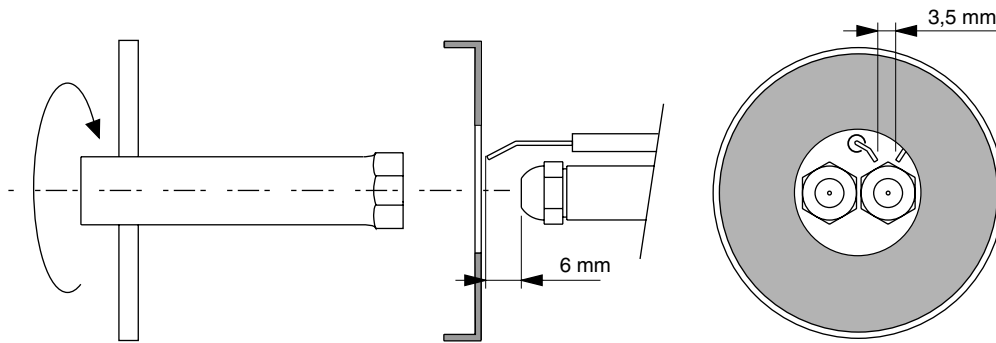

CEBADO Y REGULACION DE LA BOMBA GASOLEO

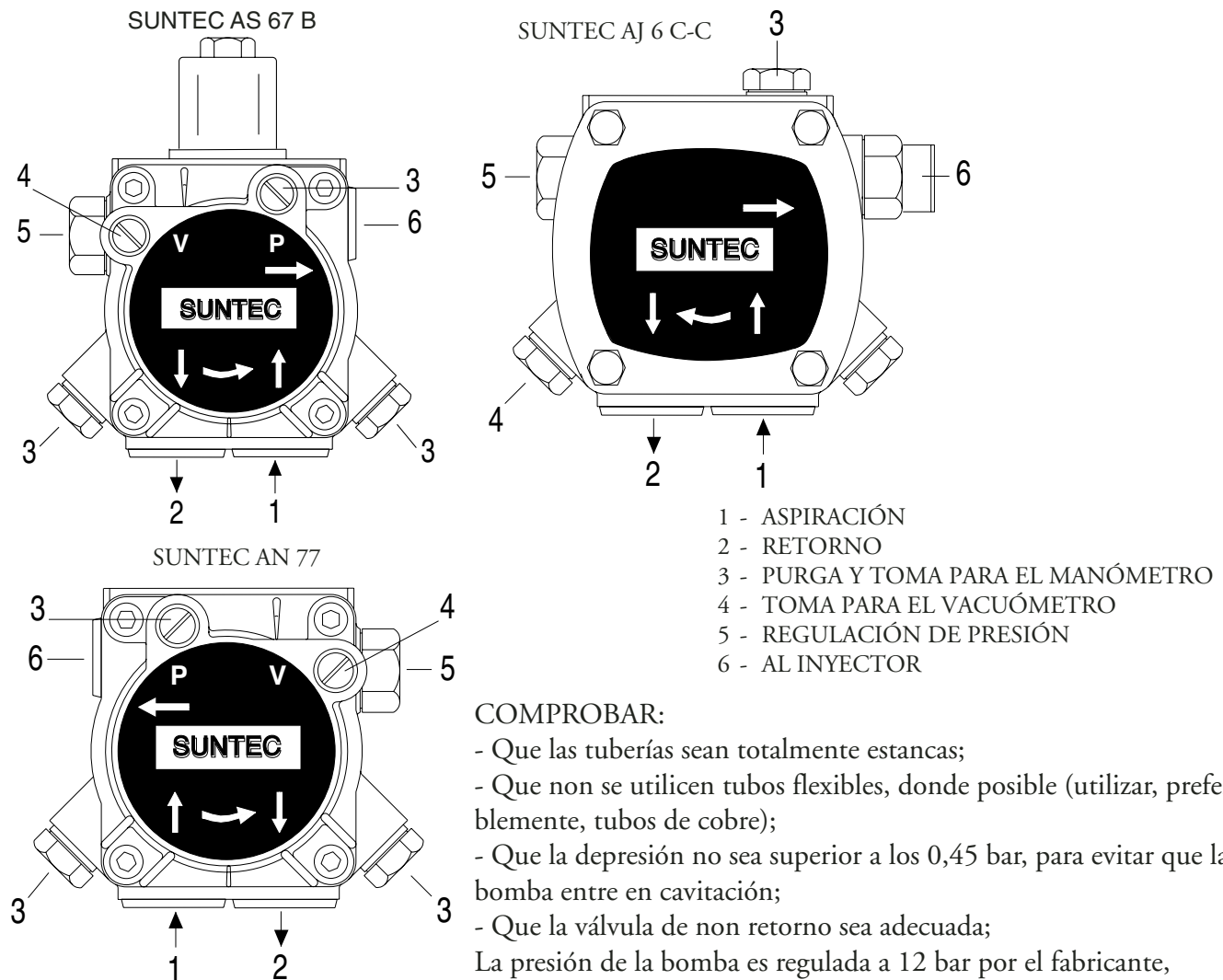

Antes de arrancar el quemador, purgar el aire contenido en la bomba a través la toma para el manómetro. Llenar las tuberías con gasóleo, para facilitar el cebado de la bomba. Arrancar el quemador y comprobar la presión de alimentación de la bomba. Si se verificases que el cebado de la bomba no se efectúa durante el primer prebarrido, con consecuente, sucesivo bloqueo del quemador, rearmar el bloqueo para arrancarlo nuevamente, presionando el botón del equipo de control. Si, una vez que el cebado se ha efectuado normalmente, el quemador se bloquee después del prebarrido, por falta de presión del gasóleo en la bomba, armar el blo-

ES

queo para arrancarlo nuevamente. Nunca permitir que la bomba funcione sin gasóleo durante más de tres minutos. Nota: antes de poner en marcha el quemador, comprobar que el tubo de retorno esté abierto. Una oclusión eventual, podría estropear el elemento de estanqueidad de la bomba. del prebarrido, por falta de presión del gasóleo en la bomba, armar el bloqueo para arrancarlo nuevamente. Nunca permitir que la bomba funcione sin gasóleo durante más de tres minutos. Nota: antes de poner en marcha el quemador, comprobar que el tubo de retorno esté abierto. Una oclusión eventual, podría estropear el elemento de estanqueidad de la bomba.

FUNCIONAMIENTO Y REGULACIÓN DEL QUEMADOR

Después de haber instalado el quemador, comprobar los puntos siguientes:

- La tensión de alimentación del quemador y los fusibles de protección de línea.
- Las conexiones del motor.
- La largueza correcta y la estanqueidad de la tubería.
- El tipo de combustible, que debe ser adecuado para el quemador.
- Las conexión de los termostatos de caldera y de los dispositivos de seguridad.
- El sentido de rotación del motor.
- La regulación correcta de la protección térmica del motor.

Cuando todas estas condiciones se cumplen, es posible de proceder con las pruebas del quemador.

Alimentar el quemador. El equipo de control alimenta, al mismo tiempo, el transformador de encendido y el motor del quemador, que empieza el prebarrido de la cámara de combustión por unos 20 segundos.

Al termino del prebarrido, el equipo de control abre la electroválvula de la bomba de gasóleo y la electroválvula de 1a Llama (Baja llama), el transformador de encendido genera una chispa y el quemador se enciende.

Después de un intervalo de seguridad de 5 segundos, y un encendido correcto, el equipo de control desconecta el transformador de encendido y, después otros 10 segundos manda el cierre del aire motorizado en posición de abertura máxima y abre la electroválvula de 2a Llama (Alta llama).

En caso de falta de encendido, el equipo de control pone el quemador en posición de seguridad dentro de los 5 segundos. En este caso, el rearme manual del quemador no podrá ocurrir antes que se hayan pasado unos 30 segundos de la misa en seguridad del quemador.

Para obtener una combustión optimal, se necesitara regular el caudal del aire en 1a y 2a llama, siguiendo las instrucciones facilitadas más adelante en este manual. Durante esta fase, se podrá pasar manualmente de la 2a LLAMA (II) a la 1a LLAMA (I) y viceversa, por medio del interruptor de 1a/2a Llama. Al termino de la fase de regulación, dejar el interruptor en posición II (2a Llama).

La presión de alimentación de la bomba debe estar acerca de los 12 bar.

SOLO PARA EQUIPOS DE CONTROL LLAMA LANDIS LMO 44

En caso de bloqueo del quemador, es disponible la indicación del origen del bloqueo. Actuar de la manera siguiente: con el quemador en seguridad (LED rojo encendido) presionar por más de tres segundos el botón de rearme manual y aflojarlo. El LED rojo empezará a encenderse de luz intermitente, según la lista siguiente de códigos de error:

Códigos de error	Posible causa
2 parpadeos	Ausencia de llama al final del tiempo de seguridad en el encendido "TSA" -Electroválvula defectuosa -revelación de llama defectuoso -regulación del quemador incorrecta -electrodos defectuosos
3 parpadeos	No utilizado
4 parpadeos	Luz extraña durante la fase de prevarrido
5 parpadeos	No utilizado
6 parpadeos	No utilizado
7 parpadeos	Falta de llama durante el funcionamiento (superado el límite de nº de repeticiones del ciclo) -Electroválvula defectuosa -Revelación de llama defectuoso -Regulación del quemador incorrecta
8 parpadeos	Control del tiempo de calentamiento del combustible
9 parpadeos	No utilizado
10 parpadeos	Contacto en la salida defectuoso o estropeado dispositivo interno

REGULACION CABEZA DE COMBUSTION

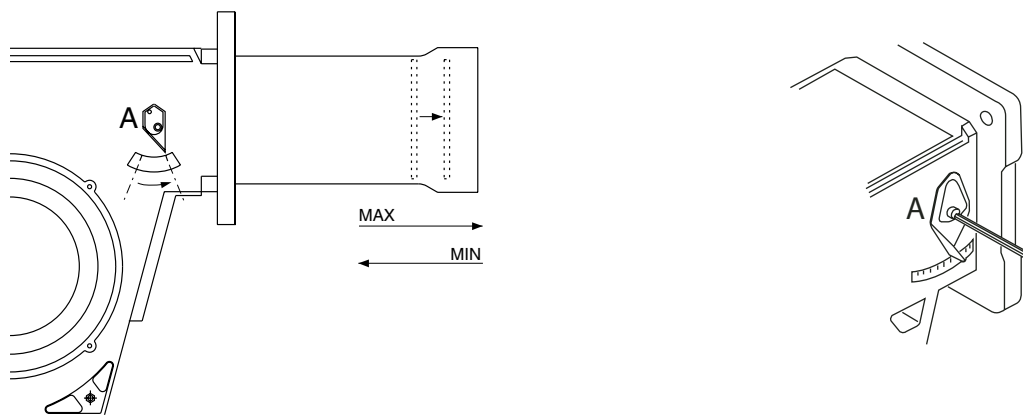

ES

REGULACIÓN DEL CAUDAL DEL AIRE DE COMBUSTIÓN

LANDIS SQN 30-31 121A2700



Remover la tapa para acceder a los dientes de regulación. La regulación de los dientes tiene que ser efectuado con su apropiada llave de suministro. Descripción

- I - Diente de regulación abertura del cierre del aire en 2a llama (potencia máx.)
- II - Diente de regulación de la posición del cierre al apagado (cierre)
- III - Diente de regulación de la posición de abertura en 1a llama
- IV - Diente de regulación no utilizado.
- V - Diente del consentimiento abertura de la electroválvula de 2a llama

NOTA: El diente V (de consentimiento del abertura de la electroválvula de 2a llama) tiene que ser regulado en una posición intermedia entre la de la 1a llama y la de la 2a (bajo un ángulo cerca de 5° superior a lo de la posición de la 1a llama).

CONEXIONES ELECTRICAS

Todos los quemadores son ensayados por el fabricante a 400V - 50Hz trifásico para el motor, y 230V - 50Hz monofásico con neutro para los equipos auxiliares. En caso que fuese necesario alimentar el quemador con 230V - 50Hz trifásico sin neutro, modificar las conexiones del motor y en el tablero de bornes siguiendo la ilustración. Proteger la línea de alimentación del quemador con fusibles adecuados y/o con todos los dispositivos de seguridad especificados por las normas locales en materia.

ТЕХНИЧЕСКИЕ ХАРАКТЕРИСТИКИ

RU

MODELLO		MAIOR P 45	MAIOR P 60	MAIOR P 80	MAIOR P 120
Максимальная теплопроизводительность	ккал/ч	459.000	600.000	800.000	1.200.000
	кВт	532	710	949	1423
Минимальная теплопроизводительность	ккал/ч	255.000	350.000	400.000	700.000
	кВт	296	415	474	830
Максимальный расход дизтоплива	кг/ч	45	60	80	120
Минимальный расход дизтоплива	кг/ч	25	35	40	70
Напряжение электропитания	50 Гц В	230/400	230/400	230/400	230/400
Мощность двигателя	кВт	0,55	0,74	1,1	2,2
Двигатель	об/мин	2.800	2.800	2.800	2.800
Трансформатор розжига	кВ/мА	10/20	10/20	10/20	10/20
Устройство контроля пламени	LANDIS	LMO 44	LMO 44	LMO 44	LMO 44
Топливо : дизельное топливо	ккал/кг	10.200 макс. вязкость 1,5°E при 20°C			

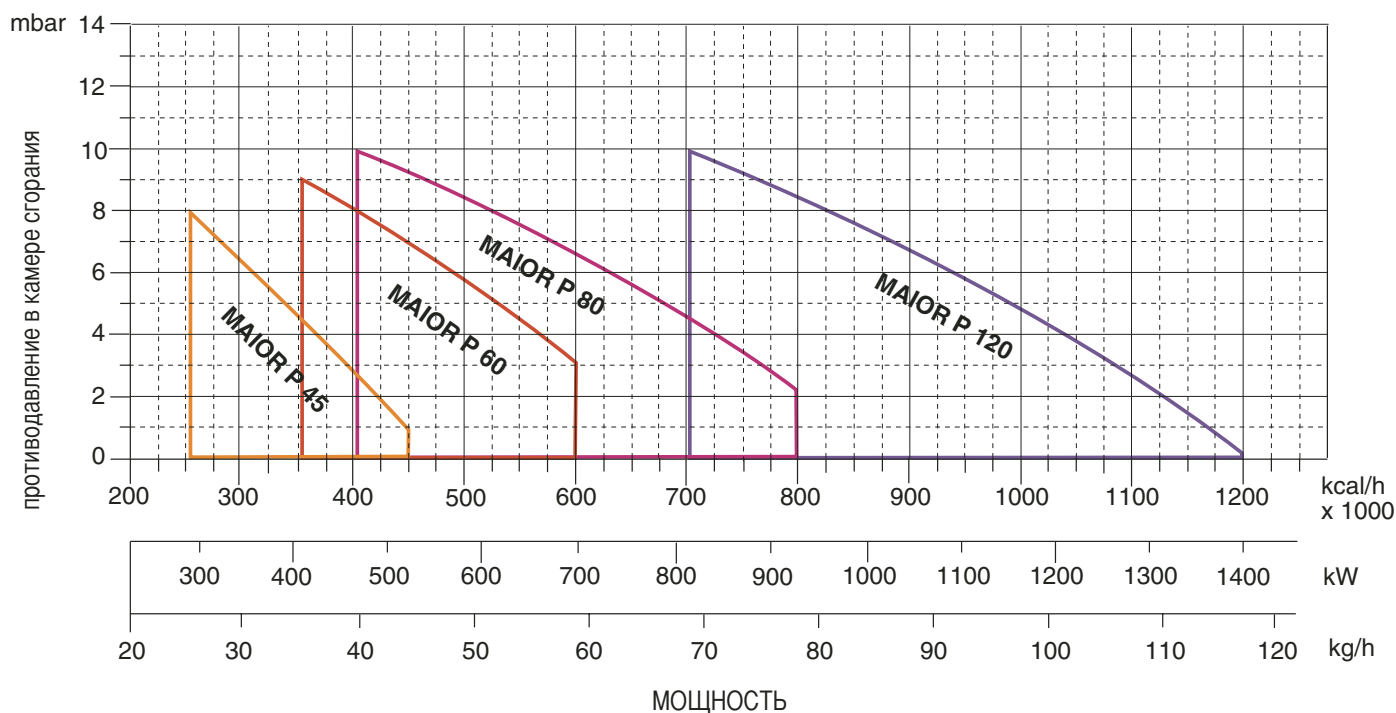
РАБОЧИЙ ДИАПАЗОН

ГАБАРИТНЫЕ РАЗМЕРЫ

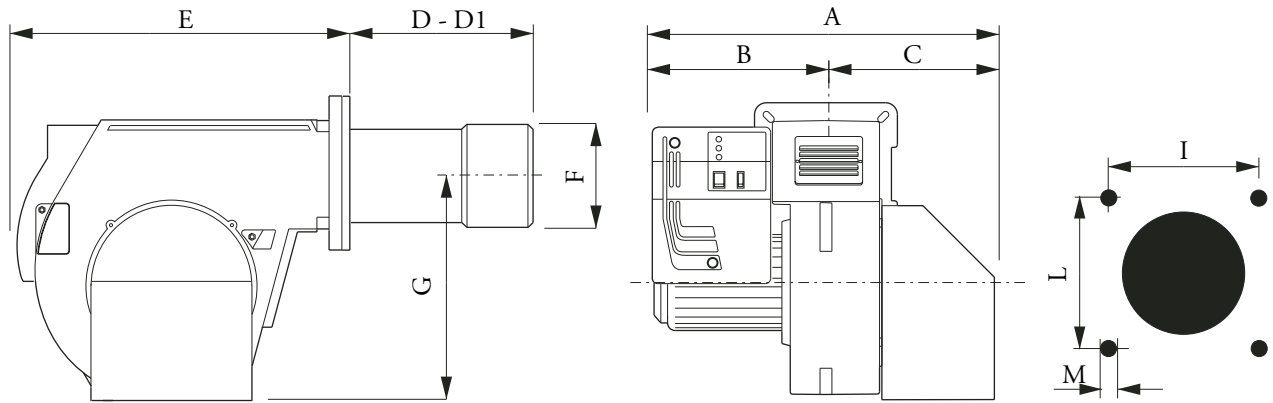

RU

МОДЕЛЬ	A	B	C	D	D1	E	F	G	I	L	M
MAIOR P 45 AB	590	330	260	225	385	555	160	376	190	190	M10
MAIOR P 60 AB	590	330	260	230	390	555	180	376	190	190	M10
MAIOR P 80 AB	590	330	260	230	390	555	180	376	190	190	M10
MAIOR P 120 AB	690	350	340	220	440	555	190	376	190	190	M10

ГОЛОВКА ГОРЕЛКИ: D = КОРОТКАЯ D1= ДЛИННАЯ

МОНТАЖ ГОРЕЛКИ

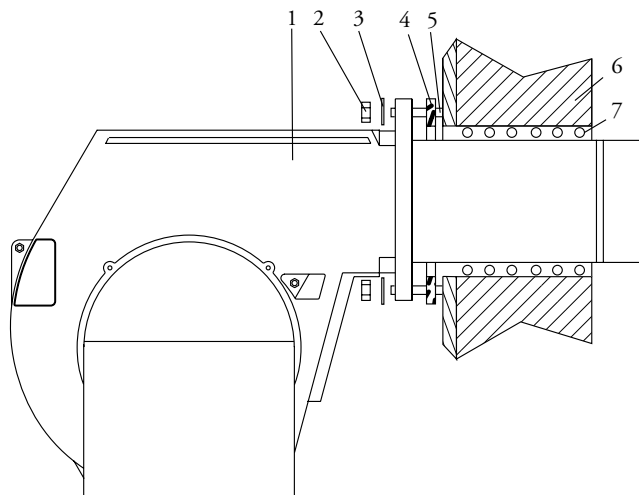

- 1 - ГОРЕЛКА
- 2 - ГАЙКА
- 3 - ШАЙБА
- 4 - ПРОКЛАДКА ISOMART
- 5 - РЕЗЬБОВАЯ ШПИЛЬКА
- 6 - КОТЕЛ
- 7 - "КОСИЧКА" ИЗ СТЕКЛОВОЛОКНА

ГИДРАВЛИЧЕСКАЯ СХЕМА

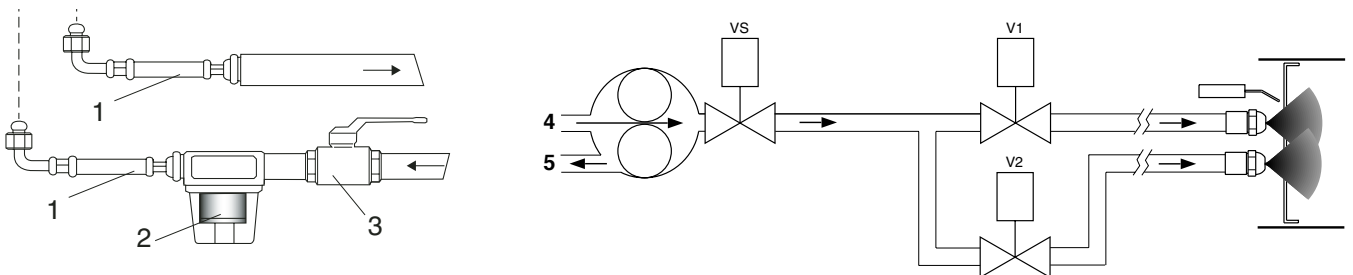

- 1 - ГИБК. ШЛАНГ
- 2 - ФИЛЬТР
- 3 - ВЕНТИЛЬ
- 4 - ВСАСЫВАНИЕ
- 5 - ОБРАТН. КОНТУР

СИСТЕМЫ ПОДАЧИ ТОПЛИВА

Бак выше оси насоса

RU

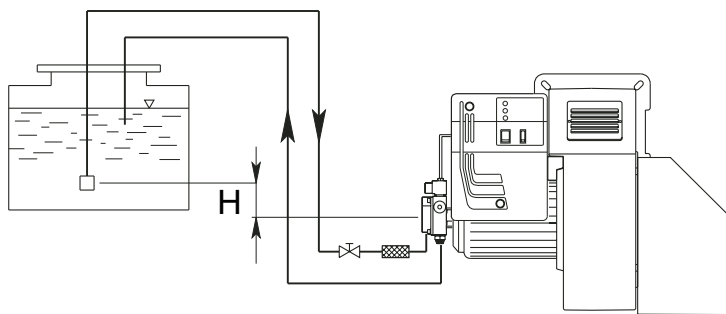

от оси насоса (м)	Длина топливопровода (м)			
	AS 67 / AN 77 (м)		AJ 6 (м)	
	ø 10 mm	ø 12 mm	ø 14 mm	ø 16 mm
0	32	90	22	38
0,5	36	90	25	45
1	40	90	30	50
2	48	90	35	60
3	56	90	38	70
3,5	60	90	40	80

Бак ниже оси насоса

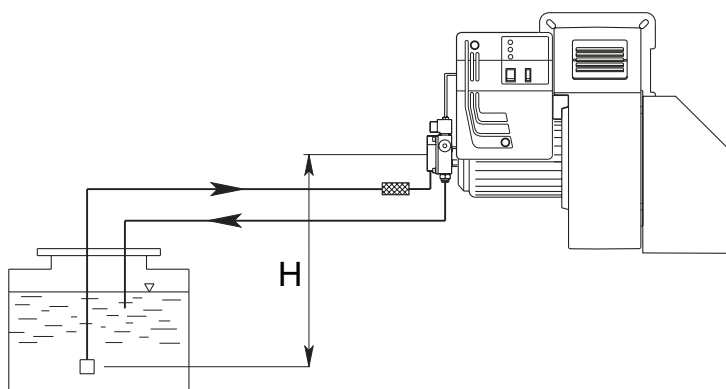

от оси насоса (м)	Длина топливопровода (м)			
	AS 67 / AN 77 (м)		AJ 6 (м)	
	ø 10 mm	ø 12 mm	ø 14 mm	ø 16 mm
0	25	70	25	45
0,5	21	62	20	38
1	18	54	18	33
2	10	38	10	20
3	5	20	5	10
3,5	---	10	2	4

Длина топливопровода равняется сумме длин всех прямолинейных отрезков, горизонтальных и вертикальных, и поворотов. Статическая высота всасывания (не более 3,5 м) равняется расстоянию между донным клапаном и осью насоса горелки. Разрежение не должно превышать 0,45 бар; превышение данной величины может повлечь за собой повышенный износ насоса, повышенный уровень шума и, в конечном итоге, выход из строя насоса.

ПРОИЗВОДИТЕЛЬНОСТЬ ГОРЕЛОК

DELAVAN B - MONARCH PLP

ФОРСУНКА галлон/час	ДАВЛЕНИЕ НАСОСА (бар)						
	10	11	12	13	14	15	16
2,50	9,50	9,97	10,41	10,83	11,24	11,64	12,02
3,00	11,40	11,96	12,49	13,00	13,49	13,96	14,42
3,50	13,30	13,95	14,57	15,17	15,74	16,29	16,83
4,00	15,20	15,94	16,65	17,33	17,99	18,62	19,23
4,50	17,10	17,94	18,73	19,50	20,24	20,95	21,63
5,00	19,00	19,93	20,82	21,67	22,48	23,27	24,04
5,50	20,90	21,92	22,90	23,83	24,73	25,60	26,44
6,00	22,80	23,92	24,98	26,00	26,98	27,93	28,84
6,50	23,70	25,91	27,06	28,17	29,23	30,26	31,25
7,00	26,60	27,90	29,14	30,33	31,48	32,58	33,65
7,50	28,50	29,90	31,22	32,50	33,73	34,91	36,05
8,30	31,54	33,08	34,55	35,97	37,32	38,63	39,90
9,50	36,10	37,87	39,55	41,17	42,72	44,22	45,67
10,50	40,06	41,73	43,74	45,41	47,20	48,90	50,50
12,00	45,60	47,80	50,00	52,00	54,00	55,90	57,70
13,80	52,40	55,00	57,50	59,80	62,10	64,20	66,30
15,30	58,10	61,00	63,70	66,30	68,80	71,10	73,60
17,50	66,50	69,80	72,90	75,80	78,70	81,50	84,10
19,50	74,10	77,70	81,20	84,50	87,70	90,80	93,70
21,50	81,70	85,70	89,50	93,20	96,70	100,10	103,40
24,00	91,20	95,70	99,90	104,00	107,90	111,70	115,40
галлон/час	ПРОИЗВОДИТЕЛЬНОСТЬ (кг/час)						

ЧИСТКА И ЗАМЕНА ФОРСУНКИ

Для демонтажа форсунки использовать исключительно поставляемый в комплекте ключ. Обратит внимание, чтобы не повредить электроды. Также аккуратно установить новую форсунку.

Внимание: в заключение проверить положение электродов (см. рис.). Неправильное положение электродов может повлечь за собой трудности при розжиге горелки.

RU

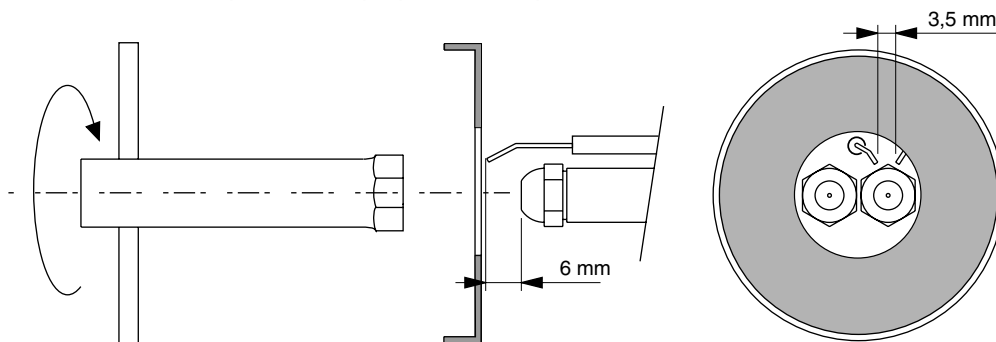

ПУСК И РЕГУЛИРОВАНИЕ ТОПЛИВНОГО НАСОСА

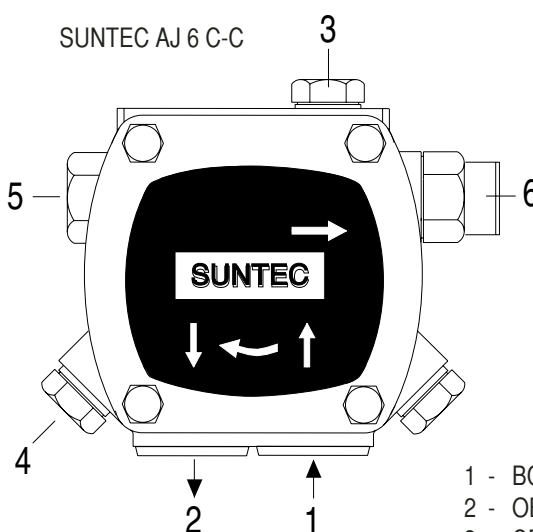
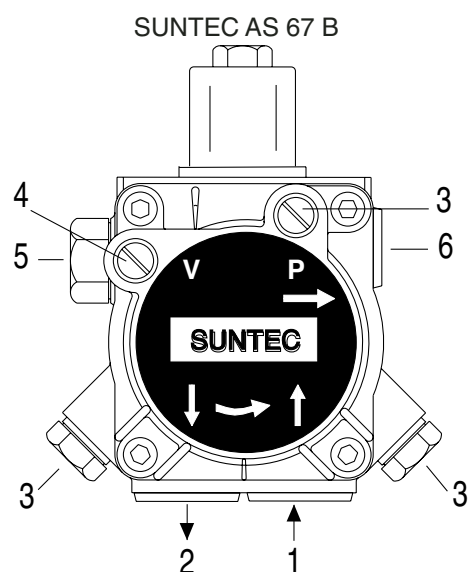

- 1 - ВСАСЫВАНИЕ
- 2 - ОБРАТНЫЙ КОНТУР
- 3 - СПУСКНИК И ОТБОР ДАВЛЕНИЯ
- 4 - ГНЕЗДО ВАКУУММЕТРА
- 5 - РЕГУЛЯТОР ДАВЛЕНИЯ
- 6 - К ФОРСУНКЕ

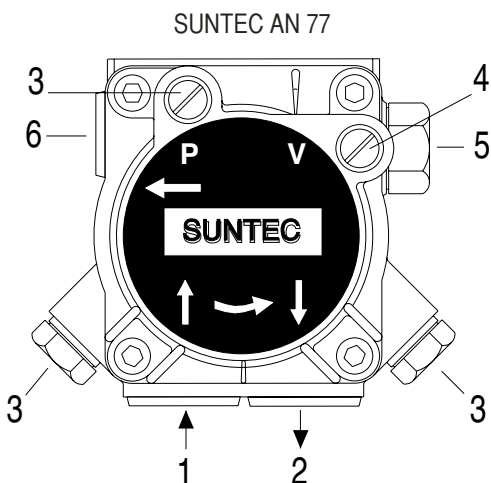

ПРОВЕРИТЬ ПЕРЕД ПУСКОМ:

- Герметичность трубопроводов (рекомендуется по возможности использовать жесткие трубы (медные));
- Для предупреждения кавитации насоса разрежение не должно превышать 0,45 бар;
- Убедиться, что установленный донный клапан имеет требуемые размеры;

Во время испытаний горелки насос тарируется на давление 12 бар.

Перед запуском горелки следует стравить через гнездо отбора давления содержащийся в насосе воздух. Для облегчения пуска насоса заполнить топливопровод топливом. Запустить горелку и

проверить давление на выходе из насоса. Если запуск насоса не произошел во время предварительной промывки и, как следствие, произошла блокировка горелки, следует произвести перезапуск горелки, нажав для этого красную кнопку, расположенную на контрольном устройстве. Если пуск насоса прошел нормально, но вследствие падения давления топлива в насосе после предварительной промывки произошла блокировка горелки, произвести перезапуск оборудования. Работа насоса без топлива в течение более, чем 3 минут запрещается.

Внимание: Перед запуском горелки следует убедиться, что обратный контур топливопровода открыт. Если обратный контур перекрыт, последует немедленное разрушение насоса.

ЗАПУСК И РЕГУЛИРОВАНИЕ ГОРЕЛКИ

По завершении монтажа горелки следует проверить следующее:

- Напряжение электроснабжения горелки и предохранители.
- Правильность подключения двигателя.
- Правильность выбора длины топливопровода и его герметичность.
- Тип топлива должен соответствовать модели горелки.
- Соединения термостатов котла и предохранительной аппаратуры.
- Направление вращения двигателя.
- Правильность тарирования теплового реле двигателя.

При положительных результатах проверки можно приступать к испытанию горелки.

Подать напряжение на горелку. Контрольная аппаратура подает напряжение на трансформатор розжига и одновременно с этим на двигатель горелки - начинается предварительная промывка камеры сгорания, которая длится около 20 секунд.

По завершении предварительной промывки по импульсу, подаваемому контрольной аппаратурой, напряжение подается на электроклапан топливного насоса и клапан 1-й ступени горелки, трансформатор розжига создает искру и происходит розжиг факела горелки. По истечении 5 секунд аварийного времени контрольная аппаратура отключает трансформатор и еще через 10 секунд дает команду на максимальное открытие воздушной заслонки и открывает клапан 2-й ступени (максимальная мощность).

В случае неудачного розжига контрольная аппаратура блокирует горелку в течение 5 секунд. В таком случае ручной перезапуск горелки возможен не ранее, чем по истечении 30 секунд после блокировки. Для получения оптимального качества сгорания следует выполнить регулирование расхода воздуха на 1-й и 2-й ступенях мощности горелки (см. далее). Во время регулирования расхода переключение с 1-й на 2-ую ступень мощности и обратно производится с помощью режимов мощности переключателя. По завершении регулирования переключатель должен оставаться в положении 2-й ступени мощности (поз. II) Давление топлива после насоса должно составлять около 12 бар.

ТОЛЬКО ДЛЯ ЭЛЕКТРОННОЙ АППАРАТУРЫ LANDIS IMO 44

На случай аварийной блокировки горелки предусмотрена система диагностики причин, повлекших за собой блокировку. Диагностика осуществляется следующим образом: При действующей аварийной блокировке (горит индикатор красного цвета) нажмите и не отпускайте в течение 3 секунд кнопку перезапуска. Индикатор красного цвета начинает мигать. Причины блокировки расшифровываются, как показано в таблице ниже:

Код ошибки	Возможная причина
2 импульса	По истечении времени аварийной остановки розжиг не произошел - вышли из строя электроклапаны - вышел из строя электрод обнаружения пламени - - неправильно отрегулирована горелка - вышли из строя электроды
3 импульса	Не используется
4 импульса	Посторонние источники света во время предварительной продувки.
5 импульсов	Не используется
6 импульсов	Не используется
7 импульсов	Исчерпано предельное количество гашений факела во время работы (превышен предел повторов цикла). - вышли из строя электроклапаны - вышел из строя электрод обнаружения пламени - неправильно отрегулирована горелка
8 импульсов	Контроль времени подогрева топлива
9 импульсов	Не используется
10 импульсов	Неисправны контакты на выходе или внутренняя неисправность аппаратуры

РЕГУЛИРОВАНИЕ ПОЛОЖЕНИЯ ГОЛОВКИ ГОРЕЛКИ

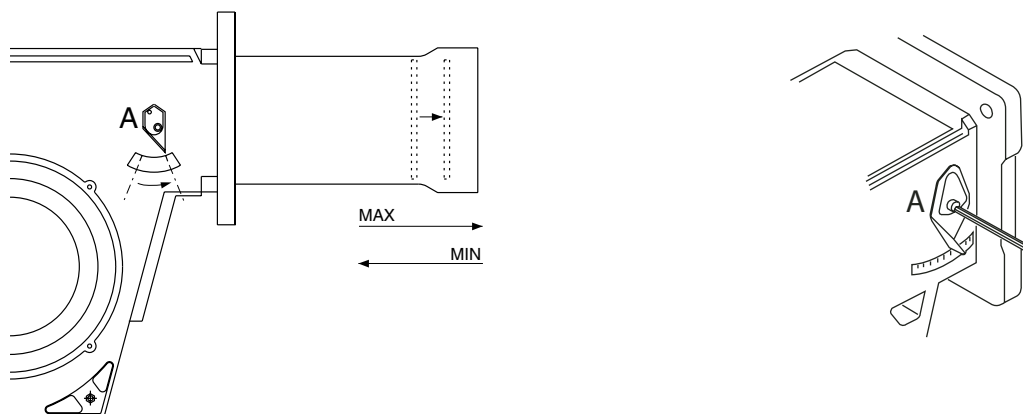

RU

РЕГУЛИРОВКА РАСХОДА ВОЗДУХА (1-я и 2-я ступень мощности)

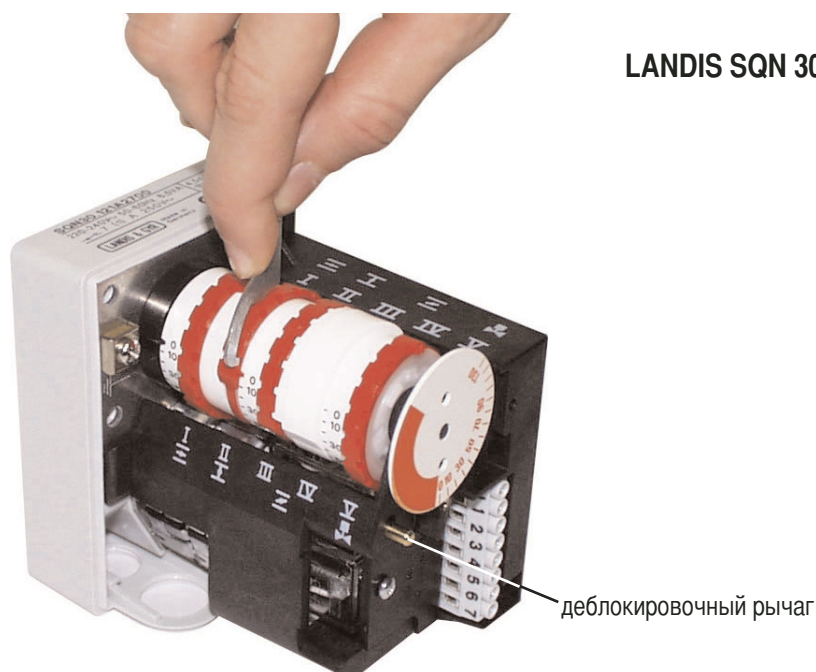

LANDIS SQN 30-31 121A2700

Демонтируйте крышку корпуса для доступа к регуляторам. Осуществите настройку регуляторов в соответствии со следующими указаниями:

I – Ограничительный переключатель для установки воздушной заслонки в положение HIGH FLAME (Максимальная мощность).

II – Данный регулятор позволяет закрывать воздушную заслонку.

III – Ограничительный переключатель для установки воздушной заслонки в положение LOW FLAME.

IV – Данный регулятор включает режим NOT USED.

V – Дополнительный регулятор для перевода горелки на вторую ступень (HIGH FLAME).

ПРИМЕЧАНИЕ: Регулятор V (позволяет открывать электромагнитный клапан 2-ой ступени) установлен в промежуточное положение (угол приблизительно на 50 больше, чем в режиме низкого пламени).

ЭЛЕКТРИЧЕСКИЕ СОЕДИНЕНИЯ

Все двигатели горелок прошли заводские испытания при трехфазном напряжении 400 В 50 Гц, а цепи управления - при однофазном напряжении 230 В 50 Гц + ноль. При необходимости обеспечить электропитание горелки от сети 230 Вольт 50 Гц без нуля, необходимо выполнить подключения, руководствуясь соответствующей электрической схемой. Линия электроснабжения должна быть оборудована соответствующими предохранителями.

ANOMALIE DI FUNZIONAMENTO / TROUBLESHOOTING ANOMALIES DE FONCTIONNEMENT/ANOMALIAS DE FUNCIONAMIENTO

Il bruciatore non si avvia / The burner does not start / Le brûleur ne démarre pas / El quemador no arranca.

- Interruttore generale in posizione "0"/Main switch in "0"/Interrupteur général en position "0"/ Interruptor general en posición "0".
- Fusibili saltati / Fuses are blown / Fusibles brûlés / Fusibles quemados.
- Termostati caldaia aperti / Boiler thermostats are in open position/Thermostats chaudière ouverts / Termostatos de caldera abiertos.
- Apparecchiatura di controllo difettosa / Control box is defective / Coffret de sécurité défectueux / Equipo de control averiado.

Il bruciatore effettua il prelavaggio, ma non si accende e va in blocco subito dopo. / The burner runs the prepurging but does not ignite and then switches into safety condition / Le brûleur effectue le prebalayage mais ne s'allume pas, par la suite se met en sécurité. / El quemador efectúa el prebarrido pero no se enciende y después se pone en seguridad

- Apparecchiatura di controllo difettosa / Control box is defective / Coffret de sécurité défectueux / Equipo de control averiado.
- Trasformatore difettoso / Ignition transformer is defective / Transformateur défectueux / Transformador averiado.
- Elettrodi sporchi / Electrodes are dirty / Electrodes sales / Electroodos sucios.
- Elettrodi difettosi / Electrodes are defective / Electrodes défectueux / Electroodos averiados.
- Elettrodi in posizione errata / Electrodes are in wrong position / Electrodes en position erronée / Electroodos en posición erronea.
- Ugelli otturati / Nozzles are clogged / Gicleurs bouchés / Inyectores obstruidos.
- Ugelli eccessivamente usurati / Nozzles are too worn / Gicleurs excessivement usés / Inyectores demasiado desgastados.
- Filtri intasati / Filters are clogged / Filtres bouchés / Filtros obstruidos.
- Pressione gasolio troppo bassa / Oil pressure too low / Pression fioul trop faible / Presión del gasóleo demasiado baja.
- Portata d'aria di combustione eccessivamente elevata in rapporto alla portata dell'ugello / Combustion air flow rate excessively high related to nozzle's flow rate / Portée de l'air comburant trop élevée par rapport à la portée du gicleur / Caudal del aire de combustión demasiado alta en relación al caudal del inyector.

Il bruciatore si accende ma va in blocco subito dopo / The burner ignites but then switches into safety condition

Le brûleur s'allume mais se met en de sécurité peu après / El quemador se enciende pero se pone pronto en seguridad

- Apparecchiatura di controllo difettosa / Control box is defective / Coffret de sécurité défectueux / Equipo de control averiado.
- Ugelli otturati / Nozzles are clogged / Gicleurs bouchés / Inyectores obstruidos.
- Ugelli eccessivamente usurati / Nozzles are too worn / Gicleurs excessivement usés / Inyectores demasiado desgastados
- La fotocellula non vede la fiamma / The photocell does not detect the flame / La photocellule n'aperçoit pas la flamme / La fotorresistencia no percibe la llama.
- Filtri intasati / Filters are clogged / Filtres bouchés / Filtros obstruidos.
- Pressione gasolio troppo bassa / Oil pressure too low / Pression fioul trop faible / Presión gasóleo demasiado baja.
- Portata d'aria di combustione eccessivamente elevata in rapporto alla portata dell'ugello / Combustion air flow rate excessively high related to nozzle's flow rate / Portée de l'air comburant trop élevée par rapport à la portée du gicleur / Caudal del aire de combustión demasiado alta en relación al caudal del inyector.

Il bruciatore non passa in 2° stadio / The burner does not switch to High flame

Le brûleur ne passe pas en 2me allure (Haute flamme) / El quemador no entra en la 2a llama (Llama alta).

- Interruttore manuale di 1° e 2° stadio sulla morsettiera in posizione errata / 1st(Low flame) and 2nd (High flame) stage manual switch on control board is in wrong position / Interrupteur manuel de 1re (petite) et 2me (grande) allure sur le tableau de bord en position erronée / Interruptor manual de 1a y 2a llama en el cuadro de mando en posición erronea.
- Apparecchiatura di controllo difettosa / Control box is defective / Coffret de sécurité défectueux / Equipo de control averiado.
- Bobina dell'elettrovalvola 2° stadio difettosa / 2nd stage solenoid valve coil is defective / Bobine de l'électrovanne de 2me allure défectueuse / Bobina de la electroválvula de 2a llama averiada.
- Pressione gasolio troppo bassa / Oil pressure too low / Pression fioul trop faible / Presión del gasóleo demasiado baja.
- Filtri intasati / Filters are clogged / Filtres bouchés / Filtros obstruidos.
- Ugello 2° stadio eccessivamente usurato / 2nd stage nozzle is too worn / Gicleur de 2me allure trop usé / Inyector de 2a llama demasiado desgastado.
- Ugello 2° stadio intasato / 2nd stage nozzle is clogged / Gicleur 2me allure bouché / Inyector de 2a llama obstruido.
- Martinetto serranda aria non tarato o difettoso / Air damper's hydraulic jack not properly adjusted or defective / Vérin hydraulique du clapet de l'air non réglé ou bien défectueux / Mando hidráulico del cierre del aire non regulado o averiado.

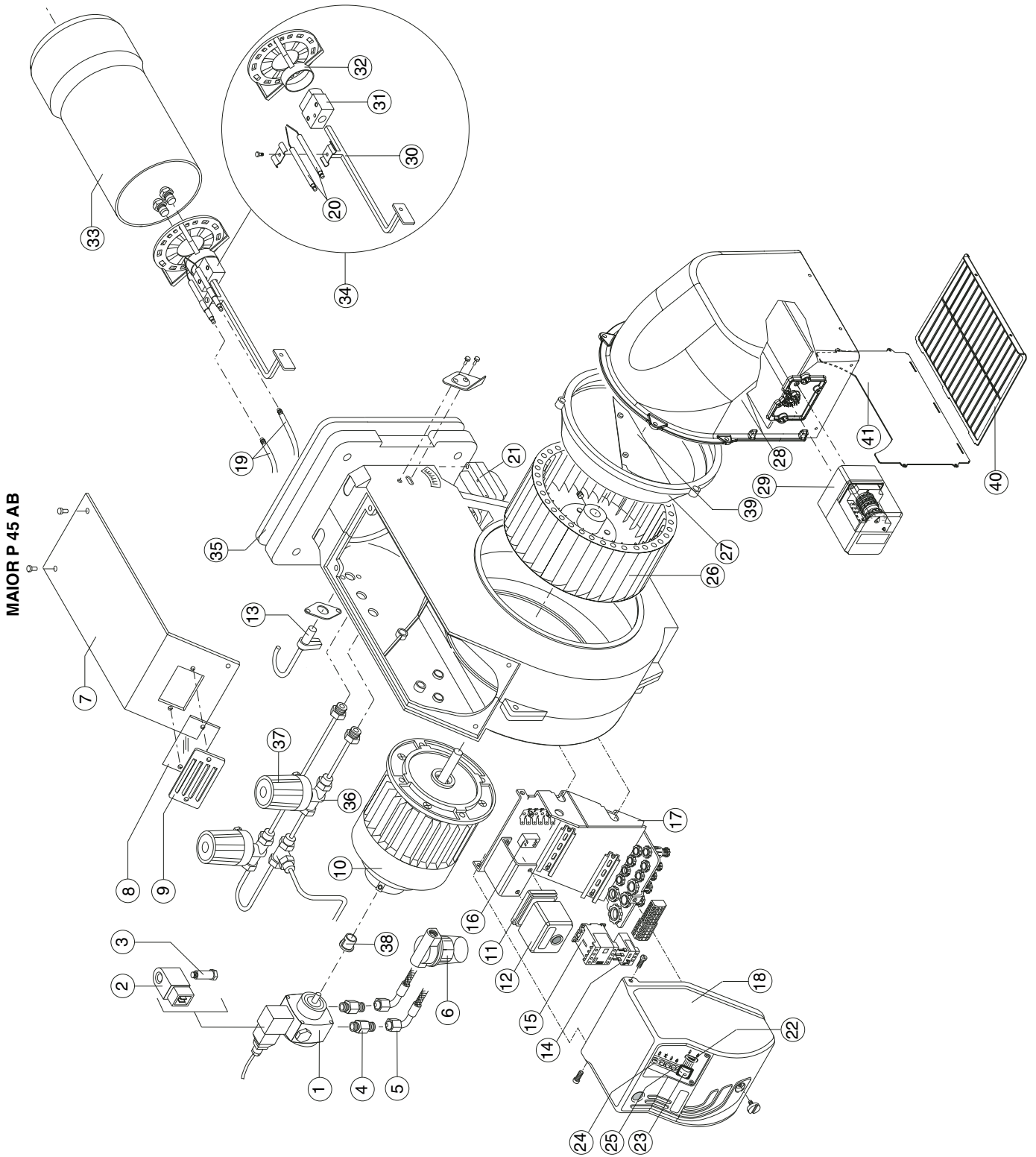

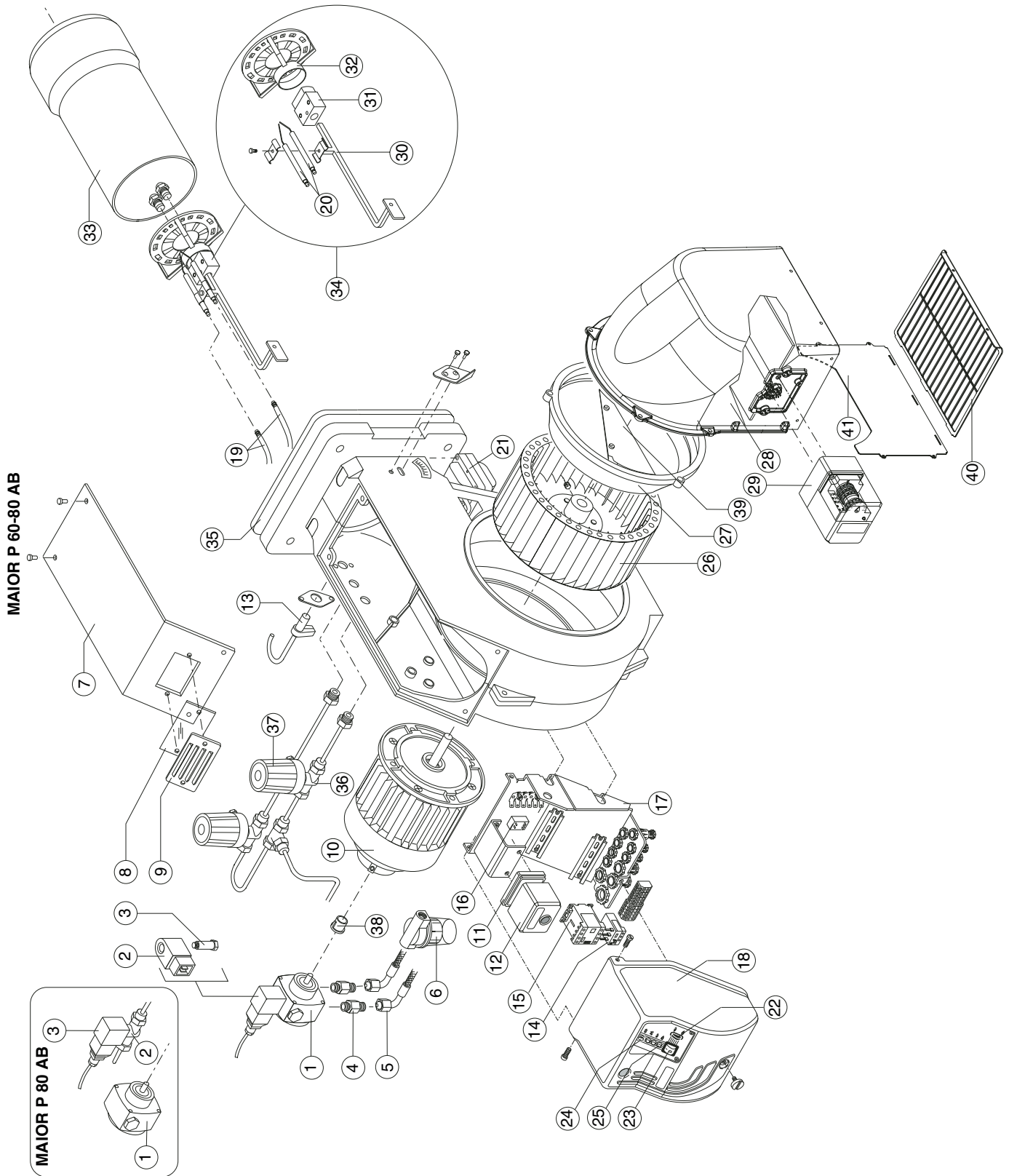

MAIOR P 120 AB

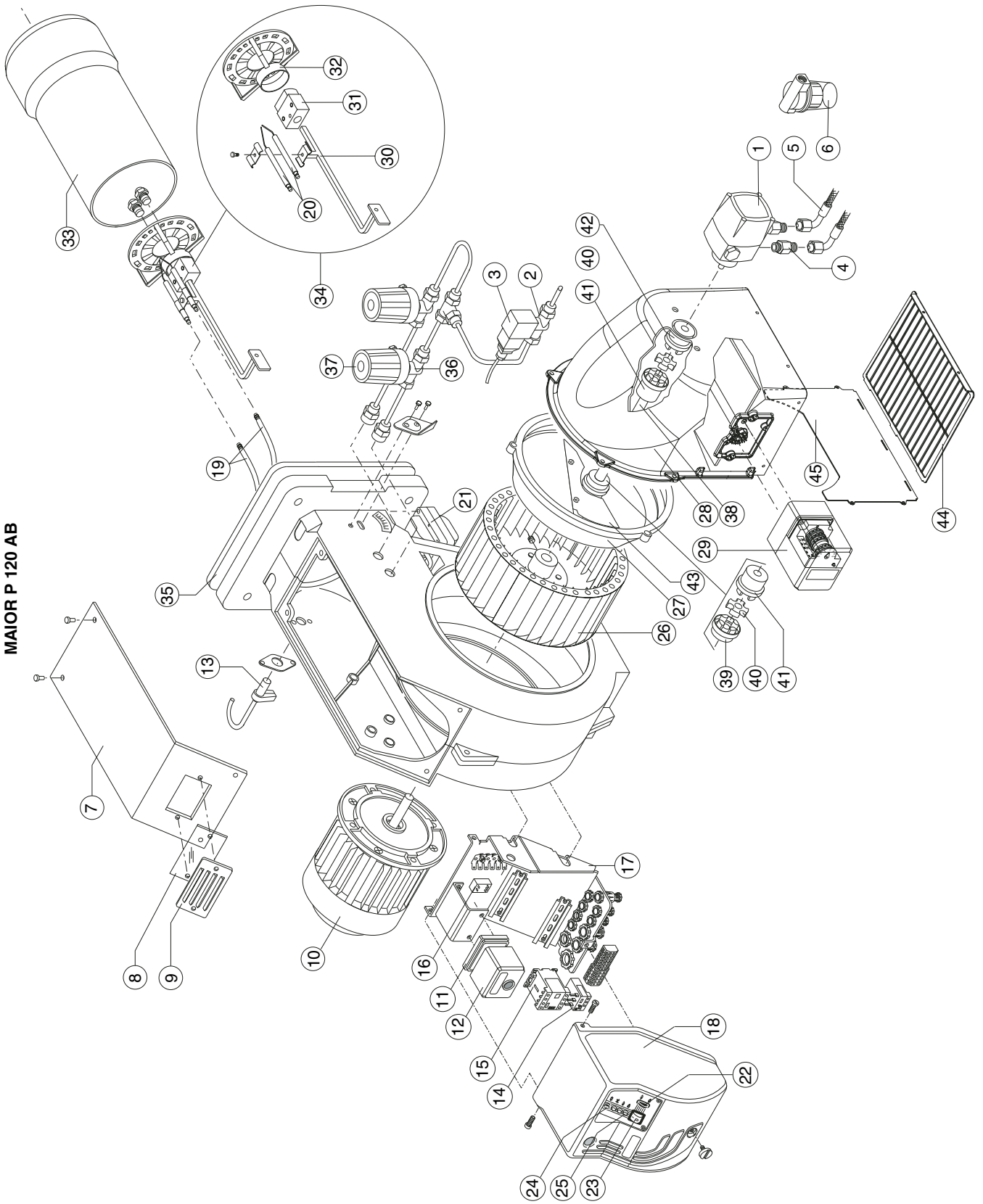

N°	DESCRIZIONE	MAIOR P 45 AB		MAIOR P 60 AB	
			codice		codice
1	- POMPA	SUNTEC AS 67 B	P112	P112	P112
2	- BOBINA	SUNTEC	V504	V504	V504
3	- VALVOLA	SUNTEC	V410	V410	V410
4	- NIPPLE		S905/1	S905/1	S905/1
5	- FLESSIBILI	TN 14x1200	S903/2	S903/2	S903/2
6	- FILTRO	ART.70301-01P	S117/1	S117/1	S117/1
7	- COPERCHIO		BFC09151/038	BFC09151/038	BFC09151/038
8	- VETRINO		BFC02004	BFC02004	BFC02004
9	- SUPPORTO VETRINO		BFC02006	BFC02006	BFC02006
10	- MOTORE	550 W	M169/1	-	-
		740 W	-	M117/1	M117/1
11	- ZOCCOLO APPARECCHIATURA	LANDIS	A402	A402	A402
12	- APPARECCHIATURA DI CONTROLLO	LANDIS LMO44.255A2	A112/2	A112/2	A112/2
13	- FOTORESISTENZA	LANDIS	A207/1	A207/1	A207/1
14	- RELE' TERMICO	AEG 1,7-2,4A	R521/2	-	-
		AEG 2,2-3,2A	-	R521/9	R521/9
15	- TELERUTTORE	AEG LS05.10	R621	R621	R621
16	- FILTRO ANTIDISTURBO		S132/4	S132/4	S132/4
17	- SUPPORTO CASSETTA		BFC01502/017	BFC01502/017	BFC01502/017
18	- CASSETTA		BFC01501	BFC01501	BFC01501
19	- CAVO ACCENSIONE	TC	BFE01402/1	BFE01402/1	BFE01402/1
		TL	BFE01402/2	BFE01402/3	BFE01402/3
20	- ELETTRODO		GREL004/01	GREL004/01	GREL004/01
21	- TRASFORMATORE DI ACCENSIONE	COFI 1020 CM	T105/1	T105/1	T105/1
22	- INTERRUTTORE ALTA-BASSA FIAMMA	cod.360000001	R1020/1	R1020/1	R1020/1
23	- INTERRUTTORE DI LAVORO	cod.40100I1509	R1020	R1020	R1020
24	- PORTA FUSIBILE	Fusit FH-B528	E802/2	E802/2	E802/2
25	- LAMPADA	EL/N-SC4 Elettrospring	E1510	E1510	E1510
26	- VENTOLA	250 x 50	BFV10154/001	-	-
		250 x 84	-	BFV10153/001	BFV10153/001
27	- CONVOGLIATORE		BFC08201/017	BFC08201/017	BFC08201/017
28	- CASSETTO ASPIRAZIONE		BFC04162/038	BFC04162/038	BFC04162/038
29	- MOTORIDUTTORE	SQN S 30.121A2700	M213/1	M213/1	M213/1
30	- ASTINA REGOLAZIONE TESTA	TC	BFA08011/101	BFA08011/301	BFA08011/301
		TL	BFA08011/201	BFA08011/401	BFA08011/401
31	- PORTA UGELLI		BFC11057	BFC11057	BFC11057
32	- DIFFUSORE		BFD05002/151	BFD05016/051	BFD05016/051
33	- BOCCAGLIO	TC	BFB04004/103	BFB05008/121	BFB05008/121
		TL	BFB04011/203	BFB05008/221	BFB05008/221
34	- GRUPPO TESTA	TC	GRTT0100/105	GRTT0100/1182	GRTT0100/1182
		TL	GRTT0100/104	GRTT0100/118	GRTT0100/118
35	- GUARNIZIONE ISOMART		BFG03002/1	BFG03002/2	BFG03002/2
36	- VALVOLA	PARKER	V175/2	V175/2	V175/2
		BRAHMA	-	V402	V402
37	- BOBINA	PARKER	V516/8	V516/8	V516/8
		BRAHMA	-	V501	V501
38	- GIUNTO		MP501/3	MP501/3	MP501/3
39	- SURPRESSORE		BFC08054/001	BFC08054/001	BFC08054/001
40	- PROTEZIONE		BFC04164/001	BFC04164/001	BFC04164/001
41	- LAMIERA DI CHIUSURA		BFC04163/001	BFC04163/001	BFC04163/001

TC = TESTA CORTA TL = TESTA LUNGA

N°	DESCRIZIONE	MAIOR P 80 AB codice
1	- POMPA SUNTEC AN 77 A	P105
2	- BOBINA DELTA	V420
3	- VALVOLA DELTA	V502/2
4	- NIPPLE	S905/1
5	- FLESSIBILI TN 14x1200	S903/2
6	- FILTRO ART.70301-01P	S117/1
7	- COPERCHIO	BFC09151/038
8	- VETRINO	BFC02004
9	- SUPPORTO VETRINO	BFC02006
10	- MOTORE 1100 W	M115/1
11	- ZOCCOLO APPARECCHIATURA LANDIS	A402
12	- APPARECCHIATURA DI CONTROLLO LANDIS LMO44.255A2	A112/2
13	- FOTORESISTENZA LANDIS	A207/1
14	- RELE' TERMICO AEG 3-4,7A	R521/3
15	- TELERUTTORE AEG LS05.10	R621
16	- FILTRO ANTIDISTURBO	S132/4
17	- SUPPORTO CASSETTA	BFC01502/017
18	- CASSETTA	BFC01501
19	- CAVO ACCENSIONE TC	BFE01402/1
	TL	BFE01402/3
20	- ELETTRODO	GREL004/01
21	- TRASFORMATORE DI ACCENSIONE COFI 1020 CM	T105/1
22	- INTERRUTTORE ALTA-BASSA FIAMMA cod.360000001	R1020/1
23	- INTERRUTTORE DI LAVORO cod.40100I1509	R1020
24	- PORTA FUSIBILE Fusit FH-B528	E802/2
25	- LAMPADA EL/N-SC4 Elettrospring	E1510
26	- VENTOLA 260 x 98	BFV10152/001
27	- CONVOGLIATORE	BFC08201/017
28	- CASSETTO ASPIRAZIONE	BFC04162/038
29	- MOTORIDUTTORE SQN S 30.121A2700	M213/1
30	- ASTINA REGOLAZIONE TESTA TC	BFA08011/301
	TL	BFA08011/401
31	- PORTA UGELLI	BFC11057
32	- DIFFUSORE	BFD05016/051
33	- BOCCAGLIO TC	BFB05008/121
	TL	BFB05008/221
34	- GRUPPO TESTA TC	GRTT0100/1182
	TL	GRTT0100/118
35	- GUARNIZIONE ISOMART	BFG03002/3
36	- VALVOLA PARKER	V175/2
37	- BOBINA PARKER	V516/8
38	- GIUNTO	MP501/3
39	- SURPRESSORE	BFC08054/001
40	- PROTEZIONE	BFC04164/001
41	- LAMIERA DI CHIUSURA	BFC04163/001

TC = TESTA CORTA TL = TESTA LUNGA

N°	DESCRIZIONE	MAIOR P 120 AB codice
1	- POMPA SUNTEC AJ 6CC 1000	P103
2	- BOBINA DELTA	V420
3	- VALVOLA DELTA	V502/2
4	- NIPPLE	S905/1
5	- FLESSIBILI TN 14x1200	S903/2
6	- FILTRO ART.70301-01P	S117/1
7	- COPERCHIO	BFC09151/038
8	- VETRINO	BFC02004
9	- SUPPORTO VETRINO	BFC02006
10	- MOTORE 2200 W	M167
11	- ZOCCOLO APPARECCHIATURA LANDIS	A402
12	- APPARECCHIATURA DI CONTROLLO LANDIS LMO44.255A2	A112/2
13	- FOTORESISTENZA LANDIS	A207/1
14	- RELE' TERMICO AEG 4-6,3A	R521/4
15	- TELERUTTORE AEG LS4K.10	R621/1
16	- FILTRO ANTIDISTURBO	S132/4
17	- SUPPORTO CASSETTA	BFC01502/017
18	- CASSETTA	BFC01501
19	- CAVO ACCENSIONE TC	BFE01402/1
	TL	BFE01402/3
20	- ELETTRODO	GREL004/01
21	- TRASFORMATORE DI ACCENSIONE COFI 1020 CM	T105/1
22	- INTERRUTTORE ALTA-BASSA FIAMMA cod.360000001	R1020/1
23	- INTERRUTTORE DI LAVORO cod.4010011509	R1020
24	- PORTA FUSIBILE Fusit FH-B528	E802/2
25	- LAMPADA EL/N-SC4 Elettrospring	E1510
26	- VENTOLA 260 x 110	BFV10151/001
27	- CONVOGLIATORE	BFC08201/017
28	- CASSETTO ASPIRAZIONE	BFC04165/038
29	- MOTORIDUTTORE SQN S 30.121A2700	M213/1
30	- ASTINA REGOLAZIONE TESTA TC	BFA08011/101
	TL	BFA08011/201
31	- PORTA UGELLI	BFC11057
32	- DIFFUSORE	BFD05004/051
33	- BOCCAGLIO TC	BFB05003/121
	TL	BFB05003/221
34	- GRUPPO TESTA TC	GRTT0100/1242
	TL	GRTT0100/124
35	- GUARNIZIONE ISOMART	BFG03002/3
36	- VALVOLA PARKER	V175/2
37	- BOBINA PARKER	V516/8
38	- PERNO	BFT05104/101
39	- GIUNTO VENTOLA	BFV10201/4
40	- GIUNTO GOMMA	BFV10201/6
41	- GIUNTO INTERMEDIO	BFV10201/1
42	- GIUNTO POMPA	BFV10201/2
43	- SURPRESSORE	BFC08053/001
44	- PROTEZIONE	BFC04164/001
45	- LAMIERA DI CHIUSURA	BFC04163/001

TC = TESTA CORTA TL = TESTA LUNGA

N°	DESCRIPTION	MAIOR P 45 AB		MAIOR P 60 AB	
			code		code
1	- OIL PUMP	SUNTEC AS 67 B	P112	P112	P112
2	- COIL	SUNTEC	V504	V504	V504
3	- OIL VALVE	SUNTEC	V410	V410	V410
4	- NIPPLE		S905/1	S905/1	S905/1
5	- HOSES	TN 14x1200	S903/2	S903/2	S903/2
6	- FILTER	ART.70301-01P	S117/1	S117/1	S117/1
7	- COVER		BFC09151/038	BFC09151/038	BFC09151/038
8	- GLASS		BFC02004	BFC02004	BFC02004
9	- VIEWING WINDOW		BFC02006	BFC02006	BFC02006
10	- MOTOR	550 W	M169/1	-	-
		740 W	-	M117/1	M117/1
11	- CONTROL BOX BASE	LANDIS	A402	A402	A402
12	- CONTROL BOX	LANDIS LMO44.255A2	A112/2	A112/2	A112/2
13	- PHOTORESISTOR	LANDIS	A207/1	A207/1	A207/1
14	- MOTOR THERMAL RELAY	AEG 1,7-2,4A	R521/2	-	-
		AEG 2,2-3,2A	-	R521/9	R521/9
15	- REMOTE CONTROL SWITCH	AEG LS05.10	R621	R621	R621
16	- ANTIJAMMING FILTER		S132/4	S132/4	S132/4
17	- BOX SUPPORT		BFC01502/017	BFC01502/017	BFC01502/017
18	- BOX		BFC01501	BFC01501	BFC01501
19	- CABLE	TC	BFE01402/1	BFE01402/1	BFE01402/1
		TL	BFE01402/2	BFE01402/3	BFE01402/3
20	- ELECTRODES		GREL004/01	GREL004/01	GREL004/01
21	- IGNITION TRANSFORMER	COFI 1020 CM	T105/1	T105/1	T105/1
22	- HIGH-LOW FLAME SWITCH	cod.360000001	R1020/1	R1020/1	R1020/1
23	- MAIN SWITCH	cod.40100I1509	R1020	R1020	R1020
24	- FUSE HOLDER	Fusit FH-B528	E802/2	E802/2	E802/2
25	- LAMP	EL/N-SC4 Elettrospring	E1510	E1510	E1510
26	- FAN	250 x 50	BFV10154/001	-	-
		250 x 84	-	BFV10153/001	BFV10153/001
27	- AIR CONVEYOR		BFC08201/017	BFC08201/017	BFC08201/017
28	- COVER AIR INLET		BFC04162/038	BFC04162/038	BFC04162/038
29	- AIR DAMPER MOTOR	SQN S 30.121A2700	M213/1	M213/1	M213/1
30	- ROD	TC	BFA08011/101	BFA08011/301	BFA08011/301
		TL	BFA08011/201	BFA08011/401	BFA08011/401
31	- NOZZLE HOLDER		BFC11057	BFC11057	BFC11057
32	- DIFFUSER		BFD05002/151	BFD05016/051	BFD05016/051
33	- BLAST TUBE	TC	BFB04004/103	BFB05008/121	BFB05008/121
		TL	BFB04011/203	BFB05008/221	BFB05008/221
34	- INNER ASSEMBLY	TC	GRTT0100/105	GRTT0100/1182	GRTT0100/1182
		TL	GRTT0100/104	GRTT0100/118	GRTT0100/118
35	- GASKET		BFG03002/1	BFG03002/2	BFG03002/2
36	- OIL VALVE	PARKER	V175/2	V175/2	V175/2
		BRAHMA	-	V402	V402
37	- COIL	PARKER	V516/8	V516/8	V516/8
		BRAHMA	-	V501	V501
38	- COUPLING		MP501/3	MP501/3	MP501/3
39	- FAN SCOOP		BFC08054/001	BFC08054/001	BFC08054/001
40	- PROTECTION		BFC04164/001	BFC04164/001	BFC04164/001
41	- SHEET CLOSING		BFC04163/001	BFC04163/001	BFC04163/001

TC = SHORT HEAD TL = LONG HEAD

N°	DESCRIPTION	MAIOR P 80 AB code
1	- OIL PUMP SUNTEC AN 77 A	P105
2	- COIL DELTA	V420
3	- OIL VALVE DELTA	V502/2
4	- NIPPLE	S905/1
5	- HOSES TN 14x1200	S903/2
6	- FILTER ART.70301-01P	S117/1
7	- COVER	BFC09151/038
8	- GLASS	BFC02004
9	- VIEWING WINDOW	BFC02006
10	- MOTOR 1100 W	M115/1
11	- CONTROL BOX BASE LANDIS	A402
12	- CONTROL BOX LANDIS LMO44.255A2	A112/2
13	- PHOTORESISTOR LANDIS	A207/1
14	- MOTOR THERMAL RELAY AEG 3-4,7A	R521/3
15	- REMOTE CONTROL SWITCH AEG LS05.10	R621
16	- ANTIJAMMING FILTER	S132/4
17	- BOX SUPPORT	BFC01502/017
18	- BOX	BFC01501
19	- CABLE TC	BFE01402/1
	TL	BFE01402/3
20	- ELECTRODES	GREL004/01
21	- IGNITION TRANSFORMER COFI 1020 CM	T105/1
22	- HIGH-LOW FLAME SWITCH cod.360000001	R1020/1
23	- MAIN SWITCH cod.40100I1509	R1020
24	- FUSE HOLDER Fusit FH-B528	E802/2
25	- LAMP EL/N-SC4 Elettrospring	E1510
26	- FAN 260 x 98	BFV10152/001
27	- AIR CONVEYOR	BFC08201/017
28	- COVER AIR INLET	BFC04162/038
29	- AIR DAMPER MOTOR SQN S 30.121A2700	M213/1
30	- ROD TC	BFA08011/301
	TL	BFA08011/401
31	- NOZZLE HOLDER	BFC11057
32	- DIFFUSER	BFD05016/051
33	- BLAST TUBE TC	BFB05008/121
	TL	BFB05008/221
34	- INNER ASSEMBLY TC	GRTT0100/1182
	TL	GRTT0100/118
35	- GASKET	BFG03002/3
36	- OIL VALVE PARKER	V175/2
37	- COIL PARKER	V516/8
38	- COUPLING	MP501/3
39	- FAN SCOOP	BFC08054/001
40	- PROTECTION	BFC04164/001
41	- SHEET CLOSING	BFC04163/001

TC = SHORT HEAD TL = LONG HEAD

N°	DESCRIPTION	MAIOR P 120 AB code
1	- OIL PUMP SUNTEC AJ 6CC 1000	P103
2	- COIL DELTA	V420
3	- OIL VALVE DELTA	V502/2
4	- NIPPLE	S905/1
5	- HOSES TN 14x1200	S903/2
6	- FILTER ART.70301-01P	S117/1
7	- COVER	BFC09151/038
8	- GLASS	BFC02004
9	- VIEWING WINDOW	BFC02006
10	- MOTOR 2200 W	M167
11	- CONTROL BOX BASE LANDIS	A402
12	- CONTROL BOX LANDIS LMO44.255A2	A112/2
13	- PHOTORESISTOR LANDIS	A207/1
14	- MOTOR THERMAL RELAY AEG 4-6,3A	R521/4
15	- REMOTE CONTROL SWITCH AEG LS4K.10	R621/1
16	- ANTIJAMMING FILTER	S132/4
17	- BOX SUPPORT	BFC01502/017
18	- BOX	BFC01501
19	- CABLE TC	BFE01402/1
	TL	BFE01402/3
20	- ELECTRODES	GREL004/01
21	- IGNITION TRANSFORMER COFI 1020 CM	T105/1
22	- HIGH-LOW FLAME SWITCH cod.360000001	R1020/1
23	- MAIN SWITCH cod.40100I1509	R1020
24	- FUSE HOLDER Fusit FH-B528	E802/2
25	- LAMP EL/N-SC4 Elettrospring	E1510
26	- FAN 260 x 110	BFV10151/001
27	- AIR CONVEYOR	BFC08201/017
28	- COVER AIR INLET	BFC04165/038
29	- AIR DAMPER MOTOR SQN S 30.121A2700	M213/1
30	- ROD TC	BFA08011/101
	TL	BFA08011/201
31	- NOZZLE HOLDER	BFC11057
32	- DIFFUSER	BFD05004/051
33	- BLAST TUBE TC	BFB05003/121
	TL	BFB05003/221
34	- INNER ASSEMBLY TC	GRTT0100/1242
	TL	GRTT0100/124
35	- GASKET	BFG03002/3
36	- OIL VALVE PARKER	V175/2
37	- COIL PARKER	V516/8
38	- ROD	BFT05104/101
39	- COUPLING (FAN)	BFV10201/4
40	- UNION	BFV10201/6
41	- COUPLING	BFV10201/1
42	- COUPLING (PUMP)	BFV10201/2
43	- FAN SCOOP	BFC08053/001
44	- PROTECTION	BFC04164/001
45	- SHEET CLOSING	BFC04163/001

TC = SHORT HEAD TL = LONG HEAD

N°	DESIGNATION	MAIOR P 45 AB		MAIOR P 60 AB	
			code		code
1	- POMPE	SUNTEC AS 67 B	P112	P112	P112
2	- BOBINE	SUNTEC	V504	V504	V504
3	- VANNE	SUNTEC	V410	V410	V410
4	- MAMELONS		S905/1	S905/1	S905/1
5	- FLEXIBLES	TN 14x1200	S903/2	S903/2	S903/2
6	- FILTRE	ART.70301-01P	S117/1	S117/1	S117/1
7	- COUVERCHE DE BRULEUR		BFC09151/038	BFC09151/038	BFC09151/038
8	- HUBLOT		BFC02004	BFC02004	BFC02004
9	- PROTECTION HUBLOT		BFC02006	BFC02006	BFC02006
10	- MOTEUR	550 W	M169/1	-	-
		740 W	-	M117/1	M117/1
11	- SOCLE DE COFFRET	LANDIS	A402	A402	A402
12	- COFFRET DE SECURITE	LANDIS LMO44.255A2	A112/2	A112/2	A112/2
13	- CELLULE	LANDIS	A207/1	A207/1	A207/1
14	- RELAIS THERMIQUE	AEG 1,7-2,4A	R521/2	-	-
		AEG 2,2-3,2A	-	R521/9	R521/9
15	- TELERUPTEUR	AEG LS05.10	R621	R621	R621
16	- FILTRE ANTIPARASITE		S132/4	S132/4	S132/4
17	- SUPPORT		BFC01502/017	BFC01502/017	BFC01502/017
18	- CAUVERCLE		BFC01501	BFC01501	BFC01501
19	- CABLE	TC	BFE01402/1	BFE01402/1	BFE01402/1
		TL	BFE01402/2	BFE01402/3	BFE01402/3
20	- ELECTRODE D'ALLUMAGE		GREL004/01	GREL004/01	GREL004/01
21	- TRANSFORMATEUR	COFI 1020 CM	T105/1	T105/1	T105/1
22	- INTERRUPTEUR GRANDE/PETITE ALLURE	cod.360000001	R1020/1	R1020/1	R1020/1
23	- INTERRUPTEUR DE LIGNE	cod.40100I1509	R1020	R1020	R1020
24	- PORTE FUSIBLE	Fusit FH-B528	E802/2	E802/2	E802/2
25	- LAMPE	EL/N-SC4 Elettrospring	E1510	E1510	E1510
26	- TURBINE	250 x 50	BFV10154/001	-	-
		250 x 84	-	BFV10153/001	BFV10153/001
27	- CONVOYEUR D'AIR		BFC08201/017	BFC08201/017	BFC08201/017
28	- BOITE D'AIR		BFC04162/038	BFC04162/038	BFC04162/038
29	- SERVOMOTEUR	SQN S 30.121A2700	M213/1	M213/1	M213/1
30	- SUPPORT TETE DE COMBUSTION	TC	BFA08011/101	BFA08011/301	BFA08011/301
		TL	BFA08011/201	BFA08011/401	BFA08011/401
31	- PORTE GICLEUR		BFC11057	BFC11057	BFC11057
32	- DEFLECTEUR		BFD05002/151	BFD05016/051	BFD05016/051
33	- GUEULARD	TC	BFB04004/103	BFB05008/121	BFB05008/121
		TL	BFB04011/203	BFB05008/221	BFB05008/221
34	- TETE DE COMBUSTION	TC	GRTT0100/105	GRTT0100/1182	GRTT0100/1182
		TL	GRTT0100/104	GRTT0100/118	GRTT0100/118
35	- JOINT		BFG03002/1	BFG03002/2	BFG03002/2
36	- VANNE	PARKER	V175/2	V175/2	V175/2
		BRAHMA	-	V402	V402
37	- BOBINE	PARKER	V516/8	V516/8	V516/8
		BRAHMA	-	V501	V501
38	- JOINT D'ACCOUPLLEMENT		MP501/3	MP501/3	MP501/3
39	- SURPRESSEUR		BFC08054/001	BFC08054/001	BFC08054/001
40	- PROTECTION		BFC04164/001	BFC04164/001	BFC04164/001
41	- FEUILLE FERMANTE		BFC04163/001	BFC04163/001	BFC04163/001

TC = TETE COURTE TL = TETE LONGUE

FR

N°	DESIGNATION	MAIOR P 80 AB code
1	- POMPE SUNTEC AN 77 A	P105
2	- BOBINE DELTA	V420
3	- VANNE DELTA	V502/2
4	- MAMELONS	S905/1
5	- FLEXIBLES TN 14x1200	S903/2
6	- FILTRE ART.70301-01P	S117/1
7	- COUVERCHE DE BRULEUR	BFC09151/038
8	- HUBLLOT	BFC02004
9	- PROTECTION HUBLLOT	BFC02006
10	- MOTEUR 1100 W	M115/1
11	- SOCLE DE COFFRET LANDIS LMO44.255A2	A112/2
12	- COFFRET DE SECURITE LANDIS LOA 44	A120
13	- CELLULE LANDIS	A207/1
14	- RELAIS THERMIQUE AEG 3-4,7A	R521/3
15	- TELERUPTEUR AEG LS05.10	R621
16	- FILTRE ANTIPARASITE	S132/4
17	- SUPPORT	BFC01502/017
18	- CAUVERCLE	BFC01501
19	- CABLE TC	BFE01402/1
	TL	BFE01402/3
20	- ELECTRODE D'ALLUMAGE	GREL004/01
21	- TRANSFORMATEUR COFI 1020 CM	T105/1
22	- INTERRUPTEUR GRANDE/PETITE ALLURE cod.360000001	R1020/1
23	- INTERRUPTEUR DE LIGNE cod.4010011509	R1020
24	- PORTE FUSIBLE Fusit FH-B528	E802/2
25	- LAMPE EL/N-SC4 Elettrospring	E1510
26	- TURBINE 260 x 98	BFV10152/001
27	- CONVOYEUR D'AIR	BFC08201/017
28	- BOITE D'AIR	BFC04162/038
29	- SERVOMOTEUR SQN S 30.121A2700	M213/1
30	- SUPPORT TETE DE COMBUSTION TC	BFA08011/301
	TL	BFA08011/401
31	- PORTE GICLEUR	BFC11057
32	- DEFLECTEUR	BFD05016/051
33	- GUEULARD TC	BFB05008/121
	TL	BFB05008/221
34	- TETE DE COMBUSTION TC	GRTT0100/1182
	TL	GRTT0100/118
35	- JOINT	BFG03002/3
36	- VANNE PARKER	V175/2
37	- BOBINE PARKER	V516/8
38	- JOINT D'ACCOUPEMENT	MP501/3
39	- SURPRESSEUR	BFC08054/001
40	- PROTECTION	BFC04164/001
41	- FEUILLE FERMANTE	BFC04163/001

TC = TETE COURTE TL = TETE LONGUE

N°	DESIGNATION	MAIOR P 120 AB code
1	- POMPE SUNTEC AJ 6CC 1000	P103
2	- BOBINE DELTA	V420
3	- VANNE DELTA	V502/2
4	- MAMELONS	S905/1
5	- FLEXIBLES TN 14x1200	S903/2
6	- FILTRE ART.70301-01P	S117/1
7	- COUVERCHE DE BRULEUR	BFC09151/038
8	- HUBLLOT	BFC02004
9	- PROTECTION HUBLLOT	BFC02006
10	- MOTEUR 2200 W	M167
11	- SOCLE DE COFFRET LANDIS	A402
12	- COFFRET DE SECURITE LANDIS LMO44.255A2	A112/2
13	- CELLULE LANDIS	A207/1
14	- RELAIS THERMIQUE AEG 4-6,3A	R521/4
15	- TELERUPTEUR AEG LS4K.10	R621/1
16	- FILTRE ANTIPARASITE	S132/4
17	- SUPPORT	BFC01502/017
18	- CAUVERCLE	BFC01501
19	- CABLE TC	BFE01402/1
	TL	BFE01402/3
20	- ELECTRODE D'ALLUMAGE	GREL004/01
21	- TRANSFORMATEUR COFI 1020 CM	T105/1
22	- INTERRUPTEUR GRANDE/PETITE ALLURE cod.360000001	R1020/1
23	- INTERRUPTEUR DE LIGNE cod.40100I1509	R1020
24	- PORTE FUSIBLE Fusit FH-B528	E802/2
25	- LAMPE EL/N-SC4 Elettrospring	E1510
26	- TURBINE 260 x 110	BFV10151/001
27	- CONVOYEUR D'AIR	BFC08201/017
28	- BOITE D'AIR	BFC04165/038
29	- SERVOMOTEUR SQN S 30.121A2700	M213/1
30	- SUPPORT TETE DE COMBUSTION TC	BFA08011/101
	TL	BFA08011/201
31	- PORTE GICLEUR	BFC11057
32	- DEFLECTEUR	BFD05004/051
33	- GUEULARD TC	BFB05003/121
	TL	BFB05003/221
34	- TETE DE COMBUSTION TC	GRTT0100/1242
	TL	GRTT0100/124
35	- JOINT	BFG03002/3
36	- VANNE PARKER	V175/2
37	- BOBINE PARKER	V516/8
38	- ARBRE DE TRASMISSION	BFT05104/101
39	- JOINT DU VENTILATEUR	BFV10201/4
40	- JOINT DE CAOUTCHOUC	BFV10201/6
41	- JOINT	BFV10201/1
42	- JOINT DE LA POMPE	BFV10201/2
43	- SURPRESSEUR	BFC08053/001
44	- PROTECTION	BFC04164/001
45	- FEUILLE FERMANTE	BFC04163/001

ES

N°	DESCRIPCION	MAIOR P 45 AB	MAIOR P 60 AB
		código	código
1	- BOMBA	SUNTEC AS 67 B	P112
2	- BOBINA	SUNTEC	V504
3	- VÁLVULA	SUNTEC	V410
4	- TUERCA		S905/1
5	- LATIGUILLOS	TN 14x1200	S903/2
6	- FILTRO	ART.70301-01P	S117/1
7	- TAPA		BFC09151/038
8	- VIDRIOSOS		BFC02004
9	- SOPORTE VIDRIOSOS		BFC02006
10	- MOTOR	550 W	M169/1
		740 W	-
			M117/1
11	- BASE DEL EQUIPO	LANDIS	A402
12	- EQUIPO CONTROL LLAMA	LANDIS LMO44.255A2	A112/2
13	- FOTORRESISTENCIA	LANDIS	A207/1
14	- TERMICO	AEG 1,7-2,4A	R521/2
		AEG 2,2-3,2A	-
			R521/9
15	- TELERRUPTOR	AEG LS05.10	R621
16	- FILTRO ANTITRATORNO		S132/4
17	- SOPORTE		BFC01502/017
18	- CAJA DE PROTECCIÓN		BFC01501
19	- CABLE	TC	BFE01402/1
		TL	BFE01402/2
			BFE01402/3
20	- ELECTRODO		GREL004/01
21	- TRANSFORMADOR	COFI 1020 CM	T105/1
22	- INTERRUPTOR DE ALTA/BAJA LLAMA	cod.360000001	R1020/1
23	- INTERRUPTOR DE LINEA	cod.40100I1509	R1020
24	- SOPORTE FUSIBLE	Fusit FH-B528	E802/2
25	- ESPIA	EL/N-SC4 Elettrospring	E1510
26	- VENTILADOR	250 x 50	BFV10154/001
		250 x 84	-
			BFV10153/001
27	- REJILLA DEFLECTORA		BFC08201/017
28	- CIERRE EN ASPIRACIÓN		BFC04162/038
29	- SISTEMA HIDRÁULICO	SQN S 30.121A2700	M213/1
30	- SOPORTE PORTAINYECTOR	TC	BFA08011/101
		TL	BFA08011/201
			BFA08011/301
			BFA08011/401
31	- PORTAINYECTOR		BFC11057
32	- DIFUSOR		BFD05002/151
			BFD05016/051
33	- TUBO LLAMA	TC	BFB04004/103
		TL	BFB04011/203
			BFB05008/121
			BFB05008/221
34	- GRUPO CABEZA DE COMBUSTION	TC	GRTT0100/105
		TL	GRTT0100/104
			GRTT0100/1182
			GRTT0100/118
35	- JUNTA		BFG03002/1
			BFG03002/2
36	- VÁLVULA	PARKER	V175/2
		BRAHMA	-
			V402
37	- BOBINA	PARKER	V516/8
		BRAHMA	-
			V501
38	- ACOPLAMIENTO		MP501/3
39	- SURPRESSORE		BFC08054/001
40	- PROTECCION		BFC04164/001
41	- HOJA CERRADA		BFC04163/001

TC = CABEZA CORTA TL = CABEZA LARGA

N°	DESCRIPCION	MAIOR P 80 AB código
1	- BOMBA SUNTEC AN 77 A	P105
2	- BOBINA DELTA	V420
3	- VÁLVULA DELTA	V502/2
4	- TUERCA	S905/1
5	- LATIGUILLOS TN 14x1200	S903/2
6	- FILTRO ART.70301-01P	S117/1
7	- TAPA	BFC09151/038
8	- VIDRIOSO	BFC02004
9	- SOPORTE VIDRIOSO	BFC02006
10	- MOTOR 1100 W	M115/1
11	- BASE DEL EQUIPO LANDIS	A402
12	- EQUIPO CONTROL LLAMA LANDIS LMO44.255A2	A112/2
13	- FOTORRESISTENCIA LANDIS	A207/1
14	- TERMICO AEG 3-4,7A	R521/3
15	- TELERRUPTOR AEG LS05.10	R621
16	- FILTRO ANTITRASTORNO	S132/4
17	- SOPORTE	BFC01502/017
18	- CAJA DE PROTECCIÓN	BFC01501
19	- CABLE TC	BFE01402/1
	TL	BFE01402/3
20	- ELECTRODO	GREL004/01
21	- TRANSFORMADOR COFI 1020 CM	T105/1
22	- INTERRUPTOR DE ALTA/BAJA LLAMA cod.360000001	R1020/1
23	- INTERRUPTOR DE LINEA cod.40100I1509	R1020
24	- SOPORTE FUSIBLE Fusit FH-B528	E802/2
25	- ESPIA EL/N-SC4 Elettrospring	E1510
26	- VENTILADOR 260 x 98	BFV10152/001
27	- REJILLA DEFLECTORA	BFC08201/017
28	- CIERRE EN ASPIRACIÓN	BFC04162/038
29	- SISTEMA HIDRÁULICO SQN S 30.121A2700	M213/1
30	- SOPORTE PORTAINYECTOR TC	BFA08011/301
	TL	BFA08011/401
31	- PORTAINYECTOR	BFC11057
32	- DIFUSOR	BFD05016/051
33	- TUBO LLAMA TC	BFB05008/121
	TL	BFB05008/221
34	- GRUPO CABEZA DE COMBUSTION TC	GRTT0100/1182
	TL	GRTT0100/118
35	- JUNTA	BFG03002/3
36	- VÁLVULA PARKER	V175/2
37	- BOBINA PARKER	V516/8
38	- ACOPLAMIENTO	MP501/3
39	- SURPRESSORE	BFC08054/001
40	- PROTECCION	BFC04164/001
41	- HOJA CERRADA	BFC04163/001

TC = CABEZA CORTA TL = CABEZA LARGA

ES

N°	DESCRIPCION	MAIOR P 120 AB código
1	- BOMBA SUNTEC AJ 6CC 1000	P103
2	- BOBINA DELTA	V420
3	- VÁLVULA DELTA	V502/2
4	- TUERCA	S905/1
5	- LATIGUILLOS TN 14x1200	S903/2
6	- FILTRO ART.70301-01P	S117/1
7	- TAPA	BFC09151/038
8	- VIDRIOSO	BFC02004
9	- SOPORTE VIDRIOSO	BFC02006
10	- MOTOR 2200 W	M167
11	- BASE DEL EQUIPO LANDIS	A402
12	- EQUIPO CONTROL LLAMA LANDIS LMO44,255A2	A112/2
13	- FOTORRESISTENCIA LANDIS	A207/1
14	- TERMICO AEG 4-6,3A	R521/4
15	- TELERRUPTOR AEG LS4K.10	R621/1
16	- FILTRO ANTITRATORNO	S132/4
17	- SOPORTE	BFC01502/017
18	- CAJA DE PROTECCIÓN	BFC01501
19	- CABLE TC	BFE01402/1
	TL	BFE01402/3
20	- ELECTRODO	GREL004/01
21	- TRANSFORMADOR COFI 1020 CM	T105/1
22	- INTERRUPTOR DE ALTA/BAJA LLAMA cod.360000001	R1020/1
23	- INTERRUPTOR DE LINEA cod.4010011509	R1020
24	- SOPORTE FUSIBLE Fusit FH-B528	E802/2
25	- ESPIA EL/N-SC4 Elettrospring	E1510
26	- VENTILADOR 260 x 110	BFV10151/001
27	- REJILLA DEFLECTORA	BFC08201/017
28	- CIERRE EN ASPIRACIÓN	BFC04165/038
29	- SISTEMA HIDRÁULICO SQN S 30.121A2700	M213/1
30	- SOPORTE PORTAINYECTOR TC	BFA08011/101
	TL	BFA08011/201
31	- PORTAINYECTOR	BFC11057
32	- DIFUSOR	BFD05004/051
33	- TUBO LLAMA TC	BFB05003/121
	TL	BFB05003/221
34	- GRUPO CABEZA DE COMBUSTION TC	GRTT0100/1242
	TL	GRTT0100/124
35	- JUNTA	BFG03002/3
36	- VÁLVULA PARKER	V175/2
37	- BOBINA PARKER	V516/8
38	- SOPORTE	BFT05104/101
39	- ACOPLAMIENTO VENTILADOR	BFV10201/4
40	- ACOPLAMIENTO GOMA	BFV10201/6
41	- ACOPLAMIENTO INTERMEDIO	BFV10201/1
42	- ACOPLAMIENTO BOMBA	BFV10201/2
43	- SURPRESSORE	BFC08053/001
44	- PROTECCION	BFC04164/001
45	- HOJA CERRADA	BFC04163/001

TC = CABEZA CORTA TL = CABEZA LARGA

La ECOFLAM BRUCIATORI S.p.A si riserva il diritto di apportare ai prodotti quelle modifiche che riterrà necessarie o utili, senza pregiudicarne le caratteristiche principali.

ECOFLAM BRUCIATORI S.p.A. reserves the right to make any adjustments, without prior notice, which it considers necessary or useful to its products, without affecting their main features.

La Maison ECOFLAM BRUCIATORI S.p.A. se réserve le droit d'apporter les modifications qu'elle jugera nécessaires ou utiles à ses produits sans pour autant nuire à leurs caractéristiques principales.

ECOFLAM BRUCIATORI S.p.A. se reserva el derecho a introducir en sus productos todas las modificaciones que considere necesarias o utiles, sin perjudicar sus características.

“Экофлам С.п.А.” оставляет за собой право вносить в конструкцию оборудования любые необходимые изменения без особого предупреждения.

Ecoflam

Ecoflam Bruciatori S.p.A.

via Roma, 64 - 31023 RESANA (TV) - Italy - tel. 0423.719500 - fax 0423.719580

<http://www.ecoflam-burners.com> - e-mail: export@ecoflam-burners.com

"società soggetta alla direzione e al coordinamento della Ariston Thermo S.p.A., via A. Merloni, 45 - 60044 Fabriano (An) CF 01026940427"