

INSTALLATION AND SERVICE MANUAL



Free Cooling direct expansion
terminal units

HED-HCAT SE
0011-0021-0031
0041-0051-0056 -0061

FREE COOLING
Standard &
Silented version



INDOOR UNIT

U	I	A	General warnings	2
U	I	A	Fundamental safety rules	2
U	I	A	Identification	3
U	I	A	Receiving and handling the product	3
	I	A	Description of standard unit	4
	I		Dimensional drawings	6
	I		Installation	6
	I		Functional distances	6
	I	A	Refrigerant pipe connection	8
	I	A	Refrigerant circuit	8
	I	A	Electrical connections	8
	I	A	Heater positioning	9
	I	A	Technical data	9
	I	A	Routine maintenance	10
		A	Seasonal maintenance	10
U	I	A	Layout quadro elettrico	11
	I	A	Electrical wiring diagram HED 0021	12
	I	A	Electrical wiring diagram HED 0041	13

OUTDOOR UNIT

I	A	Identification	14	
I	A	Receiving and handling the product	14	
I	A	Standard unit description HCAT	15	
	I	Dimensional drawings	16	
	I	Installation	17	
	I	A	Refrigerant pipe connection	17
	I	A	Sizing of refrigerant pipes	19
	I	A	Electrical connection	21
	I	A	Operating limits	22
	I	A	Checking and starting up the unit	22
	I	A	Unit type configuration	24
	I	A	Unit controller	25
	I	A	Control and display parameters	26
	I	A	pLAN Network set-Up	38
	I	A	Addressing and management of connections between Boards (pLAN)	38
	I	A	pLAN Software configuration	39
U	I	A	Troubleshooting	41

The following symbols have been used in some parts of this booklet and inside the appliance:



User



Attention



Danger. live parts



Installer



Forbidden



Danger. moving blades



After-sales service

 **HED SE FC terminal units** are the internal units of a "split" two section system. Combined with a **HCAT SE** condenser unit, they form a combined air conditioning and heating system. Incorrect installation, regulation and maintenance, improper use or installation by unqualified personnel absolves the **manufacturer** from all liability, whether contractual or otherwise, for damage to people, animals or things. Only those applications specifically indicated in this list are permitted.

Read this manual carefully. All work must be carried out by qualified personnel in conformity with legislation in force in the country concerned.

The guarantee is invalidated if the above instructions are not respected and if the unit is started up for the first time without the presence of personnel authorised by the Company (where specified in the supply contract) who should draw up a "start-up report".

The documentation supplied with the unit must be consigned to the owner who should keep it carefully for future consultation.

When the items are consigned by the transporter, check that the packaging and the unit are

undamaged.

If damage, missing components or consignment errors are noted, indicate this on the delivery note. A formal complaint should be sent via fax or registered post to the After Sales Service within eight days from the date of receipt of the items.

All the operations involved in handling, installing, starting up and testing the unit must be carried out by qualified personnel. Failure to observe this warning could cause serious damage.

This unit contains R407C refrigerant gas: at the end of its working life, it should be taken to a special collection centre; care should be taken to avoid damage to the gas circuit and the finned coil.

Too low a temperature is harmful to health and a useless waste of energy. Avoid direct contact with the air flow for prolonged periods.

Avoid keeping the room closed for long periods. Open the window regularly to guarantee correct air exchange.

During storms, place the mains switch in the "off" position.

SAFETY RULES

U I A

When operating equipment involving the use of electricity and refrigerant gas, a number of fundamental safety rules must be observed, namely:

The unit must not be used by children or by unfit persons without suitable supervision.

Do not touch the unit with bare feet or with wet or damp parts of the body.

 **Do not carry out cleaning operations** without first disconnecting the unit from the electricity supply by placing the mains switch in the "off" position.

Do not modify safety or regulation devices without authorisation and instructions from the manufacturer.

Do not pull, detach or twist the electrical cables coming out of the unit, even when disconnected from the mains electricity supply.

Do not open doors or panels providing access to the internal parts of the unit.

Do not dispose of, abandon or leave within reach of children packaging materials (cardboard, staples, plastic bags, etc) as they may represent a hazard.

Do not allow refrigerant gas to leak into the atmosphere.

Avoid contact with the refrigerant gas as it is potentially hazardous.

Do not sit or stand on the appliance and/or rest any type of object on top of it.

Do not spray or throw water directly on the appliance.

Do not introduce pointed objects through the air intake and discharge grills.

Respect safety distances between the unit and other equipment or structures. Guarantee suitable space for access to the unit for maintenance and/or service operations.

The internal unit must be installed in a closed technical room. The fan outlets must be protected with ducts or grills preventing access to the impellers.

Power supply: the cross section of the electrical cables must be adequate for the power of the unit and the power supply voltage must correspond with the value indicated on the respective units. All units must be earthed in conformity with legislation in force in the country concerned.

Electrical connections should be carried out as indicated in the instructions to guarantee correct operation of the unit.

Handle the unit with the utmost care (see table on page 3) and avoid damaging it.



IDENTIFICATION

U I A

HED SE direct expansion terminals can be identified by the:

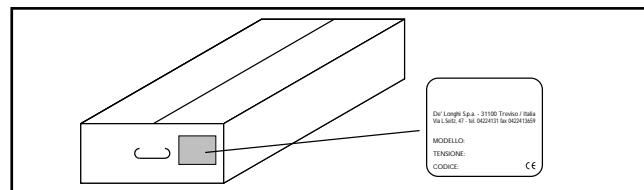

Packaging label

Giving the data identifying the product.

Rating plate

Giving the technical and performance data of the unit. If this is lost, ask the After Sales Service for a replacement.



Tampering with or the removal or absence of rating plates or other means enabling the unit to be identified causes problems during installation and maintenance.

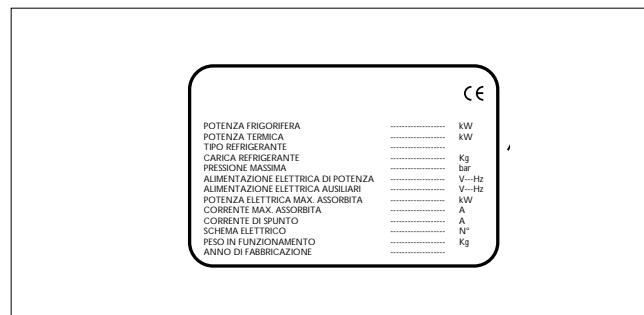

RECEIVING AND HANDLING THE PRODUCT

U I A

HED SE FC direct expansion terminals and **HCAT SE** condenser units are supplied accompanied by:

- instruction manual;
- guarantee certificate;
- CE declaration.

These are contained in a plastic bag attached to the top of the unit.

The unit should always be handled by qualified personnel using equipment adequate for the weight of the unit.



The instruction manual is an integral part of the unit and should thus be read and kept carefully.



Do not dispose of packaging materials in the environment or leave them within reach of children as they may represent a hazard or a source of pollution.



During transport, direct expansion terminals should be handled with extreme care.

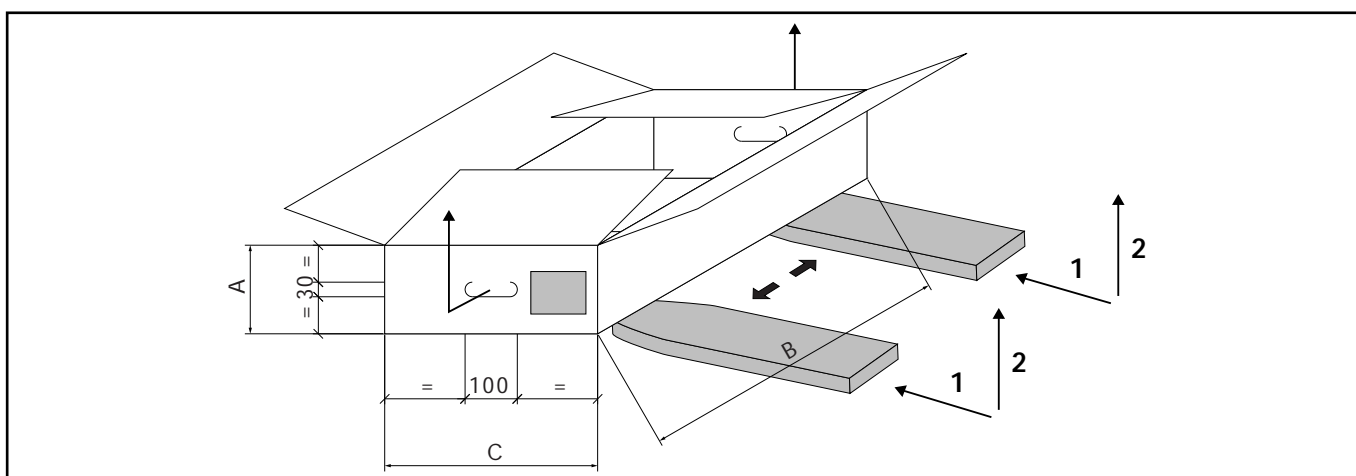

STRUCTURE

Structure in hot-galvanised steel panelling, complete with couplings for connection to ducting and gravity drain condensate pan.

Internal thermal and acoustic insulation in self-extinguishing closed cell expanded polyethylene. Removable regenerable filter in self-extinguishing acrylic, efficiency class EU2.

HEAT EXCHANGE COIL

With copper tubes and high exchange surface area aluminium fins.

FAN

Electric centrifugal fan with electronic speed regulation. Statically and dynamically balanced impellers. High useful head.

ELECTRICAL SWITCHBOARD

Power and control electrical switchboard constructed in accordance with IEC 204-1/EN60204-1, complete with regulation and terminal boards for connection to the electrical power supply and auxiliary controls.

HEATING ELEMENT MODULE

The heating element module consists of a heating element installed on a rack and placed inside the unit. The power is 3kW.

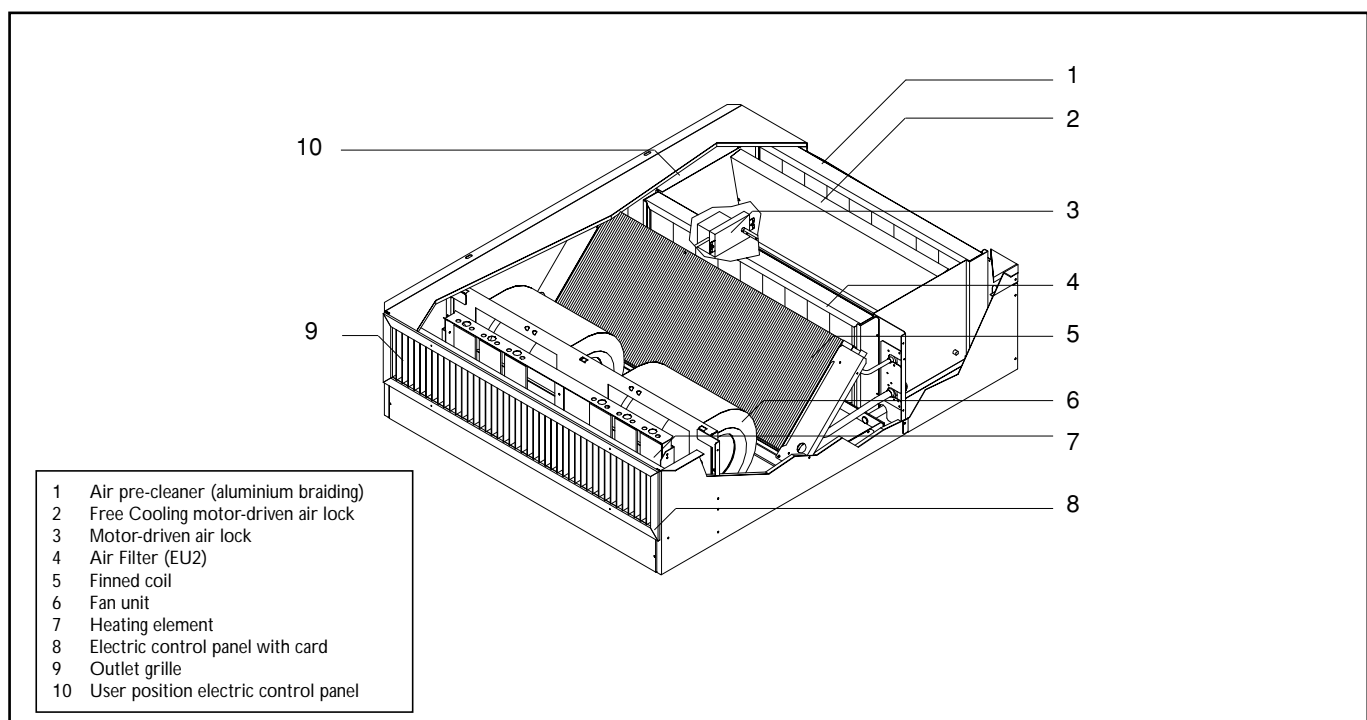



SIZE 0011-0021-0031

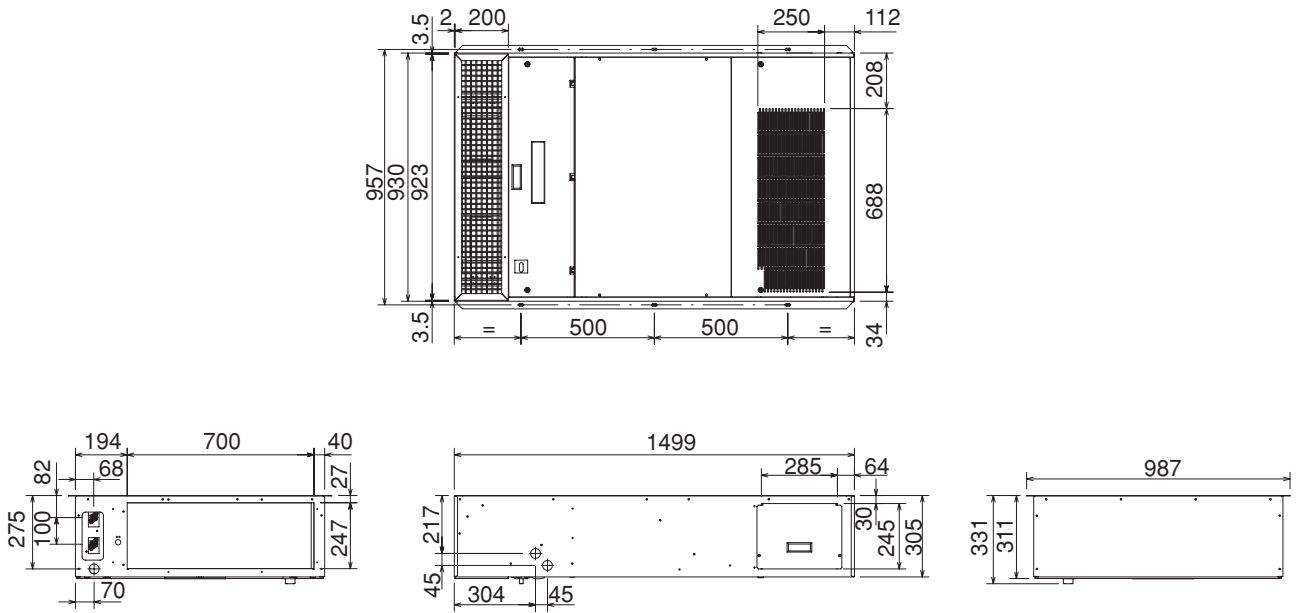

SIZE 0041-0051-0056-0061

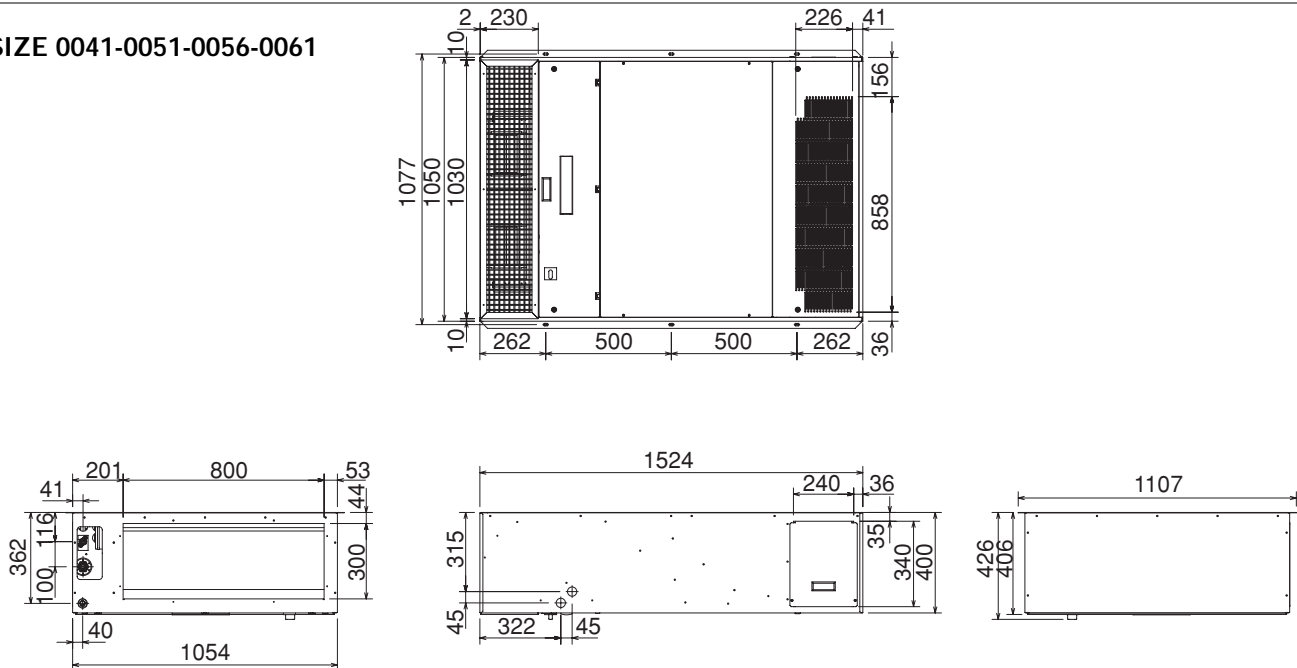

Size HED	Fittings		Weight (kg)
	Ø1	Ø2	
0011-0021-0031	15,8mm-5/8"	9,52mm-3/8"	90
0041-0051-0061	19,05mm-3/4"	12,3mm-1/2"	120

CHOICE OF INSTALLATION SITE

Before installing the unit, agree the site where it will be installed with the customer, taking the following points into consideration:

- check that the fixing points are adequate to support the weight of the unit;
- pay scrupulous respect to safety distances between the unit and other equipment or structures (see Functional Distances);
- install the unit with a minimum slope of 2 mm/m to guarantee condensate drainage.

POSITIONING

Before handling the unit, check the capacity of the lift equipment used, respecting the instructions on the packaging. To move the unit in the horizontal, make appropriate use of a lift truck or similar, bearing in mind the weight distribution of the unit.

Units are supplied with the following accessories to facilitate installation: support brackets, threaded tie rods for ceiling fixing, vibration dampers, washers and fixing bolts. The figure below illustrates the installation procedure. The figure below illustrates the installation procedure.

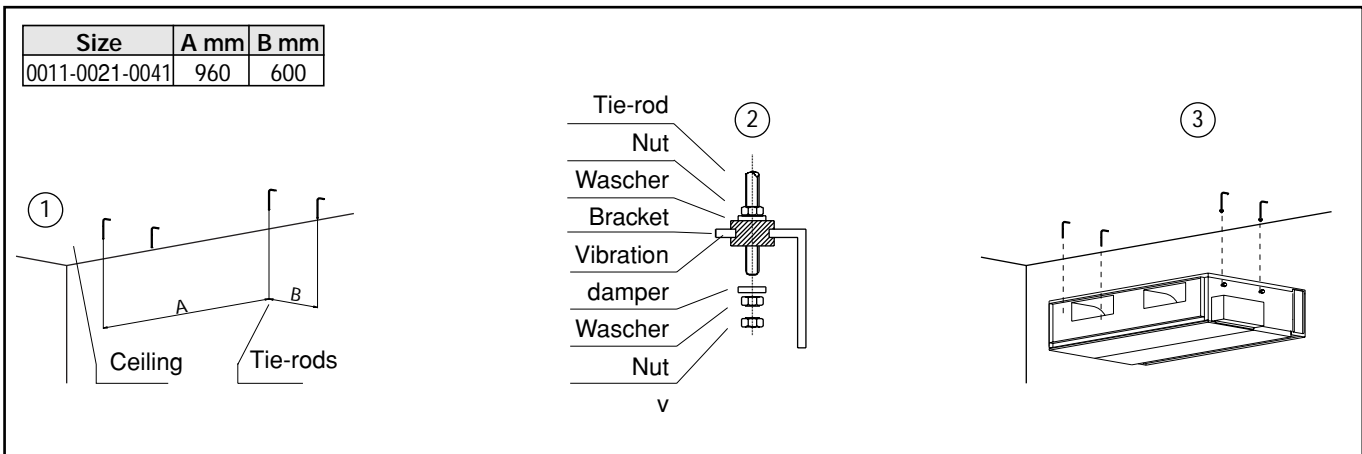

FUNCTIONAL DISTANCES

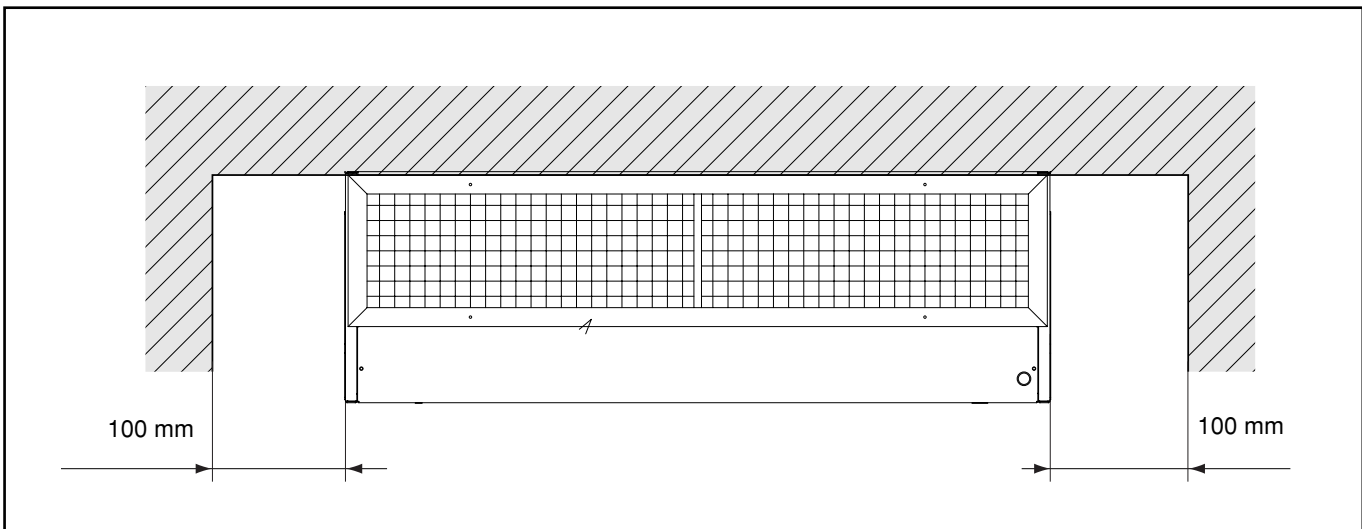

REFRIGERANT PIPES

Sizing of the refrigerant pipes connecting the external condenser units and internal evaporator units is vital to guarantee correct operation. The operation must be carried out with care by specialised personnel only.

INTAKE/DISCHARGE PIPES

Create the coupling flange directly on the pipe; this means less welding and therefore fewer impurities inside the piping. All pipes must be perfectly clean (clean piping with nitrogen or dry air before connecting to the two units) and free from moisture to allow efficient venting.

LIQUID PIPE

To connect, proceed as follows:

1. Connect the pipe to the liquid union coupling using two spanners.
2. Insulate the outside of the pipe and the coupling.

Remember to add R407c refrigerant gas if the piping is more than 5m long.

0011-0021-0041	58 gr/m
----------------	---------

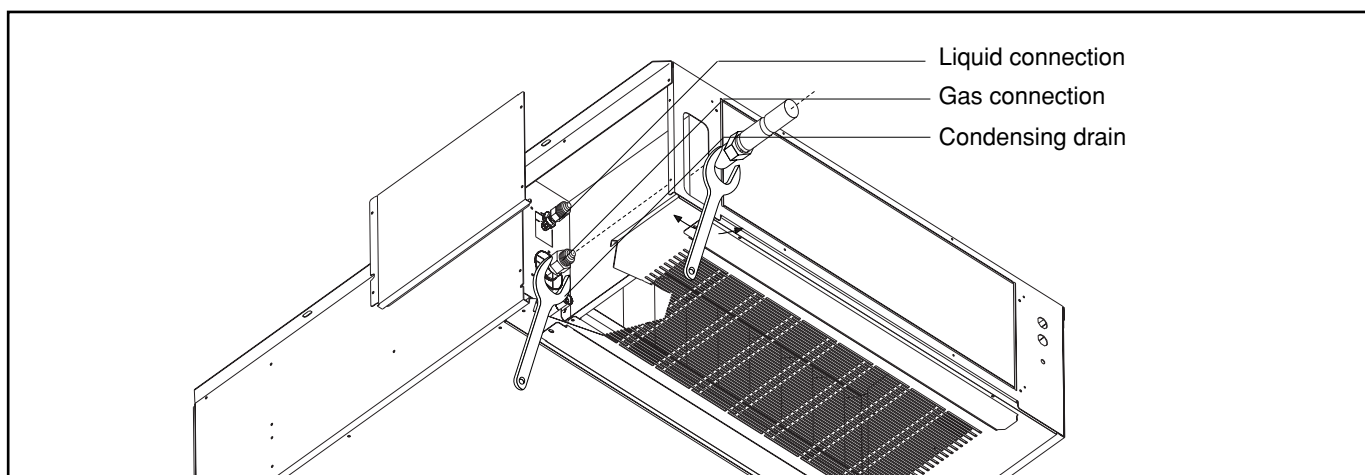

CONDENSATE DRAIN PIPE CONNECTION

This operation must be carried out with particular care.

The unit is fitted with a gravity drainage condensate drain pan with an open connection on the back of the unit. The pipe should have an internal diameter of at least 16 mm. The drain connection has an external diameter of 18 mm. Per the sequence follow to the following instructions: (see figure)

1. Connect the condensate drain hose to the pan outlet with a hose clip.
2. Make sure the drain pipe has a slope of at least 2 cm/m without obstructions or bottlenecks.
3. Fit a siphon. By eliminating the pressure drop caused by

the fan, this prevents air being sucked up by the drain hose.

4. Connect the condensate drain pipe to a rainwater drainage system.

Do not connect to the sewage system as odours may be sucked up if the water in the siphon evaporates.

5. After connecting, check correct drainage of the condensate by pouring water into the pan.

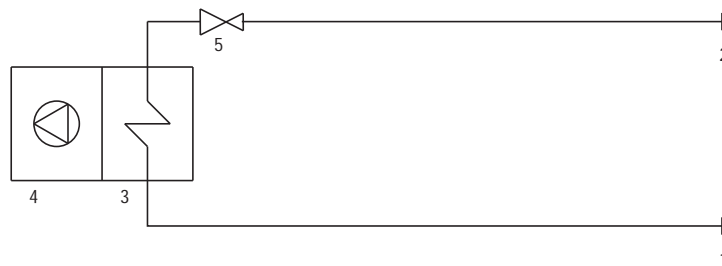

1	Flared gas pipe connection	4	Fan
2	Flared liquid pipe connection	5	Expansion device
3	Finned coil		

POWER CONNECTIONS

The direct expansion terminals leave the factory completely wired and ready for connection to the mains electricity supply, accessories and the receiver. The receiver must be connected using shielded cable to avoid radio interference which could lead to malfunctioning. All electrical connections must be carried out by qualified personnel.

For all electrical work, refer to the electrical wiring diagrams in this manual.

You are also recommended to check that:

- that the characteristics of the mains electricity supply are adequate for the absorptions indicated in the electrical characteristics table below, also bearing in mind the possible use of other equipment at the same time.

⚠ Power to the unit must be turned on only after installation work (mechanical, hydraulic and electrical) has been completed.

All electrical connections must be carried out by qualified personnel in accordance with legislation in force in the country concerned.

Respect instructions for connecting phase, neu-

tral and earth conductors.

The power line should be fitted upstream with a suitable device to protect against short-circuits and leakage to earth, isolating the installation from other equipment. This protection device should also act as a main switch and, if not visible from the electrical panel of the unit, should be lockable.

⚠ Voltage must be within a tolerance of $\pm 10\%$ of the rated power supply voltage for the unit.

If this is not the case, contact the electricity supply company.

For electrical connections, use double insulation cable in conformity with current legislation in the country concerned.

An efficient earth connection is obligatory. Failure to earth the appliance absolves the manufacturer of all liability for damage.

ELECTRICAL POWER CONNECTIONS

To connect the unit to make it operative, insert the power cable of the electric control panel inside the unit and connect to the terminals (U) phase, (N) neutral and (PE) earth,

inserting a suitable residual current circuit breaker with on/off switch between the power outlet and the unit.

ELECTRIC HEAT ELEMENT POSITIONING

I A

	0011-0021-0031	0041-0051-0061
Electric heat element kW	1,5	3

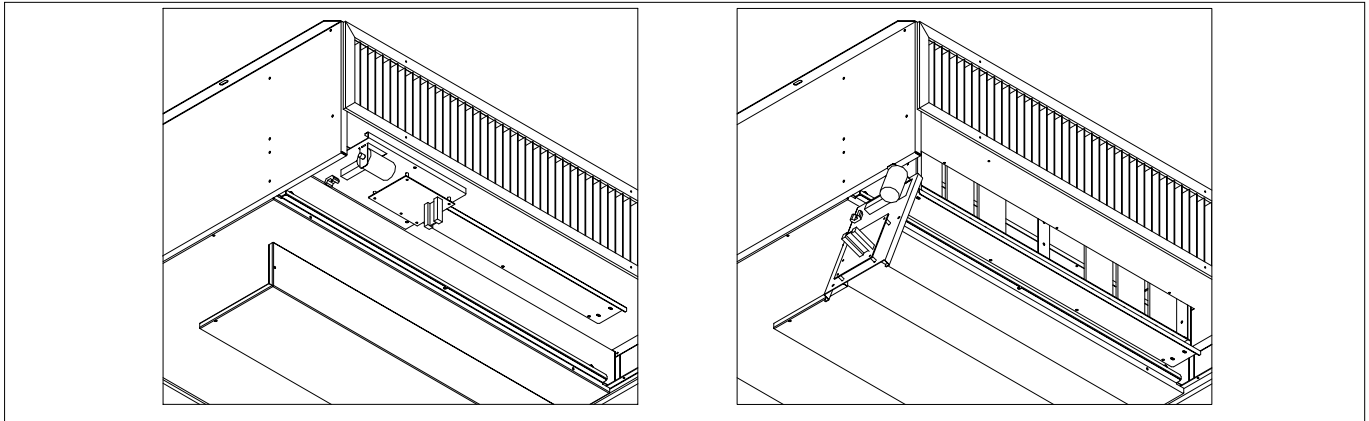

GENERAL TECHNICAL DATA

I A

		0011-0021	0031	0041-0051	10056-0061
Total Cooling capacity	kW	4,7-6,0	7,3	9,0-11	13,8-15,2
Sensible Cooling Capacity	kW	4,4-5,5	6,5	8,7-10,6	13,4-14,0
Unit power supply	V-Ph-Hz	230-1-50	*	400-3-50	400-3-50
Compressor absorbed power	kW	1,20-1,60	1,7	2,8	3,3-4,4
Evaporator air flow rate	l/s	460	500	650	950
Allowed minimum air flow rate in Free-Cooling	l/s	415	450	600	850
Evaporator fan absorbed power	kW	0,20	0,20	0,45	0,9-1,0
Condenser air flow rate	l/s	700	700	1100	1360-1500
Condenser fan absorbed power	kW	0,18	0,18	0,25	0,25-0,70
Heater power	kW	1,50	1,50	3-6	3-6
Max. external operating temperature	°C	48	48	48	48
Min. external operating temperature	°C	-20	-20	-20	-20
External reference temperature	°C	35	35	35	35
Internal reference temperature	50 %UR	+27 °C	+27 °C	+27 °C	+27 °C
Free field external sound pressure at 1 m from the machine	dBA	53	56	56	58
Free field external sound pressure at 1 m from the machine silenced version	dBA - LNV	46	48	51	53

- (*) 230-1-50/400-3-50
 (1) Data measured under the following conditiong : 27°C, 47% U.R. indoor, 35°C outdoor; nominal power
 (2) Measured at outdoor temperature of 35°C, at 1 metre in open field.
 (3) Maximum outdoor temperature referred to internal teperature of 24°C.

IMPORTANT:

- Power to the unit must be disconnected before carrying out maintenance or cleaning.
- At the beginning of the season you are recommended to contact qualified personnel for the seasonal start-up.

To guarantee efficient long term operation of the unit, a number of essential and simple operations and checks should be carried out. **These do not require the intervention of qualified personnel**, but can be carried out by the user:

1. Checking the state of cleanliness of the air filters;
2. Checking the coil;
3. Checking the structural condition of the unit.

CHECKING THE STATE OF AIR FILTERS

Depending on the environment in which the internal unit is installed, the air filters must be cleaned periodically.

In particularly dusty atmospheres, the air filters should be cleaned every three months and you are recommended to have a differential pressure switch installed to indicate when the filters are dirty.

Removing and cleaning filters

1. Remove the fixing screw, then the door.
2. Remove the air filter gently from the bottom, avoiding dispersion of dust in the atmosphere.
3. Wash the filtering layer with warm water and ordinary detergent, rinse and dry thoroughly.
4. Replace the filter
5. Replace the door and fix with the screw.

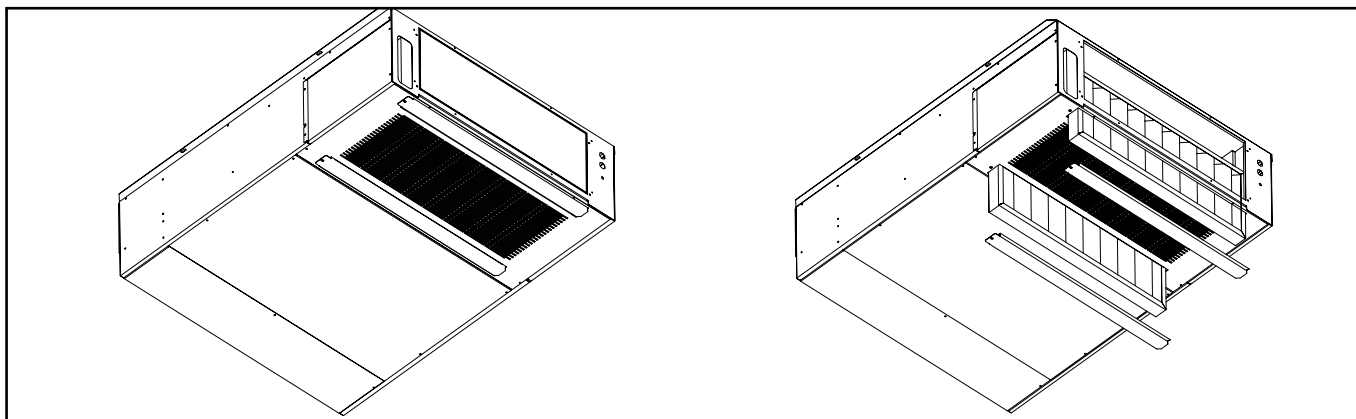

CHECKING THE COIL

1. Remove encrustation and dirt from the coil.
2. Check that the aluminium fins are not bent. If necessary, straighten them using a special tool to restore correct air flow through the coil. This should be done by qualified personnel only.

CHECKING THE STRUCTURAL STATE OF THE UNIT

1. Check the state of preservation of the unit as a whole.
2. Check for the formation of rust. If necessary, treat the parts affected with rust inhibiting paint.

3. Check the fixing of external panels.
4. Check that fixing elements are not causing excessive noise and/or vibrations.
5. Check that the condensate is draining correctly and that the pan is free from encrustation.
6. Check that the power supply cable is in good condition without cracks or lacerations. This should be done by qualified personnel only.

This operation should be carried out by qualified personnel only:

- Check the electric heater module, check electrical absorptions and operation of safety devices

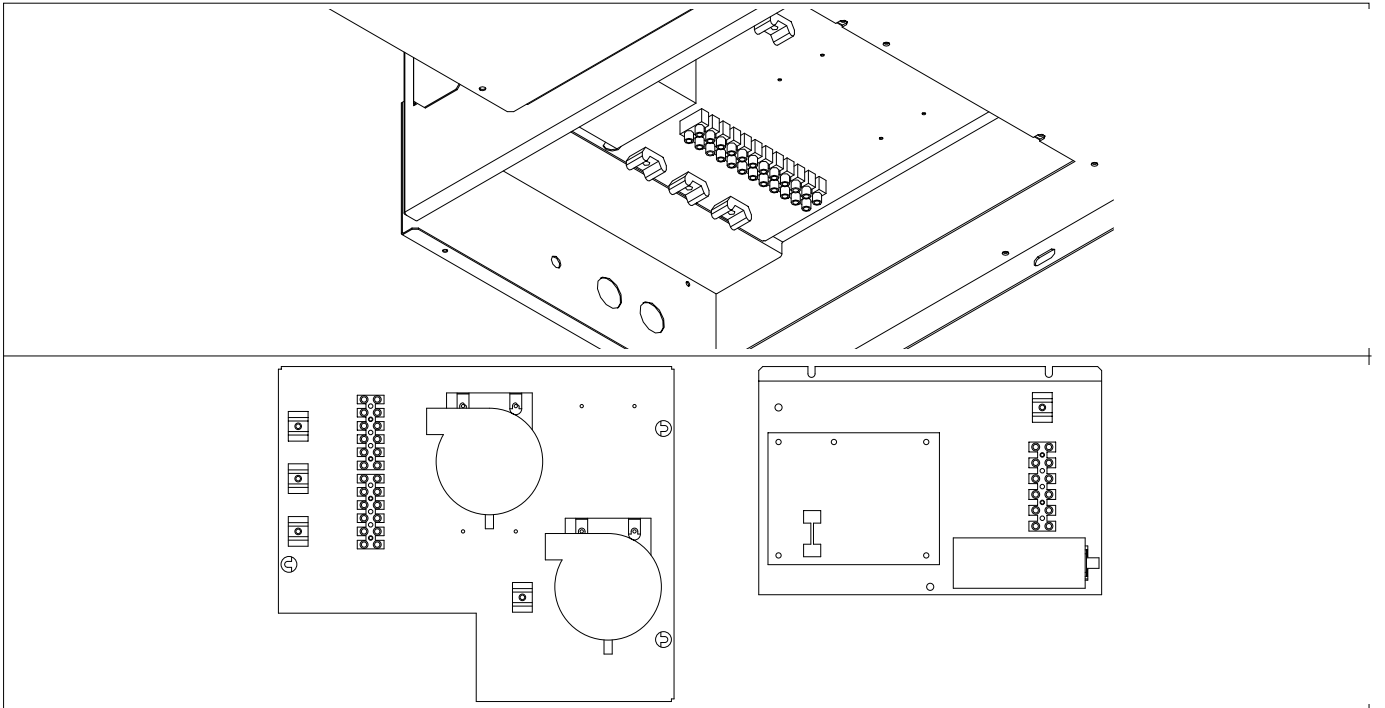

HED HCAT 0011-0021-0031

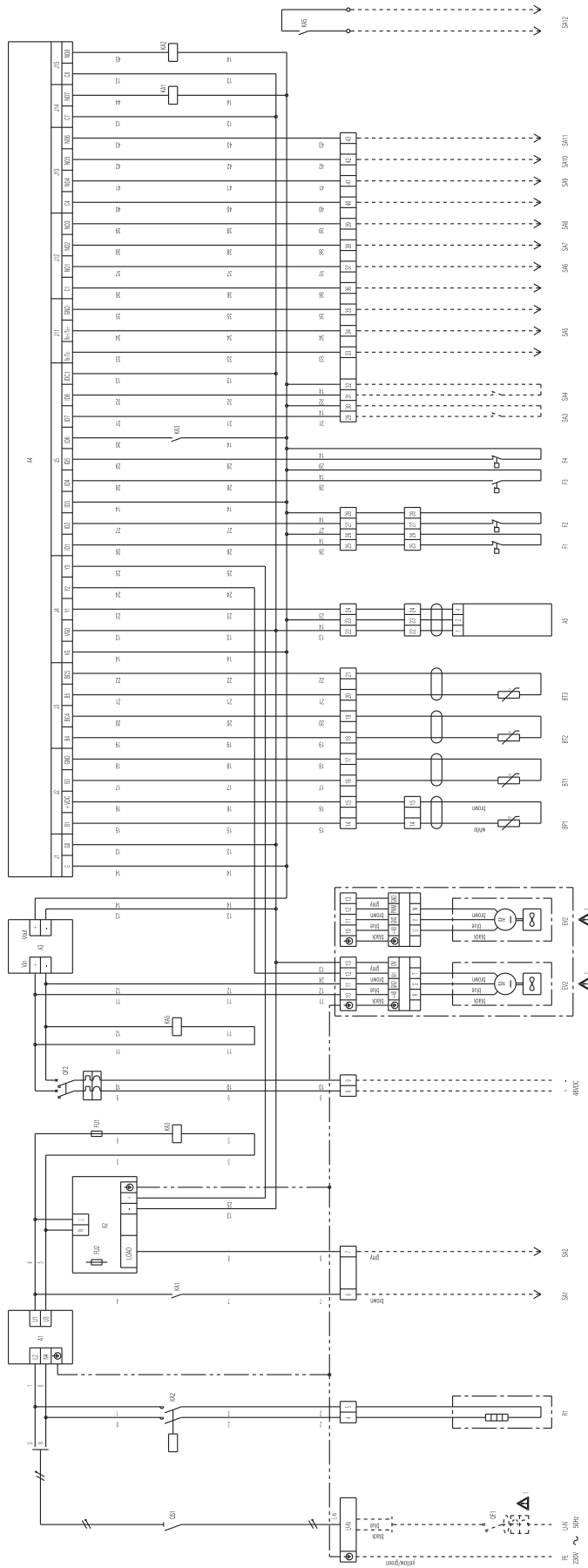

- | | | | | | |
|-----|--|-----|--|------|---|
| A1 | Filtro antidisturbo | F1 | Pressostato di sicurezza bassa pressione | Q1 | Sezionatore bloccoporta |
| A2 | Scheda elettronica comando ventilatore condensazione | F2 | Pressostato di sicurezza alta pressione | R1 | Resistenza elettrica |
| A3 | Convertitore 48VDC/24VDC | F3 | Pressostato mancanza flusso | SA10 | Uscita allarme alta temperatura |
| A4 | Controllore elettronico | F4 | Pressostato filtri sporchi | SA11 | Uscita allarme bassa temperatura |
| A5 | Motore serranda | FU1 | Fusibile di protezione circuito ausiliario | SA3 | Uscita allarme termostato ambiente |
| BP1 | Trasduttore di pressione controllo condensazione | FU2 | Fusibile di protezione ventilatore condensazione | SA4 | Ingresso per allarme termostato ambiente |
| BT1 | Sonda di temperatura aria ambiente | KA2 | Relè di comando resistenza elettrica | SA5 | Ingresso per allarme esterno |
| BT2 | Sonda di temperatura aria esterna | KA3 | Relè presenza tensione 230VAC | SA6 | Collegamento seriale unita' condizionamento |
| BT3 | Sonda di temperatura aria di mandata | KM1 | Contattore potenza comando compressore | SA7 | Uscita allarme flusso |
| C1 | Condensatore marcia compressore | QF1 | Interruttore magnetotermico di protezione gruppo 48VDC | SA8 | Uscita allarme filtri sporchi |
| C2 | Condensatore marcia ventilatore condensazione | QF2 | Interruttore magnetotermico di protezione 48VDC | SA9 | Uscita allarme compressore |
| EV1 | Ventilatore condensazione | QM1 | Interruttore magnetotermico di protezione compressore | Z1 | Compressore |
| EV2 | Ventilatore aria interna | | | | |

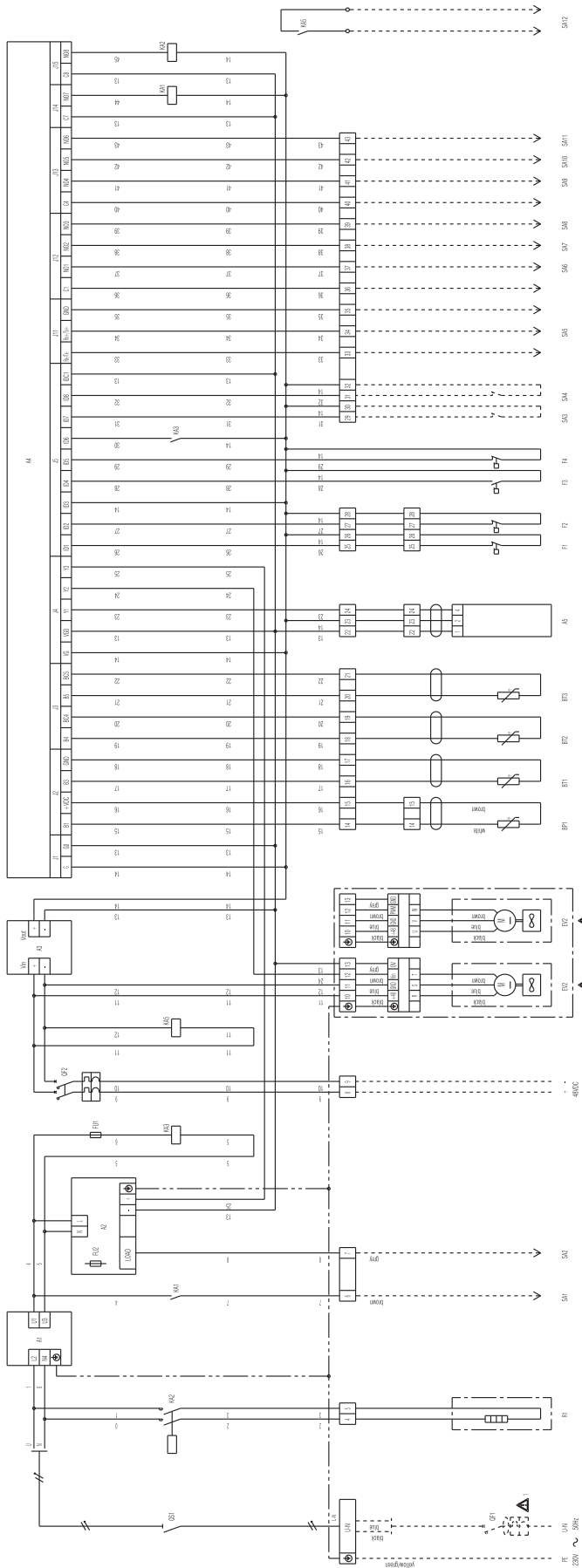

- | | | | | | |
|-----|--|-----|---|------|---|
| A1 | Filtro antidisturbo | F1 | Pressostato di sicurezza bassa pressione | Q51 | Sezionatore bloccoporta |
| A2 | Scheda elettronica comando ventilatore condensazione | F2 | Pressostato di sicurezza alta pressione | R1 | Resistenza elettrica |
| A3 | Convertitore 48VDC/24VDC | F3 | Pressostato mancanza flusso | SA10 | Uscita allarme alta temperatura |
| A4 | Controllore elettronico | F4 | Pressostato filtri sporchi | SA11 | Uscita allarme bassa temperatura |
| A5 | Motore serranda | FU1 | Fusibile di protezione circuito ausiliario | SA3 | Ingresso per allarme termostato ambiente |
| BP1 | Trasduttore di pressione controllo condensazione | FU2 | Fusibile di protezione ventilatore condensazione | SA4 | Ingresso per allarme esterno |
| BT1 | Sonda di temperatura aria ambiente | KA2 | Rele' di comando resistenza elettrica | SA5 | Collegamento seriale unita' condizionamento |
| BT2 | Sonda di temperatura aria esterna | KA3 | Rele' presenza tensione 230VAC | SA6 | Uscita allarme flusso |
| BT3 | Sonda di temperatura aria di mandata | KM1 | Contattore potenza comando compressore | SA7 | Uscita allarme filtri sporchi |
| C2 | Condensatore marcia ventilatore condensazione | QF1 | Interruttore magnetotermico di protezione gruppo | SA8 | Uscita allarme compressore |
| EV1 | Ventilatore condensazione | QF2 | Interruttore magnetotermico di protezione 48VDC | SA9 | Uscita allarme freecooling |
| EV2 | Ventilatore aria interna | QM1 | Interruttore magnetotermico di protezione compressore | Z1 | Compressore |
| EV3 | Ventilatore aria interna | | | | |

IDENTIFICATION

I A

The **HCAT SE** condenser units can be identified by the:

Packaging label

Giving the data identifying the product.

Rating plate

Giving the technical and performance data of the unit.

If lost, ask the After Sales Service for a duplicate.

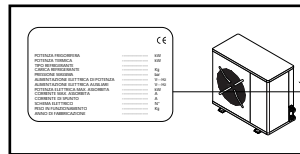
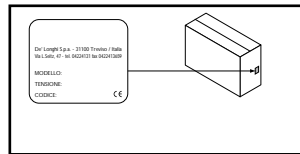

⚠ Tampering with or the removal or absence of rating plates or other means enabling the unit to be identified causes problems during installation and maintenance.

RECEIVING AND HANDLING THE PRODUCT

I A

The **HCAT SE** condenser units are supplied accompanied by:

- instruction manual;
- guarantee certificate;
- CE declaration.

These are contained in a plastic bag (A) attached to the top of the unit.

The unit should always be handled by qualified personnel using equipment adequate for the weight of the condenser unit. If a forklift truck is used, insert the forks under the bed plate, spacing the forks as wide apart as possible.

If a crane is used, pass the cables through the bottom of the bed plate, making sure they do not exert pressure on the unit. Once the packaging has been removed, the unit can be lifted and moved by inserting two metal tubes (max. diameter: 1/2") into the feet provided for this purpose and using suitable handling equipment.



The instruction manual is an integral part of the unit and should thus be read and kept carefully.



Do not dispose of packaging materials in the environment or leave them within reach of children as they may represent a hazard.



The weight of the condenser unit is biased towards the compressor side (side of the packaging with the bar code, see figure at the foot of the page). **During transport**, the condenser unit must be kept in the vertical position.

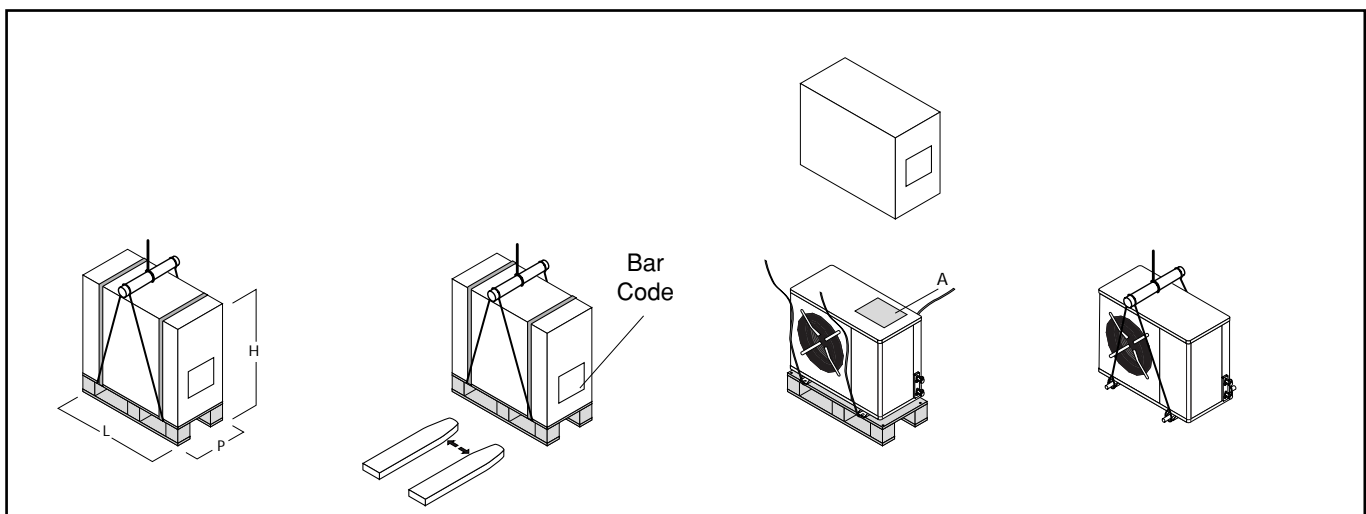

Size	0011-0021-0031	0041-0051-0061
Dimension L	1060	1060
Dimension P	460	460
Dimension H	880	980
Gross Weight	80	87

The air-cooled condenser units with axial-flow fans operate with R407C refrigerant and are suitable for outdoor installation, for use with HED direct expansion terminals.

The units conform to the essential requisites established in **EC directive 89/392**.

They are factory tested and on site installation is limited to refrigerant and electrical connections.

Condensate pan (mod. 0011÷0061) and heat exchanger protection grill fitted as standard.

STRUCTURE

Panels and bed plate are made from **cataphoretic coated galvanised steel** to ensure total resistance to atmospheric agents.

COMPRESSORS

Hermetic **rotary scroll compressor** with sump heater and thermal cut-out.

CONDENSER

Made using copper tubes and aluminium fins with a high exchange surface area. Connections with cocks and flared fittings.

FANS

Statically and dynamically balanced low revolution external impeller axial-flow fans.

Six-pole electric motor with built-in thermal cut-out.

Housed in aerodynamic draught tubes with accident prevention grill. **Device for operation according to outsi-**

de air temperatures: continuous regulation of fan rotation speed via **temperature transducer**.

REFRIGERANT CIRCUIT

The unit features a refrigerant circuit with the following components: filter, liquid receiver, safety pressure switches to control discharge and intake pressure. Unit supplied complete with non-freezing oil and R407C refrigerant, **factory tested**.

POWER AND CONTROL ELECTRICAL PANEL

Power and control electrical panel constructed in accordance with IEC 204-1/EN60204-1, complete with compressor contactor, thermal overload switch and **door lock safety device**. **Control via "HSA 2" control panel**.

OPTIONAL ACCESSORIES

- Rubber vibration dampers.
- Wall mounting brackets.
- Condensate pan (mod.0071).

The above accessories are optional. Consult the relative documentation for assembly instructions and technical data.

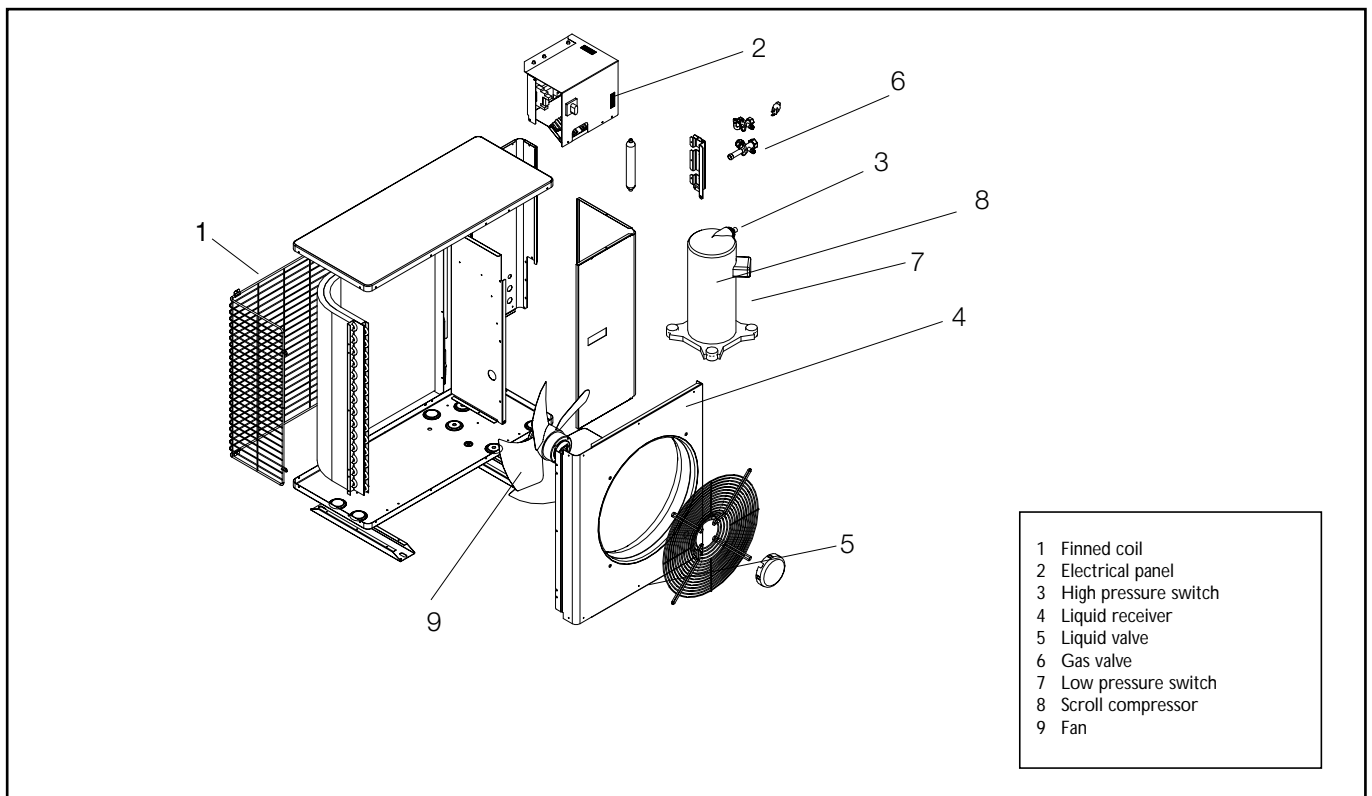

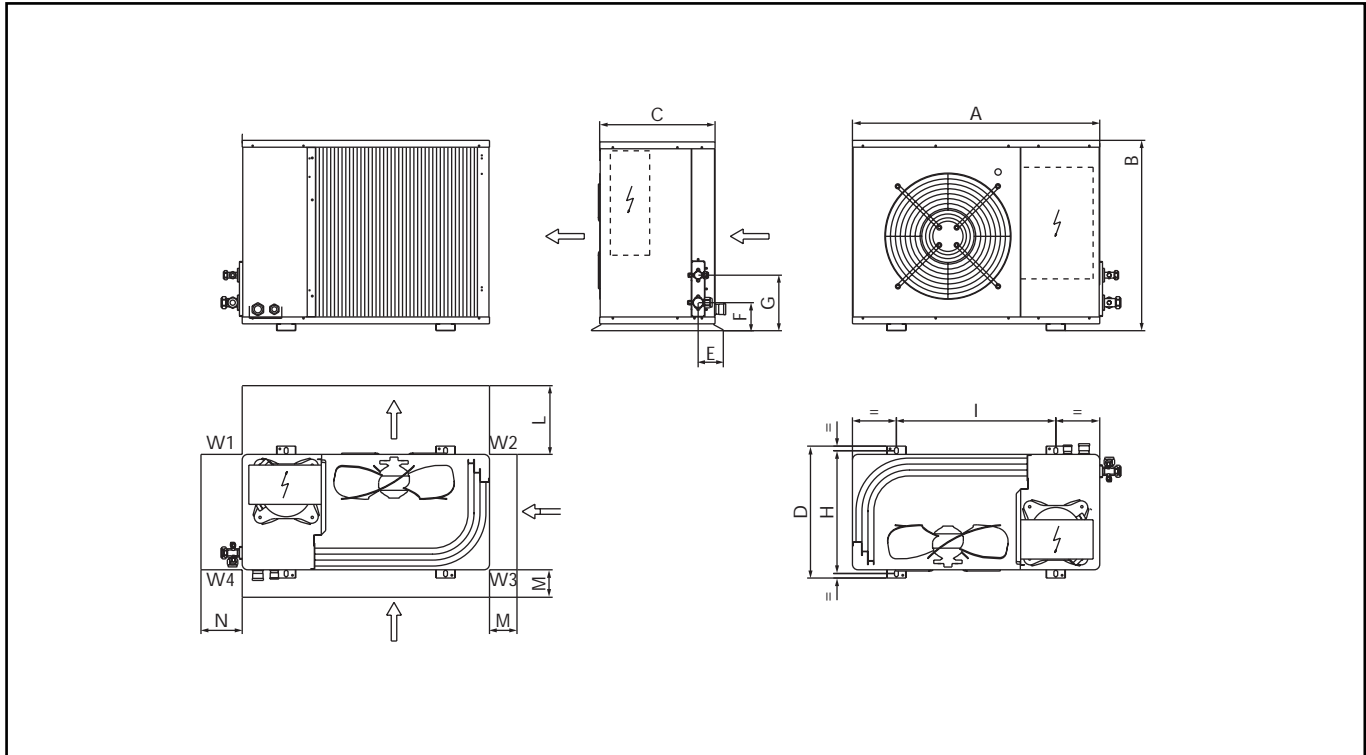

Dimension	0011-0021-0031	0041-0051-0056	0061
A	900	900	900
B	740	990	1250
C	370	370	420
D	430	430	480
E	91,5	91,5	91,5
F	102	102	102
G	202	202	202
H	400	400	450
I	580	580	580
O	-	-	-
Functional distance			
L	900	900	900
M	150	150	200
N	600	600	600
Weights distribution			
W1	33	43	46
W2	14	18	21
W3	11	14	18
W4	26	34	38
TOT	84	109	123

CHOICE OF INSTALLATION SITE

Before installing the unit, agree the site where it will be installed with the customer, taking the following points into consideration:

- check that the fixing points are adequate to support the weight of the unit;
- pay scrupulous respect to safety distances between the unit and other equipment or structures to ensure that air entering the unit and discharged by the fans is free to circulate;
- the unit must be installed in a space designed to house technical installations dimensioned according to legislation in force in the country concerned and large enough to allow access for maintenance.

POSITIONING

Before handling the unit, check the capacity of the lift equipment used, respecting the instructions on the packaging.

To move the unit horizontally, make appropriate use of a lift truck or similar, bearing in mind the weight distribution of the unit. To lift the unit, insert tubes long enough to allow positioning of the lifting slings and safety pins in the special holes in the bed plate of the unit.

To avoid the slings damaging the unit, place protection between the slings and the unit. Position the unit in the site indicated by the customer. Place a layer of rubber (min. thickness 10 mm) between the bed plate and support surface. Fix the unit, making sure it is level and that there is easy access to

refrigerant and electrical components. If the site is exposed to strong winds, fix the unit adequately using tie rods if necessary.

You are advised to avoid:

- Installing the unit in pits and/or air vents;
- obstacles or barriers which could cause the air discharged to be recycled;
- installation in sites with an aggressive atmosphere;
- installation in confined spaces where the sound levels of the appliance could be amplified by reverberation or resonance;
- installation in corners where dust, leaves or other materials tend to collect. These could obstruct the passage of air, thus reducing the efficiency of the unit;
- air discharged by the unit entering inhabited rooms through doors or windows causing unpleasant conditions for the inhabitants;
- air discharged by the unit being obstructed by a wind blowing in the opposite direction;
- direct exposure of the unit to sunlight.

REFRIGERANT CONNECTIONS

REFRIGERANT PIPES

Sizing of the refrigerant pipes connecting the external condenser units and internal evaporator units is vital to guarantee correct operation.

The table on pages 8 and 9 gives the diameters of pipes for connecting the **HED-HCAT SE** units, the maximum admissible

length and the maximum difference in level, both with the condenser unit located at a lower level than the terminal unit and vice versa.

For greater distances, the diameter must be calculated. Use only copper piping for refrigerant use.

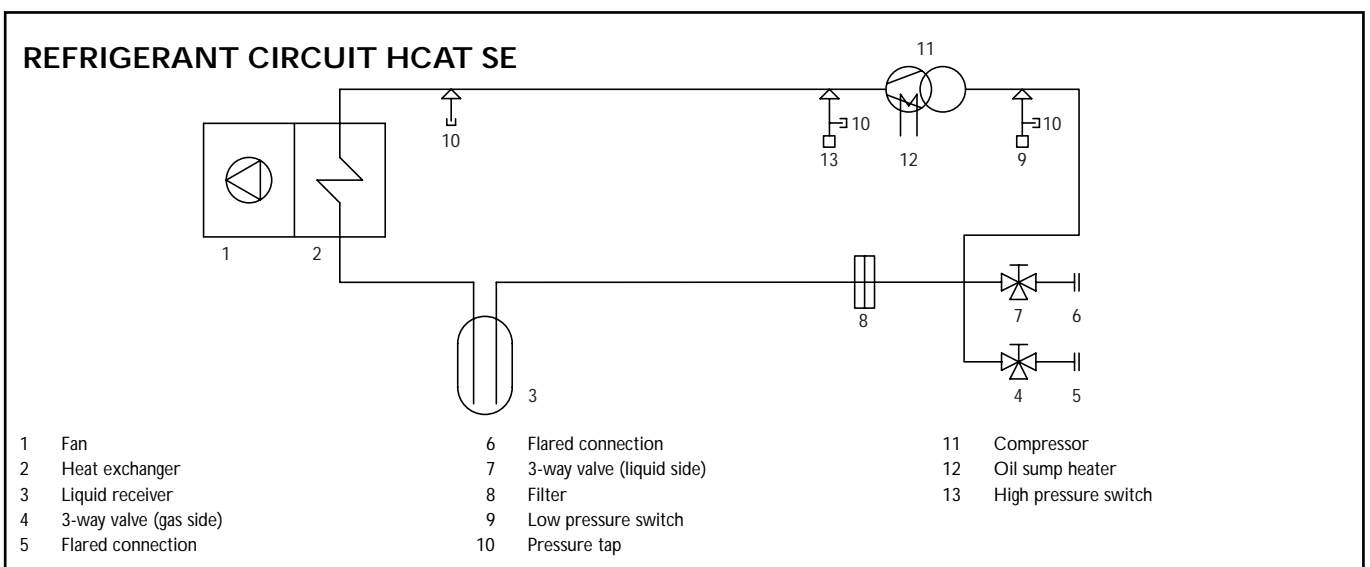

The **HCAT SE** units are pre-filled with a sufficient quantity of refrigerant for connection to the corresponding HED internal unit and for a maximum pipe length of 5m.

PROCEDURE FOR CORRECT CONNECTION

Intake/discharge piping

1. Insulate the piping adequately with anti-condensate “closed cell” type polyethylene to a minimum thickness of 9 mm.
2. If the external unit is lower than the internal unit, a siphon must be fitted to avoid fluid returning towards the compressor (see Fig. 1).
3. If the external unit is higher than the internal unit by less than 6m, it is sufficient to fit an air trap before the internal unit (see Fig. 2).
4. If the external unit is higher than the internal unit by more than 6m, an oil collection siphon should be fitted

every 6m and an air trap should be included before the internal unit (see Fig. 3).

5. When installing the piping, make sure all bends have a large radius. Avoid hairpins. Do not squash the pipes.

Liquid piping

1. Avoid using excessive diameters to avoid excessive refrigerant content;
2. If the piping is exposed to heat sources, insulate it appropriately.

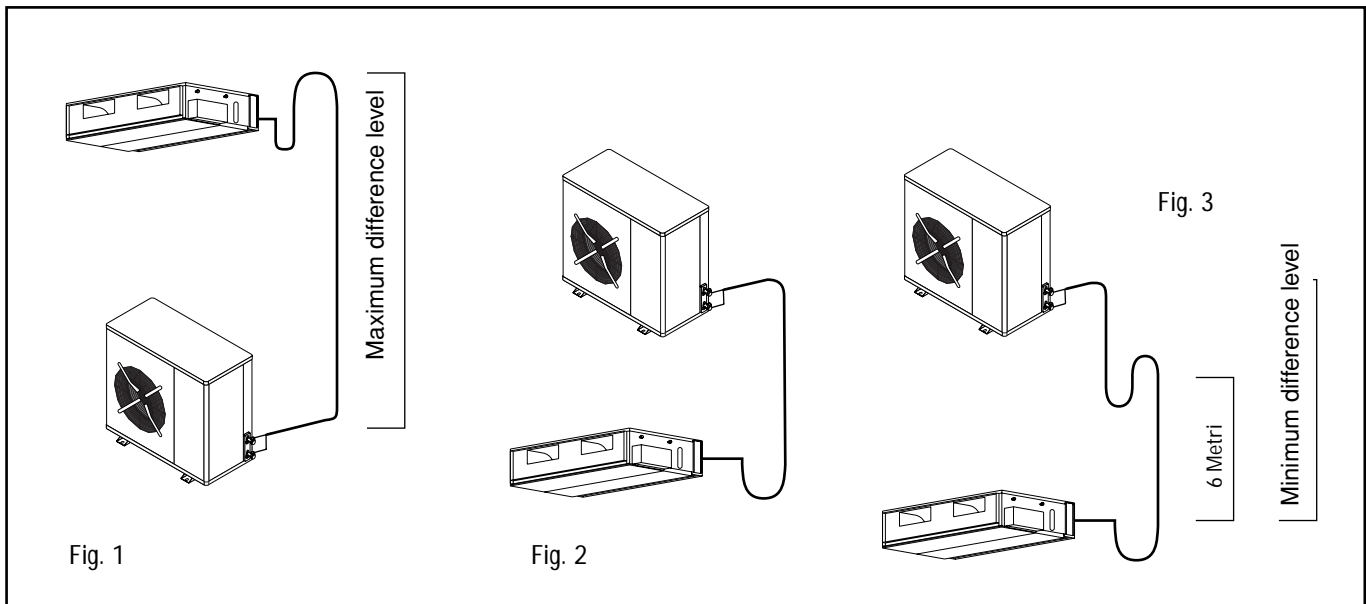

SIZING CONNECTION PIPING IN RELATION TO EQUIVALENT DISTANCE

Model		0011	0021	0031	0041-0051	0061
Type of pipe	0-10 m eq.					
Intake/discharge	Ø mm		16		16	18
Liquid	Ø mm		10		10	12
Type of pipe	10-20 m eq.					
Intake/discharge	Ø mm		16		18	22
Liquid	Ø mm		10		10	12
Type of pipe	20-30 m eq.					
Intake/discharge	Ø mm		18		18	28
Liquid	Ø mm		10		10	16
Pipe diameter		10	12	16	22	28
Size of pipe						
Intake	gr./m	-	2,6	4,3	8,9	15,2
Discharge	gr./m	-	20	34	73	120
Liquid	gr./m	66	100	178	364	-

N.B.: Attenzione l'aggiunta di gas comporta un'aggiunta di olio lubrificante nella misura del 10% del peso del gas refrigerante.

EQUIVALENT CORRESPONDING LENGTH, 90° CURVE AND COMPLETE SIPHON

Pipe diameter	Øi / Øe	8/10	10/12	14/16	16/18	20/22	26/28	33/35	39/42
90° curve	m eq.	0,40	0,42	0,48	0,50	0,60	0,80	1,00	1,20
Siphon	m eq.	1,60	1,68	1,92	2,00	2,40	3,20	4,00	4,80

INTAKE PIPING

Flared couplings are used for all models. To connect, proceed as follows:

1. Prepare the end of the pipe, creating the correctly shaped flare.
2. Connect the prepared pipe to the intake pipe shut-off valve using two spanners as shown in the figure below.

LIQUID PIPING

Flared couplings are used for all models. To connect, proceed as follows:

1. Prepare the end of the pipe, creating the correctly shaped flare.
2. Connect the prepared pipe to the liquid pipe shut-off valve using two spanners as shown in the figure below.

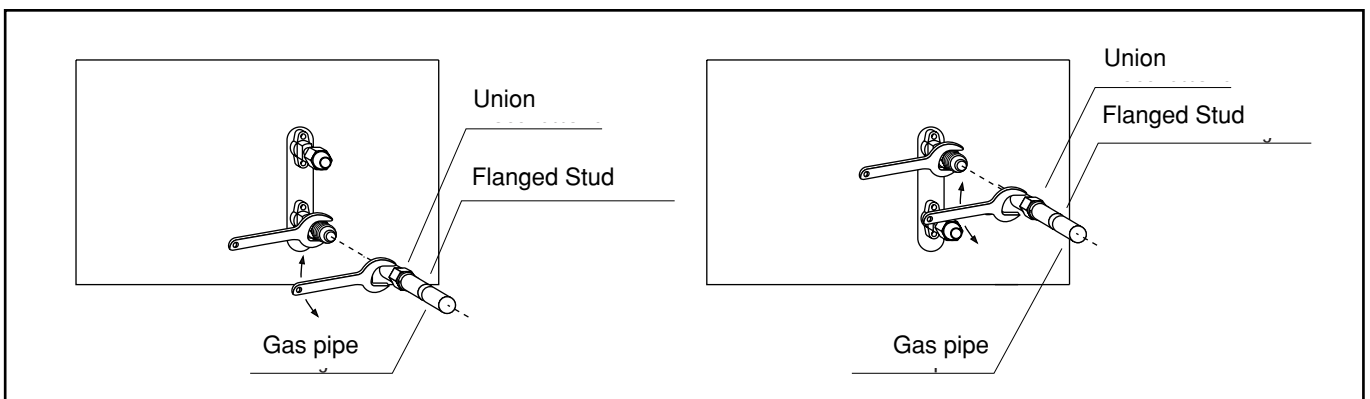

Note: The use of a flare connected directly to the piping limits impurities inside the pipe. All pipes must be perfectly clean (clean piping with nitrogen or dry air before connecting to the two units) and free from moisture to allow efficient venting.

ting to the two units) and free from moisture to allow efficient venting.

SIZE AND POSITION OF CONNECTIONS

Size	0011-0021-0031	0041-0061
A (mm)	91,5	91,5
B (mm)	102	102
C (mm)	202	202
Gas connection (mm/inch)	15,9mm-5/8"	19,05mm-3/4"
Liquid connection (mm/inch)	9,52mm-3/8"	12,8mm-1/2"

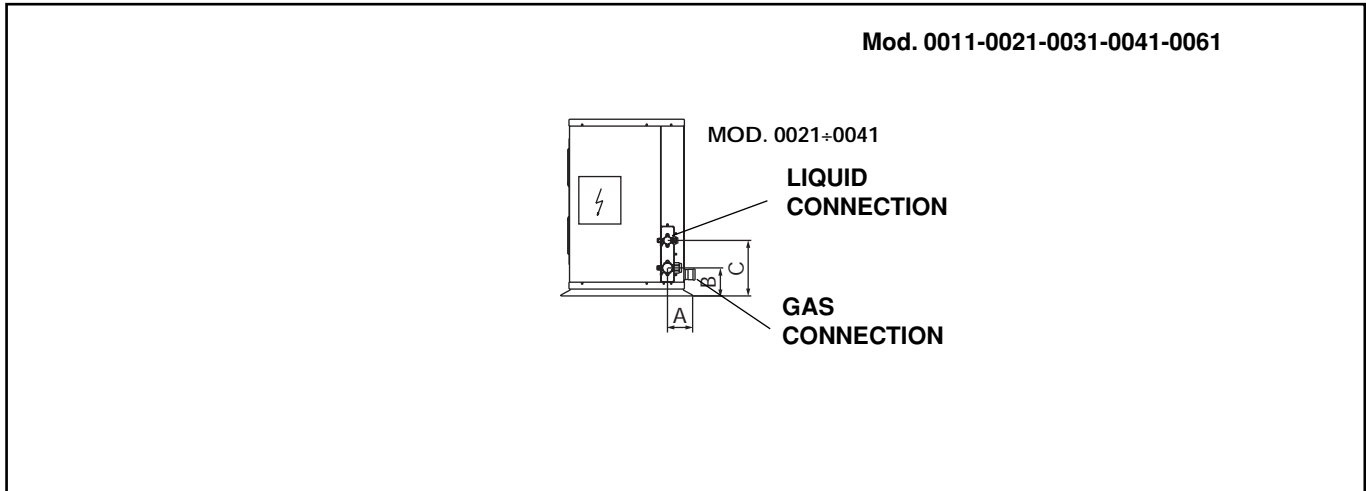

CHECKING FOR LEAKS

1. Check that the valves on the external unit are completely closed;
2. Connect the pressure gauge to the service outlet of the two external unit valves;
3. Fill with freon R407C gas at a pressure of 250 kPa;
4. Connect the nitrogen cylinder to the valves and bring the circuit up to a pressure of 1,200 kPa;
5. Using a leak detector light or other electronic instrument, make sure there are no leaks. When complete, remove the pressure within the pipework.

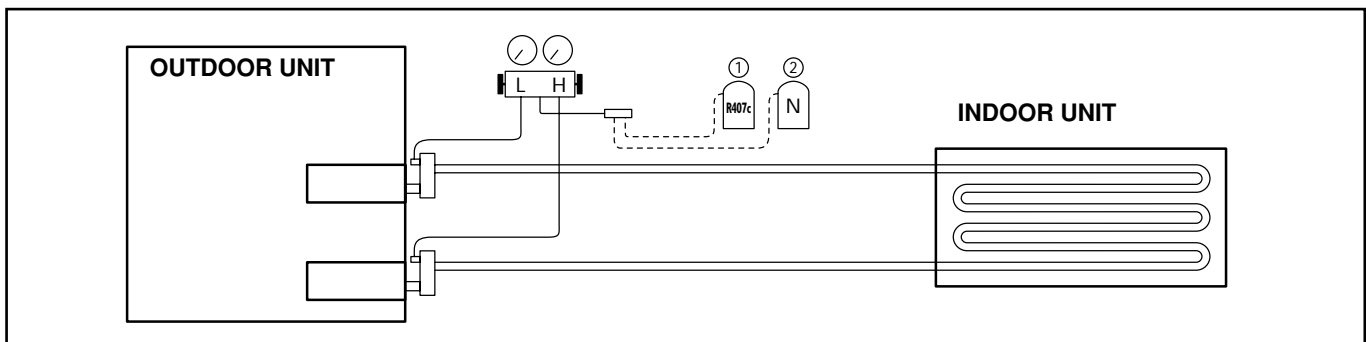

The **HCAT SE** condenser units leave the factory fully wired. Installation is limited to connection to the mains electrical supply and connection of the remote (ON/OFF) switch, operations that must be carried out by qualified personnel in compliance with current legislation. For all electrical work, refer to the electrical wiring diagrams in this manual.

You are also recommended to check that:

- The characteristics of the mains electricity supply are adequate for the absorptions indicated in the electrical characteristics tables below, also bearing in mind the possible use of other equipment at the same time.

⚠ Power to the unit must be turned on only after installation work (refrigerant and electrical) has been completed.

All electrical connections must be carried out by qualified personnel in accordance with legislation in force in the country concerned.

Respect instructions for connecting phase, neutral and earth conductors. The power line should be fitted upstream with a suitable device to protect against short-circuits and leakage to earth, isolating the installation from other equipment.

⚠ Voltage must be within a tolerance of $\pm 10\%$ of the rated power supply voltage for the unit (for three phase units, the unbalance between the phases must not exceed 3%). If this is not the case, contact the electricity supply company.

For electrical connections, use double insulation cable in conformity with legislation in force in the country concerned.

Install, if possible near the unit, an appropriate protection device to isolate the unit from the mains supply. This should have a delayed characteristic curve, contacts opening by at least 3 mm and an adequate interruption and differential protection capacity.

If this device is not visible from the electrical panel of the unit, it should be lockable.

An efficient earth connection is obligatory. Failure to earth the appliance absolves the manufacturer of all liability for damage.

In the case of three phase units, ensure the phases are connected correctly.

⊘ Do not use refrigerant pipes to earth the unit.

ELECTRICAL PANEL

The electrical panel is located inside the unit at the top of the technical compartment where the various components of the refrigerant circuit are also to be found. To access the electrical panel, remove the front panel of the unit by undoing the self-tapping screws. To access the components in the electrical panel and the terminal boards, undo the four screws on the panel itself.

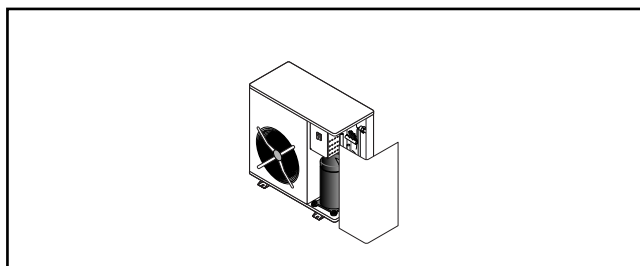

Cooling (°C)	Inside temp. BS/BU °C.	Outside temp. BS/BU °C.
Max	32 / 23,5	50 / -
Min	20 / 14,0	-20 / -

BS: Bulbo secco
 BU: Bulbo umido

SAFETY SETTINGS

	Opens (bar)	Closes (bar)	RESET
High pressure switch	28,0	23,0	manual
Low pressure switch	0,7	1,7	automatic

PREPARING FOR FIRST START UP

Before starting up the condenser units, make sure that:

- All safety conditions have been respected.
- The condenser unit is adequately fixed to the surface it rests on.
- Functional distances have been respected;
- The refrigerant connections have been carried out as indicated in the instruction manual.
- The circuit has been vented;
- The refrigerant circuit valves are open;
- Electrical connections have been carried out correctly;
- The voltage is within a tolerance of 10% of the rated voltage for the unit.
- The unit is correctly earthed;
- All electrical connections are tight and all refrigerant connections have been carried out correctly.

 Before starting up, power up the unit for at least two hours by positioning QF and QS to ON, to allow the oil in the compressor sump to heat up.

STARTING UP FOR THE FIRST TIME (after two hours)

Before activating the condenser unit:

- Make sure that the main remote switch QF is in the OFF position

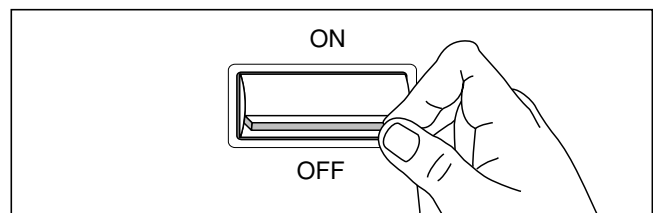

- Remove the inspection pane

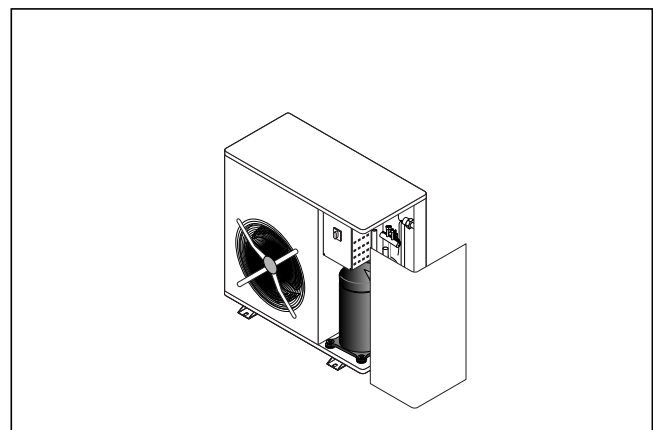

- Remove the door of the electrical panel, setting QS to OFF

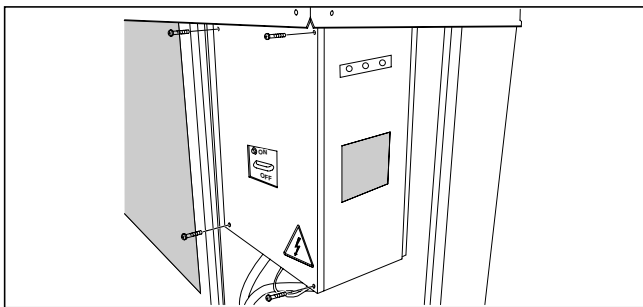

- Place the compressor thermal overload switch QM1 in the ON position

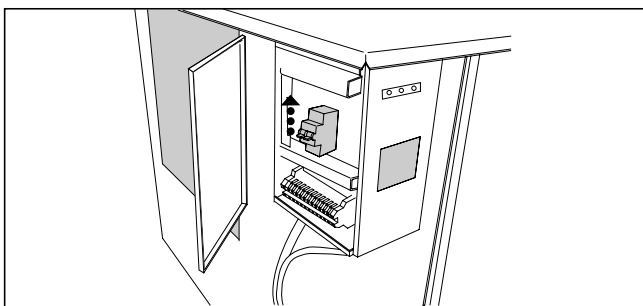

- Close the electrical panel door and fasten the screws
- Place the switch main QS of the appliance in the ON position

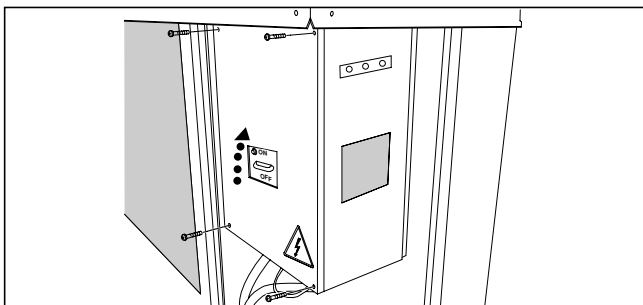

- Replace the inspection panel

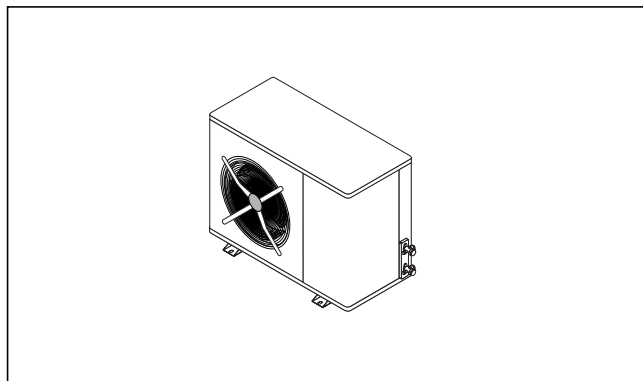

- Place the main switch of the unit QF (outside of the unit) in the "ON" position

ACTIVATING AND DEACTIVATING THE UNIT

- Place the remote switch SA1 (if present) in the ON position.

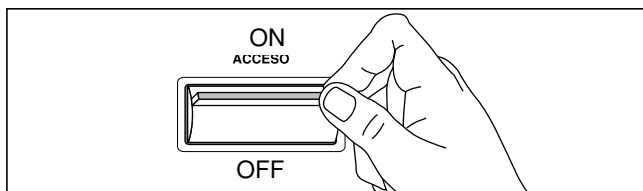

- The ACTIVATION and DEACTIVATION operations are controlled by the combined HED internal unit

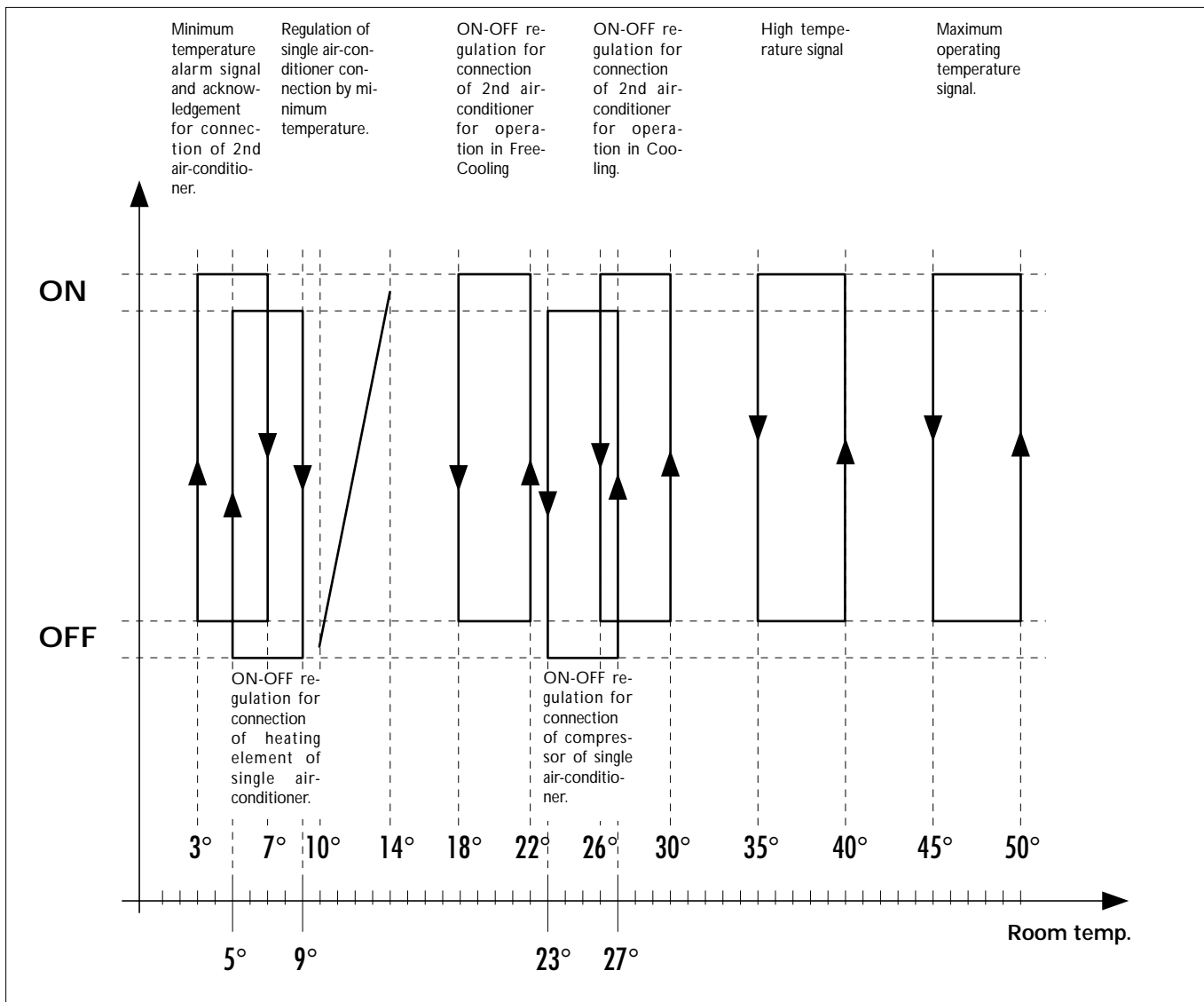

Microprocessor card programming for the control of the single air-conditioner in the system:

- 1 Function of rotation of sequence of connection of the air-conditioners on the basis of the switching off of the last compressor, with priority of switching on for the other compressor, unless already operating, with daily reset of the frequency.
- 2 With $T_e < T_a$ ($\Delta T > 3^\circ\text{C}$): Free-Cooling mode
- 3 With $T_a \geq 12^\circ\text{C}$ e $T_i > T_a$ ($\Delta T \geq 2^\circ\text{C}$): alarm signal due to Free-Cooling air lock or electric heater anomaly.

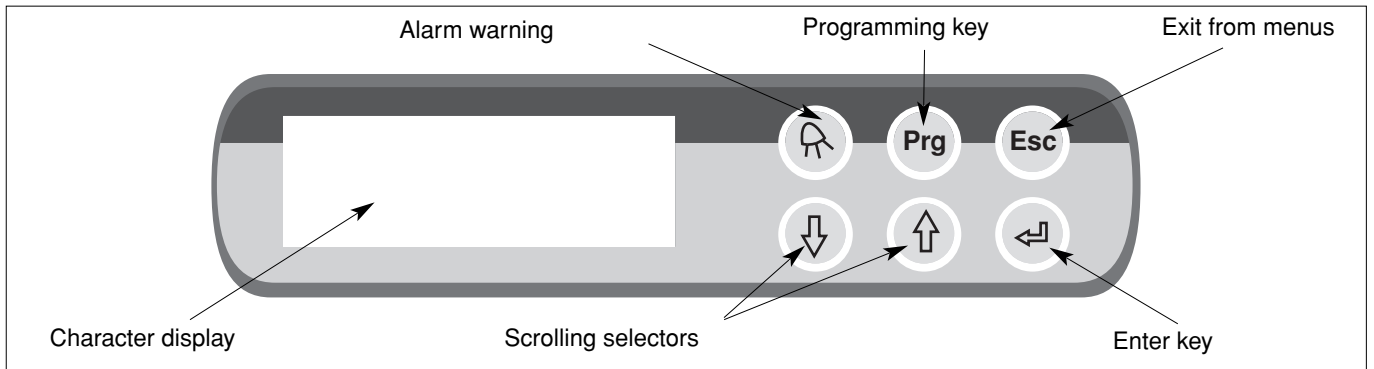

Unit controller Standard display

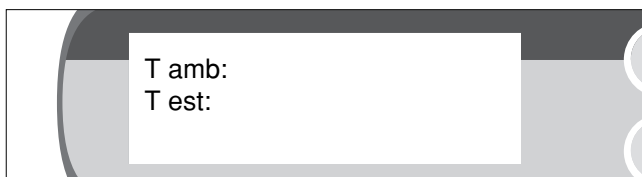

The standard display page shows the main measurement values of the units:

- Internal temperature
- External temperature
- Mode of operation
- Compressor status
- Opening of the damper

Alarm display



The alarm status is shown on the display and the alarm button turns red. Press the button to display a description of the cause of the alarm and the date and time it occurred.

The controller stores the last 100 alarms.

The indicated alarms are:

- Maximum temperature
- Maximum temperature pre-alarm
- Minimum temperature
- Internal fan
- Dirty filters
- Heating elements
- High pressure
- Low pressure
- Fan/compressor thermal cutout
- Freecooling alarm
- Blackout alarm

Display and editing of unit parameters

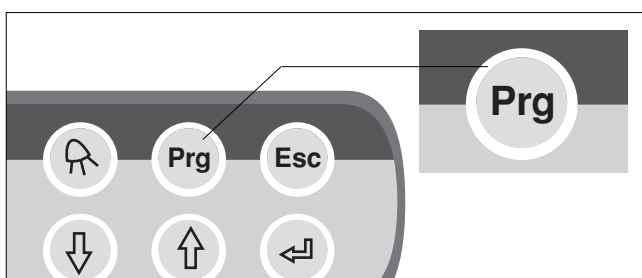

After inserting the password the Prg key can be used to enter the menus for editing the unit operating parameters.

The unit operating parameters are divided into two sub-menus:

- USER menu
- MAINTENANCE MAN menu
- MANUFACTURER menu
- SETPOINT menu
- CLOCK menu
- INPUT/OUTPUT menu

CONTROL AND DISPLAY PARAMETERS

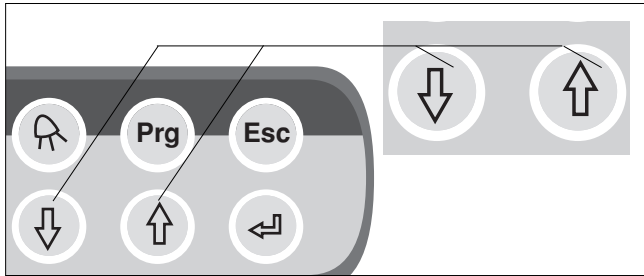

Click on the scrolling selectors to display the current status of the machine

STATUS SCREEN

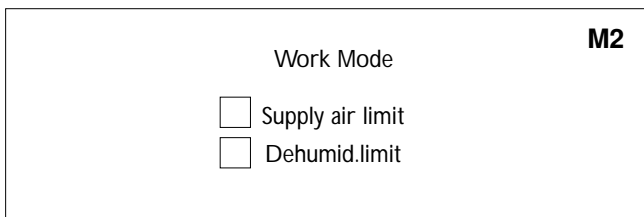
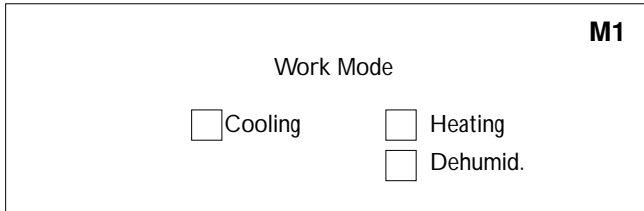
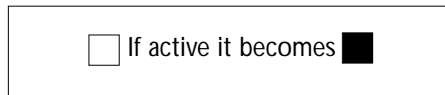
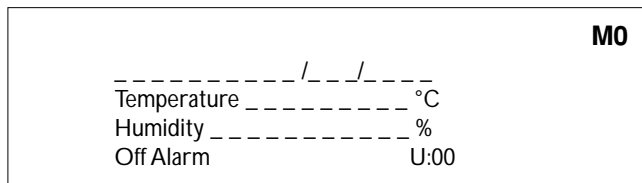

Parameters menu

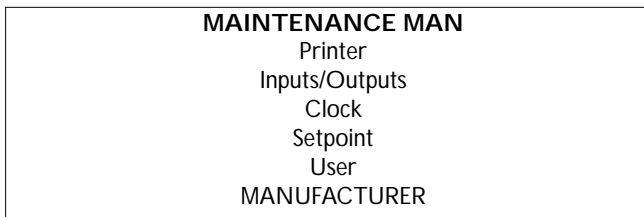

Click on the parameters menu to access the following sub-menus:

To enter the Maintenance Man menu:

- Using the scrolling selectors position on MAINTENANCE MAN and click the enter key

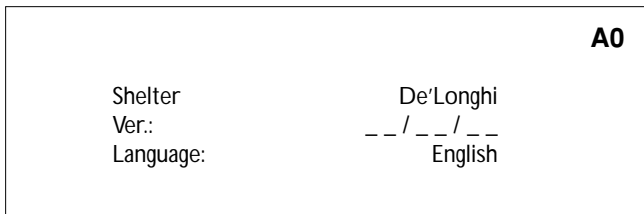

Display page with the software version, date and language

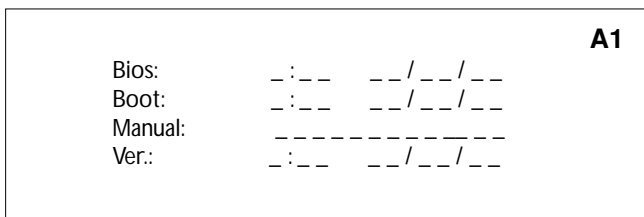

Display page with the bios, Boot, Manual and software version

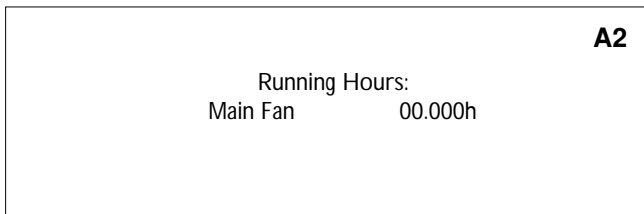

Display page with the hours of operation of the main fan

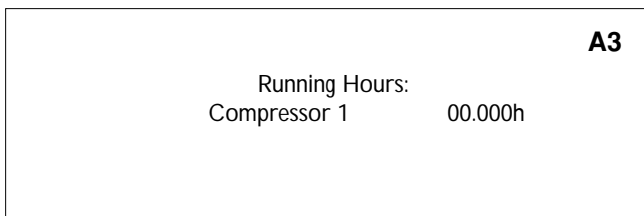

Display page with the hours of operation of compressor 1

A4
press alarm key for record

Press the alarm warning key to display all the stored alarms displayed in the time period.
Range H001-H999

A5
Maintenance man password 0000

Select the password with the scrolling selectors to access the menu for setting the maintenance parameters.
Factory value 123
Range 0+9999

A6
Change of hours of operation Fan Compress 1 Compress 2

The mask A6 can be used to change the hours of operation of the delivery fan, compressor 1 and compressor 2.
Factory value 0
Range 0÷99 . 0÷999
Unit of measurement Hours.

A7
Limit of hours of operation (x1000) Fan 99 Comp1 99 Humidify 99 Comp2 99

The mask A7 can be used to change the thresholds of the hours of operation of the devices.
Factory value 99
Range 0÷99
Unit of measurement Hours x 100

A8
Sensor offset Humidity _ _ _ % Transducer _ _ _ bar Pressure2 _ _ _ bar

The display page A8 can be used to calibrate the pressure sensor.
Factory value 0

A8
Sensor offset Ambient temp. 00:0°C External temp. 00:0°C Delivery temp. 00:0°C

The display page A9 can be used to calibrate the sensor: ambient temperature, external temperature and delivery temperature.
Factory value 0
Range -9.9÷9.9
Unit of measurement °C

Aa
Sensor offset Condens. temp. _ _ _ °C Cond. temp.2 _ _ _ °C

The mask Aa can be used to calibrate the condensation temperature sensor 1 and the condensation temperature sensor 2.
Factory value 0
Range -9,9 ÷ 9,9
Unit of measurement °C

Ab
Manual procedure Digit. output 01 Off Digit. output 02 Off Digit. output 03 Off

The mask Ab is used for manual activation of the digital outputs 1-2-3.
Factory value Off.
Range Off ÷ On

Ac
Manual procedure Digit. output 04 Off Digit. output 05 Off

The mask Ac is used for manual activation of the digital outputs 4-5.
Factory value Off.
Range Off ÷ On

		Ad
Manual procedure		
Digit. output 06	Off	
Digit. output 07	Off	
Digit. output 07	Off	

The mask Ad is used for manual activation of the digital outputs 6-7-8.
Factory value Off.
Range Off ÷ On

		Ae
Manual procedure		
Digit. output 09	Off	
Digit. output 10	Off	
Digit. output 11	Off	

The mask Ae is used for manual activation of the digital outputs 9-10-11.
Factory value Off.
Range Off ÷ On

		Af
Manual procedure		
AUT analog	00.0V	
AUT analog	00.0V	

The mask Af is used for manual activation of the modulating outputs 1-2.
Factory value 0.
Range 0 ÷ 10
Unit of measurement Volt

		Ag
Manual procedure		
AUT analog	00.0V	
Aout 04 AUT	00.0V	

The mask Ag is used for manual activation of the modulating outputs 3-4.
Factory value 0.
Range 0 ÷ 10
Unit of measurement Volt

		AI
New password maintenance	0123	

The display page A1 is used to change the maintenance man password. Select the required combination with the scrolling selectors and confirm with the enter key.
Factory value 1234
Range 0÷9999

MAINTENANCE MAN
Printer
Inputs/Outputs
Clock
Setpoint
User
MANUFACTURER

Click on the Esc key to return to the main display page.
To access the main menu, click on the programming key.
To enter the Printer menu, position on PRINTER with the scrolling selectors and click on the enter key.
The printer is optional.

MAINTENANCE MAN
Printer
Inputs/Outputs
Clock
Setpoint
User
MANUFACTURER

Click on the Esc key to return to the main display page.
To access the main menu, click on the programming key.
To enter the Inputs/Outputs menu, position on Inputs/Outputs with the scrolling selectors and click on the enter key.

Analog input:	IO
Pr1 - bar	___°C
Pr2 - bar	___°C
Amb. humidity	___%

Pressure trasducer reading valve

Analog input:	I1
Amb. temp.	___°C
Ext. temp.	___°C
Deliv. temp.	___%

The display page shows the value of the ambient temperature, external temperature and supply air.

12	
Analog inputs	
Cond. temp.1	----°C
Cond. temp.2	----°C

The display page I2 shows the gas condensation temperature

13	
Digit. inputs 1-3	
C1 low pressure	-0-
Alarm C1	-0-
Heat. el. TCO 1	-0-

The display page I3 shows the status of the digital inputs 1-3

14	
Digit. inputs 4-6	
Air flow	-0-
Air filter	-0-
Blackout	-0-

The display page I4 shows the status of the digital inputs 4-6

15	
Digit. inputs 7-8	
fire/smoke	-0-
fan TCO	-0-

The display page I5 shows the status of the digital inputs 7-8

16	
Digit. inputs 9-10	
C2 low press.	-0-
Alarm C2	-0-
Heat. el. TCO2	-0-

The display page I6 shows the status of the digital inputs 9-10

17	
Digit. input 12	
Aux. alarm	-0-

The display page I7 shows the status of the digital input 12

18	
Analog output	
Damper	00.0V
Fan	00.0V

The display page I8 shows the value of the Damper and the Fan

19	
Analog output	
Cond. fan 1	00.0 V
Cond. fan.	00.0 V

The display page I9 shows the value of the cond. fan 1 and Cond. fan 2

Ia	
Digit. outputs	analog Ia
Deliv. fan	Off
Compressor 1	Off
Heat. el. 1	Off

The display page Ia shows the status of the digital outputs 1-3

Ib	
Digit. outputs	4-5:
Serious alarm	Off
Alarm 1	Off

The display page Ib shows the status of the digital outputs 4-5

Ic	
Digit. outputs	6-8: Ic
Alarm 2	Off
Open damper	Off
Closed damper	Off

The display page Ic shows the status of the digital outputs 6-8

Id	
Digit. outputs	9-11:
Compressor 2	--
Heat. el. 2	--
Humidif	--

The display page Id shows the status of the digital outputs 9-11

MAINTENANCE MAN Printer Inputs/Outputs Clock Setpoint User MANUFACTURER
--

Click on the Esc key to return to the main display page. To access the main menu, click on the programming key. To enter the Clock menu, position on Clock with the scrolling selectors and click on the enter key.

KO	
clock adj.	
Time	--
Date	_ / _ / _
Day	-----

The display page KO is used to adjust the time and date

MAINTENANCE MAN
Printer
Inputs/Outputs
Clock
Setpoint
User
MANUFACTURER

Click on the Esc key to return to the main display page.
 To access the main menu, click on the programming key.
 To enter the Setpoint menu, position on Setpoint with the scrolling selectors and click on the enter key.

Visual setpoint	SO
Temperature	---.°C
Humidity	---.-%

The display page SO shows the temperature set point and humidity.

	SI
Temperature	---.°C
Humidity	---.-%

The display page S1 is used to change the temperature set point and humidity

Offset	S2
Freecooling	---.°C
Freec.enable	Yes/No

The display page S2 is used to change the damper offset value.

Unit of measurement °C

The display page S2 is used to enable or disable the damper Yes/No

MAINTENANCE MAN
Printer
Inputs/Outputs
Clock
Setpoint
User
MANUFACTURER

Click on the Esc key to return to the main display page.
 To access the main menu, click on the programming key.
 To enter the User menu, position on User with the scrolling selectors and click on the enter key.

Password	PO
User	0000

Select the password with the scrolling selectors to access the menu for setting the maintenance parameters.

Factory value 1234

Range 0 ÷ 9999

Setpoint limit	PI
Temperature:	
Min.	---.°C
Max.	---.°C

The mask P1 is used to change the temperature setpoint minimum and maximum limit.

Range -99.9 ÷ 99.9

Unit of measurement °C.

Setpoint limit	P2
Humidity:	
Min.	---.-%
Max.	---.-%

The mask P2 is used to change the Humidity setpoint minimum and maximum limit.

Range -99.9 ÷ 99.9

Unit of measurement °C.

Temperature	P3
Coll diff.	---.°C
Heat diff.	---.°C
Neutral zone	---.°C

The mask P3 is used to change:

a) The Heating and Cooling proportional temperature bands

Range -0 ÷ 100

Unit of measurement °C.

b) The neutral temperature zone

Range -0 ÷ 99.9

Unit of measurement °C.

	P4
Dehumid. Band	---.-%

The mask P4 is used to change the Dehumidifying bands

Range -0 ÷ 100

P5
 Freecooling DT --.-- °C

The mask P5 is used to change the delta between the internal and external temperature in the Freecooling mode.
 Range 0 ÷ 10
 Unit of measurement °C.

Freecool Humid P6
 Limit Enable :Yes/No
 Min. --.-- %
 Max. --.-- %

Min and Max Humidity Set Point limits for Freecooling activation.

P7
 Kejboard on/off Yes/No

The mask P7 is used to change the ON-OFF enable from keyboard
 Range No ÷ Yes

Temp. Alarm P8
 Low offset --.-- °C
 High offset --.-- °C
 HHHigh offset --.-- °C

The mask P8 is used to change the low and high offset and maximum ambient temperature alarms
 Range -999.9 ÷ 999.9
 Unit of measurement °C.

Humidy Alarm P9
 Low offset --.-- °C
 High offset --.-- °C

The mask P9 is used to change the low and high offset for humidity alarm.

Temp. supply air Pa
 Sensor enable: Yes/no
 Setpoint --.-- °C
 Differenz --.-- °C

The mask Pa is used to change:
 a) the delivery limit function enable
 Range No ÷ Yes
 b) the Setpoint and the Differential of the air delivery for the limitation.
 Range -999.9 ÷ 999.9
 Unit of measurement °C

Sel. alarm type Pb
 S=ser. 1/2 = Light1/2
 A01:11111 A06:11111
 A11:11111 A16:11111

The mask Pb shows the alarm binary codes.

Sel. alarm type Pc
 S=ser. 1/2 = Light1/2
 A21:11111 A26:11111
 A31:11111 A37:11111

The mask Pc shows the alarm binary codes.

Sel. alarm type Pd
 S=ser. 1/2 = Light1/2
 A41:11111 A46:11111
 A51:11111

The mask Pd shows the alarm binary codes.

Identif. No. Pe
 for BMS Network: 001
 Comm.speed: --.-- bps
 Protocol type

The mask Pe can be used:
 a) to change the identification number of the supervision network board.
 range 0 ÷ 200
 b) the baud rate of the supervision network board.
 range 1200 ÷ 19200
 Unit of measurement baud rate
 c) the protocol.
 range Carel, Modbus, Lon, Rs232, Gsm

Maintenance man Ph	Used to change the maintenance man password. Select the required combination with the scrolling selectors and confirm with the enter key.
user	0000

<p>MAINTENANCE MAN</p> <p>Printer</p> <p>Inputs/Outputs</p> <p>Clock</p> <p>Setpoint</p> <p>User</p> <p>MANUFACTURER</p>

Click on the Esc key to return to the main display page. To access the main menu, click on the programming key. To enter the Manufacturer menu, position on Manufacturer with the scrolling selectors and click on the enter key.

ZO	Select the password with the scrolling selectors to access the menu for setting the maintenance parameters.
Manufacturer password	0000
	Factory value 0012
	Range 0 ÷ 9999

Select the password with the scrolling selectors to access the menu for setting the maintenance parameters. Factory value 0012 Range 0 ÷ 9999

The MANUFACTURER menu

<p>Configuration</p> <p>Parameters</p> <p>Carel EXV Driver</p> <p>Timing</p> <p>Initialization</p>

Insert the password to access the manufacturer menu.

Use the scrolling selectors to position on Manufacturer and click on the enter key.

BMS Network:Y/N CO	The mask CO can be used to change:
Print: Y/N	a) Enabling of the BMS
Select of temp. °C / F	Range N ÷ Y
	b) Enabling of the printer
	Range N ÷ Y
	c) Unit of measurement of the sensors and the temperature parameters from Celsius to Fahrenheit
	Range °C ÷ F

The mask CO can be used to change:
a) Enabling of the BMS
Range N ÷ Y
b) Enabling of the printer
Range N ÷ Y
c) Unit of measurement of the sensors and the temperature parameters from Celsius to Fahrenheit
Range °C ÷ F

Refrigerant: ___ CI	The mask C1 can be used to change:
Freecooling: _____	a) Type of refrigerant
Compressor together	Range R22,0R134a,R404a, R407C, R410A.
Greecooling: Y/N	b) Type of Freecooling
	Range 0 ÷ 10V 3 points
	c) Enabling of simultaneous freecooling and compressor operation
	Range N ÷ Y

The mask C1 can be used to change:
a) Type of refrigerant
Range R22,0R134a,R404a, R407C, R410A.
b) Type of Freecooling
Range 0 ÷ 10V 3 points
c) Enabling of simultaneous freecooling and compressor operation
Range N ÷ Y

Dehumid. : ___ C2	The mask C2 is used to enable the humidifying or dehumidifying function
	Range Y ÷ N

The mask C2 is used to enable the humidifying or dehumidifying function
Range Y ÷ N

	C3
Compressors:	1
Heat. el. No.	1

The mask C3 is used to change (for pC020medium only) the number:

a) of compressors
Factory value 1
Range 1 ÷ 2

b) of heating elements
Factory value 1
Range 1 ÷ 2 Binar

	C4
Enable modulation Delivery fan	Yes

The display page C4 is used to enable the modulating delivery fan.
Factory value Yes
Range Yes ÷ No

	C5
condensation:	Yes
Coil: No. of fans	Single 1

the mask C5 is used to enable:

a) condensation function
Factory value YES
range YES-NO

b) second condensation coil
Factory value single
Range Single -Double

The mask C5 can be used to change the number of condensation fans (for pc02medium only)
factory value 1
Range 1 ÷ 2

	C7
Configuration Analog input Pressure circ.	1 1

The display page C7 is used to configure the analog input 1.
Factory value circuit 1 press.
Range Press/Temp.

	C8
Configuration Analog input Circ. pressure	3 2

The display page C8 is used to configure the analog input 2.
Factory value circuit 2press.
Range Press/Temp.

	C9
Press. sensor	1:Y
Type	Current
Min. thresh.	00.0bar
Max. thresh.	30.0bar

The mask C9 is used to:

a) enable the pressure sensor 1
Factory value Y
Range Y ÷ N

b) select the type of signal of the pressure sensor 1.
Factory value Current
Range 0÷1 , 0÷10V, Current

c) change the minimum and maximum value measured by the pressure sensor 2 (for pC02medium only)
Factory value 0.0 / 30.0
Range -20 ÷ 50. Unit of measurement bar

	Ca
Press. sensor	2:Y
Type	Current
Min. thresh.	00.0bar
Max. thresh.	30.0bar

The mask Ca is used to:

- enable the pressure sensor 2 (for pC02medium only)
Factory value Y
Range Y ÷ N
- set the value of the pressure sensor 2 signal (for pC02medium only).
Factory value Current
Range 0÷1 , 0÷10V, Current
- change the minimum and maximum value measured by the pressure sensor 2 (for pC02medium only)
Factory value 0.0 / 30.0
Range -20 ÷ 50. Unit of measurement bar

	Cc
Humidity probe	Y/ N
Type	_ :_V
Threshold min.	_____%
Threshold max	_____%

The mask Cc enables the humidity sensor (not pC01xs)
Range Y ÷ N
Enabling the sensor with the Y command permits

- changing of the minimum and maximum value measured by the humidity sensor (not pC01xs)
Factory value 0.0 / 100.0
Range 0 ÷ 100
Unit of measurement %r.h.:
- changing the type of humidity sensor signal (not pC01xs)
Factory value 0-10V
Range 0÷1 , 0÷10V, Current

	Cd
Temperature probe	
Type	-----
Supply air probe	Yes / No
Type	-----

The mask Cd is used to:

- select the type of ambient temperature sensor signal.
Range NTC÷PT1000
- enable the delivery sensor.
Range Yes÷No
- select the type of ambient temperature sensor signal.
Range NTC ÷ PT1000

	Ce
Ext. temp. sensor:	Y / N
Type	-----

The mask Ce is used to:

- enable the external temperature sensor.
Range Y ÷ N
- select the type of external temperature sensor signal.
Range NTC ÷ PT1000

	Ci
Air Flow Al.	-----
Filter Al.	-----
Compres Al.	-----

Digital OutPut configuration
Normally open or close

OutPut Config.	C1
Free Al.	-----
Ht / Fan Al.	-----
Lt / Comp Al.	-----

Digital OutPut configuration
Normally open or closed

OutPut 5-6 Config.	Cm
Dout 5	N-T AL.:
Dout 6	N-T AL.:

Digital OutPut 5 - 6 configuration
5:- High temperature alarm
or
- Main fan status
6:- Low temperature alarm
or
- Compressor status

Configuration Parameters Carel EXV Driver Delay times Initialization

Click on the Esc key to return to the Manufacturer menu.

To enter the Parameters menu, use the scrolling selectors to position on Parameters and click on the enter key.

	G1
Regulation Type	-----

The mask G1 is used to select the type of temperature regulation:
Range prop ÷ P+1

Freecooling	G2
Min	---- %
Max	---- %
Min. aperture	---- V

The mask G2 is used to set:

a) the percentage of the freecooling minimum aperture proportional band.
Range 0.0 ÷ 100.0

b) the percentage of the freecooling maximum aperture proportional band.
Range 0.0 ÷ 100.0

c) the minimum freecooling aperture.
Range 0.0 ÷ 100.0
Unit of measurement Volt

Modulating Fan Speed	G3
Min Speed	---- V
Max Speed	---- V
Deum Speed	---- V

Modulating Fan speed Screen

Modulating Fan Speed	G4
(Stop deumidif.):	
Differential	---- °C
OffSet	---- °C

Low Temperature limits Screen for Dehumidification

Pressure probe	G5
High Press.	---- bar
Differ. HP	---- °C

High pressure probe set point for condenser fan modulation

Condensation	G6
Setpoint	---- bar
Different.	---- bar
Speedup time	---- sec

The mask G7 is used to set:

a) the condensation setpoint (temperature).
Range -99.9 ÷ 99.9
Unit of measurement °C/°F

b) the condensation differential (temperature).
Range -99.9 ÷ 99.9
Unit of measurement °C/°F

c) the condensation modulating fan speed-up time.
Range 0 ÷ 99
Unit of measurement Seconds

Condensation Fan	G8
Max speed	---- V
Min speed	---- V

The mask G8 is used to set the minimum and maximum speed of the modulating condensation fans
Range 00.0 ÷ 10.0
Unit of measurement Volt

H.P. cond. prevent	G9
Enable	No / Yes
Setpoint	---- bar
Different.	---- bar

The mask Ga is used to:

a) enable the high pressure alarm prevent function.
Range No ÷ Yes
Unit of measurement °C/°F

b) set the Prevent function temperature setpoint (temperature).
Range -99.9 ÷ 99.9
Unit of measurement °C/°F

c) set the Prevent function temperature differential (temperature).
Range -99.9 ÷ 99.9
Unit of measurement °C/°F

Configuration Parameters Carel EXV Driver Delay times Initialization

Click on the Esc key to return to the Manufacturer menu.
To enter the Delay times menu, use the scrolling selectors to position on Delay times and click on the enter key.

Timing	T0
Start fan	---- sec
Dealy time	---- sec
Stop fan	---- sec

The display page T0 is used to set the delay of the delivery fan start-up
Range 0 ÷ 999
Unit of measurement seconds

	T1
Integr. time	
Only P+1	0600 sec
Opening time	3p
Damper	____sec

the display page T1 is used to set:

- a) the integration time for P+I temperature regulation
Factory value 600
Range 0 ÷ 9999
Unit of measurement seconds
- b) freecooling 3-point swing time
Factory value 180
Range 0 ÷ 9999
Unit of measurement seconds

	T2
Low pressure alarm delay	0240sec
High-low Temp./Hum. alarm display	0180sec

the display page T2 is used to set:

- a) the low pressure alarm delay
Factory value 240
Range 0 ÷ 9999
Unit of measurement seconds
- b) the high-low temperature-humidity alarm delay
Factory value 180
Range 0 ÷ 9999
Unit of measurement seconds

	T3
Serious alarm delay (rel.4)	000sec
Minor 1 (rel.5)	000sec
Minor 2 (rel.6)	000sec

The display page T3 is used to set:

- a) the Serious alarm relay trip delay.
Factory value 0
Range 0 ÷ 999
Unit of measurement seconds
- b) the Minor alarm 1 relay 5 trip delay.
Factory value 0
Range 0 ÷ 999
Unit of measurement seconds
- b) the Minor alarm 2 relay 6 trip delay.
Factory value 0
Range 0 ÷ 999
Unit of measurement seconds

	T4
Filter alarm delay	0020sec
Air flow alarm delay	0020 sec

The display page T4 can be used to set the delay of the dirty filter and air flow status alarms.

Factory value 20
Range 0 ÷ 9999
Unit of measurement seconds

	T5
Compressor alarm delay	01080 sec
Compressor min. time	on 0000 sec

the display page T5 can be used to set the minimum duration of compressor switching off and on.

Factory value 180/0
Range 0 ÷ 9999
Unit of measurement seconds

	T6
Compressor time btwn on-on	0360sec
Diff. compressor start time	0010 sec

the display page T6 is used to set:

- a) the delay between compressor starts
Factory value 360
Range 0 ÷ 9999
Unit of measurement seconds
- b) the minimum delay between the start-up of different compressors
Factory value 0
Range 0 ÷ 9999
Unit of measurement seconds

Time off freec. **T7**
 For humid.
 limit _ _ _ min

The display page T7 is used to set the freecooling off time due to high humidity limit
 Range 0 ÷ 999
 Unit of measurement seconds

Delay alarm **T10**
 Freecooling _ _ _ _ sec

the display page T10 is used to set:
 Range 0 ÷ 9999
 Unit of measurement seconds

Configuration
 Parameters
 Carel EXV Driver
 Delay times
Initialization

Click on the Esc key to return to the Manufacturer menu.

 To enter the Initialization menu, use the scrolling selectors to position on Initialization and click on the enter key.

Insert Password **V0**
 To install default param.
 value 0000

The display page V0 is used to reinstall default parameters..
 Range 0 ÷ 9999

Story reset **V1**
 alarm Yes / No

The display page V1 can be used to delete the alarm records
 Range No ÷ Yes

Set default
 values
 Switch off unit
 to confirm

Switch off the unit to confirm the set default values.

New manufacturer **V2**
 password 0000

The display page V0 is used to set the password .
 Range 0 ÷ 9999

The representation to the side shows the necessary connection for setting up the pLAN network between the 2 units.

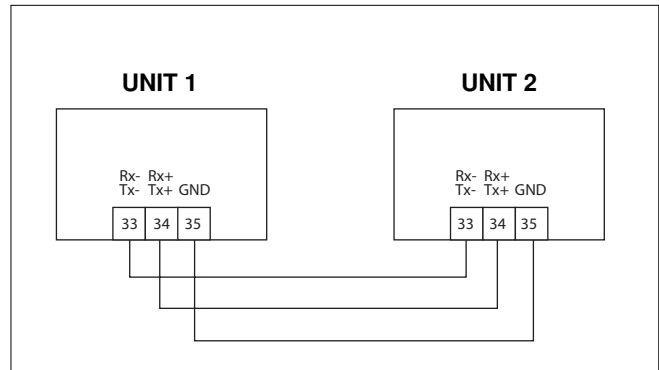

ADDRESSING AND MANAGEMENT OF CONNECTIONS BETWEEN BOARDS (pLAN)

The pLAN network distinguishes a physical connection between pCO2 boards. The boards must be addressed for the network to operate correctly. If the same address is assigned to two elements in the network, pLAN will not work!

How to assign the addresses

Set the pLAN addresses with binary logic by changing the position of a bank of dip switches located on the pCO2 (top left); THE BOARDS MUST NOT BE POWERED. The addresses to be set on the two pLAN machines are given below.

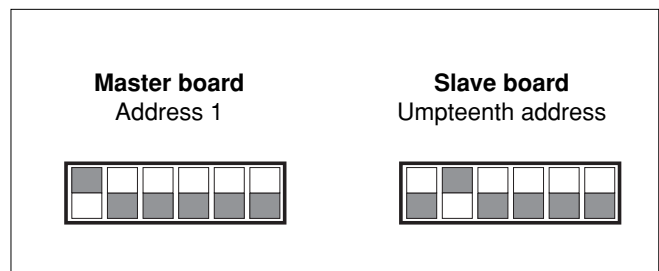

MASTER means the main control unit, while the SLAVE is the service unit that activates in support of the master. The address of the unit is indicated in the bottom right corner of the pCO2 main mask.

Example of use of plan networks

A pLAN network connection makes it possible to carry out the following functions

- balancing of the hours of operation between the shelter units by rotation of the stand-by units.
- switching on of the stand-by units if other units are off due to serious alarm or black-out.
- switching on of the stand-by units to compensate excessive heat load.

pLAN software configuration operations are carried out on the board configured as **Master**.

Maintenance man
Printer
Inputs/Outputs
Clock
Setpoint
User
MANUFACTURER

Click on the Esc key to return to the main display page.

To access the main menu, click on the programming key. To enter the Manufacturer menu, position on Manufacturer with the scrolling selectors and click on the enter key.

Z0
Manufacturer password
0000

Select the password with the scrolling selectors to access the menu for setting the maintenance parameters.
Factory value: 1234
Range: 0÷9999

The MANUFACTURER menu

CONFIGURATION
Parameters
Carel EXV Driver
Delay times
Initialization

Insert the password to access the manufacturer menu. Use the scrolling selectors to position on CONFIGURATION and click on the enter key.

Cf
Unit configuration
U1: present - rotation
U2: present - rotation
U3: not present

The mask Cf, which only activates for pLAN configuration, is used to define the class of participation in pLAN of boards 1-3
Factory value: present-no rotation
Range: present-rotation/present-no rotation/not present.
“Set the configurations according to the enclosed display page”

Cg
Unit configuration
U4: not present
U5: not present
U6: not present

The mask Cg, which only activates for pLAN configuration, is used to define the class of participation in pLAN of boards 4-6
Factory value: present-no rotation
Range: present-rotation/present-no rotation/not present.
“Set the configurations according to the enclosed display page”

Ch
Unit configuration
U7: not present
U8: not present

The mask Ch, which only activates for pLAN configuration, is used to define the class of participation in pLAN of boards 7-8
Factory value: present-no rotation
Range: present-rotation/present-no rotation/not present.
“Set the configurations according to the enclosed display page”

CONFIGURATION
Parameters
Carel EXV Driver
Delay times
Initialization

Click on the ESC key to return to the MANUFACTURER menu.

To enter the PARAMETERS menu, position on PARAMETERS with the scrolling selectors and click on the enter key.

Gb

Unit rotation
unit in stand-by: 1
Rotation time: 024h

The mask Gb, which only activates in the plan mode, is used to define:

- a) number of units set in the stand-by mode
Factory value: 0
Range: 0÷1
- b) automatic rotation interval of units in pLAN network
Factory value: 24
Range: 1÷240

“Set the configurations according to the enclosed display page”

Gc

Unit forced
for temperature: YES
Low temp. delay: 003
High temp. delay: 003

The mask Gc, which only activates in the plan mode, is used to define:

- a) enabling of support in cooling/heating of unit in pLAN network
Factory value: YES
Range: YES-NO
- b) forcing delays for low and high ambient temperature
Factory value: 003/003
Range: 000÷999

“Set the configurations according to the enclosed display page”

Gd

Unit forced
for low temperature
Difference: 008.0°C
Offset: 04.0°C

The mask Gd, which only activates in the plan mode, is used to define:

- a) the low ambient temperature differential for forcing network units:
Factory value: 8.0°C
Range: 0.0÷99.9°C
- b) the low ambient temperature offset for forcing network units:
Factory value: 4.0°C
Range: 0.0÷99.9°C

“Set the configurations according to the enclosed display page”

Ge

Unit forced
for high temperature
Difference: 008.0°C
Offset: 04.0°C

The mask Ge, which only activates in the plan mode, is used to define:

- a) the high ambient temperature differential for forcing network units:
Factory value: 8.0°C
Range: 0.0÷99.9°C
- b) the high ambient temperature offset for forcing network units:
Factory value: 4.0°C
Range: 0.0÷99.9°C

“Set the configurations according to the enclosed display page”

PROBLEM	CAUSE	REMEDY
The fan does not activate	Mains power failure	Check presence of power
		Check fuse on terminal block
	On-off switch on "Off"	Put to "On"
	Faulty room control	Check room control
	Faulty fan	Check fan motor
Insufficient cooling	Obstructed mesh filter	Clean the filter
	Obstructed air flow	Remove the obstacles
	Room control regulation	Check room control
	Incorrect water temperature	Check
	Presence of air	Bleed
Noise and vibration	Contact between metal parts	Check
	Loose screws	Tighten the screws



Via L.Seitz, 47
310100 Treviso Italia
Tel. 0422 4131 - Telefax 0422 413659
www.delonghi.com