

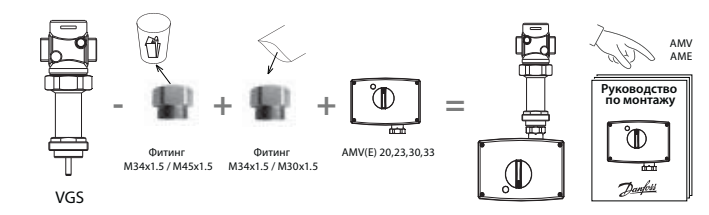

Инструкция

VG, VGF, VGS, VGU, VGUF

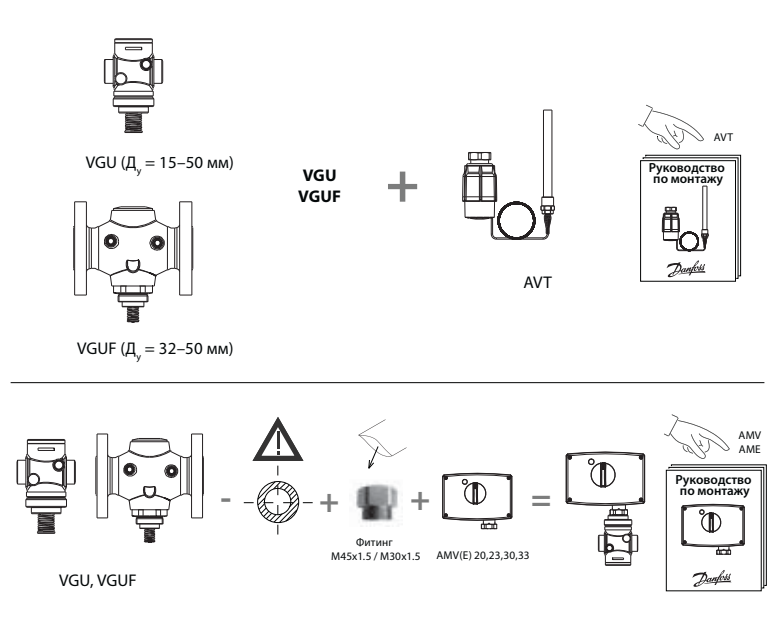
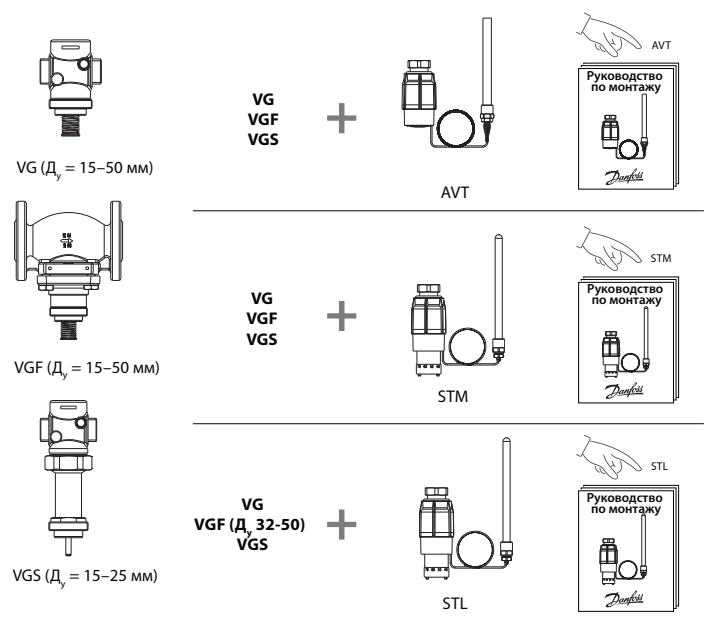

HO VG, VGF, VGS

H3 VGU, VGUF

Тип	P _y	T _{max} (°C)	T _{min} (°C)
VG	25	150	2
VGF	25	150	2
VGS	25	200	2
VGU	25	150	2
VGUF	25	150	2

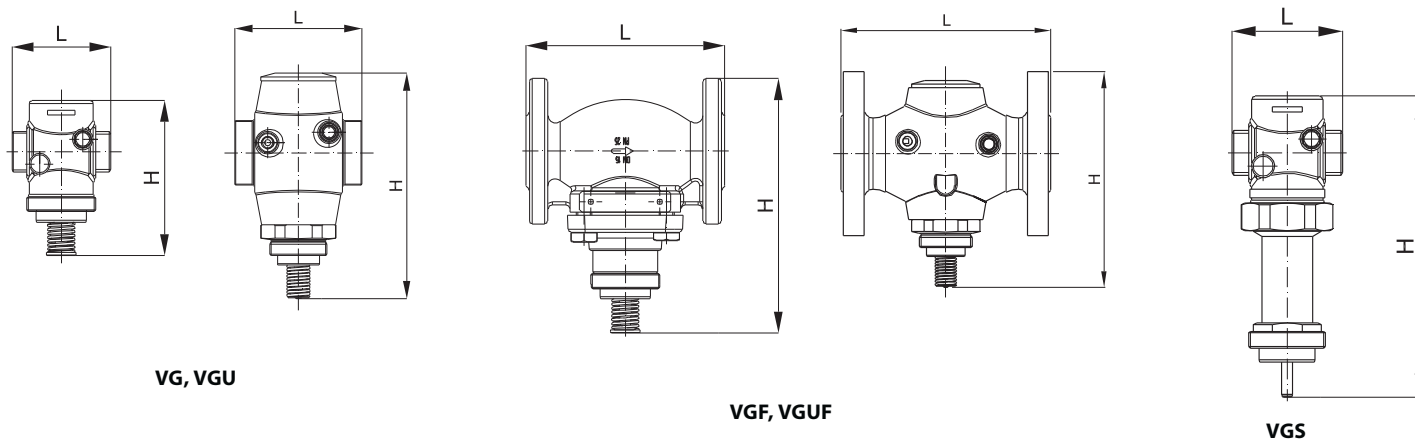

Д _в , мм		15	20	25	32	40	50
VG	L	65	70	75	100	110	130
	H	102	102	102	176	176	176
VGF	L	130	150	160	180	200	230
	H	165	172	175	184	189	196
VGS	L	65	70	75	-	-	-
	H	176	176	179	-	-	-
VGU	L	65	70	75	100	110	130
	H	105	105	107	173	173	173
VGUF	L	-	-	-	180	200	230
	H	-	-	-	180	185	193

Примечание: другие размеры фланцев — смотри таблицу для фитингов.

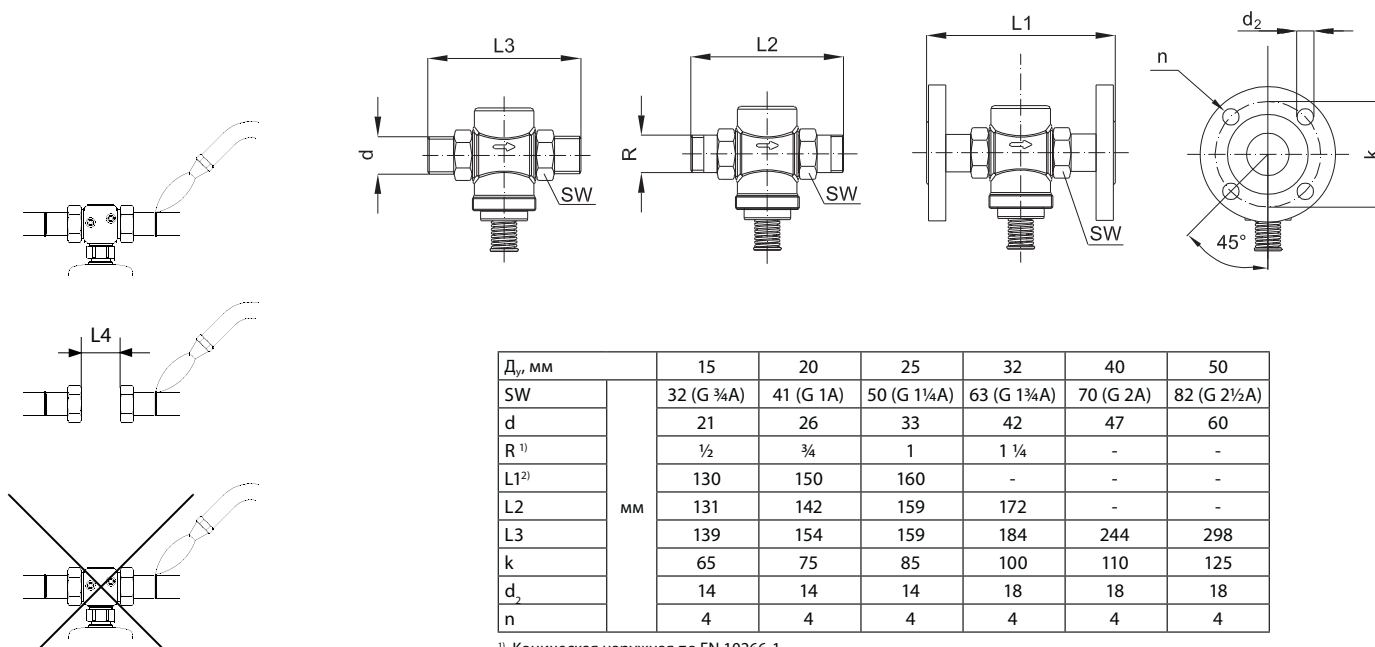

Д _в , мм	15	20	25	32	40	50
SW	32 (G ¾A)	41 (G 1A)	50 (G 1¼A)	63 (G 1¾A)	70 (G 2A)	82 (G 2½A)
d	21	26	33	42	47	60
R ¹⁾	½	¾	1	1 ¼	-	-
L1 ²⁾	130	150	160	-	-	-
L2	131	142	159	172	-	-
L3	139	154	159	184	244	298
k	65	75	85	100	110	125
d ₂	14	14	14	18	18	18
n	4	4	4	4	4	4

¹⁾ Коническая наружная по EN 10266-1.

²⁾ Фланцы P_y 25, по EN 1092-2.

В соответствии с EN 1092-2, EN 1092-3

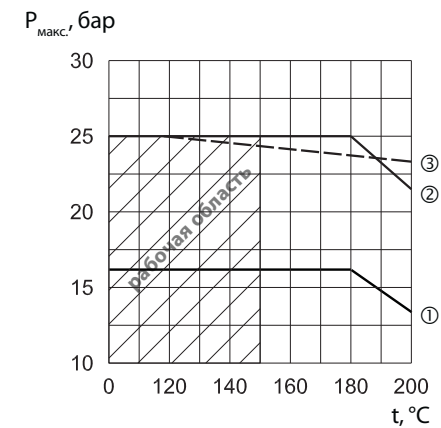

- ① CuSn5ZnPb (Rg5) P_y 16
- ② CuSn5ZnPb (Rg5) P_y 25
- ③ EN-GJS-400-18-LT (GGG 40.3) P_y 25