

technical data



Fan coil units

FWV-FWL-FWM

FWD

FWB

technical data



Fan coil units

FWV-FWL-FWM

FWD

FWB

Cooling only



Heating only

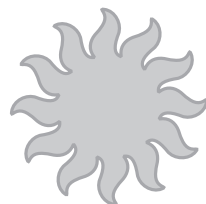

Heat pump



Fan coil units

Low wall / Flexi type unit	1	FWV-FWL-FWM 4	1
Duct Unit.....	2	FWD 42	2
Small Duct Unit.....	3	FWB 80	3

TABLE OF CONTENTS

FWV-FWL-FWM

1	Features	5
2	Specifications	6
	Nominal capacity and nominal input	6
	Technical Specifications	7
	Electrical Specifications	9
3	Options	10
4	Control systems	12
5	Capacity tables	13
	Cooling capacity tables - 2-pipe	13
	Cooling capacity tables - 4-pipe	17
	Capacity tables with glycol for process cooling applications	21
	Heating capacity tables - 2-pipe	22
	Heating capacity tables - 4-pipe	24
	Power consumption - 2-pipe	26
	Power consumption - 4-pipe	28
	Capacity correction factor	30
6	Dimensional drawing & centre of gravity	31
	Dimensional drawing	31
7	Wiring diagram	33
	Wiring diagram	33
8	Sound data	34
	Sound level data	34
9	Installation	36
	Installation method	36
10	Operation range	38
11	Hydraulic performance	39
	Water pressure drop curve evaporator cooling 2-pipe	39
	Water pressure drop curve evaporator heating 2-pipe	39
	Water pressure drop curve evaporator heating 4-pipe	40

1 Features

- Quick fixing system for wall mounting
- Pre-assembled 3-way/4-port ON/OFF valves are available
- Valve packages are insulated, no extra drain pan required
- Valve packages contain balancing valves and sensor pocket
- Fast-on connections for electrical options : no tools needed
- Quick removal of washable filter
- Electrical heater : no relay up to 2kw capacity
- Electrical heater : equipped with two overheat cut-out thermostats



1

1

2 Specifications

2-1 NOMINAL CAPACITY AND NOMINAL INPUT			FWV-L-M 01CATN/TV	FWV-L-M 02CATN/TV	FWV-L-M 03CATN/TV	FWV-L-M 04CATN/TV	FWV-L-M 06CATN/TV	FWV-L-M 08CATN/TV	FWV-L-M 10CATN/TV	
Power Input	High		W	37	53	56	98	98	182	244
	Medium		W	28	36	43	61	68	127	169
	Low		W	21	24	29	38	47	86	109
Cooling capacity	Total capacity	High	kW	1.54	2.09	2.93	4.33	4.77	6.71	8.02
		Medium	kW	1.24	1.81	2.38	3.27	3.87	5.27	6.24
		Low	kW	1.04	1.45	1.76	2.51	3.17	3.97	4.11
	Sensible capacity	High	kW	1.20	1.51	2.11	3.15	3.65	4.91	5.96
		Medium	kW	0.97	1.31	1.70	2.45	2.92	3.83	4.63
		Low	kW	0.79	1.05	1.26	1.80	2.32	2.84	3.05
Heating capacity (2-pipe)	High		kW	2.14	2.57	3.81	5.63	6.36	7.83	10.03
	Medium		kW	1.73	2.18	3.08	4.30	5.21	6.23	7.80
	Low		kW	1.43	1.79	2.28	3.29	4.24	4.77	5.24

2-1 NOMINAL CAPACITY AND NOMINAL INPUT			FWV-L-M 01CAFN/FV	FWV-L-M 02CAFN/FV	FWV-L-M 03CAFN/FV	FWV-L-M 04CAFN/FV	FWV-L-M 06CAFN/FV	FWV-L-M 08CAFN/FV	FWV-L-M 10CAFN/FV	
Power Input	High		W	37	53	56	98	98	182	244
	Medium		W	28	36	43	61	68	127	169
	Low		W	21	24	29	38	47	86	109
Cooling capacity	Total capacity	High	kW	1.46	1.90	2.87	4.33	4.67	6.64	7.88
		Medium	kW	1.24	1.62	2.33	3.27	3.81	5.23	6.16
		Low	kW	0.99	1.35	1.73	2.48	3.11	3.93	4.07
	Sensible capacity	High	kW	1.14	1.51	2.07	3.15	3.57	4.85	5.85
		Medium	kW	0.97	1.25	1.66	2.45	2.87	3.80	4.57
		Low	kW	0.75	1.10	1.24	1.78	2.28	2.82	3.02
Heating capacity (4-pipe)	High		kW	1.90	2.10	3.08	5.05	5.30	7.91	9.30
	Medium		kW	1.70	1.78	2.68	4.25	4.65	6.83	7.95
	Low		kW	1.50	1.56	2.18	3.60	4.04	5.69	6.12

2 Specifications

2-2 TECHNICAL SPECIFICATIONS				FWV-L-M 01CATN/TV	FWV-L-M 02CATN/TV	FWV-L-M 03CATN/TV	FWV-L-M 04CATN/TV	FWV-L-M 06CATN/TV	FWV-L-M 08CATN/TV	FWV-L-M 10CATN/TV	
Dimensions	Unit - FWV	Height	mm	564	564	564	564	564	564	564	
		Width	mm	774	774	984	1194	1194	1404	1404	
		Depth	mm	226	226	226	226	226	251	251	
	Unit - FWL	Height	mm	564	564	564	564	564	564	564	
		Width	mm	774	774	984	1194	1194	1404	1404	
		Depth	mm	226	226	226	226	226	251	251	
	Unit - FWM	Height	mm	535	535	535	535	535	535	535	
		Width	mm	584	584	794	1004	1004	1214	1214	
		Depth	mm	224	224	224	224	224	249	249	
Weight	Machine weight - FWV		kg	19	20	25	30	31	41	41	
	Machine weight - FWL		kg	20	21	27	32	33	44	44	
	Machine weight - FWM		kg	14	15	19	23	23	32	32	
Material			Plastic + sheet metal								
Colour			Plastic and metal RAL9010								
Sound level	Sound power	High	dB(A)	45	50	47	52	56	61	66	
		Medium	dB(A)	39	44	41	43	49	54	59	
		Low	dB(A)	33	38	33	35	43	47	49	
Water flow	Cooling		l/h	265	359	504	745	820	1154	1343	
	Heating		l/h	265	359	504	745	820	1154	1343	
Water pressure drop	Cooling		kPa	13	13	11	12	14	12	19	
	Heating		kPa	9	11	9	9	10	9	16	
Fan	Type			Centrifugal multi-blade, double suction							
	Air flow rate	High	m ³ /h	319	344	442	706	785	1011	1393	
		Medium	m ³ /h	233	271	341	497	605	771	1022	
		Low	m ³ /h	178	211	241	361	470	570	642	
	Speed			3 steps : high, medium, low							
Quantity			1	1	2	2	2	2	2		
Motor	Type			Closed induction, B class insulation, winding thermal cut-out							
Standard heat exchanger	Rows		mm	2	3	3	3	3	3	3	
	Stages		mm	10	10	10	10	10	12	12	
	Fin pitch		mm	1.8	1.6	1.6	1.8	1.6	2.1	2.1	
	Face area		m ²	0.086	0.086	0.138	0.191	0.191	0.292	0.292	
	Water volume		l	0.5	0.7	1	1.4	1.4	2.1	2.1	
Air filter			Plastic								
Insulation material			Class 1 self-extinguishing								
Vibration insulation			Rubber ring for fan motor								
Water connections	Std. heat exchanger		inch	1/2	1/2	1/2	1/2	1/2	3/4	3/4	
Drain			mm	16	16	16	16	16	16	16	
Notes			Cooling capacity is based on room temperature 27° CDB, 19° CWB and entering water temperature 7°C, water temperature rise 5K.								
			Heating capacity is based on: room temperature 20° CDB and entering water temperature 50° C, water flow rate as during cooling.								
			Air flow at 0 Pa ESP								

1

2

2 Specifications

2-2 TECHNICAL SPECIFICATIONS				FWV-L-M 01CAFN/FV	FWV-L-M 02CAFN/FV	FWV-L-M 03CAFN/FV	FWV-L-M 04CAFN/FV	FWV-L-M 06CAFN/FV	FWV-L-M 08CAFN/FV	FWV-L-M 10CAFN/FV	
Dimensions	Unit - FWV	Height	mm	564	564	564	564	564	564	564	
		Width	mm	774	774	984	1194	1194	1404	1404	
		Depth	mm	226	226	226	226	226	251	251	
	Unit - FWL	Height	mm	564	564	564	564	564	564	564	
		Width	mm	774	774	984	1194	1194	1404	1404	
		Depth	mm	226	226	226	226	226	251	251	
	Unit - FWM	Height	mm	535	535	535	535	535	535	535	
		Width	mm	584	584	794	1004	1004	1214	1214	
		Depth	mm	224	224	224	224	224	249	249	
Weight	Machine weight - FWV		kg	20	21	26	32	33	44	44	
	Machine weight - FWL		kg	21	22	28	34	35	46	46	
	Machine weight - FWM		kg	15	16	20	25	25	34	34	
Material			Plastic + sheet metal								
Colour			Plastic and metal RAL9010								
Sound level	Sound power	High	dBA	45	50	47	52	56	61	66	
		Medium	dBA	39	44	41	43	49	54	59	
		Low	dBA	33	38	33	35	43	47	49	
Water flow	Cooling		l/h	251	327	494	745	803	1142	1355	
	Heating		l/h	196	182	286	396	465	694	816	
Water pressure drop	Cooling		kPa	13	13	11	12	14	12	19	
	Heating		kPa	7	8	5	10	10	8	9	
Fan	Type			Centrifugal multi-blade, double suction							
	Air flow rate	High	m³/h	307	327	431	690	763	998	1362	
		Medium	m³/h	225	261	332	490	593	765	1007	
		Low	m³/h	174	205	238	356	460	565	636	
	Speed			3 steps : high, medium, low							
Quantity			1	1	2	2	2	2	2		
Motor	Type			Closed induction, B class insulation, winding thermal cut-out							
Standard heat exchanger	Rows		mm	2	3	3	3	3	3	3	
	Stages		mm	10	10	10	10	10	12	12	
	Fin pitch		mm	1.8	1.6	1.6	1.8	1.6	2.1	2.1	
	Face area		m²	0.086	0.086	0.138	0.191	0.191	0.292	0.292	
	Water volume		l	0.5	0.7	1	1.4	1.4	2.1	2.1	
Additional heat exchanger	Rows		mm	1	1	1	1	1	1	1	
	Stages		mm	8	8	8	8	8	10	10	
	Fin pitch		mm	1.6	1.6	1.6	1.6	1.6	1.6	1.6	
	Face area		m²	0.068	0.068	0.11	0.152	0.152	0.243	0.243	
	Water volume		l	0.2	0.2	0.3	0.4	0.4	0.6	0.6	
Air filter			Plastic								
Insulation material			Class 1 self-extinguishing								
Vibration insulation			Rubber ring for fan motor								
Water connections	Std. heat exchanger		inch	1/2	1/2	1/2	1/2	1/2	3/4	3/4	
Drain			mm	16	16	16	16	16	16	16	
Notes			Rating conditions cooling 4 pipe : air 27								
			Rating conditions heating 4 pipe : air 20								
			Air flow at 0 Pa ESP								

2 Specifications

2-3 ELECTRICAL SPECIFICATIONS			FWV-L-M 01CATN/TV	FWV-L-M 02CATN/TV	FWV-L-M 03CATN/TV	FWV-L-M 04CATN/TV	FWV-L-M 06CATN/TV	FWV-L-M 08CATN/TV	FWV-L-M 10CATN/TV
Current input	High	A	0.17	0.24	0.25	0.44	0.43	0.80	1.12
	Medium	A	0.13	0.16	0.20	0.29	0.31	0.57	0.79
	Low	A	0.10	0.11	0.14	0.19	0.22	0.40	0.55
Required power supply	V / f / Hz	230/1/50							
Required fuses	A	0.5	0.5	0.5	0.5	0.5	1	2	
Required wire section	mm ²	1	1	1	1	1	1	1	1
Notes			The power consumption for the valve motor is 5W (peak) only during opening						
			For more details concerning conditional connections, see http://www.daikineurope.com , select E-data Books. Finally click on the document title of your choice						

2-3 ELECTRICAL SPECIFICATIONS			FWV-L-M 01CAFN/FV	FWV-L-M 02CAFN/FV	FWV-L-M 03CAFN/FV	FWV-L-M 04CAFN/FV	FWV-L-M 06CAFN/FV	FWV-L-M 08CAFN/FV	FWV-L-M 10CAFN/FV
Current input	High	A	0.17	0.24	0.25	0.44	0.43	0.80	1.12
	Medium	A	0.13	0.16	0.20	0.29	0.31	0.57	0.79
	Low	A	0.10	0.11	0.14	0.19	0.22	0.40	0.55
Required power supply	V / f / Hz	230/1/50							
Required fuses	A	0.5	0.5	0.5	0.5	0.5	1	2	
Required wire section	mm ²	1	1	1	1	1	1	1	1
Notes			The power consumption for the valve motor is 5W (peak) only during opening						
			For more details concerning conditional connections, see http://www.daikineurope.com , select E-data Books. Finally click on the document title of your choice						

1

2

3 Options

FWV - FWL - FWM	F2	F4	F6	F8	F9	F10	F11	FWV	FWL	FWM	Notes/remarks
Additional single-row heat exchanger	ESRH02A6	ESRH03A6	ESRH03A6	ESRH06A6	ESRH06A6	ESRH10A6	ESRH10A6	X	X	X	Cannot be used in combination with electric heater
Electric heater	EEH01A6	EEH02A6	EEH03A6	EEH06A6	EEH06A6	EEH10A6	EEH10A6	X	X	X	Cannot be used in combination with additional HFE requires electronic controller
2-pipe ON-OFF 3 way motor driven valve complete with mounting kit	E2MV02A6	E2MV03A6	E2MV03A6	E2MV06A6	E2MV06A6	E2MV10A6	E2MV10A6	X	X	X	Requires electronic controller or electromechanical controller
4-pipe ON-OFF 3 way motor driven valve complete with mounting kit	E4MV02A6	E4MV03A6	E4MV03A6	E4MV06A6	E4MV06A6	E4MV10A6	E4MV10A6	X	X	X	Requires electronic controller
Fan stop thermostat	YF5TA6			YF5TA6				X	X	X	
Air intake & discharge grill + front filter fixing kit for concealed models	EADF02A6	EADF02A6	EADF03A6	EADF06A6	EADF06A6	EADF10A6	EADF10A6	X	X	X	
Supporting feet (feet (= supporting brackets + covers))	ESFV02A6	ESFV02A6	ESFV03A6	ESFV06A6	ESFV06A6	ESFV10A6	ESFV10A6	X	X	X	Covers can not be used for FWM
Supporting feet + grill	EFV02A6	EFV02A6	EFV03A6	EFV06A6	EFV06A6	EFV10A6	EFV10A6	X	X	X	
Fresh air intake louvers (manual)	EFA02A6	EFA02A6	EFA3A6	EFA6A6	EFA6A6	EFA10A6	EFA10A6	X	X	X	
Rear panel for vertical mounted models	ERP02A6	ERP02A6	ERP03A6	ERP06A6	ERP06A6	ERP10A6	ERP10A6	X	X	X	Only for vertical mounted units
Controller electro mechanical built in	ECFWM0B6			ECFWM0B6				X	X	X	
Controller electrical built in + water probe	ECFWE0B6			ECFWE0B6				X	X	X	Water probe included
Controller electrical remote + water probe	ECFWE0R6			ECFWE0R6				X	X	X	Water probe included
Power interface for connection of up to 4 FCU to a single control panel	EPIMS0A6			EPIMS0A6				X	X	X	
Vertical drain pan	EDPY0A6			EDPY0A6				X	X	X	
Horizontal drain pan	EDPHA6			EDPHA6				X	X	X	

4TW60019-2A (Sheet 1/2)











3 Options











1
3

FWV	Additional single-row heat exchanger	Electric heater	2-pipe ON-OFF 3 way motor driven valve complete with mounting kit	4-pipe ON-OFF 3 way motor driven valve complete with mounting kit	Fan stop thermostat	Air intake & discharge grill + front filter fixing kit for concealed models	Supporting feet (= supporting brackets + covers)	Supporting feet + grill	Fresh air intake louvers (manual)	Rear panel for vertical mounted models	Controller electro-mechanical built in	Controller electronic remote + water probe	Power interface for connection of up to 4 FCU to a single control panel	Vertical drain pan	Horizontal drain pan
	ESRH.A6	EEH.A6	E2MV.A6	E4MV.A6	YFSTA6	EADFA6	ESRV.A6	ESFVG.A6	EFA.A6	ERPVA6	ECFVMB6	ECFVWER6	EPVMSA6	EDPVA6	EDPHA6
Additional single-row heat exchanger	ESRH.A6			X			X		X	X		X	X	X	X
Electric heater		EEH.A6					X		X	X		X	X	X	X
2-pipe ON-OFF 3 way motor driven valve complete with mounting kit			E2MV.A6				X		X	X		X	X	X	X
4-pipe ON-OFF 3 way motor driven valve complete with mounting kit				E4MV.A6			X		X	X		X	X	X	X
Fan stop thermostat					YFSTA6		X		X	X		X	X	X	X
Air intake & discharge grill + front filter fixing kit for concealed models					EADFA6		X		X	X		X	X	X	X
Supporting feet feet (= supporting brackets + covers)							ESRV.A6		X	X		X	X	X	X
Supporting feet + grill								ESFVG.A6	X	X		X	X	X	X
Fresh air intake louvers (manual)									EFA.A6	X		X	X	X	X
Rear panel for vertical mounted models									ERPVA6	X		X	X	X	X
Controller electro-mechanical built in									ECFVMB6	X		X	X	X	X
Controller electronic remote + water probe									ECFVWER6	X		X	X	X	X
Power interface for connection of up to 4 FCU to a single control panel									EPVMSA6	X		X	X	X	X
Vertical drain pan									EDPVA6	X		X	X	X	X
Horizontal drain pan									EDPHA6	X		X	X	X	X

4TW60019-2A (Sheet 2/2)

4 Control systems

	Cool/heat changeover			Options		Basic control functions		Control features		
										
2-pipe	X					X	X	X	X	
	X			X		X	X		X	
	X				X	X	X	X	X	
	X			X	X	X	X		X	
		X				X	X	X		
		X		X		X	X			
			X		X	X	X	X	X	X
4-pipe	X			X		X	X		X	
	X					X	X	X	X	
			X			X	X	X		X
			X	X		X	X		X	X

-  Manual cool/heat changeover.
-  Automatic cool/heat changeover based on water temperature.
-  Automatic cool/heat changeover based on air temperature.
-  Control of the 3-way/4pipe ON/OFF valve. The water valve shut-off once the desired temperature is reached.
-  The controller controls the electric heater as integration or replacement of the hot water heating system. When the operating mode selector switch is turned on "electric heater" and the electric heater is turned on, the fan runs continuously at medium speed. When the operating mode selector switch is turned to "electric heater" and the electric heater is turned on, the fan runs continuously at medium speed.
-  The fan speed can be set at one of the 3 speeds (low, medium or maximum) by turning the operation mode selector.
-  The fan speed is switched automatically based on the difference between the temperature set on the thermostat and the room temperature.
-  Optimised comfort cooling. When the fan coil has reached the desired setpoint, the fan will operate at medium speed and at regular intervals to ensure constant room temperature and lower sound.
-  The controller prevents the fan coil unit from operating in one mode, if the required water temperature is not achieved to operate in the selected mode.
-  The dead zone is a temperature interval close to the set temperature. When the air is warmer/cooler than the top/lower limit of the neutral zone, the cooling/heating mode is selected.

5 Capacity tables

5 - 1 Cooling capacity tables - 2-pipe

1
5

Air temperature (°C DB - °C WB) Water temperature (Entering °C - leaving °C)		22 - 16						8 - 13						9 - 14										
		6 - 11			7 - 12			8 - 13			9 - 14			6 - 11			7 - 12			8 - 13			9 - 14	
Model	Total cooling capacity W	Sensible cooling capacity W	Water flow ℓ/h	Water pressure drop kPa	Total cooling capacity W	Sensible cooling capacity W	Water flow ℓ/h	Water pressure drop kPa	Total cooling capacity W	Sensible cooling capacity W	Water flow ℓ/h	Water pressure drop kPa	Total cooling capacity W	Sensible cooling capacity W	Water flow ℓ/h	Water pressure drop kPa	Total cooling capacity W	Sensible cooling capacity W	Water flow ℓ/h	Water pressure drop kPa	Total cooling capacity W	Sensible cooling capacity W	Water flow ℓ/h	Water pressure drop kPa
FW 01 TW/TV	Max.	880	840	152	5	820	820	140	4	730	730	4	650	650	111	3	650	650	111	3	650	650	111	3
	Med.	720	720	124	4	660	660	114	3	610	610	3	550	550	95	2	490	490	84	2	490	490	84	2
	Min.	640	570	110	3	580	580	100	2	540	540	2	490	490	84	2	490	490	84	2	490	490	84	2
FW 02 TW/TV	Max.	1290	1070	221	6	1090	1090	187	4	980	980	4	880	880	151	3	860	860	148	3	790	790	135	2
	Med.	1120	930	192	5	880	830	151	3	860	860	3	790	790	135	2	790	790	135	2	790	790	135	2
	Min.	910	750	157	3	780	700	133	2	730	730	2	670	670	114	2	670	670	114	2	670	670	114	2
FW 03 TW/TV	Max.	1730	1470	296	5	1480	1480	255	3	1370	1370	3	1260	1260	216	3	1260	1260	216	3	1260	1260	216	3
	Med.	1450	1200	249	3	1260	1120	216	3	1180	1180	2	1080	1080	186	2	1080	1080	186	2	1080	1080	186	2
	Min.	1240	960	213	3	1090	890	186	2	920	820	1	860	860	149	1	860	860	149	1	860	860	149	1
FW 04 TW/TV	Max.	2480	2170	425	5	2140	2140	368	4	1970	1970	3	1810	1810	310	3	1810	1810	310	3	1810	1810	310	3
	Med.	1990	1740	341	3	1720	1630	295	2	1620	1620	2	1490	1490	256	2	1490	1490	256	2	1490	1490	256	2
	Min.	1750	1360	300	3	1520	1270	261	2	1290	1170	1	1230	1230	212	1	1230	1230	212	1	1230	1230	212	1
FW 06 TW/TV	Max.	2820	2570	484	6	2390	2390	410	4	2120	2120	3	1930	1930	331	3	1930	1930	331	3	1930	1930	331	3
	Med.	2150	1990	369	4	1980	1980	340	3	1830	1830	3	1670	1670	287	2	1670	1670	287	2	1670	1670	287	2
	Min.	1960	1650	336	3	1700	1550	292	2	1590	1590	2	1460	1460	250	2	1460	1460	250	2	1460	1460	250	2
FW 08 TW/TV	Max.	3850	3380	661	5	3290	3290	565	4	3040	3040	3	2780	2780	478	3	2780	2780	478	3	2780	2780	478	3
	Med.	3140	2680	539	3	2720	2510	467	3	2570	2570	2	2360	2360	405	2	2360	2360	405	2	2360	2360	405	2
	Min.	2730	2130	469	3	2380	1990	409	2	2010	1840	1	1940	1940	333	1	1940	1940	333	1	1940	1940	333	1
FW 10 TW/TV	Max.	4790	4200	822	8	4000	4000	687	6	3550	3550	5	3120	3120	536	4	3120	3120	536	4	3120	3120	536	4
	Med.	3380	3120	579	4	3130	3130	538	4	2890	2890	3	2650	2650	455	3	2650	2650	455	3	2650	2650	455	3
	Min.	2770	2270	474	3	2400	2120	412	2	2170	2170	2	1990	1990	342	2	1990	1990	342	2	1990	1990	342	2

4TW60012-1A (Sheet 1/13)

5 Capacity tables

5 - 1 Cooling capacity tables - 2-pipe

Air temperature (°C DB - °C WB) Water temperature (Entering °C - leaving °C)		25 - 18																			
		6 - 11				7 - 12				8 - 13				9 - 14							
Model		Total cooling capacity		Water flow		Water pressure drop		Total cooling capacity		Water flow		Water pressure drop		Total cooling capacity		Water flow		Water pressure drop			
		W	kW	ℓ/h	kPa	W	kW	ℓ/h	kPa	W	kW	ℓ/h	kPa	W	kW	ℓ/h	kPa	W	kW	ℓ/h	kPa
FW 01 TIV/V	Max.	1480	1110	254	13	1260	1030	217	9	1020	810	175	6	920	740	158	5	920	740	158	5
	Med.	1190	900	205	9	1010	830	174	6	810	680	139	4	740	620	126	4	740	620	126	4
	Min.	1000	740	172	6	850	670	145	5	680	610	117	3	620	500	107	3	620	500	107	3
FW 02 TIV/V	Max.	2020	1410	346	13	1750	1300	300	10	1450	1190	250	7	1120	1060	193	4	1120	1060	193	4
	Med.	1750	1230	300	10	1520	1130	260	8	1260	1030	217	6	970	920	167	3	970	920	167	3
	Min.	1400	980	240	7	1210	910	208	5	1000	820	172	4	820	750	141	3	820	750	141	3
FW 03 TIV/V	Max.	2820	1970	484	11	2440	1820	419	8	2010	1640	345	6	1660	1660	284	4	1660	1660	284	4
	Med.	2290	1590	393	7	1970	1460	338	6	1590	1310	273	4	1320	1200	226	3	1320	1200	226	3
	Min.	1690	1180	290	4	1460	1080	251	3	1300	1020	224	3	1140	950	196	2	1140	950	196	2
FW 04 TIV/V	Max.	4170	2940	715	12	3590	2710	617	9	2940	2450	504	6	2440	2440	418	4	2440	2440	418	4
	Med.	3140	2280	538	7	2670	2090	458	5	2080	1860	357	3	1880	1880	322	3	1880	1880	322	3
	Min.	2390	1670	410	4	2060	1540	354	3	1830	1440	315	3	1600	1350	274	2	1600	1350	274	2
FW 06 TIV/V	Max.	4600	3400	788	14	3970	3150	682	10	3280	2880	562	7	2690	2690	463	5	2690	2690	463	5
	Med.	3720	2720	639	9	3200	2510	549	7	2580	2270	443	5	2160	2160	371	4	2160	2160	371	4
	Min.	3040	2160	522	7	2580	1970	444	5	2050	1760	352	3	1780	1660	306	3	1780	1660	306	3
FW 08 TIV/V	Max.	6470	4590	1109	11	5590	4230	960	9	4590	3830	788	6	3730	3730	640	4	3730	3730	640	4
	Med.	5060	3580	868	7	4320	3270	741	6	3360	2890	578	4	2850	2690	489	3	2850	2690	489	3
	Min.	3780	2640	649	4	3230	2410	554	3	2870	2270	492	3	2500	2120	429	2	2500	2120	429	2
FW 10 TIV/V	Max.	7730	5560	1325	19	6690	5150	1148	15	5540	4700	951	10	4520	4520	776	7	4520	4520	776	7
	Med.	6000	4320	1030	12	5150	3980	885	9	4160	3590	714	6	3460	3460	595	5	3460	3460	595	5
	Min.	3920	2830	672	6	3270	2570	561	4	2900	2420	498	3	2520	2280	433	3	2520	2280	433	3

4TW60012-1A (Sheet 3/13)

5 Capacity tables

5 - 1 Cooling capacity tables - 2-pipe

Air temperature (°C DB - °C WB) Water temperature (Entering °C - leaving °C)		27 - 19						9 - 14									
		6 - 11			7 - 12			8 - 13			9 - 14						
Model	Total cooling capacity W	Sensible cooling capacity W	Water flow ℓ/h	Water pressure drop kPa	Total cooling capacity W	Sensible cooling capacity W	Water flow ℓ/h	Water pressure drop kPa	Total cooling capacity W	Sensible cooling capacity W	Water flow ℓ/h	Water pressure drop kPa	Total cooling capacity W	Sensible cooling capacity W	Water flow ℓ/h	Water pressure drop kPa	
FW 01 TIV/TV	Max	1750	1280	301	17	1540	1200	264	13	1310	1120	10	1090	1090	188	7	
	Med.	1410	1040	242	12	1240	970	213	9	1060	900	7	880	880	151	5	
	Min.	1180	850	203	9	1040	790	179	7	890	730	152	5	710	122	3	
FW 02 TIV/TV	Max	2350	1610	403	16	2090	1510	359	13	1810	1400	10	1510	1290	260	8	
	Med.	2030	1400	348	13	1810	1310	311	10	1570	1220	8	1320	1120	226	6	
	Min.	1630	1120	279	9	1450	1050	249	7	1260	970	216	5	1050	890	180	4
FW 03 TIV/TV	Max	3290	2260	564	14	2930	2110	503	11	2540	1950	9	2110	1790	362	6	
	Med.	2670	1820	459	10	2380	1700	408	8	2060	1570	353	6	1680	1420	289	4
	Min.	1990	1360	341	6	1760	1260	302	5	1500	1150	258	4	1320	1080	227	3
FW 04 TIV/TV	Max	4870	3370	835	15	4330	3150	743	12	3750	2920	643	10	3090	2670	530	7
	Med.	3690	2620	632	9	3270	2450	561	8	2800	2260	481	6	2230	2050	383	4
	Min.	2850	1950	489	6	2510	1800	431	5	2100	1640	361	3	1860	1540	319	3
FW 06 TIV/TV	Max	5360	3890	919	18	4770	3650	818	14	4140	3400	710	11	3430	3140	589	8
	Med.	4350	3120	747	12	3870	2920	664	10	3340	2710	574	8	2730	2480	469	5
	Min.	3570	2490	613	9	3170	2320	544	7	2710	2140	466	5	2150	1920	370	4
FW 08 TIV/TV	Max	7520	5250	1289	15	6710	4910	1152	12	5830	4560	1001	9	4830	4170	829	7
	Med.	5930	4110	1016	10	5270	3830	904	8	4530	3530	778	6	3630	3190	624	4
	Min.	4510	3070	774	6	3970	2840	681	5	3310	2570	569	4	2910	2420	500	3
FW 10 TIV/TV	Max	9000	6350	1544	25	8020	5960	1376	20	6960	5560	1196	16	5800	5120	995	11
	Med.	7020	4950	1204	16	6240	4630	1071	13	5390	4300	924	10	4400	3930	756	7
	Min.	4690	3290	804	8	4110	3050	706	6	3430	2780	588	5	2940	2600	505	3

4TW60012-1A (Sheet 5/13)

5 Capacity tables

5 - 1 Cooling capacity tables - 2-pipe

Air temperature (°C DB - °C WB) Water temperature (Entering °C - leaving °C)		30 - 22											
		6 - 11			7 - 12			8 - 13			9 - 14		
Model		Total cooling capacity W	Water flow ℓ/h	Water pressure drop kPa	Total cooling capacity W	Water flow ℓ/h	Water pressure drop kPa	Total cooling capacity W	Water flow ℓ/h	Water pressure drop kPa	Total cooling capacity W	Water flow ℓ/h	Water pressure drop kPa
FW 01 TIV/V	Max.	2640	453	35	2440	1450	419	30	2240	1370	2020	1290	21
	Med.	2120	364	24	1960	1170	337	21	1800	1110	1630	1050	15
	Min.	1770	304	17	1640	960	282	15	1510	910	1360	860	11
FW 02 TIV/V	Max.	3430	589	32	3190	1820	548	28	2940	1730	2680	1630	20
	Med.	2940	505	25	2740	1580	471	22	2530	1500	2310	1410	16
	Min.	2360	404	17	2200	1270	377	15	2030	1200	1860	1130	11
FW 03 TIV/V	Max.	4770	818	27	4450	2550	764	24	4110	2410	3760	2280	17
	Med.	3880	665	19	3620	2070	621	16	3350	1960	3060	1840	12
	Min.	2890	495	11	2700	1550	463	10	2500	1460	2290	1370	7
FW 04 TIV/V	Max.	7110	1220	30	6630	3800	1137	26	6120	3600	5580	3400	19
	Med.	5400	926	18	5030	2960	864	16	4650	2810	4240	2650	12
	Min.	4190	719	12	3910	2230	671	10	3620	2110	3300	1980	8
FW 06 TIV/V	Max.	7810	1340	34	7280	4350	1249	30	6720	4130	6130	3910	22
	Med.	6350	1090	24	5920	3510	1016	21	5470	3330	4990	3140	15
	Min.	5220	895	17	4870	2820	836	15	4500	2670	4110	2520	11
FW 08 TIV/V	Max.	10880	1867	29	10160	5900	1743	25	9400	5600	8600	5280	19
	Med.	8610	1478	19	8040	4650	1381	17	7440	4400	6810	4150	12
	Min.	6630	1137	12	6190	3520	1062	11	5730	3320	5230	3120	8
FW 10 TIV/V	Max.	13100	2246	48	12230	7120	2098	42	11280	6160	11110	6840	29
	Med.	10270	1762	31	9570	5580	1642	27	8840	5290	8680	5320	19
	Min.	6950	1193	16	6480	3750	1112	14	5980	3550	5850	3540	9

4TW60012-1A (Sheet 7/13)

5 Capacity tables

5 - 2 Cooling capacity tables - 4-pipe

1
5

Air temperature (°C DB - °C WB) Water temperature (Entering °C - leaving °C)		22 - 16						8 - 13						9 - 14									
		6 - 11			7 - 12			8 - 13			9 - 14			6 - 11			7 - 12			8 - 13			9 - 14
Model		Total cooling capacity W	Sensible cooling capacity W	Water flow ℓ/h	Water pressure drop kPa	Total cooling capacity W	Sensible cooling capacity W	Water flow ℓ/h	Water pressure drop kPa	Total cooling capacity W	Sensible cooling capacity W	Water flow ℓ/h	Water pressure drop kPa	Total cooling capacity W	Sensible cooling capacity W	Water flow ℓ/h	Water pressure drop kPa	Total cooling capacity W	Sensible cooling capacity W	Water flow ℓ/h	Water pressure drop kPa		
FW 01 FV/FV	Max.	850	850	146	5	770	770	132	4	690	690	118	3	620	620	107	3	620	620	107	3		
	Med.	670	640	116	3	620	620	107	3	570	570	98	2	520	520	90	2	470	470	81	2		
	Min.	620	550	107	3	560	560	96	2	520	520	89	2	470	470	81	2	470	470	81	2		
FW 02 FV/FV	Max.	1160	1080	199	6	990	990	170	5	900	900	154	4	810	810	140	3	720	720	124	3		
	Med.	980	890	167	5	860	860	148	4	790	790	136	3	720	720	124	3	630	630	108	2		
	Min.	870	740	149	4	740	690	127	3	690	690	118	2	630	630	108	2	630	630	108	2		
FW 03 FV/FV	Max.	1680	1430	289	4	1460	1460	251	3	1350	1350	232	3	1240	1240	213	2	1240	1240	213	2		
	Med.	1440	1180	246	3	1250	1100	214	3	1160	1160	199	2	1070	1070	183	2	1070	1070	183	2		
	Min.	1230	950	211	3	1080	880	185	2	910	810	157	1	850	850	147	1	850	850	147	1		
FW 04 FV/FV	Max.	2420	2120	415	4	2110	2110	363	4	1950	1950	335	3	1790	1790	307	3	1790	1790	307	3		
	Med.	1980	1720	339	3	1710	1610	294	2	1610	1610	276	2	1480	1480	254	2	1480	1480	254	2		
	Min.	1740	1350	298	3	1510	1260	260	2	1280	1160	220	1	1220	1220	210	1	1220	1220	210	1		
FW 06 FV/FV	Max.	2750	2500	471	5	2330	2330	400	4	2070	2070	356	3	1900	1900	326	3	1900	1900	326	3		
	Med.	2140	1960	367	4	1960	1960	336	3	1810	1810	310	3	1660	1660	284	2	1660	1660	284	2		
	Min.	1940	1630	334	3	1690	1520	289	2	1570	1570	269	2	1440	1440	247	2	1440	1440	247	2		
FW 08 FV/FV	Max.	3790	3330	650	5	3270	3270	561	3	3020	3020	518	3	2760	2760	475	3	2760	2760	475	3		
	Med.	3130	2660	537	3	2710	2490	465	2	2560	2560	439	2	2350	2350	403	2	2350	2350	403	2		
	Min.	2720	2120	467	3	2370	1970	407	2	2010	1820	344	1	1930	1930	331	1	1930	1930	331	1		
FW 10 TV/TV	Max.	4690	4120	803	7	3990	3990	674	5	3480	3480	597	4	3090	3090	530	3	3090	3090	530	3		
	Med.	3360	3090	576	4	3110	3110	533	3	2870	2870	492	3	2630	2630	451	2	2630	2630	451	2		
	Min.	2750	2260	472	3	2390	2110	410	2	2160	2160	370	2	1980	1980	340	1	1980	1980	340	1		

4TW60012-1A (Sheet 2/13)

5 Capacity tables

5 - 2 Cooling capacity tables - 4-pipe

Air temperature (°C DB - °C WB) Water temperature (Entering °C - leaving °C)		25 - 18														
		6 - 11				7 - 12				8 - 13				9 - 14		
Model	Total cooling capacity W	Sensible cooling capacity W	Water flow ℓ/h	Water pressure drop kPa	Total cooling capacity W	Sensible cooling capacity W	Water flow ℓ/h	Water pressure drop kPa	Total cooling capacity W	Sensible cooling capacity W	Water flow ℓ/h	Water pressure drop kPa	Total cooling capacity W	Sensible cooling capacity W	Water flow ℓ/h	Water pressure drop kPa
FW 01 FWFV	1400	1060	241	11	1190	980	205	9	960	880	165	6	870	870	149	5
	1100	840	188	7	930	770	159	6	740	700	127	4	680	680	116	3
	950	700	163	6	800	640	138	4	660	590	113	3	600	600	103	3
FW 02 FWFV	1830	1400	315	14	1590	1300	272	11	1310	1200	226	8	1110	1110	190	6
	1560	1160	268	10	1350	1080	231	8	1110	990	191	6	940	940	161	4
	1300	950	223	8	1120	870	192	6	920	790	158	4	780	740	134	3
FW 03 FWFV	2770	1930	474	10	2390	1780	410	8	1970	1610	337	6	1620	1620	278	4
	2240	1560	384	7	1930	1420	330	5	1550	1270	266	4	1300	1180	224	3
	1660	1160	285	4	1450	1070	249	3	1290	1000	222	3	1130	940	194	2
FW 04 FWFV	4100	2890	703	11	3530	2660	606	9	2880	2410	494	6	2390	2390	411	4
	3100	2250	532	7	2630	2060	452	5	2070	1840	355	3	1860	1860	320	3
	2360	1650	405	4	2050	1520	351	3	1820	1430	313	3	1590	1340	273	2
FW 06 FWFV	4500	3320	772	13	3890	3080	668	10	3200	2810	550	7	2640	2640	453	5
	3660	2670	628	9	3150	2460	540	7	2550	2220	435	5	2120	2120	365	3
	2990	2120	513	6	2530	1940	435	5	2040	1740	350	3	1770	1640	303	3
FW 08 FWFV	6390	4540	1097	11	5530	4180	949	9	4530	3780	778	6	3680	3680	633	4
	5020	3550	862	7	4290	3240	735	6	3330	2860	571	4	2840	2680	487	3
	3740	2620	642	4	3210	2390	551	3	2860	2250	490	3	2490	2110	427	2
FW 10 TWTV	7590	5460	1301	15	6570	5050	1128	12	5430	4610	932	8	4430	4430	761	6
	5930	4260	1016	10	5090	3930	873	7	4090	3540	702	5	3420	3420	587	4
	3880	2800	665	5	3260	2550	559	3	2890	2410	496	3	2510	2260	431	2

4TW60012-1A (Sheet 4/13)

5 Capacity tables

5 - 2 Cooling capacity tables - 4-pipe

1
5

Air temperature (°C DB - °C WB) Water temperature (Entering °C - leaving °C)		27 - 19						8 - 13						9 - 14									
		6 - 11			7 - 12			8 - 13			9 - 14			6 - 11			7 - 12			8 - 13			9 - 14
Model		Total cooling capacity W	Sensible cooling capacity W	Water flow ℓ/h	Water pressure drop kPa	Total cooling capacity W	Sensible cooling capacity W	Water flow ℓ/h	Water pressure drop kPa	Total cooling capacity W	Sensible cooling capacity W	Water flow ℓ/h	Water pressure drop kPa	Total cooling capacity W	Sensible cooling capacity W	Water flow ℓ/h	Water pressure drop kPa	Total cooling capacity W	Sensible cooling capacity W	Water flow ℓ/h	Water pressure drop kPa		
FW 01 FV/FV	Max.	1660	1220	285	15	1460	1140	250	12	1240	1060	213	9	1040	1040	178	7	1040	1040	178	7		
	Med.	1300	970	223	10	1140	900	196	8	970	840	166	6	810	810	139	4	810	810	139	4		
	Min.	1130	810	193	8	990	750	169	6	840	700	144	5	670	640	115	3	670	640	115	3		
FW 02 FV/FV	Max.	2140	1600	367	18	1900	1510	326	15	1650	1410	283	11	1300	1300	224	7	1300	1300	224	7		
	Med.	1820	1330	312	14	1620	1250	278	11	1400	1160	240	9	1160	1070	199	6	1160	1070	199	6		
	Min.	1510	1080	260	10	1350	1010	231	8	1170	940	200	6	960	860	165	4	960	860	165	4		
FW 03 FV/FV	Max.	3220	2210	552	13	2870	2070	493	11	2490	1910	427	8	2060	1750	354	6	2060	1750	354	6		
	Med.	2610	1780	449	9	2330	1660	400	8	2010	1530	345	6	1640	1390	282	4	1640	1390	282	4		
	Min.	1960	1340	336	6	1730	1240	297	5	1470	1130	253	3	1310	1070	225	3	1310	1070	225	3		
FW 04 FV/FV	Max.	4780	3310	821	15	4260	3090	730	12	3680	2870	632	9	3030	2620	520	7	3030	2620	520	7		
	Med.	3640	2590	625	9	3230	2420	554	7	2760	2230	474	6	2200	2010	377	4	2200	2010	377	4		
	Min.	2820	1920	483	6	2480	1780	425	5	2080	1620	357	3	1850	1530	317	3	1850	1530	317	3		
FW 06 FV/FV	Max.	5250	3800	900	17	4670	3570	802	14	4050	3320	696	11	3360	3060	577	8	3360	3060	577	8		
	Med.	4280	3060	735	12	3810	2870	653	10	3290	2660	564	7	2680	2430	461	5	2680	2430	461	5		
	Min.	3510	2440	603	8	3110	2280	534	7	2660	2100	457	5	2100	1880	361	3	2100	1880	361	3		
FW 08 FV/FV	Max.	7430	5190	1275	15	6640	4850	1138	12	5760	4500	990	9	4770	4120	819	7	4770	4120	819	7		
	Med.	5880	4080	1010	10	5230	3800	898	8	4500	3510	772	6	3600	3160	618	4	3600	3160	618	4		
	Min.	4470	3050	767	6	3930	2820	675	5	3270	2550	562	3	2900	2400	497	3	2900	2400	497	3		
FW 10 TV/TV	Max.	8840	6240	1516	20	7880	5850	1352	16	6840	5450	1173	12	5690	5020	977	9	5690	5020	977	9		
	Med.	6930	4890	1190	13	6160	4570	1057	10	5320	4240	912	8	4340	3880	745	6	4340	3880	745	6		
	Min.	4650	3260	797	6	4070	3020	699	5	3390	2750	581	4	2930	2580	503	3	2930	2580	503	3		

4TW60012-1A (Sheet 6/13)

5 Capacity tables

5 - 2 Cooling capacity tables - 4-pipe

Air temperature (°C DB - °C WB) Water temperature (Entering °C - leaving °C)		30 - 22						8 - 13						9 - 14									
		6 - 11			7 - 12			8 - 13			9 - 14			6 - 11			7 - 12			8 - 13			9 - 14
Model		Total cooling capacity W	Seoike cooling capacity W	Water flow ℓ/h	Water pressure drop kPa	Total cooling capacity W	Seoike cooling capacity W	Water flow ℓ/h	Water pressure drop kPa	Total cooling capacity W	Seoike cooling capacity W	Water flow ℓ/h	Water pressure drop kPa	Total cooling capacity W	Seoike cooling capacity W	Water flow ℓ/h	Water pressure drop kPa	Total cooling capacity W	Seoike cooling capacity W	Water flow ℓ/h	Water pressure drop kPa		
FW 01 FWFV	Max.	2510	1440	430	32	2320	1370	398	27	2120	1300	364	23	1910	1230	329	19						
	Med.	1970	1150	337	21	1820	1090	312	18	1670	1030	286	15	1500	980	258	13						
	Min.	1690	970	290	16	1570	920	269	14	1440	870	246	12	1300	820	223	10						
FW 02 FWFV	Max.	3150	1880	540	35	2920	1790	502	31	2690	1700	462	27	2450	1610	421	23						
	Med.	2660	1570	457	27	2480	1490	425	23	2280	1420	392	20	2080	1340	357	17						
	Min.	2210	1280	379	19	2060	1220	353	17	1900	1150	326	15	1730	1090	297	12						
FW 03 FWFV	Max.	4670	2630	802	26	4360	2500	748	23	4030	2370	692	20	3680	2230	632	17						
	Med.	3790	2130	650	18	3540	2020	607	16	3280	1910	562	14	2990	1800	514	12						
	Min.	2840	1600	487	11	2660	1520	456	10	2460	1440	422	8	2250	1350	387	7						
FW 04 FWFV	Max.	6990	3930	1199	29	6510	3740	1117	25	6010	3540	1032	22	5480	3340	941	18						
	Med.	5330	3080	915	18	4970	2930	853	16	4590	2770	789	14	4190	2610	720	12						
	Min.	4140	2320	710	11	3860	2200	663	10	3570	2080	613	9	3260	1950	560	7						
FW 06 FWFV	Max.	7650	4470	1312	33	7130	4260	1224	29	6580	4040	1130	25	6000	3820	1031	21						
	Med.	6250	3630	1073	23	5830	3450	1001	20	5380	3270	925	18	4920	3090	844	15						
	Min.	5130	2920	880	16	4790	2770	822	14	4430	2620	760	13	4040	2470	694	11						
FW 08 FWFV	Max.	10760	6140	1846	28	10050	5840	1724	25	9290	5530	1596	21	8500	5220	1460	18						
	Med.	8550	4860	1467	19	7990	4620	1371	17	7390	4370	1269	14	6760	4120	1161	12						
	Min.	6580	3680	1127	12	6140	3490	1054	10	5680	3300	975	9	5180	3100	891	8						
FW 10 TWTV	Max.	12880	7340	2208	38	12010	7000	2061	34	11090	6640	1904	29	10110	6280	1737	25						
	Med.	10140	5790	1740	25	9450	5510	1622	22	8730	5220	1498	19	7960	4930	1367	16						
	Min.	6900	3920	1183	13	6430	3720	1103	11	5930	3520	1018	10	5400	3310	927	8						

4TW60012-1A (Sheet 8/13)

5 Capacity tables

5 - 3 Capacity tables with glycol for process cooling applications

Cooling mode

Glycol percentage in weight	Freezing temperature (°C)	Capacity correction factor	Pressure drop correction factor
0	0	1	1.00
10	-4	0.93	1.09
20	-10	0.84	1.18
30	-16	0.76	1.27
40	-24	0.76	1.36

Heating mode

Glycol percentage in weight	Freezing temperature (°C)	Capacity correction factor	Pressure drop correction factor
0	0	1	1.00
10	-4	0.98	1.08
20	-10	0.97	1.11
30	-16	0.94	1.22
40	-24	0.91	1.33

4TW60228-1B

Correction factors are based on an average value (at rated water flow rate). This can cause deviation depending on conditions used. The Fan Coil Selection software will provide an accurate result at all conditions.

5 Capacity tables

5 - 4 Heating capacity tables - 2-pipe

Air temperature (°C) Water temperature (Entering °C - leaving °C)		20															
		45 - 40				60 - 50				70 - 60				90 - 70			
		Heating capacity W	Water flow ℓ/h	Water pressure drop kPa	Water pressure drop	Heating capacity W	Water flow ℓ/h	Water pressure drop kPa	Water pressure drop	Heating capacity W	Water flow ℓ/h	Water pressure drop kPa	Water pressure drop	Heating capacity W	Water flow ℓ/h	Water pressure drop kPa	Water pressure drop
FW 01 TW/TV	Max.	1820	317	15	2840	249	10	3710	325	15	4940	218	7				
	Med.	1480	256	11	2310	201	7	2990	263	10	4010	177	5				
	Min.	1210	211	8	1900	166	5	2470	216	7	3320	147	3				
FW 02 TW/TV	Max.	2150	373	12	3360	293	7	4350	382	11	5830	257	5				
	Med.	1810	315	9	2840	248	6	3670	322	8	4940	218	4				
	Min.	1500	260	6	2350	206	4	3040	267	6	4110	181	3				
FW 03 TW/TV	Max.	3200	556	11	5030	439	7	6460	567	11	8760	386	5				
	Med.	2580	449	8	4070	356	5	5220	458	7	7110	314	4				
	Min.	1910	332	5	3020	264	3	3860	339	4	5290	233	2				
FW 04 TW/TV	Max.	4730	823	12	7420	648	8	9570	840	12	12890	569	6				
	Med.	3610	628	8	5690	497	5	7300	641	7	9910	437	4				
	Min.	2760	480	5	4360	381	3	5590	490	5	7620	336	2				
FW 06 TW/TV	Max.	5360	932	15	8410	735	9	10850	952	14	14620	645	7				
	Med.	4390	763	11	6900	603	7	8860	778	10	12020	530	5				
	Min.	3570	620	7	5630	491	5	7200	632	7	9810	433	3				
FW 08 TW/TV	Max.	6490	1129	10	10170	889	6	13130	1152	9	17650	779	4				
	Med.	5170	898	7	8100	708	4	10460	918	6	14100	623	3				
	Min.	3970	690	4	6230	544	3	8060	707	4	10880	480	2				
FW 10 TW/TV	Max.	8400	1460	19	13130	1147	12	17000	1492	18	22760	1005	8				
	Med.	6530	1135	12	10220	893	7	13200	1158	11	17740	783	5				
	Min.	4390	764	6	6890	602	4	8910	782	6	12020	531	3				

4TW60012-1A (Sheet 9/13)

5 Capacity tables

5 - 4 Heating capacity tables - 2-pipe

1
5

Air temperature (°C) Water temperature (Entering °C - leaving °C)		22							
		45 - 40		60 - 50		70 - 60		90 - 70	
Model	Heating capacity W	Water flow ℓ/h	Water pressure drop kPa	Heating capacity W	Water flow ℓ/h	Water pressure drop kPa	Heating capacity W	Water flow ℓ/h	Water pressure drop kPa
FW 01 TIV	Max.	287	13	2670	233	9	3530	310	13
	Med.	232	9	2160	189	6	2850	250	9
	Min.	191	6	1780	156	4	2350	206	7
FW 02 TIV	Max.	338	10	3150	275	7	4140	363	10
	Med.	285	7	2660	233	5	3500	307	8
	Min.	236	5	2210	193	4	2890	254	6
FW 03 TIV	Max.	505	10	4730	413	6	6150	540	10
	Med.	407	7	3820	334	4	4970	436	7
	Min.	302	4	2840	248	3	3670	322	4
FW 04 TIV	Max.	746	10	6970	609	7	9110	799	11
	Med.	570	6	5340	466	4	6960	610	7
	Min.	436	4	4090	357	3	5320	467	4
FW 06 TIV	Max.	846	13	7900	690	8	10330	906	13
	Med.	683	9	6490	567	6	8440	740	9
	Min.	562	6	5280	461	4	6850	601	6
FW 08 TIV	Max.	1024	8	9550	834	5	12500	1097	9
	Med.	813	6	7600	664	4	9960	874	6
	Min.	625	3	5840	510	2	7670	673	4
FW 10 TIV	Max.	1323	16	12320	1077	10	16190	1420	16
	Med.	1029	10	9600	839	7	12570	1102	10
	Min.	692	5	6460	565	3	8490	744	5

4TW60012-1A (Sheet 10/13)

5 Capacity tables

5 - 5 Heating capacity tables - 4-pipe

Air temperature (°C)		20								
		45 - 40		60 - 50		70 - 60		90 - 70		
Water temperature (Entering °C - leaving °C)	Model	Heating capacity W	Water flow ℓ/h	Water pressure drop kPa	Heating capacity W	Water flow ℓ/h	Water pressure drop kPa	Heating capacity W	Water flow ℓ/h	Water pressure drop kPa
FW 01 FWFV	Max.	920	161	6	1420	124	3	1900	167	6
	Med.	820	143	5	1270	111	3	1700	149	5
	Min.	720	126	4	1110	97	2	1500	132	4
FW 02 FWFV	Max.	980	170	8	1500	131	5	2010	176	7
	Med.	860	150	6	1330	116	4	1780	156	6
	Min.	750	131	5	1160	101	3	1560	137	5
FW 03 FWFV	Max.	1470	255	5	2240	196	3	3080	270	5
	Med.	1260	220	4	1930	169	2	2680	235	4
	Min.	1030	179	3	1570	137	2	2180	191	3
FW 04 FWFV	Max.	2460	427	13	3790	331	8	5050	443	12
	Med.	2070	360	9	3200	280	6	4250	373	9
	Min.	1750	304	7	2710	237	4	3600	316	7
FW 06 FWFV	Max.	2580	448	10	3970	347	6	5300	465	10
	Med.	2260	393	8	3490	305	5	4650	408	8
	Min.	1970	343	6	3050	266	4	4040	355	6
FW 08 FWFV	Max.	3890	675	31	6020	526	19	7910	694	30
	Med.	3360	584	24	5210	456	15	6830	600	23
	Min.	2800	486	18	4350	380	11	5690	499	17
FW 10 TWTV	Max.	4560	793	37	7060	617	23	9300	816	36
	Med.	3910	679	28	6050	529	17	7950	698	27
	Min.	3010	523	18	4680	409	11	6120	537	17

4TW60012-1A (Sheet 11/13)

5 Capacity tables

5 - 5 Heating capacity tables - 4-pipe

1
5

Air temperature (°C) Water temperature (Entering °C - leaving °C)		45 - 40			60 - 50			70 - 60			90 - 70		
		Heating capacity W	Water flow ℓ/h	Water pressure drop kPa	Heating capacity W	Water flow ℓ/h	Water pressure drop kPa	Heating capacity W	Water flow ℓ/h	Water pressure drop kPa	Heating capacity W	Water flow ℓ/h	Water pressure drop kPa
FW 01 FWFV	Max.	830	144	5	1320	115	3	1810	159	5	2370	105	2
	Med.	740	128	4	1180	103	2	1620	142	4	2130	94	2
	Min.	650	113	3	1040	91	2	1430	125	3	1870	83	2
FW 02 FWFV	Max.	870	152	6	1400	122	4	1910	167	7	2500	110	3
	Med.	770	134	5	1230	108	3	1690	148	6	2220	98	3
	Min.	670	117	4	1080	94	3	1480	130	4	1940	86	2
FW 03 FWFV	Max.	1300	227	4	2080	181	3	2930	257	5	3790	167	2
	Med.	1120	195	3	1790	156	2	2530	222	4	3270	144	2
	Min.	910	158	2	1450	127	1	2060	181	3	2660	118	1
FW 04 FWFV	Max.	2210	385	11	3540	310	7	4800	421	11	6320	279	5
	Med.	1860	324	8	2990	261	5	4040	354	8	5340	236	4
	Min.	1570	273	6	2520	220	4	3420	300	6	4550	201	3
FW 06 FWFV	Max.	2320	403	9	3710	324	6	5040	442	9	6630	292	4
	Med.	2040	354	7	3260	285	4	4420	387	7	5830	257	3
	Min.	1770	308	5	2840	248	3	3840	337	6	5090	225	3
FW 08 FWFV	Max.	3510	610	26	5640	493	17	7530	660	27	10020	443	13
	Med.	3040	528	20	4890	427	13	6500	570	21	8680	383	10
	Min.	2530	440	15	4080	356	10	5410	475	15	7260	320	7
FW 10 TWV	Max.	4120	717	31	6610	578	20	8850	777	33	11750	519	16
	Med.	3530	614	24	5670	495	16	7570	664	25	10080	445	12
	Min.	2720	473	15	4380	383	10	5820	511	16	7800	344	8

4TW60012-1A (Sheet 12/13)

5 Capacity tables

5 - 6 Power consumption - 2-pipe

FW.01	Max.		Med.		Min.	
	Power input	Current	Power input	Current	Power input	Current
ESP	(W)	(A)	(W)	(A)	(W)	(A)
(Pa)	(W)	(A)	(W)	(A)	(W)	(A)
0	37	0,170	28	0,130	21	0,100
10	37	0,160	26	0,120	21	0,090
20	35	0,150	25	0,110	20	0,088
30	35	0,150	24	0,110		
45	34	0,140				
50	33	0,140				

4TW60011-2A (2/15)

FW.02	Max.		Med.		Min.	
	Power input	Current	Power input	Current	Power input	Current
ESP	(W)	(A)	(W)	(A)	(W)	(A)
(Pa)	(W)	(A)	(W)	(A)	(W)	(A)
0	53	0,240	36	0,160	24	0,110
10	52	0,235	32	0,142	21	0,096
20	48	0,217	31	0,138	21	0,096
30	46	0,208	31	0,138	20	0,092
40	46	0,208	30	0,133		

4TW60011-2A (3/15)

FW.03	Max.		Med.		Min.	
	Power input	Current	Power input	Current	Power input	Current
ESP	(W)	(A)	(W)	(A)	(W)	(A)
(Pa)	(W)	(A)	(W)	(A)	(W)	(A)
0	56	0,252	43	0,200	29	0,138
10	55	0,248	42	0,195	29	0,134
20	53	0,239	41	0,191	29	0,131
30	53	0,239	41	0,191	28	0,130
40	52	0,234	40	0,186		
50	51	0,230				

4TW60011-2A (4/15)

FW.04	Max.		Med.		Min.	
	Power input	Current	Power input	Current	Power input	Current
ESP	(W)	(A)	(W)	(A)	(W)	(A)
(Pa)	(W)	(A)	(W)	(A)	(W)	(A)
0	98	0,440	61	0,287	38	0,192
10	94	0,422	59	0,276	37	0,187
20	92	0,413	57	0,259	36	0,182
30	90	0,404	55	0,254	34	0,172
40	88	0,395	53	0,242	31	0,157
50	85	0,382	50	0,228		
60	81	0,364	45	0,211		
70	76	0,341				
75	74	0,332				

4TW60011-2A (5/15)

SYMBOLS

ESP: External static pressure

5 Capacity tables

5 - 6 Power consumption - 2-pipe

1

5

FW.06	Max.		Med.		Min.	
	Power input	Current	Power input	Current	Power input	Current
ESP	(W)	(A)	(W)	(A)	(W)	(A)
(Pa)	(W)	(A)	(W)	(A)	(W)	(A)
0	98	0.430	68	0.310	47	0.220
10	96	0.421	67	0.305	45	0.211
20	94	0.412	64	0.292	44	0.206
30	91	0.399	62	0.283	43	0.201
40	90	0.395	61	0.278	42	0.197
50	89	0.391	59	0.269		
60	86	0.377	56	0.255		
70	82	0.360				

4TW60011-2A (6/15)

FW.08	Max.		Med.		Min.	
	Power input	Current	Power input	Current	Power input	Current
ESP	(W)	(A)	(W)	(A)	(W)	(A)
(Pa)	(W)	(A)	(W)	(A)	(W)	(A)
0	182	0.802	127	0.574	86	0.393
10	178	0.780	124	0.560	83	0.385
20	174	0.761	121	0.547	82	0.377
30	169	0.741	118	0.532	81	0.371
40	166	0.721	116	0.522	80	0.363
50	161	0.698	114	0.509	78	0.354
60	157	0.680	111	0.497	76	0.343
70	153	0.662	108	0.482		
80	147	0.639	104	0.464		
90	142	0.620	101	0.453		
100	137	0.595				

4TW60011-2A (7/15)

FW.10	Max.		Med.		Min.	
	Power input	Current	Power input	Current	Power input	Current
ESP	(W)	(A)	(W)	(A)	(W)	(A)
(Pa)	(W)	(A)	(W)	(A)	(W)	(A)
0	244	1.065	169	0.780	109	0.543
10	240	1.048	165	0.753	108	0.528
20	232	1.010	160	0.735	106	0.513
30	222	0.985	155	0.711	105	0.500
40	214	0.960	151	0.690	104	0.495
50	207	0.925	147	0.673	102	0.485
60	199	0.900	143	0.656	96	0.453
70	192	0.872	139	0.636		
80	188	0.847	135	0.615		
90	183	0.820	129	0.591		
100	176	0.799				

4TW60011-2A (8/15)

SYMBOLS

ESP: External static pressure

5 Capacity tables

5 - 7 Power consumption - 4-pipe

FW.01	Max.		Med.		Min.	
	Power input	Current	Power input	Current	Power input	Current
ESP	(W)	(A)	(W)	(A)	(W)	(A)
(Pa)	(W)	(A)	(W)	(A)	(W)	(A)
0	37	0.170	28	0.130	21	0.100
10	37	0.160	26	0.120	21	0.090
20	35	0.150	25	0.110	20	0.088
30	35	0.150	24	0.110		
45	34	0.140				
50	33	0.140				

4TW60011-2A (9/15)

FW.02	Max.		Med.		Min.	
	Power input	Current	Power input	Current	Power input	Current
ESP	(W)	(A)	(W)	(A)	(W)	(A)
(Pa)	(W)	(A)	(W)	(A)	(W)	(A)
0	53	0.240	36	0.160	24	0.110
10	52	0.235	32	0.142	21	0.096
20	48	0.217	31	0.138	21	0.096
30	46	0.208	31	0.138	20	0.092
40	46	0.208	30	0.133		

4TW60011-2A (10/15)

FW.03	Max.		Med.		Min.	
	Power input	Current	Power input	Current	Power input	Current
ESP	(W)	(A)	(W)	(A)	(W)	(A)
(Pa)	(W)	(A)	(W)	(A)	(W)	(A)
0	56	0.252	43	0.200	29	0.138
10	55	0.248	42	0.195	29	0.134
20	53	0.239	41	0.191	29	0.131
30	53	0.239	41	0.191	28	0.130
40	52	0.234	40	0.186		
50	51	0.230				

4TW60011-2A (11/15)

FW.04	Max.		Med.		Min.	
	Power input	Current	Power input	Current	Power input	Current
ESP	(W)	(A)	(W)	(A)	(W)	(A)
(Pa)	(W)	(A)	(W)	(A)	(W)	(A)
0	98	0.440	61	0.287	38	0.192
10	94	0.422	59	0.276	37	0.187
20	92	0.413	57	0.259	36	0.182
30	90	0.404	55	0.254	34	0.172
40	88	0.395	53	0.242	31	0.157
50	85	0.382	50	0.228		
60	81	0.364	45	0.211		
70	76	0.341				
75	74	0.332				

4TW60011-2A (12/15)

SYMBOLS

ESP: External static pressure

5 Capacity tables

5 - 7 Power consumption - 4-pipe

1

5

FW.06	Max.		Med.		Min.	
	Power input	Current	Power input	Current	Power input	Current
ESP	(W)	(A)	(W)	(A)	(W)	(A)
(Pa)	(W)	(A)	(W)	(A)	(W)	(A)
0	98	0.430	68	0.310	47	0.220
10	96	0.421	67	0.305	45	0.211
20	94	0.412	64	0.292	44	0.206
30	91	0.399	62	0.283	43	0.201
40	90	0.395	61	0.278	42	0.197
50	89	0.391	59	0.269		
60	86	0.377	56	0.255		
70	82	0.360				

4TW60011-2A (13/15)

FW.08	Max.		Med.		Min.	
	Power input	Current	Power input	Current	Power input	Current
ESP	(W)	(A)	(W)	(A)	(W)	(A)
(Pa)	(W)	(A)	(W)	(A)	(W)	(A)
0	182	0.802	127	0.574	86	0.393
10	178	0.780	124	0.560	83	0.385
20	174	0.761	121	0.547	82	0.377
30	169	0.741	118	0.532	81	0.371
40	166	0.721	116	0.522	80	0.363
50	161	0.698	114	0.509	78	0.354
60	157	0.680	111	0.497	76	0.343
70	153	0.662	108	0.482		
80	147	0.639	104	0.464		
90	142	0.620	101	0.453		
100	137	0.595				

4TW60011-2A (14/15)

FW.10	Max.		Med.		Min.	
	Power input	Current	Power input	Current	Power input	Current
ESP	(W)	(A)	(W)	(A)	(W)	(A)
(Pa)	(W)	(A)	(W)	(A)	(W)	(A)
0	244	1.065	169	0.780	109	0.543
10	240	1.048	165	0.753	108	0.528
20	232	1.010	160	0.735	106	0.513
30	222	0.985	155	0.711	105	0.500
40	214	0.960	151	0.690	104	0.495
50	207	0.925	147	0.673	102	0.485
60	199	0.900	143	0.656	96	0.453
70	192	0.872	139	0.636		
80	188	0.847	135	0.615		
90	183	0.820	129	0.591		
100	176	0.799				

4TW60011-2A (15/15)

SYMBOLS

ESP: External static pressure

5 Capacity tables

5 - 8 Capacity correction factor

FWV - FWL - FWM	ESP	10		20		30		40		50		60	
		F1	F2	F1	F2	F1	F2	F1	F2	F1	F2	F1	F2
FW.01	Fan speed	0.86	0.91	0.72	0.8	0.56	0.67	-	-	-	-	-	-
	Max.	0.78	0.84	0.56	0.65	0.33	0.41	-	-	-	-	-	-
	Med.	0.71	0.77	0.35	0.4	-	-	-	-	-	-	-	-
FW.02	Max.	0.85	0.89	0.73	0.78	0.61	0.67	0.5	0.57	0.4	0.47	0.31	0.36
	Med.	0.82	0.85	0.63	0.68	0.45	0.5	0.27	0.3	-	-	-	-
	Min.	0.78	0.8	0.55	0.59	0.35	0.37	-	-	-	-	-	-
FW.03	Max.	0.89	0.91	0.77	0.81	0.64	0.69	0.51	0.56	0.36	0.4	0.18	0.21
	Med.	0.82	0.84	0.64	0.67	0.47	0.5	0.29	0.32	-	-	-	-
	Min.	0.75	0.77	0.48	0.5	-	-	-	-	-	-	-	-
FW.04	Max.	0.93	0.95	0.85	0.89	0.77	0.82	0.67	0.73	0.56	0.63	0.42	0.5
	Med.	0.91	0.93	0.81	0.84	0.71	0.75	0.59	0.64	0.46	0.51	0.31	0.35
	Min.	0.84	0.86	0.68	0.71	0.52	0.55	0.34	0.36	-	-	-	-
FW.06	Max.	0.93	0.95	0.85	0.89	0.77	0.81	0.67	0.73	0.56	0.62	0.41	0.47
	Med.	0.92	0.93	0.82	0.86	0.73	0.77	0.61	0.66	0.48	0.53	0.31	0.36
	Min.	0.86	0.88	0.71	0.74	0.56	0.59	0.4	0.43	0.23	0.25	-	-
FW.08	Max.	0.96	0.96	0.91	0.92	0.86	0.88	0.8	0.83	0.74	0.78	0.67	0.71
	Med.	0.95	0.96	0.9	0.92	0.85	0.87	0.79	0.81	0.73	0.76	0.65	0.69
	Min.	0.91	0.92	0.81	0.82	0.71	0.73	0.6	0.62	0.49	0.51	0.37	0.39
FW.10	Max.	0.96	0.97	0.92	0.93	0.87	0.89	0.82	0.85	0.77	0.81	0.72	0.76
	Med.	0.95	0.96	0.9	0.91	0.84	0.86	0.78	0.81	0.71	0.75	0.64	0.68
	Min.	0.92	0.93	0.84	0.86	0.76	0.78	0.67	0.69	0.57	0.6	0.47	0.5

	FW.01		FW.02		FW.03		FW.04		FW.06		FW.08		FW.10	
	medium	low	medium	low	medium	low	medium	low	medium	low	medium	low	medium	low
Total cooling capacity	TCC	0.81	0.68	0.87	0.69	0.81	0.60	0.76	0.58	0.81	0.66	0.79	0.59	0.52
Sensible cooling capacity	SCC	0.81	0.66	0.87	0.70	0.81	0.60	0.78	0.57	0.80	0.64	0.78	0.58	0.51
Heating capacity - 2 pipe	HC2P	0.81	0.66	0.83	0.68	0.81	0.59	0.76	0.58	0.66	0.66	0.79	0.61	0.52
Heating capacity - 4 pipe	HC40	0.85	0.73	0.89	0.78	0.87	0.71	0.83	0.69	0.88	0.76	0.86	0.72	0.66

4TW60018-1

Conditions
 Cooling Air: 27°C DB - 19°C WB - Water: entering 7°C - leaving 12°C
 Heating 2-pipe Air: 20°C Water: entering 50°C water flow as for cooling
 Heating 4-pipe Air: 20°C Water: entering 70°C - leaving 60°C

F1 = correction factor for air flow
 F2 = correction factor for capacities

Correction factors are based on an average value. This can cause deviation depending on conditions used. The Fan Coil Selection software will provide an accurate result at all conditions.

6 Dimensional drawing & centre of gravity

6 - 1 Dimensional drawing

FWV - FWL

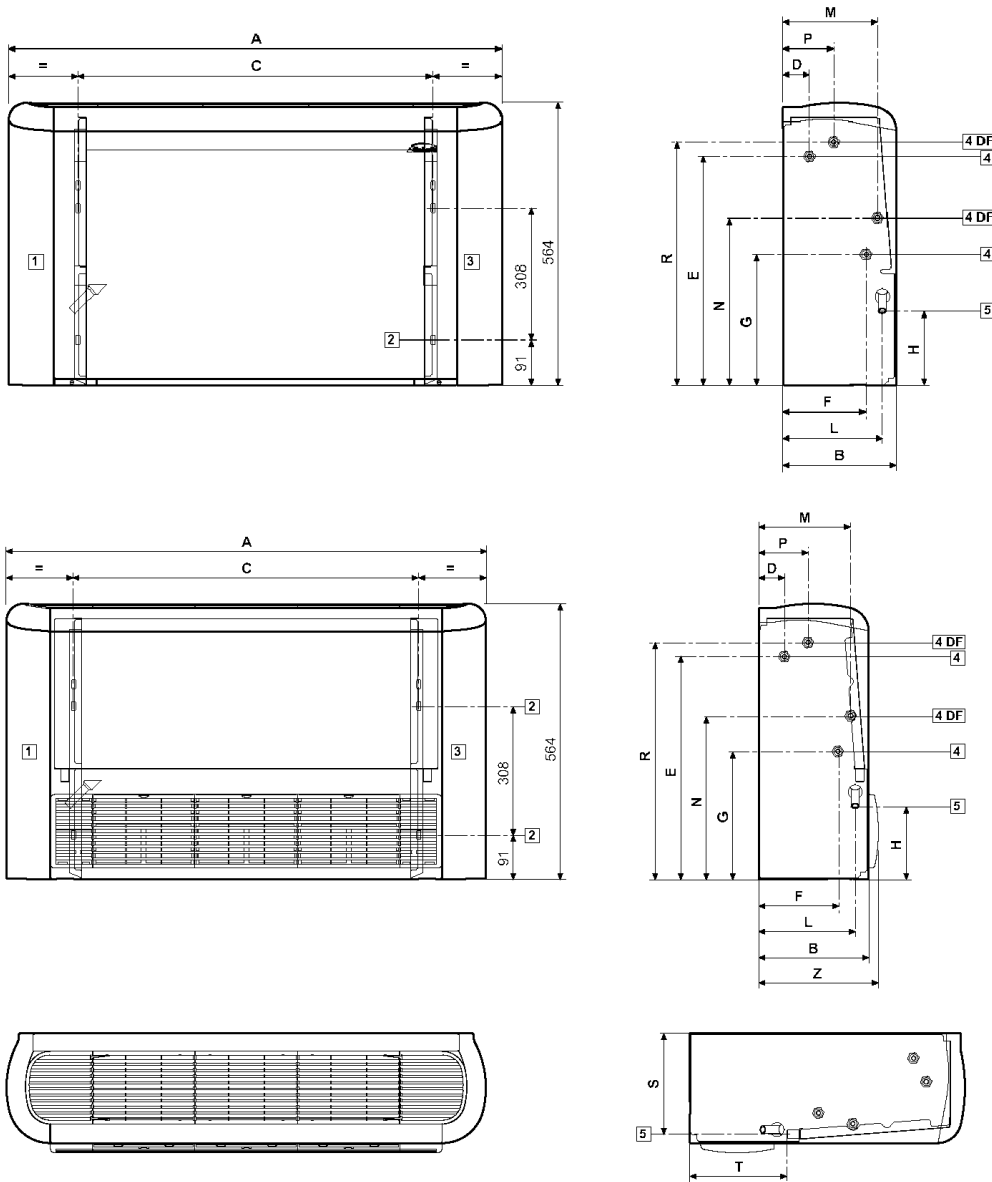

	A	B	C	D	E	F	G	H	L	M	N	P	R	S	T	Z
FWV+FWL 01+02	774	226	498	51	458	163	263	149	198	187	335	99	486	208	198	246
FWV+FWL 03	984	226	708	51	458	163	263	149	198	187	335	99	486	208	198	246
FWV+FWL 04+06	1194	226	918	51	458	163	263	149	198	187	335	99	486	208	198	246
FWV+FWL 08+10	1404	251	1128	48	497	185	259	155	220	195	348	120	478	234	208	271

Legend

- 1 Clear space for hydraulic connections (*)
- 2 Slots for wall / ceiling mounting 9x20mm
- 3 Clear space for electric connections (*)
- 4 Hydraulic connections (4DF = 4 pipe system)
- 5 Condensate drainage for vertical installation
- 6 Air outlet for concealed models
- 7 Air suction for concealed models
- 8 Condensate drainage for horizontal installation
- 9 Air outlet
- 10 Air inlet

Hydraulic connections

Standard heat exchanger: connection female

FW01	FW02	FW03	FW04	FW06	FW08	FW10
1/2"	1/2"	1/2"	1/2"	1/2"	3/4"	3/4"

Additional heat exchanger: connection female

FW01	FW02	FW03	FW04	FW06	FW08	FW10
1/2"	1/2"	1/2"	1/2"	1/2"	1/2"	1/2"

(*) Indications applicable to fan coils with hydraulic connections on the left side; in case of right side connections the indications for "clear space" are reversed.

6 Dimensional drawing & centre of gravity

6 - 1 Dimensional drawing

FWM

The drawing shows three views of the FWM fan coil unit: a top view, a front view, and a side view. Dimensions are labeled with letters A through W. Callouts 1 through 9 indicate specific features: 1 (clear space for hydraulic connections), 2 (slots for wall/ceiling mounting), 3 (clear space for electric connections), 4 (hydraulic connections), 5 (condensate drainage), 6 (air outlet for concealed models), 7 (air suction for concealed models), 8 (condensate drainage for horizontal installation), and 9 (air inlet). Specific dimensions include 20, 25, 91, 308, 535, 113, and 9.

	A	B	C	D	E	F	G	H	L	M	N	P	Q	R	S	T	U	V	W
FWM 01+02	584	224	498	51	458	163	263	149	198	187	335	99	189	486	208	198	436	464	61
FWM 03	794	224	708	51	458	163	263	149	198	187	335	99	189	486	208	198	646	674	61
FWM 04+06	1004	224	918	51	458	163	263	149	198	187	335	99	189	486	208	198	856	884	61
FWM 08+10	1214	249	1128	48	497	185	259	155	220	195	348	120	215	478	234	208	1066	1094	67

Required installation space

Keep at least 100 mm of free space at air inlet for a proper air suction and an easy removal of the filter.
For ducted units the outlet/inlet grill surface must be at least equal to the outlet/inlet surface of the unit to avoid extra noise and strong performance reduction.

Legend

- Clear space for hydraulic connections (*)
- Slots for wall / ceiling mounting 9x20mm
- Clear space for electric connections (*)
- Hydraulic connections (4DF = 4 pipe system)
- Condensate drainage for vertical installation
- Air outlet for concealed models
- Air suction for concealed models
- Condensate drainage for horizontal installation
- Air outlet
- Air inlet

Hydraulic connections

Standard heat exchanger: connection female

FW01	FW02	FW03	FW04	FW06	FW08	FW10
1/2"	1/2"	1/2"	1/2"	1/2"	3/4"	3/4"

Additional heat exchanger: connection female

FW01	FW02	FW03	FW04	FW06	FW08	FW10
1/2"	1/2"	1/2"	1/2"	1/2"	1/2"	1/2"

(*) Indications applicable to fan coils with hydraulic connections on the left side; in case of right side connections the indications for "clear space" are reversed.

4TW60014-1A (Sheet 2/2)

7 Wiring diagram

7 - 1 Wiring diagram

1
7

SYMBOLS

- BK Black = maximum speed
- BU Blue = medium speed
- GNYE Yellow/Green = earth connection
- RD Red = minimum speed
- WH White = common
- Field wiring
- F Protection fuse (field supply)
- IL Main switch (field supply)
- M Fan motor
- PE Earth connection

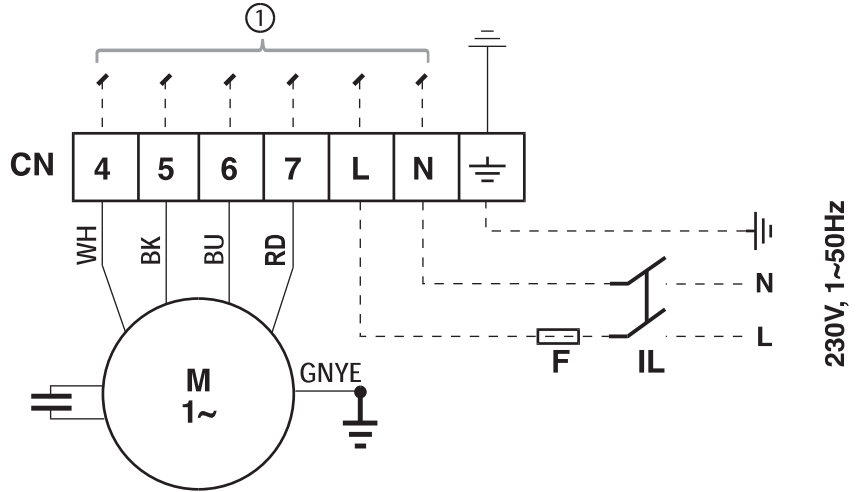

4TW60016-1

8 Sound data

8 - 1 Sound level data

Sound power level and Spectrum								
FW01 TN/TV								
Sound Power Levels dB(A)	125 Hz	250 Hz	500 Hz	1000 Hz	2000 Hz	4000 Hz	8000 Hz	Global Lw
Max.	24.8	39.1	41.7	38.4	33.7	21.6	15.6	45
Med.	19.4	34.1	35.9	30.3	24.3	15.8	15.4	39
Min.	13.6	29.7	29.0	22.0	16.2	15.2	15.2	33
FW02 TN/TV								
Sound Power Levels dB(A)	125 Hz	250 Hz	500 Hz	1000 Hz	2000 Hz	4000 Hz	8000 Hz	Global Lw
Max.	28.8	42.7	45.8	43.6	39.3	29.9	17.2	50
Med.	22.9	37.8	40.7	36.2	30.3	19.6	15.4	44
Min.	18.0	33.1	35.4	29.1	22.7	15.5	15.3	38
FW03 TN/TV								
Sound Power Levels dB(A)	125 Hz	250 Hz	500 Hz	1000 Hz	2000 Hz	4000 Hz	8000 Hz	Global Lw
Max.	27.8	40.9	43.5	40.4	34.0	23.4	18.0	47
Med.	23.0	36.0	37.9	33.0	25.7	18.4	16.6	41
Min.	15.6	28.8	28.8	22.0	17.2	16.0	15.6	33
FW04 TN/TV								
Sound Power Levels dB(A)	125 Hz	250 Hz	500 Hz	1000 Hz	2000 Hz	4000 Hz	8000 Hz	Global Lw
Max.	31.7	45.4	47.7	45.4	41.7	32.0	19.2	52
Med.	23.6	37.6	39.8	34.2	28.7	21.6	16.5	43
Min.	17.8	31.8	31.5	24.4	17.2	16.5	15.4	35
FW06 TN/TV								
Sound Power Levels dB(A)	125 Hz	250 Hz	500 Hz	1000 Hz	2000 Hz	4000 Hz	8000 Hz	Global Lw
Max.	36.1	49.3	51.4	50.6	47.4	39.1	24.7	56
Med.	28.9	43.0	45.2	42.3	38.1	28.1	17.9	49
Min.	23.7	37.4	39.8	34.4	28.6	21.9	16.8	43
FW08 TN/TV								
Sound Power Levels dB(A)	125 Hz	250 Hz	500 Hz	1000 Hz	2000 Hz	4000 Hz	8000 Hz	Global Lw
Max.	40.0	54.2	55.8	54.7	52.8	46.4	35.2	61
Med.	33.6	47.9	49.2	47.7	45.0	36.3	23.9	54
Min.	27.7	41.7	42.1	40.3	35.5	25.8	21.1	47
FW10 TN/TV								
Sound Power Levels dB(A)	125 Hz	250 Hz	500 Hz	1000 Hz	2000 Hz	4000 Hz	8000 Hz	Global Lw
Max.	44.5	58.0	60.1	60.4	58.4	53.6	46.3	66
Med.	38.5	51.7	54.8	53.5	51.5	45.3	34.7	59
Min.	28.8	43.2	44.8	42.6	39.1	29.6	21.9	49
Conditions of measurements	in case of (M) models the sound power is calculated WITHOUT any additional inlet or outlet grill or plenum!							

4TW60017-1A (Sheet 1/2)

To calculate the sound pressure you must define some conditions and use this formula

$$L_p = L_w - 10 \times \log_{10} \left(\frac{4\pi \times d^2}{Q} \right)$$

Where:

Q = direction factor: is Q=4 if the FCU is installed near 2 walls (vertical or floor-ceiling), Q=2 if the FCU is installed near 1 wall (at floor or ceiling but faraway the 2nd wall)

d = distance (mt) from the sound source and the measure point

LP = Sound pressure (dBA)

Lw = Sound power (dBA)

8 Sound data

8 - 1 Sound level data

1
8

Sound power level and Spectrum								
FW01 FN/TV								
Sound Power Levels dB(A)	125 Hz	250 Hz	500 Hz	1000 Hz	2000 Hz	4000 Hz	8000 Hz	Global Lw
Max.	24.8	39.1	41.7	38.4	33.7	21.6	15.6	45
Med.	19.4	34.1	35.9	30.3	24.3	15.8	15.4	39
Min.	13.6	29.7	29.0	22.0	16.2	15.2	15.2	33
FW02 FN/TV								
Sound Power Levels dB(A)	125 Hz	250 Hz	500 Hz	1000 Hz	2000 Hz	4000 Hz	8000 Hz	Global Lw
Max.	28.8	42.7	45.8	43.6	39.3	29.9	17.2	50
Med.	22.9	37.8	40.7	36.2	30.3	19.6	15.4	44
Min.	18.0	33.1	35.4	29.1	22.7	15.5	15.3	38
FW03 FN/TV								
Sound Power Levels dB(A)	125 Hz	250 Hz	500 Hz	1000 Hz	2000 Hz	4000 Hz	8000 Hz	Global Lw
Max.	27.8	40.9	43.5	40.4	34.0	23.4	18.0	47
Med.	23.0	36.0	37.9	33.0	25.7	18.4	16.6	41
Min.	15.6	28.8	28.8	22.0	17.2	16.0	15.6	33
FW04 FN/TV								
Sound Power Levels dB(A)	125 Hz	250 Hz	500 Hz	1000 Hz	2000 Hz	4000 Hz	8000 Hz	Global Lw
Max.	31.7	45.4	47.7	45.4	41.7	32.0	19.2	52
Med.	23.6	37.6	39.8	34.2	28.7	21.6	16.5	43
Min.	17.8	31.8	31.5	24.4	17.2	16.5	15.4	35
FW06 FN/TV								
Sound Power Levels dB(A)	125 Hz	250 Hz	500 Hz	1000 Hz	2000 Hz	4000 Hz	8000 Hz	Global Lw
Max.	36.1	49.3	51.4	50.6	47.4	39.1	24.7	56
Med.	28.9	43.0	45.2	42.3	38.1	28.1	17.9	49
Min.	23.7	37.4	39.8	34.4	28.6	21.9	16.8	43
FW08 FN/TV								
Sound Power Levels dB(A)	125 Hz	250 Hz	500 Hz	1000 Hz	2000 Hz	4000 Hz	8000 Hz	Global Lw
Max.	39.0	53.2	54.8	53.7	51.8	45.4	34.2	60
Med.	33.6	47.9	49.2	47.7	45.0	36.3	23.9	54
Min.	26.7	40.7	41.1	39.3	34.5	24.8	20.1	46
FW10 FN/TV								
Sound Power Levels dB(A)	125 Hz	250 Hz	500 Hz	1000 Hz	2000 Hz	4000 Hz	8000 Hz	Global Lw
Max.	44.5	58.0	60.1	60.4	58.4	53.6	46.3	66
Med.	38.5	51.7	54.8	53.5	51.5	45.3	34.7	59
Min.	28.8	43.2	44.8	42.6	39.1	29.6	21.9	49
Conditions of measurements	in case of (M) models the sound power is calculated WITHOUT any additional inlet or outlet grill or plenum!							

4TW60017-1A (Sheet 2/2)

To calculate the sound pressure you must define some conditions and use this formula

$$L_p = L_w - 10 \times \log_{10} \left(\frac{4\pi \times d^2}{Q} \right)$$

Where:

Q = direction factor: is Q=4 if the FCU is installed near 2 walls (vertical or floor-ceiling), Q=2 if the FCU is installed near 1 wall (at floor or ceiling but faraway the 2nd wall)

d = distance (mt) from the sound source and the measure point

LP = Sound pressure (dBA)

Lw = Sound power (dBA)

9 Installation

9 - 1 Installation method

Fan coil units should be installed in a position where they heat and cool the room evenly, on walls or ceilings that can bear their weight. Fit any accessories on the standard unit before installing it. Read the relevant technical sheets for the installation and use of the accessories. Keep free space around the fan coil to allow proper operation and ordinary and extraordinary maintenance (see the "9. Dimensional drawings") Provide a panel to reach the unit in case of recessed mounting (Concealed models). Install the remote control panel, if any, in a position that can easily be reached by the user to set the functions and that is suitable for the proper detection of the temperature, if provided.

Therefore avoid:

- positions directly exposed to sunlight;
- positions exposed to hot or cold draughts;
- obstacles preventing the proper temperature detection

If the system is shut down during the winter months, drain off the water from the system to prevent damage due to freezing; if antifreeze solutions are used, check the freezing point using the table shown on technical manual.

Keep at least 100 mm of free space at air inlet for a proper air suction and an easy removal of the filter.

For ducted units the outlet/inlet grill surface must be at least equal to the outlet/inlet surface of the unit to avoid extra noise and strong performance reduction.

BEFORE THE INSTALLATION

Installation and maintenance should be carried out by technical personnel qualified for this type of machine, in compliance with current safety regulations.

For installation and use of possible accessories please refer to the pertinent technical sheets.

In choosing where to install the unit, comply with the following points:

- the heating unit should not be placed immediately under a socket
- do not install the unit in rooms where inflammable gases are present
- do not let water is sprayed directly on the unit
- install the unit on ceilings or walls that bear its weight. Leave enough space all around for proper operation and maintenance of the unit.

Keep the unit in its packaging until it is ready to be installed, to prevent dust getting inside it.

INSTALLATION WARNING:

On the fan coil install a switch (IL) and/or all remote controls in a position out of the reach of persons who are in a bathtub or shower.

In case of ceiling-mounted models, check that the installation height does not exceed the maximum height shown in 7. Dimensional drawings in order to avoid excessive hot air stratification in the upper part of the room; in case of greater installation heights we suggest to proceed with the back suction from the lower part of the room. The installation heights shown in the figure refer to the maximum running speed.

Carry out the hydraulic connections to the heat exchanger and in case of cooling operation, to the water drainage system. We suggest to provide for the water inlet from the bottom side of the heat exchanger and the outlet on the upper side. Bleed the air from the heat exchanger operating on the air-vent valves (10 hexagon wrench) located beside the water connections of the heat exchanger. For a better water drainage lean the drain pipe downwards at least 3 cm/m avoiding loops or narrowing on its way.

INSTALLATION FOR THE CONCEALED CEILING MODEL

The air outlets should not be placed immediately under a socket. For the concealed ceiling model, perform the connection between the fan coil and the ducts, and place damping material between the duct and the unit. The ducts, in particular the outlet ones, must be insulated. In order to avoid air back suction on the fan coil, keep a minimum distance between the air outlet and recovered air flow as shown in installation manual of the unit. The minimum installation height should not be lower than 1.8 metres from floor level. Provide for an inspection port to the unit.

9 Installation

9 - 1 Installation method

ELECTRICAL CONNECTIONS

Carry out the electrical wiring after having turned the power off in compliance with the relevant local and national regulations following the relevant wiring diagram.

Check that the power supply corresponds to the rated power reported on the unit nameplate.

Each fan coil requires a switch (IL) on the feeder line with a distance of at least 3 mm between the opening contacts, and a suitable safety fuse (F).

USE

To use the fan coil unit, refer to the instructions of the control panel, available as accessory.

Air outlet grids on the cover cabinet (wall mounted and floor/ceiling mounted) can be turned 180° to direct the flow into the room or towards the wall on which the unit is mounted. The grids and the side doors are snapped into the cabinet. Before removing them in order to change their position, cut the power off and wear protective gloves.

MAINTENANCE

For safety reasons before carrying out any maintenance or cleaning operation, switch off the unit turning the selection switch to "Stop" and the power supply switch on position 0 (OFF).

Be careful during any maintenance operation; you could get injured by some metal parts; use protective work gloves. The fan coils do not require any particular maintenance operation: only the periodical cleaning of the air filter should be carried out. It is necessary to carry out a running in period of 100 hours in order to eliminate all mechanical friction. The starting up must be carried out at the maximum speed.

For good operation of the fan coils follow the instructions below:

- keep the air filter clean;
- do not pour liquids into the unit;
- do not introduce metal parts through the air outlet grid;
- keep the air inlet and outlet free at all times.

Each time the machine is turned on after being idle for a long period, ensure there is no air in the heat exchanger. Before using the unit for air conditions, check that:

- condensate drainage is performed correctly;
- the heat exchanger fins are not obstructed by deposits of dirt.

If necessary clean the fins with low pressure compressed air or steam without damaging them.

CLEANING

For safety reasons before carrying out any maintenance or cleaning operation switch off the unit turning the selection switch to "Stop" and the power supply switch on 0 (OFF).

Clean the filter at least once a month and in any case before using the unit (before the heating or the air conditioning season).

For cleaning the air filter proceed as follows (pictures see manual of units):

- Floor models: turn the screws 90°, which secure the filter to the cover cabinet, to 1/4 turn and remove the filter;
- Concealed models: reach the fan coil through the inspection panel and remove the filter, turning the locking brackets 90°;
- Floor ceiling: remove the air filters that are inside the intake grids located on the front panel of the cover cabinet;
- clean the filter with lukewarm water, or in case of dry dust, with compressed air;
- reassemble the filter after having dried it up

It is recommended to replace the air filter yearly, and to use original spare parts; the fan coil model is reported on the nameplate located on the internal part of the side panel of the unit.

To clean the unit cabinet proceed as follows

- use a soft cloth;
- do not pour any liquid on the unit, as this could cause electrical shocks or damage the components inside it;
- do not use any aggressive chemical solvents; do not use very hot water to clean the air outlet grid

Note: this is only based text and should be combined with manuals for relative pictures and additional information.

10 Operation range

Minimum water temperature	+5°C
Maximum water temperature	+95°C
Maximum operating pressure	10 bar
Minimum air inlet temperature	5°C
Maximum air inlet temperature	+43°C
Power supply	230V +-10% / 1~ / 50Hz

4TW60013-1

1

10

11 Hydraulic performance

11 - 2 Water pressure drop curve evaporator heating 2-pipe

1
11

FWV / FWL / FWM							
Water flow l/h	Water pressure drop						
	FW..01	FW..02	FW..03	FW..04	FW..06	FW..08	FW..10
	kPa	kPa	kPa	kPa	kPa	kPa	kPa
50	0.71	0.41	0.19	0.11	0.1	0.05	0.05
100	2.44	1.42	0.66	0.36	0.35	0.16	0.20
200	8.25	4.81	2.25	1.23	1.21	0.56	0.67
300	16.84	9.81	4.6	2.51	2.46	1.14	1.37
400	27.92	16.27	7.63	4.17	4.09	1.9	2.29
500	41.33	24.09	11.3	6.18	6.06	2.82	3.39
600	56.93	33.19	15.57	8.51	8.35	3.89	4.68
800	94.32	55.02	25.82	14.12	13.84	6.44	7.75
1000	139.51	81.4	38.2	20.9	20.5	9.54	11.48
1500	-	165.77	77.83	42.61	41.8	19.46	23.42
2000	-	-	128.9	70.59	69.27	32.27	38.85
2500	-	-	-	104.41	102.47	47.75	57.50
3000	-	-	-	143.74	141.09	65.76	79.22
4000	-	-	-	-	-	108.92	131.28
5000	-	-	-	-	-	161.06	194.20

4TW60019-1A (Sheet 1/3)

11-2 Water pressure drop curve evaporator heating 2-pipe

FWV / FWL / FWM							
Water flow l/h	Water pressure drop						
	FW..01	FW..02	FW..03	FW..04	FW..06	FW..08	FW..10
	kPa	kPa	kPa	kPa	kPa	kPa	kPa
50	0.61	0.36	0.17	0.09	0.09	0.04	0.04
100	2.02	1.19	0.56	0.31	0.31	0.14	0.17
200	6.72	3.94	1.86	1.02	1.01	0.47	0.58
300	13.6	7.97	3.75	2.07	2.04	0.96	1.16
400	22.45	13.14	6.18	3.41	3.36	1.57	1.91
500	33.14	19.39	9.12	5.02	4.95	2.32	2.81
600	45.55	26.64	12.53	6.89	6.79	3.18	3.86
800	75.27	44.01	20.69	11.38	11.2	5.24	6.36
1000	111.15	64.97	30.54	16.79	16.52	7.72	9.37
1500	-	-	62.01	34.06	33.49	15.64	18.96
2000	-	-	102.52	56.28	55.34	25.84	31.29
2500	-	-	-	83.12	81.71	38.15	46.17
3000	-	-	-	-	112.36	52.45	63.45
4000	-	-	-	-	-	86.7	104.85
5000	-	-	-	-	-	-	154.82

4TW60019-1A (Sheet 2/3)

11 Hydraulic performance

11 - 3 Water pressure drop curve evaporator heating 4-pipe

FWV / FWL / FWM							
Water flow l/h	Water pressure drop						
	FW..01	FW..02	FW..03	FW..04	FW..06	FW..08	FW..10
	kPa	kPa	kPa	kPa	kPa	kPa	kPa
50	0.68	0.68	0.26	0.23	0.21	0.28	0.28
100	2.27	2.78	0.94	0.93	0.7	1.05	0.95
200	7.56	9.25	3.12	3.1	2.33	3.46	3.14
300	15.3	18.74	6.32	6.26	4.7	6.97	6.32
400	25.27	30.94	10.42	10.32	7.75	11.46	10.39
500	37.29	45.66	15.37	15.21	11.42	16.86	15.29
600	51.26	62.76	21.12	20.89	15.67	23.14	20.98
800	84.72	103.72	34.88	34.47	25.86	38.14	34.56
1000	-	-	51.49	50.87	38.16	56.23	50.94
1500	-	-	-	103.2	77.4	113.95	103.2

4TW60019-1A (Sheet 3/3)

TABLE OF CONTENTS

FWD

1	Features	43
2	Specifications	44
	Nominal capacity and nominal input	44
	Technical Specifications	45
	Electrical Specifications	47
3	Electrical data	48
4	Options	49
5	Control systems	50
6	Capacity tables	51
	Cooling capacity tables - 2-pipe / 4-pipe	51
	Capacity tables with glycol for process cooling applications	54
	Heating capacity tables - 2-pipe	55
	Heating capacity tables - 4-pipe	57
	Power consumption - 2-pipe / 4-pipe	59
	Capacity correction factor	64
7	Dimensional drawing & centre of gravity	65
	Dimensional drawing	65
8	Wiring diagram	67
	Wiring diagram	67
9	Sound data	68
	Sound level data - 2-pipe / 4-pipe	68
10	Installation	72
	Installation method	72
11	Operation range	77
12	Hydraulic performance	78
	Water pressure drop curve evaporator cooling 2-pipe	78
	Water pressure drop curve evaporator heating 2-pipe	78
	Water pressure drop curve evaporator heating 4-pipe	79

1 Features

- Possibility of installation both in horizontal and vertical position
- Standard air filter : removable from the bottom
- Straight duct connector is mounted to discharge side



2

1

2 Specifications

2-1 NOMINAL CAPACITY AND NOMINAL INPUT			FWD04AATN	FWD06AATN	FWD08AATN	FWD10AATN	FWD012AATN	FWD016AATN	FWD018AATN	
Power Input	High		W	234	349	443	443	714	1197	1197
	Medium		W	173	294	336	336	473	966	966
	Low		W	130	247	261	261	328	704	704
Cooling capacity	Total capacity	High	kW	3.90	6.20	7.80	8.82	11.90	16.40	18.30
	Sensible capacity	High	kW	3.08	4.65	6.52	7.16	9.36	12.80	14.10
Heating capacity (2-pipe)	High		kW	4.05	7.71	9.43	10.79	14.45	19.81	21.92

2-1 NOMINAL CAPACITY AND NOMINAL INPUT			FWD04AAFN	FWD06AAFN	FWD08AAFN	FWD10AAFN	FWD012AAFN	FWD016AAFN	FWD018AAFN	
Power Input	High		W	234	349	443	443	714	1197	1197
	Medium		W	173	294	336	336	473	966	966
	Low		W	130	247	261	261	328	704	704
Cooling capacity	Total capacity	High	kW	3.90	6.20	7.80	8.82	11.90	16.40	18.30
	Sensible capacity	High	kW	3.08	4.65	6.52	7.16	9.36	12.80	14.10
Heating capacity (4-pipe)	High		kW	4.49	6.62	9.21	9.21	15.86	21.15	21.15

2 Specifications

2-2 TECHNICAL SPECIFICATIONS				FWD04AATN	FWD06AATN	FWD08AATN	FWD10AATN	FWD012AATN	FWD016AATN	FWD018AATN
Dimensions	Unit	Height	mm	280	280	280	280	352	352	352
		Width	mm	754	964	1174	1174	1174	1384	1384
		Depth	mm	559	559	559	559	718	718	718
Weight	Machine weight	kg	33	41	47	49	65	77	80	
Material	Galvanised sheet metal									
Colour	Not painted (galvanised)									
Sound level	Sound power	High	dBA	66	69	72	72	74	78	78
		Medium	dBA	61	63	67	67	67	73	73
		Low	dBA	54	59	62	62	60	69	69
Water flow	Cooling	l/h	674	1064	1339	1514	2056	2833	3140	
	Heating	l/h	674	1064	1339	1514	2056	2833	3140	
Water pressure drop	Cooling	kPa	17	24	24	16	26	34	45	
	Heating	kPa	14	20	20	13	21	28	37	
Fan	Type	Centrifugal multi-blade, double suction								
	Air flow rate	High	m ³ /h	800	1250	1600	1600	2200	3000	3000
	Available pressure	High	Pa	66	58	68	64	97	145	134
	Speed	3 steps : high, medium, low								
	Quantity			1	2	2	2	2	2	2
Motor	Type	Closed induction, B class insulation, winding thermal cut-out								
Standard heat exchanger	Rows	mm	3	3	3	4	3	4	5	
	Stages	mm	10	10	10	10	14	14	14	
	Fin pitch	mm	2.1	1.8	2.1	2.1	2.1	2.1	2.1	
	Face area	m ²	0.138	0.1905	0.243	0.243	0.3402	0.4137	0.4137	
	Water volume	l	1.06	1.42	1.79	2.38	2.5	4.02	5.03	
Air filter	Acrylic - Filtering class EU2									
Insulation material	Class 1 self-extinguishing									
Vibration insulation	Rubber ring for fan motor									
Water connections	Std. heat exchanger	inch	3/4	3/4	3/4	3/4	1	1	1	
Drain		mm	16	16	16	16	16	16	16	
Notes	Rating conditions cooling 2 pipe: air 27									
	Rating conditions heating 2 pipe : air 20									
	Maximum Power input at 0 Pa ESP									
	Sound level at 0 Pa ESP									

2

2

2 Specifications

2-2 TECHNICAL SPECIFICATIONS				FWD04AAFN	FWD06AAFN	FWD08AAFN	FWD10AAFN	FWD012AAFN	FWD016AAFN	FWD018AAFN
Dimensions	Unit	Height	mm	280	280	280	280	352	352	352
		Width	mm	754	964	1174	1174	1174	1384	1384
		Depth	mm	559	559	559	559	718	718	718
Weight	Machine weight	kg	35	43	50	52	71	83	86	
Material				Galvanised sheet metal						
Colour				Not painted (galvanised)						
Sound level	Sound power	High	dBA	66	69	72	72	74	78	78
		Medium	dBA	61	63	67	67	67	73	73
		Low	dBA	54	59	62	62	60	69	69
Water flow	Cooling	l/h	674	1064	1339	1514	2056	2833	3140	
	Heating	l/h	349	581	808	808	1392	1856	1856	
Water pressure drop	Cooling	kPa	17	24	24	16	26	34	45	
	Heating	kPa	9	15	13	13	12	16	16	
Fan	Type			Centrifugal multi-blade, double suction						
	Air flow rate	High	m³/h	800	1250	1600	1600	2200	3000	3000
	Available pressure	High	Pa	63	53	63	59	92	138	128
	Speed			3 steps : high, medium, low						
	Quantity			1	2	2	2	2	2	2
Motor	Type			Closed induction, B class insulation, winding thermal cut-out						
Standard heat exchanger	Rows	mm	3	3	3	4	3	4	5	
	Stages	mm	10	10	10	10	14	14	14	
	Fin pitch	mm	2.1	1.8	2.1	2.1	2.1	2.1	2.1	
	Face area	m²	0.138	0.1905	0.243	0.243	0.3402	0.4137	0.4137	
	Water volume	l	1.06	1.42	1.79	2.38	2.50	4.02	5.03	
Additional heat exchanger	Rows	mm	1	1	1	1	2	2	2	
	Stages	mm	10	10	10	10	12	12	12	
	Fin pitch	mm	1.8	1.8	1.8	1.8	2.1	2.1	2.1	
	Face area	m²	0.138	0.1905	0.243	0.243	0.3402	0.4137	0.4137	
	Water volume	l	0.35	0.47	0.59	0.59	1.42	1.72	1.72	
Air filter				Acrylic - Filtering class EU2						
Insulation material				Class 1 self-extinguishing						
Vibration insulation				Rubber ring for fan motor						
Water connections	Std. heat exchanger	inch	3/4	3/4	3/4	3/4	1	1	1	
Drain			mm	16	16	16	16	16	16	
Notes				Rating conditions 4-pipe: air 27°CDB - 19°CWB - entering water 7°C - leaving water 12°C at nominal air flow and ESP						
				Rating conditions 4-pipe: air 20°CDB - entering water 70°C - leaving water 60°C at nominal air flow and ESP						
				Maximum Power input at 0 Pa ESP						
				Sound level at 0 Pa ESP						

2 Specifications

2-3 ELECTRICAL SPECIFICATIONS			FWD04AATN	FWD06AATN	FWD08AATN	FWD10AATN	FWD012AATN	FWD016AATN	FWD018AATN
Current input	High	A	0.95	1.58	1.97	1.97	3.21	5.37	5.37
	Medium	A	0.74	1.39	1.52	1.52	2.08	4.38	4.38
	Low	A	0.57	1.18	1.20	1.20	1.50	3.26	3.26
Required power supply	V / f / Hz	230/1/50							
Required fuses	A	2	2	2	4	4	6	6	
Required wire section	mm ²	1	1	1.5	1.5	2	2.5	2.5	
Notes		Current input at 0 Pa ESP							
		For more details concerning conditional connections, see http://www.daikineurope.com , select E-data Books. Finally click on the document title of your choice							

2-3 ELECTRICAL SPECIFICATIONS			FWD04AAF N	FWD06AAF N	FWD08AAF N	FWD10AAF N	FWD012AAF N	FWD016AAF N	FWD018AAF N
Current input	High	A	0.95	1.58	1.97	1.97	3.21	5.37	5.37
	Medium	A	0.74	1.39	1.52	1.52	2.08	4.38	4.38
	Low	A	0.57	1.18	1.20	1.20	1.50	3.26	3.26
Required power supply	V / f / Hz	230/1/50							
Required fuses	A	2	2	2	4	4	6	6	
Required wire section	mm ²	1	1	1.5	1.5	2	2.5	2.5	
Notes		Current input at 0 Pa ESP							
		For more details concerning conditional connections, see http://www.daikineurope.com , select E-data Books. Finally click on the document title of your choice							

2

2

3 Electrical data

FWD		Power input electric heater	Current Absorption	Power supply
Unit	Electric heater	kW	A	V / ~ / Hz
FWD04	EDEHS04A6	2.0	8.7	230V +- 10% / 1~ / 50Hz
FWD06	EDEHS06A6	3.0	4.3	400V +- 10% / 3~ / 50Hz
	EDEHB06A6	6.0	8.7	
FWD08	EDEHS10A6	4.5	6.5	400V +- 10% / 3~ / 50Hz
	EDEHB10A6	9.0	13.0	
FWD10	EDEHS10A6	4.5	6.5	400V +- 10% / 3~ / 50Hz
	EDEHB10A6	9.0	13.0	
FWD12	EDEHS12A6	4.5	6.5	400V +- 10% / 3~ / 50Hz
	EDEHB12A6	9.0	13.0	
FWD16	EDEHS18A6	9.0	13.0	400V +- 10% / 3~ / 50Hz
	EDEHB18A6	12.0	17.3	
FWD18	EDEHS18A6	9.0	13.0	400V +- 10% / 3~ / 50Hz
	EDEHB18A6	12.0	17.3	

4TW60221-3

4 Options

FWD		04	06	08	10	12	16	18	Notes/Remarks
Electric heater	EDEH(S)(B).A6	EDEH04A6	EDEH(S)(B)06A6	EDEH(S)(B)10A6		EDEH(S)(B)12A6	EDEH(S)(B)18A6		Requires electronic controller
2-pipe ON-OFF 3 way motor driven valve complete with mounting kit	ED2MV.A6	ED2MV04A6	ED2MV10A6			ED2MV12A6	ED2MV18A6		For FWD12-16-18 only motor valve (piping not included)
4-pipe ON-OFF 3 way motor driven valve complete with mounting kit	ED4MV.A6	ED4MV04A6	ED4MV10A6			2 x ED2MV12A6	2 x ED2MV18A6		For FWD12-16-18 only motor valve (piping not included)
Fan stop thermostat	YFSTA6	YFSTA6							
Motorised fresh air intake louvers	EDMFA.A6	EDMFA04A6	EDMFA06A6	EDMFA10A6		EDMFA12A6	EDMFA18A6		
Controller electrical remote + water probe + power contactor	ECFWDER6	ECFWDER6							
Auxiliary drain pan (vertical models)	EDDPV.A6	EDDPV10A6				EDDPV18A6			











4TW60229-2A (Sheet 1/2)

2
4

FWD		Electric heater	2-pipe ON-OFF 3 way motor driven valve complete with mounting kit	4-pipe ON-OFF 3 way motor driven valve complete with mounting kit	Fan stop thermostat	Motorised fresh air intake louvers	Controller electrical remote + water probe + power contactor	Auxiliary drain pan (vertical models)
		EDEH(S)(B).A6	ED2MV.A6	ED4MV.A6	YFSTA6	EDMFA.A6	ECFWDER6	EDDPV.A6
Electric heater	EDEH(S)(B).A6		X			X	X	X
2-pipe ON-OFF 3 way motor driven valve complete with mounting kit	ED2MV.A6	X				X	X	X
4-pipe ON-OFF 3 way motor driven valve complete with mounting kit	ED4MV.A6					X	X	X
Fan stop thermostat	YFSTA6					X		X
Motorised fresh air intake louvers	EDMFA.A6	X	X	X	X		X	X
Controller electrical remote + water probe + power contactor	ECFWDER6	X	X	X		X		X
Auxiliary drain pan (vertical and horizontal models)	EDDPV.A6	X	X	X		X		X
Auxiliary drain pan (vertical models)	EDDPV.A6	X	X	X	X	X	X	

4TW60229-2A (Sheet 2/2)

5 Control systems

	Cool/heat changeover			Options		Basic control functions		Control features		
										
2-pipe	X					X	X	X	X	
	X			X		X	X		X	
	X				X	X	X	X	X	
	X			X	X	X	X		X	
		X				X	X	X		
		X		X		X	X			
			X		X	X	X	X	X	X
4-pipe	X			X		X	X		X	
	X					X	X	X	X	
			X			X	X	X		X
			X	X		X	X		X	X



Manual cool/heat changeover.



Automatic cool/heat changeover based on water temperature.



Automatic cool/heat changeover based on air temperature.



Control of the 3-way/4pipe ON/OFF valve. The water valve shut-off once the desired temperature is reached.



The controller controls the electric heater as integration or replacement of the hot water heating system. When the operating mode selector switch is turned on "electric heater" and the electric heater is turned on, the fan runs continuously at medium speed. When the operating mode selector switch is turned to "electric heater" and the electric heater is turned on, the fan runs continuously at medium speed.



The fan speed can be set at one of the 3 speeds (low, medium or maximum) by turning the operation mode selector.



The fan speed is switched automatically based on the difference between the temperature set on the thermostat and the room temperature.



Optimised comfort cooling. When the fan coil has reached the desired setpoint, the fan will operate at medium speed and at regular intervals to ensure constant room temperature and lower sound.



The controller prevents the fan coil unit from operating in one mode, if the required water temperature is not achieved to operate in the selected mode.



The dead zone is a temperature interval close to the set temperature. When the air is warmer/cooler than the top/lower limit of the neutral zone, the cooling/heating mode is selected.

6 Capacity tables

6 - 1 Cooling capacity tables - 2-pipe / 4-pipe

2
6

Air temperature (°C DB - °C WB) Water temperature (Entering °C - leaving °C)		22 - 16						9 - 14					
		6 - 11			7 - 12			8 - 13			9 - 14		
Model	Air flow m ³ /h	Total cooling capacity W	Sensible cooling capacity W	Water flow ℓ/h	Water pressure drop kPa	Total cooling capacity W	Sensible cooling capacity W	Water flow ℓ/h	Water pressure drop kPa	Total cooling capacity W	Sensible cooling capacity W	Water flow ℓ/h	Water pressure drop kPa
FWD04	400	1410	1250	241	3	1150	1150	197	2	1050	1050	180	2
	600	1850	1720	317	5	1440	1440	247	3	1310	1310	226	2
	800	2370	2200	406	7	1790	1790	307	4	1570	1570	269	3
	1000	2550	2290	437	5	2000	2000	343	3	1830	1830	314	3
FWD06	1250	3160	2780	542	7	2360	2360	405	4	2050	2050	352	3
	1250	3810	3320	653	10	2830	2830	486	6	2490	2490	427	5
	1200	3470	3470	595	6	2750	2750	472	4	2500	2500	429	3
	1400	3930	3930	674	7	3150	3150	541	5	2720	2720	468	4
FWD10	1600	4360	4360	748	9	3520	3520	604	6	3070	3070	528	5
	1200	3830	3830	657	4	3280	3280	563	3	3000	3000	515	2
	1400	4320	4320	742	5	3560	3560	612	3	3260	3260	560	3
	1600	4870	4870	835	6	3840	3840	660	4	3490	3490	600	3
FWD12	1600	5600	5080	961	7	4130	4130	709	4	3630	3630	624	3
	1900	6550	5940	1123	9	4810	4810	825	5	4200	4200	721	4
	2000	6840	6210	1174	10	5420	5420	931	7	4770	4770	819	5
	2000	7760	6650	1331	9	5350	5350	919	5	4780	4780	820	4
FWD16	2500	9350	8100	1604	13	6470	6470	1111	7	5730	5730	984	5
	3000	10790	9460	1851	16	7480	7480	1284	8	6660	6660	1144	7
	2000	9140	7440	1569	13	6060	6060	1041	6	5430	5430	932	5
	2500	10930	9070	1875	18	7280	7280	1250	9	6540	6540	1124	7
3000	12570	10630	2156	23	8400	8400	1443	11	7560	7560	1298	9	

4TW60222-1 (Sheet 1/7)

6 Capacity tables

6 - 1 Cooling capacity tables - 2-pipe / 4-pipe

Air temperature (°C DB - °C WB) Water temperature (Entering °C - leaving °C)		25 - 18						9 - 14						
		6 - 11			7 - 12			8 - 13			9 - 14			
Model	Air flow m ³ /h	Total cooling capacity W	Sensible cooling capacity W	Water flow ℓ/h	Water pressure drop kPa	Water pressure drop kPa	Total cooling capacity W	Sensible cooling capacity W	Water flow ℓ/h	Water pressure drop kPa	Total cooling capacity W	Sensible cooling capacity W	Water flow ℓ/h	Water pressure drop kPa
FWD04	400	2170	1620	371	6	5	1460	1350	252	3	1330	1330	227	3
	600	3010	2270	515	11	8	2110	1930	364	6	1800	1800	310	4
	800	3740	2860	641	16	12	2660	2450	457	9	2240	2240	385	6
	1000	4220	3070	724	12	9	2960	2580	508	6	2490	2490	428	5
FWD06	1250	5030	3660	968	17	13	3580	3100	616	9	2990	2990	511	7
	1200	6020	4740	1032	23	17	4310	3690	740	13	3540	3540	609	9
	1400	6770	5400	1161	19	14	4370	3870	666	7	3550	3550	608	6
	1600	7470	6040	1282	22	17	4830	4370	749	9	4010	4010	688	7
FWD10	1200	6650	5130	1141	10	7	4260	4260	731	4	3870	3870	666	4
	1400	7570	5900	1300	12	9	4870	4870	835	6	4450	4450	763	5
	1600	8440	6640	1447	15	11	5450	5450	936	7	4990	4990	857	6
	1600	8930	6680	1530	16	12	6380	5680	1098	9	5250	5250	904	6
FWD12	1900	10220	7720	1753	20	16	7370	6610	1267	11	6030	6030	1037	8
	2200	11420	8710	1958	24	19	8280	7490	1422	14	6760	6760	1159	10
	2000	11600	8520	1987	18	15	8640	7340	1483	11	6670	6670	1145	7
	2500	13770	10270	2362	25	20	10330	8910	1775	15	7970	7970	1368	9
FWD16	3000	15780	11930	2707	32	25	11870	10410	2038	19	9150	9150	1573	12
	2000	12920	9310	2218	25	20	9990	8110	1714	15	8300	7450	1426	11
	2500	15380	11280	2635	33	27	11900	9880	2045	21	9940	9120	1706	15
	3000	17650	13180	3028	42	34	13670	11590	2347	27	11440	10740	1966	20

4TW60222-1 (Sheet 2/7)

6 Capacity tables

6 - 1 Cooling capacity tables - 2-pipe / 4-pipe

2

6

Air temperature (°C DB - °C WB) Water temperature (Entering °C - leaving °C)		27 - 19						8 - 13						9 - 14					
		6 - 11		7 - 12		8 - 13		9 - 14		6 - 11		7 - 12		8 - 13		9 - 14			
Model	Air flow m ³ /h	Total cooling capacity W	Sensible cooling capacity W	Water flow ℓ/h	Water pressure drop kPa	Total cooling capacity W	Sensible cooling capacity W	Water flow ℓ/h	Water pressure drop kPa	Total cooling capacity W	Sensible cooling capacity W	Water flow ℓ/h	Water pressure drop kPa	Total cooling capacity W	Sensible cooling capacity W	Water flow ℓ/h	Water pressure drop kPa		
FWD04	400	2580	1870	443	8	2280	1750	392	7	1950	1620	335	5	1570	1480	270	3		
	600	3560	2600	608	14	3150	2450	540	12	2720	2290	468	9	2250	2110	385	6		
	800	4400	3270	756	21	3900	3080	674	17	3390	2890	583	13	2660	2660	457	9		
	1000	4990	3520	857	16	4430	3300	760	13	3830	3070	659	10	3160	2820	544	7		
FWD06	1250	5920	4180	1015	22	5270	3990	904	18	4570	3660	785	14	3800	3380	652	10		
	1500	6970	4940	1195	29	6200	4650	1064	24	5380	4340	924	19	4500	4020	772	13		
	1750	7100	5420	1217	20	6310	5110	1084	17	5460	4790	936	13	4230	4230	727	8		
	2000	7970	6160	1368	25	7090	5820	1217	20	6150	5470	1055	16	4760	4760	817	10		
FWD10	1600	8790	6890	1508	30	7800	6520	1339	24	6800	6130	1166	19	5260	5260	904	12		
	1800	9970	7910	1710	13	8990	7530	1499	11	7990	7140	1310	8	6090	6090	1006	5		
	2000	10970	8660	1537	17	9590	8160	1364	13	8640	7990	1474	10	6740	6740	1106	7		
	2200	11970	9670	1710	20	9820	9160	1514	16	9160	8820	1606	12	7460	7460	1222	8		
FWD12	1600	10490	7630	1800	21	9350	7170	1606	17	8130	6700	1310	12	5950	5950	1022	8		
	1900	11970	8800	2056	26	10690	8290	1832	22	9310	7760	1598	17	7800	7200	1166	10		
	2200	13370	9920	2293	32	11900	9360	2056	26	10410	8780	1786	20	8740	8170	1339	12		
	2500	15950	11640	2308	24	12100	9130	2077	20	10660	8560	1829	16	9100	7970	1501	15		
FWD16	2000	13450	9670	2308	24	12100	9130	2077	20	10660	8560	1829	16	9100	7970	1501	15		
	2500	15950	11640	2736	32	14360	11010	2466	27	12670	10360	2178	21	10850	9670	1865	16		
	3000	18260	13510	3136	41	16400	12800	2833	34	14520	12060	2491	27	12450	11290	2138	21		
	2000	14790	10490	2538	31	13430	9930	2304	26	11990	9350	2059	21	10440	8740	1793	17		
FWD18	2500	17610	12710	3020	42	15990	12050	2743	35	14270	11370	2448	29	12430	10660	2135	23		
	3000	20150	14820	3456	53	18300	14100	3140	45	16370	13320	2812	37	14270	12520	2452	29		

4TW60222-1 (Sheet 3/7)

6 Capacity tables

6 - 2 Capacity tables with glycol for process cooling applications

Cooling mode

Glycol percentage in weight	Freezing temperature (°C)	Capacity correction factor	Pressure drop correction factor
0	0	1	1.00
10	-4	0.93	1.09
20	-10	0.84	1.18
30	-16	0.76	1.27
40	-24	0.76	1.36

Heating mode

Glycol percentage in weight	Freezing temperature (°C)	Capacity correction factor	Pressure drop correction factor
0	0	1	1.00
10	-4	0.98	1.08
20	-10	0.97	1.11
30	-16	0.94	1.22
40	-24	0.91	1.33

4TW60228-1B

Correction factors are based on an average value (at rated water flow rate). This can cause deviation depending on conditions used. The Fan Coil Selection software will provide an accurate result at all conditions.

6 Capacity tables

6 - 3 Heating capacity tables - 2-pipe

2
6

Air temperature (°C) Water temperature (Entering °C - leaving °C)		20													
		50 - 45				60 - 50				70 - 60				90 - 70	
Model	Air flow m ³ /h	Heating capacity W	Water flow ℓ/h	Water pressure drop kPa	Heating capacity W	Water flow ℓ/h	Water pressure drop kPa	Heating capacity W	Water flow ℓ/h	Water pressure drop kPa	Heating capacity W	Water flow ℓ/h	Water pressure drop kPa		
FWD04TN	400	3010	526	9	3830	335	4	4970	436	6	6660	295	3		
	600	4070	709	15	5160	450	7	6700	587	10	8940	396	5		
	800	4990	871	22	6300	551	9	8200	720	15	10910	482	7		
	1000	5760	1004	18	7320	641	8	9490	832	12	12690	562	6		
FWD06TN	1250	6790	1181	23	8600	752	10	11170	979	16	14900	659	7		
	1500	7960	1386	31	10050	878	13	13080	1147	21	17400	768	10		
	1800	9200	1579	21	11330	976	9	14520	1274	17	19320	853	8		
	2100	10440	1750	25	12740	1069	11	15920	1397	20	21150	932	9		
FWD10TN	1600	8940	1559	14	11380	994	6	14730	1292	9	19730	871	4		
	1800	10040	1750	17	12740	1112	7	16530	1451	11	22090	976	5		
	2000	11080	1930	20	14040	1228	9	18230	1598	13	24330	1073	6		
	2200	12120	2108	21	14960	1307	9	19380	1699	14	25930	1145	7		
FWD12TN	1900	13350	2326	27	16930	1480	12	21970	1930	18	29340	1296	9		
	2100	14830	2585	32	18770	1638	14	24400	2142	21	32520	1436	10		
	2300	16010	2617	24	19180	1678	11	24740	2171	16	33240	1465	8		
	2500	17750	3092	32	22600	1976	14	29200	2563	22	39140	1728	10		
FWD16TN	3000	20270	3528	41	25760	2250	18	33350	2927	27	44570	1966	13		
	3500	22870	4037	31	28970	2582	14	36890	3358	21	48350	2212	10		
	4000	25380	4584	42	32040	2978	19	40400	3812	28	52180	2504	14		
	4500	27840	5172	53	35900	3428	24	45110	4329	36	58110	2815	17		

4TW60222-1 (Sheet 4/7)

6 Capacity tables

6 - 3 Heating capacity tables - 2-pipe

Air temperature (°C) Water temperature (Entering °C - leaving °C)		22											
		50 - 45			60 - 50			70 - 60			90 - 70		
Model	Air flow m ³ /h	Heating capacity W	Water flow ℓ/h	Water pressure drop kPa	Heating capacity W	Water flow ℓ/h	Water pressure drop kPa	Heating capacity W	Water flow ℓ/h	Water pressure drop kPa	Heating capacity W	Water flow ℓ/h	Water pressure drop kPa
FWD04TN	400	2780	486	8	3590	313	4	4730	415	6	6410	283	3
	600	3760	655	13	4840	423	6	6380	560	9	8600	380	5
	800	4610	803	19	5910	517	8	7810	685	13	10500	463	6
FWD06TN	800	5320	929	15	6870	624	7	9040	793	11	12230	540	5
	1000	6270	1091	20	8070	705	9	10630	933	14	14340	633	7
	1250	7340	1279	27	9430	824	12	12450	1092	19	16750	739	9
FWD08TN	1200	7310	1274	18	9420	823	8	12410	1089	13	16730	739	6
	1400	8830	1541	25	10480	915	10	13830	1213	15	18610	821	7
	1600	9690	1688	29	11470	1002	11	15150	1330	18	20370	899	9
FWD10TN	1200	8250	1436	12	10680	933	5	14030	1230	8	19000	839	4
	1400	9270	1614	15	11960	1045	7	15740	1381	10	21720	939	5
	1600	10220	1781	17	13170	1151	8	17350	1523	12	23420	1034	6
FWD12TN	1600	10860	1892	19	14040	1227	8	18440	1619	13	24980	1102	6
	1900	12320	2146	23	15890	1388	10	20920	1835	16	28250	1247	8
	2200	13690	2384	28	17610	1539	13	23220	2038	20	31310	1382	10
FWD16TN	2000	13870	2416	21	18020	1574	10	23560	2067	15	32010	1414	7
	2500	16390	2855	28	21320	1855	13	27820	2442	20	37710	1664	10
	3000	18720	3260	35	24190	2113	16	31750	2787	25	42930	1896	12
FWD18TN	2000	15060	2624	27	19710	1722	12	25610	2248	19	35030	1546	9
	2500	17960	3129	36	23420	2047	17	30520	2677	26	41600	1837	13
	3000	20650	3598	46	26870	2347	21	35060	3077	33	47700	2106	16

4TW60222-1 (Sheet 5/7)

6 Capacity tables

6 - 4 Heating capacity tables - 4-pipe

2
6

Air temperature (°C) Water temperature (Entering °C - leaving °C)		20											
		50 - 45		60 - 50		70 - 60		90 - 70					
Model	Air flow m ³ /h	Heating capacity W	Water flow ℓ/h	Water pressure drop kPa	Heating capacity W	Water flow ℓ/h	Water pressure drop kPa	Heating capacity W	Water flow ℓ/h	Water pressure drop kPa			
FWD04FN	400	1950	338	7	2370	209	3	3190	281	5	4150	184	2
	600	2390	418	11	2930	256	4	3920	346	7	5090	223	3
	800	2740	479	13	3360	292	6	4490	396	9	5820	256	4
	1000	3280	569	16	4060	356	7	5370	472	10	7030	310	5
FWD06FN	1250	3650	634	19	4510	392	8	5970	526	13	7800	346	6
	1500	4040	704	22	4990	436	9	6620	581	15	8620	381	7
	1200	4900	853	15	6040	526	6	8030	706	10	10460	461	5
	1400	5280	918	17	6490	569	7	8650	760	12	11250	497	5
FWD10FN	1600	5620	979	19	6900	605	8	9210	806	13	11960	529	6
	1200	4900	853	15	6040	526	6	8030	706	10	10460	461	5
	1400	5280	918	17	6490	569	7	8650	760	12	11250	497	5
	1600	5620	979	19	6900	605	8	9210	806	13	11960	529	6
FWD12FN	1600	7930	1382	13	9880	864	5	13020	1141	9	17110	756	4
	1900	8840	1541	15	10990	961	7	14500	1271	10	19020	839	5
	2200	9670	1685	18	12010	1051	8	15860	1393	12	20790	918	6
	2000	10020	1746	15	12540	1094	6	16450	1444	10	21690	958	5
FWD16FN	2500	11530	2009	19	14400	1260	8	18920	1660	13	24900	1098	6
	3000	12900	2246	23	16080	1404	10	21150	1854	16	27790	1228	7
	2000	10020	1746	15	12540	1094	6	16450	1444	10	21690	958	5
	2500	11530	2009	19	14400	1260	8	18920	1660	13	24900	1098	6
FWD18FN	3000	12900	2246	23	16080	1404	10	21150	1854	16	27790	1228	7

4TW60222-1 (Sheet 6/7)

6 Capacity tables

6 - 4 Heating capacity tables - 4-pipe

Air temperature (°C) Water temperature (Entering °C - leaving °C)		22															
		50 - 45				60 - 50				70 - 60				90 - 70			
		Heating capacity W	Water flow ℓ/h	Water pressure drop kPa	Water pressure drop kPa	Heating capacity W	Water flow ℓ/h	Water pressure drop kPa	Water pressure drop kPa	Heating capacity W	Water flow ℓ/h	Water pressure drop kPa	Water pressure drop kPa	Heating capacity W	Water flow ℓ/h	Water pressure drop kPa	
FWD04FN	400	1790	313	6	2210	194	3	3030	266	4	3990	176	2				
	600	2200	385	9	2730	238	4	3730	328	6	4900	216	3				
	800	2520	439	12	3130	274	5	4270	374	8	5590	248	4				
FWD06FN	800	3020	526	13	3800	331	6	5110	446	10	6760	299	4				
	1000	3360	587	16	4220	367	7	5680	500	11	7510	331	5				
	1250	3720	648	19	4670	408	8	6290	552	14	8300	366	6				
FWD08FN	1200	4510	785	13	5640	493	6	7630	670	9	10060	443	4				
	1400	4860	846	15	6070	529	6	8220	720	11	10820	479	5				
	1600	5170	900	17	6450	565	7	8750	767	12	11500	508	6				
FWD10FN	1600	7310	1274	11	9250	810	5	12380	1087	8	16460	727	4				
	1900	8140	1418	13	6970	608	8	13790	1210	9	18310	806	4				
	2200	8910	1552	16	11250	983	7	15090	1325	11	20010	882	5				
FWD16FN	2000	9240	1609	13	11760	1026	6	15650	1372	9	20880	922	4				
	2500	10630	1854	17	13490	1177	7	18000	1580	12	23970	1058	6				
	3000	11890	2070	20	15070	1318	9	20130	1764	14	26760	1181	7				
FWD18TN	2000	9240	1609	13	11760	1026	6	15650	1372	9	20880	922	4				
	2500	10630	1854	17	13490	1177	7	18000	1580	12	23970	1058	6				
	3000	11890	2070	20	15070	1318	9	20130	1764	14	26760	1181	7				

4TW60222-1 (Sheet 7/7)

6 Capacity tables

6 - 5 Power consumption - 2-pipe / 4-pipe

2
6

FWD04	Max.		Med.		Min.	
	Power input	Current	Power input	Current	Power input	Current
ESP	(W)	(A)	(W)	(A)	(W)	(A)
0	234	0.954	173	0.740	130	0.568
10	228	0.946	169	0.740	122	0.550
20	221	0.940	165	0.731	120	0.530
30	211	0.912	161	0.720	117	0.525
40	203	0.890	157	0.702	114	0.514
50	196	0.857	148	0.655	112	0.496
60	182	0.792	144	0.633	109	0.485
70	173	0.754	140	0.616	107	0.473
80	166	0.710	132	0.573	104	0.456
90	158	0.671	125	0.545	100	0.444
100	153	0.639	120	0.520	95	0.419
120	141	0.594	112	0.477	85	0.375
140	130	0.542	97	0.428	77	0.327
160	115	0.471				

4TW60221-2

SYMBOLS

ESP: External static pressure

FWD06	Max.		Med.		Min.	
	Power input	Current	Power input	Current	Power input	Current
ESP	(W)	(A)	(W)	(A)	(W)	(A)
0	349	1.575	294	1.389	247	1.183
10	329	1.530	275	1.322	238	1.150
20	317	1.490	263	1.287	230	1.120
30	303	1.470	256	1.246	225	1.092
40	295	1.430	246	1.194	218	1.065
50	286	1.380	237	1.159	210	1.036
60	274	1.340	228	1.115	204	1.001
70	264	1.306	218	1.078	199	0.974
80	256	1.265	212	1.038	187	0.933
90	246	1.220	200	0.986	180	0.885
100	235	1.170	191	0.951	170	0.849
110	224	1.130	183	0.910	159	0.791
120	212	1.090	167	0.841	145	0.730
130	192	1.010	154.0	0.790	136	0.691
140	178	0.967	140.0	0.725	120	0.623
150	161	0.905	126.0	0.688	114	0.598
160	152	0.880				

4TW60221-2

SYMBOLS

ESP: External static pressure

6 Capacity tables

6 - 5 Power consumption - 2-pipe / 4-pipe

FWD08	Max.		Med.		Min.	
	Power input	Current	Power input	Current	Power input	Current
ESP	(W)	(A)	(W)	(A)	(W)	(A)
0	443	1.971	336	1.515	261	1.204
10	420	1.915	317	1.475	247	1.186
20	404	1.850	301	1.418	238	1.144
30	382	1.808	290	1.366	231	1.106
40	367	1.715	279	1.330	221	1.045
52	353	1.670	262	1.246	212	1.008
60	335	1.582	251	1.189	203	0.972
70	315	1.508	248	1.163	195	0.935
80	302	1.430	233	1.109	186	0.885
90	280	1.350	221	1.045	176	0.839
100	267	1.292	210	0.994	168	0.804
110	254	1.224	198	0.936	155	0.741
120	238	1.166	185	0.889	146	0.705
130	225	1.106	172	0.826	135	0.648
140	203	1.028	155	0.746	126	0.605
150	193	0.970	142	0.682	118	0.576
160	174	0.897				

4TW60221-2

SYMBOLS

ESP: External static pressure

FWD10	Max.		Med.		Min.	
	Power input	Current	Power input	Current	Power input	Current
ESP	(W)	(A)	(W)	(A)	(W)	(A)
0	443	1.971	336	1.515	261	1.204
10	420	1.915	317	1.475	247	1.186
20	404	1.850	301	1.418	238	1.144
30	382	1.808	290	1.366	231	1.106
40	367	1.715	279	1.330	221	1.045
52	353	1.670	262	1.246	212	1.008
60	335	1.582	251	1.189	203	0.972
70	315	1.508	248	1.163	195	0.935
80	302	1.430	233	1.109	186	0.885
90	280	1.350	221	1.045	176	0.839
100	267	1.292	210	0.994	168	0.804
110	254	1.224	198	0.936	155	0.741
120	238	1.166	185	0.889	146	0.705
130	225	1.106	172	0.826	135	0.648
140	203	1.028	155	0.746	126	0.605
150	193	0.970	142	0.682	118	0.576
160	174	0.897				

4TW60221-2

SYMBOLS

ESP: External static pressure

6 Capacity tables

6 - 5 Power consumption - 2-pipe / 4-pipe

FWD12 ESP	Max.		Med.		Min.	
	Power input	Current	Power input	Current	Power input	Current
(Pa)	(W)	(A)	(W)	(A)	(W)	(A)
0	714	3.210	473	2.080	328	1.500
10	683	3.100	452	2.070	309	1.485
20	663	3.070	440	2.060	303	1.460
30	646	3.020	430	2.040	299	1.438
40	630	2.990	420	1.970	290	1.403
50	620	2.950	415	1.915	287	1.382
60	604	2.895	402	1.900	278	1.338
70	580	2.800	390	1.860	272	1.306
80	570	2.730	380	1.790	267	1.280
90	550	2.650	370	1.730	257	1.236
100	530	2.600	350	1.650	252	1.213
110	520	2.540	340	1.600	249	1.190
120	490	2.450	330	1.540	244	1.173
130	480	2.390	320	1.480	239	1.139
140	450	2.300	310	1.440	235	1.118
150	440	2.225	300	1.380	230	1.100
160	430	2.210				

4TW60221-2

SYMBOLS

ESP: External static pressure

6 Capacity tables

6 - 5 Power consumption - 2-pipe / 4-pipe

FWD16 ESP	Max.		Med.		Min.	
	Power input	Current	Power input	Current	Power input	Current
(Pa)	(W)	(A)	(W)	(A)	(W)	(A)
0	1197	5.370	966	4.380	704	3.260
10	1159	5.300	921	4.200	680	3.250
20	1130	5.250	897	4.090	672	3.240
30	1112	5.200	879	4.046	660	3.200
40	1092	5.100	864	3.986	650	3.150
50	1086	5.090	848	3.930	640	3.080
60	1068	5.060	842	3.910	638	3.010
70	1060	5.020	830	3.883	629	2.990
80	1051	5.000	820	3.823	624	2.963
90	1050	4.960	810	3.774	620	2.958
100	1034	4.930	800	3.693	610	2.930
110	1026	4.900	790	3.620	600	2.870
120	1017	4.880	760	3.540	590	2.830
130	1006	4.850	743	3.480	580	2.790
140	997	4.820	730	3.420	570	2.740
150	985	4.790	717	3.400	556	2.690
160	973	4.760	710	3.350	540	2.600
170	963	4.690	703	3.300	532	2.566
180	944	4.620	680	3.200	520	2.470
190	926	4.550	661	3.133		
200	912	4.493	655	3.120		
210	894	4.405				
220	877	4.313				
230	860	4.215				
240	848	4.150				
250	841	4.117				

4TW60221-2

SYMBOLS

ESP: External static pressure

6 Capacity tables

6 - 5 Power consumption - 2-pipe / 4-pipe

FWD18 ESP	Max.		Med.		Min.	
	Power input	Current	Power input	Current	Power input	Current
(Pa)	(W)	(A)	(W)	(A)	(W)	(A)
0	1197	5.370	966	4.380	704	3.260
10	1159	5.300	921	4.200	680	3.250
20	1130	5.250	897	4.090	672	3.240
30	1112	5.200	879	4.046	660	3.200
40	1092	5.100	864	3.986	650	3.150
50	1086	5.090	848	3.930	640	3.080
60	1068	5.060	842	3.910	638	3.010
70	1060	5.020	830	3.883	629	2.990
80	1051	5.000	820	3.823	624	2.963
90	1050	4.960	810	3.774	620	2.958
100	1034	4.930	800	3.693	610	2.930
110	1026	4.900	790	3.620	600	2.870
120	1017	4.880	760	3.540	590	2.830
130	1006	4.850	743	3.480	580	2.790
140	997	4.820	730	3.420	570	2.740
150	985	4.790	717	3.400	556	2.690
160	973	4.760	710	3.350	540	2.600
170	963	4.690	703	3.300	532	2.566
180	944	4.620	680	3.200	520	2.470
190	926	4.550	661	3.133		
200	912	4.493	655	3.120		
210	894	4.405				
220	877	4.313				
230	860	4.215				
240	848	4.150				
250	841	4.117				

4TW60221-2

SYMBOLS

ESP: External static pressure

6 Capacity tables

6 - 6 Capacity correction factor

ESP (Pa)	0		20		40		60		80		100		120		140		160		180		200		220		240		
	F1	F2	F1	F2	F1	F2	F1	F2	F1	F2	F1	F2	F1	F2	F1	F2	F1	F2	F1	F2	F1	F2	F1	F2	F1	F2	
FWD04	Max.	1.18	1.13	1.09	1.08	1.06	1.02	1.02	0.96	0.97	0.89	0.92	0.80	0.85	0.70	0.77	0.53	0.62	-	-	-	-	-	-	-	-	
	Med.	1.34	1.24	1.28	1.20	1.15	1.13	1.10	1.04	1.03	0.95	0.96	0.82	0.86	0.65	0.71	-	-	-	-	-	-	-	-	-	-	
	Min.	1.44	1.34	1.37	1.29	1.23	1.20	1.16	1.10	1.08	0.97	0.98	0.79	0.82	-	-	-	-	-	-	-	-	-	-	-	-	
FWD06	Max.	1.26	1.19	1.18	1.13	1.09	1.07	0.99	0.88	0.91	0.75	0.81	0.60	0.68	0.40	0.48	-	-	-	-	-	-	-	-	-	-	
	Med.	1.37	1.26	1.28	1.20	1.19	1.13	1.08	1.06	0.97	0.83	0.87	0.67	0.73	0.44	0.50	-	-	-	-	-	-	-	-	-	-	
	Min.	1.47	1.34	1.38	1.28	1.28	1.21	1.17	1.13	1.04	0.90	0.92	0.72	0.77	0.45	0.50	-	-	-	-	-	-	-	-	-	-	
FWD08	Max.	1.28	1.20	1.21	1.15	1.13	1.09	1.04	0.96	0.88	0.74	0.79	0.61	0.68	0.42	0.49	-	-	-	-	-	-	-	-	-	-	
	Med.	1.18	1.13	1.11	1.08	1.03	1.02	0.94	0.96	0.85	0.88	0.74	0.61	0.68	0.42	0.49	-	-	-	-	-	-	-	-	-	-	
	Min.	1.15	1.11	1.08	1.06	1.00	1.00	0.91	0.93	0.82	0.85	0.70	0.56	0.62	0.35	0.41	-	-	-	-	-	-	-	-	-	-	
FWD10	Max.	1.26	1.20	1.18	1.14	1.10	1.08	1.02	1.02	0.92	0.82	0.85	0.70	0.74	0.54	0.60	0.31	0.38	-	-	-	-	-	-	-	-	
	Med.	1.17	1.14	1.10	1.08	1.02	1.02	0.94	0.95	0.84	0.87	0.73	0.60	0.64	0.41	0.46	-	-	-	-	-	-	-	-	-	-	
	Min.	1.14	1.12	1.07	1.06	0.99	0.99	0.91	0.92	0.81	0.83	0.70	0.56	0.57	0.35	0.43	-	-	-	-	-	-	-	-	-	-	
FWD12	Max.	1.35	1.24	1.29	1.21	1.22	1.16	1.15	1.11	1.07	0.99	0.99	0.89	0.92	0.77	0.82	0.61	0.68	-	-	-	-	-	-	-	-	
	Med.	1.16	1.12	1.10	1.08	1.03	1.03	0.96	0.97	0.88	0.91	0.79	0.69	0.74	0.56	0.62	0.35	0.40	-	-	-	-	-	-	-	-	
	Min.	1.02	1.02	0.96	0.97	0.89	0.91	0.82	0.85	0.74	0.78	0.65	0.54	0.59	0.39	0.43	-	-	-	-	-	-	-	-	-	-	
FWD16	Max.	1.13	1.10	1.12	1.09	1.10	1.07	1.08	1.06	1.06	1.05	1.04	1.03	1.02	1.01	1.01	0.98	0.99	0.96	0.98	0.94	0.96	0.92	0.94	0.89	0.92	
	Med.	1.11	1.08	1.09	1.07	1.07	1.05	1.04	1.03	1.02	1.02	1.00	0.97	0.98	0.95	0.96	0.92	0.94	0.89	0.92	0.86	0.89	0.83	0.86	0.79	0.84	
	Min.	1.09	1.07	1.06	1.05	1.03	1.03	1.01	1.01	0.98	0.99	0.95	0.96	0.92	0.94	0.89	0.91	0.86	0.88	0.82	0.85	0.78	0.82	0.74	0.78	0.69	0.74
FWD18	Max.	1.12	1.09	1.11	1.08	1.09	1.06	1.07	1.05	1.05	1.04	1.03	1.01	1.01	1.00	0.99	0.97	0.98	0.95	0.97	0.93	0.95	0.91	0.93	0.88	0.91	
	Med.	1.10	1.07	1.07	1.06	1.05	1.04	1.03	1.02	1.01	1.01	0.98	0.96	0.96	0.93	0.93	0.95	0.90	0.92	0.87	0.90	0.84	0.88	0.81	0.85	0.78	0.82
	Min.	1.08	1.06	1.05	1.04	1.03	1.02	1.00	1.00	0.97	0.98	0.94	0.91	0.93	0.88	0.90	0.84	0.87	0.81	0.84	0.77	0.81	0.72	0.77	0.67	0.72	

4TW60228-1A

Conditions

Cooling

Heating 2-pipe

Heating 4-pipe

Air: 27°C DB - 19°C WB - Water: entering 7°C - leaving 12°C

Air: 20°C Water: entering 50°C water flow as for cooling

Air: 20°C Water: entering 70°C - leaving 60°C

F1 = correction factor for air flow

F2 = correction factor for capacities

The correction factor is applicable also for 4 pipe and heating mode because the differences are negligible.

7 Dimensional drawing & centre of gravity

7 - 1 Dimensional drawing

FWD04-06-08-10

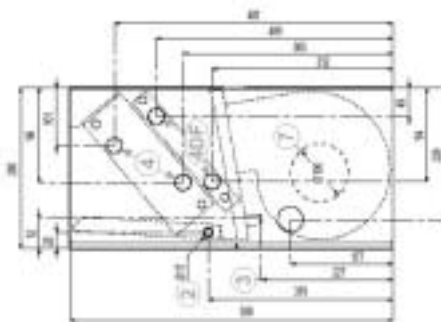
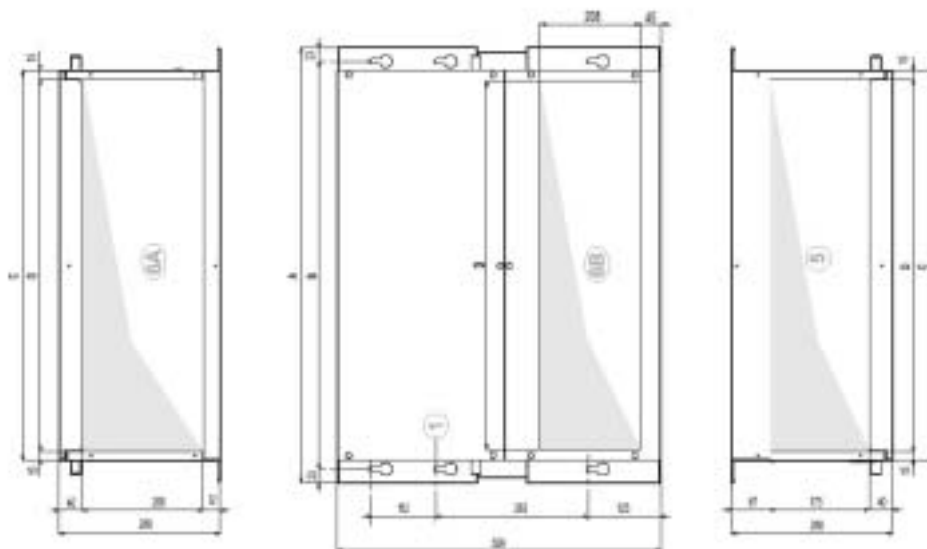
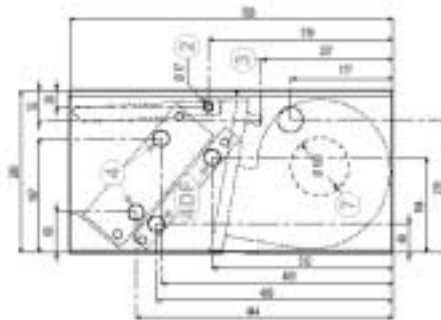

Legend

- 1 6 fast-coupling slots
- 2 Condensate drainage for horizontal installation
- 3 Condensate drainage for vertical installation
- 4 Hydraulic connections
4 = standard heat exchanger
4 DF = supplementary heat exchanger
- 5 Air delivery
- 6 Air intake
6A = supply terms
6B = changeable during installation
- 7 Round pre-sheared element (ϕ 100 mm) for fresh air intake

Hydraulic connections

Standard and additional heat exchanger: connection Male

FWD04	FWD06	FWD08	FWD10	FWD12	FWD16	FWD18
3/4"	3/4"	3/4"	3/4"	1"	1"	1"

	A	B	C	D
FWD04	754	707	676	646
FWD06	964	917	886	856
FWD08+10	1174	1127	1096	1066

4TW60224-1A (Sheet 1/2)

7 Dimensional drawing & centre of gravity

7 - 1 Dimensional drawing

FWD12-16-18

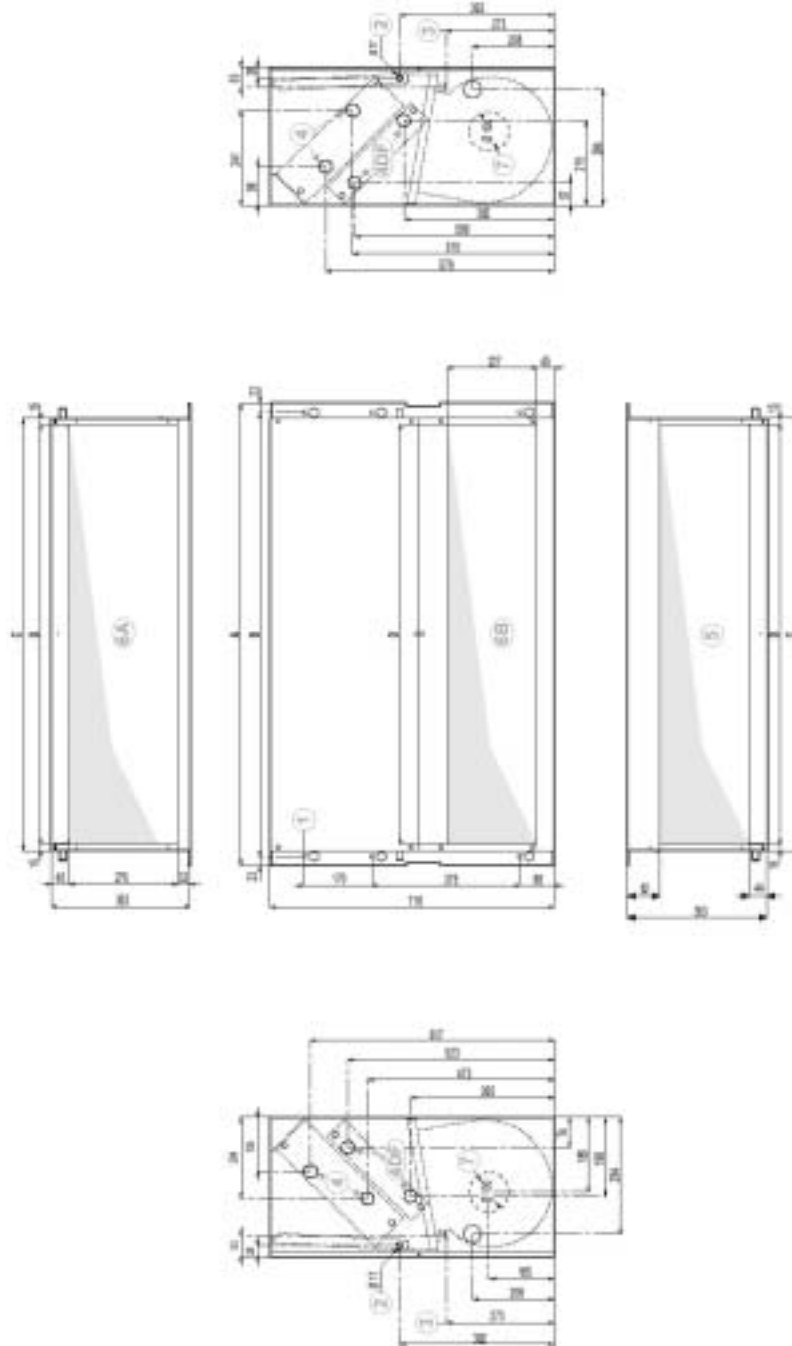

Hydraulic connections

Standard and additional heat exchanger: connection Male

FWD04	FWD06	FWD08	FWD10	FWD12	FWD16	FWD18
3/4"	3/4"	3/4"	3/4"	1"	1"	1"

Legend

- 1 6 fast-coupling slots
- 2 Condensate drainage for horizontal installation
- 3 Condensate drainage for vertical installation
- 4 Hydraulic connections
4 = standard heat exchanger
4 DF = supplementary heat exchanger
- 5 Air delivery
- 6 Air intake
6A = supply terms
6B = changeable during installation
- 7 Round pre-sheared element (φ 100 mm) for fresh air intake

	A	B	C	D
FWD12	1174	1127	1096	1066
FWD16+18	1384	1337	1306	1276

4TW60224-1A (Sheet 2/2)

8 Wiring diagram

8 - 1 Wiring diagram

SYMBOLS

BK	Black = maximum speed
BU	Blue = medium speed
GNYE	Yellow/Green = earth connection
RD	Red = minimum speed
WH	White = common
----	Field wiring
F	Protection fuse (field supply)
IL	Main switch (field supply)
M	Fan motor
PE	Earth connection

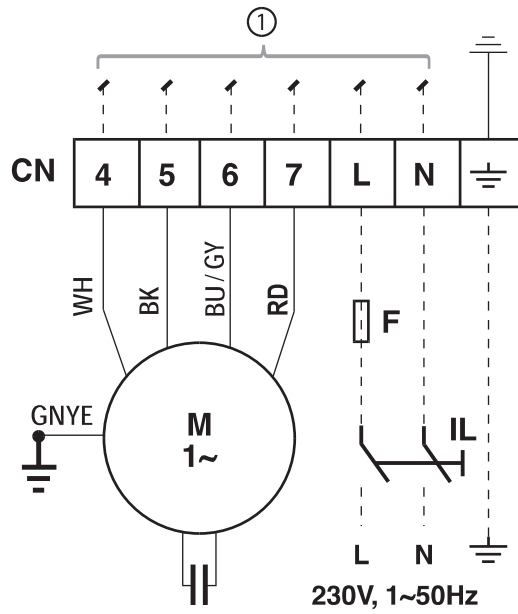

4TW60226-1

9 Sound data

9 - 1 Sound level data - 2-pipe / 4-pipe

FWD04		125 Hz	250 Hz	500 Hz	1000 Hz	2000 Hz	4000 Hz	8000 Hz	Global Lw
Max.	L _w tot dB(A)	43.6	47.0	60.0	62.0	60.7	54.8	46.2	66
		125 Hz	250 Hz	500 Hz	1000 Hz	2000 Hz	4000 Hz	8000 Hz	
	Outlet	40.4	43.3	55.9	58.4	57.0	51.4	42.9	62.5
	Structure	29.3	38.5	53.6	53.0	52.1	43.8	34.3	58.0
	Inlet	40.4	43.3	55.9	58.4	57.0	51.4	42.9	62.5
Med.	L _w tot dB(A)	40.7	53.8	53.8	57.0	53.6	50.6	43.3	61
		125 Hz	250 Hz	500 Hz	1000 Hz	2000 Hz	4000 Hz	8000 Hz	
	Outlet	37.5	50.2	49.7	53.4	49.9	47.2	40.0	57.7
	Structure	26.4	45.3	47.4	47.9	45.0	39.6	31.5	52.9
	Inlet	37.5	50.2	49.7	53.4	49.9	47.2	40.0	57.7
Min.	L _w tot dB(A)	33.8	47.7	47.0	49.8	47.0	41.9	33.5	54
		125 Hz	250 Hz	500 Hz	1000 Hz	2000 Hz	4000 Hz	8000 Hz	
	Outlet	30.6	44.1	42.9	46.2	43.3	38.6	30.2	50.7
	Structure	19.5	39.2	40.6	40.8	38.4	30.9	21.6	46.0
	Inlet	30.6	44.1	42.9	46.2	43.3	38.6	30.2	50.7

4TW60227-1 (Sheet 1/7)

Sound power levels measured at ESP = 0 Pa

2
9

FWD06		125 Hz	250 Hz	500 Hz	1000 Hz	2000 Hz	4000 Hz	8000 Hz	Global Lw
Max.	L _w tot dB(A)	45.0	56.9	60.8	64.7	63.5	57.7	49.7	69
		125 Hz	250 Hz	500 Hz	1000 Hz	2000 Hz	4000 Hz	8000 Hz	
	Outlet	41.8	53.2	56.7	61.2	59.9	54.4	46.4	65.2
	Structure	30.7	48.3	54.4	55.7	55.0	46.7	37.8	60.3
	Inlet	41.8	53.2	56.7	61.2	59.9	54.4	46.4	65.2
Med.	L _w tot dB(A)	41.5	52.6	56.9	59.0	54.7	50.9	40.5	63
		125 Hz	250 Hz	500 Hz	1000 Hz	2000 Hz	4000 Hz	8000 Hz	
	Outlet	38.3	49.0	52.7	55.4	51.1	47.6	37.2	59.1
	Structure	27.2	44.1	50.4	50.0	46.2	39.9	28.7	54.6
	Inlet	38.3	49.0	52.7	55.4	51.1	47.6	37.2	59.1
Min.	L _w tot dB(A)	37.0	48.8	53.0	54.4	50.0	48.6	33.5	59
		125 Hz	250 Hz	500 Hz	1000 Hz	2000 Hz	4000 Hz	8000 Hz	
	Outlet	33.9	45.1	48.8	50.8	46.3	45.3	30.2	54.9
	Structure	22.8	40.3	46.5	45.3	41.4	37.6	21.6	50.4
	Inlet	33.9	45.1	48.8	50.8	46.3	45.3	30.2	54.9

4TW60227-1 (Sheet 2/7)

Sound power levels measured at ESP = 0 Pa

9 Sound data

9 - 1 Sound level data - 2-pipe / 4-pipe

2
9

FWD08		125 Hz	250 Hz	500 Hz	1000 Hz	2000 Hz	4000 Hz	8000 Hz	Global Lw
Max.	L _w tot dB(A)	50.7	62.1	64.8	68.1	66.5	62.5	56.2	72
		125 Hz	250 Hz	500 Hz	1000 Hz	2000 Hz	4000 Hz	8000 Hz	
	Outlet	47.5	58.4	60.7	64.5	62.8	59.1	52.9	68.9
	Structure	36.4	53.6	58.4	59.1	57.9	51.5	44.3	64.0
	Inlet	47.5	58.4	60.7	64.5	62.8	59.1	52.9	68.9
Med.	L _w tot dB(A)	45.0	57.5	60.1	62.5	58.9	56.4	49.2	67
		125 Hz	250 Hz	500 Hz	1000 Hz	2000 Hz	4000 Hz	8000 Hz	
	Outlet	41.8	53.8	56.0	58.9	55.3	53.0	45.9	63.0
	Structure	30.7	49.0	53.7	53.5	50.4	45.4	37.3	58.4
	Inlet	41.8	53.8	56.0	58.9	55.3	53.0	45.9	63.0
Min.	L _w tot dB(A)	40.5	53.4	55.9	57.5	54.3	50.3	42.4	62
		125 Hz	250 Hz	500 Hz	1000 Hz	2000 Hz	4000 Hz	8000 Hz	
	Outlet	37.4	49.7	51.8	53.9	50.6	46.9	39.1	58.2
	Structure	26.3	44.9	49.5	48.4	45.7	39.3	30.5	53.7
	Inlet	37.4	49.7	51.8	53.9	50.6	46.9	39.1	58.2

4TW60227-1 (Sheet 3/7)

Sound power levels measured at ESP = 0 Pa

FWD10		125 Hz	250 Hz	500 Hz	1000 Hz	2000 Hz	4000 Hz	8000 Hz	Global Lw
Max.	L _w tot dB(A)	50.7	62.1	64.8	68.1	66.5	62.5	56.2	72
		125 Hz	250 Hz	500 Hz	1000 Hz	2000 Hz	4000 Hz	8000 Hz	
	Outlet	47.5	58.4	60.7	64.5	62.8	59.1	52.9	68.9
	Structure	36.4	53.6	58.4	59.1	57.9	51.5	44.3	64.0
	Inlet	47.5	58.4	60.7	64.5	62.8	59.1	52.9	68.9
Med.	L _w tot dB(A)	45.0	57.5	60.1	62.5	58.9	56.4	49.2	67
		125 Hz	250 Hz	500 Hz	1000 Hz	2000 Hz	4000 Hz	8000 Hz	
	Outlet	41.8	53.8	56.0	58.9	55.3	53.0	45.9	63.0
	Structure	30.7	49.0	53.7	53.5	50.4	45.4	37.3	58.4
	Inlet	41.8	53.8	56.0	58.9	55.3	53.0	45.9	63.0
Min.	L _w tot dB(A)	40.5	53.4	55.9	57.5	54.3	50.3	42.4	62
		125 Hz	250 Hz	500 Hz	1000 Hz	2000 Hz	4000 Hz	8000 Hz	
	Outlet	37.4	49.7	51.8	53.9	50.6	46.9	39.1	58.2
	Structure	26.3	44.9	49.5	48.4	45.7	39.3	30.5	53.7
	Inlet	37.4	49.7	51.8	53.9	50.6	46.9	39.1	58.2

4TW60227-1 (Sheet 4/7)

Sound power levels measured at ESP = 0 Pa

9 Sound data

9 - 1 Sound level data - 2-pipe / 4-pipe

FWD12		125 Hz	250 Hz	500 Hz	1000 Hz	2000 Hz	4000 Hz	8000 Hz	Global Lw
Max.	L _w tot dB(A)	52.0	62.5	65.2	70.0	69.2	64.5	58.2	74
		125 Hz	250 Hz	500 Hz	1000 Hz	2000 Hz	4000 Hz	8000 Hz	
	Outlet	48.8	58.8	61.1	66.4	65.5	61.1	54.9	70.7
	Structure	37.7	54.0	58.8	61.0	60.6	53.5	46.3	65.7
	Inlet	48.8	58.8	61.1	66.4	65.5	61.1	54.9	70.7
Med.	L _w tot dB(A)	46.2	57.7	59.9	62.8	60.5	57.1	50.0	67
		125 Hz	250 Hz	500 Hz	1000 Hz	2000 Hz	4000 Hz	8000 Hz	
	Outlet	43.1	54.0	55.8	59.2	56.9	53.8	46.8	63.5
	Structure	32.0	49.2	53.5	53.8	52.0	46.1	38.2	58.8
	Inlet	43.1	54.0	55.8	59.2	56.9	53.8	46.8	63.5
Min.	L _w tot dB(A)	39.3	50.6	54.2	55.9	53.1	47.8	41.5	60
		125 Hz	250 Hz	500 Hz	1000 Hz	2000 Hz	4000 Hz	8000 Hz	
	Outlet	36.1	46.9	50.1	52.4	49.5	44.4	38.2	56.5
	Structure	25.0	42.1	47.8	46.9	44.6	36.8	29.6	52.0
	Inlet	36.1	46.9	50.1	52.4	49.5	44.4	38.2	56.5

4TW60227-1 (Sheet 5/7)

Sound power levels measured at ESP = 0 Pa

FWD16		125 Hz	250 Hz	500 Hz	1000 Hz	2000 Hz	4000 Hz	8000 Hz	Global Lw
Max.	L _w tot dB(A)	61.0	70.5	70.0	72.5	71.1	69.6	63.8	78
		125 Hz	250 Hz	500 Hz	1000 Hz	2000 Hz	4000 Hz	8000 Hz	
	Outlet	57.8	66.8	65.9	68.9	67.4	66.2	60.5	74.5
	Structure	46.7	62.0	63.6	63.5	62.5	58.6	51.9	69.4
	Inlet	57.8	66.8	65.9	68.9	67.4	66.2	60.5	74.5
Med.	L _w tot dB(A)	58.3	65.1	67.1	67.9	65.8	64.2	56.7	73
		125 Hz	250 Hz	500 Hz	1000 Hz	2000 Hz	4000 Hz	8000 Hz	
	Outlet	55.2	61.4	63.0	64.3	62.1	60.8	53.4	69.8
	Structure	44.1	56.5	60.7	58.9	57.2	53.2	44.8	65.0
	Inlet	55.2	61.4	63.0	64.3	62.1	60.8	53.4	69.8
Min.	L _w tot dB(A)	52.1	61.3	62.3	63.8	62.6	60.7	49.1	69
		125 Hz	250 Hz	500 Hz	1000 Hz	2000 Hz	4000 Hz	8000 Hz	
	Outlet	48.9	57.7	58.2	60.3	58.9	57.4	45.8	65.7
	Structure	37.8	52.8	55.9	54.8	54.0	49.7	37.2	60.9
	Inlet	48.9	57.7	58.2	60.3	58.9	57.4	45.8	65.7

4TW60227-1 (Sheet 6/7)

Sound power levels measured at ESP = 0 Pa

9 Sound data

9 - 1 Sound level data - 2-pipe / 4-pipe

FWD18		125 Hz	250 Hz	500 Hz	1000 Hz	2000 Hz	4000 Hz	8000 Hz	Global Lw
Max.	L _w tot dB(A)	61.0	70.5	70.0	72.5	71.1	69.6	63.8	78
		125 Hz	250 Hz	500 Hz	1000 Hz	2000 Hz	4000 Hz	8000 Hz	
	Outlet	57.8	66.8	65.9	68.9	67.4	66.2	60.5	74.5
	Structure	46.7	62.0	63.6	63.5	62.5	58.6	51.9	69.4
	Inlet	57.8	66.8	65.9	68.9	67.4	66.2	60.5	74.5
Med.	L _w tot dB(A)	58.3	65.1	67.1	67.9	65.8	64.2	56.7	73
		125 Hz	250 Hz	500 Hz	1000 Hz	2000 Hz	4000 Hz	8000 Hz	
	Outlet	55.2	61.4	63.0	64.3	62.1	60.8	53.4	69.8
	Structure	44.1	56.5	60.7	58.9	57.2	53.2	44.8	65.0
	Inlet	55.2	61.4	63.0	64.3	62.1	60.8	53.4	69.8
Min.	L _w tot dB(A)	52.1	61.3	62.3	63.8	62.6	60.7	49.1	69
		125 Hz	250 Hz	500 Hz	1000 Hz	2000 Hz	4000 Hz	8000 Hz	
	Outlet	48.9	57.7	58.2	60.3	58.9	57.4	45.8	65.7
	Structure	37.8	52.8	55.9	54.8	54.0	49.7	37.2	60.9
	Inlet	48.9	57.7	58.2	60.3	58.9	57.4	45.8	65.7

4TW60227-1 (Sheet 7/7)

Sound power levels measured at ESP = 0 Pa

10 Installation

10 - 1 Installation method

BEFORE THE INSTALLATION

The equipment is to be installed and serviced exclusively by technical personnel who are qualified for using this type of machine, in compliance with the relevant local and national regulations.

On receiving the equipment, check its state ensuring that it was not damaged during transport. Refer to the associated technical sheets for the installation and use instructions of any accessories.

INTENDED CONDITIONS OF USE AND OPERATING LIMITS

No responsibility is assumed if the equipment is installed by unqualified personnel, if it is used improperly or under inadmissible conditions, if maintenance is not performed as envisaged in this manual or if original spare parts are not used. For the operating limits please refer to the appropriate chapter. Any other use is considered improper.

Keep the equipment inside the packing until it is ready to be installed so that dust will not infiltrate.

Air sucked by the equipment must always be filtered. Use, when possible, the specific accessories.

If not used during the winter, drain the water from the system to prevent damage caused by the formation of ice. If antifreeze solutions are used, check the freezing point.

Do not change the internal wiring or other parts of the equipment.

INSTALLATION WARNING:

On the fan coil unit install a switch (IL) and/or all remote controls in a position out of the reach of persons who are in a bathtub or shower.

The FWD units may be installed either in horizontal or vertical position. Check that the desired installation complies with one of the diagrams shown in the installation manual, in which both possible configurations, M or AB, are suitable to work for heating and cooling.

AA (INTAKE IN LINE - DELIVERY IN LINE)

AB (AIR SUCTION AT 90° - AIR OUTLET IN LINE)

CONFIGURATION of the unit

The units are always supplied in AA configuration, but the air intake position may be changed during the installation.

FIXING the unit

Fix the standard unit to the ceiling or wall using at least 4 of the 6 slots;

For horizontal installations (ceiling-mounting) it is advisable to use M8 threaded bars, screw anchors suitable for the machine's weight, and to arrange for the positioning of the machine using 2 M8 bolts and a washer the diameter of which is suitable for

Before tightening the check nut, adjust the closing of the main nut so that the equipment will slant correctly, i.e. for facilitating the discharging of the condensate.

The correct slant is achieved by tilting the intake downwards as compared to the delivery, until a difference in level of about 10 mm is obtained from one end to the other. Make the hydraulic connections with the heat exchanger and, for cooling operations, with the condensate discharge.

Use one of the two drains of the auxiliary tank, visible on the outside of the unit's side panels and vertical condensate discharge.

For vertical installations (wall-mounting), fix the unit so that water may flow out toward the condensate discharge used. A slant equivalent to a difference in level of about 5 mm is enough between the two side panels. The two condensate discharge tubes of the main tank are located inside the side panels and may be accessed through a membrane type passage that should be perforated for passing the discharge tube through it. It is advisable not to remove the aforesaid passage because it prevents the sharp edge of the hole on the side panel from damaging the condensate discharge tube over time.

To connect the unit to the condensate discharge line, use a flexible rubber tube and fix it to the chosen discharge tube (f 3/8) by means of a metal clamp (use the discharge that is located on the hydraulic attachments side). To assist the draining of the condensate, slant the discharge tube downwards by at least 30 mm/m making sure that its entire route is clear and free from bends or blockages.

A few rules to follow

Carry out the heat exchanger's air exhaust, with pumps stopped, by means of the air valves located adjacent to the attachments of the heat exchanger itself.

10 Installation

10 - 1 Installation method

When implementing a duct system, it is advisable to place the vibration-damping joints between the ducting and the unit. If you wish to install an electrical resistance module as accessory, the delivery vibration-damping joint should be heat-resistant. The ducting, especially the delivery one, should be insulated with anticondensing material.

Provide an inspection panel adjacent to the equipment for the maintenance and cleaning operations.

Install the control panel on the wall. Choose a position that is easy to access for the setting of the functions and, if contemplated, for the reading of the temperature. Try to avoid positions that are directly exposed to sun rays, or positions subject to direct hot or cold air currents, and do not place obstacles in the way that would prevent the correct reading of the temperature.

ELECTRICAL CONNECTIONS

Carry out the electrical wiring after having turned the power off in compliance with the relevant local and national regulations following the relevant wiring diagram.

Only qualified personnel should carry out the wiring operations.

Each fan coil requires a switch (IL) on the feeder line with a distance of at least 3 mm between the opening contacts, and a suitable safety fuse (F).

Power consumption is shown on the data plate fixed to the unit. Make sure to carefully execute the wiring in function of the combination unit/controller and this according to the correct wiring diagram delivered with every accessory. In order to make the electrical connections you must remove the lower closing panel to access the terminal board. The power cables (power supply and control) must be routed to the terminal board through the membrane passage that is on the side panel of the machine on the side opposite the hydraulic attachments.

WARNING

The COMMON wire of the motor is the WHITE one: if connected incorrectly the motor would be damaged irreparably.

FUNCTIONAL CHECKS

Check that the equipment has been installed so that it guarantees the required slant.

Check that the condensate discharge is not clogged (by rubble deposits, etc.).

Check the seal of the hydraulic connections.

Check that all the wirings are tight (perform the check with voltage OFF).

Make sure air has been purged from the heat exchanger.

Power the equipment and check its working efficiency.

10 Installation

10 - 1 Installation method

1. Ducted unit with filter only

Consider at least:

- 500 mm free space on water connections side (piping & connections)
- 200 mm free space on the opposite side (to unscrew heat exchangers or fan deck in case of repairing)
- Possibility to extract filter for cleaning has to be considered
- Possibility to reach the unit for ordinary and extraordinary maintenance (for instance removing front panels) has to be considered

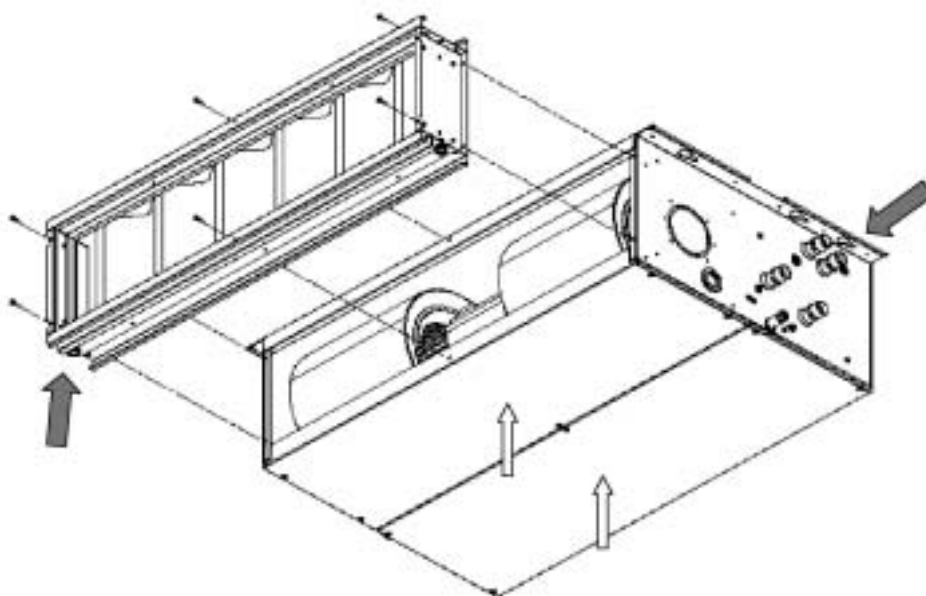

4TW60229-3

10 Installation

10 - 1 Installation method

2. Ducted unit with filter and electric heater

Consider also:

- 500 mm free space on water connections side (piping & connections), measured from the electrical box of the heating module (refer to option technical leaflet for details - total 620 mm)
- 200 mm free space on the opposite side (to unscrew heat exchangers or fan deck in case of repairing)
- Possibility to extract filter for cleaning has to be considered
- Possibility to reach the unit for ordinary and extraordinary maintenance (for instance removing front panels) has to be considered

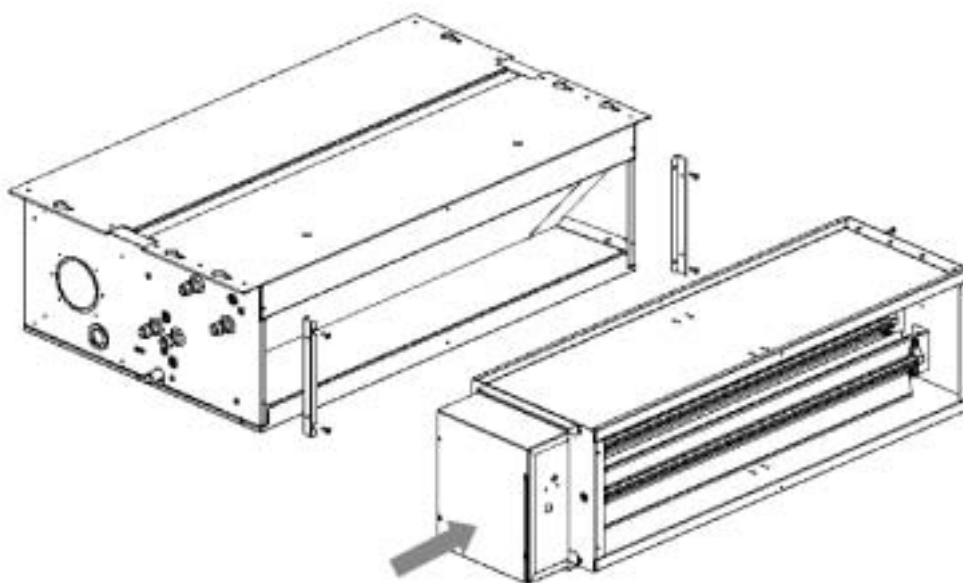

4TW60229-3

10 Installation

10 - 1 Installation method

3. Ducted unit with filter and valves

Consider also:

- 500 mm free space on water connections side (piping & connections), measured from the valve piping (refer to option technical leaflet for details - total around 720 mm)
- 200 mm free space on the opposite side (to unscrew heat exchangers or fan deck in case of repairing)
- Possibility to extract filter for cleaning has to be considered
- Possibility to reach the unit for ordinary and extraordinary maintenance (for instance removing front panels) has to be considered

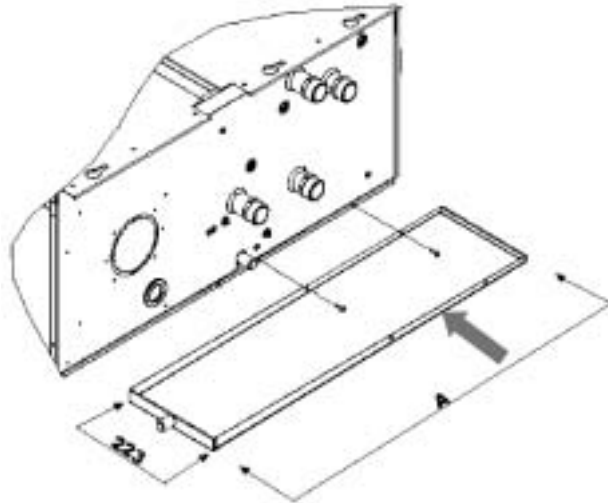

4TW60229-3

11 Operation range

Minimum water temperature	+5°C
Maximum water temperature	+95°C
Maximum operating pressure	10 bar
Minimum air inlet temperature	-20°C
Maximum air inlet temperature	+43°C
Power supply	230V +-10% / 1~ / 50Hz

4TW60223-1

12 Hydraulic performance

12 - 2 Water pressure drop curve evaporator heating 2-pipe

FWD							
Water flow l/h	Water pressure drop						
	FWD04	FWD06	FWD08	FWD10	FWD12	FWD16	FWD18
	kPa	kPa	kPa	kPa	kPa	kPa	kPa
100	0.59	0.37	0.25	0.13	0.13	0.09	0.1
200	2.02	1.25	0.84	0.45	0.43	0.32	0.35
300	4.12	2.57	1.72	0.92	0.88	0.65	0.71
400	6.83	4.27	2.86	1.53	1.47	1.08	1.19
500	10.12	6.32	4.24	2.27	2.19	1.6	1.76
600	13.94	8.71	5.85	3.14	3.02	2.22	2.44
700	18.28	11.42	7.67	4.12	3.97	2.92	3.2
800	23.12	14.45	9.69	5.21	5.02	3.69	4.06
900	28.45	17.77	11.92	6.41	6.17	4.55	5
1000	34.23	21.39	14.35	7.71	7.43	5.48	6.02
1100	40.48	25.29	16.97	9.11	8.79	6.47	7.11
1200	47.17	29.48	19.78	10.62	10.24	7.54	8.29
1300	54.29	33.94	22.77	12.23	11.78	8.68	9.54
1400	61.84	38.66	25.94	13.93	13.42	9.89	10.87
1500	69.81	43.65	29.28	15.73	15.16	11.16	12.27
1600	78.19	48.9	32.8	17.62	16.98	12.5	13.75
1700	86.97	54.4	36.5	19.6	18.89	13.91	15.3
1800	96.15	60.15	40.36	21.67	20.89	15.38	16.92
1900	105.73	66.15	44.38	23.83	22.97	16.92	18.61
2000	-	72.39	48.57	26.08	25.14	18.52	20.37
2100	-	78.88	52.93	28.42	27.4	20.18	22.19
2200	-	85.6	57.44	30.84	29.73	21.9	24.09
2300	-	92.55	62.11	33.35	32.15	23.68	26.05
2400	-	99.74	66.93	35.94	34.65	25.53	28.08
2500	-	107.16	71.91	38.62	37.23	27.43	30.17
3000	-	-	99.07	53.21	51.3	37.8	41.59
4000	-	-	-	88.2	85.07	62.71	69
5000	-	-	-	-	-	92.83	102.16

4TW60229-1 (Sheet 1/3)

2
12

12-2 Water pressure drop curve evaporator heating 2-pipe

FWD							
Water flow l/h	Water pressure drop						
	FWD04	FWD06	FWD08	FWD10	FWD12	FWD16	FWD18
	kPa	kPa	kPa	kPa	kPa	kPa	kPa
100	0.51	0.32	0.22	0.12	0.11	0.08	0.09
200	1.68	1.07	0.72	0.39	0.38	0.28	0.31
300	3.4	2.16	1.46	0.78	0.76	0.56	0.62
400	5.6	3.56	2.4	1.29	1.25	0.93	1.03
500	8.25	5.24	3.53	1.9	1.84	1.37	1.51
600	11.33	7.18	4.84	2.61	2.53	1.88	2.07
700	14.81	9.39	6.32	3.4	3.3	2.45	2.71
800	18.69	11.83	7.97	4.29	4.16	3.09	3.41
900	22.95	14.52	9.77	5.26	5.1	3.79	4.18
1000	27.57	17.43	11.73	6.32	6.12	4.55	5.02
1100	32.55	20.57	13.85	7.46	7.22	5.36	5.91
1200	37.89	23.94	16.11	8.67	8.4	6.23	6.88
1300	43.56	27.51	18.51	9.97	9.65	7.14	7.9
1400	49.58	31.3	21.06	11.34	10.97	8.14	8.98
1500	55.92	35.29	23.74	12.78	12.37	9.17	10.12
1600	62.58	39.49	26.57	14.3	13.84	10.26	11.32
1700	69.57	43.89	29.52	15.89	15.37	11.4	12.57
1800	76.87	48.49	32.61	17.55	16.98	12.59	13.88
1900	84.48	53.28	35.83	19.28	18.65	13.83	15.24
2000	92.4	58.26	39.18	21.09	20.39	15.12	16.66
2100	100.61	63.43	42.66	22.95	22.2	16.45	18.14
2200	109.13	68.79	46.26	24.89	24.07	17.84	19.66
2300	-	74.34	49.99	26.9	26.01	19.27	21.24
2400	-	80.07	53.84	28.97	28.01	20.75	22.87
2500	-	85.97	57.81	31.1	30.08	22.28	24.55
3000	-	118.18	79.46	42.74	41.32	30.59	33.71
4000	-	-	-	70.61	68.24	50.5	55.63
5000	-	-	-	104.24	100.72	74.51	82.08

4TW60229-1 (Sheet 2/3)

12 Hydraulic performance

12 - 3 Water pressure drop curve evaporator heating 4-pipe

FWD							
Water flow l/h	Water pressure drop						
	FWD04	FWD06	FWD08	FWD10	FWD12	FWD16	FWD18
	kPa	kPa	kPa	kPa	kPa	kPa	kPa
100	0.83	0.71	0.35	0.35	0.13	0.1	0.1
200	2.75	2.36	1.16	1.16	0.42	0.33	0.33
300	5.55	4.76	2.34	2.34	0.85	0.67	0.67
400	9.14	7.84	3.84	3.84	1.39	1.1	1.1
500	13.48	11.54	5.65	5.65	2.05	1.61	1.61
600	18.51	15.83	7.75	7.75	2.81	2.21	2.21
700	24.21	20.7	10.13	10.13	3.66	2.88	2.88
800	30.56	26.1	12.77	12.77	4.62	3.63	3.63
900	37.52	32.04	15.68	15.68	5.66	4.45	4.45
1000	45.09	38.49	18.83	18.83	6.8	5.34	5.34
1100	53.25	45.44	22.22	22.22	8.02	6.29	6.29
1200	61.98	52.88	25.85	25.85	9.33	7.32	7.32
1300	71.27	60.8	29.72	29.72	10.72	8.41	8.41
1400	81.11	69.18	33.81	33.81	12.19	9.56	9.56
1500	91.5	78.03	38.13	38.13	13.74	10.78	10.78
1600	102.41	87.32	42.67	42.67	15.37	12.06	12.06
1700	-	97.06	47.42	47.42	17.08	13.39	13.39
1800	-	107.24	52.39	52.39	18.87	14.79	14.79
1900	-	-	57.57	57.57	20.73	16.25	16.25
2000	-	-	62.96	62.96	22.67	17.76	17.76
2500	-	-	92.92	92.92	33.44	26.19	26.19
3000	-	-	-	-	45.95	35.98	35.98
3500	-	-	-	-	60.12	47.06	47.06
4000	-	-	-	-	75.89	59.4	59.4
4500	-	-	-	-	93.21	72.95	72.95
5000	-	-	-	-	112.04	87.67	87.67

4TW60229-1 (Sheet 3/3)

TABLE OF CONTENTS

FWB

1	Features	81
2	Specifications	82
	Nominal capacity and nominal input	82
	Technical Specifications	83
	Electrical Specifications	86
3	Electrical data	87
4	Options	88
5	Capacity tables	89
	Cooling capacity tables - 2-pipe	89
	Capacity tables with glycol for process cooling applications	91
	Heating capacity tables - 2-pipe	92
	Heating capacity tables additional heat exchanger	94
	Power consumption	96
	Capacity correction factor	98
6	Dimensional drawing & centre of gravity	99
	Dimensional drawing	99
7	Wiring diagram	100
	Wiring diagram	100
8	Sound data	101
	Sound power spectrum - 2-pipe	101
9	Installation	104
	Installation method	104
10	Operation range	106
11	Water pressure drop curve evaporator	107
	Water pressure drop curve evaporator cooling 2-pipe	107
	Water pressure drop curve evaporator heating 2-pipe	107
	Water pressure drop curve evaporator additional heat exchanger	108

1 Features

- Height of the units only 240mm for all the sizes
- 3, 4 or 6 stage row cooling coil
- Drain pan to collect the condensate from: heat exchanger and regulating valves
- 7-speed electrical motors (with thermal protection on windings)
- All 7 speeds pre-wired in the factory in the terminal block of the switch box
- Standard air filter : removable from the bottom



3

1

2 Specifications

2-1 NOMINAL CAPACITY AND NOMINAL INPUT			FWB02AT	FWB03AT	FWB04AT	
Power Input	High	W	106	106	106	
	Medium	W	56	56	56	
	Low	W	34	34	34	
Cooling capacity	Total capacity	High	kW	2.61	3.14	3.49
		Medium	kW	2.01	2.42	2.64
		Low	kW	1.34	1.50	1.67
	Sensible capacity	High	kW	1.88	2.16	2.34
		Medium	kW	1.46	1.66	1.77
		Low	kW	0.95	1.02	1.10
Heating capacity (2-pipe)	High	kW	5.47	6.01	6.47	
	Medium	kW	4.32	4.66	4.93	
	Low	kW	2.77	2.91	3.00	
Heating capacity (4-pipe)	High	kW	3.14	3.14	3.14	
	Medium	kW	2.68	2.68	2.68	
	Low	kW	1.95	1.95	1.95	

2-1 NOMINAL CAPACITY AND NOMINAL INPUT			FWB05AT	FWB06AT	FWB07AT	
Power Input	High	W	192	192	192	
	Medium	W	143	143	143	
	Low	W	76	76	76	
Cooling capacity	Total capacity	High	kW	5.08	5.45	6.47
		Medium	kW	3.99	4.12	4.96
		Low	kW	2.12	2.43	2.67
	Sensible capacity	High	kW	3.60	3.87	4.40
		Medium	kW	2.84	2.96	3.37
		Low	kW	1.52	1.67	1.78
Heating capacity (2-pipe)	High	kW	10.31	11.39	12.28	
	Medium	kW	8.20	8.92	9.48	
	Low	kW	4.56	4.77	4.94	
Heating capacity (4-pipe)	High	kW	5.99	5.99	5.99	
	Medium	kW	5.14	5.14	5.14	
	Low	kW	3.38	3.38	3.38	

2-1 NOMINAL CAPACITY AND NOMINAL INPUT			FWB08AT	FWB09AT	FWB10AT	
Power Input	High	W	294	294	294	
	Medium	W	193	193	193	
	Low	W	155	155	155	
Cooling capacity	Total capacity	High	kW	7.57	8.67	10.34
		Medium	kW	5.41	6.08	7.08
		Low	kW	4.18	4.64	5.35
	Sensible capacity	High	kW	5.23	5.96	6.90
		Medium	kW	3.78	4.20	4.72
		Low	kW	2.95	3.21	3.57
Heating capacity (2-pipe)	High	kW	15.05	16.85	18.78	
	Medium	kW	10.94	11.97	12.93	
	Low	kW	8.63	9.29	9.85	
Heating capacity (4-pipe)	High	kW	12.80	12.80	12.80	
	Medium	kW	9.55	9.55	9.55	
	Low	kW	7.67	7.67	7.67	

2 Specifications

2-2 TECHNICAL SPECIFICATIONS				FWB02AT	FWB03AT	FWB04AT
Dimensions	Unit	Height	mm	239	239	239
		Width	mm	1039	1039	1039
		Depth	mm	609	609	609
	Unit with packing	Height	mm	305	305	305
		Width	mm	1100	1100	1100
Depth		mm	650	650	650	
Weight	Machine weight		kg	23	24	26
	Operation weight		kg	24	26	28
	Gross weight		kg	26	27	29
Material				Galvanised sheet metal		
Sound level	Sound pressure	High	dBA	46.5	46.5	46.5
		Medium	dBA	34.5	34.5	34.5
		Low	dBA	24.5	24.5	24.5
	Sound power	High	dBA	58	58	58
		Medium	dBA	46	46	46
Low		dBA	36	36	36	
Water flow	Cooling		l/h	448	539	598
	Heating		l/h	480	527	567
	Add. heat exchanger		l/h	275	275	275
Water pressure drop	Cooling		kPa	8	14	11
	Heating		kPa	7	10	8
	Add. heat exchanger		kPa	3	3	3
Fan	Type			Centrifugal - forward blades - directly coupled on fan		
	Air flow rate	High	m³/h	400	400	400
		Medium	m³/h	300	300	300
		Low	m³/h	180	180	180
	Available pressure	High	Pa	71	71	71
		Medium	Pa	29	29	29
		Low	Pa	20	20	20
Speed			7 speeds (high = 7, medium = 4, low = 1)			
Quantity			1	1	1	
Motor				Closed induction, B class insulation, winding thermal cut-out		
Standard heat exchanger	Rows		mm	3	4	6
	Stages		mm	3	3	4
	Fin pitch		mm	2.1	2.1	2.1
	Face area		m²	0.15	0.15	0.15
	Water volume		l	1.1	1.5	2.2
Additional heat exchanger	Rows		mm	1	1	1
	Stages		mm	2	2	2
	Fin pitch		mm	1.8	1.8	1.8
	Face area		m²	0.14	0.14	0.14
	Water volume		l	0.4	0.4	0.4
Air filter				Standard filter class EU2		
Insulation material				Class 1 self-extinguishing		
Vibration insulation				Rubber ring for fan motor		
Water connections	Std. heat exchanger		inch	3/4		
	Add. heat exchanger		inch	3/4		
Drain			mm	16	16	16
Notes				Rating conditions cooling 2 pipe: air 27		
				Rating conditions heating 2 pipe: air 20°CDB - entering water 70°C - leaving water 60°C		
				Sound power level according to ISO3741 - sound pressure calculated at 1.5m distance - Q = 2		

2 Specifications

2-2 TECHNICAL SPECIFICATIONS				FWB05AT	FWB06AT	FWB07AT
Dimensions	Unit	Height	mm	239	239	239
		Width	mm	1389	1389	1389
		Depth	mm	609	609	609
	Unit with packing	Height	mm	305	305	305
		Width	mm	1450	1450	1450
		Depth	mm	650	650	650
Weight	Machine weight		kg	31	33	35
	Operation weight		kg	33	35	38
	Gross weight		kg	35	37	39
Material				Galvanised sheet metal		
Sound level	Sound pressure	High	dBA	48.5	48.5	48.5
		Medium	dBA	40.5	40.5	40.5
		Low	dBA	25.5	25.5	25.5
	Sound power	High	dBA	60	60	60
		Medium	dBA	52	52	52
		Low	dBA	37	37	37
Water flow	Cooling		l/h	873	936	1111
	Heating		l/h	904	999	1077
	Add. heat exchanger		l/h	526	526	526
Water pressure drop	Cooling		kPa	15	8	14
	Heating		kPa	12	7	10
	Add. heat exchanger		kPa	5	5	5
Fan	Type			Centrifugal - forward blades - directly coupled on fan		
	Air flow rate	High	m³/h	800	800	800
		Medium	m³/h	600	600	600
		Low	m³/h	300	300	300
	Available pressure	High	Pa	65	65	65
		Medium	Pa	44	44	44
		Low	Pa	23	23	23
Speed			7 speeds (high = 7, medium = 4, low = 1)			
Quantity			2	2	2	
Motor				Closed induction, B class insulation, winding thermal cut-out		
Standard heat exchanger	Rows	mm	3	4	6	
	Stages	mm	4	6	6	
	Fin pitch	mm	2.1	2.1	2.5	
	Face area	m²	0.22	0.22	0.22	
	Water volume	l	1.6	2.1	3.2	
Additional heat exchanger	Rows	mm	1	1	1	
	Stages	mm	3	3	3	
	Fin pitch	mm	1.8	1.8	1.8	
	Face area	m²	0.24	0.24	0.24	
	Water volume	l	0.6	0.6	0.6	
Air filter				Standard filter class EU2		
Insulation material				Class 1 self-extinguishing		
Vibration insulation				Rubber ring for fan motor		
Water connections	Std. heat exchanger		inch	3/4		
	Add. heat exchanger		inch	3/4		
Drain			mm	16	16	16
Notes				Rating conditions cooling 2 pipe: air 27		
				Rating conditions heating 2 pipe: air 20°CDB - entering water 70°C - leaving water 60°C		
				Sound power level according to ISO3741 - sound pressure calculated at 1.5m distance - Q = 2		

2 Specifications

2-2 TECHNICAL SPECIFICATIONS				FWB08AT	FWB09AT	FWB10AT
Dimensions	Unit	Height	mm	239	239	239
		Width	mm	1739	1739	1739
		Depth	mm	609	609	609
	Unit with packing	Height	mm	305	305	305
		Width	mm	1800	1800	1800
Depth		mm	650	650	650	
Weight	Machine weight		kg	43	45	48
	Operation weight		kg	45	48	52
	Gross weight		kg	47	50	54
Material				Galvanised sheet metal		
Sound level	Sound pressure	High	dBA	57.5	57.5	57.5
		Medium	dBA	46.5	46.5	46.5
		Low	dBA	41.5	41.5	41.5
	Sound power	High	dBA	69	69	69
		Medium	dBA	58	58	58
Low		dBA	53	53	53	
Water flow	Cooling		l/h	1299	1488	1774
	Heating		l/h	1319	1479	1647
	Add. heat exchanger		l/h	1123	1123	1123
Water pressure drop	Cooling		kPa	21	21	26
	Heating		kPa	16	15	18
	Add. heat exchanger		kPa	8	8	8
Fan	Type			Centrifugal - forward blades - directly coupled on fan		
	Air flow rate	High	m³/h	1200	1200	1200
		Medium	m³/h	800	800	800
		Low	m³/h	600	600	600
	Available pressure	High	Pa	59	59	59
		Medium	Pa	43	43	43
		Low	Pa	29	29	29
Speed			7 speeds (high = 7, medium = 4, low = 1)			
Quantity			3	3	3	
Motor				Closed induction, B class insulation, winding thermal cut-out		
Standard heat exchanger	Rows		mm	3	4	6
	Stages		mm	5	6	6
	Fin pitch		mm	2.1	2.1	2.1
	Face area		m²	0.29	0.29	0.29
	Water volume		l	2.1	2.8	4.2
Additional heat exchanger	Rows		mm	2	2	2
	Stages		mm	6	6	6
	Fin pitch		mm	2.1	2.1	2.1
	Face area		m²	0.35	0.35	0.35
	Water volume		l	1.7	1.7	1.7
Air filter				Standard filter class EU2		
Insulation material				Class 1 self-extinguishing		
Vibration insulation				Rubber ring for fan motor		
Water connections	Std. heat exchanger		inch	3/4		
	Add. heat exchanger		inch	1	1	1
Drain			mm	16	16	16
Notes				Rating conditions cooling 2 pipe: air 27		
				Rating conditions heating 2 pipe: air 20°CDB - entering water 70°C - leaving water 60°C		
				Sound power level according to ISO3741 - sound pressure calculated at 1.5m distance - Q = 2		

3

2

2 Specifications

2-3 ELECTRICAL SPECIFICATIONS			FWB02AT	FWB03AT	FWB04AT
Current input	High	A	0.51	0.51	0.51
	Medium	A	0.30	0.30	0.30
	Low	A	0.20	0.20	0.20
Required power supply		V / f / Hz	230/1/50		
Required fuses		A	1	1	1
Required wire section		mm ²	1.5	1.5	1.5
Electric heater	Power input	kW	2	2	2
	Current	A	8.7	8.7	8.7
	Power supply	V / f / Hz	230/1/50		
Notes		The power consumption for the valve motor is 5W (peak) only during opening			
		For more details concerning conditional connections, see http://www.daikineurope.com , select E-data Books. Finally click on the document title of your choice			

2-3 ELECTRICAL SPECIFICATIONS			FWB05AT	FWB06AT	FWB07AT
Current input	High	A	0.94	0.94	0.94
	Medium	A	0.70	0.70	0.70
	Low	A	0.40	0.40	0.40
Required power supply		V / f / Hz	230/1/50		
Required fuses		A	2	2	2
Required wire section		mm ²	1.5	1.5	1.5
Electric heater	Power input	kW	2.5	2.5	2.5
	Current	A	10.9	10.9	10.9
	Power supply	V / f / Hz	230/1/50		
Notes		The power consumption for the valve motor is 5W (peak) only during opening			
		For more details concerning conditional connections, see http://www.daikineurope.com , select E-data Books. Finally click on the document title of your choice			

2-3 ELECTRICAL SPECIFICATIONS			FWB08AT	FWB09AT	FWB10AT
Current input	High	A	1.28	1.28	1.28
	Medium	A	0.90	0.90	0.90
	Low	A	0.70	0.70	0.70
Required power supply		V / f / Hz	230/1/50		
Required fuses		A	2	2	2
Required wire section		mm ²	1.5	1.5	1.5
Electric heater	Power input	kW	3	3	3
	Current	A	13	13	13
	Power supply	V / f / Hz	230/1/50		
Notes		The power consumption for the valve motor is 5W (peak) only during opening			
		For more details concerning conditional connections, see http://www.daikineurope.com , select E-data Books. Finally click on the document title of your choice			

3 Electrical data

FWB		Power input electric heater	Current Absorption	Power supply
Unit	Electric heater	kW	A	V / f / Hz
FWB02AT		2.0	8.7	230 - 1 - 50
FWB03AT		2.0	8.7	
FWB04AT		2.0	8.7	
FWB05AT		2.5	10.9	
FWB06AT		2.5	10.9	
FWB07AT		2.5	10.9	
FWB08AT		3.0	13.0	
FWB09AT		3.0	13.0	
FWB10AT		3.0	13.0	

4TW60298-1

3

3

4 Options

FWB	02	03	04	05	06	07	08	09	10	Comments	
Additional heat exchanger	EAH04A6			EAH07A6			EAH10A6				
3-way valve cooling h/e	Factory mounted										
capacity limitation	E2MV307A6					E2MV310A6					
2-way valve cooling h/e	Factory mounted										
2-way valve add. h/e	E2MV207A6					E2MC210A6					
Electric heater	Factory mounted										
Fan stop thermostat	YFSTA6										
Power interface	-					EPIA6					*
Master / Slave Interface	EPIMSA6										
Controller electronic - remote	ECFWER6										

* In combination with ECFWER6, EPIA6 or EPIMSA6 must be installed for FWB 08-10

4TW60299-2A (Sheet 1/2)

3
4

FWB		Additional heat exchanger	3-way valve add. h/e	2-way valve add. h/e	Fan stop thermostat	Power interface	Master / Slave Interface	Controller electronic - remote
		EAH.A6	E2MV3.A6	E2MV2.A6	YFSTA6	EPIA6	EPIMSA6	ECFWER6
Additional heat exchanger	EAH.A6		X	X	X *	X	X	X
3-way valve add. h/e	E2MV3.A6	X				X	X	X
2-way valve add. h/e	E2MV2.A6	X				X	X	
Fan stop thermostat	YFSTA6					X *	X *	
Power interface	EPIA6	X	X	X	X *			X
Master / Slave Interface	EPIMSA6	X	X					X
Controller electronic - remote	ECFWER6	X	X			X	X	

* = FWB used for heating only

4TW60299-2A (Sheet 2/2)

5 Capacity tables

5 - 1 Cooling capacity tables - 2-pipe

3

5

Air temperature (°C DB - °C WB) Water temperature (Entering °C - leaving °C)		25 - 18						9 - 14					
		6 - 11			7 - 12			8 - 13			9 - 14		
Model	Air flow m ³ /h	Total cooling capacity W	Sensible cooling capacity W	Water flow ℓ/h	Water pressure drop kPa	Total cooling capacity W	Sensible cooling capacity W	Water flow ℓ/h	Water pressure drop kPa	Total cooling capacity W	Sensible cooling capacity W	Water flow ℓ/h	Water pressure drop kPa
FWB02	300	1900	1350	326	4	1590	1230	273	3	1410	1150	242	3
	400	2490	1750	427	7	2130	1610	366	5	1710	1440	294	4
	500	3020	2120	517	10	2610	1960	448	8	2150	1770	368	5
	300	2320	1560	398	8	2060	1440	353	6	1760	1320	302	5
	400	3020	2030	518	13	2690	1890	461	10	2320	1730	398	8
FWB03	500	3670	2470	630	18	3270	2300	561	15	2880	2120	487	11
	300	2540	1670	436	6	2270	1550	390	5	2000	1430	344	4
	400	3360	2210	576	10	3020	2060	518	8	2640	1890	453	7
	500	4140	2740	710	15	3730	2550	639	12	3270	2350	561	10
	600	3810	2650	653	9	3300	2440	566	7	2700	2210	464	5
FWB05	800	4870	3370	834	14	4250	3120	729	11	3560	2850	611	8
	1000	5830	4020	1000	19	5100	3730	875	15	4300	3420	739	11
	600	3870	2740	663	4	3280	2500	562	3	2910	2350	499	3
	800	5180	3610	889	7	4410	3290	757	5	3360	2870	577	3
	1000	6360	4380	1091	10	5480	4020	940	8	4450	3610	763	5
FWB06	600	4770	3180	817	8	4230	2940	727	7	3620	2680	622	5
	800	6230	4150	1069	13	5560	3860	955	11	4830	3550	829	9
	1000	7600	5070	1304	19	6800	4720	1167	16	5920	4350	1017	12
	1000	6250	4250	1072	15	5470	3930	939	12	4600	3590	790	9
	1200	7260	4910	1245	19	6370	4550	1093	15	5390	4160	926	11
FWB07	1400	8200	5510	1406	24	7210	5110	1237	19	6130	4690	1052	14
	1000	7120	4800	1220	15	6290	4450	1080	12	5380	4080	923	9
	1200	8330	5610	1428	19	7380	5210	1267	16	6340	4780	1089	12
	1400	9480	6370	1626	24	8410	5920	1443	19	7240	5440	1244	15
	1000	8430	5530	1446	19	7610	5150	1306	15	6710	4760	1153	12
FWB08	1200	9970	6540	1711	25	9010	6100	1546	21	7960	5640	1367	17
	1400	11470	7510	1967	32	10360	7010	1778	26	9160	6490	1572	21
	1000	8430	5530	1446	19	7610	5150	1306	15	6710	4760	1153	12
	1200	9970	6540	1711	25	9010	6100	1546	21	7960	5640	1367	17
	1400	11470	7510	1967	32	10360	7010	1778	26	9160	6490	1572	21
FWB09	1000	8430	5530	1446	19	7610	5150	1306	15	6710	4760	1153	12
	1200	9970	6540	1711	25	9010	6100	1546	21	7960	5640	1367	17
	1400	11470	7510	1967	32	10360	7010	1778	26	9160	6490	1572	21
	1000	8430	5530	1446	19	7610	5150	1306	15	6710	4760	1153	12
	1200	9970	6540	1711	25	9010	6100	1546	21	7960	5640	1367	17
FWB10	1400	11470	7510	1967	32	10360	7010	1778	26	9160	6490	1572	21
	1000	8430	5530	1446	19	7610	5150	1306	15	6710	4760	1153	12
	1200	9970	6540	1711	25	9010	6100	1546	21	7960	5640	1367	17
	1400	11470	7510	1967	32	10360	7010	1778	26	9160	6490	1572	21
	1000	8430	5530	1446	19	7610	5150	1306	15	6710	4760	1153	12

4TW60292-1 (Sheet 1/6)

5 Capacity tables

5 - 1 Cooling capacity tables - 2-pipe

Air temperature (°C DB - °C WB) Water temperature (Entering °C - leaving °C)		27 - 19																						
		6 - 11				7 - 12				8 - 13				9 - 14										
Model	Air flow m ³ /h	Total cooling capacity		Water pressure drop		Water flow		Sensible cooling capacity		Water pressure drop		Water flow		Sensible cooling capacity		Water pressure drop		Water flow		Sensible cooling capacity				
		W	W	kPa	kPa	ℓ/h	ℓ/h	W	W	kPa	kPa	ℓ/h	ℓ/h	W	W	kPa	kPa	ℓ/h	ℓ/h	W	W	kPa	kPa	
FWB02	300	2260	1560	6	388	2010	1460	5	1710	1340	298	4	1440	1230	247	3								
	400	2920	2010	9	501	2610	1880	8	2250	1740	386	6	1840	1580	315	4								
	500	3530	2430	13	605	3160	2270	11	2740	2110	470	8	2270	1930	390	6								
	600	4190	2790	16	719	3790	2630	14	3300	2450	568	11	2820	2300	466	8								
FWB03	300	2660	1760	10	456	2420	1660	9	2150	1540	369	7	1840	1420	317	5								
	400	3450	2290	16	591	3140	2160	14	2790	2010	479	11	2420	1860	416	8								
	500	4190	2790	23	719	3820	2630	19	3400	2450	588	15	2950	2270	507	12								
	600	4880	3200	31	868	4510	3140	26	4100	3000	707	20	3600	2750	607	16								
FWB04	300	2880	1880	8	494	2640	1770	7	2370	1650	407	6	2050	1520	353	4								
	400	3790	2490	13	651	3490	2340	11	3130	2190	538	9	2750	2030	472	7								
	500	4680	3070	18	802	4290	2890	16	3860	2700	663	13	3400	2510	584	10								
	600	5570	3640	25	972	5080	3600	22	4660	3350	815	18	4200	3200	707	14								
FWB05	600	4680	3200	6	804	4120	2960	5	3420	2680	587	3	2970	2510	510	3								
	800	6130	4150	9	1053	5450	3870	8	4690	3560	805	6	3750	3200	644	4								
	1000	7470	5020	13	1282	6670	4680	11	5780	4330	993	8	4770	3940	820	6								
	1200	8660	5700	19	1486	7900	5370	16	6770	5020	1215	17	6190	4660	1063	13								
FWB06	600	4680	3200	6	804	4120	2960	5	3420	2680	587	3	2970	2510	510	3								
	800	6130	4150	9	1053	5450	3870	8	4690	3560	805	6	3750	3200	644	4								
	1000	7470	5020	13	1282	6670	4680	11	5780	4330	993	8	4770	3940	820	6								
	1200	8660	5700	19	1486	7900	5370	16	6770	5020	1215	17	6190	4660	1063	13								
FWB07	600	5450	3590	11	935	4960	3370	9	4430	3140	760	7	3830	2890	657	6								
	800	7100	4680	17	1218	6470	4400	14	5800	4110	995	12	5060	3810	868	9								
	1000	8660	5700	24	1486	7900	5370	20	7080	5020	1215	17	6190	4660	1063	13								
	1200	10000	6840	31	1800	9200	6300	27	8300	6000	1515	24	7400	5500	1315	17								
FWB08	600	4680	3200	6	804	4120	2960	5	3420	2680	587	3	2970	2510	510	3								
	800	6130	4150	9	1053	5450	3870	8	4690	3560	805	6	3750	3200	644	4								
	1000	7470	5020	13	1282	6670	4680	11	5780	4330	993	8	4770	3940	820	6								
	1200	8660	5700	19	1486	7900	5370	16	6770	5020	1215	17	6190	4660	1063	13								
FWB09	600	4680	3200	6	804	4120	2960	5	3420	2680	587	3	2970	2510	510	3								
	800	6130	4150	9	1053	5450	3870	8	4690	3560	805	6	3750	3200	644	4								
	1000	7470	5020	13	1282	6670	4680	11	5780	4330	993	8	4770	3940	820	6								
	1200	8660	5700	19	1486	7900	5370	16	6770	5020	1215	17	6190	4660	1063	13								
FWB10	600	4680	3200	6	804	4120	2960	5	3420	2680	587	3	2970	2510	510	3								
	800	6130	4150	9	1053	5450	3870	8	4690	3560	805	6	3750	3200	644	4								
	1000	7470	5020	13	1282	6670	4680	11	5780	4330	993	8	4770	3940	820	6								
	1200	8660	5700	19	1486	7900	5370	16	6770	5020	1215	17	6190	4660	1063	13								

4TW60292-1 (Sheet 2/6)

5 Capacity tables

5 - 2 Capacity tables with glycol for process cooling applications

Cooling mode

Glycol percentage in weight	Freezing temperature (°C)	Capacity correction factor	Pressure drop correction factor
0	0	1	1.00
10	-4	0.93	1.09
20	-10	0.84	1.18
30	-16	0.76	1.27
40	-24	0.76	1.36

Heating mode

Glycol percentage in weight	Freezing temperature (°C)	Capacity correction factor	Pressure drop correction factor
0	0	1	1.00
10	-4	0.98	1.08
20	-10	0.97	1.11
30	-16	0.94	1.22
40	-24	0.91	1.33

4TW60228-1B

Correction factors are based on an average value (at rated water flow rate). This can cause deviation depending on conditions used. The Fan Coil Selection software will provide an accurate result at all conditions.

3

5

5 Capacity tables

5 - 3 Heating capacity tables - 2-pipe

Air temperature (°C) Water temperature (Entering °C - leaving °C)		19								
		50 - 45		60 - 50		70 - 60		90 - 70		
Model	Air flow m ³ /h	Heating capacity W	Water flow ℓ/h	Water pressure drop kPa	Heating capacity W	Water flow ℓ/h	Water pressure drop kPa	Heating capacity W	Water flow ℓ/h	Water pressure drop kPa
FWB02	300	2230	388	5	3450	301	3	4420	388	5
	400	2830	493	8	4370	382	5	5600	491	7
	500	3380	588	10	5220	456	6	6690	587	9
FWB03	300	2420	421	7	3770	329	5	4770	419	7
	400	3120	543	11	4850	424	7	6150	540	10
	500	3780	657	16	5860	512	10	7450	654	14
FWB04	300	2560	445	5	4010	350	3	5040	442	5
	400	3360	585	9	5260	460	5	6620	581	8
	500	4140	720	12	6460	565	8	8150	715	11
FWB05	600	4250	739	9	6580	574	6	8400	737	9
	800	5340	928	14	8230	719	8	10550	926	13
	1000	6330	1100	19	9740	851	11	12520	1098	17
FWB06	600	4610	802	5	7150	624	3	9140	802	4
	800	5900	1026	7	9130	798	5	11660	1023	7
	1000	7080	1231	10	10940	955	6	14000	1229	9
FWB07	600	4930	856	8	7680	671	5	9710	852	7
	800	6380	1110	12	9930	868	7	12570	1103	11
	1000	7750	1348	17	12040	1053	10	15280	1341	15
FWB08	1000	6770	1177	14	10450	913	9	13380	1174	13
	1200	7790	1355	18	12010	1049	11	15400	1351	17
	1400	8750	1522	22	13470	1177	14	17310	1518	20
FWB09	1000	7520	1307	14	11660	1018	8	14820	1301	12
	1200	8740	1520	18	13540	1183	11	17250	1514	16
	1400	9910	1723	22	15320	1339	13	19570	1717	20
FWB10	1000	8270	1439	15	12920	1129	9	16280	1429	14
	1200	9770	1698	20	15230	1330	13	19220	1687	18
	1400	11210	1948	26	17450	1525	16	22070	1936	23

4TW60292-1 (Sheet 3/6)

5 Capacity tables

5 - 3 Heating capacity tables - 2-pipe

3
5

Air temperature (°C) Water temperature (Entering °C - leaving °C)		20											
		50 - 45		60 - 50		70 - 60		90 - 70					
Model	Air flow m ³ /h	Heating capacity W	Water flow ℓ/h	Water pressure drop kPa	Heating capacity W	Water flow ℓ/h	Water pressure drop kPa	Heating capacity W	Water flow ℓ/h	Water pressure drop kPa			
FWB02	300	2130	370	5	3350	292	3	4320	379	4	5840	258	2
	400	2700	470	7	4240	371	4	5470	480	7	7380	326	3
	500	3230	562	10	5060	442	6	6530	573	9	8780	388	4
	300	2310	402	7	3660	320	4	4660	409	6	6380	282	3
	400	2980	519	11	4710	412	7	6010	527	10	8190	362	5
FWB03	500	3610	628	15	5690	497	9	7280	638	14	9890	436	7
	300	2450	426	5	3890	340	3	4930	432	5	6810	301	2
	400	3220	560	8	5110	446	5	6470	567	8	8920	394	4
	500	3960	689	12	6280	549	7	7960	698	11	10940	483	5
	600	4060	707	9	5820	508	8	8200	720	8	11080	489	4
FWB05	800	5100	886	13	7990	698	8	10310	904	12	13860	612	6
	1000	6040	1051	17	9450	826	11	12220	1072	16	16380	723	8
	600	4410	766	4	6610	578	12	8920	783	4	12110	535	2
	800	5640	980	7	8850	774	4	11390	999	7	15400	680	3
	1000	6760	1176	9	10610	927	6	13680	1199	9	18430	814	4
FWB06	600	4710	819	7	7400	646	10	9480	832	7	13020	575	3
	800	6110	1062	11	9650	843	7	12280	1077	10	16790	741	5
	1000	7410	1290	15	11700	1022	10	14920	1309	15	20340	898	7
	1000	6470	1125	13	10140	886	8	13060	1146	13	17590	776	6
	1200	7440	1294	17	11650	1018	11	15050	1319	16	20200	892	8
FWB07	1400	8360	1453	21	13070	1142	13	16900	1483	20	22650	1000	9
	1000	7190	1249	13	11320	988	8	14480	1271	12	19660	868	6
	1200	8360	1453	16	13140	1148	10	16850	1479	15	22810	1007	8
	1400	9470	1646	20	14870	1300	13	19110	1676	19	25810	1140	9
	1000	7920	1377	14	12550	1097	9	15900	1395	13	21880	965	7
FWB10	1200	9340	1625	19	14790	1292	12	18780	1647	18	25760	1137	9
	1400	10720	1864	24	16950	1481	15	21550	1891	22	29490	1302	11

4TW60292-1 (Sheet 4/6)

5 Capacity tables

5 - 4 Heating capacity tables additional heat exchanger

Air temperature (°C) Water temperature (Entering °C - leaving °C)		19																																								
		50 - 45				60 - 50				70 - 60				90 - 70																												
		Heating capacity W	Water flow ℓ/h	Water pressure drop kPa	Air flow m ³ /h	Heating capacity W	Water flow ℓ/h	Water pressure drop kPa	Air flow m ³ /h	Heating capacity W	Water flow ℓ/h	Water pressure drop kPa	Air flow m ³ /h	Heating capacity W	Water flow ℓ/h	Water pressure drop kPa	Air flow m ³ /h																									
EAH04A6	300	1350	3	236	2050	179	2	2750	241	3	3550	157	1	EAH07A6	600	2630	4	457	3990	348	3	5270	462	4	6870	303	2	EAH10A6	1000	3430	7	596	5210	455	4	6870	602	7	8900	393	3	4TW60292-1 (Sheet 5/6)
	400	1590	4	277	2410	211	2	3220	282	4	4160	184	2		800	3070	6	533	4660	408	3	6140	538	5	7980	352	2		1200	6610	9	1149	13120	1150	8	17330	765	4				
	500	1790	5	312	2710	237	3	3610	317	4	4670	206	2		1400	7350	11	1278	11260	984	6	14600	1281	10	19260	850	5															

5 Capacity tables

5 - 4 Heating capacity tables additional heat exchanger

3
5

Air temperature (°C) Water temperature (Entering °C - leaving °C)		20								
		50 - 45		60 - 50		70 - 60		90 - 70		
Model	Air flow m ³ /h	Heating capacity W	Water flow ℓ/h	Water pressure drop kPa	Heating capacity W	Water flow ℓ/h	Water pressure drop kPa	Heating capacity W	Water flow ℓ/h	Water pressure drop kPa
EAH04A6	300	1290	224	3	1980	173	2	2680	235	3
	400	1510	263	3	2330	203	2	3140	275	3
	500	1700	296	4	2620	229	3	3520	309	4
	600	2500	434	4	3860	337	2	5140	451	4
EAH07A6	800	2920	508	5	4510	394	3	5990	526	5
	1000	3270	568	7	5040	441	4	6700	588	6
	1000	5540	963	6	8620	753	4	11250	986	6
EAH10A6	1200	6310	1096	8	9820	858	5	12800	1123	8
	1400	7020	1220	10	10910	954	6	14260	1250	9

4TW60292-1 (Sheet 6/6)

5 Capacity tables

5 - 5 Power consumption

FWB02-04

Speed	7 (Max.)		6		5		4		3		2		1 (Min.)	
AP	Power input	Current	Power input	Current	Power input	Current	Power input	Current	Power input	Current	Power input	Current	Power input	Current
(Pa)	(W)	(A)	(W)	(A)	(W)	(A)	(W)	(A)	(W)	(A)	(W)	(A)	(W)	(A)
0	106	0.506	85	0.413	69	0.342	56	0.285	47	0.241	40	0.208	34	0.180
20	100	0.483	81	0.394	66	0.326	54	0.273	45	0.232	38	0.200	32	0.173
40	96	0.463	76	0.374	63	0.309	51	0.260	43	0.222	36	0.192		
60	90	0.438	71	0.355	60	0.296	49	0.250						
80	84	0.415	68	0.340	56	0.282								
100	80	0.399	65	0.326										

4TW60291-2 (2/4)

3
5

FWB05-07

Speed	7 (Max.)		6		5		4		3		2		1 (Min.)	
AP	Power input	Current	Power input	Current	Power input	Current	Power input	Current	Power input	Current	Power input	Current	Power input	Current
(Pa)	(W)	(A)	(W)	(A)	(W)	(A)	(W)	(A)	(W)	(A)	(W)	(A)	(W)	(A)
0	192	0.944	167	0.842	156	0.789	143	0.736	115	0.592	92	0.487	76	0.408
20	182	0.893	160	0.809	150	0.752	136	0.695	108	0.560	88	0.463	73	0.390
40	170	0.837	150	0.752	141	0.708	130	0.660	103	0.531	85	0.443	70	0.372
60	156	0.778	141	0.708	132	0.664	122	0.618	98	0.504	80	0.420	68	0.360
80	148	0.728	131	0.658	124	0.621	115	0.581	92	0.475	77	0.399		
100	138	0.684	122	0.613	115	0.580	107	0.545	88	0.447				

4TW60291-2 (3/4)

5 Capacity tables

5 - 6 Capacity correction factor

FWB08-10

Speed	7 (Max.)		6		5		4		3		2		1 (Min.)	
	AP	Power input	Current	Power input	Current	Power input	Current	Power input	Current	Power input	Current	Power input	Current	Power input
(Pa)	(W)	(A)	(W)	(A)	(W)	(A)	(W)	(A)	(W)	(A)	(W)	(A)	(W)	(A)
0	294	1.274	252	1.104	224	0.995	193	0.878	177	0.817	164	0.761	155	0.727
20	278	1.210	240	1.045	211	0.930	181	0.810	168	0.768	155	0.718	149	0.688
40	265	1.157	223	0.985	198	0.872	170	0.763	160	0.723	148	0.680	142	0.650
60	251	1.100	211	0.927	184	0.815	158	0.709	148	0.670	138	0.627	135	0.606
80	236	1.035	200	0.876	172	0.753	145	0.650	138	0.615				
100	224	0.980	186	0.815										

4TW60291-2 (4/4)

3

5

5 Capacity tables

5 - 6 Capacity correction factor

ESP (Pa)	10		20		30		40		50		60		70		80		90		
	F1	F2	F1	F2	F1	F2	F1	F2	F1	F2	F1	F2	F1	F2	F1	F2	F1	F2	
FWB02	Fan speed																		
	Min. (1)	0.83	0.85	0.67	0.74	0.51	0.62	0.35	0.46										
	Med. (4)	0.91	0.92	0.82	0.84	0.73	0.76	0.64	0.66	0.56	0.59	0.47	0.53	0.38	0.46	0.29	0.38	0.21	0.29
FWB03	Max. (7)	0.95	0.96	0.89	0.91	0.83	0.86	0.78	0.82	0.72	0.77	0.66	0.71	0.61	0.66	0.55	0.60	0.49	0.54
	Min. (1)	0.83	0.84	0.67	0.69	0.51	0.56	0.35	0.40										
	Med. (4)	0.91	0.92	0.82	0.84	0.73	0.75	0.64	0.67	0.56	0.58	0.47	0.49	0.38	0.42	0.29	0.34	0.21	0.25
FWB04	Max. (7)	0.95	0.95	0.89	0.91	0.83	0.86	0.78	0.81	0.72	0.76	0.66	0.71	0.61	0.65	0.55	0.59	0.49	0.53
	Min. (1)	0.83	0.84	0.67	0.70	0.51	0.55	0.35	0.39										
	Med. (4)	0.91	0.91	0.82	0.83	0.73	0.74	0.64	0.65	0.56	0.57	0.47	0.50	0.38	0.42	0.29	0.33	0.21	0.24
FWB05	Max. (7)	0.95	0.95	0.89	0.90	0.83	0.85	0.78	0.80	0.72	0.74	0.66	0.69	0.61	0.63	0.55	0.57	0.49	0.51
	Min. (1)	0.88	0.88	0.76	0.77	0.64	0.69	0.53	0.61	0.42	0.51	0.31	0.40						
	Med. (4)	0.96	0.96	0.91	0.93	0.86	0.89	0.82	0.84	0.76	0.80	0.71	0.75	0.65	0.69	0.59	0.63	0.53	0.57
FWB06	Max. (7)	0.96	0.97	0.92	0.93	0.87	0.90	0.83	0.86	0.78	0.82	0.73	0.78	0.68	0.74	0.63	0.69	0.58	0.65
	Min. (1)	0.88	0.92	0.76	0.83	0.64	0.74	0.53	0.64	0.42	0.53	0.31	0.40						
	Med. (4)	0.96	0.96	0.91	0.91	0.86	0.87	0.82	0.82	0.76	0.76	0.71	0.70	0.65	0.65	0.59	0.61	0.53	0.57
FWB07	Max. (7)	0.96	0.96	0.92	0.93	0.87	0.89	0.83	0.85	0.78	0.80	0.73	0.76	0.68	0.71	0.63	0.66	0.58	0.61
	Min. (1)	0.88	0.90	0.76	0.81	0.64	0.70	0.53	0.60	0.42	0.48	0.31	0.36						
	Med. (4)	0.96	0.96	0.91	0.92	0.86	0.87	0.82	0.83	0.76	0.78	0.71	0.73	0.65	0.67	0.59	0.61	0.53	0.54
FWB08	Max. (7)	0.96	0.96	0.92	0.93	0.87	0.89	0.83	0.85	0.78	0.81	0.73	0.76	0.68	0.71	0.63	0.67	0.58	0.62
	Min. (1)	0.91	0.92	0.81	0.83	0.71	0.73	0.60	0.62	0.48	0.51	0.35	0.41						
	Med. (4)	0.93	0.94	0.85	0.88	0.77	0.81	0.68	0.73	0.59	0.64	0.49	0.54	0.38	0.42	0.25	0.31		
FWB09	Max. (7)	0.95	0.96	0.89	0.92	0.84	0.88	0.77	0.83	0.71	0.77	0.64	0.71	0.57	0.64	0.49	0.57	0.40	0.48
	Min. (1)	0.91	0.92	0.81	0.82	0.71	0.72	0.60	0.61	0.48	0.51	0.35	0.40						
	Med. (4)	0.93	0.94	0.85	0.87	0.77	0.80	0.68	0.72	0.59	0.63	0.49	0.52	0.38	0.40	0.25	0.30		
FWB10	Max. (7)	0.95	0.96	0.89	0.91	0.84	0.86	0.77	0.81	0.71	0.76	0.64	0.70	0.57	0.63	0.49	0.55	0.40	0.46
	Min. (1)	0.91	0.91	0.81	0.82	0.71	0.72	0.60	0.60	0.48	0.50	0.35	0.38						
	Med. (4)	0.93	0.93	0.85	0.86	0.77	0.78	0.68	0.70	0.59	0.61	0.49	0.51	0.38	0.39	0.25	0.27		
Max. (7)	0.95	0.96	0.89	0.91	0.84	0.86	0.77	0.80	0.71	0.74	0.64	0.68	0.57	0.60	0.49	0.52	0.40	0.43	

4TW60298-1

Conditions

Cooling

Heating 2-pipe

Air: 27°C DB - 19°C WB - Water: entering 7°C - leaving 12°C
 Air: 20°C Water: entering 50°C water flow as for cooling

F1 = correction factor for air flow
 F2 = correction factor for capacities

Correction factors are based on an average value. This can cause deviation depending on conditions used. The Fan Coil Selection software will provide an accurate result at all conditions.

6 Dimensional drawing & centre of gravity

6 - 1 Dimensional drawing

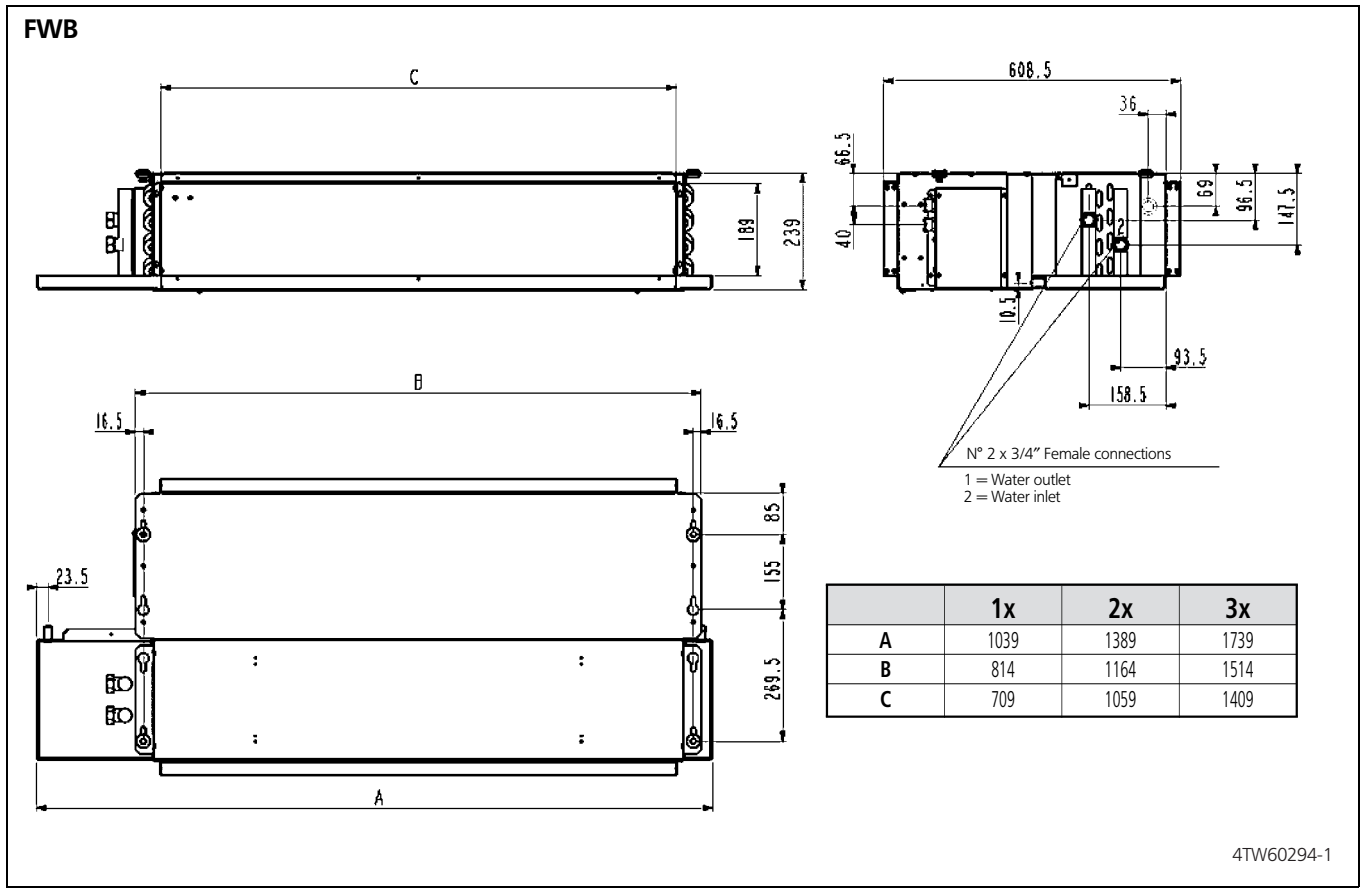

3
6

7 Wiring diagram

7 - 1 Wiring diagram

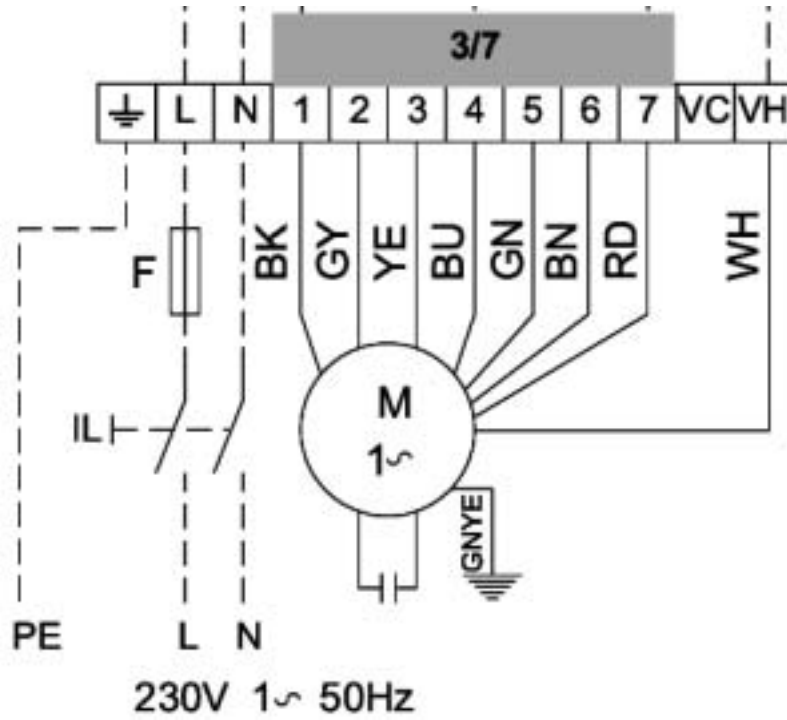

SYMBOLS

BK	Black = maximum speed
BU	Blue = medium speed
GNYE	Yellow/Green = earth connection
RD	Red = minimum speed
WH	White = common
----	Field wiring
F	Protection fuse (field supply)
IL	Main switch (field supply)
M	Fan motor
PE	Earth connection

4TW60296-1

8 Sound data

8 - 1 Sound power spectrum - 2-pipe

FWB02-04		125 Hz	250 Hz	500 Hz	1000 Hz	2000 Hz	4000 Hz	8000 Hz	
7	Lw tot dB(A)	54	57	55	53	51	45	36	58
		125 Hz	250 Hz	500 Hz	1000 Hz	2000 Hz	4000 Hz	8000 Hz	
	Outlet	50	54	52	50	48	43	33	-
	Structure	37	40	47	36	43	27	19	-
	Inlet	52	54	51	49	45	40	32	-
6	Lw tot dB(A)	50	53	51	48	46	36	25	52
		125 Hz	250 Hz	500 Hz	1000 Hz	2000 Hz	4000 Hz	8000 Hz	
	Outlet	46	50	48	46	44	34	23	-
	Structure	33	35	42	31	38	18	8	-
	Inlet	48	50	47	44	41	31	21	-
5	Lw tot dB(A)	47	50	48	44	42	34	23	50
		125 Hz	250 Hz	500 Hz	1000 Hz	2000 Hz	4000 Hz	8000 Hz	
	Outlet	43	47	44	42	40	32	21	-
	Structure	30	32	39	27	34	16	6	-
	Inlet	45	46	43	41	37	29	19	-
4	Lw tot dB(A)	44	46	44	41	37	27	20	46
		125 Hz	250 Hz	500 Hz	1000 Hz	2000 Hz	4000 Hz	8000 Hz	
	Outlet	39	43	40	38	35	25	17	-
	Structure	27	28	35	24	29	10	3	-
	Inlet	41	43	40	37	32	23	16	-
3	Lw tot dB(A)	41	44	41	38	34	23	19	43
		125 Hz	250 Hz	500 Hz	1000 Hz	2000 Hz	4000 Hz	8000 Hz	
	Outlet	37	41	38	35	31	21	16	-
	Structure	24	26	32	21	25	5	2	-
	Inlet	39	40	37	34	28	18	15	-
2	Lw tot dB(A)	39	41	38	35	30	17	18	40
		125 Hz	250 Hz	500 Hz	1000 Hz	2000 Hz	4000 Hz	8000 Hz	
	Outlet	35	38	35	32	27	15	15	-
	Structure	22	23	30	18	22	nm	nm	-
	Inlet	37	38	34	31	24	13	14	-
1	Lw tot dB(A)	35	38	34	31	26	15	17	36
		125 Hz	250 Hz	500 Hz	1000 Hz	2000 Hz	4000 Hz	8000 Hz	
	Outlet	31	35	31	28	23	13	15	-
	Structure	18	20	26	14	17	nm	nm	-
	Inlet	33	34	30	27	20	10	14	-

4TW60297-1 (Sheet 1/3)

To calculate the sound pressure you must define some conditions and use this formula

$$L_p = L_w - 10 \times \log_{10} \left(\frac{4\pi \times d^2}{Q} \right)$$

Where:

Q = direction factor: is Q=4 if the FCU is installed near 2 walls (vertical or floor-ceiling), Q=2 if the FCU is installed near 1 wall (at floor or ceiling but faraway the 2nd wall)

d = distance (mt) from the sound source and the measure point

LP = Sound pressure (dBA)

Lw = Sound power (dBA)

Conditions of measurements

ISO3741 = The sound power is calculated WITHOUT any additional inlet or outlet grill or plenum.

nm = Not measurable

8 Sound data

8 - 1 Sound power spectrum - 2-pipe

FWB05-07		125 Hz	250 Hz	500 Hz	1000 Hz	2000 Hz	4000 Hz	8000 Hz	
7	Lw tot dB(A)	55	59	59	54	52	46	37	60
		125 Hz	250 Hz	500 Hz	1000 Hz	2000 Hz	4000 Hz	8000 Hz	
	Outlet	51	57	55	52	49	44	34	-
	Structure	38	42	50	37	43	28	20	-
	Inlet	53	56	55	50	46	42	33	-
6	Lw tot dB(A)	52	56	55	50	47	39	29	56
		125 Hz	250 Hz	500 Hz	1000 Hz	2000 Hz	4000 Hz	8000 Hz	
	Outlet	48	53	52	47	44	37	27	-
	Structure	35	38	46	33	38	22	12	-
	Inlet	50	52	51	46	41	35	25	-
5	Lw tot dB(A)	49	55	54	47	44	34	24	54
		125 Hz	250 Hz	500 Hz	1000 Hz	2000 Hz	4000 Hz	8000 Hz	
	Outlet	44	52	51	45	41	32	21	-
	Structure	32	37	45	30	36	17	7	-
	Inlet	46	51	50	44	38	30	20	-
4	Lw tot dB(A)	46	52	52	45	41	32	21	52
		125 Hz	250 Hz	500 Hz	1000 Hz	2000 Hz	4000 Hz	8000 Hz	
	Outlet	42	49	49	43	39	30	18	-
	Structure	29	35	43	28	33	14	4	-
	Inlet	44	49	48	42	36	28	17	-
3	Lw tot dB(A)	45	49	47	41	36	25	16	47
		125 Hz	250 Hz	500 Hz	1000 Hz	2000 Hz	4000 Hz	8000 Hz	
	Outlet	41	46	43	38	34	23	14	-
	Structure	28	31	38	24	28	7	nm	-
	Inlet	43	46	43	37	31	21	13	-
2	Lw tot dB(A)	41	45	43	36	30	17	15	43
		125 Hz	250 Hz	500 Hz	1000 Hz	2000 Hz	4000 Hz	8000 Hz	
	Outlet	37	42	39	33	27	15	12	-
	Structure	24	28	34	19	21	nm	nm	-
	Inlet	39	42	38	32	24	12	11	-
1	Lw tot dB(A)	37	41	37	30	20	11	14	37
		125 Hz	250 Hz	500 Hz	1000 Hz	2000 Hz	4000 Hz	8000 Hz	
	Outlet	33	38	34	27	18	9	12	-
	Structure	20	23	29	13	12	nm	nm	-
	Inlet	35	37	33	26	15	6	11	-

4TW60297-1 (Sheet 2/3)

To calculate the sound pressure you must define some conditions and use this formula

$$L_p = L_w - 10 \times \log_{10} \left(\frac{4\pi \times d^2}{Q} \right)$$

Where:

Q = direction factor: is Q=4 if the FCU is installed near 2 walls (vertical or floor-ceiling), Q=2 if the FCU is installed near 1 wall (at floor or ceiling but faraway the 2nd wall)

d = distance (mt) from the sound source and the measure point

LP = Sound pressure (dBA)

Lw = Sound power (dBA)

Conditions of measurements

ISO3741 = The sound power is calculated WITHOUT any additional inlet or outlet grill or plenum.

nm = Not measurable

8 Sound data

8 - 1 Sound power spectrum - 2-pipe

FWB08-10		125 Hz	250 Hz	500 Hz	1000 Hz	2000 Hz	4000 Hz	8000 Hz	
7	Lw tot dB(A)	63	67	65	64	61	55	49	69
		125 Hz	250 Hz	500 Hz	1000 Hz	2000 Hz	4000 Hz	8000 Hz	
	Outlet	59	64	62	62	59	53	46	-
	Structure	46	49	57	47	53	38	32	-
	Inlet	61	63	61	61	56	51	45	-
6	Lw tot dB(A)	61	64	63	63	60	53	46	67
		125 Hz	250 Hz	500 Hz	1000 Hz	2000 Hz	4000 Hz	8000 Hz	
	Outlet	57	61	60	60	57	51	43	-
	Structure	44	47	55	46	51	35	29	-
	Inlet	59	61	59	59	54	48	42	-
5	Lw tot dB(A)	58	60	61	60	56	49	41	64
		125 Hz	250 Hz	500 Hz	1000 Hz	2000 Hz	4000 Hz	8000 Hz	
	Outlet	54	57	58	58	54	47	39	-
	Structure	41	43	52	43	48	31	24	-
	Inlet	56	57	57	57	51	44	37	-
4	Lw tot dB(A)	52	55	56	54	51	43	34	58
		125 Hz	250 Hz	500 Hz	1000 Hz	2000 Hz	4000 Hz	8000 Hz	
	Outlet	48	52	53	51	49	41	31	-
	Structure	35	37	47	37	43	26	17	-
	Inlet	50	51	52	50	45	39	30	-
3	Lw tot dB(A)	50	53	54	51	50	41	31	56
		125 Hz	250 Hz	500 Hz	1000 Hz	2000 Hz	4000 Hz	8000 Hz	
	Outlet	46	50	51	49	47	39	28	-
	Structure	33	35	46	34	41	23	14	-
	Inlet	48	49	50	48	44	36	27	-
2	Lw tot dB(A)	51	50	52	49	47	39	28	54
		125 Hz	250 Hz	500 Hz	1000 Hz	2000 Hz	4000 Hz	8000 Hz	
	Outlet	47	47	49	47	45	36	26	-
	Structure	34	33	44	32	39	21	11	-
	Inlet	49	47	48	45	42	34	25	-
1	Lw tot dB(A)	46	49	51	48	46	38	28	53
		125 Hz	250 Hz	500 Hz	1000 Hz	2000 Hz	4000 Hz	8000 Hz	
	Outlet	42	46	47	45	44	36	25	-
	Structure	29	31	42	31	38	20	11	-
	Inlet	44	46	47	44	41	33	24	-

4TW60297-1 (Sheet 3/3)

To calculate the sound pressure you must define some conditions and use this formula

$$L_p = L_w - 10 \times \log_{10} \left(\frac{4\pi \times d^2}{Q} \right)$$

Where:

Q = direction factor: is Q=4 if the FCU is installed near 2 walls (vertical or floor-ceiling), Q=2 if the FCU is installed near 1 wall (at floor or ceiling but faraway the 2nd wall)

d = distance (mt) from the sound source and the measure point

LP = Sound pressure (dBA)

Lw = Sound power (dBA)

Conditions of measurements

ISO3741 = The sound power is calculated WITHOUT any additional inlet or outlet grill or plenum.

nm = Not measurable

9 Installation

9 - 1 Installation method

BEFORE THE INSTALLATION

The equipment is to be installed and serviced exclusively by technical personnel who are qualified for using this type of machine, in compliance with the relevant local and national regulations.
On receiving the equipment, check its state ensuring that it was not damaged during transport. Refer to the associated technical sheets for the installation and use instructions of any accessories.

INTENDED CONDITIONS OF USE AND OPERATING LIMITS

No responsibility is assumed if the equipment is installed by unqualified personnel, if it is used improperly or under inadmissible conditions, if maintenance is not performed as envisaged in this manual or if original spare parts are not used. For the operating limits please refer to the appropriate chapter. Any other use is considered improper.

Keep the equipment inside the packing until it is ready to be installed so that dust will not infiltrate.

Air sucked by the equipment must always be filtered. Use, when possible, the specific accessories.

If not used during the winter, drain the water from the system to prevent damage caused by the formation of ice. If antifreeze solutions are used, check the freezing point.

Do not change the internal wiring or other parts of the equipment.

INSTALLATION WARNING:

On the thermal-ventilating unit install a switch (IL) and/or all remote controls in a position out of the reach of persons who are in a bathtub or shower.

The FWB units may be installed only in horizontal position. Check that the desired installation complies with one of the diagrams shown in the installation manual.

FIXING the unit

Fix the standard unit to the ceiling or wall using at least 4 of the 6 slots;

For the installation (ceiling-mounting) it is advisable to use M8 threaded bars, screw anchors suitable for the machine's weight, and to arrange for the positioning of the machine using 2 M8 bolts and a washer the diameter of which is suitable for inserting the slot and for then fixing the unit.

Before tightening the check nut, adjust the closing of the main nut so that the equipment will slant correctly, i.e. for facilitating the discharging of the condensate.

The correct slant is achieved by tilting the intake downwards as compared to the delivery, until a difference in level of about 10 mm is obtained from one end to the other. Make the hydraulic connections with the heat exchanger and, for cooling operations, with the condensate discharge.

Use one of the two drains of the auxiliary tank, visible on the outside of the unit's side panels and vertical condensate discharge.

4TW60299-3 (Sheet 1/2)

9 Installation

9 - 1 Installation method

A few rules to follow

Carry out the heat exchanger's air exhaust, with pumps stopped, by means of the air valves located adjacent to the attachments of the heat exchanger itself.

When implementing a duct system, it is advisable to place the vibration-damping joints between the ducting and the unit. If you wish to install an electrical resistance module as accessory, the delivery vibration-damping joint should be heat-resistant. The ducting, especially the delivery one, should be insulated with anticondensing material.

Provide an inspection panel adjacent to the equipment for the maintenance and cleaning operations.

Install the control panel on the wall. Choose a position that is easy to access for the setting of the functions and, if contemplated, for the reading of the temperature. Try to avoid positions that are directly exposed to sun rays, or positions subject to direct hot or cold air currents, and do not place obstacles in the way that would prevent the correct reading of the temperature.

ELECTRICAL CONNECTIONS

Make the electrical connections with voltage OFF, in compliance with the relevant local and national regulations.

Exclusively qualified personnel should carry out the wiring operations. **Each fancoil unit requires a switch (IL) on the feeder line with a distance of at least 3 mm between the opening contacts, and a suitable safety fuse (F).**

Power consumption is shown on the data plate fixed to the unit. Make sure to carefully execute the wiring in function of the combination unit/controller and this according to the correct wiring diagram delivered with every accessory. In order to make the electrical connections you must remove the lower closing panel to access the terminal board. The power cables (power supply and control) must be routed to the terminal board through the cable grip that is on the side panel of the machine on the same side of the hydraulic connections.

WARNING

The COMMON wire of the motor is the WHITE one: if connected incorrectly the motor would be damaged irreparably. See wiring diagrams for color codes.

FUNCTIONAL CHECKS

Check that the equipment has been installed so that it guarantees the required slant.

Check that the condensate discharge is not clogged (by rubble deposits, etc.).

Check the seal of the hydraulic connections.

Check that all the wirings are tight (perform the check with voltage OFF).

Make sure air has been purged from the heat exchanger.

Power the equipment and check its working efficiency.

Installation & service distances for FWB units

Consider at least

- 500 mm free space on water connections side (piping & connections) measured from the boundary of the drain pan.
- 200 mm free space on the opposite side (to unscrew heat exchangers or fan deck in case of repairing)
- Possibility to extract filter for cleaning has to be considered
- Possibility to reach the unit for ordinary and extraordinary maintenance (for instance removing front panels) has to be considered

4TW60229-3 (Sheet 2/4)

10 Operation range

Minimum water temperature	+5°C
Maximum water temperature	+95°C
Maximum operating pressure	10 bar
Minimum air inlet temperature	5°C
Maximum air inlet temperature	+43°C
Power supply	230V +-10% / 1~ / 50Hz

4TW60293-1

11 Water pressure drop curve evaporator

11 - 2 Water pressure drop curve evaporator heating 2-pipe

3

11

Water flow l/h	FWB								
	Water pressure drop								
	FWB02	FWB03	FWB04	FWB05	FWB06	FWB07	FWB08	FWB09	FWB10
	kPa	kPa	kPa	kPa	kPa	kPa	kPa	kPa	kPa
100	1	1	<1	<1	<1	<1	<1	<1	<1
200	2	2	2	1	<1	1	1	1	1
300	4	5	3	2	1	1	2	1	1
400	6	8	5	4	2	2	3	2	2
500	9	12	8	6	3	4	4	3	3
600	13	16	11	8	3	5	5	4	4
700	17	21	14	10	5	6	7	5	5
800	21	27	18	13	6	8	9	7	6
900	26	33	22	16	7	10	11	8	8
1000	32	40	27	19	9	12	13	10	10
1100	37	47	32	23	10	14	15	12	11
1200	44	55	37	26	12	16	18	14	13
1300	50	64	42	30	14	19	20	16	15
1400	57	72	48	35	15	21	23	18	17
1500	65	82	55	39	17	24	26	21	20
1600	72	92	61	44	20	27	29	23	22
1700	81	102	68	49	22	30	33	26	24
1800	89		75	54	24	33	36	29	27
1900	98		83	59	26	37	40	32	30
2000	107		91	65	29	40	44	34	32
2100			99	71	32	44	48	38	35
2200			107	77	34	48	52	41	38
2300				83	37	51	56	44	41
2400				89	40	55	60	48	45
2500				96	43	60	65	51	48
3000					59	82	89	70	66
3500					77	108	117	92	87
4000					98			117	110

4TW60299-1 (Sheet 1/3)

12-2 Water pressure drop curve evaporator heating 2-pipe

Water flow l/h	FWB								
	Water pressure drop								
	FWB02	FWB03	FWB04	FWB05	FWB06	FWB07	FWB08	FWB09	FWB10
	kPa	kPa	kPa	kPa	kPa	kPa	kPa	kPa	kPa
100	<1	1	<1	<1	<1	<1	<1	<1	<1
200	2	2	1	1	<1	1	1	1	<1
300	3	4	3	2	1	1	1	1	1
400	5	7	4	3	1	2	2	2	2
500	8	10	7	5	2	3	3	3	2
600	11	13	9	6	3	4	4	3	3
700	14	17	12	8	4	5	6	5	4
800	17	22	15	11	5	7	7	6	5
900	21	27	18	13	6	8	9	7	7
1000	26	32	22	16	7	10	11	8	8
1100	30	38	26	18	8	12	13	10	9
1200	35	45	30	21	10	13	15	12	11
1300	40	51	34	25	11	15	17	13	13
1400	46	58	39	28	13	17	19	15	14
1500	52	66	44	32	14	20	22	17	16
1600	58	74	49	35	16	22	24	19	18
1700	65	82	55	39	18	25	27	21	20
1800	71	90	60	43	19	27	30	23	22
1900	78	99	66	48	21	30	32	26	24
2000	86	109	73	52	23	33	35	28	27
2100	93		79	57	25	35	39	31	29
2200	101		86	62	28	38	42	33	31
2300	110		93	67	30	41	45	36	34
2400			100	72	32	45	49	39	36
2500			107	77	35	48	52	41	39
3000				106	47	66	72	57	54
3500					62	86	94	74	70
4000					78	109	119	94	89
4500					96			115	109
5000					116				

4TW60299-1 (Sheet 2/3)

11 Water pressure drop curve evaporator

11 - 3 Water pressure drop curve evaporator additional heat exchanger

FWB			
Water flow l/h	Water pressure drop		
	EAH04A6	EAH07A6	EAH10A6
	kPa	kPa	kPa
100	1	<1	<1
200	2	1	<1
300	4	2	1
400	7	3	1
500	10	5	2
600	13	7	3
700	17	9	3
800	22	11	4
900	27	13	5
1000	32	16	6
1100	38	19	8
1200	44	22	9
1300	51	25	10
1400	58	29	11
1500	66	32	13
1600	73	36	14
1700	82	40	16
1800	90	44	18
1900	99	49	19
2000	108	53	21
2100	118	58	23
2200		63	25
2300		68	27
2400		73	29
2500		79	31
3000		108	43
3500			56
4000			71
4500			87
5000			105

4TW60299-1 (Sheet 3/3)

