

# 2/3/4 NKVE 10 - 15 - 20 - 32 - 45 MCE/P

## CONSTANT PRESSURE SETS WITH MCE/P MULTI INVERTER SYSTEM ON THE PUMP



### TECHNICAL DATA

**Line voltage:** 400V three phase  
**Voltage of electric pump:** 400V three phase  
**Power frequency:** 50-60 Hz  
**Installation:** vertical only  
**Operating range:** from 4 to 280 m<sup>3</sup>/h  
**Pumped liquid temperature range:** from 0 °C to 80 °C  
**Maximum ambient temperature:** 40°C  
**Max pressure:** 14bar  
**Pumped liquid:** clean, free from solids.  
**Pressure regulation range:** 3 to 14 bar.  
**Protection class:** IP55

### APPLICATIONS

The sets with on-board inverter have been designed and manufactured to meet the constant pressure requirements of modern system engineering solutions. The constant pressure adjustment is a requirement in the most varied sectors: Water pipelines, Irrigation, Industry, Hotel, Residential building, Spas. The fundamental concept that has driven our Engineers in developing these pumps sets, was to offer a simple to use, flexible, and extremely reliable product. Differently from traditional fixed speed pumps, inverter driven pumps give the possibility to adapt the performance curve to the needs of the system. In the most classic case, inverter driven pumps are used to maintain constant pressure in the system against variations in the requested flow rate, avoiding pressure fluctuations caused by small flow rate variations.

### ADVANTAGES OF USE

Operating pressure stability – Excellent energy savings (up to 60 %) – Reduced hammering effects – Reduced space requirements – Less maintenance – Reduced pump wear – Less power factor correction required – Less water consumption – Integrated protections.

### CONSTRUCTION FEATURES

The sets with MCE/P inverters are built in the standard version with two, three, or four centrifugal electric pumps, completely assembled on galvanised steel base, tested and ready for installation. Complete with isolator and check valves for each pump, suction and delivery manifolds, expansion vessels, pressure sensor, on-pump inverter, protection control unit. (possibility of optional flow sensor for pressure control).

### MULTI INVERTER SYSTEM WITH ON-PUMP MCE/

The inverter continuously adjusts the rotation speed of the electric pump, keeping the pressure constant, even when the flow rate varies.

The other electric pumps, also with variable speed, are activated in cascade after the first one has reached maximum speed. Through modulation, they compensate the pressure fluctuations of the system.

For every operating cycle, it is possible to switch the restart to a different pump, therefore ensuring even use of all electric pumps.

It is possible to set operation times for each individual pump, switching to another pump after such set times.

The "SP" pressure can be adjusted by the user using the "+" and "-" keys found on the MCE/P (as a rule, all the pumps are set to the same pressure value). With the new MCE/P, it is sufficient to set the data on one of the devices, and it will be automatically propagated to the other pumps of the system.

### ELECTRIC COMPONENTS SUPPLIED

MCE/P inverter with the following features:

- Abnormal voltage protection.
- Adjustable amperometric protection.
- Dry run protection (without minimum manometer).
- Output phases short circuit protection.
- Overtemperature and overvoltage protection.
- Anti-seizing and anti-freeze functions.
- Pressure sensor fault.
- Thermal magnetic protection control unit (simplified connection).
- Pressure sensor on the delivery manifold.

## 2 NKVE 10 -MCE/P - CONSTANT PRESSURE BOOSTER SETS

Pumped liquid temperature range: from -15 °C to +80 °C - Maximum ambient temperature: +40 °C - Max flow rate: 26 m<sup>3</sup>/h

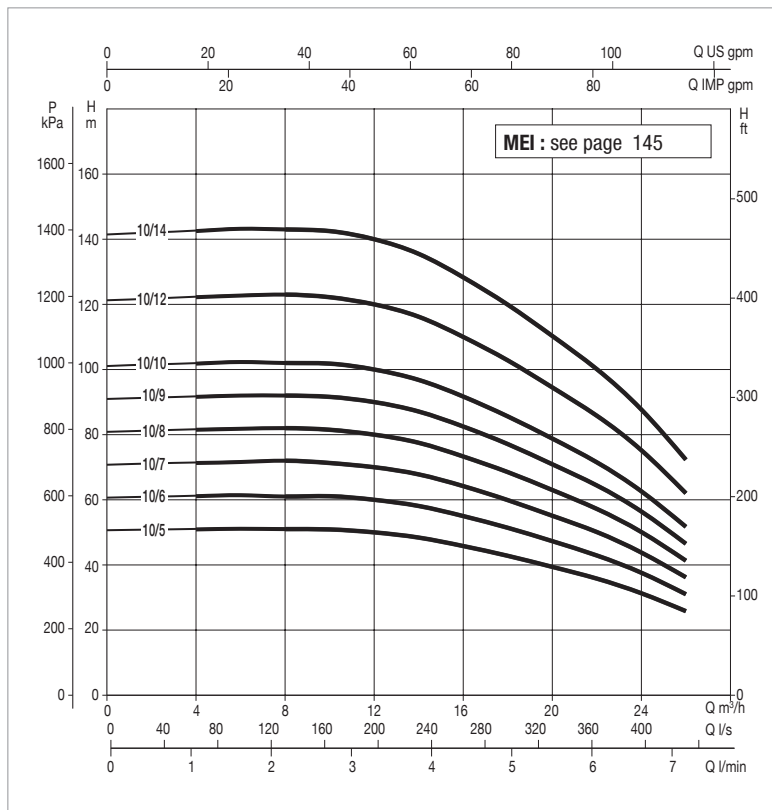
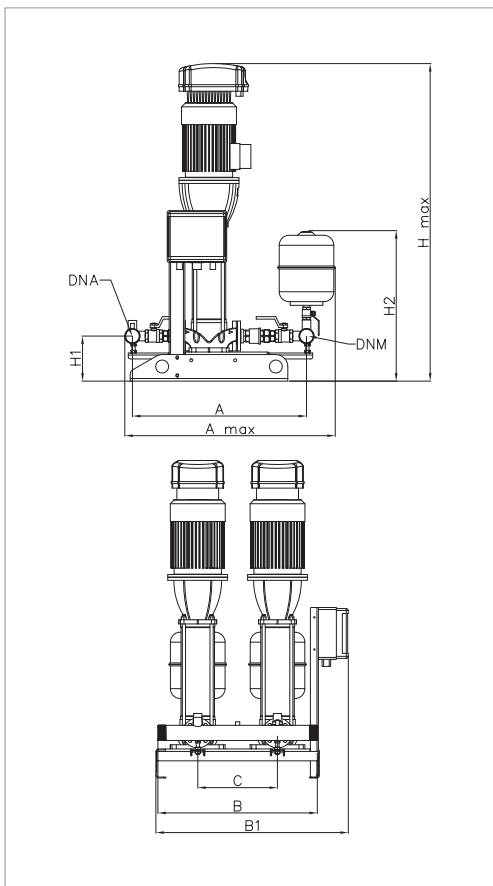

The performance curves are based on kinematic viscosity values = 1 mm<sup>2</sup>/s and density equal to 1000 kg/m<sup>3</sup>.  
Curve tolerance according to ISO 9906.

Overall performance taking into account TWO pumps working at the same time.

MODEL	PUMP+INVERTER POWER INPUT	P2 NOMINAL		In A	MCE/P MODEL	MAXIMUM FLOW RATE m <sup>3</sup> /h	MAX OBTAINABLE PRESSURE BAR	STANDARD PRESSURE BAR
		KW	HP					
2 NKVE 10/5 T MCE30/P	3 x 400V 50Hz	2x2.2	2x3	2x4.9	MCE30/P	26	5	4,0
2 NKVE 10/6 T MCE30/P	3 x 400V 50Hz	2x2.2	2x3	2x5.4	MCE30/P	26	6	5.0
2 NKVE 10/7 T MCE30/P	3 x 400V 50Hz	2x3	2x4	2x7.37	MCE30/P	26	7	6
2 NKVE 10/8 T MCE30/P	3 x 400V 50Hz	2x3	2x4	2x7.37	MCE30/P	26	8	6.5
2 NKVE 10/9 T MCE30/P	3 x 400V 50Hz	2x3	2x4	2x7.37	MCE30/P	26	9	7.7
2 NKVE 10/10 T MCE30/P	3 x 400V 50Hz	2x4	2x5.5	2x10.1	MCE30/P	26	10	8.5
2 NKVE 10/12 T MCE55/P	3 x 400V 50Hz	2x4	2x5.5	2x10.1	MCE55/P	26	12	10
2 NKVE 10/14 T MCE55/P	3 x 400V 50Hz	2x5.5	2x7.5	2x13.1	MCE55/P	26	14	10

MODEL	A	A MAX	B	B1	C	H1	H2	H MAX	DNA	DNM	PACKING DIMENSIONS			WEIGHT kg
											L/A	L/B	H	
2 NKVE 10/5 T MCE30/P	875	1060	800	965	400	226	755	1109	2" 1/2	2" 1/2	2150	1000	1400	186
2 NKVE 10/6 T MCE30/P	875	1060	800	965	400	226	755	1142	2" 1/2	2" 1/2	2150	1000	1400	187
2 NKVE 10/7 T MCE30/P	875	1060	800	965	400	226	755	1221	2" 1/2	2" 1/2	2150	1000	1400	214
2 NKVE 10/8 T MCE30/P	875	1060	800	965	400	226	755	1254	2" 1/2	2" 1/2	2150	1000	1400	216
2 NKVE 10/9 T MCE30/P	875	1060	800	965	400	226	755	1287	2" 1/2	2" 1/2	2150	1000	1400	218
2 NKVE 10/10 T MCE55/P	875	1060	800	965	400	226	755	1335	2" 1/2	2" 1/2	2150	1000	1400	237
2 NKVE 10/12 T MCE55/P	875	1060	800	965	400	226	755	1401	2" 1/2	2" 1/2	2150	1000	1400	240
2 NKVE 10/14 T MCE55/P	875	1060	800	965	400	226	755	1597	2" 1/2	2" 1/2	2150	1000	1400	298

## 2 NKVE 15 - MCE/P - CONSTANT PRESSURE BOOSTER SETS

Pumped liquid temperature range: from -15 °C to +80 °C - Maximum ambient temperature: +40 °C - Max flow rate: 48 m<sup>3</sup>/h

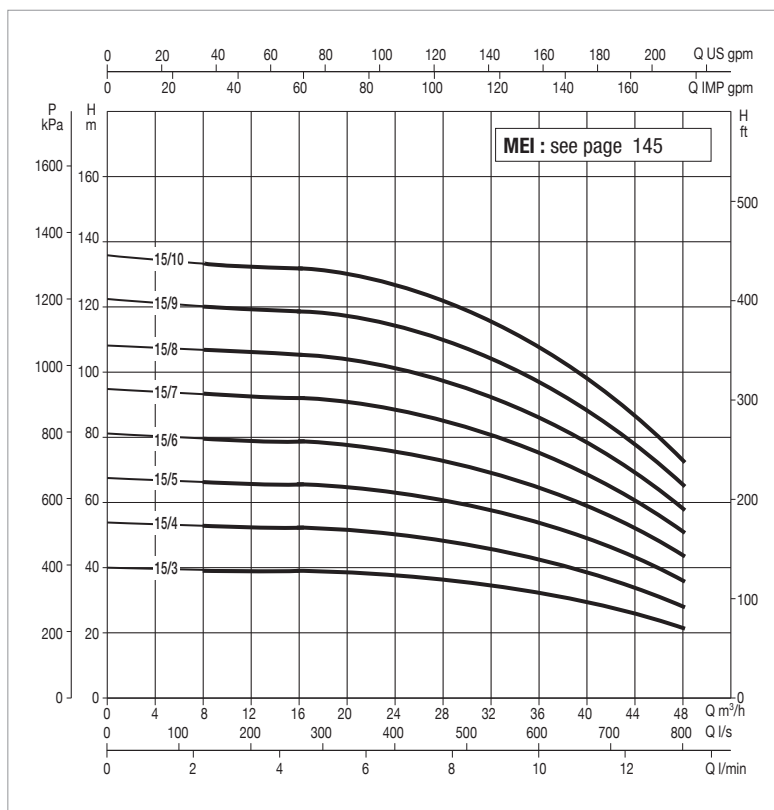
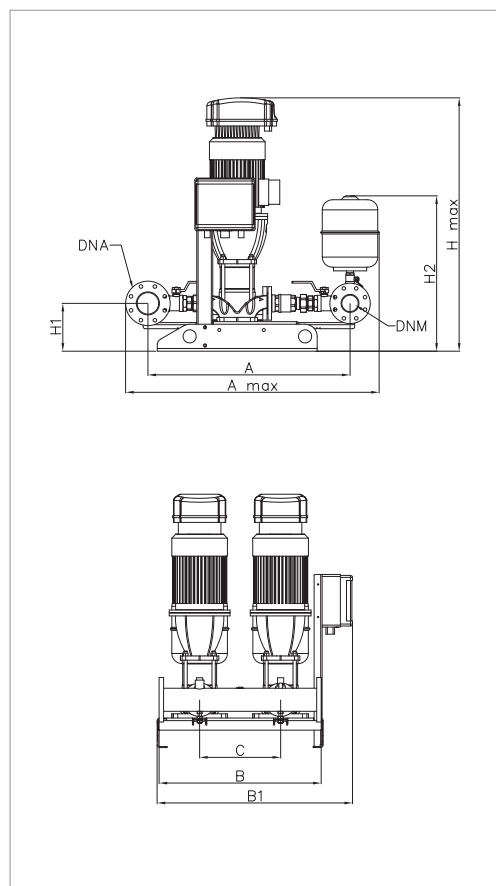

The performance curves are based on kinematic viscosity values = 1 mm<sup>2</sup>/s and density equal to 1000 kg/m<sup>3</sup>.  
Curve tolerance according to ISO 9906.

Overall performance taking into account TWO pumps working at the same time.

MODEL	PUMP+INVERTER POWER INPUT	P2 NOMINAL		In A	MCE/P MODEL	MAXIMUM FLOW RATE m <sup>3</sup> /h	MAX OBTAINABLE PRESSURE BAR	STANDARD PRESSURE BAR
		KW	HP					
2 NKVE 15/3 T MCE30/P	3 x 400V 50Hz	2x3	2x4	2x7.37	MCE30/P	48	4	3.5
2 NKVE 15/4 T MCE55/P	3 x 400V 50Hz	2x4	2x5.5	2x10.1	MCE55/P	48	5	4
2 NKVE 15/5 T MCE55/P	3 x 400V 50Hz	2x4	2x5.5	2x10.1	MCE55/P	48	6.5	5
2 NKVE 15/6 T MCE55/P	3 x 400V 50Hz	2x5.5	2x7.5	13.1	MCE55/P	48	7.5	6.5
2 NKVE 15/7 T MCE55/P	3 x 400V 50Hz	2x5.5	2x7.5	2x13.1	MCE55/P	48	9	8
2 NKVE 15/8 T MCE110/P	3 x 400V 50Hz	2x7.5	2x10	2x17.6	MCE110/P	48	11	10
2 NKVE 15/9 T MCE110/P	3 x 400V 50Hz	2x7.5	2x10	2x17.6	MCE110/P	48	12	11
2 NKVE 15/10 T MCE110/P	3 x 400V 50Hz	2x11	2x15	2x25.5	MCE110/P	48	13	12

MODEL	A	A MAX	B	B1	C	H1	H2	H MAX	DNA	DNM	PACKING DIMENSIONS			WEIGHT kg
											L/A	L/B	H	
2 NKVE 15/3 T MCE30/P	1000	1255	800	965	400	236	770	1160	100	80	2150	1000	1400	238
2 NKVE 15/4 T MCE55/P	1000	1255	800	965	400	236	770	1225	100	80	2150	1000	1400	258
2 NKVE 15/5 T MCE55/P	1000	1255	800	965	400	236	770	1274	100	80	2150	1000	1400	261
2 NKVE 15/6 T MCE55/P	1000	1255	800	965	400	236	770	1453	100	80	2150	1000	1400	317
2 NKVE 15/7 T MCE55/P	1000	1255	800	965	400	236	770	1503	100	80	2150	1000	1400	319
2 NKVE 15/8 T MCE110/P	1000	1255	800	965	400	236	770	1602	100	80	2150	1000	1400	344
2 NKVE 15/9 T MCE110/P	1000	1255	800	965	400	236	770	1652	100	80	2150	1000	1400	347
2 NKVE 15/10 T MCE110/P	1000	1255	800	965	400	236	770	1846	100	80	2150	1000	1400	459

## 2 NKVE 20 -MCE/P - CONSTANT PRESSURE BOOSTER SETS

Pumped liquid temperature range: from -15 °C to +80 °C - Maximum ambient temperature: +40 °C - Max flow rate: 58 m<sup>3</sup>/h

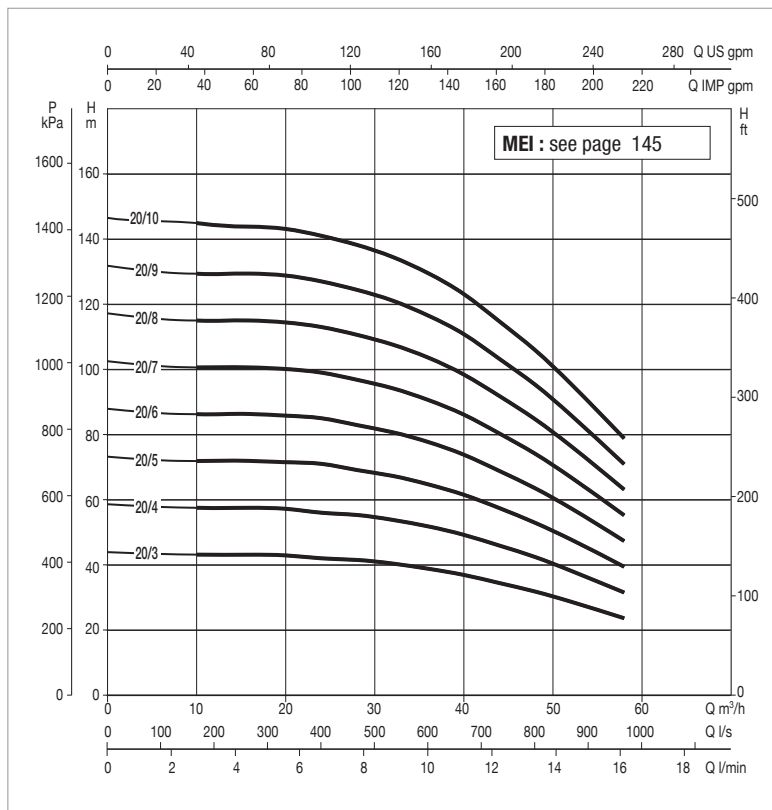
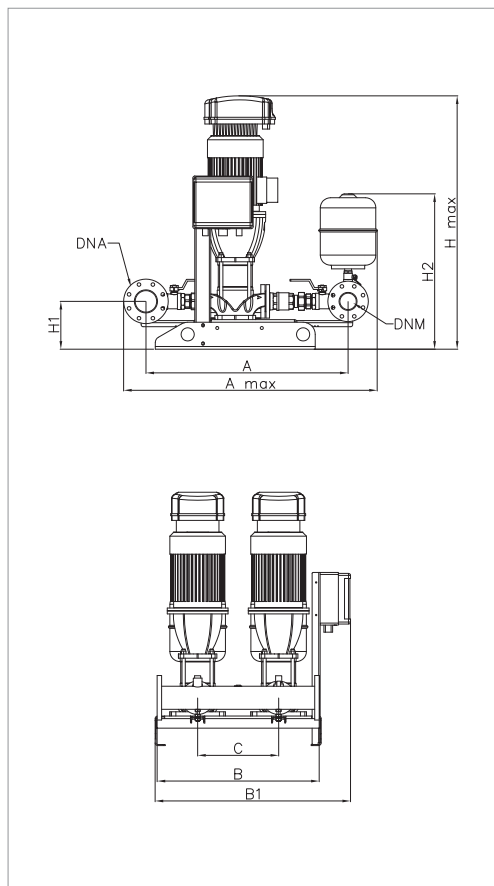

The performance curves are based on kinematic viscosity values = 1 mm<sup>2</sup>/s and density equal to 1000 kg/m<sup>3</sup>.  
Curve tolerance according to ISO 9906.

Overall performance taking into account TWO pumps working at the same time.

MODEL	PUMP+INVERTER POWER INPUT	P2 NOMINAL		In A	MCE/P MODEL	MAXIMUM FLOW RATE m <sup>3</sup> /h	MAX OBTAINABLE PRESSURE BAR	STANDARD PRESSURE BAR
		KW	HP					
2 NKVE 20/3 T MCE55/P	3 x 400V 50Hz	2x4	2x5.5	2x10.1	MCE55/P	58	4	3.5
2 NKVE 20/4 T MCE55/P	3 x 400V 50Hz	2x5.5	2x7.5	2x13.1	MCE55/P	58	6	5
2 NKVE 20/5 T MCE55/P	3 x 400V 50Hz	2x5.5	2x7.5	2x13.1	MCE55/P	58	7	6
2 NKVE 20/6 T MCE110/P	3 x 400V 50Hz	2x7.5	2x10	2x17.6	MCE110/P	58	8.5	7.5
2 NKVE 20/7 T MCE110/P	3 x 400V 50Hz	2x7.5	2x10	2x17.6	MCE110/P	58	10	9
2 NKVE 20/8 T MCE110/P	3 x 400V 50Hz	2x11	2x15	2x25.5	MCE110/P	58	11.5	10
2 NKVE 20/9 T MCE110/P	3 x 400V 50Hz	2x11	2x15	2x25.5	MCE110/P	58	13	12
2 NKVE 20/10 T MCE110/P	3 x 400V 50Hz	2x11	2x15	2x25.5	MCE110/P	58	14	13

MODEL	A	A MAX	B	B1	C	H1	H2	H MAX	DNA	DNM	PACKING DIMENSIONS			WEIGHT kg
											L/A	L/B	H	
2 NKVE 20/3 T MCE55/P	1000	1255	800	965	400	236	770	1175	100	80	2150	1000	1400	228
2 NKVE 20/4 T MCE55/P	1000	1255	800	965	400	236	770	1354	100	80	2150	1000	1400	256
2 NKVE 20/5 T MCE55/P	1000	1255	800	965	400	236	770	1404	100	80	2150	1000	1400	260
2 NKVE 20/6 T MCE110/P	1000	1255	800	965	400	236	770	1503	100	80	2150	1000	1400	284
2 NKVE 20/7 T MCE110/P	1000	1255	800	965	400	236	770	1553	100	80	2150	1000	1400	286
2 NKVE 20/8 T MCE110/P	1000	1255	800	965	400	236	770	1747	100	80	2150	1000	1400	350
2 NKVE 20/9 T MCE110/P	1000	1255	800	965	400	236	770	1796	100	80	2150	1000	1400	352
2 NKVE 20/10 T MCE110/P	1000	1255	800	965	400	236	770	1846	100	80	2150	1000	1400	374

## 2 NKVE 32 -MCE/P - CONSTANT PRESSURE BOOSTER SETS

Pumped liquid temperature range: from -15 °C to +80 °C - Maximum ambient temperature: +40 °C - Max flow rate: 90 m<sup>3</sup>/h

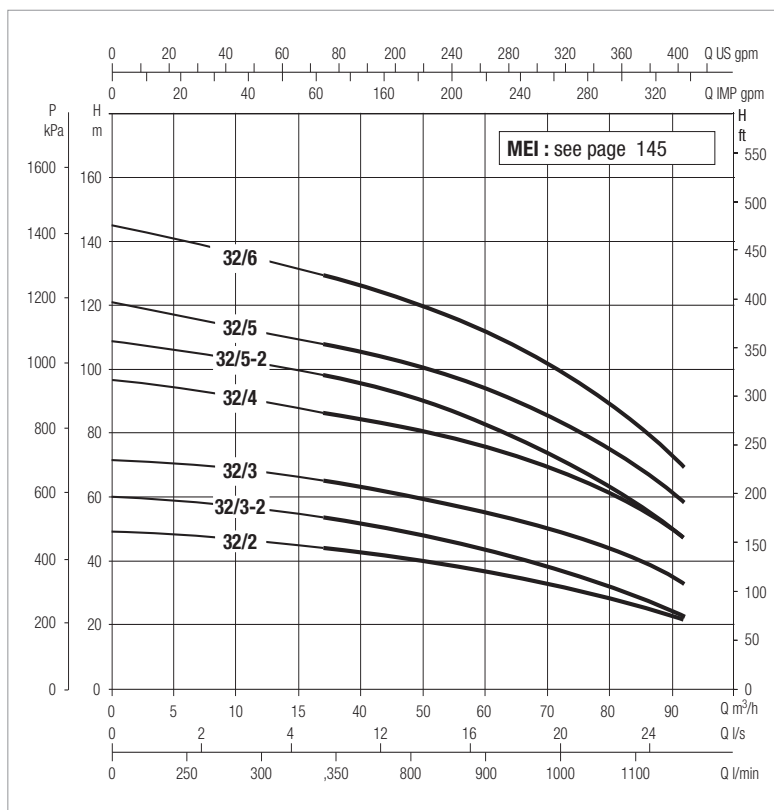
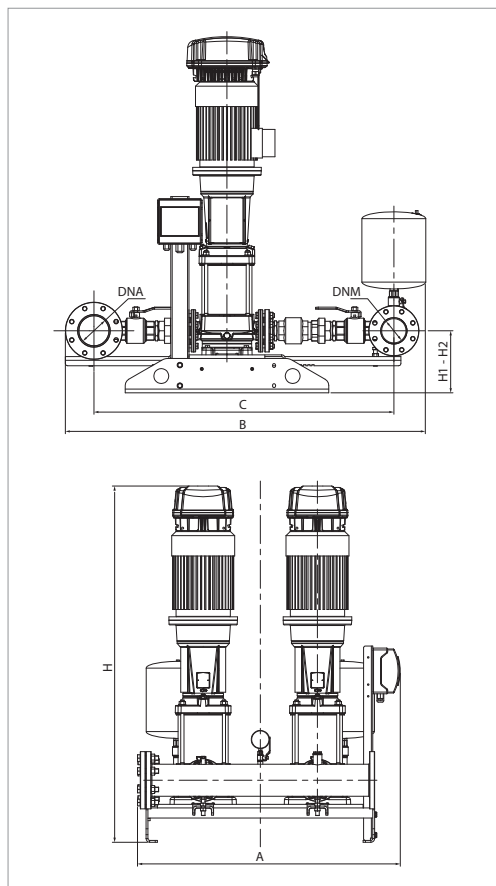

The performance curves are based on kinematic viscosity values = 1 mm<sup>2</sup>/s and density equal to 1000 kg/m<sup>3</sup>.  
Curve tolerance according to ISO 9906.

Overall performance taking into account TWO pumps working at the same time.

MODEL	PUMP+INVERTER POWER INPUT	P2 NOMINAL		In A	MCE/P MODEL	MAXIMUM FLOW RATE m <sup>3</sup> /h	MAX OBTAINABLE PRESSURE BAR	STANDARD PRESSURE BAR
		KW	HP					
2 NKVE 32/2 T MCE 400-50	3x400 50-60Hz	2x5,5	2x7,5	2x13,1	MCE55/P	90	4.8	4
2 NKVE 32/3-2 T MCE 400-50	3x400 50-60Hz	2x5,5	2x7,5	2x13,1	MCE55/P	90	6.0	5
2 NKVE 32/3 T MCE 400-50	3x400 50-60Hz	2x7,5	2x10	2x17,6	MCE110/P	90	7.3	6
2 NKVE 32/4 T MCE 400-50	3x400 50-60Hz	2x11	2x15	2x25,5	MCE110/P	90	9.8	8
2 NKVE 32/5-2 T MCE 400-50	3x400 50-60Hz	2x11	2x15	2x25,5	MCE110/P	90	10.9	9
2 NKVE 32/5 T MCE 400-50	3x400 50-60Hz	2x15	2x20	2x34	MCE150/P	90	12.2	10
2 NKVE 32/6 T MCE 400-50	3x400 50-60Hz	2x15	2x20	2x34	MCE150/P	90	14.6	12

MODEL	A	B	C	H	H1	H2	DNA	DNM	PACKING DIMENSIONS			WEIGHT kg
									L/A	L/B	H	
2 NKVE 32/2 T MCE 400-50	1150	1575	1312	1476	271	271	150	125	1400	1800	2200	476
2 NKVE 32/3-2 T MCE 400-50	1150	1575	1312	1558	271	271	150	125	1400	1800	2200	484
2 NKVE 32/3 T MCE 400-50	1150	1575	1312	1558	271	271	150	125	1400	1800	2200	506
2 NKVE 32/4 T MCE 400-50	1150	1575	1312	1829	271	271	150	125	1400	1800	2200	616
2 NKVE 32/5-2 T MCE 400-50	1150	1575	1312	1911	271	271	150	125	1400	1800	2200	624
2 NKVE 32/5 T MCE 400-50	1150	1575	1312	1911	271	271	150	125	1400	1800	2200	652
2 NKVE 32/6 T MCE 400-50	1150	1575	1312	1993	271	271	150	125	1400	1800	2200	660

## 2 NKVE 45 - MCE/P - CONSTANT PRESSURE BOOSTER SETS

Pumped liquid temperature range: from -15 °C to +80 °C - Maximum ambient temperature: +40 °C - Max flow rate: 140 m<sup>3</sup>/h

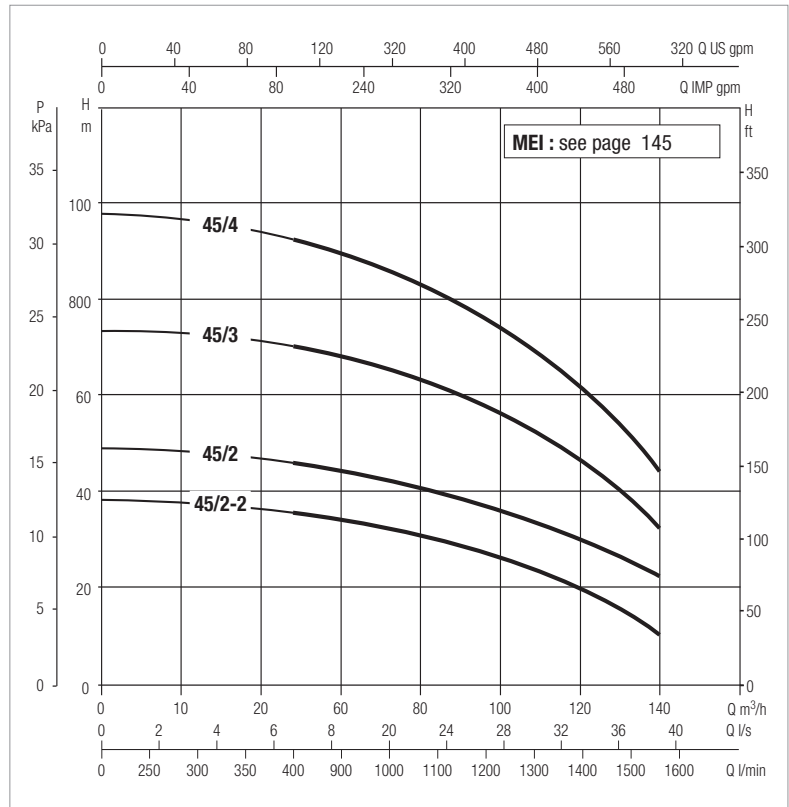
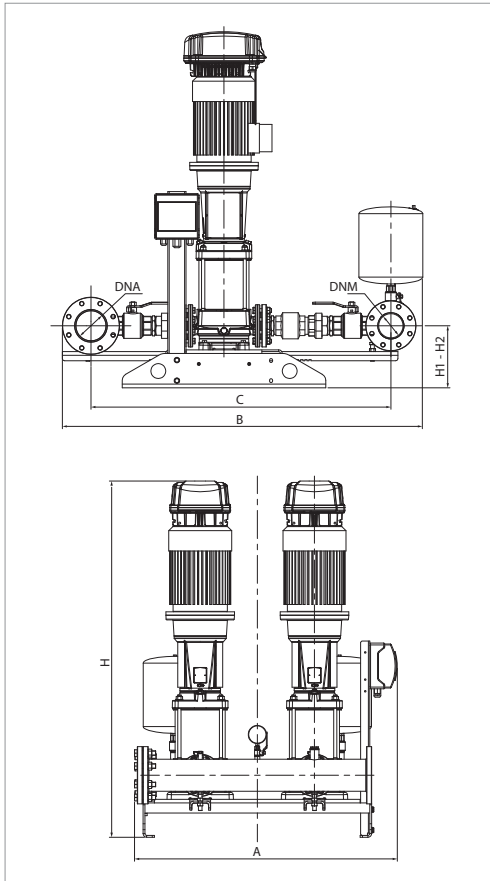

The performance curves are based on kinematic viscosity values = 1 mm<sup>2</sup>/s and density equal to 1000 kg/m<sup>3</sup>.  
Curve tolerance according to ISO 9906.

Overall performance taking into account TWO pumps working at the same time.

MODEL	PUMP+INVERTER POWER INPUT	P2 NOMINAL		In A	MCE/P MODEL	MAXIMUM FLOW RATE m <sup>3</sup> /h	MAX OBTAINABLE PRESSURE BAR	STANDARD PRESSURE BAR
		KW	HP					
2 NKVE 45/2-2 T MCE 400-50	3x400 50-60Hz	2x5,5	2x7,5	2x13,1	MCE55/P	140	3.8	3
2 NKVE 45/2 T MCE 400-50	3x400 50-60Hz	2x7,5	2x10	2x17,6	MCE110/P	140	4.8	4
2 NKVE 45/3 T MCE 400-50	3x400 50-60Hz	2x11	2x15	2x25,5	MCE110/P	140	7.3	6.5
2 NKVE 45/4 T MCE 400-50	3x400 50-60Hz	2x15	2x20	2x34	MCE150/P	140	9.7	8.5

MODEL	A	B	C	H	H1	H2	DNA	DNM	PACKING DIMENSIONS			WEIGHT kg
									L/A	L/B	H	
2 NKVE 45/2-2 T MCE 400-50	1150	1622	1340	1515	271	271	150	125	1400	1800	2200	488
2 NKVE 45/2 T MCE 400-50	115	1622	1340	1565	271	271	150	125	1400	1800	2200	510
2 NKVE 45/3 T MCE 400-50	1150	1622	1340	1782	271	271	150	125	1400	1800	2200	620
2 NKVE 45/4 T MCE 400-50	1150	1622	1340	1864	271	271	150	125	1400	1800	2200	656

### 3 NKVE 10 - MCE/P - CONSTANT PRESSURE BOOSTER SETS

Pumped liquid temperature range: from -15 °C to +80 °C - Maximum ambient temperature: +40 °C - Max flow rate: 39 m<sup>3</sup>/h

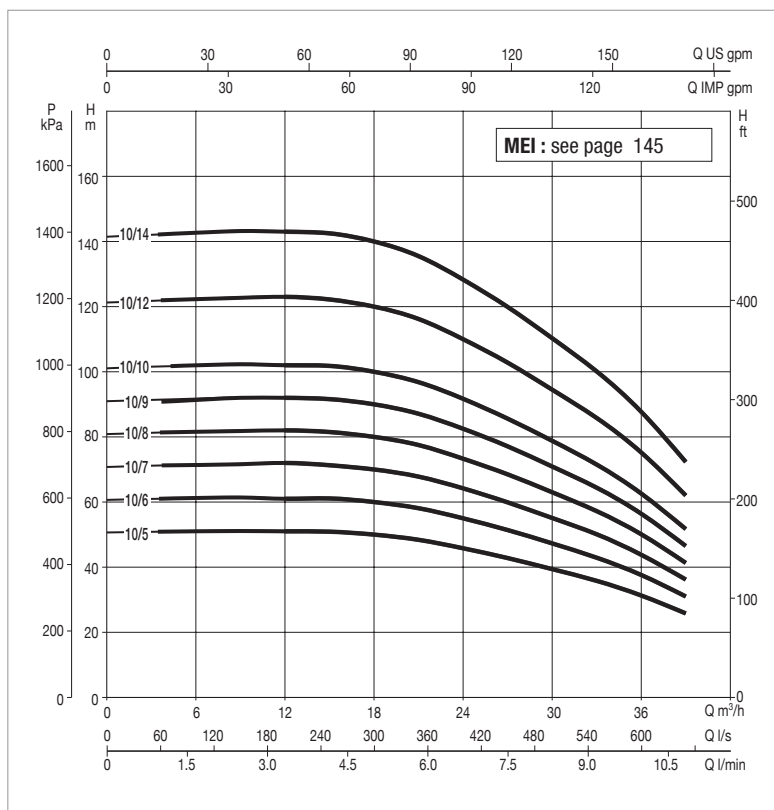
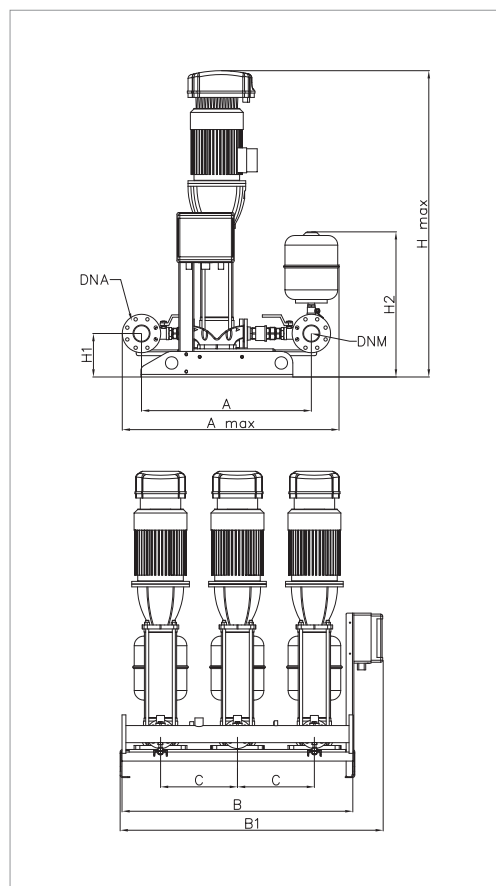

The performance curves are based on kinematic viscosity values = 1 mm<sup>2</sup>/s and density equal to 1000 kg/m<sup>3</sup>.  
Curve tolerance according to ISO 9906.

Overall performance taking into account THREE pumps working at the same time.

MODEL	PUMP+INVERTER POWER INPUT	P2 NOMINAL		In A	MCE/P MODEL	MAXIMUM FLOW RATE m <sup>3</sup> /h	MAX OBTAINABLE PRESSURE BAR	STANDARD PRESSURE BAR
		KW	HP					
3 NKVE 10/5 T MCE30/P	3 x 400V 50Hz	3x2.2	3x3	3x4.9	MCE30/P	39	5	4.0
3 NKVE 10/6 T MCE30/P	3 x 400V 50Hz	3x2.2	3x3	3x5.4	MCE30/P	39	6	5.0
3 NKVE 10/7 T MCE30/P	3 x 400V 50Hz	3x3	3x4	3x7.37	MCE30/P	39	7	6
3 NKVE 10/8 T MCE30/P	3 x 400V 50Hz	3x3	3x4	3x7.37	MCE30/P	39	8	6.5
3 NKVE 10/9 T MCE30/P	3 x 400V 50Hz	3x3	3x4	3x7.37	MCE30/P	39	9	7.7
3 NKVE 10/10 T MCE55/P	3 x 400V 50Hz	3x4	3x5.5	3x10.1	MCE55/P	39	10	8.5
3 NKVE 10/12 T MCE55/P	3 x 400V 50Hz	3x4	2x5.5	3x10.1	MCE55/P	39	12	10
3 NKVE 10/14 T MCE55/P	3 x 400V 50Hz	3x5.5	3x7.5	3x13.1	MCE55/P	39	14	10

MODEL	A	A MAX	B	B1	C	H1	H2	H MAX	DNA	DNM	PACKING DIMENSIONS			WEIGHT kg
											L/A	L/B	H	
3 NKVE 10/5 T MCE30/P	9.417	1130	1200	1370	400	226	755	1109	80	80	2150	1400	1800	425
3 NKVE 10/6 T MCE30/P	885	1130	1200	1370	400	226	755	1142	80	80	2150	1400	1800	428
3 NKVE 10/7 T MCE30/P	885	1130	1200	1370	400	226	755	1221	80	80	2150	1400	1800	468
3 NKVE 10/8 T MCE30/P	885	1130	1200	1370	400	226	755	1254	80	80	2150	1400	1800	471
3 NKVE 10/9 T MCE30/P	885	1130	1200	1370	400	226	755	1287	80	80	2150	1400	1800	473
3 NKVE 10/10 T MCE55/P	885	1130	1200	1370	400	226	755	1335	80	80	2150	1400	1800	503
3 NKVE 10/12 T MCE55/P	885	1130	1200	1370	400	226	755	1401	80	80	2150	1400	1800	508
3 NKVE 10/14 T MCE55/P	885	1130	1200	1370	400	226	755	1597	80	80	2150	1400	1800	593

### 3 NKVE 15 - MCE/P - CONSTANT PRESSURE BOOSTER SETS

Pumped liquid temperature range: from -15 °C to +80 °C - Maximum ambient temperature: +40 °C - Max flow rate: 72 m<sup>3</sup>/h

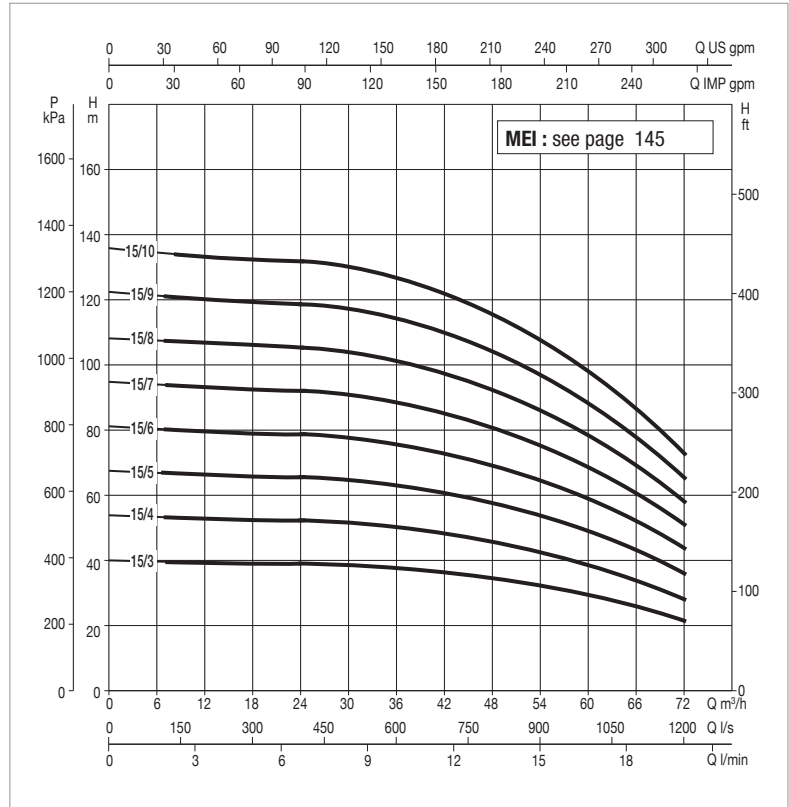
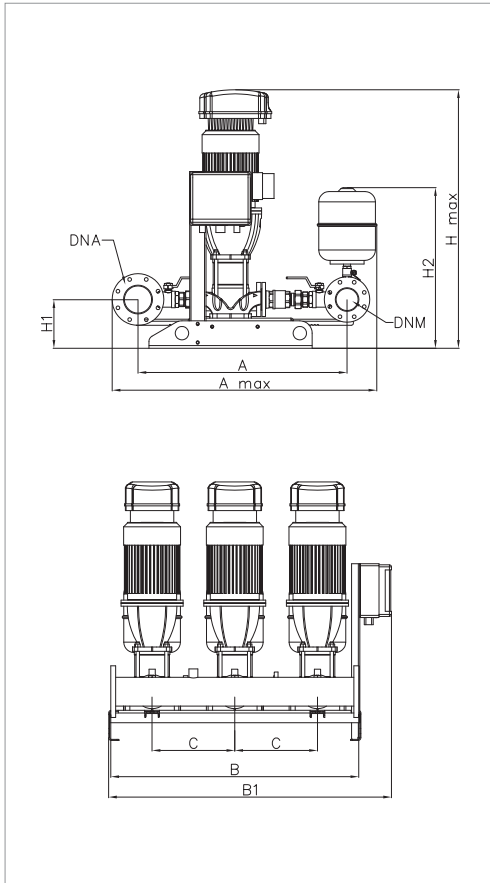

The performance curves are based on kinematic viscosity values = 1 mm<sup>2</sup>/s and density equal to 1000 kg/m<sup>3</sup>.  
Curve tolerance according to ISO 9906.

Overall performance taking into account THREE pumps working at the same time.

MODEL	PUMP+INVERTER POWER INPUT	P2 NOMINAL		In A	MCE/P MODEL	MAXIMUM FLOW RATE m <sup>3</sup> /h	MAX OBTAINABLE PRESSURE BAR	STANDARD PRESSURE BAR
		KW	HP					
3 NKVE 15/3 T MCE30/P	3 x 400V 50Hz	3x3	3x4	3x7.37	MCE30/P	72	4	3.5
3 NKVE 15/4 T MCE55/P	3 x 400V 50Hz	3x4	3x5.5	3x10.1	MCE55/P	72	5	4
3 NKVE 15/5 T MCE55/P	3 x 400V 50Hz	3x4	3x5.5	3x10.1	MCE55/P	72	6.5	5
3 NKVE 15/6 T MCE55/P	3 x 400V 50Hz	3x5.5	3x7.5	3x13.1	MCE55/P	72	7.5	6.5
3 NKVE 15/7 T MCE55/P	3 x 400V 50Hz	3x5.5	3x7.5	3x13.1	MCE55/P	72	9	8
3 NKVE 15/8 T MCE110/P	3 x 400V 50Hz	3x7.5	3x10	3x17.6	MCE110/P	72	11	10
3 NKVE 15/9 T MCE110/P	3 x 400V 50Hz	3x7.5	3x10	3x17.6	MCE110/P	72	12	11
3 NKVE 15/10 T MCE110/P	3 x 400V 50Hz	3x11	3x15	3x25.5	MCE110/P	72	13	12

MODEL	A	A MAX	B	B1	C	H1	H2	H MAX	DNA	DNM	PACKING DIMENSIONS			WEIGHT kg
											L/A	L/B	H	
3 NKVE 15/3 T MCE30/P	1115	1285	1200	1370	400	236	780	1160	125	100	2150	1400	1800	486
3 NKVE 15/4 T MCE55/P	1115	1285	1200	1370	400	236	780	1225	125	100	2150	1400	1800	516
3 NKVE 15/5 T MCE55/P	1115	1285	1200	1370	400	236	780	1274	125	100	2150	1400	1800	520
3 NKVE 15/6 T MCE55/P	1115	1285	1200	1370	400	236	780	1453	125	100	2150	1400	1800	605
3 NKVE 15/7 T MCE55/P	1115	1285	1200	1370	400	236	780	1503	125	100	2150	1400	1800	608
3 NKVE 15/8 T MCE110/P	1115	1285	1200	1370	400	236	780	1602	125	100	2150	1400	1800	645
3 NKVE 15/9 T MCE110/P	1115	1285	1200	1370	400	236	780	1652	125	100	2150	1400	1800	649
3 NKVE 15/10 T MCE110/P	1115	1285	1200	1370	400	236	780	1846	125	100	2150	1400	1800	818



### 3 NKVE 20 - MCE/P - CONSTANT PRESSURE BOOSTER SETS

Pumped liquid temperature range: from -15 °C to +80 °C - Maximum ambient temperature: +40 °C - Max flow rate: 87 m<sup>3</sup>/h

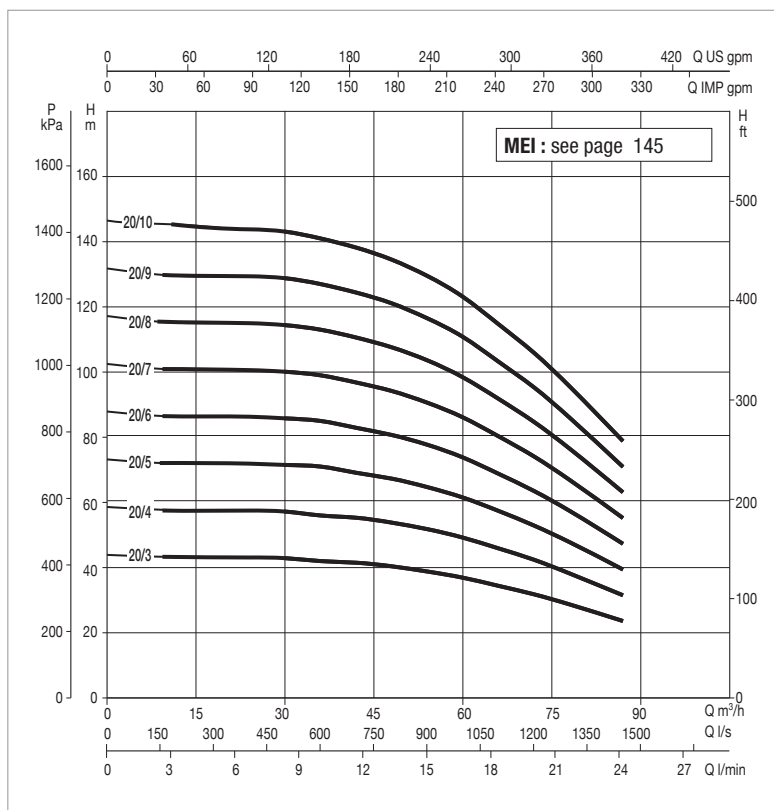
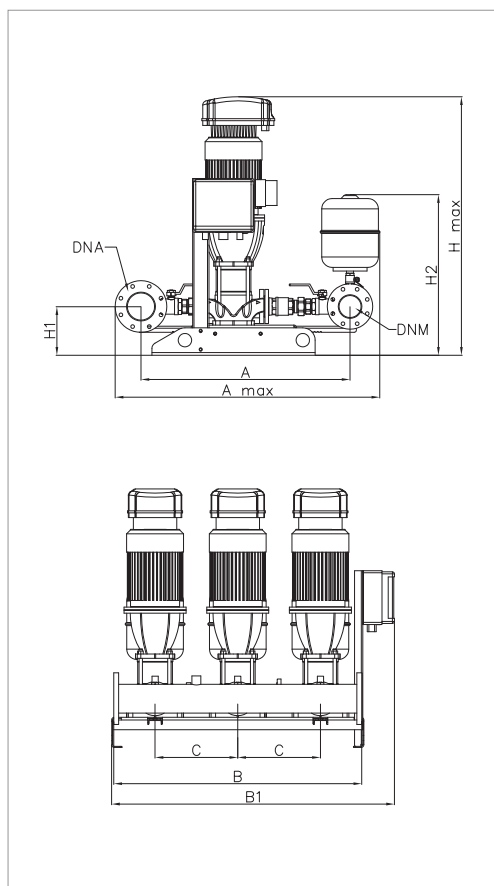

The performance curves are based on kinematic viscosity values = 1 mm<sup>2</sup>/s and density equal to 1000 kg/m<sup>3</sup>.  
Curve tolerance according to ISO 9906.

Overall performance taking into account THREE pumps working at the same time.

MODEL	PUMP+INVERTER POWER INPUT	P2 NOMINAL		In [A]	MCE/P MODEL	MAXIMUM FLOW RATE m <sup>3</sup> /h	MAX OBTAINABLE PRESSURE BAR	STANDARD PRESSURE BAR
		[KW]	[HP]					
3 NKVE 20/3 T MCE55/P	3 x 400V 50Hz	3x4	3x5.5	3x10.1	MCE55/P	87	4	3.5
3 NKVE 20/4 T MCE55/P	3 x 400V 50Hz	3x5.5	3x7.5	3x13.1	MCE55/P	87	6	5
3 NKVE 20/5 T MCE55/P	3 x 400V 50Hz	3x5.5	3x7.5	3x13.1	MCE55/P	87	7	6
3 NKVE 20/6 T MCE110/P	3 x 400V 50Hz	3x7.5	3x10	3x17.6	MCE110/P	87	8.5	7.5
3 NKVE 20/7 T MCE110/P	3 x 400V 50Hz	3x7.5	3x10	3x17.6	MCE110/P	87	10	9
3 NKVE 20/8 T MCE110/P	3 x 400V 50Hz	3x11	3x15	3x25.5	MCE110/P	87	11.5	10
3 NKVE 20/9 T MCE110/P	3 x 400V 50Hz	3x11	3x15	3x25.5	MCE110/P	87	13	12
3 NKVE 20/10 T MCE110/P	3 x 400V 50Hz	3x11	3x15	3x25.5	MCE110/P	87	14	13

MODEL	A	A MAX	B	B1	C	H1	H2	H MAX	DNA	DNM	PACKING DIMENSIONS			WEIGHT kg
											L/A	L/B	H	
3 NKVE 20/3 T MCE55/P	1115	1285	1200	1370	400	236	780	1175	125	100	2150	1400	1800	471
3 NKVE 20/4 T MCE55/P	1115	1285	1200	1370	400	236	780	1354	125	100	2150	1400	1800	513
3 NKVE 20/5 T MCE55/P	1115	1285	1200	1370	400	236	780	1404	125	100	2150	1400	1800	519
3 NKVE 20/6 T MCE110/P	1115	1285	1200	1370	400	236	780	1503	125	100	2150	1400	1800	556
3 NKVE 20/7 T MCE110/P	1115	1285	1200	1370	400	236	780	1553	125	100	2150	1400	1800	559
3 NKVE 20/8 T MCE110/P	1115	1285	1200	1370	400	236	780	1747	125	100	2150	1400	1800	655
3 NKVE 20/9 T MCE110/P	1115	1285	1200	1370	400	236	780	1796	125	100	2150	1400	1800	658
3 NKVE 20/10 T MCE110/P	1115	1285	1200	1370	400	236	780	1846	125	100	2150	1400	1800	691

### 3 NKVE 32 -MCE/P - CONSTANT PRESSURE BOOSTER SETS

Pumped liquid temperature range: from -15 °C to +80 °C - Maximum ambient temperature: +40 °C - Max flow rate: 135 m³/h

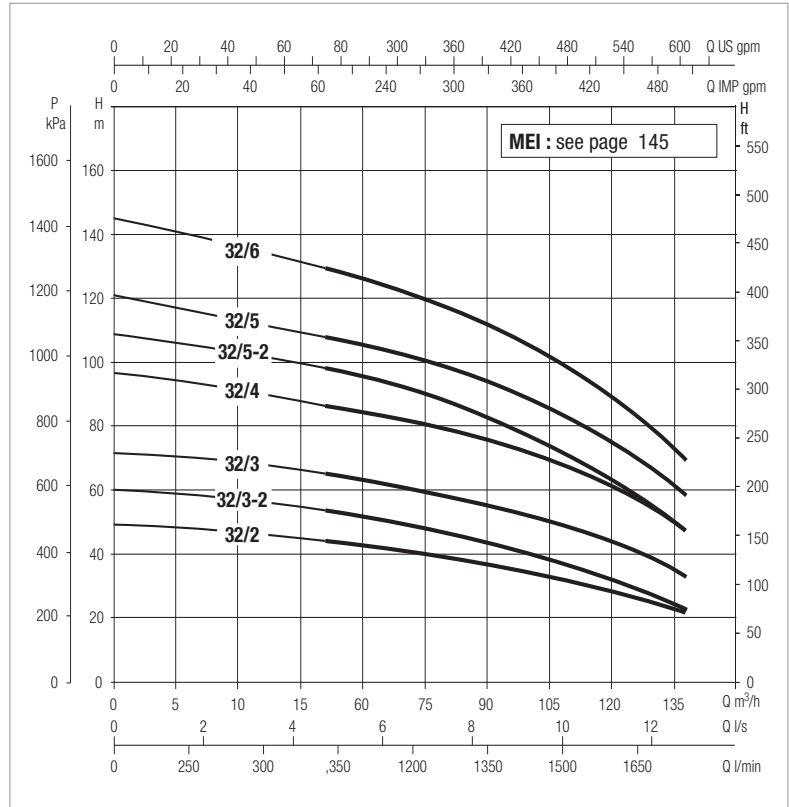
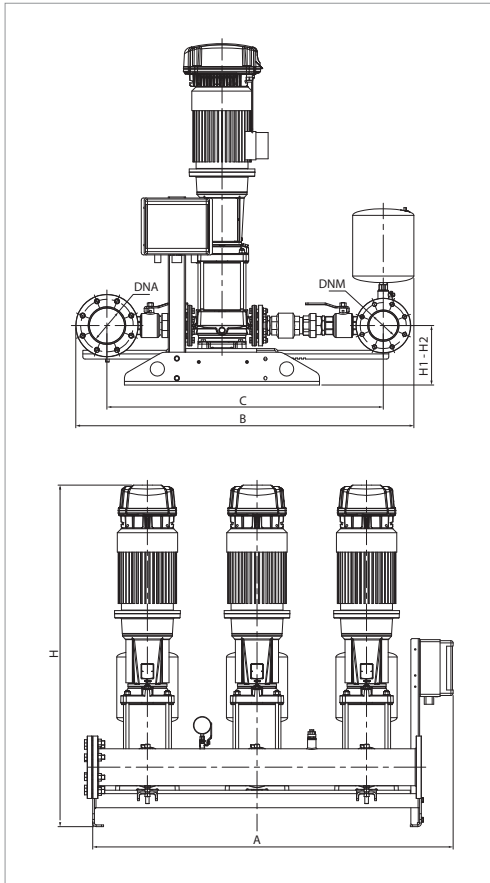

The performance curves are based on kinematic viscosity values = 1 mm²/s and density equal to 1000 kg/m³.  
Curve tolerance according to ISO 9906.

Overall performance taking into account THREE pumps working at the same time.

MODEL	PUMP+INVERTER POWER INPUT	P2 NOMINAL		In A	MCE/P MODEL	MAXIMUM FLOW RATE m³/h	MAX OBTAINABLE PRESSURE BAR	STANDARD PRESSURE BAR
		KW	HP					
3 NKVE 32/2 T MCE 400-50	3x400 50-60Hz	2x5,5	2x7,5	2x13,1	MCE55/P	135	4.8	4
3 NKVE 32/3-2 T MCE 400-50	3x400 50-60Hz	2x5,5	2x7,5	2x13,1	MCE55/P	135	6.0	5
3 NKVE 32/3 T MCE 400-50	3 x 400V 50Hz	2x7,5	2x10	2x17,6	MCE110/P	135	7.3	6
3 NKVE 32/4 T MCE 400-50	3 x 400V 50Hz	2x11	2x15	2x25,5	MCE110/P	135	9.8	8
3 NKVE 32/5-2 T MCE 400-50	3 x 400V 50Hz	2x11	2x15	2x25,5	MCE110/P	135	10.9	9
3 NKVE 32/5 T MCE 400-50	3x400 50-60Hz	2x15	2x20	2x34	MCE150/P	135	12.2	10
3 NKVE 32/6 T MCE 400-50	3x400 50-60Hz	2x15	2x20	2x34	MCE150/P	135	14.6	12

MODEL	A	B	C	H	H1	H2	DNA	DNM	PACKING DIMENSIONS			WEIGHT kg
									L/A	L/B	H	
3 NKVE 32/2 T MCE 400-50	1683	1575	1312	1476	271	271	150	125	1500	2250	2200	714
3 NKVE 32/3-2 T MCE 400-50	1683	1575	1312	1558	271	271	150	125	1500	2250	2200	726
3 NKVE 32/3 T MCE 400-50	1683	1575	1312	1558	271	271	150	125	1500	2250	2200	759
3 NKVE 32/4 T MCE 400-50	1683	1575	1312	1829	271	271	150	125	1500	2250	2200	924
3 NKVE 32/5-2 T MCE 400-50	1683	1575	1312	1911	271	271	150	125	1500	2250	2200	936
3 NKVE 32/5 T MCE 400-50	1683	1575	1312	1911	271	271	150	125	1500	2250	2200	978
3 NKVE 32/6 T MCE 400-50	1683	1575	1312	1993	271	271	150	125	1500	2250	2200	990

### 3 NKVE 45 -MCE/P - CONSTANT PRESSURE BOOSTER SETS

Pumped liquid temperature range: from -15 °C to +80 °C - Maximum ambient temperature: +40 °C - Max flow rate: 210 m<sup>3</sup>/h

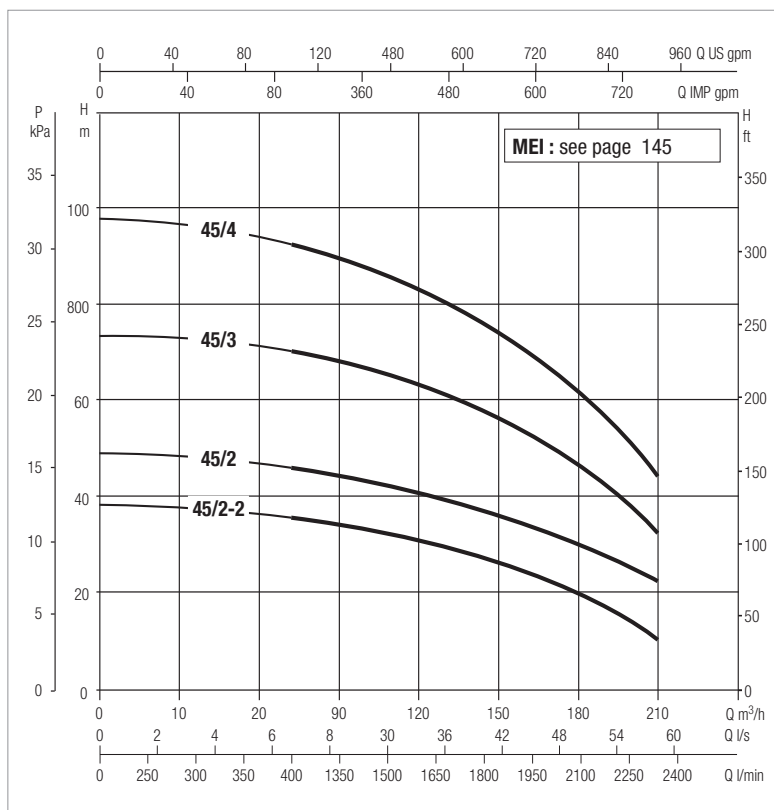
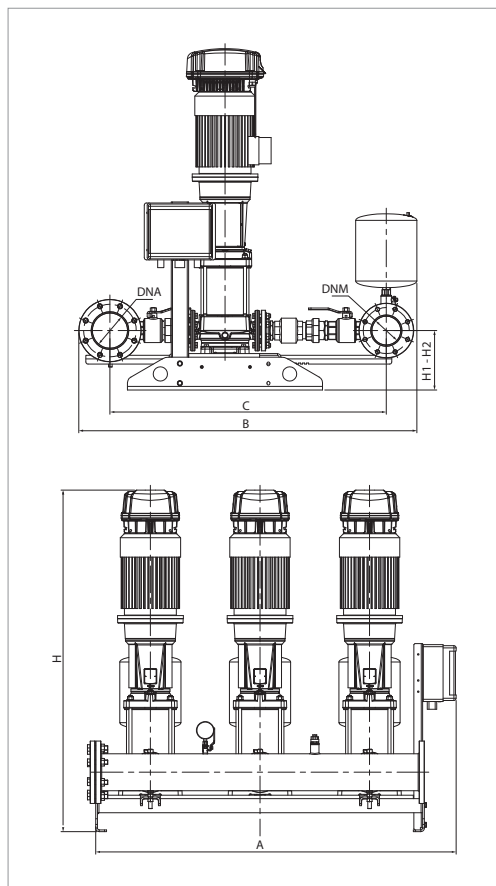

The performance curves are based on kinematic viscosity values = 1 mm<sup>2</sup>/s and density equal to 1000 kg/m<sup>3</sup>.  
Curve tolerance according to ISO 9906.

Overall performance taking into account THREE pumps working at the same time.

MODEL	PUMP+INVERTER POWER INPUT	P2 NOMINAL		In A	MCE/P MODEL	MAXIMUM FLOW RATE m <sup>3</sup> /h	MAX OBTAINABLE PRESSURE BAR	STANDARD PRESSURE BAR
		kW	HP					
3 NKVE 45/2-2 T MCE 400-50	3x400 50-60Hz	2x5,5	2x7,5	2x13,1	MCE55/P	210	3.8	3
3 NKVE 45/2 T MCE 400-50	3x400 50-60Hz	2x7,5	2x10	2x17,6	MCE110/P	210	4.8	4
3 NKVE 45/3 T MCE 400-50	3 x 400V 50Hz	2x11	2x15	2x25,5	MCE110/P	210	7.3	6.5
3 NKVE 45/4 T MCE 400-50	3x400 50-60Hz	2x15	2x20	2x34	MCE150/P	210	9.7	8.5

MODEL	A	B	C	H	H1	H2	DNA	DNM	PACKING DIMENSIONS			WEIGHT kg
									L/A	L/B	H	
3 NKVE 45/2-2 T MCE 400-50	1683	1622	1340	1515	306	306	200	150	1500	2250	2200	732
3 NKVE 45/2 T MCE 400-50	1683	1622	1340	1565	306	306	200	150	1500	2250	2200	765
3 NKVE 45/3 T MCE 400-50	1683	1622	1340	1782	306	306	200	150	1500	2250	2200	930
3 NKVE 45/4 T MCE 400-50	1683	1622	1340	1864	306	306	200	150	1500	2250	2200	984

## 4 NKVE 10 -MCE/P - CONSTANT PRESSURE BOOSTER SETS

Pumped liquid temperature range: from -15 °C to +80 °C - Maximum ambient temperature: +40 °C - Max flow rate: 52 m<sup>3</sup>/h

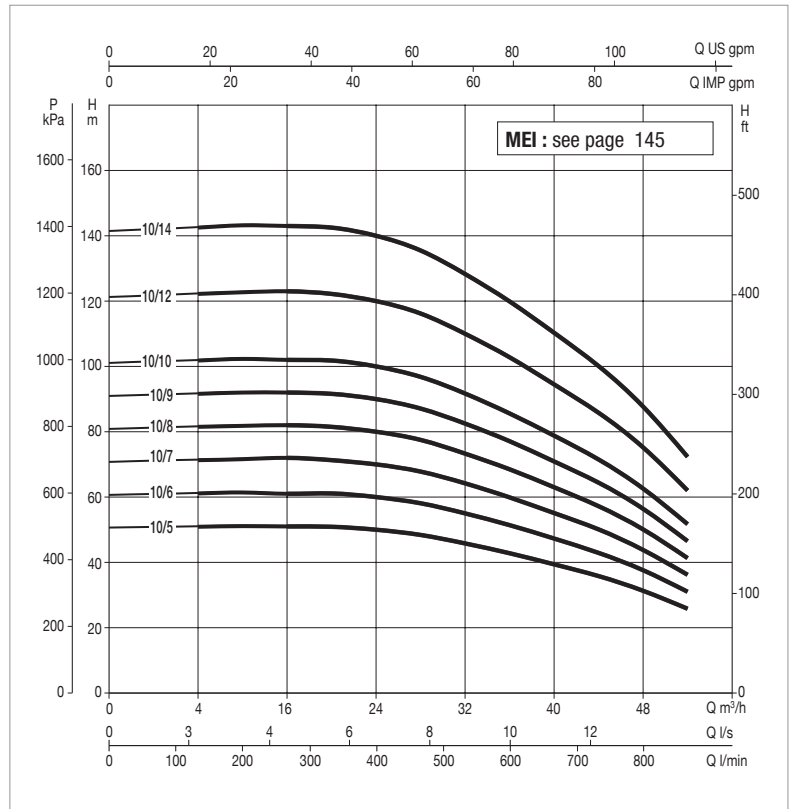
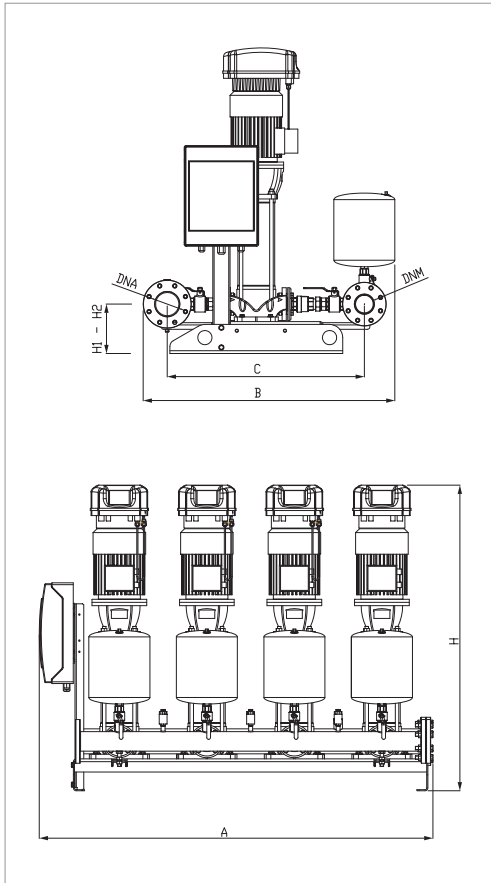

The performance curves are based on kinematic viscosity values = 1 mm<sup>2</sup>/s and density equal to 1000 kg/m<sup>3</sup>.  
Curve tolerance according to ISO 9906.

Overall performance taking into account FOUR pumps working at the same time.

MODEL	PUMP+INVERTER POWER INPUT	P2 NOMINAL		In A	MCE/P MODEL	MAXIMUM FLOW RATE m <sup>3</sup> /h	MAX OBTAINABLE PRESSURE BAR	STANDARD PRESSURE BAR
		KW	HP					
4 NKVE 10/5 T MCE 400-50	3 x 400V 50Hz	4x2.2	4x3	4x4.9	MCE30/P	52	5	4
4 NKVE 10/6 T MCE 400-50	3 x 400V 50Hz	4x2.2	4x3	4x5.4	MCE30/P	52	6	5
4 NKVE 10/7 T MCE 400-50	3 x 400V 50Hz	4x3	4x4	4x7.37	MCE30/P	52	7	6
4 NKVE 10/8 T MCE 400-50	3 x 400V 50Hz	4x3	4x4	4x7.37	MCE30/P	52	8	6.5
4 NKVE 10/9 T MCE 400-50	3 x 400V 50Hz	4x3	4x4	4x7.37	MCE30/P	52	9	7.7
4 NKVE 10/10 T MCE 400-50	3 x 400V 50Hz	4x4	4x5.5	4x10.1	MCE55/P	52	10	8.5
4 NKVE 10/12 T MCE 400-50	3 x 400V 50Hz	4x4	4x5.5	4x10.1	MCE55/P	52	12	10

MODEL	A	B	C	H	H1	H2	H MAX	DNA	DNM	PACKING DIMENSIONS			WEIGHT kg
										L/A	L/B	H	
4 NKVE 10/5 T MCE 400-50	1800	1150	900	1108	226	226	1109	100	80	2250	1500	2200	327
4 NKVE 10/6 T MCE 400-50	1800	1150	900	1141	226	226	1142	100	80	2250	1500	2200	571
4 NKVE 10/7 T MCE 400-50	1800	1150	900	1221	226	226	1221	100	80	2250	1500	2200	624
4 NKVE 10/8 T MCE 400-50	1800	1150	900	1254	226	226	1254	100	80	2250	1500	2200	628
4 NKVE 10/9 T MCE 400-50	1800	1150	900	1287	226	226	1287	100	80	2250	1500	2200	631
4 NKVE 10/10 T MCE 400-50	1800	1150	900	1335	226	226	1335	100	80	2250	1500	2200	671
4 NKVE 10/12 T MCE 400-50	1800	1150	900	1401	226	226	1401	100	80	2250	1500	2200	678

## 4 NKVE 15 - MCE/P - CONSTANT PRESSURE BOOSTER SETS

Pumped liquid temperature range: from -15 °C to +80 °C - Maximum ambient temperature: +40 °C - Max flow rate: 96 m<sup>3</sup>/h

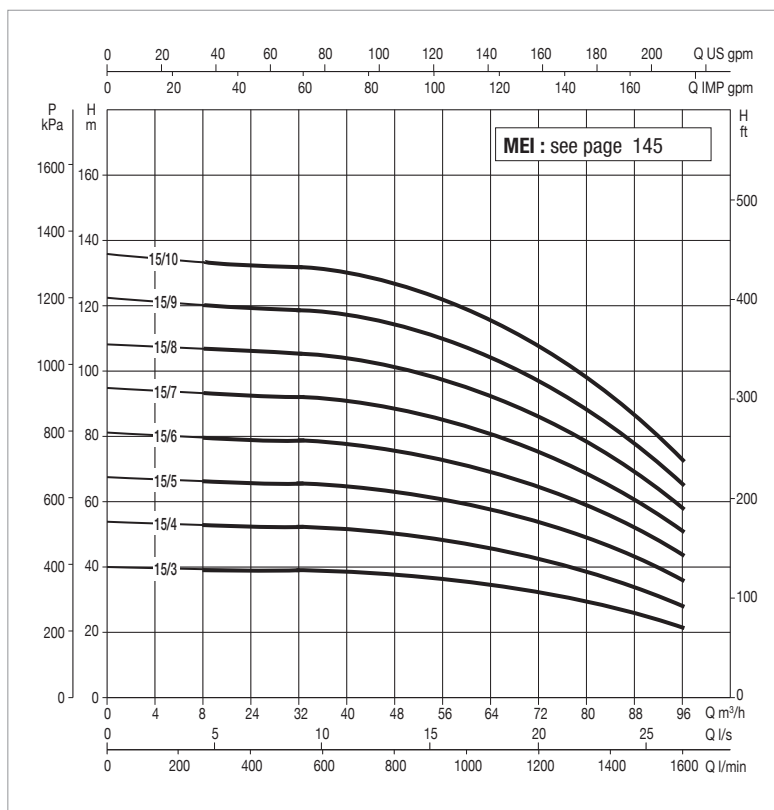
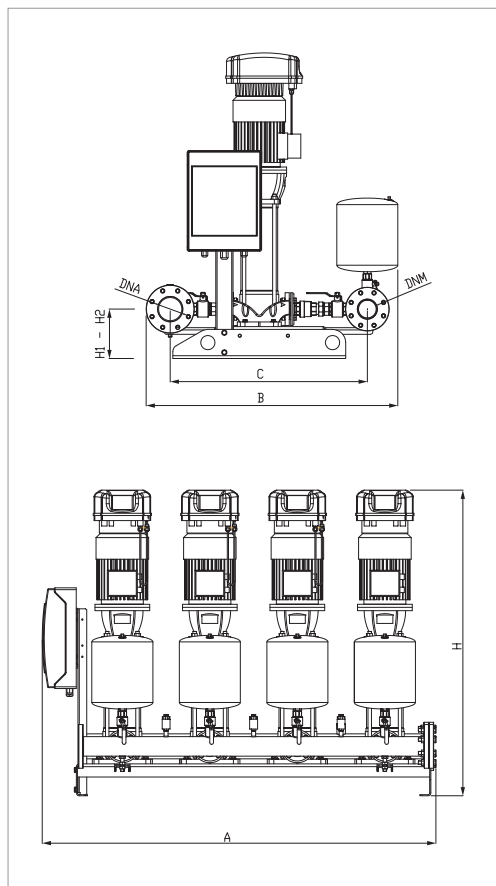

The performance curves are based on kinematic viscosity values = 1 mm<sup>2</sup>/s and density equal to 1000 kg/m<sup>3</sup>.  
Curve tolerance according to ISO 9906.

Overall performance taking into account FOUR pumps working at the same time.

MODEL	PUMP+INVERTER POWER INPUT	P2 NOMINAL		In A	MCE/P MODEL	MAXIMUM FLOW RATE m <sup>3</sup> /h	MAX OBTAINABLE PRESSURE BAR	STANDARD PRESSURE BAR
		KW	HP					
4 NKVE 15/3 T MCE 400-50	3 x 400V 50Hz	4x3	4x4	4x7.37	MCE30/P	96	4	3.5
4 NKVE 15/4 T MCE 400-50	3 x 400V 50Hz	4x4	4x5.5	4x10.1	MCE55/P	96	5	4
4 NKVE 15/5 T MCE 400-50	3 x 400V 50Hz	4x4	4x5.5	4x10.1	MCE55/P	96	6.5	5
4 NKVE 15/6 T MCE 400-50	3 x 400V 50Hz	4x5.5	4x7.5	4x13.1	MCE55/P	96	7.5	6.5
4 NKVE 15/7 T MCE 400-50	3 x 400V 50Hz	4x5.5	4x7.5	4x13.1	MCE55/P	96	9	8
4 NKVE 15/8 T MCE 400-50	3 x 400V 50Hz	4x7.5	4x10	4x17.6	MCE110/P	96	11	10
4 NKVE 15/9 T MCE 400-50	3 x 400V 50Hz	4x7.5	4x10	4x17.6	MCE110/P	96	12	11
4 NKVE 15/10 T MCE 400-50	3 x 400V 50Hz	4x11	4x15	4x25.5	MCE110/P	96	13	12

MODEL	A	B	C	H	H1	H2	DNA	DNM	PACKING DIMENSIONS			WEIGHT kg
									L/A	L/B	H	
4 NKVE 15/3 T MCE 400-50	1800	1330	1050	1160	236	236	150	125	2150	1000	1400	648
4 NKVE 15/4 T MCE 400-50	1800	1330	1050	1225	236	236	150	125	2150	1000	1400	688
4 NKVE 15/5 T MCE 400-50	1800	1330	1050	1274	236	236	150	125	2150	1000	1400	694
4 NKVE 15/6 T MCE 400-50	1800	1330	1050	1453	236	236	150	125	2150	1000	1400	807
4 NKVE 15/7 T MCE 400-50	1800	1330	1050	1503	236	236	150	125	2150	1000	1400	811
4 NKVE 15/8 T MCE 400-50	1800	1330	1050	1602	236	236	150	125	2150	1000	1400	860
4 NKVE 15/9 T MCE 400-50	1800	1330	1050	1652	236	236	150	125	2150	1000	1400	865
4 NKVE 15/10 T MCE 400-50	1800	1330	1050	1846	236	236	150	125	2150	1000	1400	919

## 4 NKVE 20 - MCE/P - CONSTANT PRESSURE BOOSTER SETS

Pumped liquid temperature range: from -15 °C to +80 °C - Maximum ambient temperature: +40 °C - Max flow rate: 116 m<sup>3</sup>/h

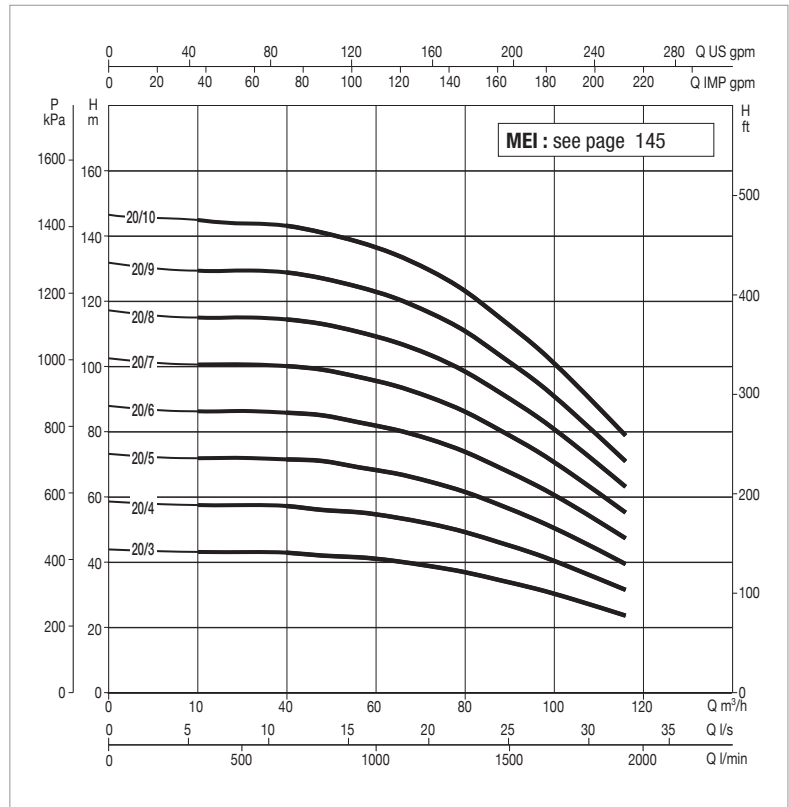
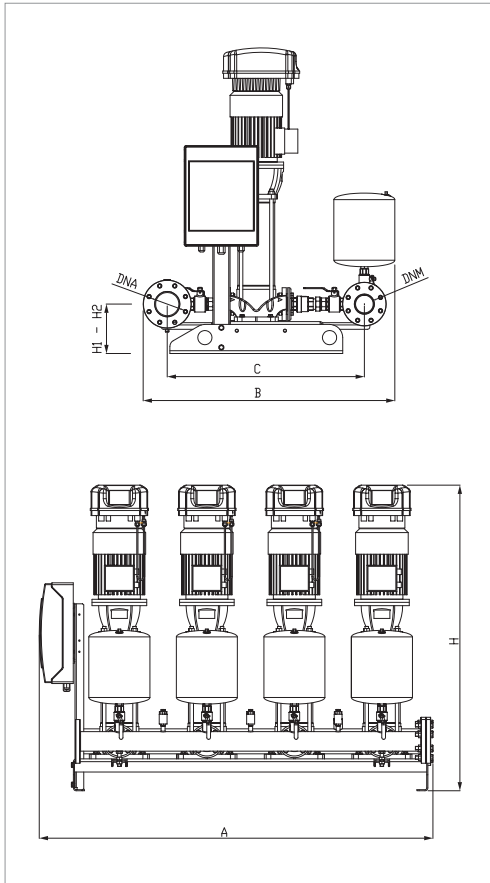

The performance curves are based on kinematic viscosity values = 1 mm<sup>2</sup>/s and density equal to 1000 kg/m<sup>3</sup>.  
Curve tolerance according to ISO 9906.

Overall performance taking into account FOUR pumps working at the same time.

MODEL	PUMP+INVERTER POWER INPUT	P2 NOMINAL		In A	MCE/P MODEL	MAXIMUM FLOW RATE m <sup>3</sup> /h	MAX OBTAINABLE PRESSURE BAR	STANDARD PRESSURE BAR
		KW	HP					
4 NKVE 20/3 T MCE 400-50	3 x 400V 50Hz	4x4	4x5.5	4x10.1	MCE55/P	116	4	3.5
4 NKVE 20/4 T MCE 400-50	3 x 400V 50Hz	4x5.5	4x7.5	4x13.1	MCE55/P	116	6	5
4NKV 20/5 T MCE 400-50	3 x 400V 50Hz	4x5.5	4x7.5	4x13.1	MCE55/P	116	7	6
4NKVE 20/6 T MCE 400-50	3 x 400V 50Hz	4x7.5	4x10	4x17.6	MCE110/P	116	8.5	7.5
4NKVE 20/7 T MCE 400-50	3 x 400V 50Hz	4x7.5	4x10	4x17.6	MCE110/P	116	10	9
4NKVE 20/8 T MCE 400-50	3 x 400V 50Hz	4x11	4x15	4x25.5	MCE110/P	116	11.5	10
4NKVE 20/9 T MCE 400-50	3 x 400V 50Hz	4x11	4x15	4x25.5	MCE110/P	116	13	12
4NKVE 20/10 T MCE 400-50	3 x 400V 50Hz	4x11	4x15	4x25.5	MCE110/P	116	14	13

MODEL	A	B	C	H	H1	H2	DNA	DNM	PACKING DIMENSIONS			WEIGHT kg
									L/A	L/B	H	
4 NKVE 20/3 T MCE 400-50	1800	1330	1150	1175	236	236	150	125	2150	1000	1400	628
4 NKVE 20/4 T MCE 400-50	1800	1330	1150	1354	236	236	150	125	2150	1000	1400	684
4 NKVE 20/5 T MCE 400-50	1800	1330	1150	1404	236	236	150	125	2150	1000	1400	692
4 NKVE 20/6 T MCE 400-50	1800	1330	1150	1503	236	236	150	125	2150	1000	1400	741
4 NKVE 20/7 T MCE 400-50	1800	1330	1150	1553	236	236	150	125	2150	1000	1400	745
4 NKVE 20/8 T MCE 400-50	1800	1330	1150	1747	236	236	150	125	2150	1000	1400	873
4 NKVE 20/9 T MCE 400-50	1800	1330	1150	1796	236	236	150	125	2150	1000	1400	877
4 NKVE 20/10 T MCE 400-50	1800	1330	1150	1846	236	236	150	125	2150	1000	1400	921

## 4 NKVE 32 -MCE/P - CONSTANT PRESSURE BOOSTER SETS

Pumped liquid temperature range: from -15 °C to +80 °C - Maximum ambient temperature: +40 °C - Max flow rate: 180 m<sup>3</sup>/h

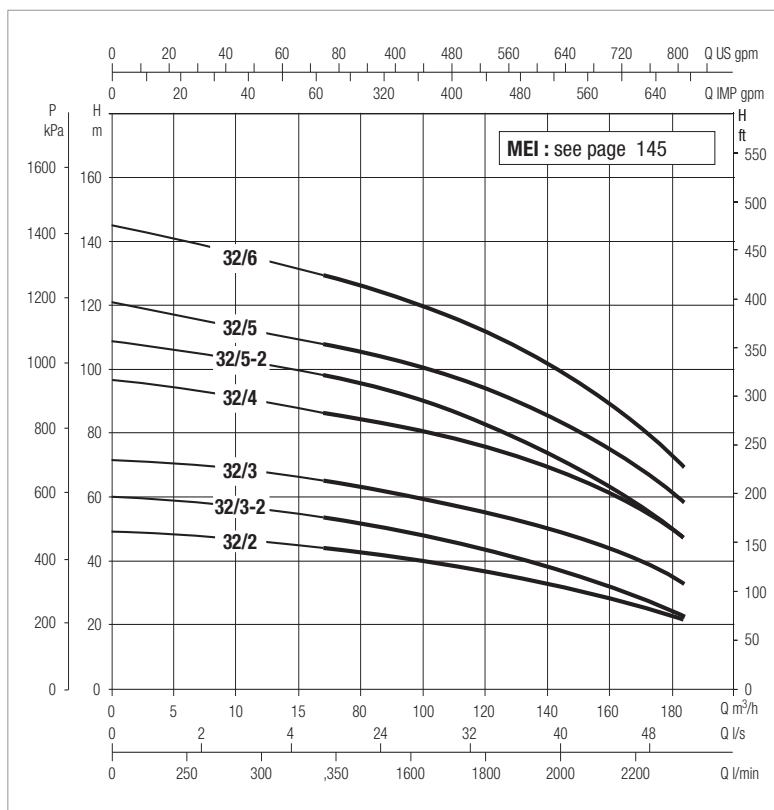
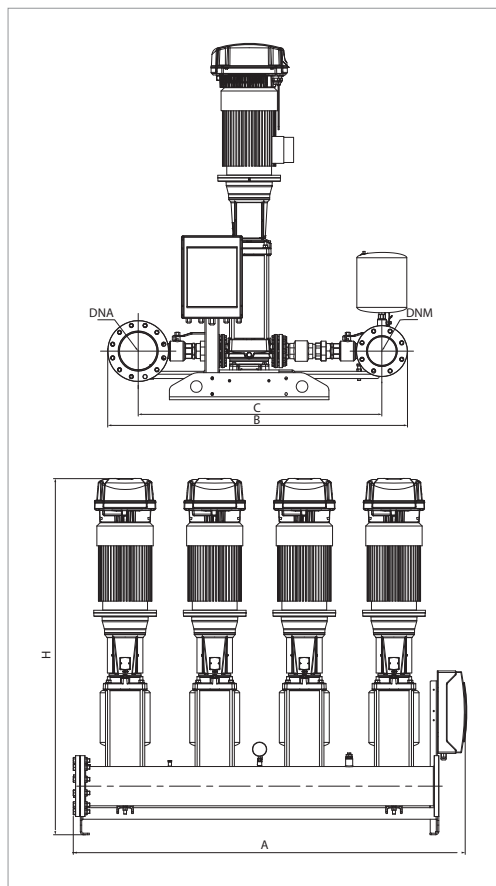

The performance curves are based on kinematic viscosity values = 1 mm<sup>2</sup>/s and density equal to 1000 kg/m<sup>3</sup>.  
Curve tolerance according to ISO 9906.

Overall performance taking into account FOUR pumps working at the same time.

MODEL	PUMP+INVERTER POWER INPUT	P2 NOMINAL		In A	MCE/P MODEL	MAXIMUM FLOW RATE m <sup>3</sup> /h	MAX OBTAINABLE PRESSURE BAR	STANDARD PRESSURE BAR
		KW	HP					
4 NKVE 32/2 T MCE 400-50	3x400 50-60Hz	2x5,5	2x7,5	2x13,1	MCE55/P	180	4.8	4
4 NKVE 32/3-2 T MCE 400-50	3x400 50-60Hz	2x5,5	2x7,5	2x13,1	MCE55/P	180	6.0	5
4 NKVE 32/3 T MCE 400-50	3x400 50-60Hz	2x7,5	2x10	2x17,6	MCE110/P	180	7.3	6
4 NKVE 32/4 T MCE 400-50	3x400 50-60Hz	2x11	2x15	2x25,5	MCE110/P	180	9.8	8
4 NKVE 32/5-2 T MCE 400-50	3x400 50-60Hz	2x11	2x15	2x25,5	MCE110/P	180	10.9	9
4 NKVE 32/5 T MCE 400-50	3x400 50-60Hz	2x15	2x20	2x34	MCE150/P	180	12.2	10
4 NKVE 32/6 T MCE 400-50	3x400 50-60Hz	2x15	2x20	2x34	MCE150/P	180	14.6	12

MODEL	A	B	C	H	H1	H2	DNA	DNM	PACKING DIMENSIONS			WEIGHT kg
									L/A	L/B	H	
4 NKVE 32/2 T MCE 400-50	2195	1672	1340	1476	271	271	200	150	2660	1760	2200	952
4 NKVE 32/3-2 T MCE 400-50	2195	1672	1340	1558	271	271	200	150	2660	1760	2200	968
4 NKVE 32/3 T MCE 400-50	2195	1672	1340	1558	271	271	200	150	2660	1760	2200	1012
4 NKVE 32/4 T MCE 400-50	2195	1672	1340	1829	271	271	200	150	2660	1760	2200	1232
4 NKVE 32/5-2 T MCE 400-50	2195	1672	1340	1911	271	271	200	150	2660	1760	2200	1248
4 NKVE 32/5 T MCE 400-50	2195	1672	1340	1911	271	271	200	150	2660	1760	2200	1304
4 NKVE 32/6 T MCE 400-50	2195	1672	1340	1993	271	271	200	150	2660	1760	2200	1320

## 4 NKVE 45 -MCE/P - CONSTANT PRESSURE BOOSTER SETS

Pumped liquid temperature range: from -15 °C to +80 °C - Maximum ambient temperature: +40 °C - Max flow rate: 280 m³/h

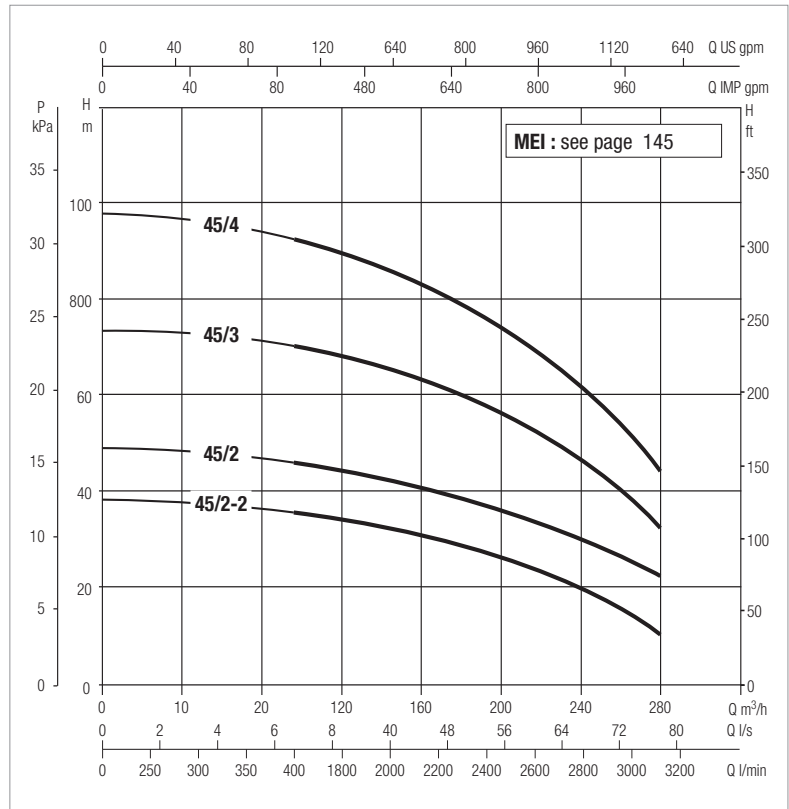
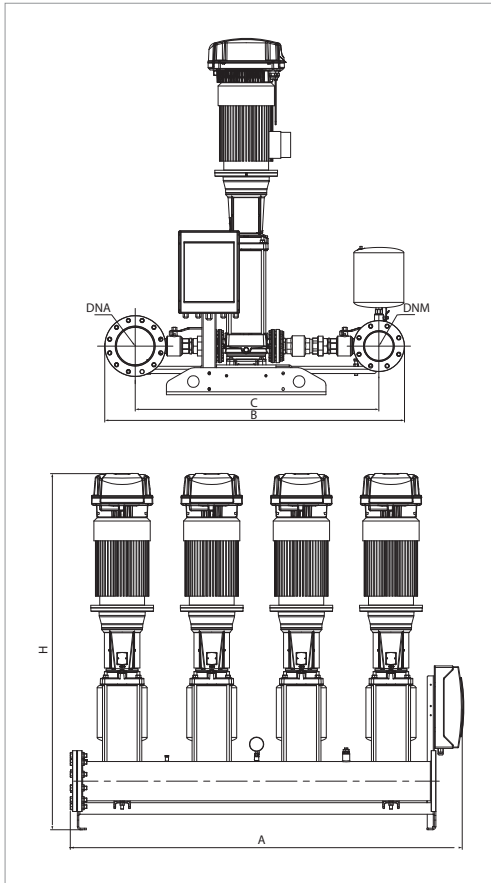

The performance curves are based on kinematic viscosity values = 1 mm²/s and density equal to 1000 kg/m³.  
Curve tolerance according to ISO 9906.

Overall performance taking into account FOUR pumps working at the same time.

MODEL	PUMP+INVERTER POWER INPUT	P2 NOMINAL		In A	MCE/P MODEL	MAXIMUM FLOW RATE m³/h	MAX OBTAINABLE PRESSURE BAR	STANDARD PRESSURE BAR
		KW	HP					
4 NKVE 45/2-2 T MCE 400-50	3x400 50-60Hz	2x5,5	2x7,5	2x13,1	MCE55/P	280	3.8	3
4 NKVE 45/2 T MCE 400-50	3x400 50-60Hz	2x7,5	2x10	2x17,6	MCE110/P	280	4.8	4
4 NKVE 45/3 T MCE 400-50	3x400 50-60Hz	2x11	2x15	2x25,5	MCE110/P	280	7.3	6.5
4 NKVE 45/4 T MCE 400-50	3x400 50-60Hz	2x15	2x20	2x34	MCE150/P	280	9.7	8.5

MODEL	A	B	C	H	H1	H2	DNA	DNM	PACKING DIMENSIONS			WEIGHT kg
									L/A	L/B	H	
4 NKVE 45/2-2 T MCE 400-50	2195	1813	1440	1515	306	306	250	200	2660	1760	2200	976
4 NKVE 45/2 T MCE 400-50	2195	1813	1440	1565	306	306	250	200	2660	1760	2200	1020
4 NKVE 45/3 T MCE 400-50	2195	1813	1440	1782	306	306	250	200	2660	1760	2200	1240
4 NKVE 45/4 T MCE 400-50	2195	1813	1440	1864	306	306	250	200	2660	1760	2200	1312