

CyberPower

User's Manual

HSTP3T15KE-C / KEBC-C

HSTP3T20KE-C / KEBC-C

CyberPower Systems, Inc.

www.cyberpower.com

Safety Precautions

This manual contains information concerning the installation and operation of Tower UPS. Please carefully read this manual prior to installation.

The Tower UPS cannot be put into operation until it is commissioned by engineers approved by the manufacturer (or its agent). Not doing so could result in personnel safety risk, equipment malfunction and invalidation of warranty.

Safety Message Definition

Danger: Serious human injury or even death may be caused, if this requirement is ignored.



Warning: Human injury or equipment damage may be caused, if this requirement is ignored.

Attention: Equipment damage, loss of data or poor performance may be caused, if this requirement is ignored.





Commissioning Engineer: The engineer who installs or operates the equipment should be well trained in electricity and safety and familiar with the operation, debug, and maintenance of the equipment.

Warning Label



The warning label indicates the possibility of human injury or equipment damage, and advises the proper step to avoid the danger. In this manual, there are three types of warning labels as below.

Labels	Description
 Danger	Serious human injury or even death may be caused, if this requirement is ignored.
 Warning	Human injury or equipment damage may be caused, if this requirement is ignored.
 Attention	Equipment damage, loss of data or poor performance may be caused, if this requirement is ignored.



Safety Instruction

 Danger	<ul style="list-style-type: none"> ◇ Performed only by commissioning engineers. ◇ This UPS is designed for commercial and industrial applications only, and is not intended for any use in life-support devices or system.
 Warning	<ul style="list-style-type: none"> ◇ Read all the warning labels carefully before operation, and follow the instructions.
	<ul style="list-style-type: none"> ◇ When the system is running, do not touch the surface with this label, to avoid any hurt of scald.
	<ul style="list-style-type: none"> ◇ ESD sensitive components inside the UPS, anti-ESD measure should be taken before handling.

Move & Install

 Danger	<ul style="list-style-type: none"> ✧ Keep the equipment away from heat source or air outlets. ✧ In case of fire, use dry powder extinguisher only, any liquid extinguisher can result in electric shock.
 Warning	<ul style="list-style-type: none"> ✧ Do not start the system if any damage or abnormal parts founded. ✧ Contacting the UPS with wet material or hands may be subject to electric shock.
 Attention	<ul style="list-style-type: none"> ✧ Use proper facilities to handle and install the UPS. Shielding shoes, protective clothes and other protective facilities are necessary to avoid injury. ✧ During positioning, keep the UPS way from shock or vibration. ✧ Install the UPS in proper environment, more detail in section 2.3.

Debug & Operate

 Danger	<ul style="list-style-type: none"> ✧ Make sure the grounding cable is well connected before connecting the power cables, the grounding cable and neutral cable must be in accordance with the local and national codes practice. ✧ Before moving or re-connecting the cables, make sure to cut off all the input power sources, and wait for at least 10 minutes for internal discharge. Use a multi-meter to measure the voltage on terminals and ensure the voltage is lower than 36V before operation.
 Attention	<ul style="list-style-type: none"> ✧ The earth leakage current of load will be carried by RCCB or RCD. ✧ Initial check and inspection should be performed after long time storing of UPS.

Maintenance & Replacement

 Danger	<ul style="list-style-type: none"> ✧ All the equipment maintenance and servicing procedures involving internal access need special tools and should be carried out only by trained personnel. The components that can only be accessed by opening the protective cover with tools cannot be maintained by user. ✧ This UPS full complies with “IEC62040-1-1-General and safety requirements for use in operator access area UPS”. Dangerous voltages are present within the battery box. However, the risk of contact with these high voltages is minimized for non-service personnel. Since the component with dangerous voltage can only be touched by opening the protective cover with a tool, the possibility of touching high voltage component is minimized. No risk exists to any personnel when operating the equipment in the normal manner, following the recommended operating procedures
---	---

	in this manual.
--	-----------------

Battery Safety

 <p>Danger</p>	<ul style="list-style-type: none"> ✧ All the battery maintenance and servicing procedures involving internal access need special tools or keys and should be carried out only by trained personnel. ✧ When connected together, the battery terminal voltage will exceed 400Vdc and is potentially lethal. ✧ Battery manufacturers supply details of the necessary precautions to be observed when working on, or in the vicinity of, a large bank of battery cells. These precautions should be followed implicitly at all times. Particular attention should be paid to the recommendations concerning local environmental conditions and the provision of protective clothing, first aid and fire-fighting facilities. ✧ Ambient temperature is a major factor in determining the battery capacity and life. The nominal operating temperature of battery is 20°C. Operating above this temperature will reduce the battery life. Periodically charge the battery according to the battery user manuals to ensure the back-up time of UPS. ✧ Replace the batteries only with the same type and the same number, or it may cause explosion or poor performance. ✧ When connecting the battery, follow the precautions for high-voltage operation before accepting and using the battery, check the appearance the battery. If the package is damaged, or the battery terminal is dirty, corroded or rusted or the shell is broken, deformed or has leakage, replace it with new product. Otherwise, battery capacity reduction, electric leakage or fire may be caused. <ul style="list-style-type: none"> ● Before operating the battery, remove the finger ring, watch, necklace, bracelet and any other metal jewelry ● Wear rubber gloves. ● Eye protection should be worn to prevent injury from accidental electrical arcs. ● Only use tools (e.g. wrench) with insulated handles. ● The batteries are very heavy. Please handle and lift the battery with proper method to prevent any human injury or damage to the battery terminal. ● Do not decompose, modify or damage the battery. Otherwise, battery short circuit, leakage or even human injury may be caused. ● The battery contains sulfuric acid. In normal operation, all the sulfuric acid is attached to the separation board and plate in the battery. However, when the battery case is broken, the acid will leak from the battery. Therefore, be sure to wear a pair of protective glasses, rubber gloves and skirt when operating the battery. Otherwise, you may become blind if acid enters your
--	---

Safety Precautions

	<p>eyes and your skin may be damaged by the acid.</p> <ul style="list-style-type: none">● At the end of battery life, the battery may have internal short circuit, drain of electrolytic and erosion of positive/negative plates. If this condition continues, the battery may have temperature out of control, swell or leak. Be sure to replace the battery before these phenomena happen.● If a battery leaks electrolyte, or is otherwise physically damaged, it must be replaced, stored in a container resistant to sulfuric acid and disposed of in accordance with local regulations.● If electrolyte comes into contact with the skin, the affected area should be washed immediately with water.
--	--

Disposal

 Warning	◇ Dispose of used battery according to the local instructions
--	---

Contents

Chapter 1 Product Introduction.....	1
1.1 System Configuration	1
1.2 Operation Mode.....	1
1.2.1 Normal Mode	1
1.2.2 Battery Mode	2
1.2.3 Bypass Mode.....	2
1.2.4 Maintenance Mode (Manual Bypass)	2
1.2.5 ECO Mode.....	3
1.2.6 Auto-restart Mode.....	3
1.2.7 Frequency Converter Mode	4
1.3 UPS Structure.....	4
1.3.1 UPS Configuration.....	4
1.3.2 UPS Outlook.....	4
Chapter 2 Installation Instruction.....	6
2.1 Location	6
2.1.1 Installation Environment.....	6
2.1.2 Site Selection.....	6
2.1.3 Size and Weight	6
2.2 Unloading and Unpacking	8
2.2.1 Moving and Unpacking of the Cabinet.....	8
2.3 Positioning.....	10
2.3.1 Positioning Cabinet	10
2.4 Battery	11
2.5 Cable Entry.....	11
2.6 Power Cables	12
2.6.1 Specifications	12
2.6.2 Specifications for Power Cables Terminal.....	12
2.6.3 Circuit Breaker.....	13
2.6.4 Connecting Power Cables.....	13
2.7 Control and Communication Cables	14
2.7.1 Dry Contact Interface	14
2.7.2 Communication Interface	19
2.7.3 Communication Setting.....	19
Chapter 3 LCD Panel.....	21
3.1 Introduction.....	21
3.2 LCD panel for Cabinet.....	21
3.2.1 LED Indicator.....	21
3.2.2 Control and Operation Keys.....	22
3.2.3 LCD Screen	23
3.3 System Information Window	25
3.4 Menu Window.....	25
3.5 Event List.....	26
Chapter 4 Operations	30
4.1 UPS Start-up	30
4.2 Procedure for Switching between Operation Modes	31
4.2.1 Switching the UPS into Battery Mode from Normal Mode.....	31
4.2.2 Switching the UPS into Bypass Mode from Normal Mode	31
4.2.3 Switching the UPS into Normal Mode from Bypass Mode	31

4.2.4 Switching the UPS into Maintenance Bypass Mode from Normal Mode.....	31
4.2.5 Switching the UPS into Normal Mode from Maintenance Bypass Mode.....	32
4.3 Battery Maintenance	32
4.4 EPO	33
4.5 Installation of Parallel Operation System	34
4.5.1 Parallel system diagram	34
4.5.2 Parallel system setting	36
Chapter 5 Maintenance	39
5.1 Precautions.....	39
5.2 Instruction for Maintaining UPS.....	39
5.3 Instruction for Maintaining Battery string.....	39
5.3.1 Installation of internal battery	40
Chapter 6 Product Specification	42
6.1 Applicable Standards	42
6.2 Environmental Characteristics	42
6.3 Mechanical Characteristic	42
6.4 Electrical Characteristics	43
6.4.1 Electrical Characteristics (Input Rectifier)	43
6.4.2 Electrical Characteristics (Intermediate DC Link)	43
6.4.3 Electrical Characteristics (Inverter Output)	44
6.4.4 Electrical Characteristics (Bypass Mains Input).....	44
6.5 Efficiency	45
6.6 Display and Interface.....	45

Chapter 1 Product Introduction

1.1 System Configuration

The Tower UPS is configured by the following part: Rectifier, Charger, Inverter, Static Switch and Manual Bypass Switch. One or several battery strings should be installed to provide backup energy once the utility fails. The UPS structure is shown in Fig. 1-1.

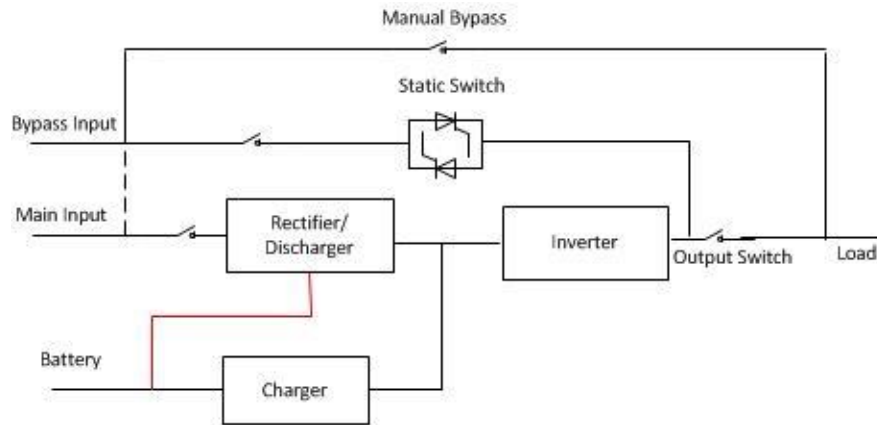

Fig.1-1 UPS Configuration

1.2 Operation Mode

The Tower UPS is an on-line, double-conversion UPS that permits operation in the following modes:

- Normal mode
- Battery mode
- Bypass mode
- Maintenance mode (manual bypass)
- ECO mode
- Auto-restart mode
- Frequency Converter mode

1.2.1 Normal Mode

The inverter of power modules continuously supply the critical AC load. The rectifier/charger derives power from the AC mains input source and supplies DC power to the inverter while simultaneously FLOAT or BOOST charging its associated backup battery.

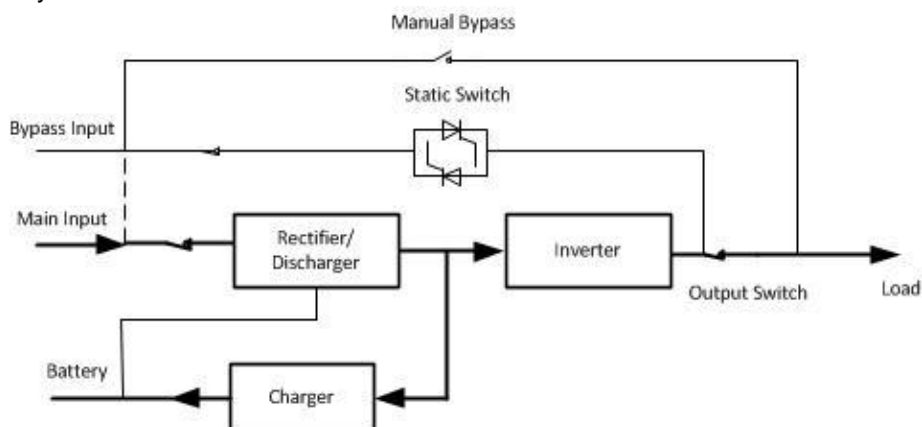

Fig.1-2 Normal mode operation diagram

1.2.2 Battery Mode

Upon failure of the AC mains input power, the inverter of power modules, which obtain power from the battery, supply the critical AC load. There is no interruption in power to the critical load upon failure. After restoration of the AC mains input power, the "Normal mode" operation will continue automatically without the necessity of user intervention.

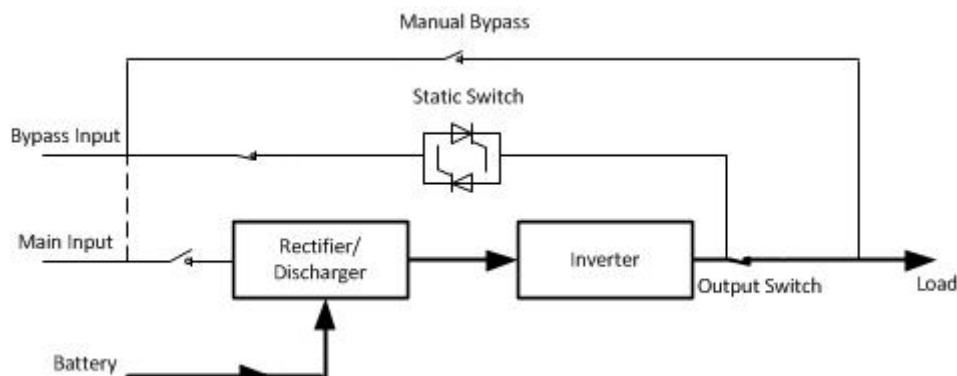

Fig.1-3 Battery mode operation diagram

1.2.3 Bypass Mode

If the inverter overload capacity is exceeded under Normal mode, or if the inverter becomes unavailable for any reason, the static transfer switch will perform a transfer of the load from the inverter to the bypass source, with no interruption in power to the critical AC load. Should the inverter be asynchronous with the bypass, the static switch will perform a transfer of the load from the inverter to the bypass with power interruption to the load. This is to avoid large cross currents due to the paralleling of unsynchronized AC sources. This interruption is programmable but typically set to be less than 3/4 of an electrical cycle, e.g., less than 15ms (50Hz) or less than 12.5ms (60Hz). The action of transfer/re-transfer can also be done by the command through monitor.

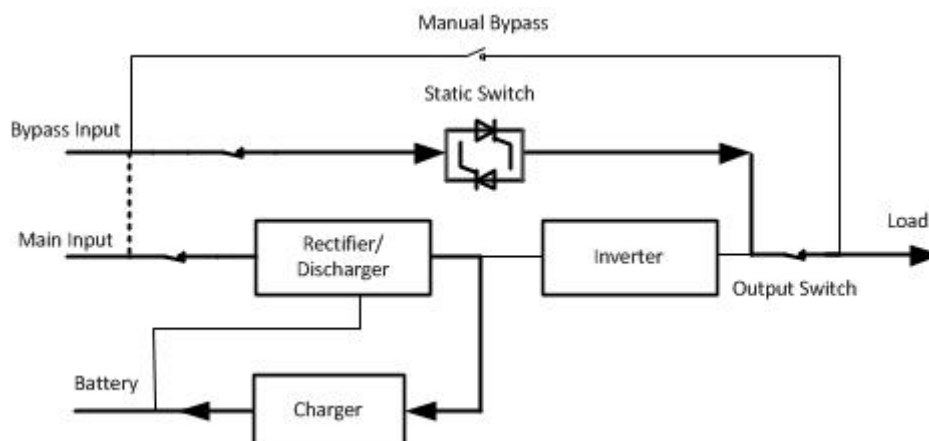

Fig.1-4 Bypass mode operation diagram

1.2.4 Maintenance Mode (Manual Bypass)

A manual bypass switch is available to ensure continuity of supply to the critical load when the UPS becomes unavailable e.g. during a maintenance procedure. (See Fig.1-5).

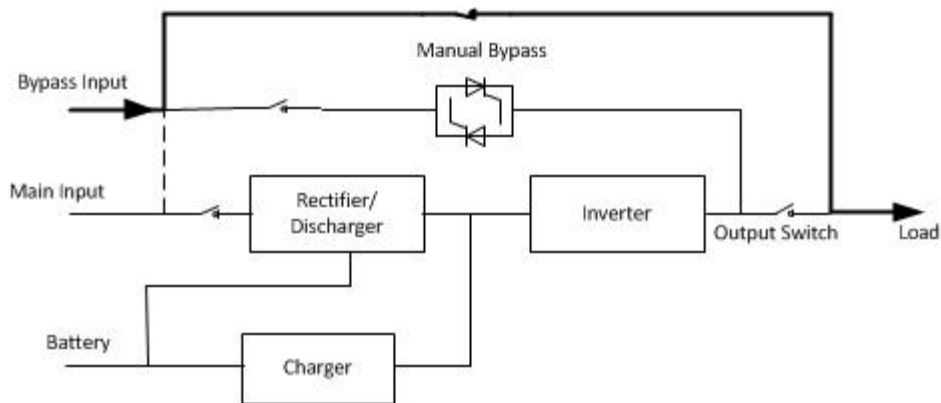

Fig.1-5 Maintenance mode operation diagram

**Danger**

During Maintenance mode, dangerous voltages are present on the terminal of input, output and neutral, even with all the modules and the LCD turned off.

1.2.5 ECO Mode

To improve system efficiency, UPS rack system works in Bypass mode at normal time, and inverter is standby. When the utility fails, the UPS transfers to Battery Mode and the inverter provide powers to the loads.

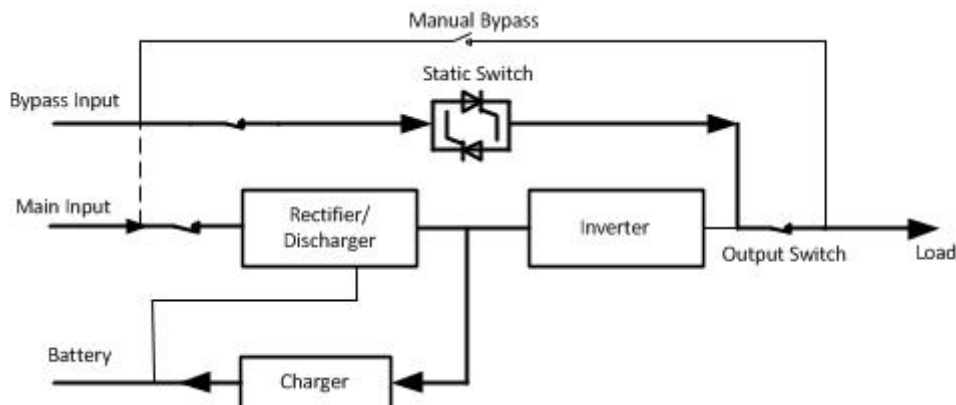

Fig.1-6 ECO Mode operation diagram

**Note**

There is a short interruption time (less than 10ms) when transfer from ECO mode to battery mode, it must be sure that the interruption has no effect on loads.

1.2.6 Auto-restart Mode

The battery may become exhausted following an extended AC mains failure. The inverter shuts down when the battery reaches the End of Discharge Voltage (EOD). The UPS may be programmed to "System Auto Start Mode after EOD". The system starts after a delay time when the AC main recovers. The mode and the delay time are programmed by the commissioning engineer.

1.2.7 Frequency Converter Mode

By setting the UPS to Frequency Converter mode, the UPS could present a stable output of fixed frequency (50 or 60Hz), and the bypass static switch is not available.

1.3 UPS Structure

1.3.1 UPS Configuration

The UPS configuration is provided in Table 1.1

Table1.1 UPS Configuration

Item	Components	Quantity	Remark
Standard Backup Type	Circuit Breakers	5	Standard
	Dual Input	1	Standard
	Parallel Card,	1	Optional
	SNMP Card	1	Optional
Long Backup Type	Circuit Breakers	4	Standard
	Dual Input	1	Standard
	Parallel Card,	1	Optional
	SNMP Card	1	Optional

1.3.2 UPS Outlook

The UPS outlook is shown as Fig.1-7 to Fig.1-9.

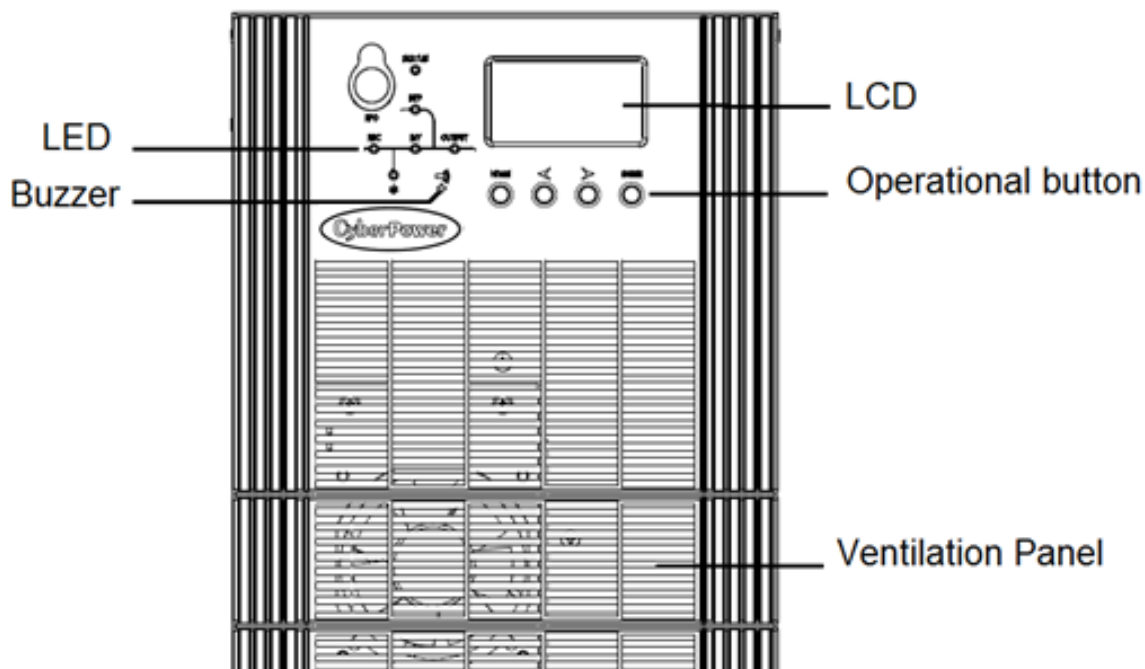

Fig.1-7 Front appearance

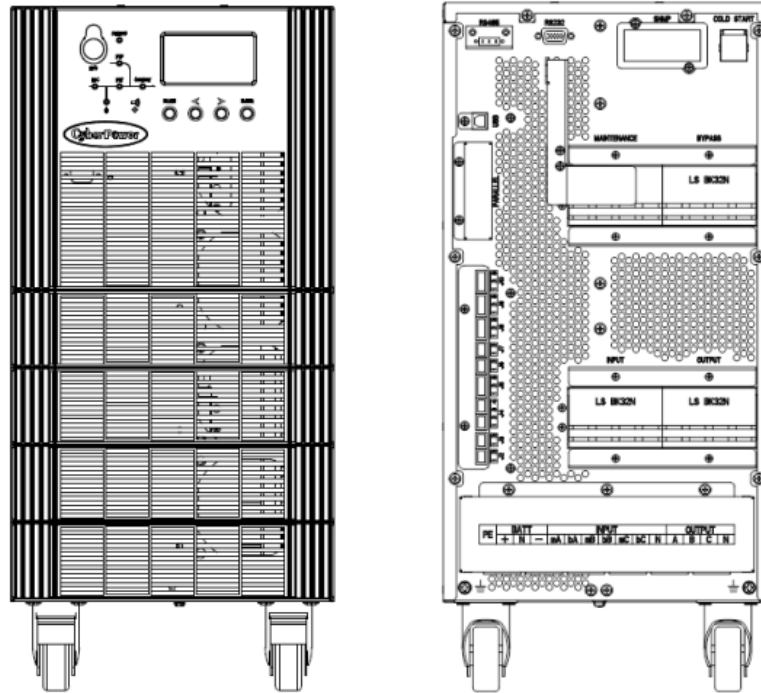

Fig.1-8 System outlook

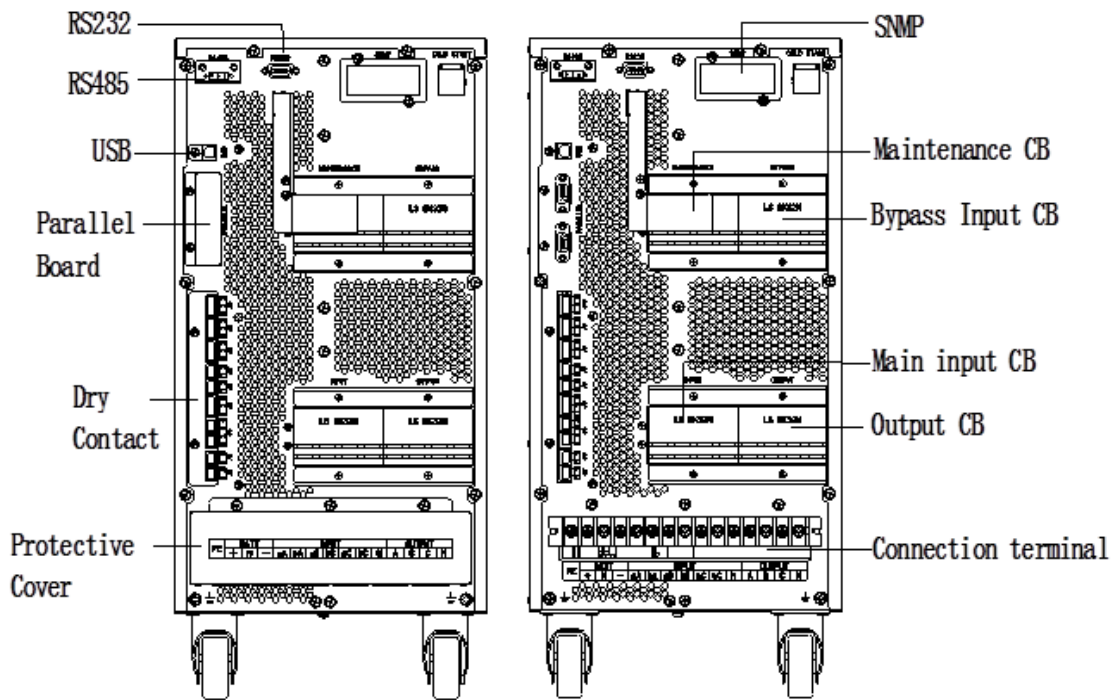

Fig.1-9 15/20 kVA back appearance

Chapter 2 Installation Instruction

2.1 Location

As each site has its requirements, the installation instructions in this section are to act as a guide for the general procedures and practices that should be observed by the installing engineer.

2.1.1 Installation Environment

The UPS is intended for indoor installation and uses forced convection cooling by internal fans. Please make sure there is enough space for the UPS ventilation and cooling.

Keep the UPS far away from water, heat and inflammable and explosive, corrosive material. Avoid installing the UPS in the environment with direct sunlight, dust, volatile gases, corrosive material and high salinity.

Avoid installing the UPS in the environment with conductive dirt.

The operating environment temperature for battery is 20°C -25°C. Operating above 25°C will reduce the battery life, and operation below 20°C will reduce the battery capacity.

The battery will generate a little amount of hydrogen and oxygen at the end of charging; ensure the fresh air volume of the battery installation environment must meet EN50272-2001 requirements.

If external batteries are to be used, the battery circuit breakers (or fuses) must be mounted as close as possible to the batteries, and the connecting cables should be as short as possible.

2.1.2 Site Selection

Ensure the ground or installation platform can bear the weight of the UPS cabinet ,batteries and battery rack.

No vibration and less than 5 degree inclination horizontally.

The equipment should be stored in a room so as to protect it against excessive humidity and heat sources.

The battery needs to be stored in dry and cool place with good ventilation. The most suitable storage temperature is 20°C to 25°C.

2.1.3 Size and Weight

The size of three dimensions for the UPS cabinet is shown in Fig. 2-1.



Attention

Ensure there is at least 0.8m before the front of the cabinet so as to easily maintain and at least 0.5m behind for ventilation and cooling. The room reserved for the cabinet is shown in Fig. 2-2.

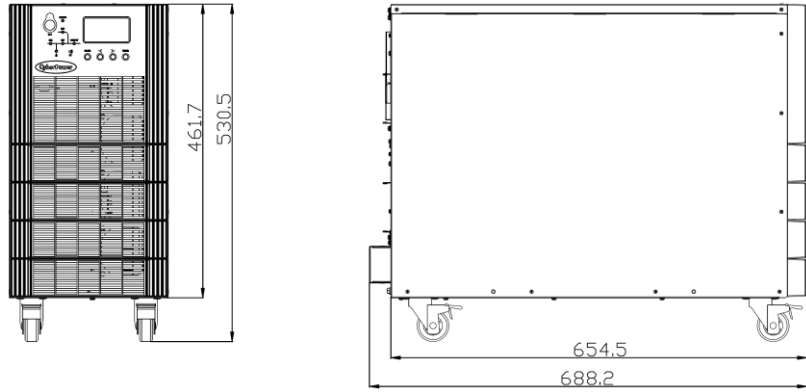

Fig.2-1-1 Size of the Long Backup Type (Unit : mm)

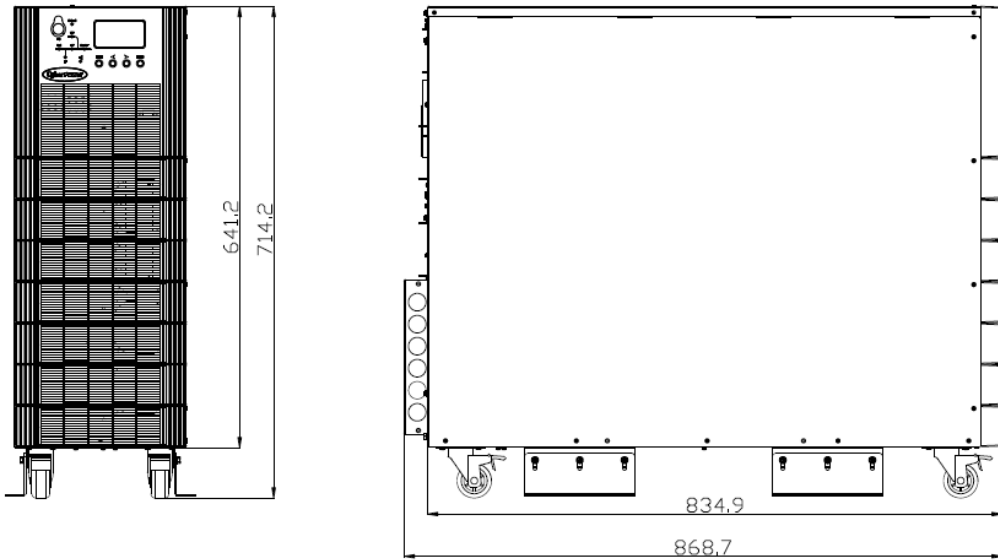

Fig.2-1-2 Size of the standard backup Type (Unit : mm)

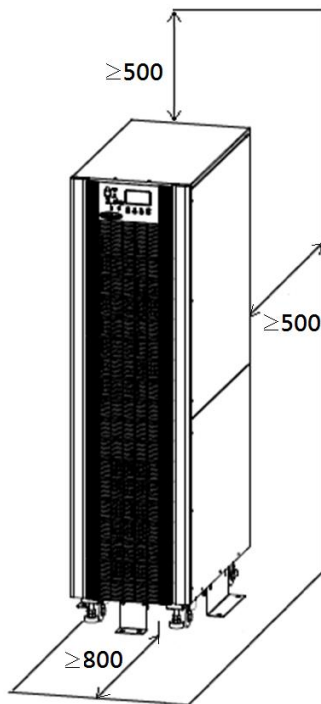

Fig.2-2 Room reserved for the cabinet(Unit : mm)

The weight for the UPS cabinet is shown in Table 2.1

Table 2.1 Weight for the cabinet

Configuration	Weight
15kVA/20kVA Standard Backup Type	52kg(No Batteries Included)
15kVA/20kVA Long Backup Type	31kg

2.2 Unloading and Unpacking

2.2.1 Moving and Unpacking of the Cabinet

The steps to move and unpack the cabinet are as follows :

1. Check if any damages to the packing. (If any, contact to the carrier)
2. Transport the equipment to the designated site by forklift, as shown in Fig.2-3.

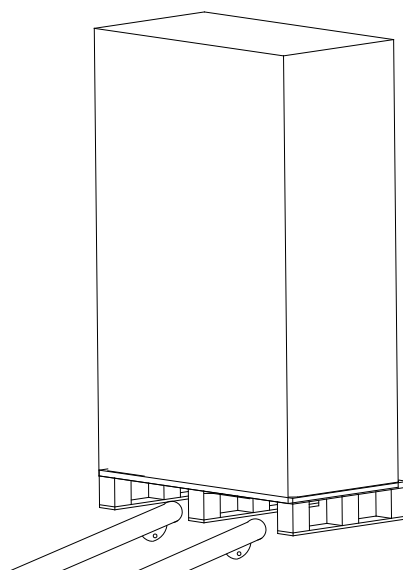

Fig.2-3 Transport to the designated site

3. Unpack the package (see Fig.2-4).

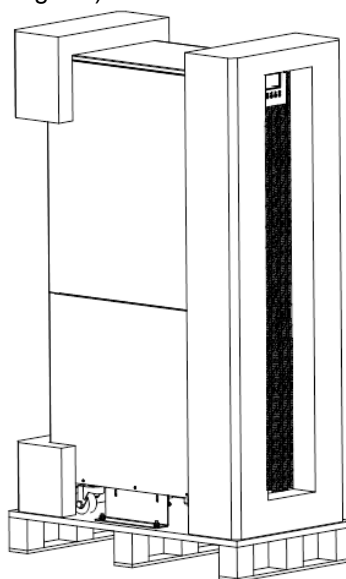

Fig.2-4 Disassemble the case

4. Remove the protective foam around the cabinet.

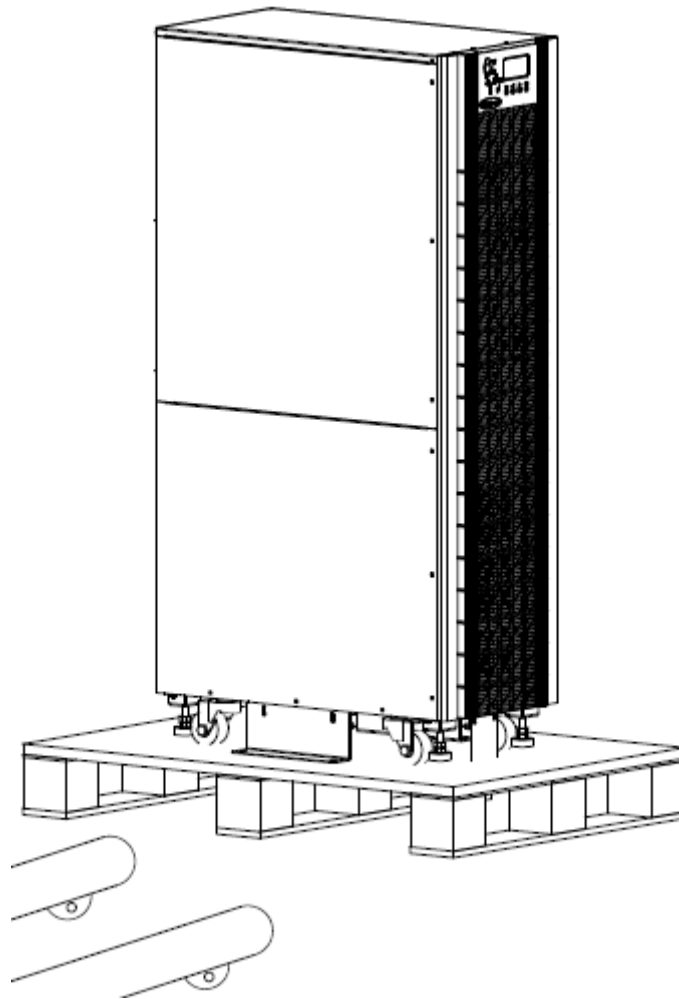

Fig.2-5 Remove the protective foam

5. Check the UPS.
 - (a) Visually examine if there are any damages to UPS during transportation. If any, contact to the carrier.
 - (b) Check the UPS with the list of the goods. If any items are not included in the list, contact to our company or the local office.
6. Dismantle the bolt that connects the cabinet and wooden pallet after disassembly.
7. Move the cabinet to the installation position.



Attention

Be careful while removing to avoid scratching the equipment.



Attention

The waste materials of unpacking should be disposed to meet the demand for environmental protection.

2.3 Positioning

2.3.1 Positioning Cabinet

The UPS cabinet has two way of supporting itself: One is to support itself temporarily by the four wheels at the bottom, making it convenient to adjust the position of the cabinet ; The other is by anchor bolts to support the cabinet permanently after adjusting the position of the cabinet. The supporting structure is shown in Fig. 2-6.

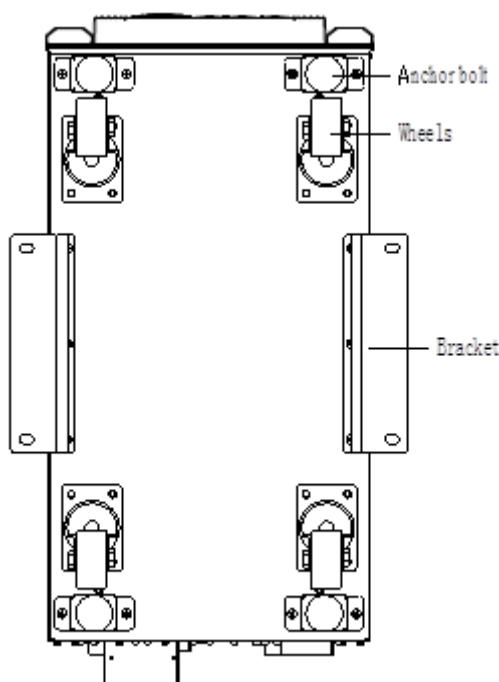

Fig.2-6 Supporting structure (Bottom view)

The steps to position the cabinet are as follows :

1. Ensure the supporting structure is in good condition and the mounting floor is smooth and strong.
2. Retract the anchor bolts by turning them counterclockwise using wrench, the cabinet is then supported by the four wheels.
3. Adjust the cabinet to the right position by the supporting wheels.
4. Put down the anchor bolts by turning them clockwise using wrench, the cabinet is then supported by the four anchor bolts.
5. Ensure the four anchor bolts are in the same height and the cabinet is fixed and immovable.
6. Positioning done.



Attention

Auxiliary equipment is needed when the mounting floor is not solid enough to support the cabinet, which helps distribute the weight over a larger area. For instance, cover the floor with iron plate or increase the supporting area of the anchor bolts.

2.4 Battery

Three terminals (positive, neutral, negative) are drawn from the battery unit and connected to UPS system. The neutral line is drawn from the middle of the batteries in series (See Fig.2-7).

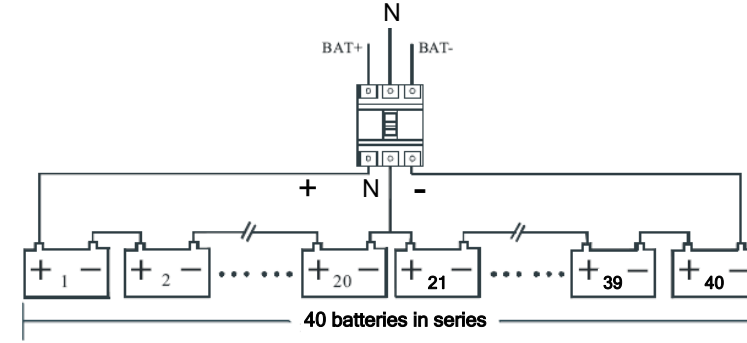

Fig.2-7 Battery string wiring diagram



Danger

The battery terminal voltage is of more than 200Vdc, please follow the safety instructions to avoid electric shock hazard.

Ensure the positive, negative, neutral electrode is correctly connected from the battery unit terminals to the breaker and from the breaker to the UPS system.

2.5 Cable Entry

Cables can enter the UPS cabinet from the side or from the bottom. Cable entry is made possible through a blanking plate fitted at the bottom of the equipment. The cable entry is shown in Fig.2-8.

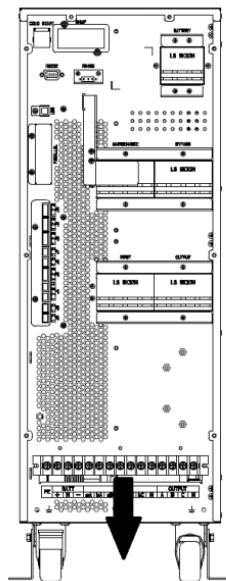

Fig.2-8 Cable entry

2.6 Power Cables

2.6.1 Specifications

The UPS power cables are recommended in Table 2.2.

Table 2.2 Recommended cables for power cables

Contents		15/20kVA	
Main Input	Main Input Current(A)		18/28A
	Cable Section (mm ²)	A	6
		B	6
		C	6
Main Output	Main Output Current(A)		15/23A
	Cable Section (mm ²)	A	6
		B	6
		C	6
Bypass Input (Optional)	Bypass Input Current(A)		15/23A
	Cable Section (mm ²)	A	6
		B	6
		C	6
Battery Input	Battery Input current(A)		20/30A
	Cable Section (mm ²)	+	8
		-	8
PE	Cable Section (mm ²)	N	8
		PE	6



Note

The recommended cable section for power cables are only for situations described below :

- Ambient temperature : 30°C .
- AC loss less than 3% , DC loss less than 1% , The length of the AC power cables are no longer than 50 m and the length of the DC power cables are no longer than 30 m .
- Currents listed in the table are based on the 208V system (Line-to-line voltage).
- The size of neutral lines should be 1.5~1.7 times the value listed above when the predominant load is non-linear.

2.6.2 Specifications for Power Cables Terminal

Specifications for power cables connector are listed as Table 2.3.

Table 2.3 Requirements for terminal

Port	Connection	Bolt	Bolt Aperture	Torque Moment
Mains input	Cables crimped OT terminal	M6	7mm	4.9Nm
Bypass Input	Cables crimped OT terminal	M6	7mm	4.9Nm
Battery Input	Cables crimped OT terminal	M6	7mm	4.9Nm

Output	Cables crimped OT terminal	M6	7mm	4.9Nm
PE	Cables crimped OT terminal	M6	7mm	4.9Nm

2.6.3 Circuit Breaker

The circuit breakers (CB) for the system are recommended in Table 2.4.

Table 2.4 Recommended CB

Installed position	15/20kVA
Battery CB	32A,250Vdc



Attention

The CB with RCD (Residual Current Device) is not suggested for the system.

2.6.4 Connecting Power Cables

The steps of connecting power cables are as follows:

1. Verify that all the switches of the UPS are completely open and the UPS internal maintenance bypass switch is open. Attach necessary warning signs to these switches to prevent unauthorized operation.
2. Open the back door of the cabinet, remove the plastic cover. The input and output terminal, battery terminal and protective earth terminal are shown in Fig.2-9.

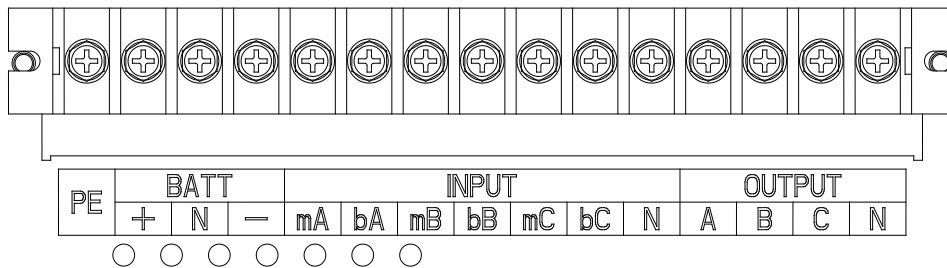

Fig.2-9 connections terminals

3. Connect the protective earth wire to protective earth terminal (PE).
4. Connect the AC input supply cables to the Input terminal and AC output supply cables to the Output terminal.
5. Connect the Battery cables to the Battery terminal.
6. Check to make sure there is no mistake and re-install all the protective covers.

Note: mA, mB, mC standard for Main input phase A,B and C; bA, bB, bC standard for Bypass Input phase A,B and C.



Attention

The operations described in this section must be performed by authorized electricians or qualified technical personnel. If you have any difficulties, contact the manufacturer or agency.

 **Warning**

- Tighten the connections terminals to enough torque moment, refer to Table 2.3, and please ensure correct phase rotation.
- The grounding cable and neutral cable must be connected in accordance with local and national codes.
- When the cable holes does not goes through by cables, it should be filled by the hole stopper

2.7 Control and Communication Cables

The front panel of the bypass module provides dry contact interface (J2-J11) and communication interface (RS232, RS485,SNMP ,Intelligent card interface and USB port), as it is shown in Fig.2-10.

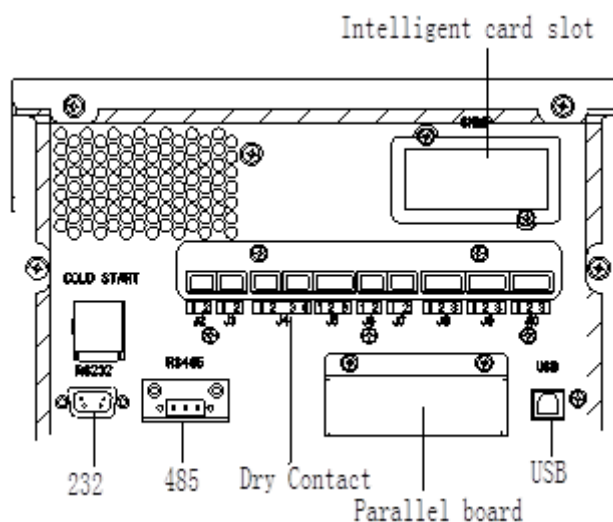

Fig.2-10 Dry contact & communication interface

2.7.1 Dry Contact Interface

Dry contact interface includes port J2-J11 and the functions of the dry contact are shown in Table 2.5.

Table 2.5 Functions of the port

Port	Name	Function
J2-1	TEMP_BAT	Detection of battery temperature
J2-2	TEMP_COM	Common terminal for temperature detection
J3-1	ENV_TEMP	Detection of environmental temperature
J3-2	TEMP_COM	Common terminal for temperature detection
J4-1	REMOTE_EPO_NC	Trigger EPO when disconnect with J4-2
J4-2	+24V_DRY	+24V
J4-3	+24V_DRY	+24V
J4-4	REMOTE_EPO_NO	Trigger EPO when shorted with J4-3
J5-1	+24V_DRY	+24V
J5-2	GEN_CONNECTED	Input dry contact , function is settable , Default: interface for generator

J5-3	GND_DRY	Ground for +24V
J6-1	BCB Drive	Output dry contact, function is settable. Default: Battery trip signal
J6-2	BCB_Status	Input dry contact, function is settable. Default: BCB Status and BCB Online, (Alert no battery when BCB Status is invalid).
J7-1	GND_DRY	Ground for +24V
J7-2	BCB_Online	Input dry contact, function is settable. Default: BCB Status and BCB Online (Alert no battery when BCB Status is invalid).
J8-1	BAT_LOW_ALARM_NC	Output dry contact (Normally closed), function is settable. Default: Low battery alarming
J8-2	BAT_LOW_ALARM_NO	Output dry contact (Normally open), function is settable. Default: Low battery alarming
J8-3	BAT_LOW_ALARM_GND	Common terminal for J8-1 and J8-2
J9-1	GENERAL_ALARM_NC	Output dry contact, (Normally closed) function is settable. Default: Fault alarming
J9-2	GENERAL_ALARM_NO	Output dry contact, (Normally open) function is settable. Default: Fault alarming
J9-3	GENERAL_ALARM_GND	Common terminal for J9-1 and J9-2
J10-1	UTILITY_FAIL_NC	Output dry contact, (Normally closed) function is settable. Default: Utility abnormal alarming
J10-2	UTILITY_FAIL_NO	Output dry contact, (Normally open) function is settable. Default: Utility abnormal alarming
J10-3	UTILITY_FAIL_GND	Common terminal for J10-1 and J10-2



Note

The settable functions for each port can be set by the monitor software.
The default functions of each port are described as follows.

Battery Warning Output Dry Contact Interface

The input dry contact J2 and J3 can detect the temperature of batteries and environment respectively, which can be used in environment monitoring and battery temperature compensation.

Interfaces diagram for J2 and J3 are shown in Fig.2-11, the description of interface is in Table 2.6.

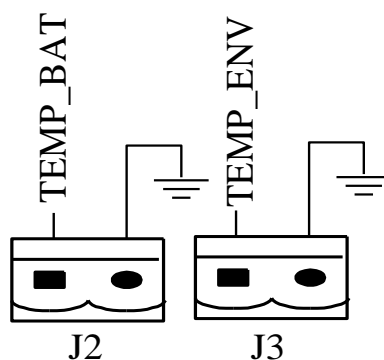

Fig.2-11 J2 and J3 for temperature detecting

Table 2.6 Description of J2 and J3

Port	Name	Function
J2-1	TEMP_BAT	Detection of battery temperature
J2-2	TEMP_COM	Common terminal
J3-1	ENV_TEMP	Detection of environmental temperature
J3-2	TEMP_COM	Common terminal



Note

Specified temperature sensor is required for temperature detection (R25=5Kohm, B25/50=3275), please confirm with the manufacturer, or contact the local maintenance engineers when placing an order.

Remote EPO Input Port

J4 is the input port for remote EPO. It requires shorting NC and +24V and disconnecting NO and +24V during normal operation, and the EPO is triggered when opening NC and +24V or shorting the NO and +24V. The port diagram is shown in Fig.2-12, and port description is shown in Table 2.7.

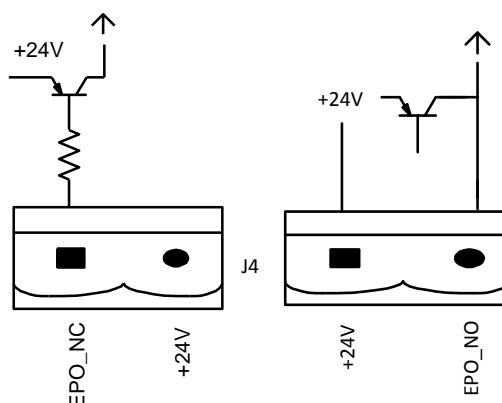

Fig.2-12 Diagram of input port for remote EPO

Table 2.7 Description of input port for remote EPO

Port	Name	Function
J4-1	REMOTE_EPO_NC	Trigger EPO when disconnect with J4-2
J4-2	+24V_DRY	+24V
J4-3	+24V_DRY	+24V
J4-4	REMOTE_EPO_NO	Trigger EPO when connect with J4-3

Generator Input Dry Contact

The default function of J5 is the interface for generator J5 Connect pin 2 of J5 with +24V power supply; it indicates that the generator has been connected with the system. The interface diagram is shown in Fig.2-13, and interface description is shown in Table 2.8.

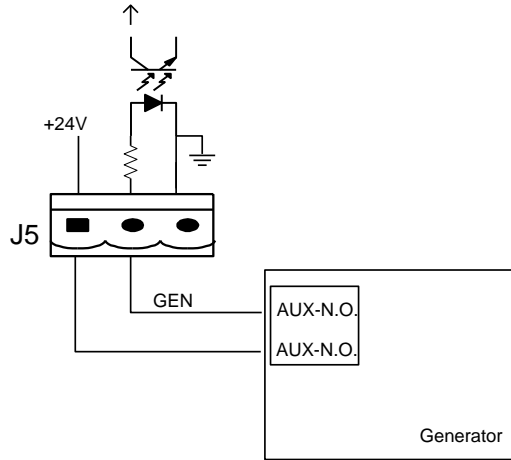

Fig.2-13 Diagram of status interface and connection of generator

Table 2.8 Description of status interface and connection of generator

Port	Name	Function
J5-1	+24V_DRY	+24V
J5-2	GEN_CONNECTED	Connection status of generator
J5-3	GND_DRY	Power ground for +24V

BCB Input Port

The default function of J6 and J7 are the ports of BCB. The port diagram is shown in Fig.2-14, and description is shown in Table 2.9.

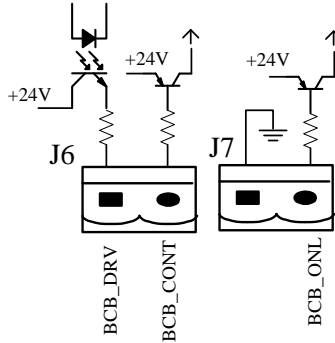

Fig.2-14 BCB Port

Table 2.9 Description of BCB port

Port	Name	Function
J6-1	BCB_DRIV	BCB contact drive, provides +24V voltage, 20mA drive signal
J6-2	BCB_Status	BCB contact status, connect with the normally open signal of BCB
J7-1	GND_DRY	Power ground for +24V
J7-2	BCB_Online	BCB on-line input (normally open) , BCB is on-line when the signal is connecting with J7-1

Battery Warning Output Dry Contact Interface

The default function of J8 is the output dry contact interface, which presents the battery warnings of low or excessive voltage, when the battery voltage is lower than set value, an auxiliary dry contact signal will be activated via the isolation of a relay. The interface diagram is shown in Fig.2-15, and description is shown in Table 2.10.

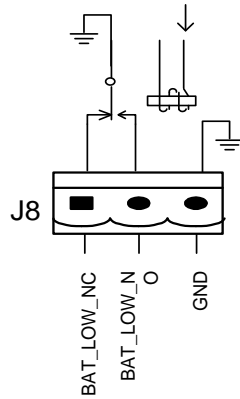

Fig.2-15 Battery warning dry contact interface diagram

Table2.10 Battery warning dry contact interface description

Port	Name	Function
J8-1	BAT_LOW_ALARM_NC	Battery warning relay (normally closed) will be open during warning
J8-2	BAT_LOW_ALARM_NO	Battery warning relay (normally open) will be closed during warning
J8-3	BAT_LOW_ALARM_GND	Common terminal

General Alarm Output Dry Contact Interface

The default function of J9 is the general alarm output dry contact interface. When one or more warnings are triggered, an auxiliary dry contact signal will be active via the isolation of a relay. The interface diagram is shown in Fig.2-16, and description is shown in Table 2.11.

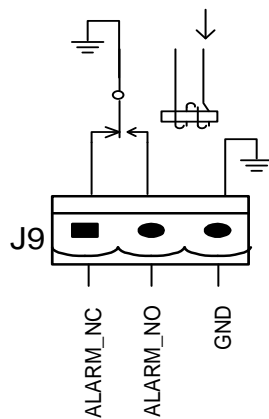

Fig.2-16 Integrated warning dry contact interface diagram

Table2.11 General alarm dry contact interface description

Port	Name	Function
J9-1	GENERAL_ALARM_NC	Integrated warning relay (normally closed) will be open during warning

Port	Name	Function
J9-2	GENERAL_ALARM_NO	Integrated warning relay (normally open) will be closed during warning
J9-3	GENERAL_ALARM_GND	Common terminal

Utility Fail Warning Output Dry Contact Interface

The default function of J10 is the output dry contact interface for utility failure warning, when the utility fails, the system will send a utility failure warning information, and provide an auxiliary dry contact signal via the isolation of a relay. The interface diagram is shown in Fig.2-17, and description is shown in Table 2.12.

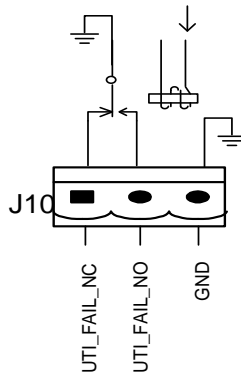

Fig.2-17 Utility failure warning dry contact interface diagram

Table 2.12 Utility failure warning dry contact interface description

Port	Name	Function
J10-1	UTILITY_FAIL_NC	Mains failure warning relay(normally closed) will be open during warning
J10-2	UTILITY_FAIL_NO	Mains failure warning relay (normally open) will be closed during warning
J10-3	UTILITY_FAIL_GND	Common terminal

2.7.2 Communication Interface

RS232、RS485 and USB port: Provide serial data which can be used for commissioning and maintenance by authorized engineers or can be used for networking or integrated monitoring system in the service room.

SNMP: Used on site installation for communication (Optional).

Intelligent card interface: Extension dry contact interface (Optional).

2.7.3 Communication Setting



Please select the icon from main menu to setting protocol of communication.

■ SNMP card(optional)

Table 2.13 SNMP card setting

Model	COMM Set	Remark
RMCARD205	Modbus Mode : ASCII Baud rate : 9600	Firmware version of RMCARD205 should be FW1.09 or newest

■ Communication Port

Table 2.14 Pin assignment for communication port

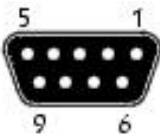
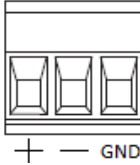
RS_232			RS_485	
				
COMM Set : Modbus			COMM Set : SNT	
Pin	Signal	Description	Pin	Signal
1	DCD	Data Carrier Detect	1	485_+
2	TXD	Transmit Data	2	485_-
3	RXD	Receive Data	3	GND
4	DTR	Data Terminal Ready	4	
5	GND	Ground	5	
6	DSR	Data set Ready	6	
7	RTS	Request to Send	7	
8	CTS	Clear to Send	8	
9	RI	Ring indicator	9	

Chapter 3 LCD Panel

3.1 Introduction

This chapter introduces the functions and operator instructions of the operator control and display panel in detail, and provides LCD display information, including LCD display types, detailed menu information, prompt window information and UPS alarm information.

3.2 LCD panel for Cabinet

The structure of operator control and display panel for cabinet is shown in Fig.3-1.

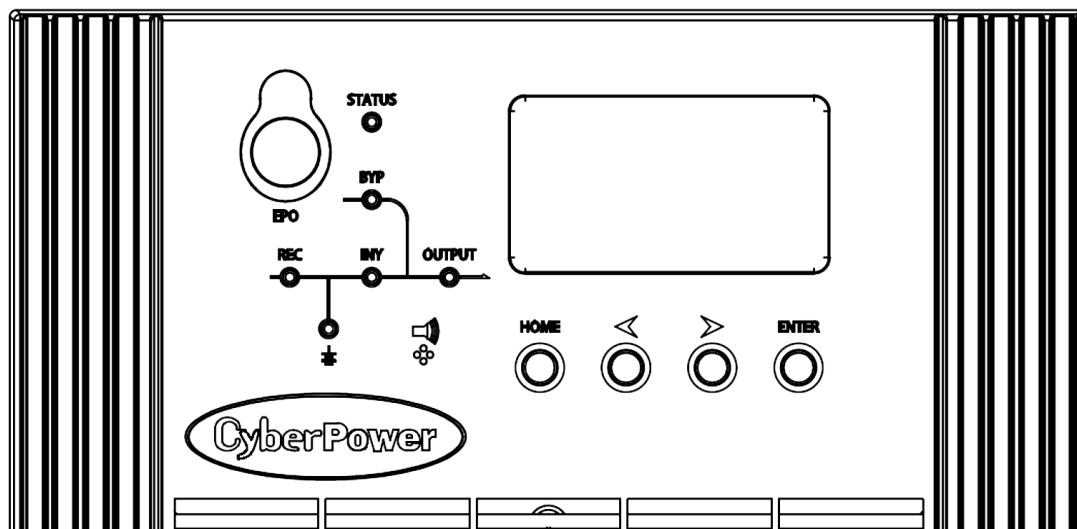

Fig.3-1 Control and display panel for cabinet

The LCD panel for cabinet is divided into three functional areas : LED indicator, control and operation keys and LCD screen.

3.2.1 LED Indicator

There are 6 LEDs on the panel to indicate the operating status and fault. (See Fig.3-1).The description of indicators is shown in Table 3.1

Table 3.1 Status description of indicators

Indicators	State	Description
Rectifier indicator	Steady green	Rectifier normal
	Flashing green	Rectifier normal for at least one module, mains normal
	Steady red	Rectifier fault
	Flashing red	Mains abnormal for at least one module
	Off	Rectifier not operating
Battery indicator	Steady green	Battery charging
	Flashing green	Battery discharging
	Steady red	Battery abnormal (battery failure, no battery or battery reversed) or battery converter abnormal (failure, over current or over temperature) , EOD
	Flashing red	Battery low voltage

Indicators	State	Description
	Off	Battery and battery converter normal, battery not charging
Bypass indicator	Steady green	Load supplied by bypass
	Steady red	Bypass abnormal or out of normal range, or static bypass switch fault
	Flashing red	Bypass voltage abnormal
	Off	Bypass normal
Inverter indicator	Steady green	Load supplied by inverter
	Flashing green	Inverter on, start, synchronization or standby (ECO mode) for at least one module
	Steady red	System output not supplied by inverter, inverter fault for at least one module.
	Flashing red	System output supplied by inverter, inverter fault for at least one module.
	Off	Inverter not operating
Load indicator	Steady green	UPS output ON and normal
	Steady red	UPS overload time is out, or output short, or output no power supply
	Flashing red	Overload output of UPS
	Off	No output of UPS
Status indicator	Steady green	Normal operation
	Steady red	Failure

There are two different types of audible alarm during UPS operation, as shown in Table 3.2.



Table 3.2 Description of audible alarm

Alarm	Description
Two short alarm with a long one	When system has general alarm (for example: AC fault),
Continuous alarm	When system has serious faults (for example: fuse or hardware fault)

3.2.2 Control and Operation Keys

Control and operation keys include four keys. The functions description is shown in Table 3.3.

Table 3.3 Functions of Control and operation keys

Function Key	Description
EPO	Long press, cut off the load power (shut down the rectifier, inverter, static bypass and battery)
HOME	Back to home page
	Page up
	Page down
ENTER	Confirm



Attention

When bypass frequency is over track, there is interruption time (less than 10ms) for transferring from bypass to inverter.

3.2.3 LCD Screen

After the monitoring system starts self-test, the system enters the home page, following the welcome window. The home page is shown in Fig.3-2.

Home page consists of System Information Window, Menu Window and Current Command and Record Menu.

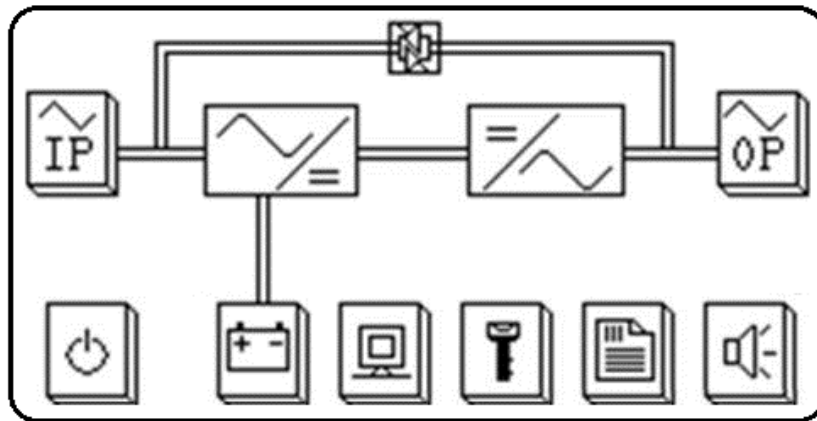











Fig.3-2 Home page

The description of LCD icons is shown in Table 3.4.

Table 3.4 Description of LCD Icons

Icon	Description
	Power On/Off button
	Parameters of Main & Bypass Input
	History log
	Function set(Fault Clear, Battery Test, Battery Maintenance, language set, Manual Transfer, etc.), System Configuration(For Service Engineer Only)
	Parameters of Battery, DC bus information, Temperature etc.
	Parameters of Output & Load
	Warning, S-code and System Information(Rated parameters, Version Information)
	Mute Button

Select the icon, system enters the corresponding page; take the icon  (Main Input) for example, as shown in Fig.3-3.



HOME 	I/P MAIN	 NEXT
A	B	C
220.1 V	220.1 V	220.1 V
45.0 A	45.0 A	45.0 A
50.01 Hz	50.01 Hz	50.01 Hz
0.99 PF	0.99 PF	0.99 PF

Fig.3-3 Main input page

Select the icon of , it will display the information of battery, as shown in Fig.3-4.





HOME 	BATTERY P.1	 NEXT
Batt Volt	240.0 V	240.0 V
Batt Curr	5.0 A	5.0 A
Batt Number	40	
Dischag Times	10	
Status	Batt Boost	

Fig 3-4 Battery Information

Select , to view the current status of the UPS ;

Select , to turn off the buzzer raising from general alarms;

Select , to view the system information and maintenance code;

 **Note**

The LCD will go to sleep in 2 minutes during which time if there are no warnings or faults. Press any button to wake the screen up.

3.3 System Information Window

System Information Window displays the current time and UPS model, as is shown in the following Table 3.5.

Table 3.5 Description of System Information Window

Content	Description
HSTP3T20KE	UPS mode:3-phase in 3-phase out 20kVA,standard backup type
16:30	Current time

3.4 Menu Window

The Menu Window displays the menu name of data window, while the data window displays the related contents of selected menu in menu window. Select UPS menu and data window to browse related parameters of UPS and set related functions. The details are given in Table 3.6.

Table.3.6 Description of UPS Menu

Menu name	Menu item	Meaning
Main input	V phase(V)	Voltage
	I phase(A)	Current
	Freq.(Hz)	Frequency
	PF	Power factor
Bypass input	V phase(V)	Voltage
	Freq. (Hz)	Frequency
	I phase(A)	Current
	PF	Power factor
Output	V phase(V)	Voltage
	I phase(A)	Current
	Freq. (Hz)	Frequency
	PF	Power factor
Load of UPS	Sout (kVA)	Apparent Power
	Pout (kW)	Active Power
	Qout (kVAR)	Reactive Power
	Load (%)	Load percent
Battery data	Environmental Temp	Environmental Temp
	Battery voltage(V)	Positive and negative battery voltage
	Battery current A)	Positive and negative battery current
	Battery Temp(°C)	Battery Temperature
	Remaining Time (Min.)	Remained battery backup time
	Battery capacity (%)	Remained battery capacity
	battery boost charging	Battery is working in boost charging mode
	battery float charging	Battery is working in float charging mode
Battery disconnected	Battery is not connected	
Current		Display all current alarm. The alarms are displayed

Menu name	Menu item	Meaning
alarm		on LCD
History log		Display all history logs.
Function Settings	Display calibration	Adjust the accuracy of LCD display
	Date format set	MONTH-DATE-YEAR and YEAR-MONTH-DATE formats can be selected
	Date & Time	Date/Time set
	Language set	User can set the language
	Communication set	/
	Control password 1 set	User can modify control password 1
Command	Battery maintenance test	This test will lead to the battery being partly discharged to activate battery until battery voltage is low. Bypass must be in normal condition, the battery capacity should be above 25%.
	Battery self-check test	UPS transfer to battery discharge mode to test if the battery is normal. Bypass must be in normal condition, the battery capacity should be above 25%.
	Stop testing	Manually Stop the test including maintenance test, capacity test
UPS system information	Monitoring software version	Monitoring software version
	Rectified software version	Rectifier software version
	Inverted software version	Inverter software version
	Serial No.	The serial NO set when delivered from the factory
	Rated information	System rated information

3.5 Event List

The following Table3.7 gives events of UPS History Log

Table 3.7 List of History Log

String Sequence	LCD Display	Explanation
1	Load On UPS-Set	Load On UPS
2	Load On Bypass-Set	Load On Bypass
3	No Load-Set	No Load (Output Power Lost)
4	Battery Boost-Set	Charger is Boosting Battery Voltage
5	Battery Float-Set	Charger is Floating Battery Voltage
6	Battery Discharge-Set	Battery is Discharging
7	Battery Connected-Set	Battery cables Connected
8	Battery Not Connected-Set	Battery cables Disconnected.
9	Maintenance CB Closed-Set	Maintenance CB is Closed
10	Maintenance CB Open-Set	Maintenance CB is Open
11	EPO-Set	Emergency Power Off
12	Less-Set	Valid Inverter capacity is less than the load

		capacity
13	Less-Clear	Incident above disappears
14	Generator Input-Set	Generator as the AC Input Source
15	Generator Input-Clear	Incident above disappears
16	Utility Abnormal-Set	Utility (Grid) Abnormal
17	Utility Abnormal-Clear	Incident above disappears
18	Bypass Sequence Error-Set	Bypass voltage Sequence is reverse
19	Bypass Sequence Error-Clear	Incident above disappears
20	Bypass Volt Abnormal-Set	Bypass Voltage Abnormal
21	Bypass Volt Abnormal-Clear	Incident above disappears
22	Bypass Module Fail-Set	Bypass Module Fail
23	Bypass Module Fail-Clear	Incident above disappears
24	Bypass Overload-Set	Bypass Over load
25	Bypass Overload-Clear	Incident above disappears
26	Bypass Overload Tout-Set	Bypass Over Load Timeout
27	Byp Overload Tout-Clear	Incident above disappears
28	Byp Freq Over Track-Set	Bypass Frequency Over Track Range
29	Byp Freq Over Track-Clear	Incident above disappears
30	Exceed Tx Times Lmt-Set	Transfer times (from inverter to bypass) in 1 hour exceed the limit.
31	Exceed Tx Times Lmt-Clear	Incident above disappears
32	Output Short Circuit-Set	Output shorted Circuit
33	Output Short Circuit-Clear	Incident above disappears
34	Battery EOD-Set	Battery End Of Discharge
35	Battery EOD-Clear	Incident above disappears
36	Battery Test-Set	Battery Test Starts
37	Battery Test OK-Set	Battery Test OK
38	Battery Test Fail-Set	Battery Test fails
39	Battery Maintenance-Set	Battery Maintenance Starts
40	Batt Maintenance OK-Set	Battery maintenance succeeds
41	Batt Maintenance Fail-Set	Battery maintenance fails
42	Rectifier Fail-Set	Rectifier Fails
43	Rectifier Fail-Clear	Incident above disappears
44	Inverter Fail-Set	Inverter Fail
45	Inverter Fail-Clear	Incident above disappears
46	Rectifier Over Temp.-Set	Rectifier Over Temperature
47	Rectifier Over Temp.-Clear	Incident above disappears
48	Fan Fail-Set	Fan Fail
49	Fan Fail-Clear	Incident above disappears
50	Output Overload-Set	Output Over Load
51	Output Overload-Clear	Incident above disappears
52	Inverter Overload Tout-Set	Inverter Over Load Timeout

53	INV Overload Tout-Clear	Incident above disappears
54	Inverter Over Temp.-Set	Inverter Over Temperature
55	Inverter Over Temp.-Clear	Incident above disappears
56	On UPS Inhibited-Set	Inhibit system transfer from bypass to UPS (inverter)
57	On UPS Inhibited-Clear	Incident above disappears
58	Manual Transfer Byp-Set	Transfer to bypass manually
59	Manual Transfer Byp-Set	Cancel to bypass manually
60	Esc Manual Bypass-Set	Escape transfer to bypass manually command
61	Battery Volt Low-Set	Battery Voltage Low
62	Battery Volt Low-Clear	Incident above disappears
63	Battery Reverse-Set	Battery pole (positive and negative are reverse)
64	Battery Reverse-Clear	Incident above disappears
65	Inverter Protect-Set	Inverter Protect (Inverter Voltage Abnormal or Power Back feed to DC Bus)
66	Inverter Protect-Clear	Incident above disappears
67	Input Neutral Lost-Set	Input Grid Neutral Lost
68	Bypass Fan Fail-Set	Bypass Module Fan Fail
69	Bypass Fan Fail-Clear	Incident above disappears
70	Manual Shutdown-Set	Manually Shutdown
71	Manual Boost Charge-Set	Manually Battery Boost Charge
72	Manual Float Charge-Set	Manually Battery Float Charge
73	UPS Locked-Set	Inhibit to shut down the UPS
74	Parallel Cable Error-Set	Parallel cable in error
75	Parallel Cable Error-Clear	Incident above disappears
76	Lost N+X Redundant	Lost N+X Redundant
77	N+X Redundant Lost-Clear	Incident above disappears
78	EOD Sys Inhibited	System is inhibited to supply after the battery is EOD (end of discharging)
79	Power Share Fail-Set	Power share is not in balance
80	Power Share Fail-Clear	Incident above disappears
81	Input Volt Detect Fail-Set	Input Voltage is abnormal
82	Input Volt Detect Fail-Clear	Incident above disappears
83	Battery Volt Detect Fail-Set	Battery Voltage is abnormal
84	Batt Volt Detect Fail-Clear	Incident above disappears
85	Output Volt Fail-Set	Output Voltage is abnormal
86	Output Volt Fail-Clear	Incident above disappears
87	Outlet Temp. Error-Set	Outlet Temperature is abnormal
88	Outlet Temp. Error-Clear	Incident above disappears
89	Input Curr Unbalance-Set	Input current is not balance
90	Input Curr Unbalance-Clear	Incident above disappears
91	DC Bus Over Volt-Set	DC bus over Voltage

92	DC Bus Over Volt-Clear	Incident above disappears
93	REC Soft Start Fail-Set	Rectifier soft start fails
94	REC Soft Start Fail-Clear	Incident above disappears
95	Relay Connect Fail-Set	Relay in open circuit
96	Relay Connect Fail-Clear	Incident above disappears
97	Relay Short Circuit-Set	Relay shorted
98	Relay Short Circuit-Clear	Incident above disappears
99	No Inlet Temp. Sensor-Set	The inlet temperature sensor is not connected or abnormal
100	No Inlet Temp Sensor-Clear	Incident above disappears
101	No Outlet Temp. Sensor-Set	The Outlet temperature sensor is not connected or abnormal
102	No Outlet Temp. Sensor-Clear	Incident above disappears
103	Inlet Over Temp.-Set	Inlet over temperature
104	Inlet Over Temp.-Clear	Incident above disappears

Chapter 4 Operations

4.1 UPS Start-up

The UPS must be started up by commissioning engineer after the completeness of installation. The steps below must be followed :

1. Ensure all the circuit breakers are open.
2. Close the output circuit breaker (CB) and then the input CB and the system starts initializing. If the system has dual inputs, close both of the breakers.
3. The LCD in front of the cabinet is lit up. The system enters the home page, as shown in Fig.3-2.
4. Notice the energy bar in the home page, and pay attention to the LED indicators. The rectifier flashes indicating the rectifier is starting up. The LED indicators are listed below in Table 4.1.

Table 4.1 Rectifier starting up

Indicator	Status	Indicator	Status
Rectifier	green flashing	Inverter	off
Battery	red	Load	off
Bypass	off	Status	red

5. After 30S, the rectifier indicator goes steady green, presenting the finishing of rectification and bypass static switch closes then the inverter is starting up. The LED indicators are listed below in Table.4.2.

Table 4.2 Inverter starting up

Indicator	Status	Indicator	Status
Rectifier	green	Inverter	green flashing
Battery	red	Load	green
Bypass	green	Status	red

6. The UPS transfers from the bypass to inverter after the inverter goes normal. The LED indicators are listed below in Table 4.3.

Table 4.3 Supplying the load

Indicator	Status	Indicator	Status
Rectifier	green	Inverter	green
Battery	red	Load	green
Bypass	off	Status	red

7. The UPS is in Normal Mode. Close the battery circuit breakers and the UPS starts charging the battery. The LED indicators are listed below in Table 4.4.

Table 4.4 Normal mode

Indicator	Status	Indicator	Status
Rectifier	green	Inverter	green
Battery	green	Load	green
Bypass	off	Status	green

8. The starting up done.



Note

- When the system starts, the stored setting will be loaded.
- Users can browse all incidents during the process of the starting up by checking the menu Log.

4.2 Procedure for Switching between Operation Modes

4.2.1 Switching the UPS into Battery Mode from Normal Mode

The UPS transfers to Battery model immediately after input circuit breaker disconnects from the utility.

4.2.2 Switching the UPS into Bypass Mode from Normal Mode

Follow the path by selecting the icon of  and then select **Manual Byp** to transfer the system to Bypass Mode.



Warning

Ensure the bypass is working normally before transferring to bypass mode. Or it may cause failure.

4.2.3 Switching the UPS into Normal Mode from Bypass Mode

Follow the path by selecting the icon of  and then select **Manual ESC**, the system transfer to Normal Mode

Note

Normally, the system will transfer to the Normal mode automatically. This function is used when the frequency of the bypass is over track and when the system needs to transfer to Normal mode by manual.

4.2.4 Switching the UPS into Maintenance Bypass Mode from Normal Mode

These following procedures can transfer the load from the UPS inverter output to the maintenance bypass supply, which is used for maintaining the bypass module.

1. Transfer the UPS into Bypass Mode following section 4.2.2.
2. Open the battery breaker and close the maintenance bypass breaker. And the load is powered through maintenance bypass and static bypass.
3. Open the input bypass and output breakers.
4. The load is powered through maintenance bypass.

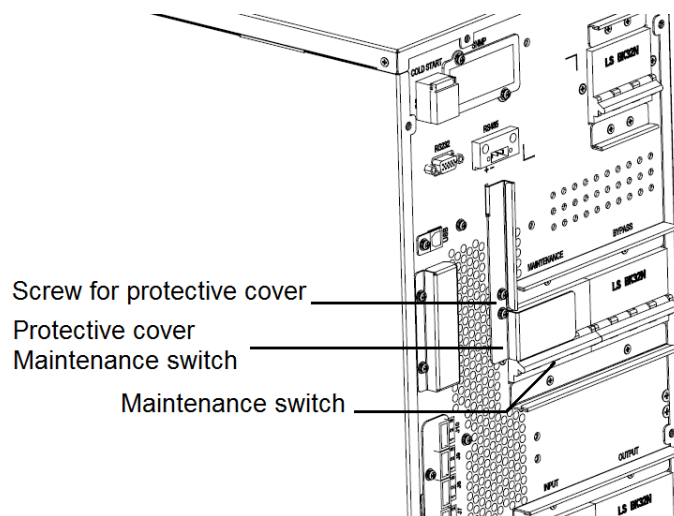

Fig.4-2 The cover of maintenance bypass breaker

**Warning**

Once the cover on the maintenance bypass breaker is removed, the system will transfer to bypass mode automatically.

**Warning**

Before making this operation, confirm the messages on LCD display to be sure that bypass supply is regular and the inverter is synchronous with it, so as not to risk a short interruption in powering the load.



**Danger**

Even with the LCD turned off, the terminals of input and output may be still energized. If you need to maintain the UPS, wait for 10 minutes to let the DC bus capacitor fully discharge before removing the cover.

4.2.5 Switching the UPS into Normal Mode from Maintenance Bypass Mode

These following procedures can transfer the load from the Maintenance Bypass Mode to inverter output.

1. After finish of maintenance, close the output, bypass breakers and bypass static switch will be turned on in 30S after the LED screen goes on, the bypass indicator goes green and the load is powered through maintenance bypass and static bypass.
2. Turn off the maintenance bypass switch and fix the protection cover, and then the load is powered through bypass static switch.



3. Select the icon of  and select  to turn on the inverter.
4. After 60S, the system transfers to Normal Mode.

**Warning**

The system will stay on bypass mode until the cover of maintenance bypass breaker is fixed.

4.3 Battery Maintenance

If the battery is not discharged for a long time, it is necessary to test the condition of the battery.

Enter the menu , as is shown in Fig.4-3 and select the icon , the system transfers into the Battery mode for discharging. The system will discharge the batteries until the alarm of "Battery low voltage" is given Users can stop the discharging by the "Stop Test"

icon .

With the icon of , batteries will be discharged for about 30 seconds, and then re-transfer to normal mode.

BACK ⇐	FUNCTION ⇐⇒	END ⇒
ManualByp/Esc	Batt. Test	
Fault Clear	Maint Test	
Manual INV	Stop Test	

Fig.4.3 Battery maintenance

4.4 EPO

The EPO button located in the operator control and display panel (with cover to avoid disoperation, see Fig.4-5) is designed to switch off the UPS in emergency conditions (e.g., fire, flood, etc.). To achieve this, just press the EPO button, and the system will turn off the rectifier, inverter and stop powering the load immediately (including the inverter and bypass output), and the battery stops charging or discharging.

If the input utility is present, the UPS control circuit will remain active; however, the output will be turned off. To completely isolate the UPS, users need to open the external mains input supply to the UPS.



Warning

When the EPO is triggered, the load is not powered by the UPS. Be careful to use the EPO function.

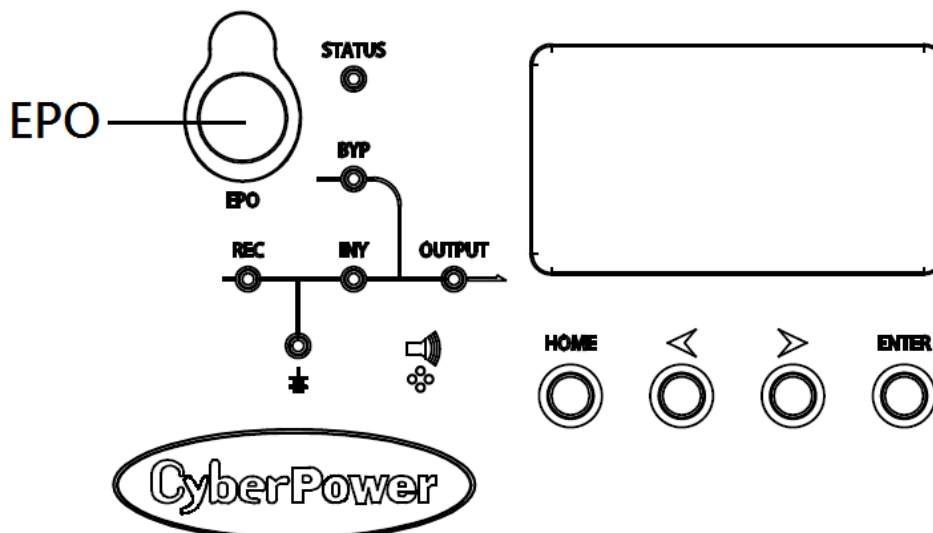

Fig .4-5 EPO Button

4.5 Installation of Parallel Operation System

4.5.1 Parallel system diagram

Up to four UPS could be paralleled, with a diagram as shown in Fig.4-6.

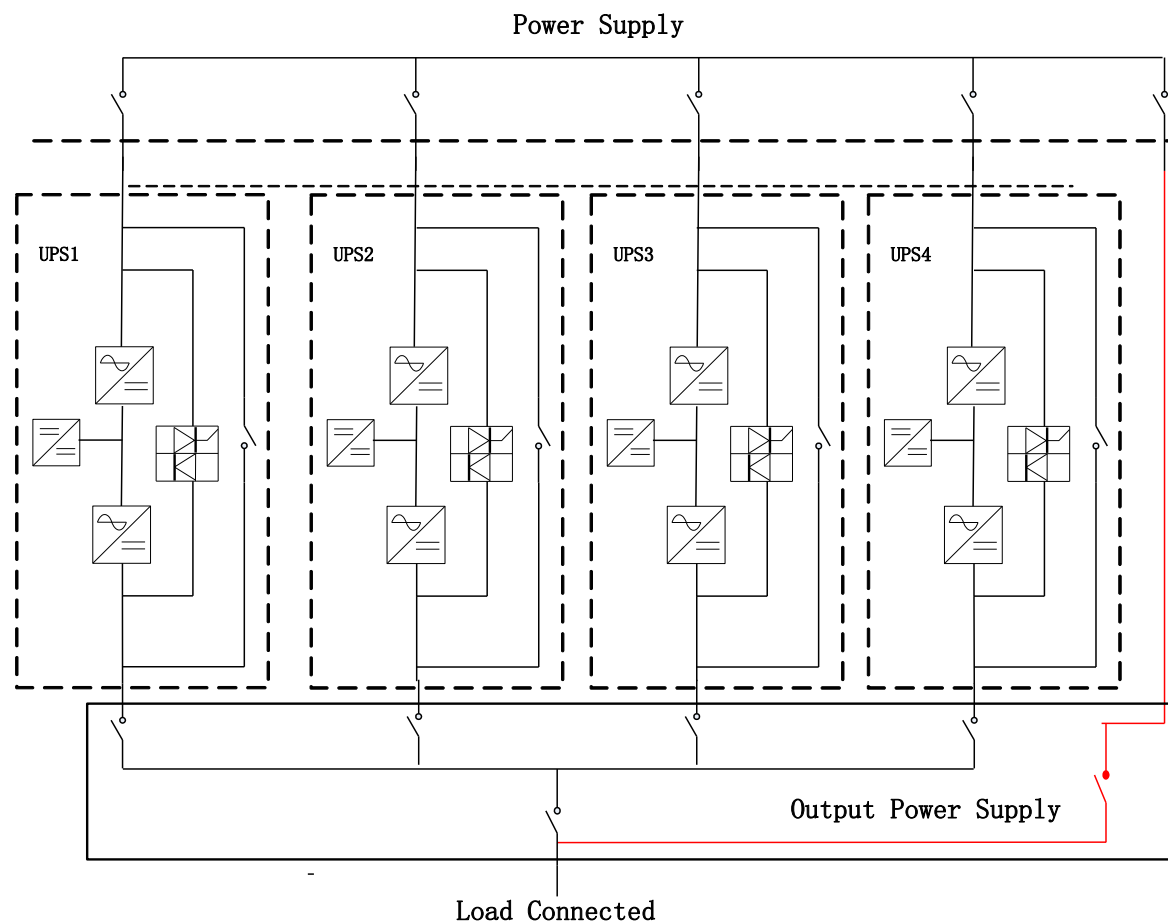

Fig. 4-6 Parallel diagram

The parallel board is located at the back of the UPS cabinet, as is shown in Fig.4-7.

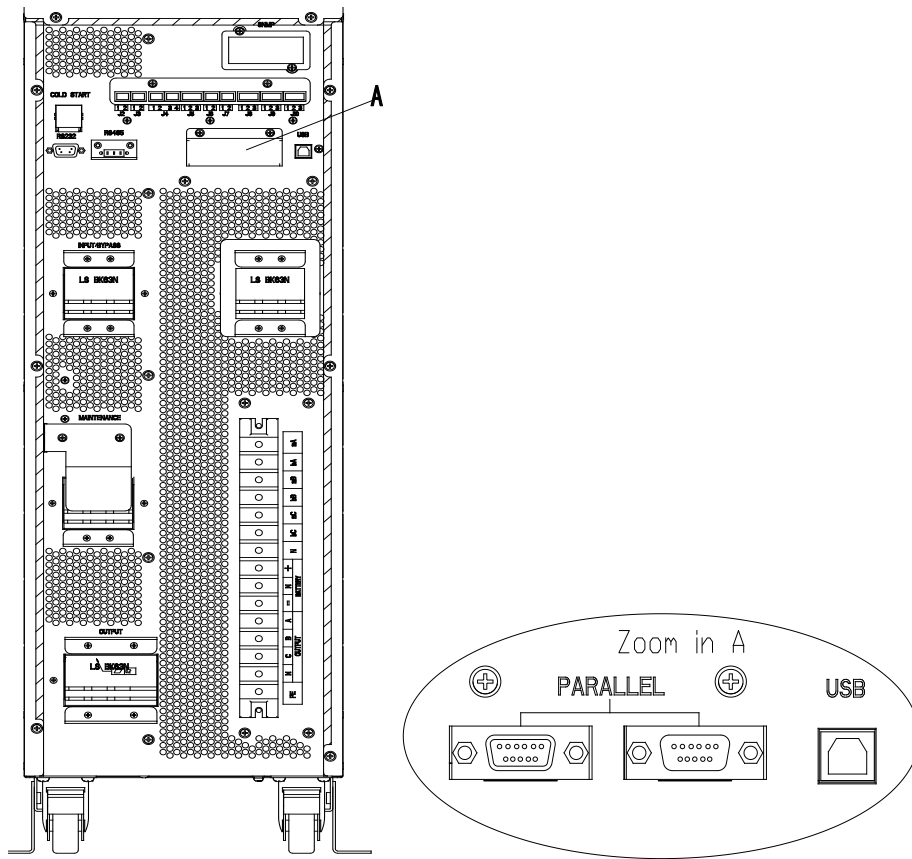

Fig.4-7 Location of the Parallel board

All the parallel cables are designed to be shielded and double insulated, and are connected between the UPS to form a loop as shown below in Fig. 4-8.

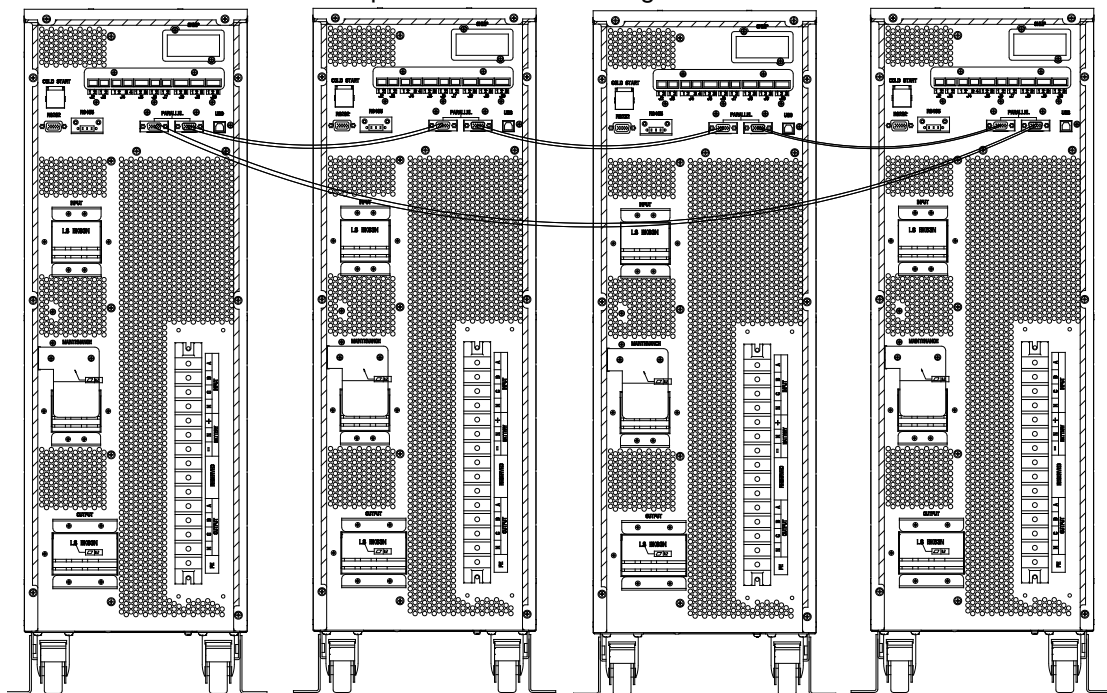

Fig.4-8 Parallel connection

4.5.2 Parallel system setting

Parallel system connection

For field installation, please connect the cables according to Fig.4-6 and Fig.4-8.

In order to assure that all units are equally utilized and to comply with relevant wiring rules, the following requirements apply:

1. All units shall be of the same rating and must be connected to the same bypass source.
2. The bypass and the main input sources must be referenced to the same neutral potential.
3. Any RCD (Residual Current detecting device), if installed, must be of an appropriate setting and located upstream of the common neutral bonding point. Alternatively, the device must monitor the protective earth currents of the system. Refer to the High Leakage Current Warning in the first part of this manual.
4. The outputs of all UPS must be connected to a common output bus.

Parallel system software setting

To change the parallel system setting, please follow the steps below.

1. With the monitoring software from manufacturer, select the page of “Service Setting” as below,

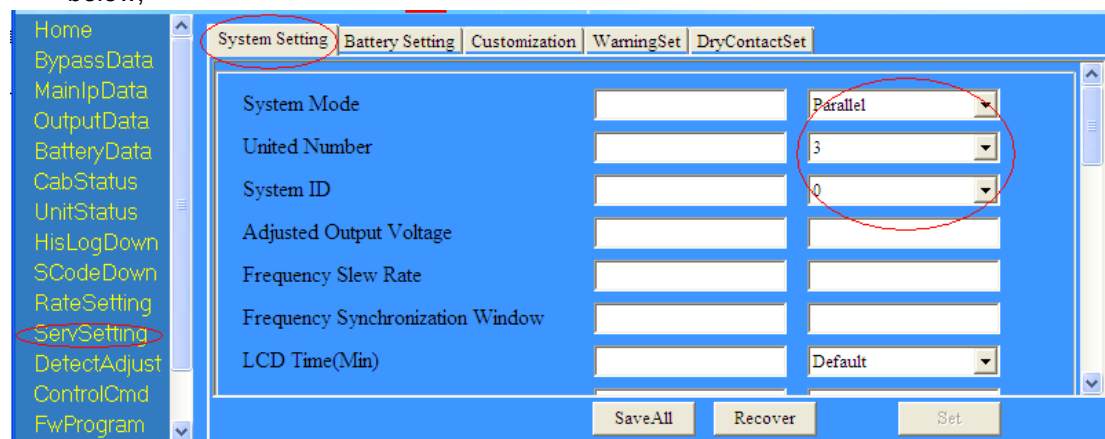

Set “System Mode” to “Parallel”, and set the “United Number” to the number of units in parallel. For the setting of system ID with a system of 3 units in parallel, for example, set the number from 0 to 2 for these 3 units accordingly.

Restart the UPS when finish the setting and press the button of “Set”. Here the software setting is done. Ensure all the output parameters must be set the same.

Parallel system jumper setting

There are different setting of the jumpers on the parallel board and control board for different parallel system.

The location of connectors on parallel board is shown in Fig.4-11 and control board in Fig.4-12.

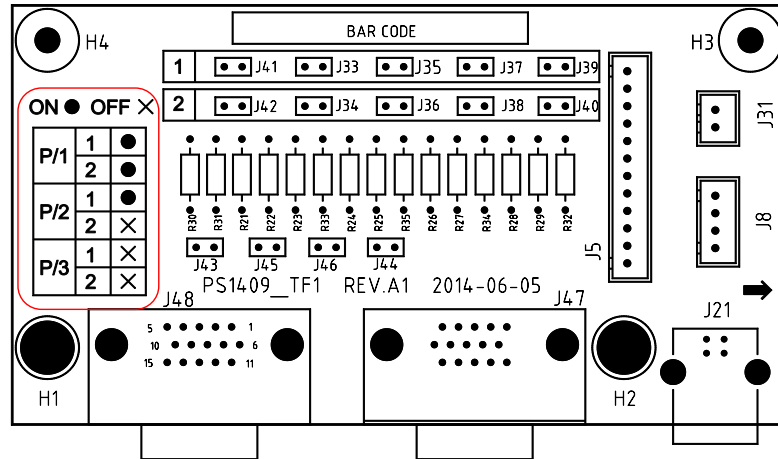
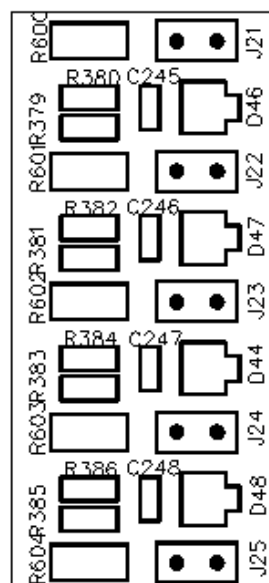
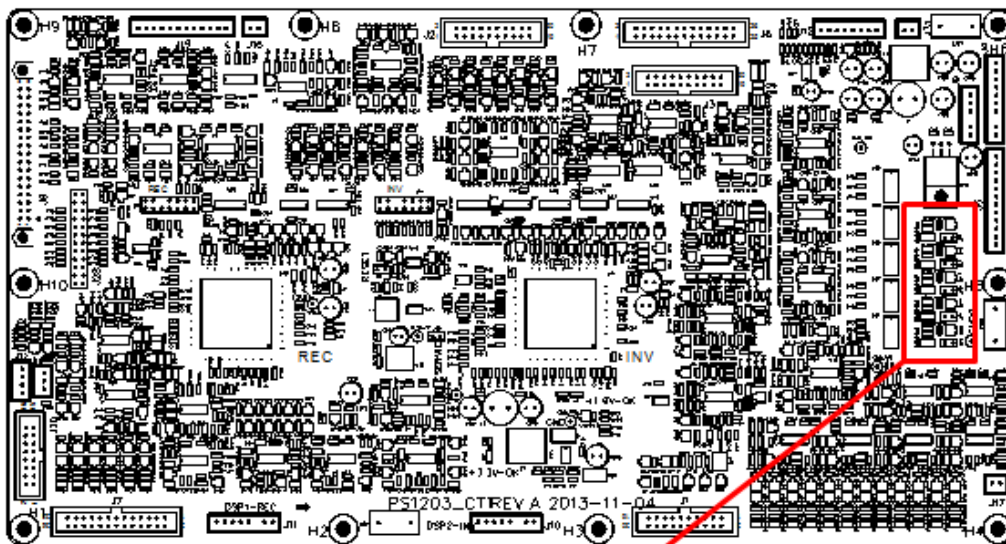

Fig.4-11 Connectors on Parallel board (PS1409_TF1)



Zoom in jumper connectors

Fig.4-12 Connectors on Control board (PS1203_CT1)

1. Parallel boards settings
 - A. For single UPS, no need parallel board. When a parallel board is installed, connectors of J33 to J42 should be shorted by the jumpers.
 - B. For 2 UPS in parallel, short the connectors of J33/J35/J37/J39/J41 by jumpers on each board, keep connectors of J34/J36/J38/J39/J42 open
 - C. For 3 or 4 UPS in parallel, keep connectors of J33-J42 open.
2. Control boards settings

The control board is named as PS1203_CT1.

For single UPS, keep the J21-J25 shorted by jumpers

For parallel, keep all the connectors J21-J25 open. As is shown in Fig.4-12.

Note: The connectors not mentioned keep them untouched.

When all the connection and settings are finished, follow the steps below for the operation of parallel system setup.

1. Close the output and input breaker of the first unit. Wait for the startup of bypass static switch and rectifier, about 90 seconds later; the system will transfer to normal mode. Check if there is any alarm on LCD and verify the output voltage is correct or not.
2. Turn on the second unit as the same operation with the first one; the unit will join the parallel system automatically.
3. Turn on the rest units one by one, and check the information on LCD.
4. Verify the load sharing with a certain load applied.

Chapter 5 Maintenance

This chapter introduces UPS maintenance, including the maintenance instructions of power module and monitoring bypass module and the replacement method of dust filter.

5.1 Precautions

1. Only certified engineers are authorized to maintain the UPS.
2. The components or PCBs should be disassembled from top to bottom, so as to prevent any inclination from high gravity center of the cabinet.
3. To ensure the safety before maintaining, measure the voltage between operating parts and the earth with multi-meter to ensure the voltage is lower than hazardous voltage, i.e. DC voltage is lower than 60Vdc, and AC maximum voltage is lower than 42.4Vac.
4. Wait 10 minutes before opening the cover of the power module or the bypass after pulling out from the Cabinet.

5.2 Instruction for Maintaining UPS

For the maintenance of the UPS, please refer to chapter 4.2.4 for the instruction to transfer to maintenance bypass mode. After maintenance, re-transfer to normal mode according to chapter 4.2.5.

5.3 Instruction for Maintaining Battery string

For the Lead-Acid maintenance free battery, when maintenance the battery according to requirements, battery life can be prolonged. The battery life is mainly determined by the following factors:

1. Installation. The battery should be placed in dry and cool place with good ventilation. Avoid direct sunlight and keep away from heat source. When installing, ensure the correct connection to the batteries with same specification.
2. Temperature. The most suitable storage temperature is 20 °C to 25°C. The battery life will be shortened if the battery is used under high temperature or in deep discharging status. Refer to product manual for details.
3. Charging/discharging current. The best charging current for the lead-acid battery is 0.1C .The maximum current for the battery can be 0.3C.The suggested discharging current is 0.05C-3C.
4. Charging voltage. In most of the time, the battery is in standby state. When the utility is normal, the system will charge the battery in boost mode (Constant voltage with maximum limited) to full and then transfers to the state of float charge.
5. Discharge depth. Avoid deep discharging; which will greatly reduce the life time of the battery. When the UPS runs in battery mode with light load or no load for a long time, it will cause the battery to deep discharge.
6. Check periodically. Observe if any abnormality of the battery, measure if the voltage of each battery are in balance. Discharge the battery periodically.



Warning

Daily inspection is very important!

Check and confirm the battery connection is tightened regularly, and make sure there is no abnormal heat generated from the battery.



Warning

If a battery has leakage or is damaged, it must be replaced, stored in a container resistant to sulfuric acid and disposed of in accordance with local regulations.

The waste lead-acid battery is a kind of hazardous waste and is one of the major contaminants controlled by government.

Therefore, its storage, transportation, use and disposal must comply with the national or local regulations and laws about the disposal of hazardous waste and waste batteries or other standards.

According to the national laws, the waste lead-acid battery should be recycled and reused, and it is prohibited to dispose of the batteries in other ways except recycling. Throwing away the waste lead-acid batteries at will or other improper disposal methods will cause severe environment pollution, and the person who does this will bear the corresponding legal responsibilities.

5.3.1 Installation of internal battery

For 15kVA to 20kVA standard UPS, internal battery and the cables within the battery string are not provided as standard; if required, please contact your local agency.

For 15-20kVA UPS, 40 pieces of 7AH/9AH batteries can be installed.,

There are 40 batteries of to be installed, which are divided into 4 layers.Fig.5-1 shows the installation of battery of the 15-20kVA standard UPS.

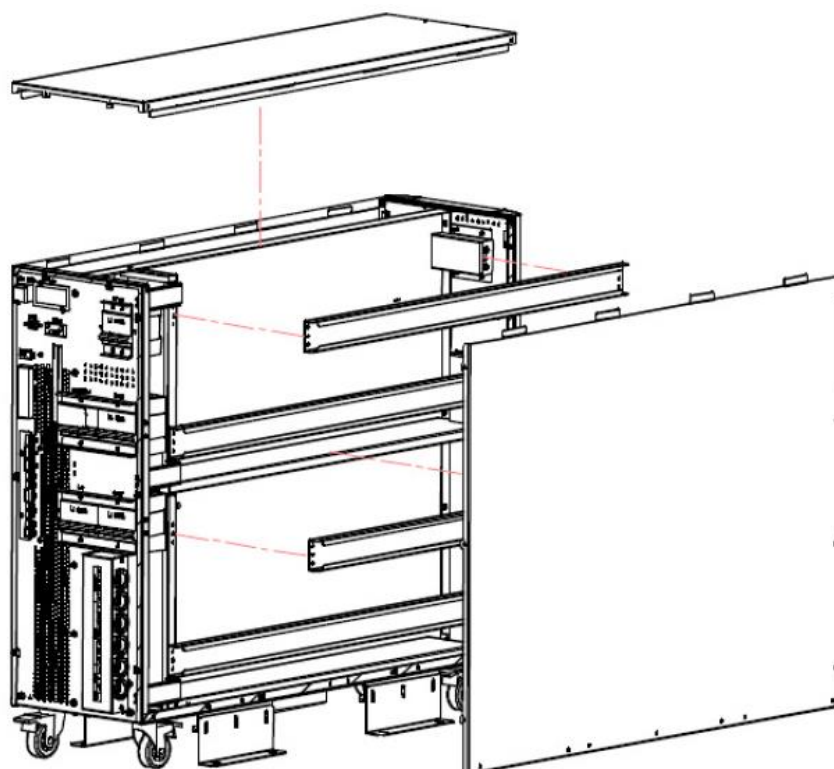

1. Dismantle the covers and crossbeams

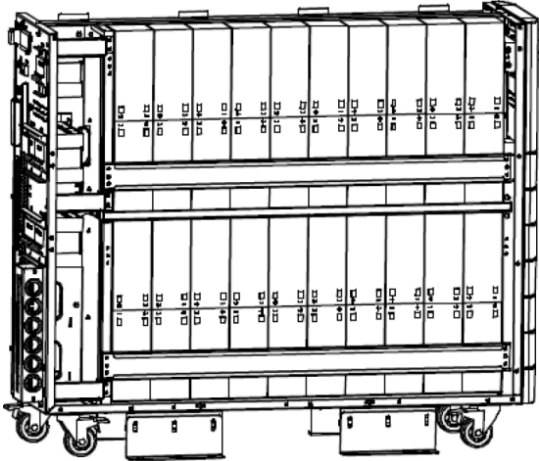

2. Install battery and fix the crossbeams

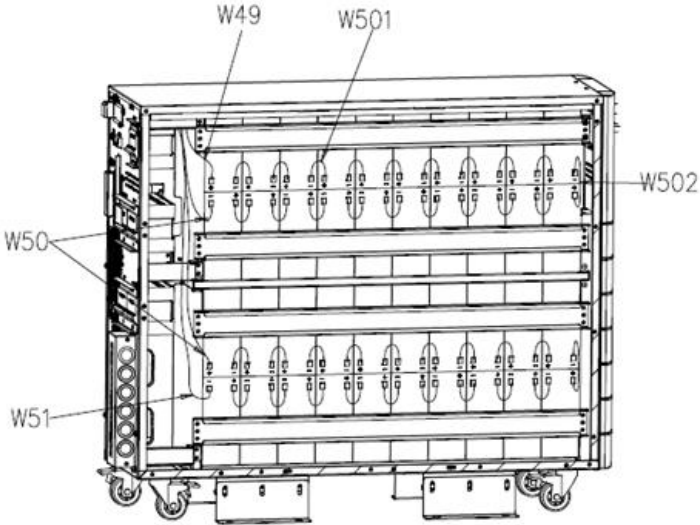

3. Connect the battery cable according to the series number

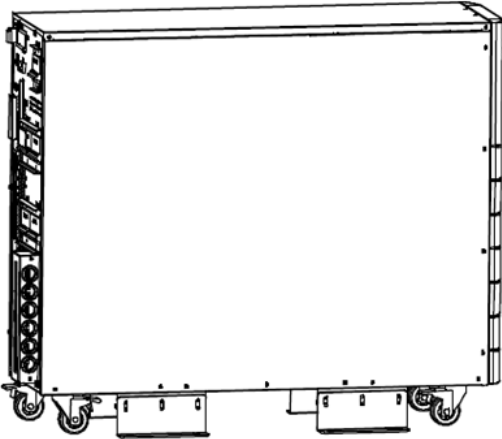

4. Recover the cover

Fig.5-1 Installation of inner battery for15/20K standard UPS



Warning

Make sure the polarity of the battery is correct according to the diagrams above. Test and confirm the battery voltage before connecting to the main circuit.

Chapter 6 Product Specification

This chapter provides the specifications of the product, including environmental characteristics mechanical characteristics and electrical characteristics.

6.1 Applicable Standards

The UPS has been designed to conform to the following European and international standards:

Table 6.1 Compliance with European and International Standards

Item	Normative reference
General safety requirements for UPS used in operator access areas	EN50091-1-1/IEC62040-1-1/AS 62040-1-1
Electromagnetic compatibility (EMC) requirements for UPS	EN50091-2/IEC62040-2/AS 62040-2 (C3)
Method of specifying the performance and test requirements of UPS	EN50091-3/IEC62040-3/AS 62040-3 (VFI SS 111)

Note

The above mentioned product standards incorporate relevant compliance clauses with generic IEC and EN standards for safety (IEC/EN/AS60950), electromagnetic emission and immunity (IEC/EN/ AS61000 series) and construction (IEC/EN/AS60146 series and 60950).



Warning

This product conform the EMC requirements for UPS in Category C3 and it is not suitable for medical equipment.

6.2 Environmental Characteristics

Table 6.2 Environmental Characteristics

Item	Unit	Requirements
Acoustic noise level at 1 meter	dB	58dB @ 100% load, 55dB @ 45% load
Altitude of Operation	m	≤1000,load derated 1% per 100m from 1000m and 2000m
Relative Humidity	%	0-95 ,Non condensing
Operating Temperature	°C	0-40,Battery life is halved for every 10°C increase above 20°C
UPS Storage Temperature	°C	-40-70

6.3 Mechanical Characteristic

Table 6.3 Mechanical Characteristics for Cabinet

Model	Unit	15/20KE-C	15/20KEBC-C	15/20KEBCWOB-C
Dimension WxDxH	mm	250*660*530	250*840*715	250*840*715
Weight	kg	31	164	52

Color	N/A	BLACK,RAL 7021
Protection Level IEC (60529)	N/A	IP20

6.4 Electrical Characteristics

6.4.1 Electrical Characteristics (Input Rectifier)

Table 6.5 Rectifier AC input Mains)

Item	Unit	Parameter
Grid System	\	3 Phases + Neutral + Ground
Rated AC Input Voltage	Vac	380/400/415 (three-phase and sharing neutral with the bypass input)
Rated Frequency	Vac	50/60Hz
Input voltage range	Vac	304~478Vac (Line-Line),full load 228V~304Vac (Line-Line),load decrease linearly according to the min phase voltage
Input Frequency range	Hz	40~70
Input Power factor	PF	>0.99
THDI	THDI%	<3% (full Linear Load)

6.4.2 Electrical Characteristics (Intermediate DC Link)

Table 6.6 Battery

Items	Unit	Parameters
Battery bus voltage	Vdc	Rated: $\pm 240V$
Quantity of lead-acid cells	Nominal	40=[1 battery(12V)] ,240=[1 battery(2V)]
Float charge voltage	V/cell (VRLA)	2.25V/cell(selectable from 2.2V/cell~2.35V/cell) Constant current and constant voltage charge mode
Temperature compensation	mV/°C/cl	3.0(selectable:0~5.0)
Ripple voltage	%	≤ 1
Ripple current	%	≤ 5
Equalized charge voltage	VRLA	2.4V/cell(selectable from : 2.30V/cell~2.45V/cell) Constant current and constant voltage charge mode
Final discharging voltage	V/cell (VRLA)	1.65V/cell(selectable from: 1.60V/cell~1.750V/cell) @0.6C discharge current 1.75V/cell (selectable from: 1.65V/cell~1.8V/cell) @0.15C discharge current (EOD voltage changes linearly within the set range according to discharge current)
Battery Charge	V/cell	2.4V/cell(selectable from : 2.3V/cell~2.45V/cell) Constant current and constant voltage charge mode
Battery Charging Power Max Current	kW	10%* UPS capacity (selectable from : 1~20% * UPS capacity)

6.4.3 Electrical Characteristics (Inverter Output)

Table 6.7 Inverter Output (To critical load)

Item	Unit	Value
Rated capacity	kVA	15/20
Rated AC voltage	Vac	380/400/415 (Line-Line)
Rated Frequency	Hz	50/60
Frequency Regulation	Hz	50/60Hz±0.1%
Voltage precision	%	±1.5(0~100% linear load)
Overload	\	110%, 60min; 125%, 10min; 150%, 1min; >150%, 200ms
Synchronized Range	Hz	Settable, ±0.5Hz ~ ±5Hz, default ±3Hz
Synchronized Slew Rate	Hz	Settable, 0.5Hz/S ~ 3Hz/S, default 0.5Hz/S
Output Power Factor	PF	0.8
Transient Response	%	<5% for step load (20% - 80% -20%)
Transient recovery		< 30ms for step load (20% - 100% -20%)
Output Voltage THDu		<1% from 0% to 100% linear load <6% full non-linear load according to IEC/EN62040-3

6.4.4 Electrical Characteristics (Bypass Mains Input)

Table 6.8 Bypass Mains Input

Item	Unit	Value
Rated AC voltage	Vac	380/400/415 (three-phase four-wire and sharing neutral with the bypass)
Overload	%	125% Long term operation; 125%~130% for 10min; 130%~150% for 1min; 150%~400% for 1s; >400% ,less than 200ms
Current rating of neutral cable	A	1.7×In
Rated frequency	Hz	50/60
Switch time (between bypass and inverter)	ms	Synchronized transfer: 0ms
Bypass voltage range	%	Settable, default -20%~+15% Upper limit: +10%, +15%, +20%, +25% Lower limit: -10%, -15%, -20%, -30%, -40%
Bypass frequency range	%Hz	Settable, ±1Hz, ±3Hz, ±5Hz
Synchronized Range	Hz	Settable ±0.5Hz~±5Hz, default ±3Hz

6.5 Efficiency

Table 6.9 Efficiency

Rated power(kVA)	Unit	15/20kVA
Overall efficiency		
Normal mode(dual conversion)	%	>95
Battery discharging efficiency (battery at nominal voltage 480Vdc and full-rated linear load)		
Battery mode	%	>94.5

6.6 Display and Interface

Table 6.10 Display and Interface

Display	LED + LCD
Interface	Standard:RS232, RS485 Option: SNMP ,Dry Contact