

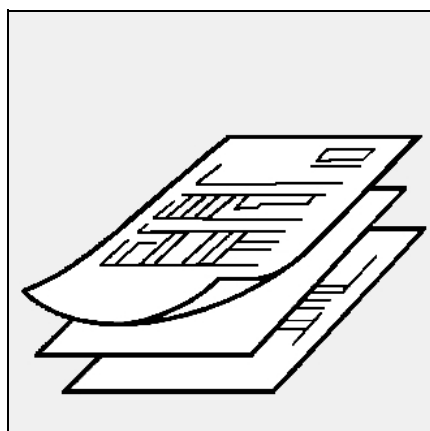

NC12, NC16, NC21 H101  
NC12, NC16, NC21 H201



**Données techniques**  
**Brûleurs fuel** ..... 3-8

FR

**Dati tecnici**  
**Bruciatori di gasolio**..... 3-8

IT



**Datos técnicos**  
**Quemadores de gasóleo**..... 3-8

ES

**Technical data**  
**Fuel oil burners**..... 3-8

EN

**Technische Daten**  
**Leichtölbrenner** ..... 3-8

DE



**Технические характеристики на  
жидкотопливные горелки** ..... 3-8

RU

**Pièces de rechange**  
**Pezzi di ricambio**  
**Piezas de recambio**  
**Spare parts list**  
**Ersatzteilliste**  
**Список запчастей** ..... 9-15



**Schémas électrique et hydraulique**  
**Schemi elettrico e idraulico**  
**Esquema eléctrico y hidráulico**  
**Electric and hydraulic diagrams**  
**Elektro- und Hydraulikschema**  
**Электрические и гидравлические схемы**17-21





**Principaux composants / Caractéristiques d'utilisation**  
**Componenti principali / Caratteristiche d'impiego**  
**Componentes principales / Características de utilización**  
**Main components / Characteristics of use**  
**Wichtigste Komponenten / Betriebsdaten**  
**Основные компоненты / Рабочие характеристики**

**Principaux composants:**

- Coffret de commande et sécurité:
  - 1 allure SH113
  - 2 allures SH 213
- Détecteur de flamme:
  - Cellule photorésistante MZ 770S
- Moteur de ventilation et de pompe :
  - monophasé 230V, 50Hz,
  - NC12/16 : 160W 2850 tr/min
  - condensateur: 5µF/440V
  - NC21 : 130W 2900 tr/min
  - condensateur: 6µF/430V
- Turbine de ventilation:
  - NC12: Ø146x52
  - NC16/21: Ø160x52
- Transformateur d'allumage:
  - EBI 2 x 7,5kV
- Commande volet d'air:
  - 1 allure manuelle
  - 2 allures servomoteur STA 4,5
- Pompe fuel avec électrovanne(s) :
  - 1 allure : AS 47D, 50l/h,
  - gavage p max 2 bar
  - 2 allures : AT2 45D, 60l/h,
  - gavage p max 2 bar

**Componenti principali**

- Programmatore di comando e di sicurezza:
  - monostadio SH 113
  - bistadio SH 213
- Rilevatore di fiamma :
  - Cellula fotoresistenza MZ 770 S
- Motore del ventilatore e pompa :
  - monofase 230V, 50Hz,
  - NC12/16 : 160W 2850 giri/min
  - condensatore: 5µF/440V
  - NC21 : 130W 2900 giri/min
  - condensatore: 6µF/430V
- Turbina del ventilatore:
  - NC12: Ø146x52
  - NC16/21: Ø160x52
- Trasformatore d'accensione:
  - EBI 2 x 7,5kV
- Comando serranda aria:
  - monostadio manuale
  - bistadio servomotore STA 4,5
- Pompa gasolio con elettrovalvola(e):
  - monostadio AS 47 D, 50l/h
  - (in sovralimentazione: p max 2 bar);
  - AT2 45 D, 60l/h
  - (in sovralimentazione: p max 2 bar)
  - bistadio
  - (in sovralimentazione: p max 2 bar)

**Principales componentes**

- Cajetín de control y seguridad:
  - 1 etapa SH 113
  - 2 etapas SH 213
- Detector de llama:
  - Célula fotorresistente MZ 770 S
- Motor de ventilación y bomba:
  - monofásico 230V, 50Hz,
  - NC12/16 : 160W 2850 t/min
  - condensador: 5µF/440V
  - NC21 : 130W 2900 t/min
  - condensador: 6µF/430V
- Turbina de ventilación:
  - NC12: Ø146x52
  - NC16/21: Ø160x52
- Transformador de encendido:
  - EBI 2 x 7,5kV
- Control de la trampilla de aire:
  - 1 etapa manual
  - 2 etapas servomotor STA 4,5
- Bomba gasóleo con electroválvula(s):
  - 1 etapa AS 47 D, 50l/h,
  - cebado p máx. 2 bares
  - 2 etapas AT2 45 D, 60l/h,
  - cebado p máx. 2 bares

**Caractéristiques d'utilisation**

Température ambiante:  
 - d'utilisation: -5 ... 40°C  
 - de stockage: - 20 ...70°C  
 Tension / Fréquence:  
 - 230 VAC -15...+10% - 50Hz±1%  
 monophasé  
 Degré de protection: IP 21  
 ▲ Dans le cas d'une alimentation électrique sans neutre à la terre, installer un transformateur d'isolement de 2A/500 VA.

**Caratteristiche d'impiego**

Temperatura ambiente :  
 - d'utilizzazione : -5 ...40° C  
 - di stoccaggio : -20 ...70° C  
 Tensione / Frequenza :  
 - 230 VAC -15...+10% - 50 Hz±1%  
 monofase  
 Grado di protezione : IP 21  
 ▲ In caso di alimentazione elettrica senza neutro collegato a terra, installare un trasformatore d'isolamento di 2A/500 VA.

**Características de utilización**

Temperatura ambiente :  
 - de utilización : - 5 ...40° C  
 - de almacenamiento : - 20 ...70° C  
 Tensión eléctrica / Frecuencia :  
 - 230 VAC -15...+10% - 50 Hz±1%  
 monofásico  
 Grado de protección : IP 21  
 ▲ En caso de alimentación eléctrica sin neutro a tierra instalar un transformador de aislamiento de 2A/500 VA.

### Main components

- Control and safety unit:
  - 1 stage SH 113
  - 2 stages SH 213
- Flame detector:  
Photocell MZ 770 S
- Fan and pump motor:  
single-phase 230V, 50Hz,  
NC12/16: 160W 2850 rpm  
capacitor: 5µF/440V  
NC21: 130W 2900 rpm  
capacitor: 6µF/430V
- Ventilation turbine:  
NC12: Ø146x52  
NC16/21: Ø160x52
- Firing transformer:  
EBI 2 x 7,5kV
- Air flap control:
  - 1 stage manual
  - 2 stages servomotor STA 4,5
- Fuel-oil pump with solenoid valve(s):
  - 1 stage: AS 47D, 50l/h,  
boost pressure max 2bar
  - 2 stages: AT2 45D, 60l/h,  
boost pressure max 2bar

### Wichtigste Komponenten:

- Feuerungsautomat:
  - 1-stufig SH 113
  - 2-stufig SH 213
- Flammenüberwachung:  
Fotowiderstand MZ 770 S
- Gebälse- und Pumpenmotor:  
einphasig 230V, 50Hz,  
NC12/16: 160W 2850 min<sup>-1</sup>  
Kondensator: 5µF/440V  
NC21: 130W 2900 min<sup>-1</sup>  
Kondensator: 6µF/430V
- Lüfterrad:  
NC12: Ø146x52  
NC16/21: Ø160x52
- Zündtrafo:  
EBI 2 x 7,5kV
- Luftklappensteuerung:
  - 1-stufig Handbedienung
  - 2-stufig Stellantrieb: STA 4,5
- Heizölpumpe mit Magnetventilen:
  - 1-stufig AS 47D, 50l/h,  
Aufladung p max. 2 bar
  - 2-stufig AT2 45 D, 60l/h  
Aufladung p max. 2 bar

### Основные компоненты

- Прибор управления:
  - 1 ступень SH 113
  - 2 ступени SH 213
- Контроль факела:  
фотосопротивление MZ 770 S
- Двигательвоздуходувки:  
однофазный 230 В, 50 Гц,  
NC 12/16: 160 Вт 2850 об./мин.  
конденсатор: 5мкФ/440В  
NC 21: 130 Вт 2900 об./мин.  
конденсатор: 6мкФ/430В
- Лопасть воздуходувки:  
NC12: Ø 146 x 52  
NC16/21: Ø 160 x 52
- Трансформатор розжига:  
EBI 2 x 75 кВ
- Управление воздушной заслонкой:
  - 1 ступень ручное управление
  - 2 ступени серводвигатель STA4,5
- Жидкотопливный насос с магнитными клапанами:
  - 1 ступень AS 47D, 50 л/ч,  
загрузка р макс. 2 бара
  - 2 ступени AT2 45D, 60 л/ч,  
загрузка р макс. 2 бара

### Characteristics of use

- Ambient temperature :  
- for use : - 5... 40° C  
- for storage : - 20... 70° C  
Voltage / Frequency :  
- 230 VAC -15...+10% - 50 Hz<sup>±1%</sup>  
single-phase  
Protection level : IP 21  
▲With an electrical power supply without an earthed neutral, install a 2A/500 VA isolation transformer

### Betriebsdaten

- Umgebungstemperatur :  
- Betriebstemperatur : -5...40°C  
- Lagerungstemperatur : -20...70°C  
Spannung/Frequenz :  
- 230 VAC -15...+10% - 50 Hz<sup>±1%</sup>  
einphasig  
Schutzart : IP 21  
▲Bei einer Stromversorgung ohne geerdeten Nullleiter einen Isoliertrafo mit 2A/500 VA installieren.

### Рабочие характеристики

- Температура окружающей среды:  
- Рабочая температура: -5...40°C  
- Температура хранения: -20...70°C  
Напряжение / частота:  
- 230 В переменный ток  
-15...+10% - 50 Гц<sup>±1%</sup> однофазный  
Вид защиты: IP 21  
▲При электропитании без заземленной нейтрали смонтируйте изолирующий трансформатор с 2А/500 ВА.

**Courbes de puissance**  
**Curve di potenza**  
**Diagramas de potencia**  
**Power graphs**  
**Arbeitsfelder**  
**Рабочие поля**

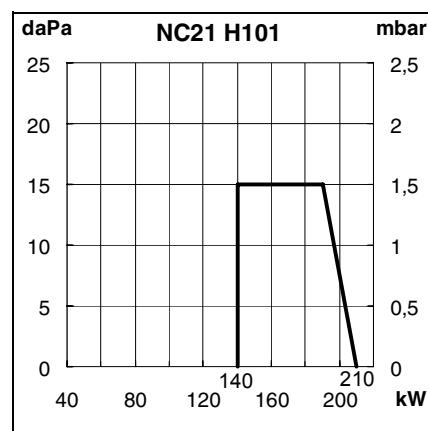
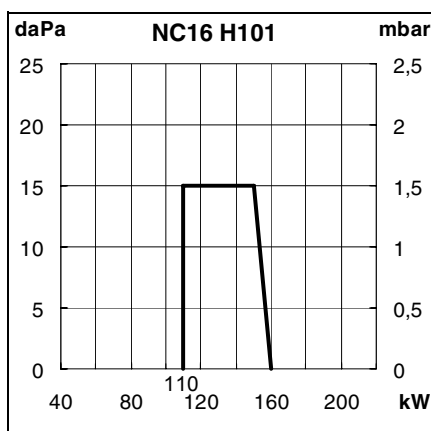
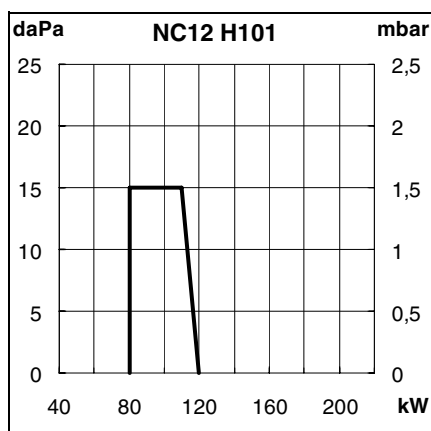

Puissance kW Potenza kW Potencia kW Power kW Leistung kW Мощность кВт	NC12 H101		NC16 H101		NC21 H101	
	min МИН.	max МАКС.	min МИН.	max МАКС.	min МИН.	max МАКС.
Brûleur (kW)	80	120	110	160	140	210
Min. allumage (kW)	—	—	—	—	—	—
Générateur (kW)	74	110	101	147	129	193
Débit fuel domestique (kg/h)	6,7	10,1	9,3	13,5	11,8	17,7
Q à 20°C et 6 mm <sup>2</sup> /s (cSt) Hi = 11,86 kW h/kg						
Bruciatore (kW)	80	120	110	160	140	210
Min. accensione (kW)	—	—	—	—	—	—
Generatore (kW)	74	110	101	147	129	193
Portata di gasolio (kg/h)	6,7	10,1	9,3	13,5	11,8	17,7
Q a 20°C e 6 mm <sup>2</sup> /s (cSt) Hi = 11,86 kW h/kg						
Quemador (kW)	80	120	110	160	140	210
Min. encendido (kW)	—	—	—	—	—	—
Generador (kW)	74	110	101	147	129	193
Caudal gasóleo doméstico (kg/h)	6,7	10,1	9,3	13,5	11,8	17,7
Q a 20°C y 6 mm <sup>2</sup> /s (cSt) Hi = 11,86 kW h/kg						
Burner (kW)	80	120	110	160	140	210
Min. ignition (kW)	—	—	—	—	—	—
Generator (kW)	74	110	101	147	129	193
FO flow rate (kg/h)	6,7	10,1	9,3	13,5	11,8	17,7
Q at 20°C and 6 mm <sup>2</sup> /s (cSt) Hi = 11.86 kW h/kg						
Brenner (kW)	80	120	110	160	140	210
Min. Zündleistung (kW)	—	—	—	—	—	—
Kessel (kW)	74	110	101	147	129	193
Ölmassenstrom (kg/h)	6,7	10,1	9,3	13,5	11,8	17,7
Q bei 20°C und 6 mm <sup>2</sup> /s (cSt) Hi = 11,86 kW h/kg						
Горелка (kW)	80	120	110	160	140	210
Мин. мощность розжига (kW)	—	—	—	—	—	—
Котел (kW)	74	110	101	147	129	193
Масса потока жидкого топлива (kg/h)	6,7	10,1	9,3	13,5	11,8	17,7
Q при 20°C и 6 мм <sup>2</sup> /с. (сст) НИЖН. = 11,86 кВтч/кг						

**Courbes de puissance**  
**Curve di potenza**  
**Diagramas de potencia**  
**Power graphs**  
**Arbeitsfelder**  
**Рабочие поля**

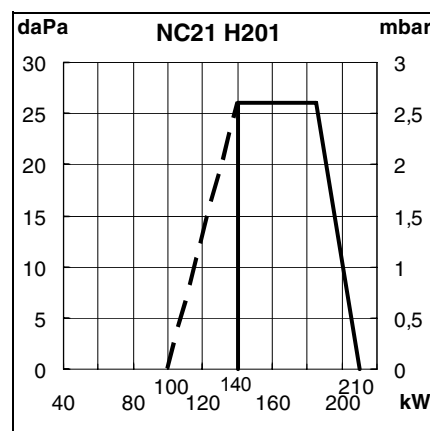
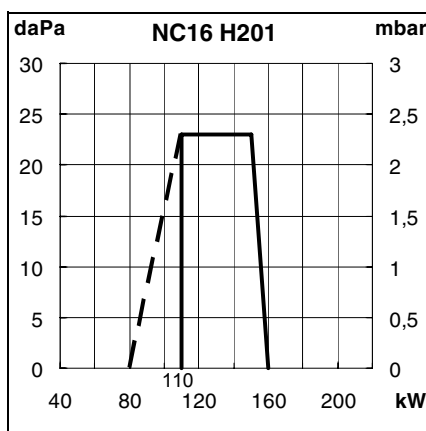
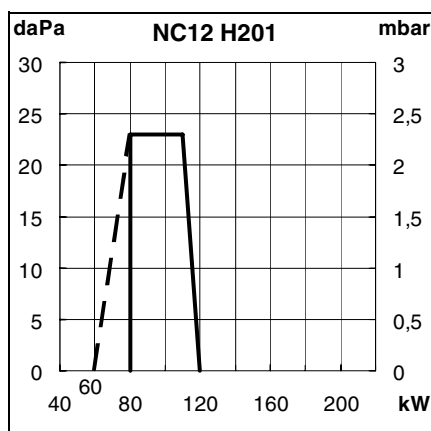

Puissance kW Potenza kW Potencia kW Power kW Leistung kW Мощность кВт	NC12 H201		NC16 H201		NC21 H201	
	min МИН.	max МАКС.	min МИН.	max МАКС.	min МИН.	max МАКС.
Brûleur (kW)	80	120	110	160	140	210
Min. allumage (kW)	60	—	80	—	100	—
Générateur (kW)	74	110	101	147	129	193
Débit fuel domestique (kg/h)	6,7	10,1	9,3	13,5	11,8	17,7
Q à 20°C et 6 mm <sup>2</sup> /s (cSt) Hi = 11,86 kW h/kg						
Bruciatore (kW)	80	120	110	160	140	210
Min. accensione (kW)	60	—	80	—	100	—
Generatore (kW)	74	110	101	147	129	193
Portata di gasolio (kg/h)	6,7	10,1	9,3	13,5	11,8	17,7
Q a 20°C e 6 mm <sup>2</sup> /s (cSt) Hi = 11,86 kW h/kg						
Quemador (kW)	80	120	110	160	140	210
Min. encendido (kW)	60	—	80	—	100	—
Generador (kW)	74	110	101	147	129	193
Caudal gasóleo doméstico (kg/h)	6,7	10,1	9,3	13,5	11,8	17,7
Q a 20°C y 6 mm <sup>2</sup> /s (cSt) Hi = 11,86 kW h/kg						
Burner (kW)	80	120	110	160	140	210
Min. ignition (kW)	60	—	80	—	100	—
Generator (kW)	74	110	101	147	129	193
FO flow rate (kg/h)	6,7	10,1	9,3	13,5	11,8	17,7
Q at 20°C and 6 mm <sup>2</sup> /s (cSt) Hi = 11.86 kW h/kg						
Brenner (kW)	80	120	110	160	140	210
Min. Zündleistung (kW)	60	—	80	—	100	—
Kessel (kW)	74	110	101	147	129	193
Ölmassenstrom (kg/h)	6,7	10,1	9,3	13,5	11,8	17,7
Q bei 20°C und 6 mm <sup>2</sup> /s (cSt) Hi = 11,86 kW h/kg						
Горелка (kW)	80	120	110	160	140	210
Мин. мощность розжига (kW)	60	—	80	—	100	—
Котел (kW)	74	110	101	147	129	193
Масса потока жидкого топлива (kg/h)	6,7	10,1	9,3	13,5	11,8	17,7
Q при 20°C и 6 мм <sup>2</sup> /с. (сст) НИЖН. = 11,86 кВтч/кг						

**Encombremet Dimensions  
Dimensioni d'ingombro  
Dimensiones Medidas  
Space requirements and dimensions  
Maßbild und Abmessungen  
Чертеж с размерами**

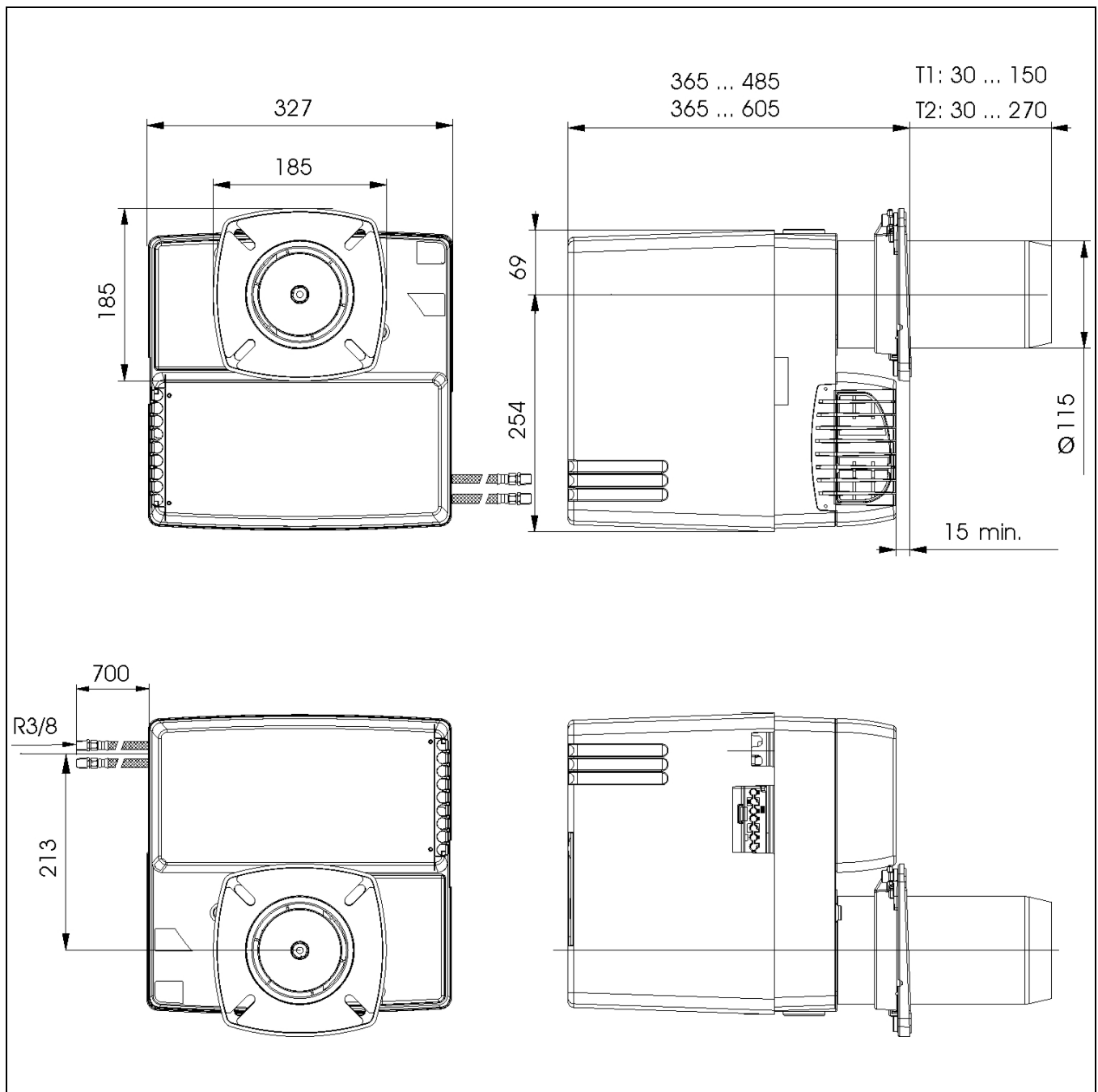

**Pour l'implantation volute en bas :**  
Lire les informations complémentaires au paragraphe "Installation" montage du brûleur.

**Per l'installazione con la voluta verso il basso :**  
Leggere le informazioni complementari al paragrafo "Installazione", montaggio del bruciatore.

**Para colocar la voluta hacia abajo :**  
Leer las informaciones complementarias en el párrafo "Instalación" montaje del quemador.

**For setting-up with the spiral at bottom :**  
Read the additional information in the "Assembly" paragraph of the burner installation instructions.

**Für den Einbau mit nach unten gerichtetem Lüfterrad :**  
Die ergänzenden Informationen des Kapitels "Installation" 'Montage des Brenners beachten.

**Для монтажа с лопастью воздуходуки внизу :**  
Ознакомьтесь с дополнительной информацией раздела "Установка" в инструкции по эксплуатации.

**Encombremet Dimensions**  
**Dimensioni d'ingombro**  
**Dimensiones Medidas**  
**Space requirements and dimensions**  
**Maßbild und Abmessungen**  
**Чертеж с размерами**

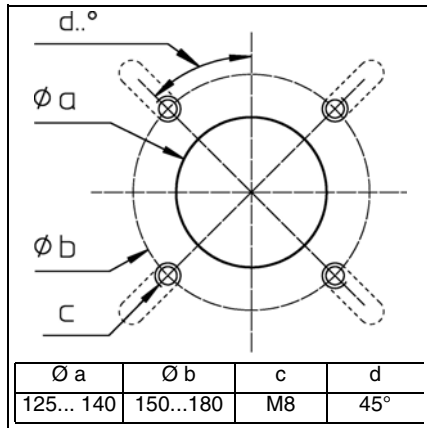

**Encombremet et dimensions**

Respecter une distance libre minimum de 0,6 mètre de chaque côté du brûleur pour permettre les opérations de maintenance.

**Ventilation chaufferie**

Le volume d'air neuf requis est de 1,2 m<sup>3</sup>/kWh produit au brûleur.

**Dimensioni d'ingombro**

Lasciare uno spazio libero minimo di 0,6 metri su ogni lato del bruciatore per consentire le operazioni di manutenzione.

**Ventilazione locale caldaia**

La portata dell'aria di ricambio del locale deve essere almeno di 1,2 m<sup>3</sup>/kWh bruciatore.

**Dimensiones y medidas**

Respetar una distancia libre mínima de 0,6 metros a ambos lados del quemador para permitir las operaciones de mantenimiento.

**Ventilación calentador**

El volumen de aire nuevo requerido es de 1,2 m<sup>3</sup>/kWh producido en el quemador.

**Space requirements and dimensions**

Leave a space of at least 0.6 metres on each side of the burner for maintenance purposes.

**Boiler-house ventilation**

Volume of fresh air required is 1.2 m<sup>3</sup>/kWh produced at the burner.

**Maßbild und Abmessungen**

Für Servicearbeiten ist ein freier Abstand von min. 0,6 m auf jeder Seite des Brenners sicherzustellen.

**Heizraumbelüftung**

Die nötige Frischluftzufuhr beträgt 1,2 m<sup>3</sup>/kWh am Brenner.

**Чертеж с размерами**

Для теххода с каждой стороны горелки должно быть оставлено свободное место как минимум 0,6 м.

**Вентиляция котельного помещения**

Подача свежего воздуха должна составлять 1,2 м<sup>3</sup>/кВтч мощности горелки.





**Pièces de rechange  
Pezzi di ricambio  
Piezas de recambio  
Spare parts list  
Ersatzteilliste  
Список запчастей**

**NC12, NC16, NC21 H101  
NC12, NC16, NC21 H201**



NC12 H101 2,25 G	T1	13 017 164
NC12 H101 2,25 G	T2	13 017 165
NC16 H101 2,75 G	T1	13 017 168
NC16 H101 2,75 G	T2	13 017 169
NC21 H101 3,50 G	T1	13 015 050
NC21 H101 3,50 G	T2	13 015 051
NC12 H201 1,50 G	T1	13 017 166
NC12 H201 1,50 G	T2	13 017 167
NC16 H201 2,25 G	T1	13 017 170
NC16 H201 2,25 G	T2	13 017 171
NC21 H201 2,75 G	T1	13 015 052
NC21 H201 2,75 G	T2	13 015 053



# NC12, NC16, NC21 H101

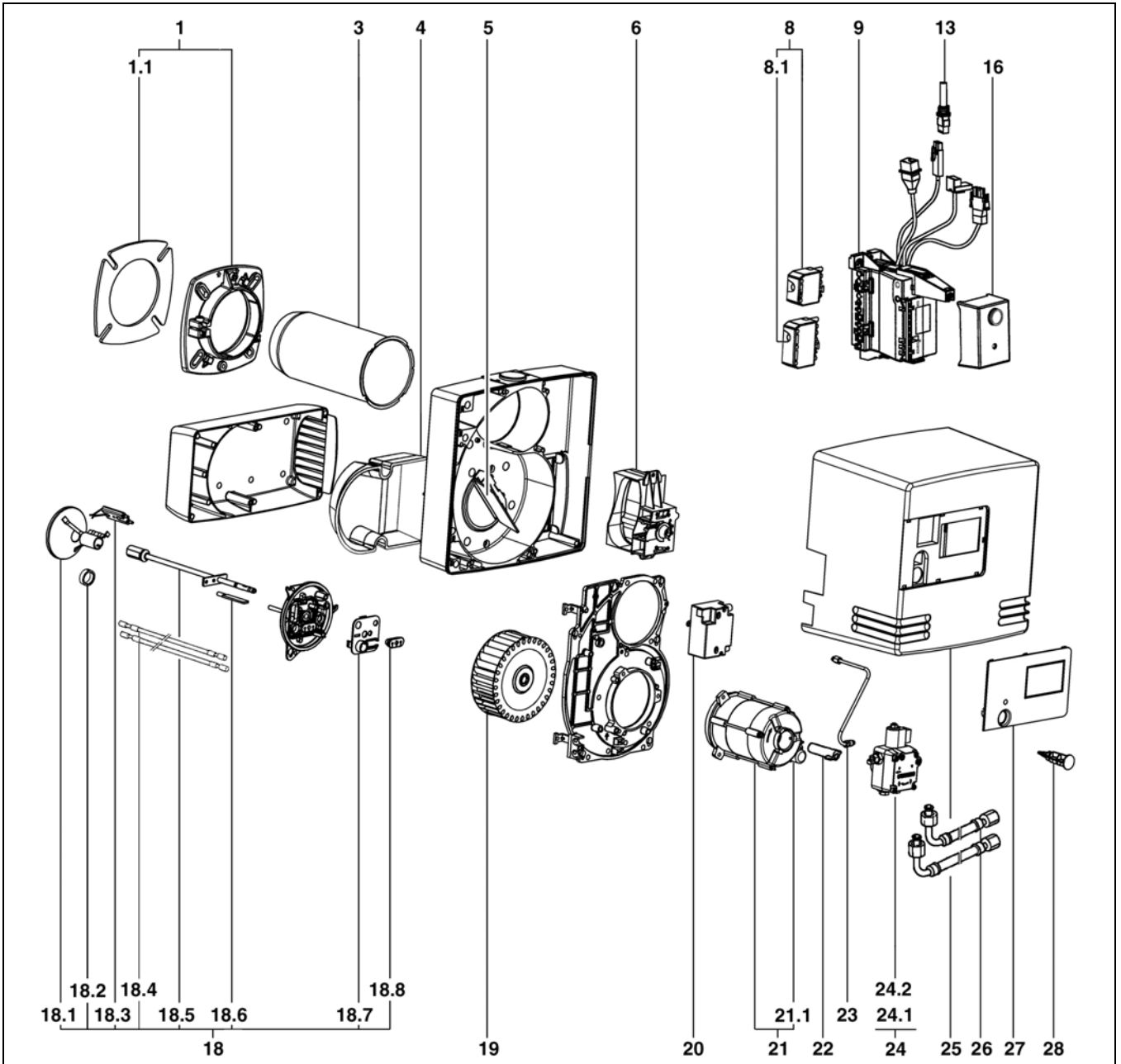

Pos. Поз.	Désignation	Denominazione	Designación	Description	Bezeichnung	Название	Art. Nr. Арт.№
01	Accessoires chaudière	Accessori caldaia	Accesorios caldera	Boiler accessories	Anschlussflansch BG.	Соединительный фланец BG	13 017 361
01.1	Joint façade	Guarnizione	Junta	Boiler front seal	Isolierflansch	Изоляция	13 017 360
03	Embout NC12/16 Ø115/78 T1 T2 x230 x350 NC21 Ø115/100 T1 T2 x230 x350	Imbuto NC12/16 Ø115/78 T1 T2 x230 x350 NC21 Ø115/100 T1 T2 x230 x350	Cañón NC12/16 Ø115/78 T1 T2 x230 x350 NC21 Ø115/100 T1 T2 x230 x350	Blast tube NC12/16 Ø115/78 T1 T2 x230 x350 NC21 Ø115/100 T1 T2 x230 x350	Brennerrohr NC12/16 Ø115/78 T1 T2 x230 x350 NC21 Ø115/100 T1 T2 x230 x350	Жаровая труба NC12/16 Ø115/78 T1 T2 x230 x350 NC21 Ø115/100 T1 T2 x230 x350	13 017 371 13 017 372 13 017 367 13 017 368
04	Isolation phonique	Isolamento fonico	Phonique del aislamiento	Insulation	Isolierung / Luftkasten	Изоляция для воздушной коробки	13 017 369
05	Recyclage d'air NC12 NC16/21	NC12 NC16/21	NC12 NC16/21	Recycling air NC12 NC16/21	Ansaugluftführung NC12 NC16/21	Рециркуляция воздуха NC12 NC16/21	13 017 363 13 017 364
06	Volet d'air complet	Serranda aria	Trampilla de aire	Air flap	Luftklappe BG	Воздушная заслонка BG	13 017 362
08	Prise Wieland 4P +7P.	Presa Wieland 4P +7P.	Toma Wieland 4P +7P.	Wieland plug 4P +7P.	Wieland Stecker 4P +7P.	Штекер Wieland 4 п.+ 7 п.	13 016 496
08.1	Prise Wieland 7P.	Presa Wieland 7P.	Toma Wieland 7P.	Wieland plug 7P.	Wieland Stecker 7P.	Штекер Wieland 7 п.	13 016 494
09	Cassette de raccordement câblée	Cassetta di collegamento	Casete de conexión	Elec. Connection box	Anschlusskasten m. Relaissockel O.Kabel	Клеммная коробка	13 015 685
13	Cellule MZ 770 S	Cellula MZ 770 S	Célula MZ 770 S	Photozell MZ 770 S	Fotozelle MZ 770 S	Фотоэлемент MZ 770 S	13 015 692
16	Coffret fuel SH 113	Programmatore gasolio SH 113	Cajetin gasóleo SH 113	Control unit SH 113	Feuerungsautomat SH 113	Прибор управления SH113	13 015 697
18	Ligne gicleur équipée NC12/16 T1 T2 NC21 T1 T2	Linea porta ugello cpl. NC12/16 T1 T2 NC21 T1 T2	Linea pulverizador cpl. NC12/16 T1 T2 NC21 T1 T2	Nozzle rod cpl. NC12/16 T1 T2 NC21 T1 T2	Düsenstange Kpl. NC12/16 T1 T2 NC21 T1 T2	Линия сопла NC12/16 T1 T2 NNC21 T1 T2	13 017 374 13 017 375 13 017 464 13 017 465
18.1	Déflecteur NC12/16 Ø78/20-6FD NC21 Ø90/20-6FD	Deflettore NC12/16 Ø78/20-6FD NC21 Ø90/20-6FD	Deflector NC12/16 Ø78/20-6FD NC21 Ø90/20-6FD	Turbulator NC12/16 Ø78/20-6F NC21 Ø90/20-6FD	Turbulator NC12/16 Ø78/20-6FD NC21 Ø90/20-6FD	Турбулятор NC12/16 Ø78/20-6FD NC21 Ø90/20-6FD	13 015 748 13 015 751
18.2	Anneau de butée			Setting keeper ring	Einstellungsring		13 018 403
18.3	Electrode allu. NC12/16 NC21	Elettrodo di accensione NC12/16 NC21	Electrodo de encendido NC12/16 NC21	Ignition electrode NC12/16 NC21	Blockelektrode NC12/16 NC21	Розжиговый электрод NC12/16 NC21	13 015 848 13 015 847
18.4	Câble allumage L625 T1/T2	Cavi d'accensione L625 T1/T2	Cables de encendido L625 T1/T2	Ignition lead L625 T1/T2	Zündkabel L625 T1/T2	Розжиговый кабель L625 T1/T2	13 018 090
18.5	Ligne gicleur L426 L546	Linea porta ugello T1 T2 L426 L546	Linea pulverizador T1 T2 L426 L546	Nozzle assembly T1 T2 L426 L546	Düsenstange T1 T2 L426 L546	Трубка сопла T1 T2 L426 L546	13 017 365 13 017 366
18.6	Règlette graduée	marchio	placa	ruler	Einstellskala	Шкала	13 017 802
18.7	Plaque tableau de bord	Piastrina cruscotto	Placa del tablero de instrumentos	Dashboard plate	Deckplatte	Покрытие	13 016 951
18.8	Passer fil Ø5/9	Passa cavi Ø5/9	Capuchón de goma Ø5/9	Funnel Ø5/9	Kabeldurchführung Ø5/9	Прокладной изолятор кабеля Ø5/9	13 018 139



Pos. Поз.	Désignation	Denominazione	Designación	Description	Bezeichnung	Название	Art. Nr. Арт. №
19	Turbine NC12 Ø146X42 NC16/21 Ø160X52	Ventilatore NC12 Ø146X42 NC16/21 Ø160X52	Turbina NC12 Ø146X42 NC16/21 Ø160X52	Air fan NC12 Ø146X42 NC16/21 Ø160X52	Ventilatorrad NC12 Ø146X42 NC16/21 Ø160X52	Колесо вентилятора NC12 Ø 146 x 52 NC16/21 Ø 160 x 52	13 016 689 13 016 706
20	Transformateur allu. EBI-M 2x7,5kV	Trasformatore d'accens. EBI-M 2x7,5kV	Transformador EBI-M 2x7,5kV	Ignition transfo. EBI-M 2x7,5kV	Zündtrafo EBI-M 2x7,5kV	Трансформатор розжига EBI-M 2x7,5kV	13 016 671
21	Moteur + condensateur NC12 NC16/21	Motore + condensatore NC12 NC16/21	Motor + condensador NC12 NC16/21	Motor + Capacitor NC12 NC16/21	Motor + Kondensator NC12 NC16/21	Двигатель+конденсатор NC12 NC16/21	13 016 369 13 016 368
21.1	Condensateur NC12/16 5µF, 400V NC21 6µF, 400V	Condensatore NC12/16 5µF, 400V NC21 6µF, 400V	Condensador NC12/16 5µF, 400V NC21 6µF, 400V	Capacitor NC12/16 5µF, 400V NC21 6µF, 400V	Kondensator NC12/16 5µF, 400V NC21 6µF, 400V	Конденсатор NC12/16 5µF, 400V NC21 6µF, 400V	13 015 722 13 015 723
22	Accouplement pompe/ moteur	Accoppiamento pompa/ servomotore	Acoplamiento bomba/ motor	Coupling pump/motor	Kupplung Pumpe/Motor	Сцепление насос / двигатель	13 015 526
23	Tube Pompe / ligne gicleur	Tubetto pompa / l.p.u.	Tubo bomba/ linea pulveriz.	Fuel-oil feed tube	Düsenzuleitung	Трубка подачи топлива к соплу	13 017 379
24	Pompe AS47D	Pompa AS47D	Bomba AS47D	Pump AS47D	Pumpe AS47D	Насос AS47D	13 016 262
24.1	Filtre H2O + joint	Filtro + guarnizione	Filtro + junta	Filter inlet	Filtereinsatz + Dichtung- Set	Фильтр + уплотнение в комплекте	13 016 253
24.2	Joint	guarnizione	junta	inlet	Dichtung	Уплотнение	13 016 205
24.3	Bobines	Bobina	Bobina	Magnet coil NC	Magnetspule NC	Магнитная катушка NC	13 015 572
25	Capot orange	Coperchio arancio	Tapa naranja	Orange cover	Schützhaube	Колпак оранжевый	13 017 370
26	Flexible 2x	Tubi flessibili	Latiguillos flexibles	Fuel-oil hose	Olschlauch	Жидкотопливный шланг	13 015 503
27	Plaque frontale NC12 NC16 NC21	Marchio frontale NC12 NC16 NC21	Placa frontal NC12 NC16 NC21	Standard front cover NC12 NC16 NC21	Beschriftungsplatte NC12 NC16 NC21	Маркировочная табличка NC12 NC16 NC21	13 017 381 13 017 382 13 017 383
28	Bouton de réarmement	Pulsante di riarmo	Torta/ cajetín de control	Reset button	Taster / Entriegelung	Деблокирующая кнопка	13 017 380
29	Vis M5x20 / capot	Vite M5x20 / Coperchio	Tornillo M5x20 / Tapa	Screw M5x20 / cover	Schraube M5x20 / Haube		13 018 842

# NC12, NC16, NC21 H201

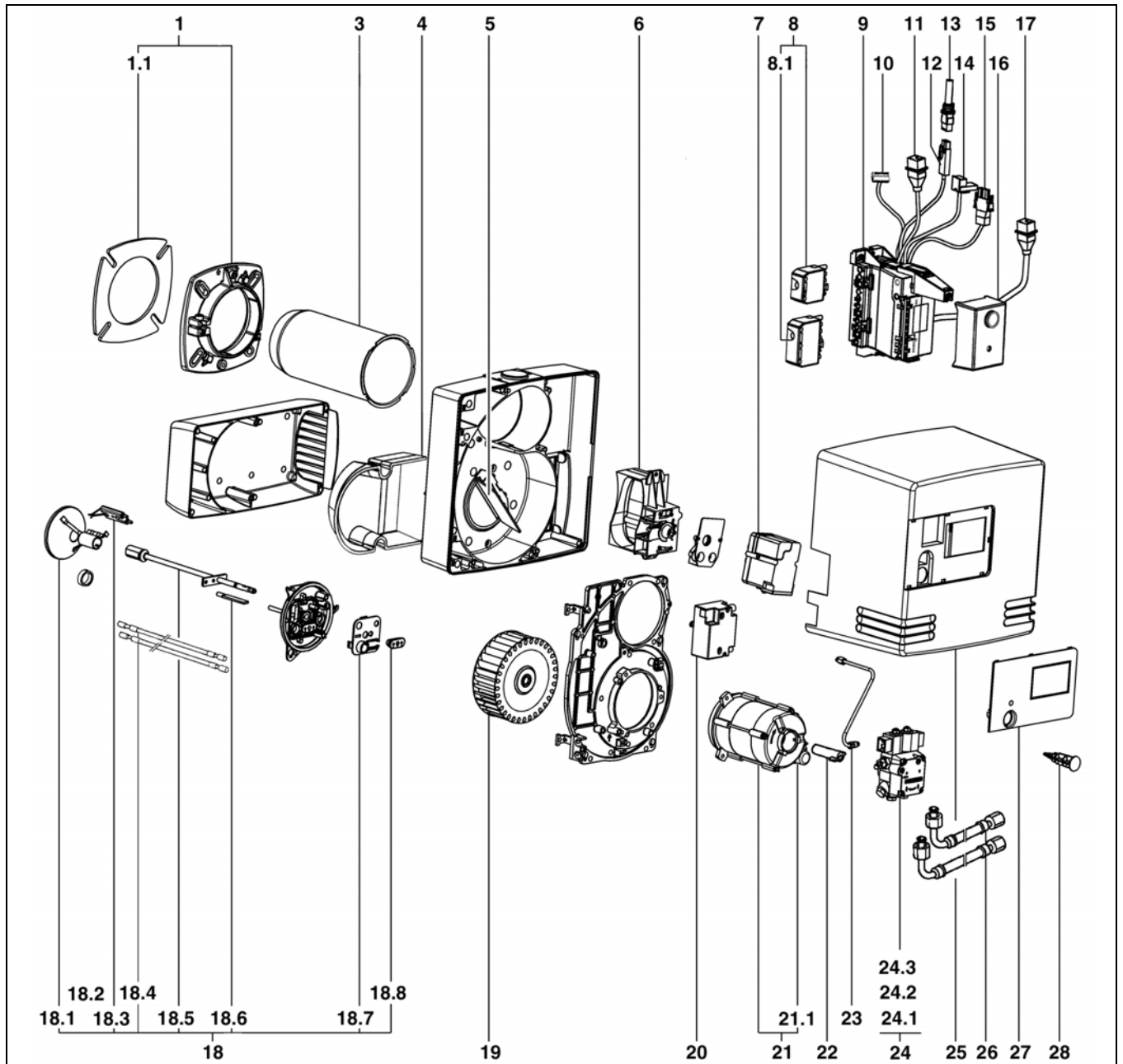

Pos. Pos.	Désignation	Denominazione	Designación	Description	Bezeichnung	Название	Art. Nr. Арт.№
01	Accessoires chaudière	Accessori caldaia	Accesorios caldera	Boiler accessories	Anschlussflansch BG.	Соединительный фланец BG	13 017 361
01.1	Joint façade	Guarnizione	Junta	Boiler front seal	Isolierflansch	Изоляция	13 017 360
03	Embout NC12/16 Ø115/78 T1 T2 x230 x350 NC21 Ø115/100 T1 T2 x230 x350	Imbuto NC12/16 Ø115/78 T1 T2 x230 x350 NC21 Ø115/100 T1 T2 x230 x350	Cañón NC12/16 Ø115/78 T1 T2 x230 x350 NC21 Ø115/100 T1 T2 x230 x350	Blast tube NC12/16 Ø115/78 T1 T2 x230 x350 NC21 Ø115/100 T1 T2 x230 x350	Brennerrohr NC12/16 Ø115/78 T1 T2 x230 x350 NC21 Ø115/100 T1 T2 x230 x350	Жаровая труба NC12/16 Ø115/78 T1 T2 x230 x350 NC21 Ø115/100 T1 T2 x230 x350	13 017 371 13 017 372 13 017 367 13 017 368
04	Isolation phonique	Isolamento fonico	Phonique del aislamiento	Insulation	Isolierung / Luftkasten	Изоляция для воздушной коробки	13 017 369
05	Recyclage d'air NC12 NC16/21	NC12 NC16/21	NC12 NC16/21	Recycling air NC12 NC16/21	Ansaugluftführung NC12 NC16/21	Рециркуляция воздуха NC12 NC16/21	13 017 363 13 017 364
06	Volet d'air complet	Serranda aria	Trampilla de aire	Air flap	Luftklappe BG	Воздушная заслонка BG	13 017 362
07	Servomoteur Berger STA 4,5	Servomoteur	Servomotor	Servomotor	Stellantrieb	Сервопривод Berger	13 016 569
08	Prise Wieland 4P +7P.	Presa Wieland 4P +7P.	Toma Wieland 4P +7P.	Wieland plug 4P +7P.	Wieland Stecker 4P +7P.	Штекер Wieland 4 п.+ 7 п.	13 016 496
08.1	Prise Wieland 7P.	Presa Wieland 7P.	Toma Wieland 7P.	Wieland plug 7P.	Wieland Stecker 7P.	Штекер Wieland 7 п.	13 016 494
09	Cassette de raccordement câblée	Cassetta di collegamento	Casete de conexión	Elec. Connection box	Anschlusskasten m. Relaissockel O.Kabel	Клеммная коробка	13 015 686
10	Prise 9P.+ câble/ servomoteur	Presa 9P.+ cavo / servo.	Toma 9P.+cable/ servomotor	Plug+cable/servomotor	Kabel m. Stecker 9P./Stell.	Кабель со штекером 9п./серводвигатель	13 018 150
11	Câble vanne fuel 1 <sup>ère</sup> all.	Cavo valvola gasolio 1°stadio	Cable válvula 1ª etapa	Cable with plug / Valve (1 <sup>st</sup> stage)	Kabel m. Stecker / Ventil 1 St.	Кабель со штекером клапана (1-ая ступень)	13 018 151
12	Prise D.2P.+ câble / cellule	Presa 2P. + cavo/celula	Toma 2 P. +cable /célula	Plug+cable/Photocell	Stecker+Kabel / Fotozelle	Штекер + кабель фотоэлемента	13 015 614
13	Cellule MZ 770 S	Cellula MZ 770 S	Célula MZ 770 S	Photocell MZ 770 S	Fotozelle MZ 770 S	Фотоэлемент MZ 770 S	13 015 692
14	Prise C.2P.+câble/ transfo.	Presa 2 poli. + cavo trasf.	Toma C. 2P. + cavo/transf.	Cable+plug/ Ignition transfo.	Kabel m. Stecker./ Zündtrafo	Штекер + кабель трансформатора	13 015 638
15	Prise C.3P.+câble/ moteur	Presa 3P.+ cavo / motore	Toma C. 3P.+cable/motor	Plug+cable/motor	Kabel m. Stecker / Motor	Штекер + кабель серводвигателя	13 015 630
16	Coffret fuel SH 213	Programmatore gasolio SH 213	Cajetín gasóleo SH 213	Control unit SH 213	Feuerungsautomat SH 213	Прибор управления SH213	13 015 698
17	Câble vanne fuel 2 <sup>ème</sup> all.	Cavo valvola gasolio 2°stadio	Cable válvula 2ª etapa	Cable with plug / Valve (2 <sup>nd</sup> stage)	Kabel m. Stecker / Ventil 2 St.	Кабель со штекером клапана (2-ая ступень)	13 018 152
18	Ligne gicleur équipée NC12/16 T1 T2 NC21	Linea porta ugello cpl. NC12/16 T1 T2 NC21	Linea pulverizador cpl. NC12/16 T1 T2 NC21	Nozzle rod cpl. NC12/16 T1 T2 NC21	Düsenstange Kpl. NC12/16 T1 T2 NC21	Линия сопла NC12/16 T1 T2 NNC21	13 017 374 13 017 375 13 017 464 13 017 465
18.1	Défecteur NC12/16 Ø78/20-6FD NC21 Ø90/20-6FD	Deflettore NC12/16 Ø78/20-6FD NC21 Ø90/20-6FD	Deflector NC12/16 Ø78/20-6FD NC21 Ø90/20-6FD	Turbulator NC12/16 Ø78/20-6F NC21 Ø90/20-6FD	Turbulator NC12/16 Ø78/20-6FD NC21 Ø90/20-6FD	Турбулятор NC12/16 Ø78/20-6FD NC21 Ø90/20-6FD	13 015 748 13 015 751
18.2	Anneau de butée			Setting keeper ring	Einstellungsring		13 018 403

Pos. Поз.	Désignation Поз.	Denominazione	Designación	Description	Bezeichnung	Название	Art. Nr. Арт.№
18.3	Electrode allu. NC12/16 NC21	Elettrodo di accensione NC12/16 NC21	Electrodo de encendido NC12/16 NC21	Ignition electrode NC12/16 NC21	Blockelektrode NC12/16 NC21	Розжиговый электрод NC12/16 NC21	13 015 848 13 015 847
18.4	Câble allumage L625 T1/T2	Cavi d'accensione L625 T1/T2	Cables de encendido L625 T1/T2	Ignition lead L625 T1/T2	Zündkabel L625 T1/T2	Розжиговый кабель L625 T1/T2	13 018 090
18.5	Ligne gicleur L426 L546 T1 T2	Linea porta ugello L426 L546 T1 T2	Línea pulverizador L426 L546 T1 T2	Nozzle assembly L426 L546 T1 T2	Düsengestänge L426 L546 T1 T2	Трубка сопла L426 L546 T1 T2	13 017 365 13 017 366
18.6	Réglette graduée	marchio	placa	ruler	Einstellskala	Шкала	13 017 802
18.7	Plaquette tableau de bord	Piastrina cruscotto	Placa del tablero de instrumentos	Dashboard plate	Deckplatte	Покрытие	13 016 951
18.8	Passer fil Ø5/9	Passa cavi Ø5/9	Capuchón de goma Ø5/9	Funnel Ø5/9	Kabeldurchführung Ø5/9	Прокладной изолятор кабеля Ø5/9	13 018 139
19	Turbine NC12 Ø146X42 NC16/21 Ø160X52	Ventilatore NC12 Ø146X42 NC16/21 Ø160X52	Turbina NC12 Ø146X42 NC16/21 Ø160X52	Air fan NC12 Ø146X42 NC16/21 Ø160X52	Ventilatorrad NC12 Ø146X42 NC16/21 Ø160X52	Колесо вентилятора NC12 Ø146 x 52 NC16/21 Ø160 x 52	13 016 689 13 016 706
20	Transformateur allu. EBI-M 2x7,5kV	Trasformatore d'accens. EBI-M 2x7,5kV	Transformador EBI-M 2x7,5kV	Ignition transfo. EBI-M 2x7,5kV	Zündtrafo EBI-M 2x7,5kV	Трансформатор розжига EBI-M 2x7,5kV	13 016 671
21	Moteur + condensateur NC12 NC16/21	Motore + condensatore NC12 NC16/21	Motor + condensador NC12 NC16/21	Motor + Capacitor NC12 NC16/21	Motor + Kondensator NC12 NC16/21	Двигатель+конденсатор NC12 NC16/21	13 016 369 13 016 368
21.1	Condensateur NC12/16 5µF, 400V NC21 6µF, 400V	Condensatore NC12/16 5µF, 400V NC21 6µF, 400V	Condensador NC12/16 5µF, 400V NC21 6µF, 400V	Capacitor NC12/16 5µF, 400V NC21 6µF, 400V	Kondensator NC12/16 5µF, 400V NC21 6µF, 400V	Конденсатор NC12/16 5µF, 400V NC21 6µF, 400V	13 015 722 13 015 723
22	Accouplement pompe/moteur	Accoppiamento pompa/servomotore	Acoplamiento bomba/motor	Coupling pump/motor	Kupplung Pumpe/Motor	Сцепление насос / двигатель	13 015 526
23	Tube Pompe / ligne gicleur	Tubeo pompe/ l.p.u.	Tubo bomba/ linea pulveriz.	Fuel-oil feed tube	Düsenzuleitung	Трубка подачи топлива к соплу	13 017 379
24	Pompe AT2 45D	Pompa AT2 45D	Bomba AT2 45D	Pump AT2 45D	Pumpe AT2 45D	Насос AT2 45D	13 018 416
24.1	Filtre H20 + joint	Filtro + guarnizione	Filtro + junta	Filter inlet	Filtereinsatz + Dichtung-Set	Фильтр + уплотнение в комплекте	13 016 253
24.2	Joint	guarnizione	junta	inlet	Dichtung	Уплотнение	13 016 205
24.3	Bobines	Bobina NC	Bobina	Magnet coil	Magnetspule	Магнитная катушка NC	13 016 001
25	Capot orange	Coperchio arancio	Tapa naranja	Orange cover	Schützhaube	Колпак оранжевый	13 018 036
26	Flexible	Tubi flessibili	Latiguillos flexibles	Fuel-oil hose	Oilschlauch	Жидкотопливный шланг	13 015 503
27	Plaquette frontale NC12 NC16 NC21	Marchio frontale NC12 NC16 NC21	Placa frontal NC12 NC16 NC21	Standard front cover NC12 NC16 NC21	Beschriftungsplatte NC12 NC16 NC21	Маркировочная табличка NC12 NC16 NC21	13 017 381 13 017 382 13 017 383
28	Bouton de réarmement	Pulsante di riarmo	Torta/ cajetín de control	Reset button	Taster / Entriegelung	Деблокирующая кнопка	13 017 380
29	Vis M5x20 / capot	Vite M5x20 / Coperchio	Tornillo M5x20 / Tapa	Screw M5x20 / cover	Schraube M5x20 / Haube		13 018 842









**Schémas électrique et hydraulique**  
**Schemi elettrico e idraulico**  
**Esquema eléctrico y hidráulico**  
**Electric and hydraulic diagrams**  
**Elektro- und Hydraulikschema**  
**Электрические и гидравлические схемы**

**NC12, NC16, NC21 H101 .....13 017 752**  
**NC12, NC16, NC21 H201 .....13 014 840**



NC12 H101 2,25 G	T1	13 017 164
NC12 H101 2,25 G	T2	13 017 165
NC16 H101 2,75 G	T1	13 017 168
NC16 H101 2,75 G	T2	13 017 169
NC21 H101 3,50 G	T1	13 015 050
NC21 H101 3,50 G	T2	13 015 051
NC12 H201 1,50 G	T1	13 017 166
NC12 H201 1,50 G	T2	13 017 167
NC16 H201 2,25 G	T1	13 017 170
NC16 H201 2,25 G	T2	13 017 171
NC21 H201 2,75 G	T1	13 015 052
NC21 H201 2,75 G	T2	13 015 053



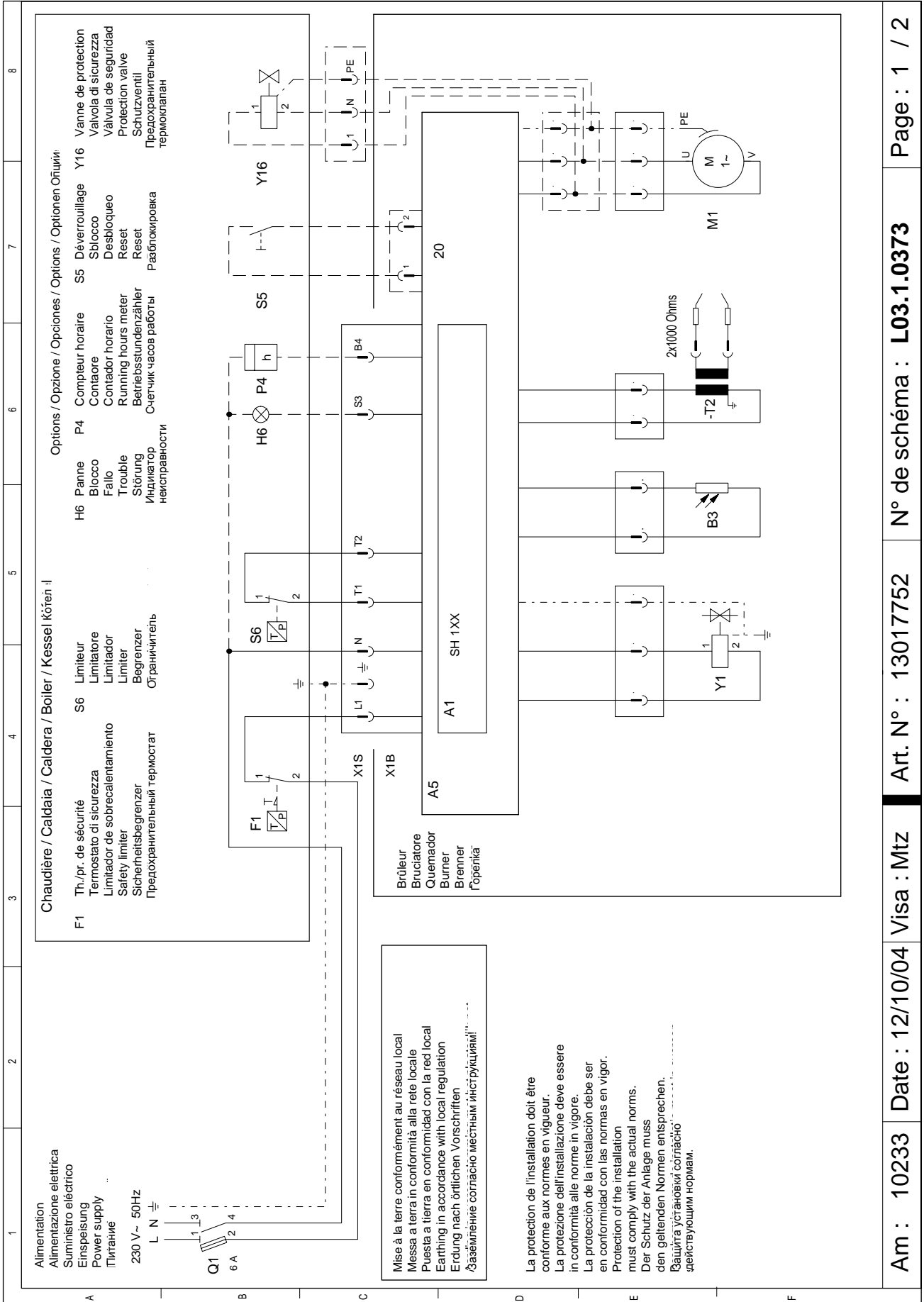

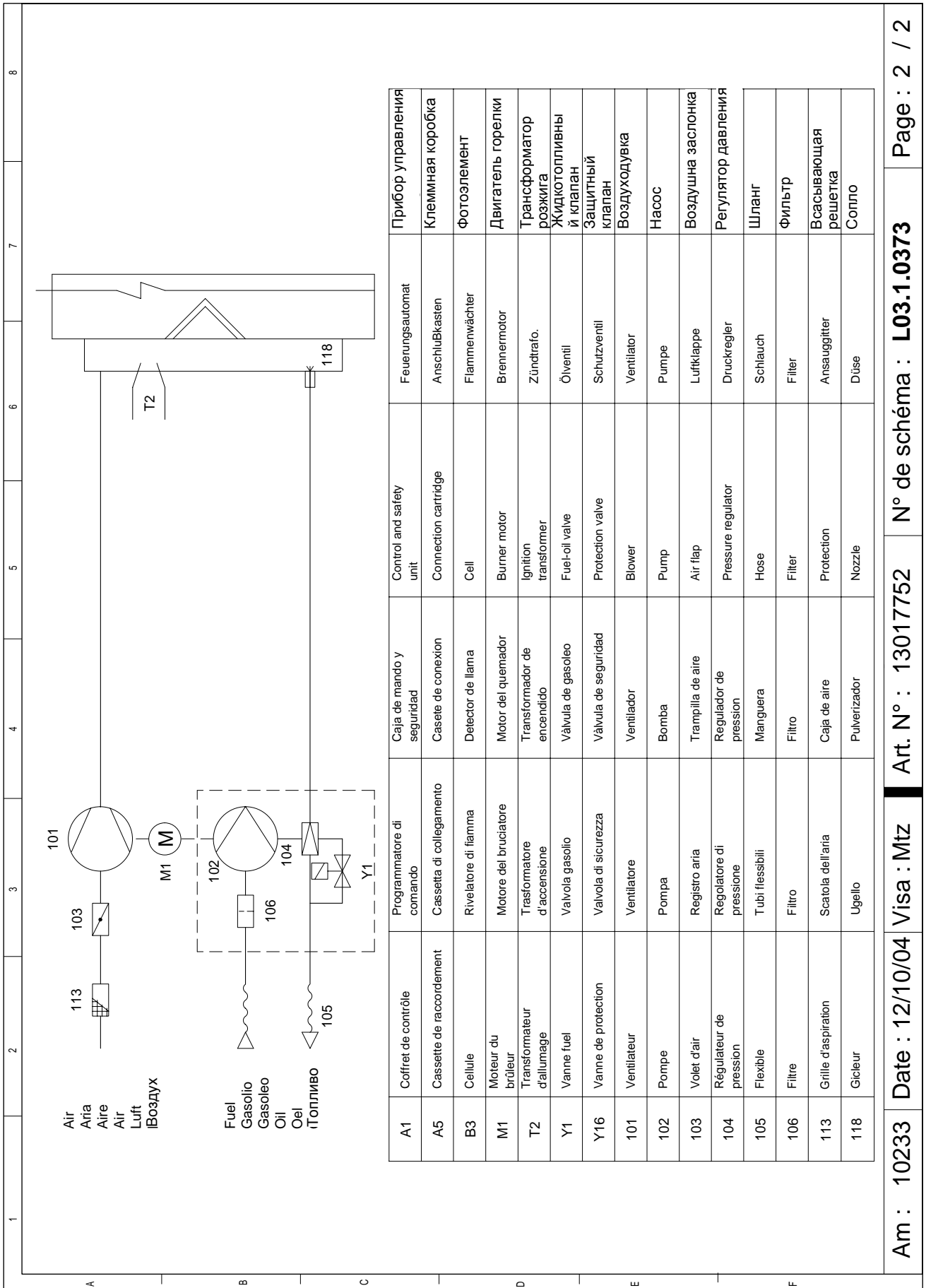

1	2	3	4	5	6	7	8
A1	Coffret de contrôle	Programmatore di comando	Caja de mando y seguridad	Control and safety unit	Feuerungsautomat	Прибор управления	
A5	Cassette de raccordement	Cassetta di collegamento	Casete de conexión	Connection cartridge	Anschlusskasten	Клеммная коробка	
B3	Cellule	Rivelatore di fiamma	Detector de llama	Cell	Flammenwächter	Фотоэлемент	
M1	Moteur du brûleur	Motore del bruciatore	Motor del quemador	Burner motor	Brennermotor	Двигатель горелки	
T2	Transformateur d'allumage	Trasformatore d'accensione	Transformador de encendido	Ignition transformer	Zündtrafo.	Трансформатор розжига	
Y1	Vanne fuel	Valvola gasolio	Valvula de gasoleo	Fuel-oil valve	Öventil	Жидкотопливный и клапан	
Y16	Vanne de protection	Valvola di sicurezza	Valvula de seguridad	Protection valve	Schutzventil	Защитный клапан	
101	Ventilateur	Ventilatore	Ventilador	Blower	Ventilator	Воздуходувка	
102	Pompe	Pompa	Bomba	Pump	Pumpe	Насос	
103	Volet d'air	Registro aria	Trampilla de aire	Air flap	Luftklappe	Воздушна заслонка	
104	Régulateur de pression	Régolatore di pressione	Regulador de pression	Pressure regulator	Druckregler	Регулятор давления	
105	Flexible	Tubi flessibili	Manguera	Hose	Schlauch	Шланг	
106	Filtre	Filtro	Filtro	Filter	Filter	Фильтр	
113	Grille d'aspiration	Scatola dell'aria	Caja de aire	Protection	Ansaugitter	Всасывающая решетка	
118	Gicleur	Ugello	Pulverizador	Nozzle	Düse	Сопло	



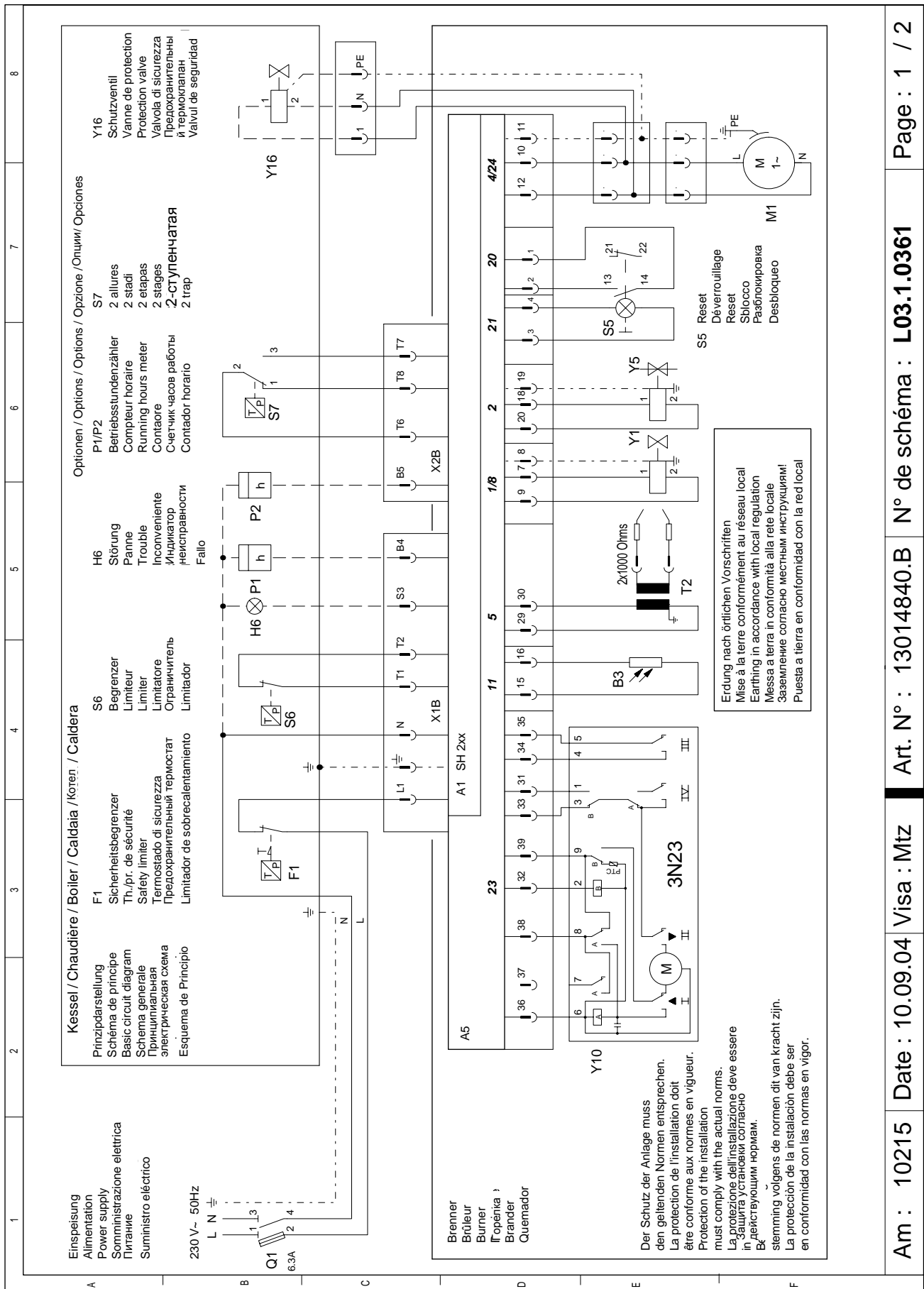

**Kessel / Chaudière / Boiler / Caldaia / Koten / Caldera**

<b>F1</b> Prinzipdarstellung Schéma de principe Basic circuit diagram Schema generale Принципальная электрическая схема Esquema de Principio	<b>S6</b> Sicherheitsbegrenzer Limiteur Limitier Limitatore Предохранительный термостат Limitador de sobrecalentamiento	<b>H6</b> Störung Panne Trouble Inconveniente Индикатор неисправности Fallo	<b>P1/P2</b> Betriebsstundenzähler Compteur horaire Running hours meter Contaore С-четчик часов работы Contaore horario	<b>S7</b> 2 allures 2 stadi 2 etapas 2 stages 2-ступенчатая 2 trap	<b>Y16</b> Schutzventil Vanne de protection Protection valve Valvola di sicurezza Предохранительный термоклапан Valvul de seguridad
--	---	---	---	--	---

**Options / Options / Options / Opzione / Опции / Opciones**

<b>F1</b> Prinzipdarstellung Schéma de principe Basic circuit diagram Schema generale Принципальная электрическая схема Esquema de Principio	<b>S6</b> Sicherheitsbegrenzer Limiteur Limitier Limitatore Предохранительный термостат Limitador de sobrecalentamiento	<b>H6</b> Störung Panne Trouble Inconveniente Индикатор неисправности Fallo	<b>P1/P2</b> Betriebsstundenzähler Compteur horaire Running hours meter Contaore С-четчик часов работы Contaore horario	<b>S7</b> 2 allures 2 stadi 2 etapas 2 stages 2-ступенчатая 2 trap	<b>Y16</b> Schutzventil Vanne de protection Protection valve Valvola di sicurezza Предохранительный термоклапан Valvul de seguridad
--	---	---	---	--	---

**Options / Options / Options / Opzione / Опции / Opciones**

<b>F1</b> Prinzipdarstellung Schéma de principe Basic circuit diagram Schema generale Принципальная электрическая схема Esquema de Principio	<b>S6</b> Sicherheitsbegrenzer Limiteur Limitier Limitatore Предохранительный термостат Limitador de sobrecalentamiento	<b>H6</b> Störung Panne Trouble Inconveniente Индикатор неисправности Fallo	<b>P1/P2</b> Betriebsstundenzähler Compteur horaire Running hours meter Contaore С-четчик часов работы Contaore horario	<b>S7</b> 2 allures 2 stadi 2 etapas 2 stages 2-ступенчатая 2 trap	<b>Y16</b> Schutzventil Vanne de protection Protection valve Valvola di sicurezza Предохранительный термоклапан Valvul de seguridad
--	---	---	---	--	---









---

**CUENOD**  
18 rue des Buchillons  
F – 74100 Annemasse