



**WATER-COOLED
WATER CHILLERS
WITH SCREW
COMPRESSORS**

WSH-2

2.200-2.230-2.260-2.280-

2.300-2.360-2.400-2.440-

3.450-3.540-3.580-3.620-3.660

**WATER-WATER
HEAT PUMPS
WITH SCREW
COMPRESSORS**

WSHH-2

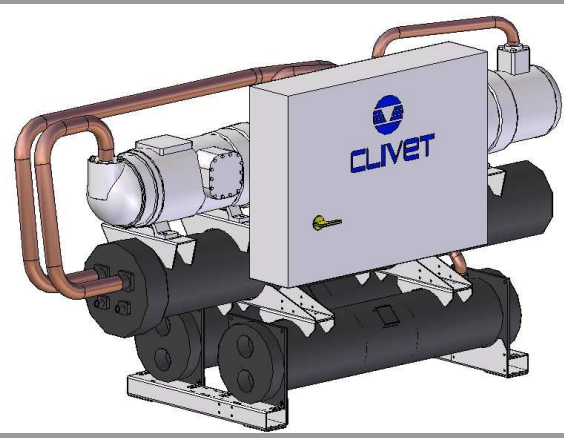

R-407C

**INSTALLATION,
OPERATION AND
MAINTENANCE MANUAL**

GENERAL

THIS MANUAL CONTAINS THE FOLLOWING SECTIONS WHICH ARE TO BE CONSIDERED AN INTEGRAL PART OF THE WHOLE AND ARE THEREFORE NOT TO BE DETACHED.

G3E0GB-3 General	R3E0GB-3 Reception/Positioning	E3E0GB-3 Electrical connections	F3E0GB-3 Start-up	C3E0GB-3 Controls
T3E0GB-3 Troubleshooting	M3E0GB-3 Maintenance	L3E0GB-3 Water connections	K3E0GB-3 Additional precautions	

GENERAL WARNINGS

This manual has been designed to enable the unit to be installed, started up and maintained correctly, making it essential to observe the following points:

- these instructions should be read carefully;
- the unit must be installed, tested and maintained by expert personal who meet the relevant legal requirements (Italian law No. 46 of 5/3/1990).
- The manufacturer declines all liability for any electrical and/or mechanical changes to the unit, which also invalid its guarantee. Any operations whatsoever that have not been expressly authorised and do not respect the information in this manual shall invalidate the guarantee.
- Observe the local safety regulations in force when installing the unit.
- Make sure the power supply conforms to the data on the unit's rating plate, located inside the door of the main electrical panel.

- This manual and the unit's wiring diagram should be carefully stored so that they are readily available to the operator when required.
- The packaging material (plastic bags, polystyrene foam, nails, etc.) is potentially dangerous and should therefore be kept away from children and recycled in compliance with the local regulations in force.
- The unit must only be used for the specific purpose it was designed, as described in the paragraph GENERAL TECHNICAL SPECIFICATIONS Any use other than that specified does not imply any commitment or constraint by the manufacturer in any way whatsoever.
- Switch off the unit in the event of faults or poor operation.
- Only have repairs carried out by a service centre authorised by the manufacturer, and insist on the use of original spare parts only.

Failure to comply with the above may compromise the safety of the unit.

The manufacturer declines all liability for any damage that may be caused whether directly or indirectly to persons or things if these instructions are not heeded.

ADDITIONAL SAFETY PRECAUTIONS

This unit has been especially designed and manufactured so to prevent any risk to persons and health hazard. For this reason, design solutions fit to eliminate (where possible) any cause of risk and sensibly reduce the probability of danger have been adopted.

Please refer to the "**Residual Risks**" section of this manual and strictly observe the behaviour prescriptions listed there in order to prevent any possible risk that hasn't been possible to avoid in the design stage.



GENERAL SPECIFICATIONS

Sizes		2.200	2.230	2.260	2.280	2.300	2.360	2.400	2.440	3.450	3.540	3.580	3.620	3.660
Cooling														
Cooling capacity (1)	kW	457	540	619	703	799	866	960	1042	1181	1281	1381	1504	1565
Compr. Input power (1)	KW	111	131	148	165	187	211	243	277	283	316	345	381	414
Heating														
Heating capacity (2)	KW	531	629	718	819	929	1021	1138	1245	1387	1518	1645	1806	1916
Compr. Input power (2)	kW	134	159	182	202	227	262	296	334	343	392	424	464	503

COMPRESSOR

Compressor type		monoscrew												
N° of compressors	Nr	2	2	2	2	2	2	2	2	3	3	3	3	3
Nominal power (C1)	HP	100	100	130	130	150	180	180	220	150	180	180	180	220
Nominal power (C2)	HP	100	130	130	150	150	180	220	220	150	180	180	220	220
Nominal power (C3)	HP	-	-	-	-	-	-	-	-	150	180	220	220	220
Capacity steps (ST)		6	6	6	6	6	6	6	6	9	9	9	9	9
Oil charge (C1)	l	7,5	7,5	10	10	10	14	14	14	10	14	14	14	14
Oil charge (C2)	l	7,5	10	10	10	10	14	14	14	10	14	14	14	14
Oil charge (C3)	l	-	-	-	-	-	-	-	-	10	14	14	14	14
Refrigerant charge (C1)	kg	38	38	40	40	45	50	50	55	45	50	50	50	55
Refrigerant charge (C2)	kg	38	40	40	45	45	50	55	55	45	50	50	55	55
Refrigerant charge (C3)	kg	-	-	-	-	-	-	-	-	45	50	55	55	55

EVAPORATOR

Evaporator type		Tube bundle												
N° of evaporators	Nr	1	1	1	1	1	1	1	1	1	1	1	1	1
Water flow rate	l/s	21,4	25,2	28,8	32,6	37,2	40,8	45,3	50,3	54,8	61,5	63,7	69,6	73,4
Pressure drops	kPa	35,9	29,4	32	40	51,6	66,8	68	71,5	83,2	72,2	78	107,1	116,4
Water content	l	124,7	221,7	206,5	206,5	184,4	222,2	252	295	295	462	462	423	423

CONDENSER

Water flow rate	l/s	27,2	32,1	36,7	41,5	47,2	51,6	57,6	63,1	70	76,4	82,6	90,2	94,7
Pressure drops	kPa	19,8	24,2	28,4	23,4	27,5	27	29,8	33,5	26,7	26,6	27,4	30,5	31,7
Water content	l	82	85,1	88,2	110,1	115,4	129,4	136,4	143,4	173,1	194,1	201,1	208,1	215,1
Evaporator type		Tube bundle												

REVERSAL ON WATER CIRCUIT (H)

Water flow	l/s	25,4	30,1	34,4	39,2	44,5	48,9	54,5	59,6	66,3	72,6	78,7	86,4	91,7
Pressure drops	kPa	32,1	26,2	28,5	36,3	46,9	60,2	61,4	64,7	59,3	50,5	51,2	72,6	81,8

CONNECTIONS

Water connections (3)		6"	8"	8"	8"	8"	8"	8"	8"	8"	8"	8"	8"	8"
Water connections (4)		4"	4"	4"	5"	5"	5"	5"	5"	5"	5"	5"	5"	5"

POWER SUPPLY

Power supply STD	V	400/3/50												
------------------	---	----------	--	--	--	--	--	--	--	--	--	--	--	--

Note:

- (1) Data referred to:
 evaporator water = 12/7°C
 condenser water = 30/35°C
- (2) Data referred to:
 evaporator water = 12/7°C
 condenser evaporator = 40/45°C
- (3) Fittings with flexible joint and solder pipe connection
 Evaporator
- (4) Threaded connections Condenser

OPERATING LIMITS (COOLING)

Sizes		2.200	2.230	2.260	2.280	2.300	2.360	2.400	2.440	3.450	3.540	3.580	3.620	3.660
Condenser														
Max inlet water temperature (1)	°C	51	48	48	50	50	51	49	49	50	51	49	49	49
Max inlet water temperature (2)	°C	53	50	50	52	52	53	51	51	52	53	51	51	51
Max inlet water temperature (3)	°C	60	60	60	60	60	60	60	60	60	60	60	60	60
Min. outlet water temperature(1)	°C	27	27	24	26	26	26	26	24	26	26	26	26	24
Evaporator														
Max inlet water temperature	°C	22	22	22	22	22	22	22	22	22	22	22	22	22
Min. outlet water temperature(4)	°C	6	6	6	6	6	6	6	6	6	6	6	6	6
Min.outlet water temperature(5)	°C	-8	-8	-8	-8	-8	-8	-8	-8	-8	-8	-8	-8	-8

Limits referred to units with PED test.

- (1) Unit at full load
 (2) Capacity controlled unit (automatic capacity control)
 (3) Unit in stop
- (4) Standard version
 (5) Low temperature version

ACCESSORIES

On demand, these units can be supplied with the following optional accessories:

- power factor correction capacitors (cosφ > 0.9)
- main door lock isolator switch (compulsory to have certification CE)
- compressor overload circuit breakers
- external exchanger pressure switch (well)
- electric expansion valves
- set point compensation with outside temperature probe
- set point compensation with 4-20mA or 0-10V signal
- set point compensation according to the outside enthalpy
- double set point with units in "Brine" version
- data logger
- remote microprocessor control unit
- rubber antivibration mounts
- serial converter kit CAN/MODBUS

CONFIGURATION CODES

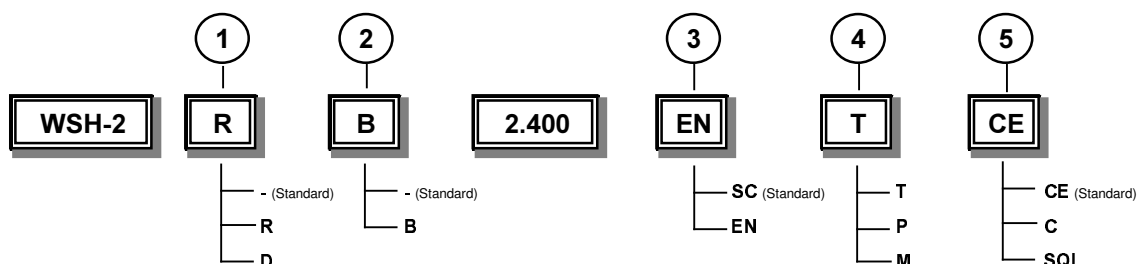

(1) ENERGY RECOVERY

Not required (-)

Partial recovery (D)

it is achieved using tube bundle exchangers, suitable for recovering the heat from the desuperheating zone, up to a maximum of 20% of the total heat of the unit.

Total Recovery (R)

it is achieved using tube bundle exchangers, suitable for recovering the heat from the desuperheating zone, up to a maximum of 100% of the total heat of the unit.

(2) LOW TEMPERATURE

Not required (-)

standard

Water low temperature (B)

range of application of this version is between +5°C down to -8°C using glycol solution. Available version:

- Brine chiller
- Double set-point function The availability of reduction capacity steps by means of solenoid valve for the compressor depends on the application temperature range. Please call our commercial dept. for details.

(3) ACOUSTIC CONFIGURATION

Standard (ST)

See description "STANDARD UNIT SPECIFICATIONS"

Extremely low noise (EN)

this configuration is obtained by inserting the compressors in a soundproofed chamber.

(4) APPLICATION

- Well water (P)
- Seawater (M)
- Tower water (T)

(5) EXCHANGER LICENSE

- CE = PED (European testing)
- C = CLIVET (Internal testing)
- SQL

EXCHANGER OPERATION LIMITS: ST (STANDARD) - EN

	EVAPORATOR			CONDENSER	
	DPr (S)	DPr (B)	DPw	DPr	DPw
	kPa	kPa	kPa	kPa	kPa
CLIVET (C)	2500 (2000)	2100 (2000)	1000	3000	1000
PED (CE)	2900 (2000)	2100 (2000)	1600	3000	1000
SQL	2450 (2000)	2100 (2000)	1000	2450	1000

Data in brackets refer to sizes from 2.400 a 3.660

DPr = Max operation pressure cooling side

DPw = Max operation pressure water side

SETTING THE CUT-OUT DEVICES AND CONTROLS (STANDARD)

		Opens	Closes		
High pressure switch	(kPa)	2700	1940	High pressure safety valve	(kPa) 3000
Low pressure switch	(kPa)	230	360	Low pressure safety valve	(kPa) 1900
Antifreeze protection	(°C)	4	6,5	Max. compressor starts per hour	(n°) 5
				Safety discharge thermostat	(°C) 120

FOULING CORRECTION FACTORS ST-EN

m ² °C/W	EVAPORATOR		CONDENSER	
	F1	FK1	F2	FK2
0.44 x 10 ⁻⁴	1.00	1.00	1.00	1.00
0.88 x 10 ⁻⁴	0.97	0.99	0.97	1.08
1.76 x 10 ⁻⁴	0.94	0.98	0.92	1.05

F1 = Cooling capacity correction factors

FK1 = Compressor power input correction factor

F2 = Cooling capacity correction factors

FK2 = Compressor absorbed power correction factors

SOUND LEVELS

Acoustic configuration ST

Sizes	Sound power level (dB)								Sound pressure level	Sound power level
	Octave band (Hz)									
	63	125	250	500	1000	2000	4000	8000	dB(A)	dB(A)
2.200	75	71	91	87	85	89	70	66	74	92
2.230	75	70	91	85	86	90	69	64	74	93
2.260	75	69	91	83	88	90	67	60	75	93
2.280	73	69	92	87	89	89	69	63	75	94
2.300	72	70	94	90	90	89	72	66	76	95
2.360	75	72	96	85	93	91	71	63	78	96
2.400	76	71	97	86	94	91	74	65	78	97
2.440	78	70	98	87	95	91	76	66	79	98
3.450	76	74	97	94	94	93	76	70	79	99
3.540	78	74	99	88	96	94	74	66	79	99
3.580	79	74	100	89	96	94	76	67	80	100
3.620	79	73	100	89	97	93	77	68	80	100
3.660	80	73	101	90	98	93	78	69	81	100

Acoustic configuration LN

Sizes	Sound power level (dB)								Sound pressure level	Sound power level
	Octave band (Hz)									
	63	125	250	500	1000	2000	4000	8000	dB(A)	dB(A)
2.200	73	68	89	79	75	83	61	57	67	86
2.230	73	68	89	77	77	83	60	55	68	87
2.260	73	67	89	75	78	84	58	51	68	87
2.280	72	68	91	80	80	84	61	55	69	88
2.300	70	68	92	82	81	83	63	57	69	88
2.360	73	70	96	78	84	86	63	55	72	91
2.400	75	69	97	79	85	85	66	57	73	92
2.440	76	69	97	80	86	85	67	58	73	92
3.450	74	73	96	87	86	87	68	62	73	93
3.540	76	73	98	81	87	88	66	58	74	94
3.580	77	72	99	82	88	88	68	59	74	94
3.620	78	72	100	82	89	88	69	60	75	95
3.660	79	71	100	83	89	88	70	61	75	95

The sound levels refer to units operating at full load, with rated test conditions.

The sound pressure level is measured 1 m from the surface of the unit operating in an open field.

Data referred to:

evaporator water = 12/7 °C

condenser water = 30/35 °C

DIMENSIONS Size 2.200

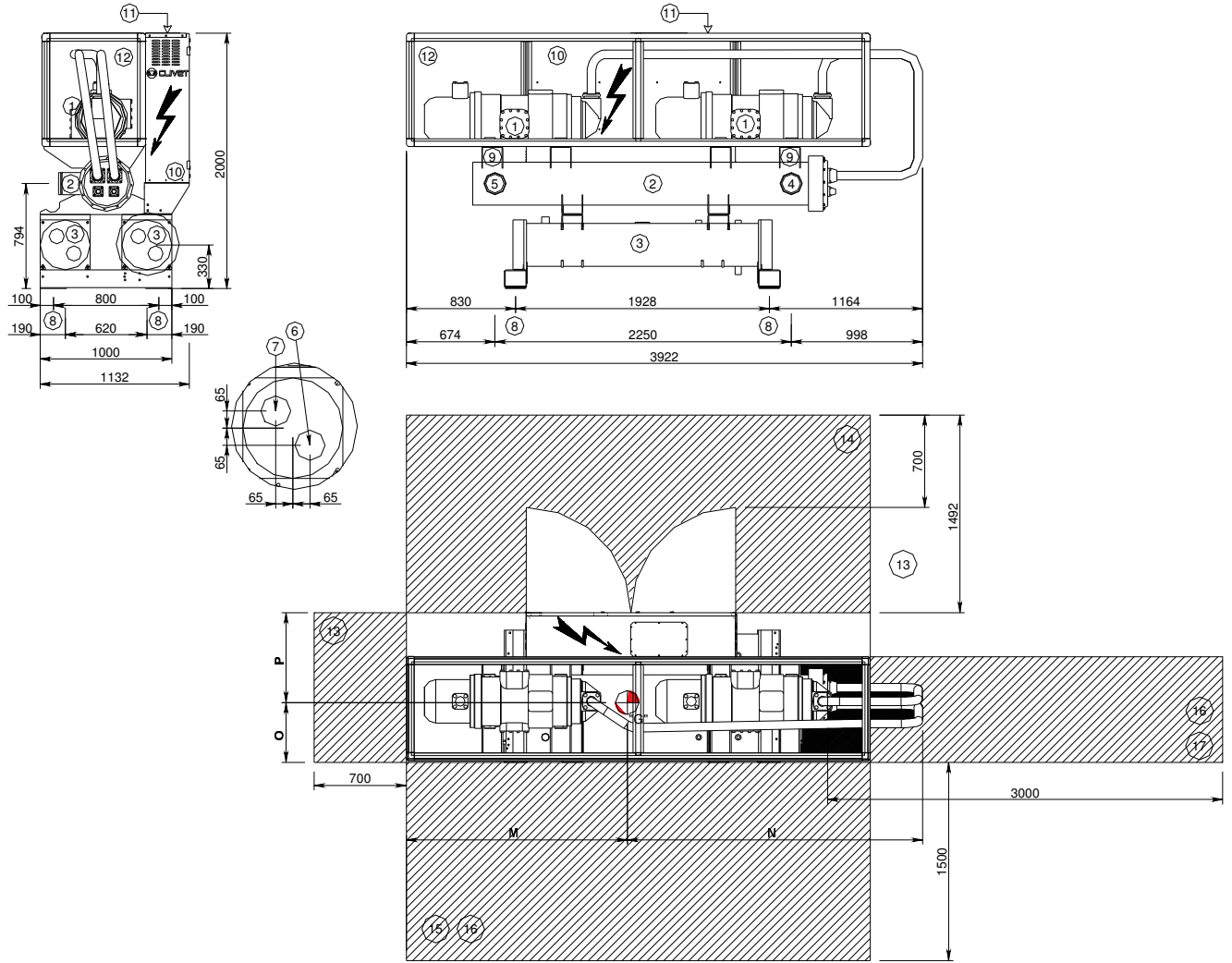

Size	2.200	
	ST	LN
N	1985	1995
M	1937	1927
P	613	622
O	522	513

Note: Dimensions are in mm.

Key:

- (1) COMPRESSOR
- (2) EVAPORATOR
- (3) CONDENSER
- (4) EVAPORATOR INLET WATER
- (5) EVAPORATOR OUTLET WATER
- (6) CONDENSER INLET WATER
- (7) CONDENSER OUTLET WATER
- (8) HOLE TO HANG UNIT
- (9) LIFTING HOLES
- (10) ELECTRICAL PANEL
- (11) POWER INPUT
- (12) SOUND PROOF ENCLOSURE (ONLY IN THE EXPECTED VERSIONS)
- (13) MINIMUM DIMENSION ON THE ELECTRICAL SIDE
- (14) MINIMUM DIMENSION FOR A SAFE PASSAGE
- (15) MINIMUM DIMENSION FOR MAINTENANCE
- (16) MINIMUM DIMENSION FOR WATER CONNECTIONS

Sizes 2.230-2.260

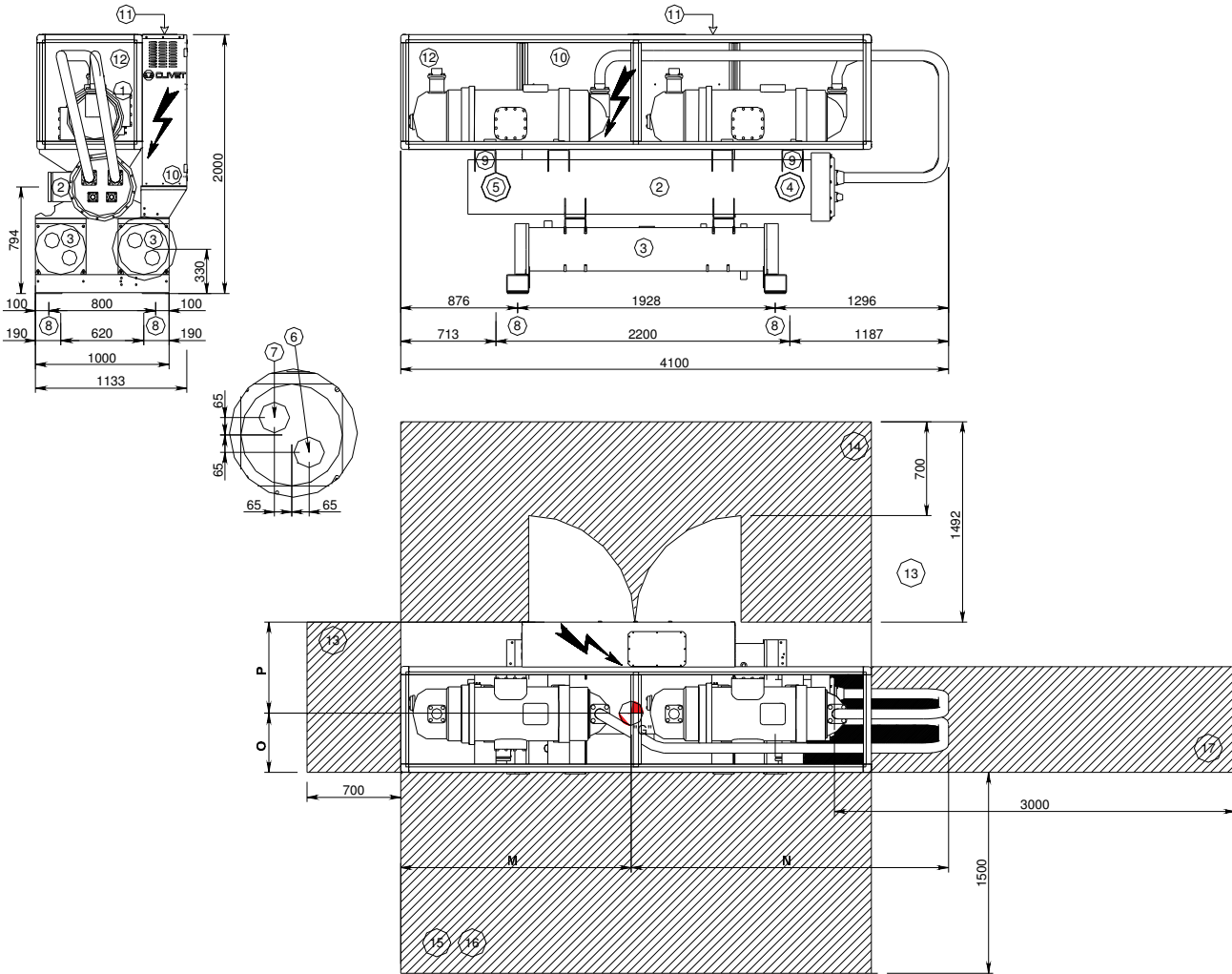

Size	2.230		2.260	
	ST	LN	ST	LN
N	1924	1935	1879	1892
M	1992	1980	2037	2024
P	620	627	625	632
O	515	507	510	503

Note: Dimensions are in mm.

Key:

- (1) COMPRESSOR
- (2) EVAPORATOR
- (3) CONDENSER
- (4) EVAPORATOR INLET WATER
- (5) EVAPORATOR OUTLET WATER
- (6) CONDENSER WATER INLET
- (7) CONDENSER WATER OUTLET
- (8) HOLE TO HANG UNIT
- (9) LIFTING HOLES
- (10) ELECTRICAL PANEL
- (11) POWER INPUT
- (12) SOUND PROOF ENCLOSURE (ONLY IN THE EXPECTED VERSIONS)
- (13) MINIMUM DIMENSION ON THE ELECTRICAL SIDE
- (14) MINIMUM DIMENSION FOR A SAFE PASSAGE
- (15) MINIMUM DIMENSION FOR MAINTENANCE
- (16) MINIMUM DIMENSION FOR WATER CONNECTIONS

Sizes 2.280-2.300

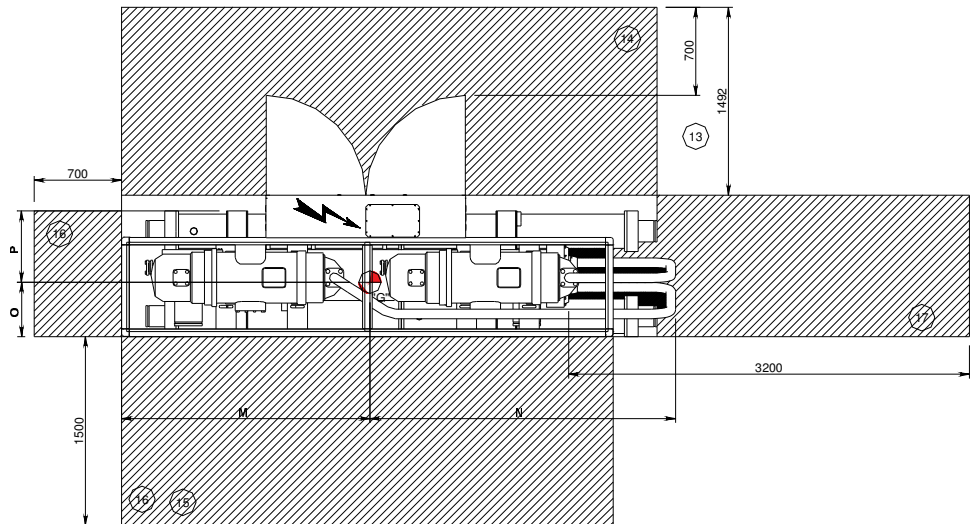
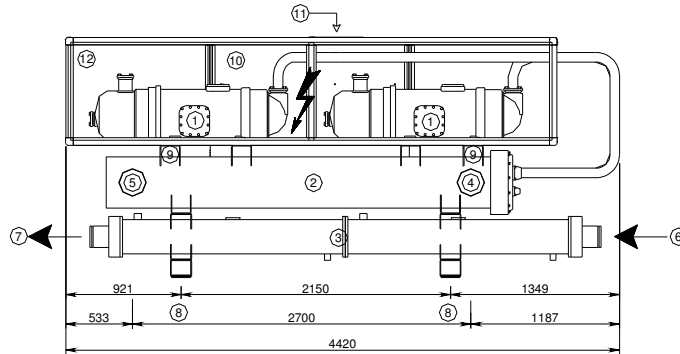
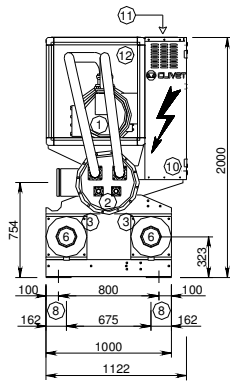

Size	2.280		2.300	
	ST	LN	ST	LN
N	2380	2377	2388	2388
M	1850	2043	1839	2032
P	626	626	604	622
O	496	496	518	500

Note: Dimensions are in mm.

Key:

- (1) COMPRESSOR
- (2) EVAPORATOR
- (3) CONDENSER
- (4) EVAPORATOR WATER INLET
- (5) EVAPORATOR WATER OUTLET
- (6) CONDENSER WATER INLET
- (7) CONDENSER WATER OUTLET
- (8) HOLE TO HANG UNIT
- (9) LIFTING HOLES
- (10) ELECTRICAL PANEL
- (11) POWER INPUT
- (12) SOUND PROOF ENCLOSURE (ONLY IN THE EXPECTED VERSIONS)
- (13) MINIMUM DIMENSION ON THE ELECTRICAL SIDE
- (14) MINIMUM DIMENSION FOR A SAFE PASSAGE
- (15) MINIMUM DIMENSION FOR MAINTENANCE
- (16) MINIMUM DIMENSION FOR WATER CONNECTIONS

Size 2.360

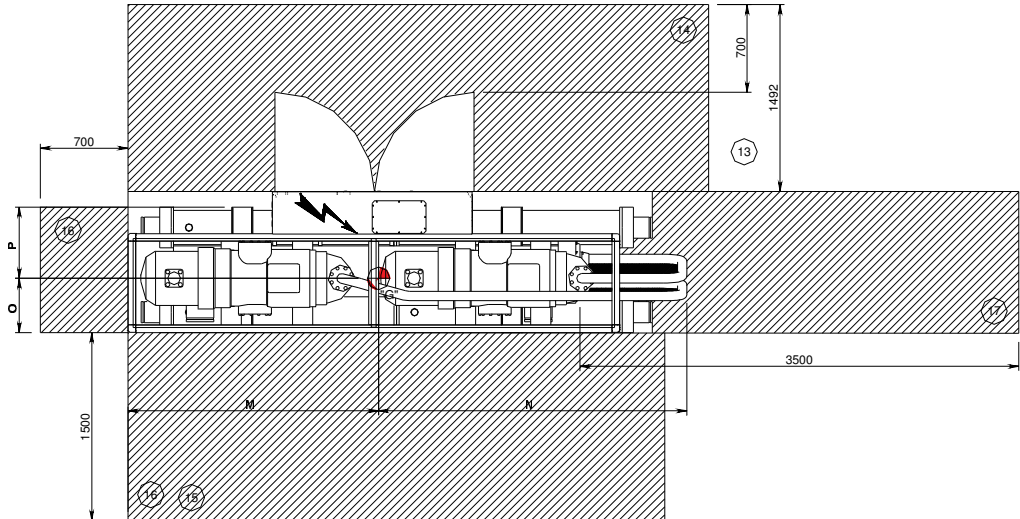
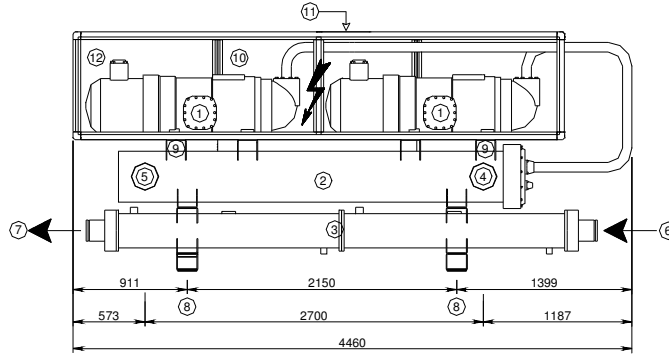
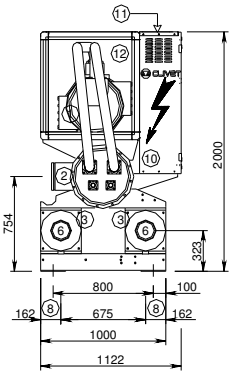

Size	2.360	
	ST	LN
N	2069	2067
M	2288	2393
P	632	638
O	490	484

Note: Dimensions are in mm.

Key:

- (1) COMPRESSOR
- (2) EVAPORATOR
- (3) CONDENSER
- (4) EVAPORATOR WATER INLET
- (5) EVAPORATOR WATER OUTLET
- (6) CONDENSER WATER INLET
- (7) CONDENSER WATER OUTLET
- (8) HOLE TO HANG UNIT
- (9) LIFTING HOLES
- (10) ELECTRICAL PANEL
- (11) POWER INPUT
- (12) SOUND PROOF ENCLOSURE (ONLY IN THE EXPECTED VERSIONS)
- (13) MINIMUM DIMENSION ON THE ELECTRICAL SIDE
- (14) MINIMUM DIMENSION FOR A SAFE PASSAGE
- (15) MINIMUM DIMENSION FOR MAINTENANCE
- (16) MINIMUM DIMENSION FOR WATER CONNECTIONS
- (17) MINIMUM DIMENSION FOR TUBE BUNDLE EXTRACTION

Sizes 2.400-2.440

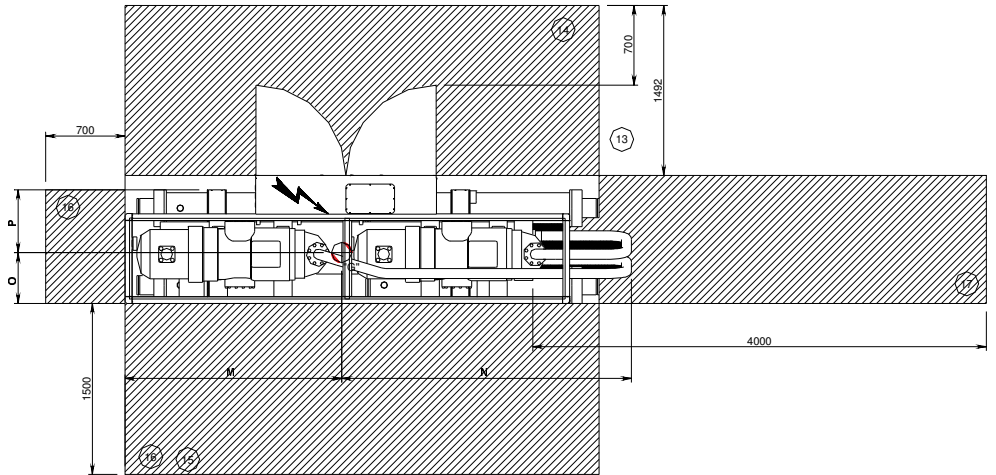
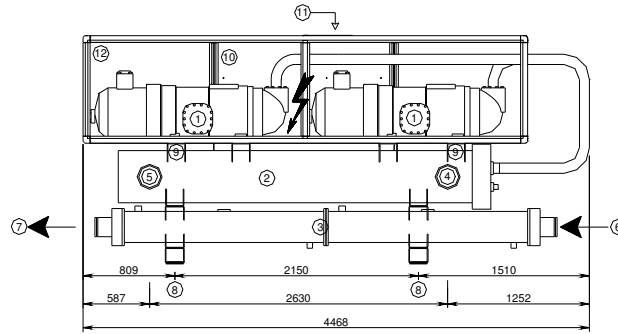
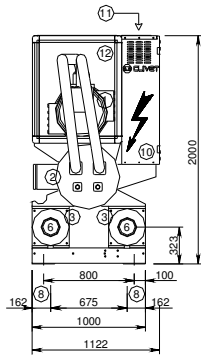

Size	2.400		2.440	
	ST	LN	ST	LN
N	2217	2217	2479	2480
M	2148	2251	1886	1988
P	614	614	634	639
O	508	508	488	483

Note: Dimensions are in mm.

Key:

- (1) COMPRESSOR
- (2) EVAPORATOR
- (3) CONDENSER
- (4) EVAPORATOR WATER INLET
- (5) EVAPORATOR WATER OUTLET
- (6) CONDENSER WATER INLET
- (7) CONDENSER WATER OUTLET
- (8) HOLES TO HANG UNIT
- (9) LIFTING HOLES
- (10) ELECTRICAL PANEL
- (11) POWER INPUT
- (12) SOUND PROOF ENCLOSURE (ONLY IN THE EXPECTED VERSIONS)
- (13) MINIMUM DIMENSION ON THE ELECTRICAL SIDE
- (14) MINIMUM DIMENSION FOR A SAFE PASSAGE
- (15) MINIMUM DIMENSION FOR MAINTENANCE
- (16) MINIMUM DIMENSION FOR WATER CONNECTIONS

Size 3.450

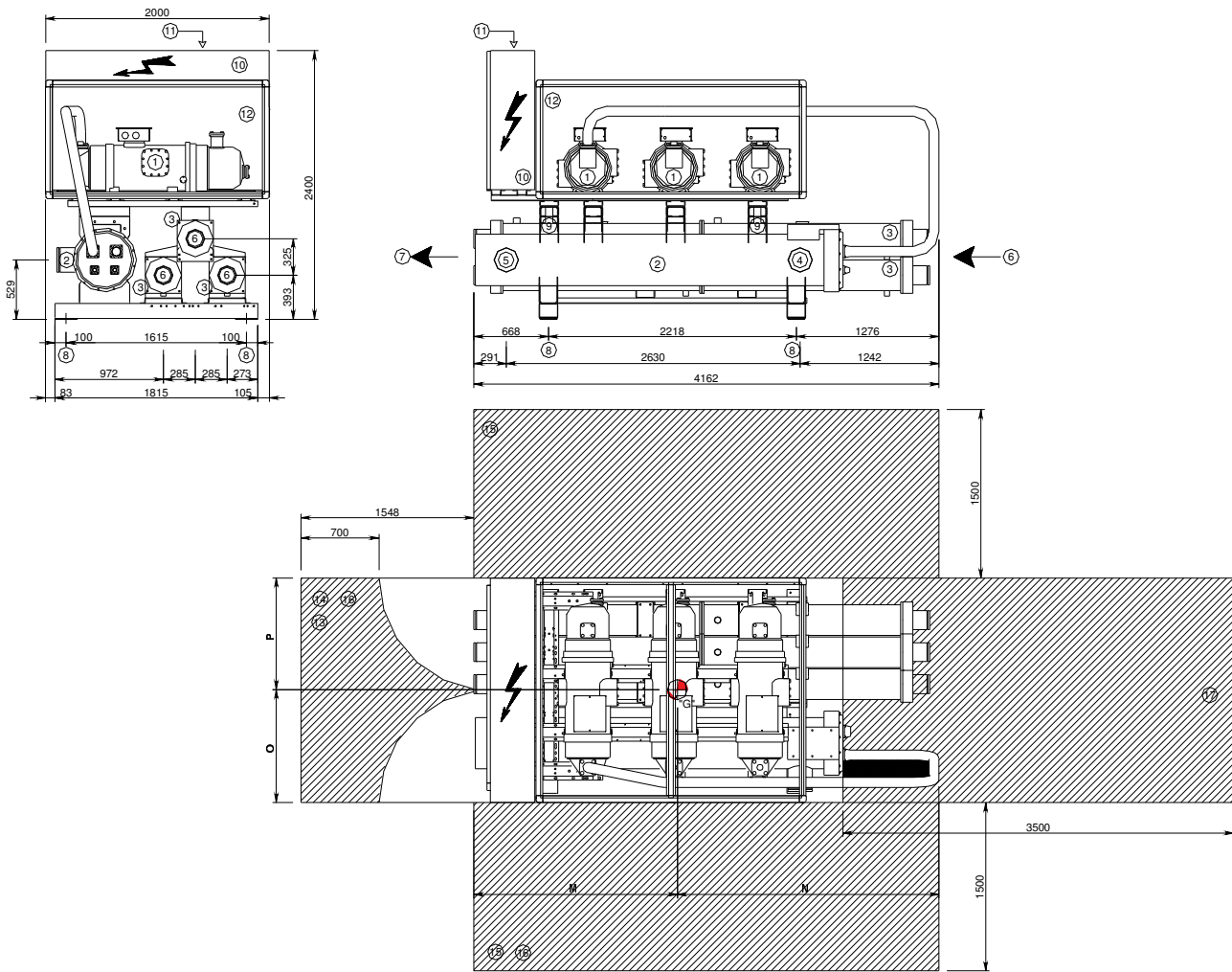

Size	3.450	
	ST	LN
N	2167	2203
M	1995	1959
P	1009	1007
O	991	993

Note: Dimensions are in mm.

Key:

- (1) COMPRESSOR
- (2) EVAPORATOR
- (3) CONDENSER
- (4) EVAPORATOR WATER INLET
- (5) EVAPORATOR WATER OUTLET
- (6) CONDENSER WATER INLET
- (7) CONDENSER WATER OUTLET
- (8) HOLES TO HANG UNIT
- (9) LIFTING HOLES
- (10) ELECTRICAL PANEL
- (11) POWER INPUT
- (12) SOUND PROOF ENCLOSURE (ONLY IN THE EXPECTED VERSIONS)
- (13) MINIMUM DIMENSION ON THE ELECTRICAL SIDE
- (14) MINIMUM DIMENSION FOR A SAFE PASSAGE
- (15) MINIMUM DIMENSION FOR MAINTENANCE
- (16) MINIMUM DIMENSION FOR WATER CONNECTIONS
- (17) ONLY ACOUSTIC CONFIGURATION EN

Sizes 3.540-3.580-3.620-3.660

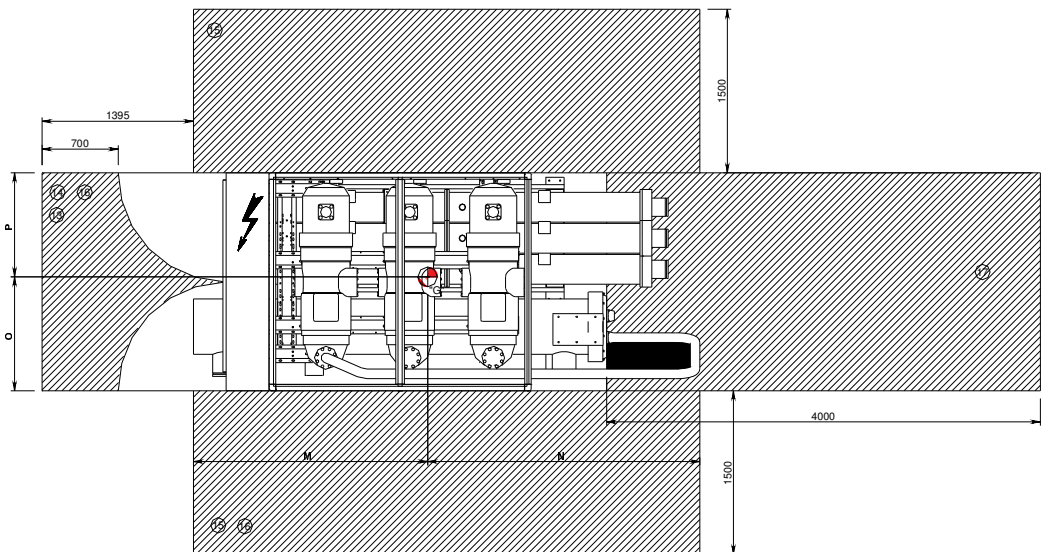
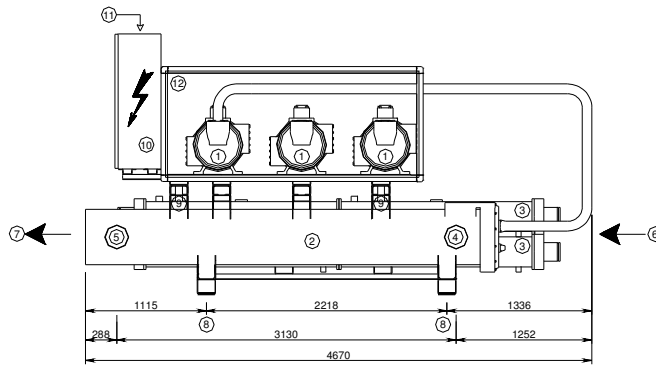
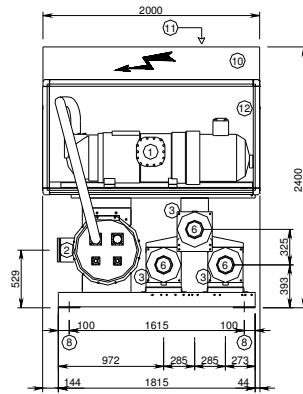

Sizes	3.540		3.580		3.620		3.660	
	ST	LN	ST	LN	ST	LN	ST	LN
N	2366	2375	2371	2380	2364	2373	2362	2371
M	2304	2295	2299	2290	2306	2297	2308	2299
P	967	967	965	965	968	969	968	968
O	1033	1033	1035	1035	1032	1031	1032	1032

Note: Dimensions are in mm.

Key:

- (1) COMPRESSOR
- (2) EVAPORATOR
- (3) CONDENSER
- (4) EVAPORATOR WATER INLET
- (5) EVAPORATOR WATER OUTLET
- (6) CONDENSER WATER INLET
- (7) CONDENSER WATER OUTLET
- (8) HOLES TO HANG UNIT
- (9) LIFTING HOLES
- (10) ELECTRICAL PANEL
- (11) POWER INPUT
- (12) SOUND PROOF ENCLOSURE (ONLY IN THE EXPECTED VERSIONS)
- (13) MINIMUM DIMENSION ON THE ELECTRICAL SIDE
- (14) MINIMUM DIMENSION FOR A SAFE PASSAGE
- (15) MINIMUM DIMENSION FOR MAINTENANCE
- (16) MINIMUM DIMENSION FOR WATER CONNECTIONS
- (17) ONLY ACOUSTIC CONFIGURATION EN