



**WATER-COOLED
WATER CHILLERS
WITH SCREW
COMPRESSORS**

WSH-2

2.200-2.230-2.260-2.280-

2.300-2.360-2.400-2.440-

**WATER-WATER
HEAT PUMPS
WITH SCREW
COMPRESSORS**

WSHH-2

3.450-3.540-3.580-3.620-3.660

RESIDUAL RISKS

CONTENTS:

**DEFINITION OF DANGEROUS AREA
GENERAL RISKS
REFRIGERANT SAFETY DIAGRAMS**

WARNING

THIS SPECIFIC SECTION OF THE MANUAL POINTS OUT EACH OPERATION WHICH BRINGS WITH IT A POSSIBLE RISKY SITUATION AS WELL AS ALL THE PARTICULAR PRECAUTIONS TO OBSERVE

DEFINITION OF DANGEROUS AREA

The figure below points out the area that is accessible to authorised personnel only.

- The external dangerous zone is a precise area all around the unit and its vertical projection on the ground in the case of hanging unit.
- The internal dangerous zone is the area that one can enter only with previous and intentional removal of the protecting panels.

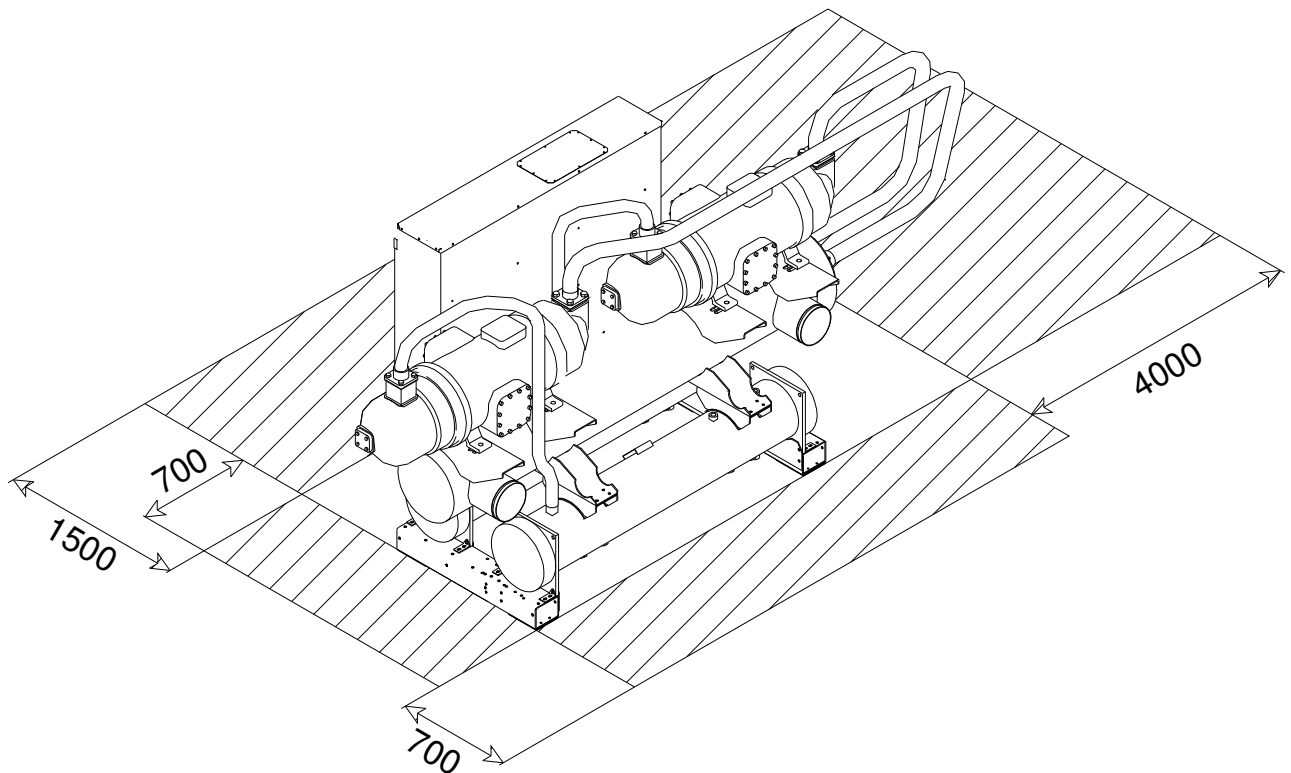

Note: dimensions in mm.

GENERAL RISKS

Particular area	Residual risks	Modality	Instructions
Compressors	Burns	Contact	Avoid incidental contacts. Wear protective gloves. Install compressor opening protective grills (optional).
Outlet pipe	Burns	Contact	Avoid incidental contacts. Wear protective gloves. Install compressor opening protective grills (optional).
LP safety valve	Wounds Intoxication	Refrigerant gas exhaust due to the intervention of the safety cut-out.	Avoid entering the dangerous zone. Install compressor opening protective grills (optional). Pipe in an appropriate way the safety exhaust valves. Wear appropriate clothes and gloves.
Area surrounding the unit	Wounds Intoxication Serious burns Death	Explosion due to a rise in ambient temperature (fire).	Never shut the compressor inlet/outlet valves when the unit is off.
Area surrounding the unit	Death by: Serious burns Intoxication	Fire due to short-circuit or overheating of the power supply cables before the unit mains switch.	Exact measurement of cables and safety cut-outs of the connections to the power supply line.
Unit internal part	Death by: Serious burns Intoxication	Defective insulation of the power supply cables before the unit mains switch.	Enter the unit only after having opened the mains isolator switch on the power supply line (customer's care).
Inner dangerous area	Death by: Electrocution	Metal parts under tension.	Put scrupulously to earth the metal parts of the unit.
Inner dangerous area	Death by: Electrocution Serious burns	Contact with parts under tension which one can reach only after having removed the protective panels.	Open the unit mains switch and lock it with a padlock before removing the panels.

REFRIGERANT SAFETY DIAGRAMS

01	Identifying elements for the substance	Product name: forane 407C N°SDS 01965/1 Supplier: ELF ATOCHEM ITALIA Via G.Murat 17, 20159 Milano tel. 02/668111
02	Information concerning composition of components	Chemical nature of the compound Mixture based on: <ul style="list-style-type: none"> Forane 32(difluoromethane) (N° CAS: 75-10-5) Forane 125 (pentafluoroethane) (N° CAS: 354-33-6) Forane 134a (1.1.1.2 tetrafluoroethane) (N° CAS: 811-97-2)
03	Identification of risk	Greatest physical and chemical dangers: Thermal decomposition in toxic and corrosive products
04	First-aid measures	General information: Inhalation: Carry the victim into the open air. Resort to oxygen or artificial respiration if necessary. Contact with skin: Frostbite must be treated in the same way as burns. Contact with the eyes: Immediate rinsing in abundant water. If irritation should continue, consult an ophthalmologist. Medical instructions: Do not administer catecholamines (due to the cardiac sensitisation caused by the product)

05	Fire prevention measures	<p>Specific dangers: Thermal decomposition into toxic and corrosive products. Hydrofluoric acid. Carbon monoxides.</p> <p>Specific means of intervention: Cool containers/cisterns with jets of water. Prevent any sparks or flames. Do NOT smoke.</p> <p>Special protection systems for fire-fighting squads: Carry breathing apparatus and wear protective clothing.</p>
06	Measures to take in case of accidental spillage	<p>Individual precautions: Avoid contact with the skin, eyes and inhalation of vapours. Use personal protection devices.</p> <p>In an enclosed space: ventilate or use breathing apparatus (risk of suffocation). NO SMOKING ALLOWED</p> <p>Precautions for environmental protection: Minimise the amount of waste deposited in the environment.</p>
07	Manipulation and storage	<p>Technical measures/precautions. Form of storage and manipulation applicable to the products: PRESSURIZED GAS. Ensure adequate ventilation and evacuation for the level of equipment.</p> <p>Advice for use: Prevent sparks and contact with hot surfaces. DO NOT SMOKE.</p> <p>Technical measures/Storage procedures: Store at room temperature in the original container. Keep away from flames, hot surfaces and sparks. Store in a cool, well-ventilated place. Protect full containers from sources of heat to avoid excessive pressures.</p> <p>Recommended: Ordinary steel.</p> <p>Avoid: Alloy containing more than 2% magnesium. Plastics.</p>
08	Control of individual exposure/protection	<p>Precautionary measures to be taken: Ensure a sufficient exchange of air and/or suction in workplaces.</p> <p>Control parameters. Exposure limits: There is no F-USA limit value Forane 134a Elf recommended limit value: VME=1000ppm Forane 32 Elf recommended limit value: VME=1000ppm Forane 125 Elf recommended limit value: VME=1000ppm Respiratory protection: In case of insufficient ventilation, carry suitable breathing apparatus. Protection for the hands: Gloves Protection for the eyes: Protective eyewear.</p>
09	Physical and chemical properties	<p>Physical state (20°C): liquid gas Colour: colourless Smell: Slightly similar to ether; pH: not applicable. Boiling point/interval: -42,4 °C Melting point/interval: Not inflammable in test conditions Vapour pressure: (25°C): 1.13 Mpa (11,3 bar) a (50°C): 2.11 Mpa (21,1 bar) a (70°C): 3.26 Mpa (32,6 bar) Vapour density: At boiling point 4,54 kg/m³ Density: (25°C) 1133 kg/m³ a (50°C) 1004 kg/m³ a (70°C) 861 kg/m³</p>
10	Stability and reactivity	<p>Conditions to avoid: Avoid contact with flames and red-hot metal surfaces.</p> <p>Dangerous decomposition products: Thermal decomposition into toxic and corrosive products: Toxic fluorinates Hydrogen fluoride (hydrofluoric acid)</p> <p>Further information: Product stable in normal storage and handling conditions</p>
11	Toxicological information	<p>Inhalation: Practically non-toxic in experiments conducted on animals Forane 134a, 32, 125. No rat mortality at 500000 ppm/4h. As with other volatile aliphatic halogenated compounds, with the accumulation of vapours and/or the inhalation of large quantities, the product can cause: loss of consciousness and heart problems aggravated by stress and lack of oxygen; risk of death.</p> <p>Contact with skin: Frostbite possible from splashes of liquefied gas.</p> <p>Chronic toxicity: Studies on extended inhalation in animals have not highlighted any sub-chronic toxic effect (rat/3 months/ Inhalation:50000ppm)</p> <p>Specific effects: Genotoxicity, according to experimental data available Forane 134a, 32, 125 NOT Genotoxic</p> <p>Carcinogenic effect: Forane 134a experiments on animals have not demonstrated a clear cancerogenous effect (rat /oral inhalation)</p> <p>Toxicity for reproduction: Foetal development Forane 134a, 32, 125 according to available data there are no toxic effects for foetal development. Fertility, according to available data for animals: Forane 134a no effect on fertility (mice/inhalation)</p>

12	Ecological information	<p>Forane 32 Durability/degradability: Not easily biodegradable in water: 5% after 28d Bioaccumulation: Practically non-absorbable by biological organisms log pow 0,21 Forane 125 Mobility: Rapid evaporation t ½ life 3,2 h (estimated) Durability/degradability: Not easily biodegradable in water: 5% after 28 days. In the atmosphere degradation at rate of 1/2 life in 28,3 y (estimated). . Potential for destruction of ozone ODP (R-11 = 1)=0. Potential greenhouse effect (GWP): (HGWP) = 0,58. Low absorption in ground and sediments log Koc= 1,3-1,7 Bioaccumulation: Practically non-absorbable by biological organisms log pow 1,48 Forane 134a Mobility: Rapid evaporation t ½ life 3 h (estimated) Durability/degradability: Not easily biodegradable in water: 3% after 28 days. In the atmosphere degradation at rate of 3% after 28 days (estimated). Potential for destruction of ozone ODP (R-11 = 1)=0. Potential greenhouse effect (GWP): (HGWP) = 0,26. Bioaccumulation: Practically non-absorbable by biological organisms log pow 1,06</p>
13	Notes concerning disposal	Disposal of product: recycle or incinerate.
14	Information on shipping	<p>Consult the ELF ATOCHEM safety service for supplementary information and updates ONU number 3163. RID/ADR class 2 figure (and letter) 4° a Regulations: No. danger/No. material 20/3163 label 2 IMDG class 2.2 ONU (IMDG) 3163 Regulations: 2.2 /2 label IATA class 2.2 ONU (IATA) or No.ID 3163 Regulations: 2.2 /2 label</p>
15	Information on regulation	<p>EEC directives Security reports: D.91/155/CEE modified by D.93/112/CEE: Dangerous substances Classification/CE mark Dangerous manufactured compounds: Not classified as dangerous Inventory: EINECS compliant</p>
16	Other information	<p>Recommended uses: low-temperature coolant Bibliographical references: Encyclopedie des gas (Air Liquide-ed.1976- ELSEVIER AMSTERDAM)</p>

This document refers to the product as is and which conforms to the specifications supplied by ELF ATOCHEM.

If combinations or mixtures are made, check that there are no new dangers resulting from this action. The information provided in this report has been provided in good faith and is based on our latest knowledge of the product in question as of the date of publication of the same. The attention of users is drawn to the potential risks of employing the product for any use other than that for which it is intended. This report must be used and reproduced solely for purposes of prevention and safety. The list of legislative, regulatory or administrative texts must not be considered exhaustive. The product user is under obligation to refer to all the official texts concerning the use, conservation and manipulation of the product for which he is sole responsible. The product user must also provide all those who might come into contact with the product with the information necessary for their safety at work and the protection of their health and that of the environment, giving them a copy of this safety information report.