



WATER CHILLER CONDENSERLESS
IT CAN BE COUPLED WITH REMOTE
CONDENSER CLIVET SERIES CEM

MSE-2 2.200-2.230-2.260-2.280-2.300-2.360-
2.400-2.440-3.450-3.540-3.580-3.620-3.660

RESIDUAL RISKS

CONTENTS:

DEFINITION OF DANGEROUS AREA
GENERAL RISKS
REFRIGERANT SAFETY DIAGRAM

WARNING

THIS SPECIFIC SECTION OF THE MANUAL POINTS OUT EACH OPERATION WHICH BRINGS WITH IT A POSSIBLE RISKY SITUATION AS WELL AS ALL THE PARTICULAR PRECAUTIONS TO OBSERVE.

DEFINITION OF DANGEROUS AREA

The figure below points out the area which is accessible to authorised personnel only.

The **external dangerous zone** is a precise area all around the unit and its vertical projection on the ground in the case of hanging unit.

The **internal dangerous zone** is the area which one can enter only with previous and intentional removal of the protecting panels.

Figure 1

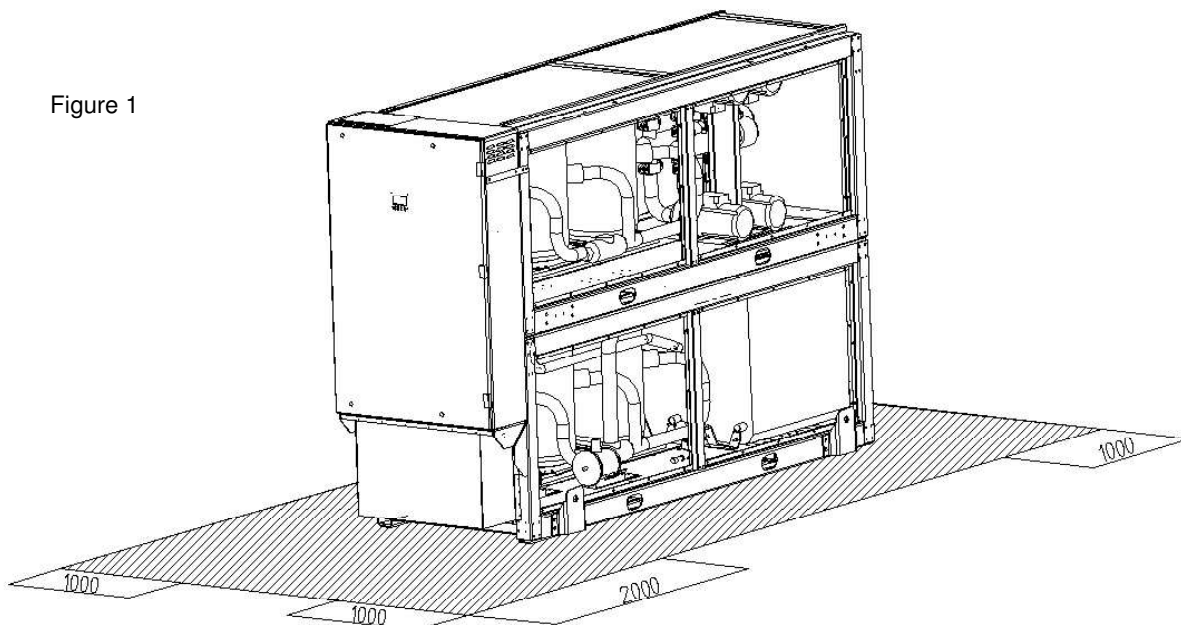

Note: dimensions expressed in mm.

RISCHI GENERICI

Particular area	Danger	Modality	Instructions
Compressors	Burns	Contact	Avoid incidental contacts Wear protective gloves Apply compressor guards (optional).
Hot gas pipe	Burns	Contact	Avoid incidental contacts Wear protective gloves Apply compressor guards (optional).
LP safety valve	Wounds Intoxication	Refrigerant gas exhaust due to the intervention of the safety cut-out.	Avoid entering the dangerous zone Apply compressor guards (optional). Pipe in an appropriate way the safety exhaust valves Wear appropriate clothes and gloves.
Area surrounding the unit	Wounds Intoxication Serious burns Death	Explosion due to a rise in ambient temperature (fire).	Never shut the compressors inlet/outlet valves when the unit is off.
Area surrounding the unit	Death by: Serious burns Intoxication	Fire due to short-circuit or overheating of the power supply cables upstream of the unit mains switch.	Exact measurement of cables and safety cut-outs of the connections to the power supply line.
Unit internal part	Death by: Electrocution Serious burns	Defective insulation of the power supply cables upstream of the unit mains switch.	Enter the unit only after having opened the mains switch which connects the unit to the power supply line (customer's care)
Internal dangerous area	Death by: Electrocution	Contact with metallic components under tension.	Put scrupulously to earth the metal parts of the unit.
Internal dangerous area	Death by: Electrocution Serious burns	Contact with parts under tension which one can reach only after having removed the protective panels	Open the unit mains switch and lock it with a padlock before removing the panels.

REFRIGERANT SAFETY DIAGRAM

01	Identifying elements for the substance	Product name: forane 407C N° SDS 01965/1 Supplier: ELF ATOCHEM ITALIA Via G.Murat 17, 20159 Milano tel. 02/668111	Product name: forane 22 N° SDS 0005/7 Supplier: ELF ATOCHEM ITALIA 4 cours Michelet Cedex 42, 92091 Paris, France. Tel: 00331 49.00.80.80
02	Information concerning composition of components	CHEMICAL NATURE OF THE COMPOUND Mixture based on: * Forane 32(difluoromethane) (N° CAS: 75-10-5) * Forane 125 (pentafluoroethan) (N° CAS: 354-33-6) * Forane 134a (1.1.1.2 tetrafluoroethan) (N° CAS: 811-97-2)	CHEMICAL NATURE OF THE COMPOUND Mixture based on: Chlorodifluoromethane halogenated hydrocarbon N° CAS 75-45-6 EINECS 200-871-9
03	Identification of risk	Greatest physical and chemical dangers: Thermal decomposition in toxic and corrosive products	Effects on health: practically non-toxic Greatest physical and chemical dangers: Thermal decomposition in toxic and corrosive products Specific dangers/EEC: Dangerous for the ozone layer.
04	First-aid measures	General information: Inhalation: Carry the victim into the open air. Resort to oxygen or artificial respiration if necessary. Contact with skin: Frostbite must be treated in the same way as burns. Contact with the eyes: Immediate rinsing in abundant water. If irritation should continue, consult an ophthalmologist. Instructions for the physician: Do not administer catecolamine (due to the cardiac sensitisation provoked by the product)	General information: Inhalation: Carry the victim into the open air. Resort to oxygen or artificial respiration if necessary. Contact with skin: Frostbite must be treated in the same way as burns. Contact with the eyes: Immediate rinsing in abundant water. If irritation should continue, consult an ophthalmologist.

05	Fire prevention measures	<p>Specific dangers: Thermal decomposition into toxic and corrosive products. Hydrofluoric acid. Carbon oxides.</p> <p>Specific means of intervention: Cool containers/cisterns with jets of water. Prevent any sparks or flames. Do NOT smoke.</p> <p>Special protection systems for fire-fighting squads: Carry breathing apparatus and wear protective clothing</p>	<p>Specific dangers: Thermal decomposition into toxic and corrosive products. Hydrofluoric acid. Hydrochloric acid in gaseous form. Phosgene Carbon monoxides (CO).</p> <p>Specific means of intervention: Cool containers/cisterns with jets of water. Prevent any sparks or flames. Do NOT smoke.</p> <p>Special protection systems for fire-fighting squads: Carry breathing apparatus and wear protective clothing.</p>
06	Measures to take in case of accidental spillage	<p>Individual precautions: Avoid contact with the skin, eyes and inhalation of vapours. Use personal protection means. In an enclosed space: ventilate or use breathing apparatus (risk of anoxia). NO SMOKING ALLOWED</p> <p>Environment protection precautions: limit waste into environment with the greatest care.</p>	<p>Individual precautions: Avoid contact with the skin, eyes and inhalation of vapours. In an enclosed space: ventilate or use breathing apparatus (risk of suffocation). NO SMOKING ALLOWED. Remove all risk of sparks or flames.</p>
07	Manipulation and storage	<p>Technical measures/precautions. Form of storage and manipulation applicable to the products: PRESSURIZED GAS. Ensure adequate ventilation and evacuation for the level of equipment. Advice for use: Prevent sparks and contact with hot surfaces. DO NOT SMOKE. Technical measures/Storage procedures: Store at room temperature in the original container. Keep away from flames, hot surfaces and sparks. Store in a cool, well-ventilated place. Protect full containers from sources of heat to avoid excessive pressures. Recommended: Ordinary steel. Avoid: Alloy containing more than 2% magnesium. Plastics.</p>	<p>Technical measures/precautions. Form of storage and manipulation applicable to the products: PRESSURIZED GAS. Ensure adequate ventilation and evacuation for the level of equipment. Advice for use: Prevent sparks and contact with hot surfaces. DO NOT SMOKE. Technical measures/Storage procedures: Store at room temperature in the original container. Keep away from flames, hot surfaces and sparks. Store in a cool, well-ventilated place. Protect full containers from sources of heat to avoid excessive pressures. Recommended: Ordinary steel. Avoid: Alloy containing more than 2% magnesium. Plastics.</p>
08	Control of individual exposure/protection	<p>Precautionary measures to be taken: Ensure a sufficient exchange of air and/or suction in workplaces.</p> <p>Control parameters. Exposure limits: No limit value F-USA Forane 134a recommended limit value by Elf : VME=1000ppm Forane 32 recommended limit value by Elf : VME=1000ppm Forane 125 recommended limit value by Elf : VME=1000ppm</p> <p>Individual protective equipment: Respiratory protection: In case of insufficient ventilation, carry suitable breathing apparatus. Protection for the hands: Gloves Protection for the eyes: Protective eyewear</p>	<p>Precautionary measures to be taken: Ensure a sufficient exchange of air and/or suction in workplaces.</p> <p>Control parameters. Exposure limits: France 1989: VME = 1000 USA 1992: TWA = 1000 p.p.m. = 3500 mg/m3</p> <p>Individual protective equipment: Respiratory protection: In case of insufficient ventilation, carry suitable breathing apparatus. Protection for the hands: Gloves Protection for the eyes: Protective eyewear. Specific hygiene measures: avoid contact with the skin, eyes and inhalation of the vapours.</p>
09	Physical and chemical properties	<p>Physical state (20°C): liquid gas Colour: colourless Smell: Slightly similar to ether; pH: not applicable. Boiling point/interval: -42,4 °C Flash point: No flare up at test conditions Vapour pressure: (25°C): 1.13 Mpa (11,3 bar) a (50°C): 2.11 Mpa (21,1 bar) a (70°C): 3.26 Mpa (32,6 bar) Vapour density: At boiling point 4,54 kg/m3 Density: (25°C) 1133 kg/m3 a (50°C) 1004 kg/m3 (70°C) 861 kg/m3</p>	<p>Physical state (20°C): liquid gas Colour: colourless Smell: Slightly similar to ether; pH: not applicable. Boiling point/interval: -40.8 °C Melting point/interval: -160 °C Decomposition temperature: 480 °C Vapour pressure: (20 °C) 0.91 Mpa (9.1 bar); at 50 °C: 1.91 Mpa (19.4 bar) Vapour density: (20° C) 3.57 kg/m3 Solubility: water (25 °C) 3g/l - solvent soluble in hydrocarbons and chlorinated solvents, alcohols, ketones, esters. Solubility of water in the product at 30° C: 0.15% in weight.</p>
10	Stability and reactivity	<p>Conditions to avoid: Avoid contact with flames and red-hot metal surfaces. Dangerous decomposition products: Thermal decomposition into toxic and corrosive products: (hydrofluoric acid) Other Information: Stable product at normal storage and handling conditions</p>	<p>Conditions to avoid: Avoid contact with flames and red-hot metal surfaces. Dangerous decomposition products: Thermal decomposition into toxic and corrosive products: hydrofluoric acid, hydrochloric acid in gaseous form, phosgene, carbon monoxide (CO)</p>

11	Toxicological information	<p>Inhalation: In experiments on animals Forane 134a, 32, 125 practically non-toxic. No mortality noticed on rats at 500000 ppm/4h. As with other volatile aliphatic halogenated compounds, with the accumulation of vapours and/or the inhalation of large quantities, the product can cause: loss of consciousness and heart problems aggravated by stress and lack of oxygen; risk of death.</p> <p>Contact with skin: Frostbite possible from splashes of liquefied gas.</p> <p>Chronic toxicity: Studies on animal protracted inhalation do not highlight any sub-chronic toxic effect (rat/3 month(s)/ Inhalation: 50000ppm)</p> <p>Specific effects: Genotoxicity according experimental available data Forane 134a, 32, 125 NOT Genotoxic</p> <p>Carcinogenesis: Forane 134a: experiments on animals do not highlight carcinogen effect clearly demonstrated (rat /Inhalation – for oral administration)</p> <p>Toxicity for reproduction: Foetal growth Forane 134a, 32, 125 according to available data no toxic effect for foetal development. Fertility, according the limited data on animal: Forane 134a no effects on fertility (rats/inhalation)</p>	<p>Inhalation: Practically non-toxic in experiments conducted on animals. No effect below 50,000 p.p.m.</p> <p>As with other volatile aliphatic halogenated compounds, with the accumulation of vapours and/or the inhalation of large quantities, the product can cause: loss of consciousness and heart problems aggravated by stress and lack of oxygen; risk of death.</p> <p>Contact with skin: Frostbite possible from splashes of liquefied gas.</p> <p>Contact with the eyes: Temporary irritation.</p>
12	Ecological information	<p>Forane 32. Durability/degradability: Not easily biodegradable in water 5% after 28d Bioaccumulation: Practically non-absorbable by biological organisms log pow 0,21</p> <p>Forane 125 Mobility: Rapid evaporation t ½ life 3,2 h (estimate) Durability/degradability: Not easily biodegradable in water 5% after 28d. In the troposphere degradation at rate t ½ life 28,3 y (estimate). Potential for destruction of ozone ODP (R-11 = 1)=0. Potential greenhouse effect (GWP): (HGWP) = 0,58. Low absorption in ground and sediments log Koc= 1,3-1,7 Bioaccumulation: Practically non-absorbable by biological organisms log pow 1,48</p> <p>Forane 134a Mobility: Rapid evaporation t ½ vita 3 h (estimate) Durability/degradability: Not easily biodegradable in water 3% after 28d. 28d. In the atmosphere degradation at rate 3% after 28d . Potential for destruction of ozone ODP (R-11 = 1)=0. Potential greenhouse effect (GWP) 0,26. Bioaccumulation: Practically non-absorbable by biological organisms log pow 1,06</p>	<p>Mobility: Rapid evaporation: 1/2 life 2.7 h. Durability/degradability: Not easily biodegradable in water: 0% after 28 days. In the atmosphere degradation at rate of 1/2 life in 14 years. Potential for destruction of ozone ODP (R-11 = 1) = 0.055. Potential greenhouse effect (HGWP) - 0.36. Low absorption in ground and sediments log Koc = 1.8. Bioaccumulation: Practically non-absorbable by biological organisms: log pow 1.08. Aquatic toxicity: Acute toxicity, level of toxicity for fish over 24 hours = 180 mg/l; for anaerobic bacteria, level of toxicity over 24 hours > 400 mg/l.</p>
13	Notes concerning disposal	Disposal of product: recycle or incinerate.	Disposal of product: recycle.
14	Information on shipping	<p>Call ELF ATOCHEM safety services for updating and more information. ONU Number 3163. RID/ADR class 2 figure (and letter) 4°a</p> <p>Prescriptions: Labels 2 N° danger /N° material 20/3163</p> <p>IMDG class 2.2 N°ONU (IMDG) 3163</p> <p>Prescriptions: Labels 2.2</p> <p>IATA class 2.2 N°ONU (IATA) or N°ID3163</p> <p>Prescriptions: Labels 2.2</p>	<p>ONU number 1018. RID/ADR class 2 figure (and letter) 3° a</p> <p>Regulations: No. danger/No. material 20/1018 label 2</p> <p>IMDG class 2.2 ONU (IMDG) 1018</p> <p>Regulations: NON INFLAMMABLE GAS/2 label</p> <p>IATA class 2.2 ONU (IATA) or No.ID1018</p> <p>Regulations: NON INFLAMMABLE GAS/2 label</p> <p>Product code: 00055/7</p>
15	Information on regulation	<p>EEC directives</p> <p>Security reports: D.91/155/EEC modified by D.93/112/EEC: Dangerous substances</p> <p>EEC classification and labelling</p> <p>Dangerous preparation: Not classified as dangerous</p> <p>Inventory: in accordance with EINECS</p>	<p>EEC DIRECTIVES</p> <p>Security reports: D.91/155/EEC modified by D.93/112/EEC: Dangerous substances and manufactured compounds</p> <p>Dangerous manufactured compounds: D.67/548/CEE modified by D.93/21/CEE: Guide to labelling (18th APT).</p> <p>R59 Dangerous for the ozone layer S59 Consult producer/supplier for information concerning recovery and recycling.</p> <p>S61 Do not dump. Consult specific instructions and safety information.</p>
16	Other information	<p>Recommended uses: Refrigerant fluid</p> <p>Bibliographical references: Encyclopedie des gas (Air Liquide-ed.1976- ELSEVIER AMSTERDAM)</p>	<p>Recommended uses: low-temperature coolant, Freezing agent, Air conditioning.</p> <p>Bibliographical references: Encyclopédie des gas (Air liquide-ed. 1976 - ELSEVIER AMSTERDAM).</p> <p>INRS toxicological report: No. 142</p> <p>CHLOROFLUOROMETHANE</p>

This document refers to the product as is and which conforms to the specifications supplied by ELF ATOCHEM.

If combinations or mixtures are made, check that there are no new dangers resulting from this action. The information provided in this report has been provided in good faith and is based on our latest knowledge of the product in question as of the date of publication of the same. The attention of users is drawn to the potential risks of employing the product for any use other than that for which it is intended. This report must be used and reproduced solely for purposes of prevention and safety. The list of legislative, regulatory or administrative texts must not be considered exhaustive. The product user is under obligation to refer to all the official texts concerning the use, conservation and manipulation of the product for which he is sole responsible. The product user must also provide all those who might come into contact with the product with the information necessary for their safety at work and the protection of their health and that of the environment, giving them a copy of this safety information report.