



WATER CHILLER CONDENSERLESS
IT CAN BE COUPLED WITH REMOTE
CONDENSER CLIVET SERIES CEM

MSE-2 2.200-2.230-2.260-2.280-2.300-2.360-
2.400-2.440-3.450-3.540-3.580-3.620-3.660

WATER CONNECTIONS

CONTENTS:

GENERAL
CHILLED WATER CIRCUIT (EVAPORATOR)

WATER FILTER
PIPES FOR SAFETY VALVES

GENERAL

- Observe the safety regulations in force for an exact design and consecutive installation.
- Install ON/OFF valves next to the parts which are subject to maintenance. This allow their interchangeability without emptying the pipework.
- It is suggested to install thermometers and pressure gauges at the inlet/outlet of the heat exchangers. It will help the routine control and maintenance of the unit.
- It is suggested to install a steel mesh strainer on the suction side of the pump to protect the pump itself and the exchangers from extraneous materials.
- Control accurately the absence of leaks during the filling phase of the plumbing.
- Flow switches are part of the system and must be installed even if they aren't supplied with the unit. For their correct operation, they must be installed on a straight part of the pipe which is long at least 10 times the pipe diameter

CHILLED WATER CIRCUIT (EVAPORATOR)

The pipework must be designed with the minimum possible difference in height.

Automatic or manual vents shall be installed on the higher points of the chilled water piping to allow the outlet of the air in the circuit. The system can be kept at the right pressure by means of an expansion tank or of a combined pressure reduction-discharge valve.

All the pipework of the chilled water must be insulated in order to prevent the condensation on the piping itself. Make sure that the insulation is of the vapour seal type.

Make sure of the integrity of the piping (check for any leaks) before insulating it. Air-venting and draining connections must jut out of the insulation thickness to be accessible.

Danger of frost.

If the unit and its water connections are subject to temperatures lower than 0°C, specific actions must be taken to avoid frost on the exchanger and in the corresponding water circuit.

If the unit is fitted with an antifreeze heater (standard or optional, depending on the model) on the exchanger side, this must always be powered together with the heaters in the water circuit.

An antifreeze solution can be used (e.g. Ethylene Glycol) in the required percentage (see the Technical bulletin).

The water circuit (including the exchanger) can be drained during for seasonal shut-down.

Carefully check that there are no leaks from the pipes when filling the system.

HYDRAULIC CONNECTIONS ARE OF THE VICTAULIC TYPE.

INSTRUCTIONS FOR CONNECTIONS: (see Dimensions in General)

- Take off the solder pipe connection issued with the Victaulic coupling.
- Connect the evaporator to the pipeline by means of the Victaulic joint.

WARNING!

DO NOT WELD THE PIPEWORK AND THE EVAPORATOR CONNECTION PIPE IF THE VICTAULIC JOINT IS STILL CONNECTED. ITS RUBBER WASHER COULD BE IRREPARABLY DAMAGED

S SUGGESTED WATER CONNECTION DIAGRAM

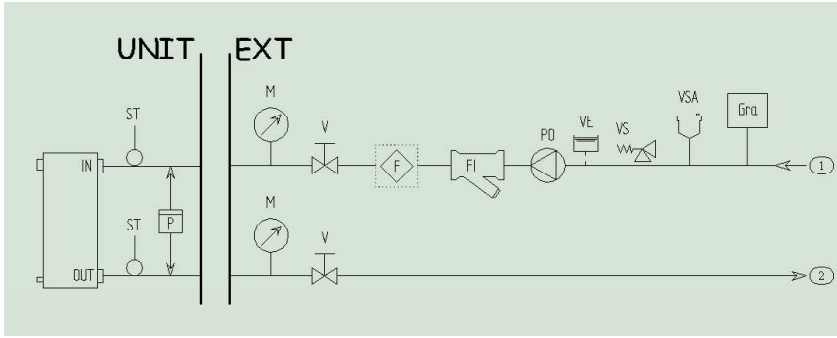

UNIT= unit
 EXT = exterior
 VS = water side safety valve
 P = differential pressure switch
 VE = expansion tank
 V = cock
 VSA = automatic air vent
 ST = water inlet and outlet probes
 F = flow switch
 PO = pump
 FI = water side filter (OPTIONAL)
 M = manometer
 GRA = filling valve
 1 = from the installation o
 2 = to the installation

INTERNAL EXCHANGER PRESSURE DROPS (EVAPORATOR): ST (STANDARD) - EN

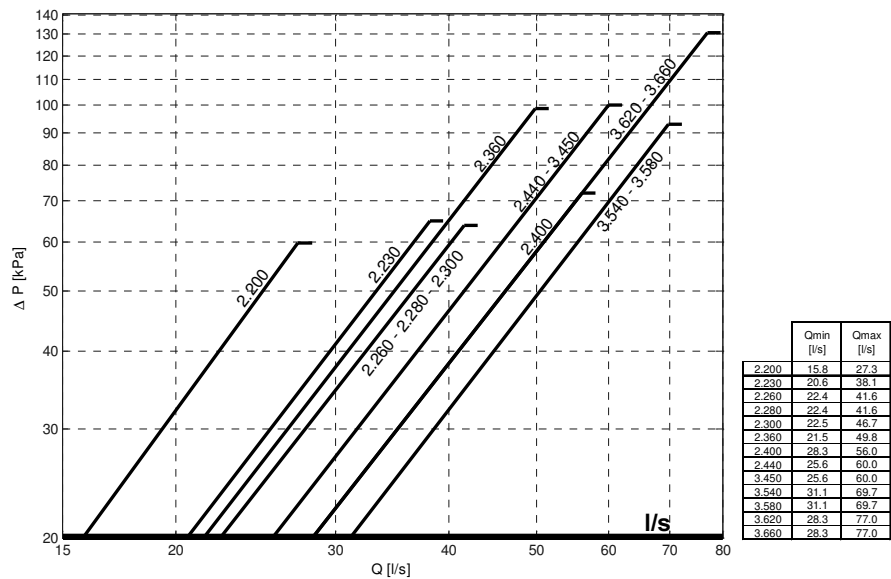

EVAPORATOR PRESSURE DROP.
 WARNING: DON'T USE BELOW THIS LIMIT

PIPES FOR SAFETY VALVES

The safety valves must be installed on the receivers or on the pipes connected to the receivers where there is presence of gases at a high or low pressure.

If no regulation is specific on this matter, it is a good principle to size the exhaust pipes so the pressure drop in the ducting does not exceed the safety valve calibration of a 10% (full flow rate)

In order to avoid injury to persons, the final opening of the exhaust piping should be at least at 4.5m from the floor and 6 meters from any window, ventilation opening or way out.

- Put a rain protection on the opening and a condensate drain on the lowest point of the piping.

- Insert a flexible piping in order to eliminate mechanical stress to the valves.

- An exhaust manifold can be used if more units are placed close to each other. The minimum dimension of the manifold and that of the exhaust pipe cannot be narrower than the sum of the areas of the exhaust connection valves.

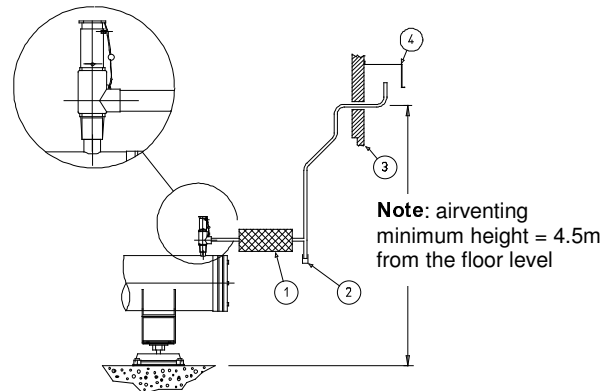

Note: airventing minimum height = 4.5m from the floor level

Key:

- 1-flexible coupling
- 2-condensate drain
- 3-wall
- 4-rain protection