



**CONDENSERLESS WATER CHILLER
FOR INDOOR INSTALLATION WITH
REMOTE CONDENSER**
IT CAN BE COUPLED WITH REMOTE
CONDENSER CLIVET SERIES CEM

MDE-3

2.160-2.180-2.200-2.220-2.250-

2.280-2.300-2.320-2.340-2.360-2.390-2.420-2.450-

2.480-3.480-3.500-3.520-3.540-3.570-3.600-3.630



R-134a

INSTALLATION, OPERATION AND MAINTENANCE MANUAL

GENERALE

THIS MANUAL CONTAINS THE FOLLOWING SECTIONS WHICH ARE TO BE CONSIDERED AN INTEGRAL PART OF THE WHOLE AND ARE THEREFORE NOT TO BE DETACHED

G3K0GB-1	R3K0GB-1	E3K0GB-1	F3K0GB-1	C3K0GB-1
General	Reception/Positioning	Electrical connections	Start-up	Controls
T3K0GB-1	M3K0GB-1	L3K0GB-1	P3K0GB-1	K3K0GB-1
Troubleshooting	Routine maintenance	Water connections	Refrigerant pipes	Residual risks

IMPORTANT

The contents of this manual are designed to assure the correct installation, adjustment and maintenance of the unit; therefore:

- read the instructions with due care and attention;
- the appliance must be installed, tested and serviced by properly qualified personnel (law n.45, 5.3.1990) licensed in accordance with established legislation.
- The manufacturer declines all liability, and guarantee coverage is automatically waived, if electrical and/or mechanical modifications are made to the unit. Tampering and unauthorised repairs or modifications to the unit will automatically void the guarantee.
- Observe the safety regulations in force at the time of installation.
- Make sure that the characteristics of the mains network conform to the data on the serial number plate inside the electrical panel.

- Conserve this manual and the circuit diagram with care. Make sure that they are available for consultation by the operator whenever necessary.
- Packing materials (plastic wrappings, expanded polystyrene, nails, etc.) are potentially hazardous and must be kept out of reach of children. Recycle packing materials in accordance with local bylaws.
- The water chiller must be used only for the purpose for which it is designed. The manufacturer bears no responsibility in the case of applications other than the specified use.
- Disconnect the unit in the case of breakdowns or malfunctions.
- If repairs are necessary use only Clivet-approved service centres and always insist on original spare parts. The use of non-original parts and/or unauthorised service centres may result in unsafe operation of the unit.

The manufacturer declines all liability for direct or indirect damage to property or injury to persons resulting from failure to adhere to the instructions in this manual.

ADDITIONAL SAFETY PRECAUTIONS

This unit has been especially designed and manufactured so to prevent any risk to persons and health hazard. For this reason, design solutions fit to eliminate (where possible) any cause of risk and sensibly reduce the probability of danger have been adopted.

Please refer to the **RESIDUAL RISKS** section of this manual and strictly observe the behaviour prescriptions listed there in order to prevent any possible risk that hasn't been possible to avoid in the design stage.

GENERAL TECHNICAL SPECIFICATIONS

ST (STANDARD) - EN

Sizes		2.160	2.180	2.200	2.220	2.250	2.280	2.300	2.320	2.340	2.360	2.390	2.420	2.450	2.480
Cooling capacity	1 kW	379.8	421.5	483.5	529.2	598.6	679.9	742.3	790.9	854.3	887.5	984.8	1053.6	1112.1	1131.4
Compressor power input	kW	110.8	122.2	137.9	155	178.3	192.8	210.2	227.5	241.2	257.2	278.9	303.1	311.9	324.2
Total power input	2 kW	111.4	122.8	138.5	155.6	178.9	193.4	210.8	228.1	242	258	279.7	303.9	312.8	325

Compressor															
Type of compressors		Twin-screw													
No. of Compressors	Nr	2	2	2	2	2	2	2	2	2	2	2	2	2	2
Nominal Power (C1)	HP	80	90	90	110	125	140	140	160	160	180	180	210	210	240
Nominal Power (C2)	HP	80	90	110	110	125	140	160	160	180	180	210	210	240	240
Std Capacity control steps	3 Nr	stepless													
Oil charge (C1)	l	15	15	15	22	22	22	22	28	28	28	28	28	28	28
Oil charge (C2)	l	15	15	22	22	22	22	28	28	28	28	28	28	28	28
Refrigerant circuits	Nr	2	2	2	2	2	2	2	2	2	2	2	2	2	2

Internal exchanger															
Type of internal exchanger		Tube bundle													
No. of internal exchangers	Nr	1	1	1	1	1	1	1	1	1	1	1	1	1	1
Water flow-rate	l/s	18.1	20.1	23.1	25.3	28.6	32.5	35.5	37.8	40.8	42.4	47	50.3	53.1	54.1
Pressure drop	kPa	22	22.9	34.5	40.9	23.7	27.4	38.2	42.9	53.2	57.1	35.5	40.3	53.8	55.5
Water content	l	162	184	222	222	295	383	462	462	423	423	406	406	475	475

Connections															
Gas connection		54/54	54/54	54/54	54/54	64/64	64/64	64/64	64/64	64/64	64/76	76/76	76/76	76/76	76/76
Liquid connection		35/35	35/35	35/42	42/42	42/42	42/42	42/54	54/54	54/54	54/54	54/54	54/54	54/54	54/54
Water fittings	4	6"	6"	6"	6"	8"	8"	8"	8"	8"	8"	8"	8"	8"	8"

Power supply															
Standard power supply	V	400/3/50													

The units are shipped with a sealed charge of nitrogen.

(1) data referred to the following conditions :

internal exchanger water = 12/7°C

condensing temperature = 50°C

(2) According to EUROVENT the Total Power Input does not consider the pump share, required to overcome the pressure drop for the solution circulation inside the exchangers.

(3) Continuous regulation power control (Stepless)

(4) Fittings with flexible joint and solder pipe connection

OPERATING LIMITS (COOLING) ST (STANDARD) - EN

Sizes		2.160	2.180	2.200	2.220	2.250	2.280	2.300	2.320	2.340	2.360	2.390	2.420	2.450	2.480
External exchanger															
Max condensing temperature	1 °C	60	60	60	60	60	60	60	60	60	60	60	60	60	60
Min. condensing temperature	1 °C	30	30	30	30	30	30	30	30	30	30	30	30	30	30
Internal exchanger															
Max water inlet temperature	°C	22	22	22	22	22	22	22	22	22	22	22	22	22	22
Min. water outlet temperature	2 °C	5	5	5	5	5	5	5	5	5	5	5	5	5	5
Min. water outlet temperature	3 °C	-8	-8	-8	-8	-8	-8	-8	-8	-8	-8	-8	-8	-8	-8

(1) Standard Version

internal exchanger water = 12/7°C

(2) Standard Version

(3) Low temperature version

Fluid with ethylene glycol of 40%

GENERAL TECHNICAL SPECIFICATIONS
ST (STANDARD) - EN

Sizes			3.480	3.500	3.520	3.540	3.570	3.600	3.630
Cooling capacity	1	kW	1185.4	1234.7	1306.3	1330.4	1392	1453.6	1515.2
Compressor power input		kW	341.3	354.8	368.5	385.8	410.4	435	459.6
Total power input	2	kW	342.3	355.8	369.5	386.9	411.4	436	460.6

Compressor									
Type of compressors			Twin-screw						
No. of Compressors		Nr	3	3	3	3	3	3	3
Nominal Power (C1)		HP	160	160	160	180	180	180	210
Nominal Power (C2)		HP	160	160	180	180	180	210	210
Nominal Power (C3)		HP	160	180	180	180	210	210	210
Std Capacity control steps	3	Nr	stepless						
Oil charge (C1)		l	28	28	28	28	28	28	28
Oil charge (C2)		l	28	28	28	28	28	28	28
Oil charge (C3)		l	28	28	28	28	28	28	28
Refrigerant circuits		Nr	3	3	3	3	3	3	3

Internal exchanger									
Type of internal exchanger			Tube bundle						
No. of internal exchangers		Nr	1	1	1	1	1	1	1
Water flow-rate		l/s	56.6	59	62.4	63.6	66.5	69.5	72.4
Pressure drop		kPa	42.5	45.8	61.6	63.7	69.5	75.5	81.7
Water content		l	483	483	565	565	565	565	565

Connections									
Gas connection			64/64/64	64/64/76	64/76/76	76/76/76	76/76/76	76/76/76	76/76/76
Liquid connection			54/54/54	54/54/54	54/54/54	54/54/54	54/54/54	54/54/54	54/54/54
Water fittings	4		8"	8"	8"	8"	8"	8"	8"

Power supply									
Standard power supply		V	400/3/50						

The units are shipped with a sealed charge of nitrogen.

(1) data referred to the following conditions :

internal exchanger water = 12/7°C

condensing temperature = 50°C

(2) According to EUROVENT the Total Power Input does not consider the pump share, required to overcome the pressure drop for the solution circulation inside the exchangers.

(3) Continuous regulation power control (Stepless)

(4) Fittings with flexible joint and solder pipe connection

OPERATING LIMITS (COOLING) ST (STANDARD) - EN

Sizes			3.480	3.500	3.520	3.540	3.570	3.600	3.630
External exchanger									
Max condensing temperature	1	°C	60	60	60	60	60	60	60
Min. condensing temperature	1	°C	30	30	30	30	30	30	30
Internal exchanger									
Max water inlet temperature		°C	22	22	22	22	22	22	22
Min. water outlet temperature	2	°C	6	6	6	6	6	6	6
Min. water outlet temperature	3	°C	-8	-8	-8	-8	-8	-8	-8

(1) Standard Version

internal exchanger water = 12/7°C

(2) Standard Version

(3) Low temperature version

Fluid with ethylene glycol of 40%

ACCESSORIES

On demand, these units can be supplied with the following optional accessories:

- it can be coupled with remote condenser clivet series cem
- compressor suction shut-off valve
- power factor correction capacitors (cosfi > 0.9)
- main door lock isolator switch (compulsory per have certification CE)
- compressor overload circuit breakers
- Free contacts for compressor state
- Free contacts for compressor state and enabling
- electronic expansion valves
- Master-Slave function
- set point compensation with outside temperature probe
- set point compensation with 4-20 mA or 0-10 V signal
- set point compensation according to the outside enthalpy
- double set point with units in "Brine" version
- data logger
- remote microprocessor control unit
- CAN/MODBUS serial converter kit
- rubber antivibration mounts

CONFIGURATION CODE

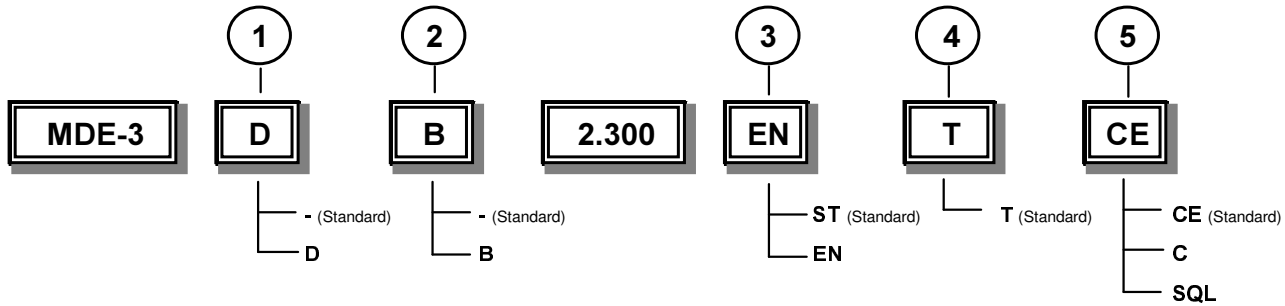

(1) ENERGY RECOVERY

Not required (-)

Partial Recovery (D)

it is achieved using tube bundle exchangers, suitable for recovering the heat from the desuperheating zone, up to a maximum of 20% of the total heat of the unit.

(2) LOW TEMPERATURE

Not required (-)

standard

Low water temperature (B)

this version allows unit operation in the range of water and glycol mix temperatures between +4°C and -8°C.

Two versions are available:

- Unit only for low temperatures.
- Unit with double operation set-point.

The availability of reduction capacity steps by means of compressor capacity control depends on the application

temperature range. Please call our commercial dept. for details. (Compatible with version: D)

(3) ACOUSTIC CONFIGURATION

Standard (ST)

Extremely low noise (EN)

this configuration is obtained by inserting the compressors in a soundproofed chamber.

(4) APPLICATION

Standard (T)

(5) HEAT EXCHANGERS APPROVALS

CE = PED (European testing)

C = CLIVET (Internal testing)

SQL

FOULING CORRECTION FACTORS ST (STANDARD) - EN

m ² °C/W	INTERNAL EXCHANGER	
	Cooling capacity correction factors	Compressor power input correction factor
0.44 x 10 ⁻⁴	1,00	1,00
0.88 x 10 ⁻⁴	0,97	0,99
1.76 x 10 ⁻⁴	0,94	0,98

EXCHANGER USE LIMITS: ST (STANDARD) - EN

	INTERNAL EXCHANGER		
	DPr kPa		DPw
	Standard	Low temperatures – B	kPa
CLIVET (C)	1650	1650	1600
PED (CE)	1650	1650	1600
SQL	1650	1650	1600

DPr = Maximum operating pressure on refrigerant side

DPw = Maximum operating pressure on water side

SETTING THE CUT-OUT DEVICES AND CONTROLS
ST (STANDARD) - EN

		OPEN	CLOSE	VALUE
High pressure switch		1730	1170	-
Low pressure switch	kPa	70	170	-
Low pressure safety valve	kPa	70	170	-
Low pressure safety valve (Brine)	bar	70	170	-
Antifreeze protection	°C	3	5.5	-
High pressure safety valve	kPa	-	-	2500
Low pressure safety valve	kPa	-	-	1650
Max no. of compressor starts per hour	Nr	-	-	6
High compressor discharge temperature safety thermostat	°C	-	-	120

Acoustic configuration: Standard (ST)

Size	Sound Power Level (dB)								Sound press. level dB(A)	Sound power level dB(A)
	Octave band (Hz)									
	63	125	250	500	1000	2000	4000	8000		
2.160	63	69	95	88	90	88	70	57	75	94
2.180	65	71	97	90	91	90	71	59	77	96
2.200	63	68	95	94	92	89	69	56	78	96
2.220	59	63	93	96	93	88	63	50	78	97
2.250	69	66	94	92	95	90	65	51	79	98
2.280	74	68	104	94	95	89	61	47	80	100
2.300	74	68	104	95	95	89	61	47	80	100
2.320	69	85	102	94	96	90	73	58	80	99
2.340	68	83	105	94	95	91	72	59	80	100
2.360	63	80	105	94	93	90	70	58	81	99
2.390	68	84	105	95	95	91	72	59	80	100
2.420	70	85	103	94	96	91	73	59	80	100
2.450	70	86	103	95	97	91	74	59	81	100
2.480	71	86	104	95	97	92	74	60	81	101
3.480	72	87	104	96	98	92	75	61	81	102
3.500	71	86	106	97	98	93	75	61	82	102
3.520	69	85	108	97	97	93	74	61	82	103
3.540	67	83	109	97	96	93	74	62	83	103
3.570	69	85	108	97	97	93	75	62	82	103
3.600	71	87	107	97	98	93	75	61	82	102
3.630	71	87	107	97	98	93	75	61	82	102

Acoustic configuration: Extremely low noise (EN)

Size	Sound Power Level (dB)								Sound press. level dB(A)	Sound power level dB(A)
	Octave band (Hz)									
	63	125	250	500	1000	2000	4000	8000		
2.160	58	64	90	77	77	79	57	46	66	85
2.180	60	65	92	79	79	80	59	47	68	87
2.200	58	63	90	83	80	79	57	44	68	87
2.220	54	57	88	85	81	78	51	38	68	87
2.250	64	61	89	81	83	81	53	39	68	87
2.280	69	62	99	83	82	79	49	35	73	92
2.300	69	62	100	83	82	79	49	35	73	92
2.320	64	79	97	83	83	80	60	46	71	91
2.340	62	78	100	83	82	81	60	47	73	92
2.360	58	74	100	83	80	80	58	46	74	93
2.390	63	78	100	84	83	81	60	47	73	93
2.420	65	80	98	83	84	81	61	47	72	91
2.450	65	80	98	84	84	82	62	47	72	92
2.480	66	81	99	84	85	82	62	48	73	92
3.480	66	82	100	85	86	83	63	49	73	93
3.500	65	81	102	86	85	83	63	49	74	94
3.520	64	80	103	86	85	84	62	49	75	95
3.540	62	78	104	86	84	84	61	50	76	96
3.570	64	80	103	86	85	84	62	50	75	95
3.600	66	81	102	86	85	84	63	49	74	95
3.630	66	81	102	86	85	84	63	49	74	95

the sound levels refer to the unit at full load, in the rated test conditions.

The sound pressure level refers to a distance of 1m from the external surface of the units operating in an open field.

data referred to the following conditions :

internal exchanger water = 12/7 °C

condensing temperature = 50 °C

DIMENSIONS Sizes 2.160-2.180-2.200-2.220-2.250

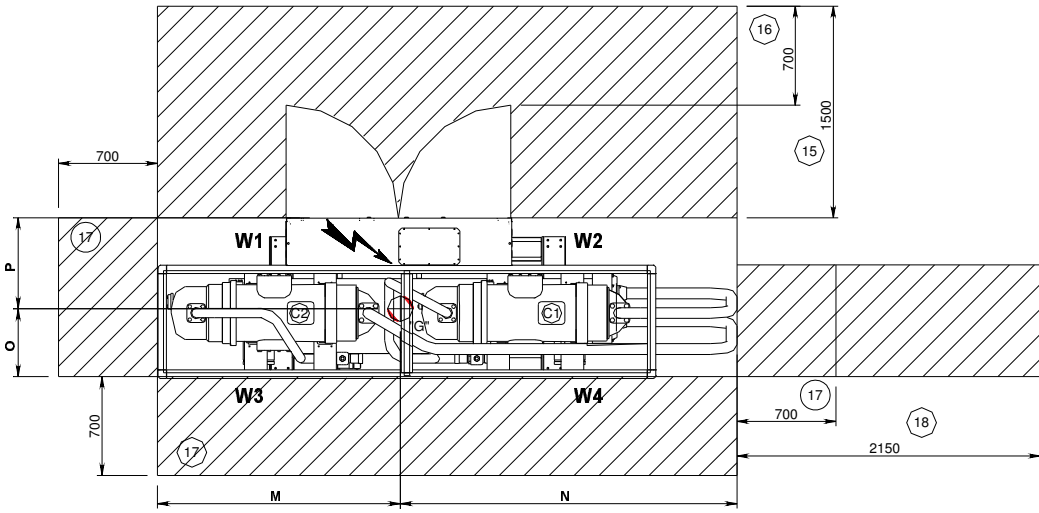
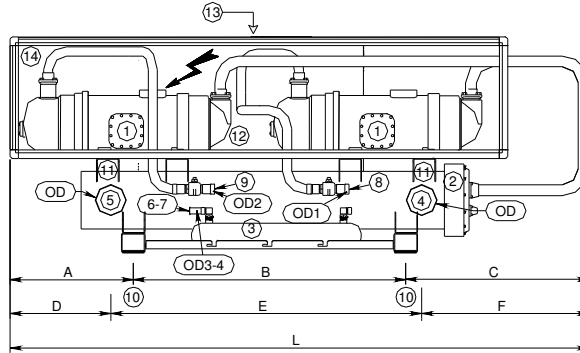
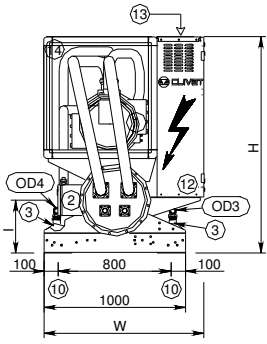

Key:

- (1) COMPRESSOR
- (2) INTERNAL EXCHANGER
- (3) LIQUID RECEIVER
- (4) INTERNAL EXCHANGER WATER INLET
- (5) INTERNAL EXCHANGER WATER OUTLET
- (6) CIRCUIT 1 LIQUID LINE SUCTION
- (7) CIRCUIT 2 LIQUID LINE SUCTION
- (8) OUTLET LINE SUCTION SHUT-OFF VALVE CIRCUIT 1
- (9) OUTLET LINE SUCTION SHUT-OFF VALVE CIRCUIT 2
- (10) HOLE TO HANG UNIT
- (11) LIFTING HOLES
- (12) ELECTRICAL PANEL
- (13) POWER INPUT

(14) SOUND PROOF ENCLOSURE (ONLY IN THE EXPECTED VERSIONS)

CLEARANCE ACCESS RECOMMENDED

- (15) MINIMUM DIMENSION ON THE ELECTRICAL SWITCHBOARD SIDE.
- (16) MINIMUM DIMENSION FOR A SAFE PASSAGE WHEN THE DOOR OF THE ELECTRICAL SWITCHBOARD IS OPEN.
- (17) MINIMUM DIMENSION FOR A SAFE PASSAGE.
- (18) MINIMUM DIMENSION FOR MAINTENANCE.
- C1 = CIRCUIT 1
- C2 = CIRCUIT 2

Sizes		DIMENSIONS ST/EN				
		2.160	2.180	2.200	2.220	2.250
A	mm	490	490	337	627	681
B	mm	2528	2528	2528	2528	2528
C	mm	918	918	1071	1071	1156
D	mm	642	642	242	532	629
E	mm	2200	2200	2700	2700	2630
F	mm	1094	1094	994	994	1106
H	mm	1700	1700	1700	1700	1700
I	mm	419	419	419	419	444
L	mm	3936	3936	3936	4226	4365
M	mm	1276	1276	1529	1496	1522
N	mm	2660	2660	2407	2730	2843
O	mm	487	487	487	485	486
P	mm	713	713	713	715	714
W	mm	1200	1200	1200	1200	1200
OD	mm	168.3	168.3	168.3	168.3	219.1
OD1	mm	54	54	54	54	64
OD2	mm	54	54	54	54	64
OD3	mm	35	35	35	42	42
OD4	mm	35	35	42	42	42

Sizes		WEIGHTS ST				
		2.160	2.180	2.200	2.220	2.250
W1	kg	602	632	739	820	906
W2	kg	536	564	659	731	807
W3	kg	642	674	789	884	972
W4	kg	572	602	704	787	866

Sizes		WEIGHTS EN				
		2.160	2.180	2.200	2.220	2.250
W1	kg	660	684	817	888	970
W2	kg	588	612	691	791	864
W3	kg	704	730	871	948	1040
W4	kg	628	653	738	844	927

DIMENSIONS Sizes 2.280-2.300-2.320-2.340-2.360-2.390-2.420-2.450-2.480

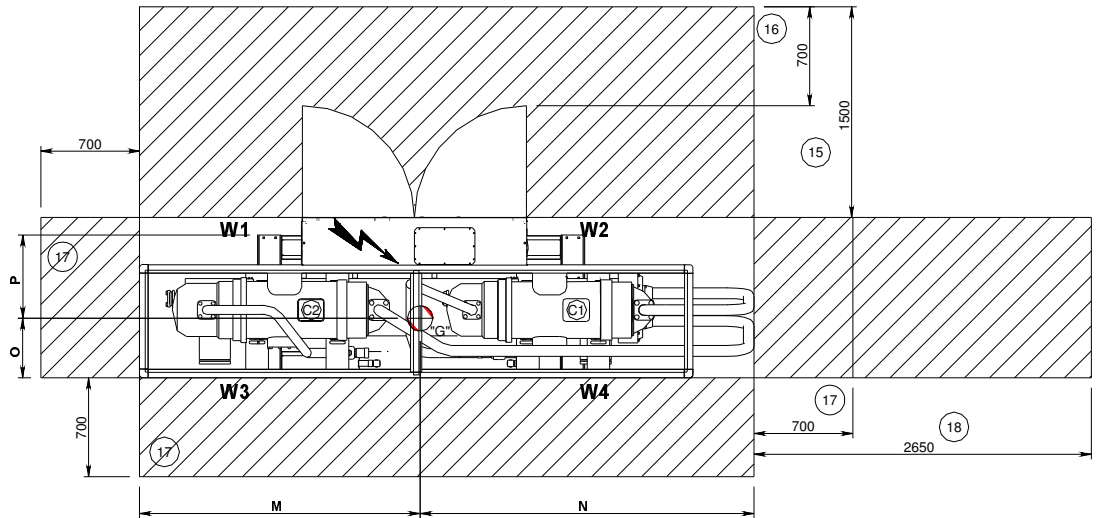
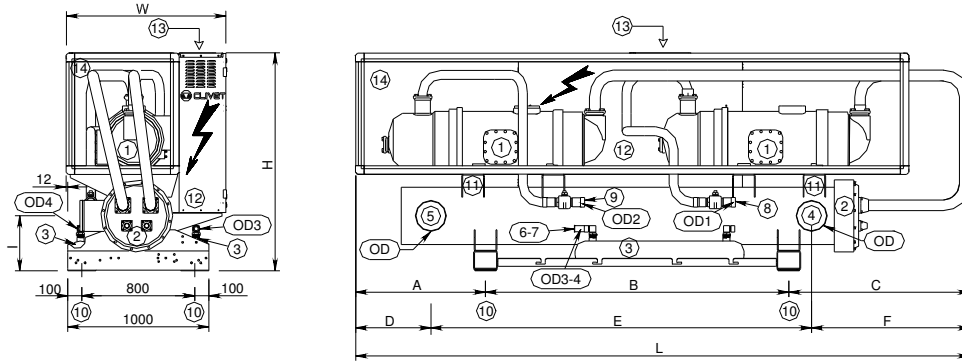

Key:

- (1) COMPRESSOR
- (2) INTERNAL EXCHANGER
- (3) LIQUID RECEIVER
- (4) INTERNAL EXCHANGER WATER INLET
- (5) INTERNAL EXCHANGER WATER OUTLET
- (6) CIRCUIT 1 LIQUID LINE SUCTION
- (7) CIRCUIT 2 LIQUID LINE SUCTION
- (8) OUTLET LINE SUCTION SHUT-OFF VALVE CIRCUIT 1
- (9) OUTLET LINE SUCTION SHUT-OFF VALVE CIRCUIT 2
- (10) HOLE TO HANG UNIT
- (11) LIFTING HOLES
- (12) ELECTRICAL PANEL
- (13) POWER INPUT

- (14) SOUND PROOF ENCLOSURE (ONLY IN THE EXPECTED VERSIONS)
- CLEARANCE ACCESS RECOMMENDED**
- (15) MINIMUM DIMENSION ON THE ELECTRICAL SWITCHBOARD SIDE.
- (16) MINIMUM DIMENSION FOR A SAFE PASSAGE WHEN THE DOOR OF THE ELECTRICAL SWITCHBOARD IS OPEN.
- (17) MINIMUM DIMENSION FOR A SAFE PASSAGE.
- (18) MINIMUM DIMENSION FOR MAINTENANCE.
- C1 = CIRCUIT 1
- C2 = CIRCUIT 2

Sizes	DIMENSIONS ST/EN									
	2.280	2.300	2.320	2.340	2.360	2.390	2.420	2.450	2.480	
A	mm	590	921	771	849	849	878	878	886	886
B	mm	2528	2528	2528	2150	2150	2150	2150	2150	2150
C	mm	1352	1261	1411	1861	1861	1699	1699	1907	1907
D	mm	288	620	470	469	469	727	747	395	395
E	mm	3130	3130	3130	3130	3130	2620	2620	3130	3130
F	mm	1052	960	1110	1261	1261	1380	1360	1418	1418
H	mm	2000	2000	2000	2000	2000	2000	2000	2000	2000
I	mm	462	462	362	447	447	505	505	505	505
L	mm	4470	4710	4710	4860	4860	4727	4727	4943	4943
M	mm	1782	1782	1782	2066	2066	2065	2066	2064	2064
N	mm	2688	2928	2928	2794	2794	2662	2661	2879	2879
O	mm	488	487	484	486	486	488	487	425	425
P	mm	812	813	816	814	814	812	813	875	875
W	mm	1300	1300	1300	1300	1300	1300	1300	1300	1300
OD	mm	219.1	219.1	219.1	219.1	219.1	219.1	219.1	219.1	219.1
OD1	mm	64	64	64	64	76	76	76	76	76
OD2	mm	64	64	64	76	76	76	76	76	76
OD3	mm	42	42	54	54	54	54	54	54	54
OD4	mm	42	54	54	54	54	54	54	54	54

Sizes	WEIGHTS ST									
	2.280	2.300	2.320	2.340	2.360	2.390	2.420	2.450	2.480	
W1	kg	930	1114	1209	1126	1128	1187	1197	1092	1096
W2	kg	830	994	1079	1213	1215	1277	1290	1172	1176
W3	kg	987	1188	1310	1207	1210	1261	1278	1596	1601
W4	kg	881	1060	1169	1301	1304	1356	1377	1713	1719

Sizes	WEIGHTS EN									
	2.280	2.300	2.320	2.340	2.360	2.390	2.420	2.450	2.480	
W1	kg	994	1156	1285	1196	1201	1252	1263	1154	1151
W2	kg	887	1032	1147	1288	1294	1344	1363	1239	1236
W3	kg	1056	1304	1392	1282	1282	1343	1354	1678	1691
W4	kg	942	1164	1242	1381	1381	1442	1462	1801	1815

DIMENSIONS Sizes 3.480-3.500-3.520-3.540-3.570-3.600-3.630

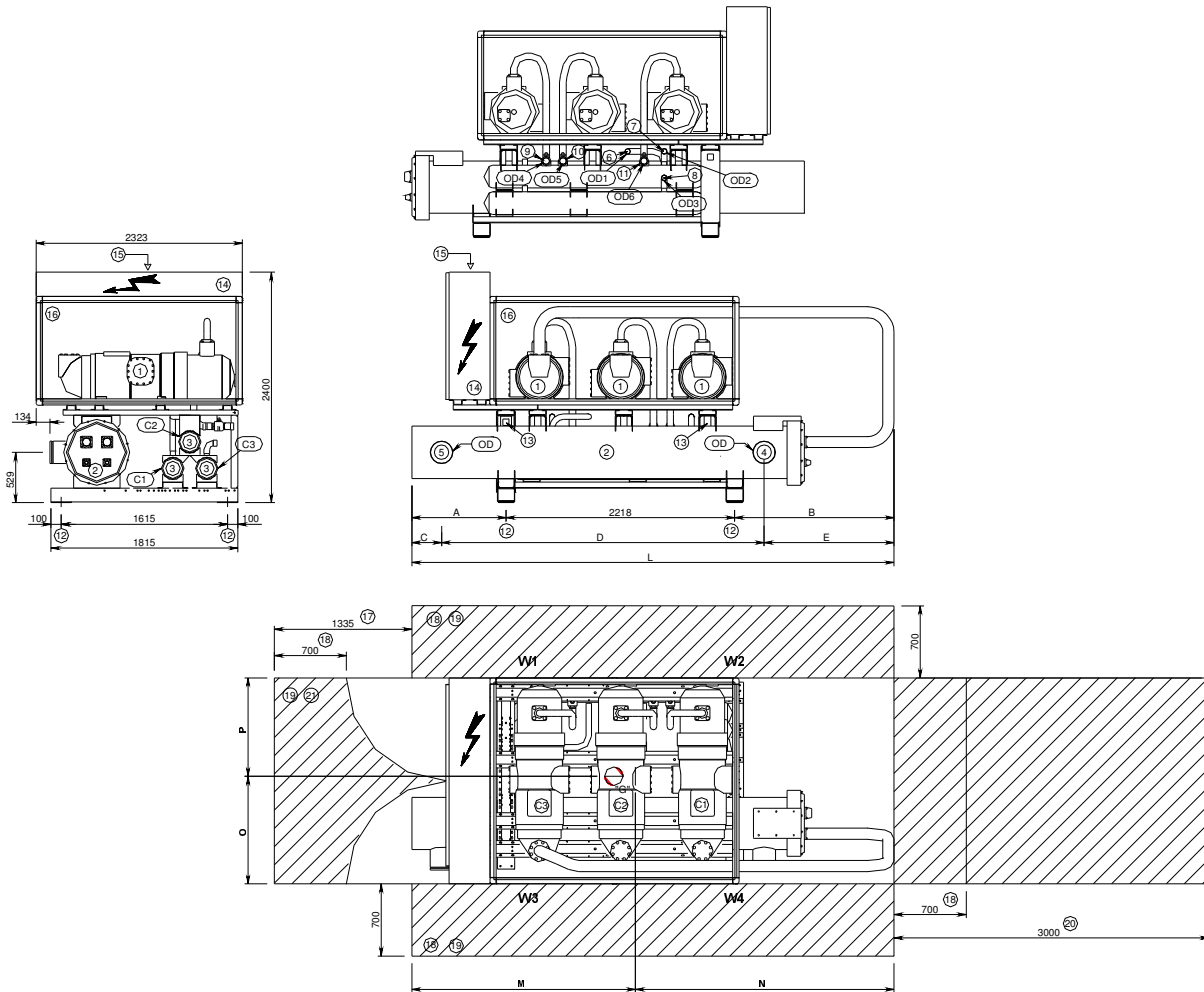

Key:

- (1) COMPRESSOR
- (2) INTERNAL EXCHANGER
- (3) LIQUID RECEIVER
- (4) INTERNAL EXCHANGER WATER INLET
- (5) INTERNAL EXCHANGER WATER OUTLET
- (6) CIRCUIT 1 LIQUID LINE SUCTION
- (7) CIRCUIT 2 LIQUID LINE SUCTION
- (8) CIRCUIT 3 LIQUID LINE SUCTION
- (9) OUTLET LINE SUCTION SHUT-OFF VALVE CIRCUIT 1
- (10) OUTLET LINE SUCTION SHUT-OFF VALVE CIRCUIT 2
- (11) OUTLET LINE SUCTION SHUT-OFF VALVE CIRCUIT 3
- (12) HOLE TO HANG UNIT
- (13) LIFTING HOLES
- (14) ELECTRICAL PANEL
- (15) POWER INPUT
- (16) SOUND PROOF ENCLOSURE (ONLY IN THE EXPECTED VERSIONS)
- CLEARANCE ACCESS RECOMMENDED**
- (17) MINIMUM DIMENSION ON THE ELECTRICAL SWITCHBOARD SIDE.
- (18) MINIMUM DIMENSION FOR A SAFE PASSAGE.
- (19) MINIMUM DIMENSION FOR MAINTENANCE.
- (20) MINIMUM DIMENSIONS FOR TUBE BUNDLE EXTRACTION.
- (21) MINIMUM DIMENSION FOR A SAFE PASSAGE WHEN THE DOOR OF THE ELECTRICAL SWITCHBOARD IS OPEN.
- C1= CIRCUIT 1
- C2= CIRCUIT 2
- C3=CIRCUIT 3

Sizes		DIMENSIONS ST/EN						
		3.480	3.500	3.520	3.540	3.570	3.600	3.630
A	mm	895	895	1156	1156	1156	1156	1156
B	mm	1387	1387	1386	1386	1386	1386	1386
C	mm	578	578	338	338	338	338	338
D	mm	2630	2630	3130	3130	3130	3130	3130
E	mm	1292	1292	1292	1292	1292	1292	1292
L	mm	4500	4500	4760	4760	4760	4760	4760
M	mm	2451	2451	2451	2451	2451	2451	2451
N	mm	2049	2049	2309	2309	2309	2309	2309
O	mm	1247	1247	1247	1247	1247	1247	1247
P	mm	1076	1076	1076	1076	1076	1076	1076
OD	mm	219,1	219,1	219,1	219,1	219,1	219,1	219,1
OD1	mm	64	64	64	76	76	76	76
OD2	mm	64	64	76	76	76	76	76
OD3	mm	64	76	76	76	76	76	76
OD4	mm	54	54	54	54	54	54	54
OD5	mm	54	54	54	54	54	54	54
OD6	mm	54	54	54	54	54	54	54

Sizes		WEIGHTS ST						
		3.480	3.500	3.520	3.540	3.570	3.600	3.630
W1	kg	1752	1760	1846	1848	1866	1885	1894
W2	kg	2020	2030	2129	2132	2153	2174	2185
W3	kg	1834	1842	1933	1935	1954	1973	1983
W4	kg	2115	2125	2229	2232	2254	2276	2287

Sizes		WEIGHTS EN						
		3.480	3.500	3.520	3.540	3.570	3.600	3.630
W1	kg	1835	1848	1930	1934	1950	1968	1978
W2	kg	2117	2127	2226	2226	2249	2270	2281
W3	kg	1926	1934	2025	2029	2046	2066	2076
W4	kg	2222	2227	2336	2337	2360	2382	2394