

EN CAS DE RISQUE DE GEL L APPAREIL DEVRA ETRE VIDANGE
 IN THE CASE OF RISK OF FREEZING THE UNIT MUST BE DRAINED

OPTION PLOTS ANTIVIBRATILS
 OPTION ANTIVIBRATION

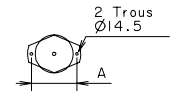

CIATCOOLER	Nbre de plots Number of vibra- tionless suspension	Durete Shores	Diametre	A	H
1000	8	45	200	240	37
1202	8	45	200	240	37

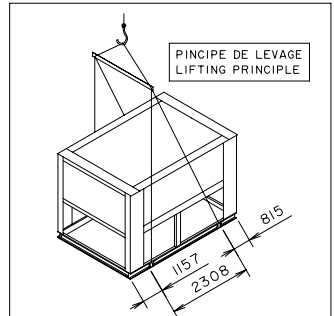
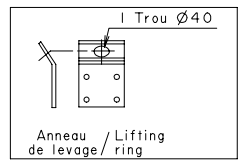

NOTA: Ne font pas partie des fournitures des groupes de refroidissement type CIATCOOLER LCT le cablage, le sectionneur fusible ou le disjoncteur entre le tableau électrique et le réseau (à prévoir impérativement par l'installateur) Prevoir un dégagement de 2m tout autour de l'unité pour l'entretien.
 -Le raccordement électrique ⑤ s'effectue par le dessous du tableau électrique.
 → Aspiration air condenseur
 → Soufflage air condenseur
 -Aucun obstacle ne devra gêner le refoulement de l'air.

NOTES: Excluded from the supply of CIATCOOLER type LCT water chillers are isolators or fused switchgear and associated wiring between the electric panel and supply system (these must be provided by the installer)
 -Allow 2m of clearance all around the unit for maintenance.
 -the electrical connections ⑤ are made to the below of the electrical panel.
 → Condenseur air inlet
 → Condenseur air discharge
 -No obstruction to the air discharge should be allowed.

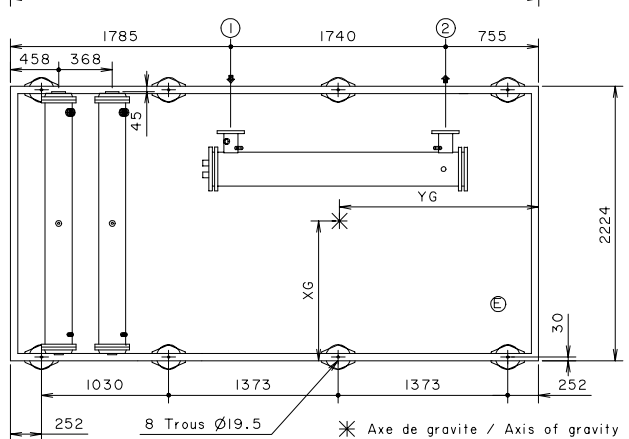

- ① Entree eau glatee bride PN16 DN 100 / Chilled water inlet flanged PN16 DN 100
- ② sortie eau glatee bride PN16 DN 100 / Chilled water outlet flanged PN16 DN 100
- ③ Entree eau chaude manchon 2" / Hot water inlet sleeves 2"
- ④ Sortie eau chaude manchon 2" / Hot water outlet sleeves 2"

CIATCOOLER LC	Poids a vide en kg Weight in kg	Poids en service en kg Weight operational in kg	LCT	XG	YG
LCT 1000	3410	3510	1000	1032	2088
LCT 1202	3560	3660	1202	1027	2116

H.D	32	POSITION EVAPORATEUR STANDARD LC LCH	
MODIFIE PAR	IND	NETUDE	DATE
APPAREIL OU UNITE		MODIFICATION	
LCT 1000 ET 1202 2 CIRCUITS		MATIERES:	
DESIGNATION		ECHELLE	
ENCOMBREMENT/DIMENSION		TRAITEMENT	
NUMERO DE COMMANDE:		MASSE:	
NOTE D'ETUDE:		REPLACE PAR:	
VERIFIE PAR:		REPLACE:	
DESSIN PAR:		FORMAT	
EXCOFFON B.		A3	
DATE: 15/04/94		NUMERO DE PLAN	
		3976612	
		INDICE	
		32	



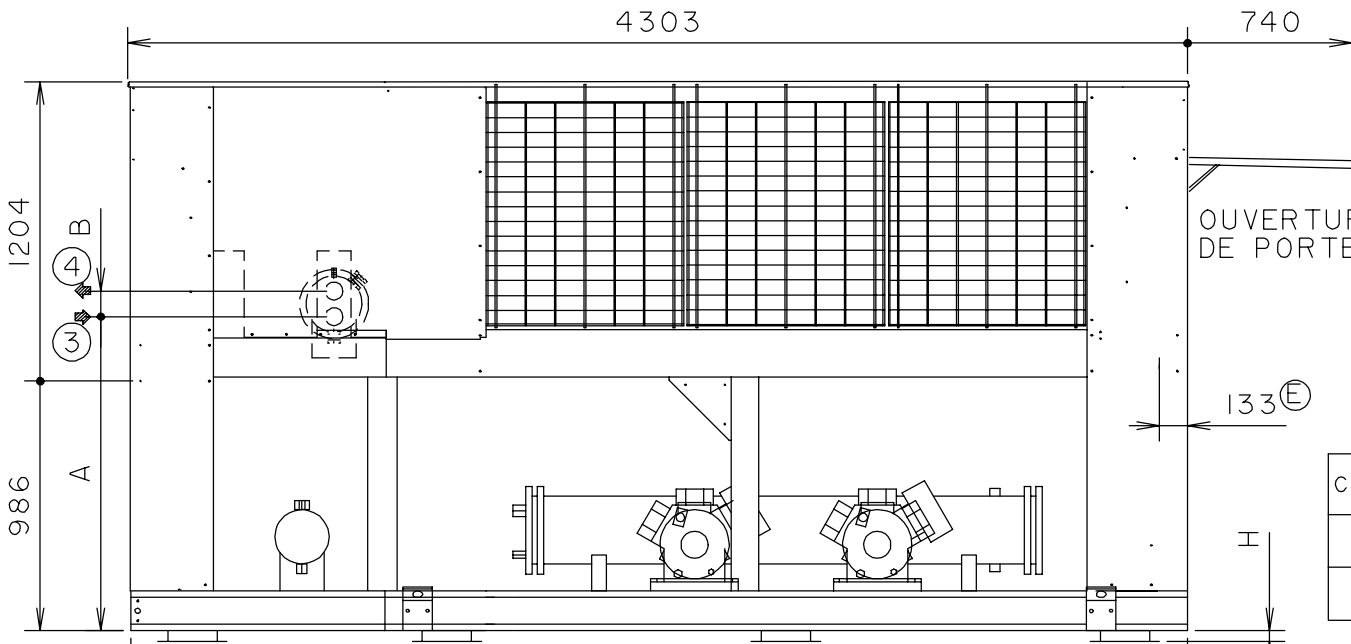
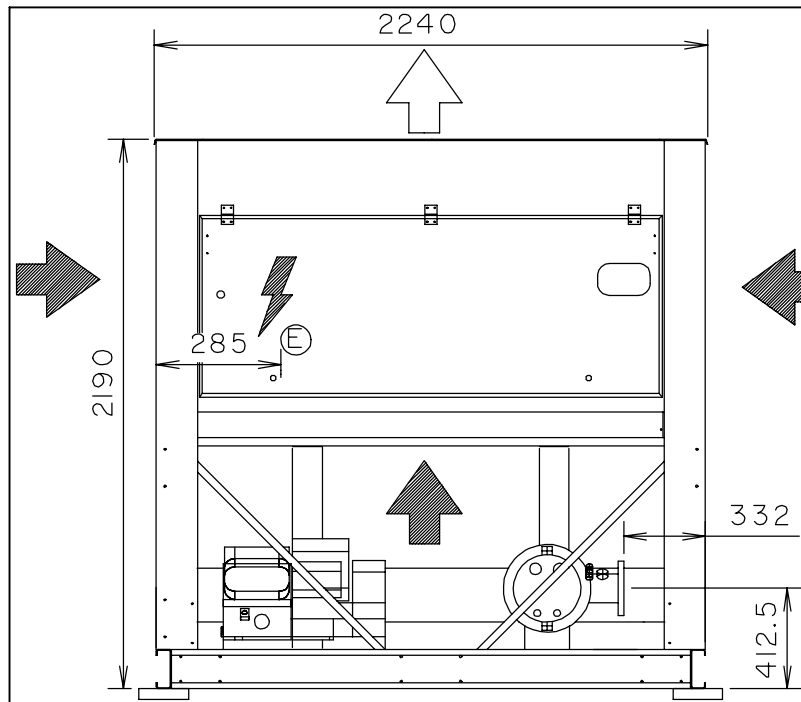

EN CAS DE RISQUE DE GEL L APPAREIL DEVRA ETRE VIDANGE
 IN THE CASE OF RISK OF FREEZING THE UNIT MUST BE DRAINED

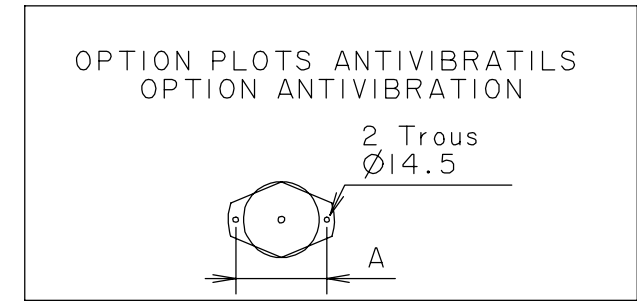

CIATCOOLER	Nbre de plots Number of vibrationless suspension	Durete Shores	Diametre	A	H
1000	8	45	200	240	37
1202	8	45	200	240	37

NOTA: Ne font pas partie des fournitures des groupes de refroidissement type CIATCOOLER LCT le cablage, le sectionneur fusible ou le disjoncteur entre le tableau électrique et le réseau (à prévoir impérativement par l'installateur) Prevoir un dégagement de 2m tout autour de l'unité pour l'entretien.
 -Le raccordement électrique (E) s'effectue par le dessous du tableau électrique.
 ➔ Aspiration air condenseur
 ➔ Soufflage air condenseur
 -Aucun obstacle ne devra gêner le refoulement de l'air.

NOTES: Excluded from the supply of CIATCOOLER type LCT water chillers are isolators or fused switchgear and associated wiring between the electric panel and supply system (these must be provided by the installer)
 -Allow 2m of clearance all around the unit for maintenance.
 -the electrical connections (E) are made to the below of the electrical panel.
 ➔ Condenseur air inlet
 ➔ Condenseur air discharge
 -No obstruction to the air discharge should be allowed.

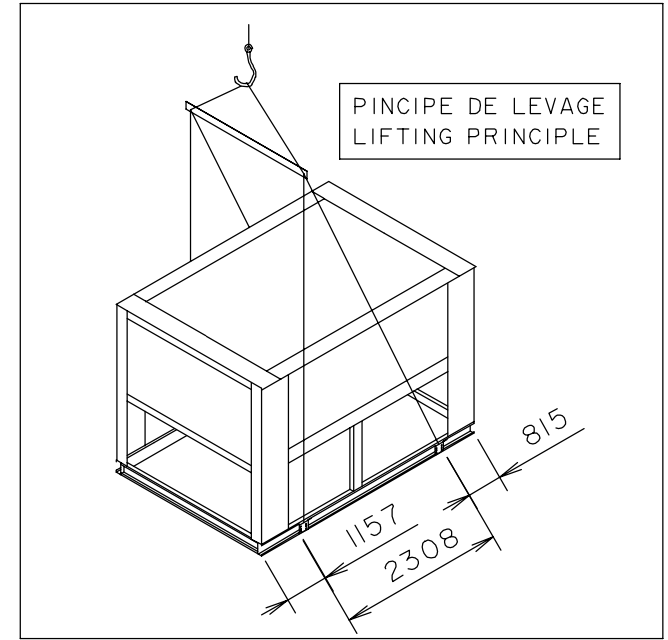
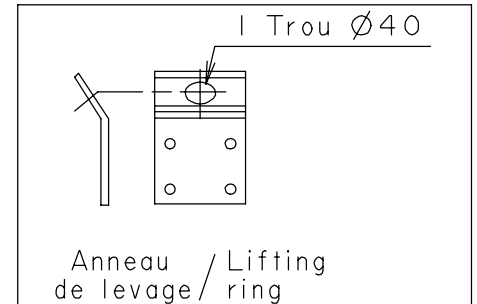
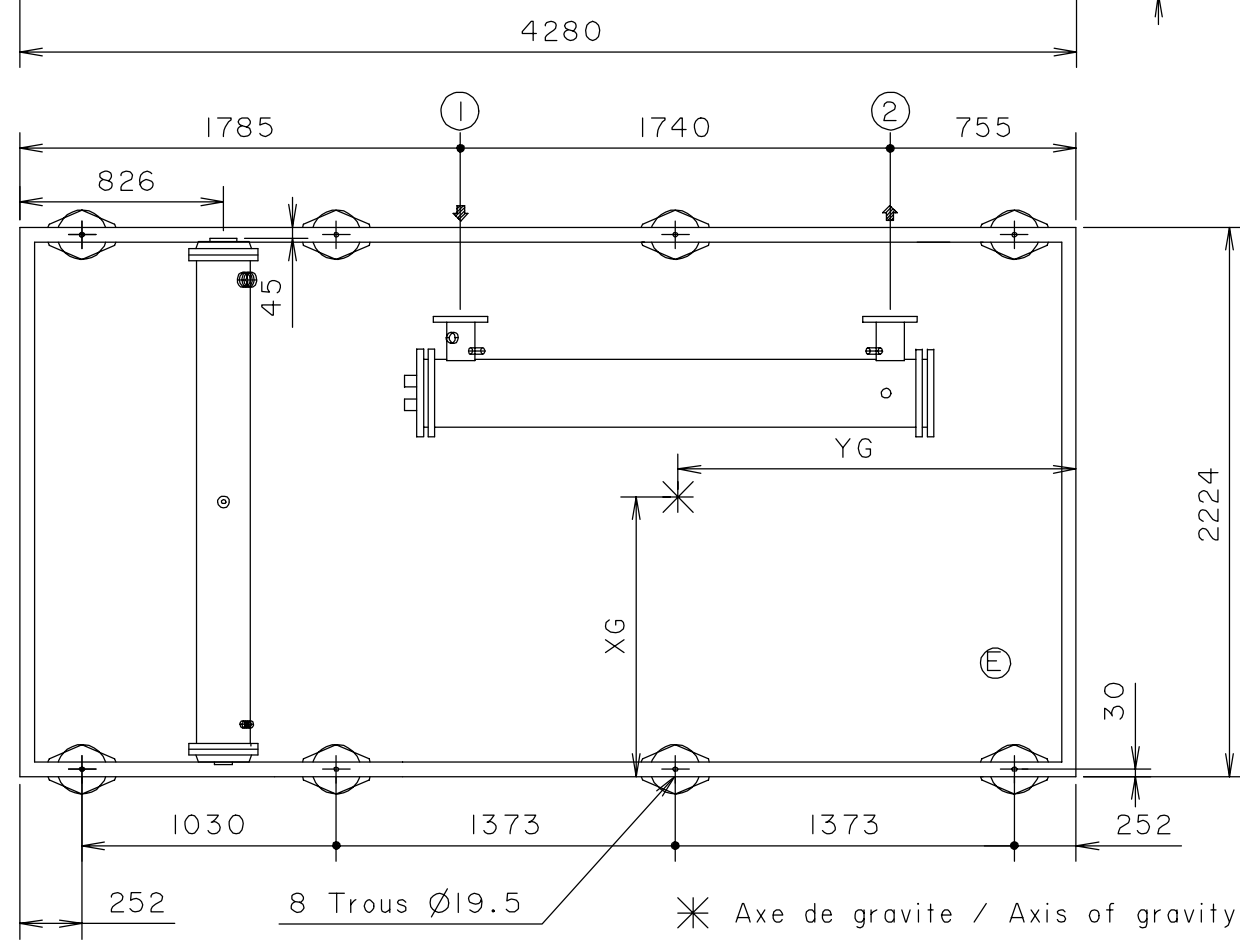

- ① Entree eau glacee bride PN16 DN 100 / Chilled water inlet flanged PN16 DN 100
- ② sortie eau glacee bride PN16 DN 100 / Chilled water outlet flanged PN16 DN 100
- ③ Entree eau chaude manchon / Hot water inlet sleeves
- ④ Sortie eau chaude manchon / Hot water outlet sleeves

	Ø Manchon
LCT 1000	2"1/2
LCT 1202	3"

CIATCOOLER LC	Poids a vide en kg Weight in kg	Poids en service en kg Weight operational in kg
LCT 1000	3240	3310
LCT 1202	3510	3600

LCT	XG	YG	A	B
1000	1032	1943	1291	130
1202	1027	1970	1311	172

H.D	33	13.10.00	POSITION EVAPORATEUR STANDARD LC LCH						
MODIFIE PAR	IND	N.ETUDE	DATE						
		APPAREIL OU UNITE	MATIERE:						
		LCT 1000 ET 1202 IC							
		DESIGNATION	ECHELLE						
		ENCOMBREMENT/DIMENSION	TRAITEMENT						
		NUMERO DE COMMANDE:	MASSE:						
		NOTE D'ETUDE: DATE:	REPLACE PAR:						
		VERIFIE PAR: DATE:	REPLACE:						
		DESSIN PAR: EXCOFFON B. DATE: 14/06/94	<table border="1"> <tr> <td>FORMAT</td> <td>NUMERO DE PLAN</td> <td>INDICE</td> </tr> <tr> <td>A3</td> <td>3976644</td> <td>33</td> </tr> </table>	FORMAT	NUMERO DE PLAN	INDICE	A3	3976644	33
FORMAT	NUMERO DE PLAN	INDICE							
A3	3976644	33							

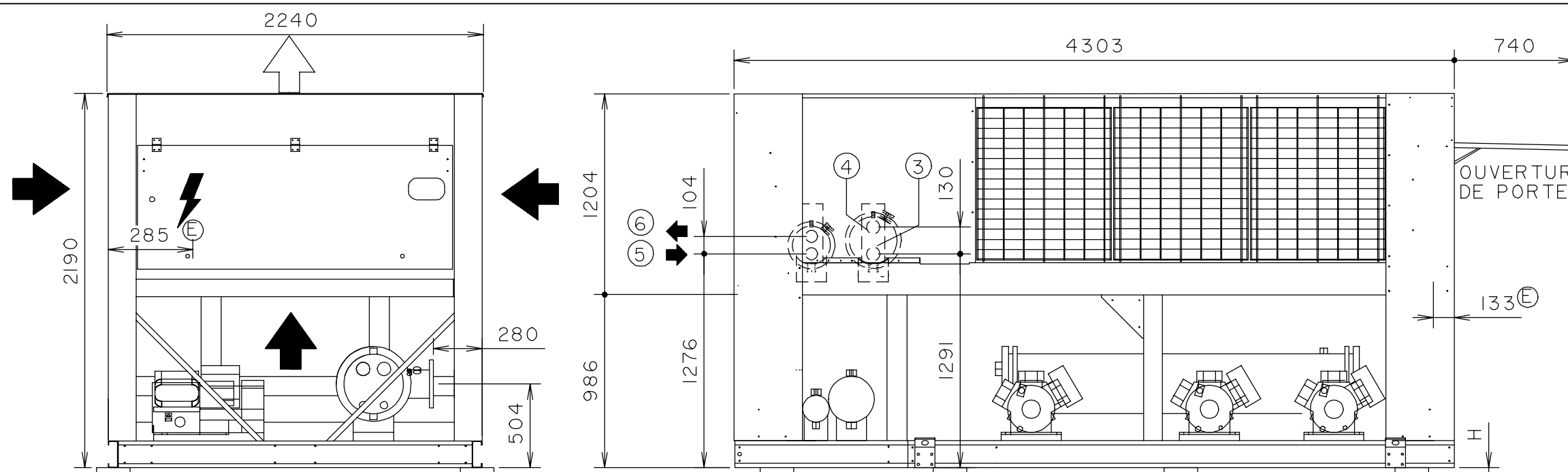

EN CAS DE RISQUE DE GEL L APPAREIL DEVRA ETRE VIDANGE
 IN THE CASE OF RISK OF FREEZING THE UNIT MUST BE DRAINED

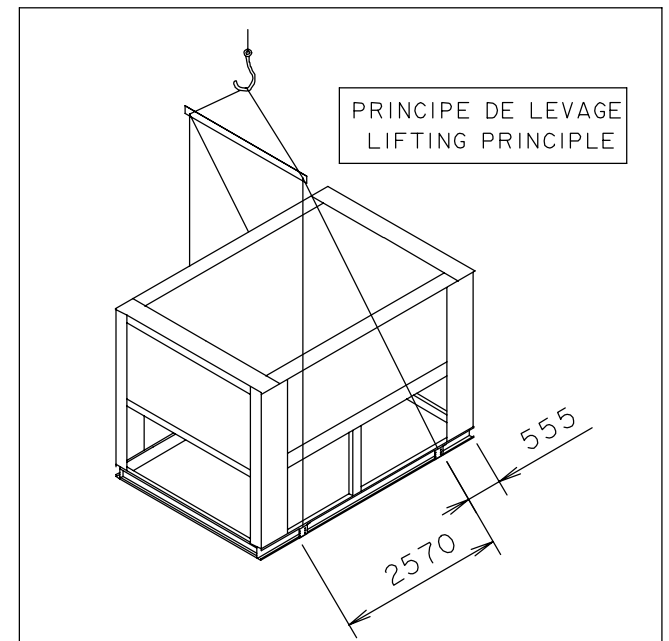
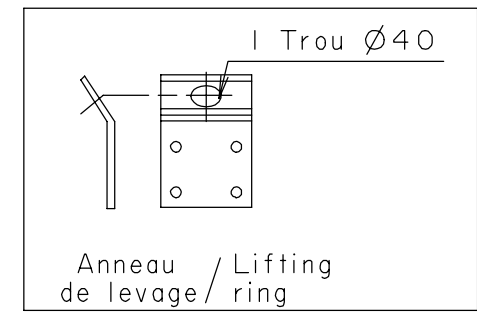
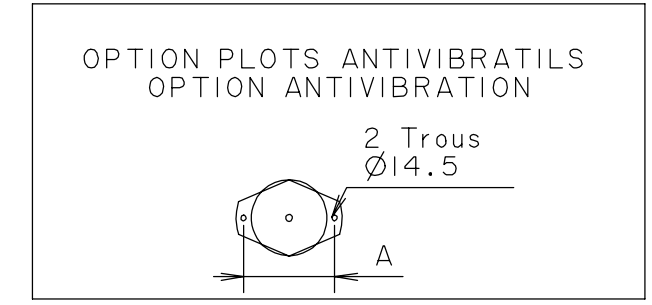

CIATCOOLER	Nbre de plots Number of vibrationless suspension	Durete Shores	Diametre	A	H
1203	8	60	200	240	37

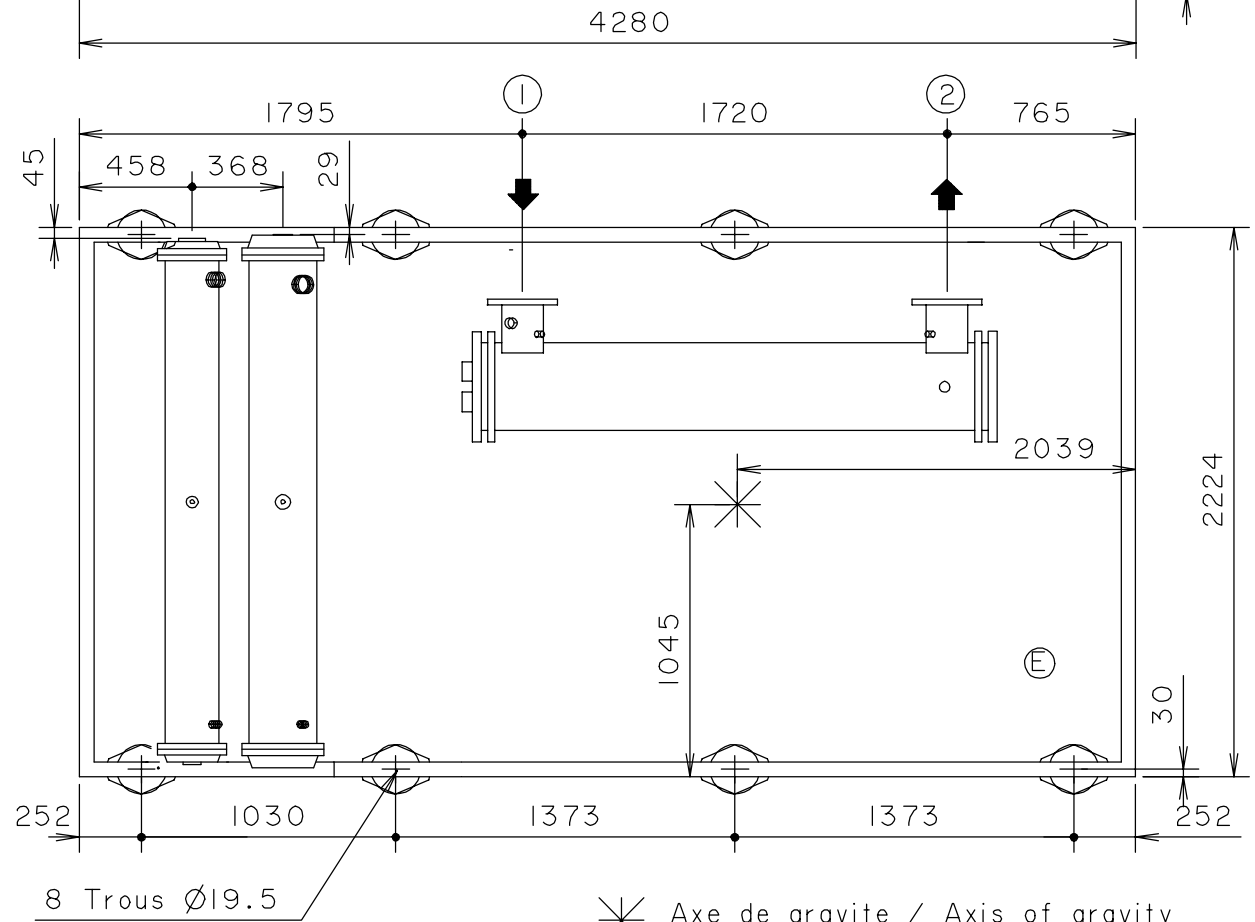

NOTA: Ne font pas partie des fournitures des groupes de refroidissement type CIATCOOLER LCT le cablage, le sectionneur fusible ou le disjoncteur entre le tableau électrique et le réseau (à prévoir impérativement par l'installateur) Prevoir un dégagement de 2m tout autour de l'unité pour l'entretien.
 -Le raccordement électrique (E) s'effectue par le dessous du tableau électrique.
 ➔ Aspiration air condenseur
 ⇨ Soufflage air condenseur
 -Aucun obstacle ne devra gêner le refoulement de l'air.

NOTES: Excluded from the supply of CIATCOOLER Type LCT water chillers are isolators or fused switchgear and associated wiring between the electric panel and supply system (these must be provided by the installer)
 -Allow 2m of clearance all around the unit for maintenance.
 -the electrical connections (E) are made to the below of the electrical panel.
 ➔ Condenseur air inlet
 ⇨ Condenseur air discharge
 -No obstruction to the air discharge should be allowed.

- ① Entree eau glcee bride PN16 DN 125 / Chilled water inlet flanged PN16 DN 125
 - ② sortie eau glcee bride PN16 DN 125 / Chilled water outlet flanged PN16 DN 125
 - ③ Entree eau chaude manchon 2" 1/2 / Hot water inlet sleeves 2" 1/2
 - ④ Sortie eau chaude manchon 2" 1/2 / Hot water outlet sleeves 2" 1/2
 - ⑤ Entree eau chaude manchon 2" / Hot water inlet sleeves 2"
 - ⑥ Sortie eau chaude manchon 2" / Hot water outlet sleeves 2"
- } Circuit 1
 } Circuit 2

CIATCOOLER LC	Poids a vide en kg Weight in kg	Poids en service en kg Weight operational in kg
LCT 1203	4020	4120

✱ Axe de gravite / Axis of gravity

H.D	33	13.10.00	POSITION EVAPORATEUR STANDARD LC LCH
MODIFIE PAR	IND	N.ETUDE	DATE
		APPAREIL OU UNITE LCT 1203 6H	MATIERE:
		DESIGNATION ENCOMBREMENT/DIMENSION	ECHELLE TRAITEMENT
		NUMERO DE COMMANDE:	FOLIO 1/1 REMPLECE PAR:
		NOTE D'ETUDE: DATE:	REMPLECE:
		VERIFIE PAR: DATE:	FORMAT A3
		DESSIN PAR: BE DATE: 10/05/94	NUMERO DE PLAN 3976624
			INDICE 33

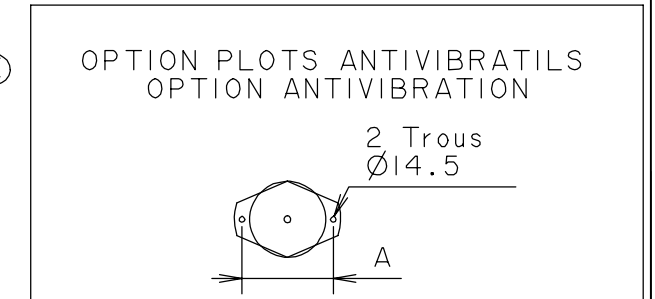
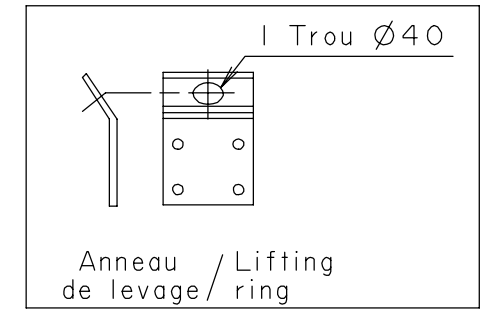
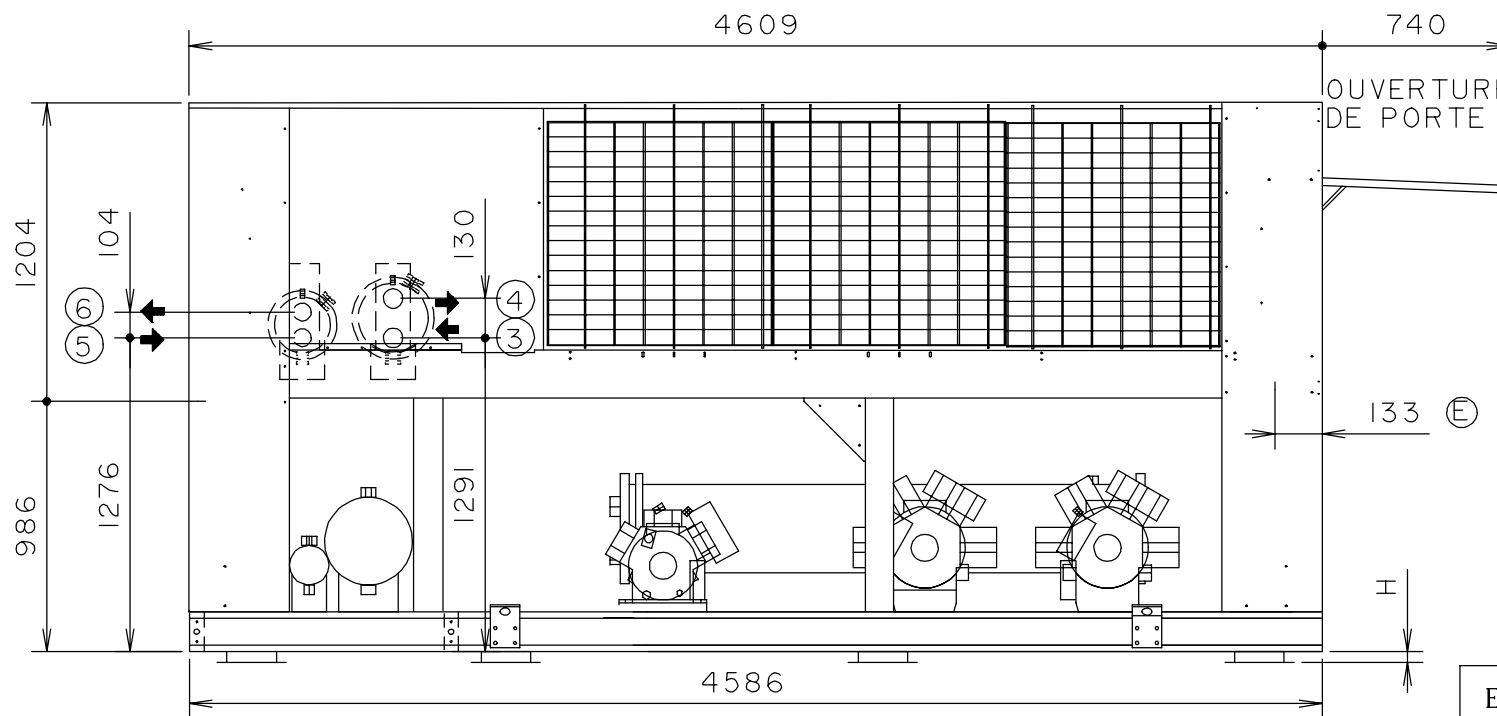
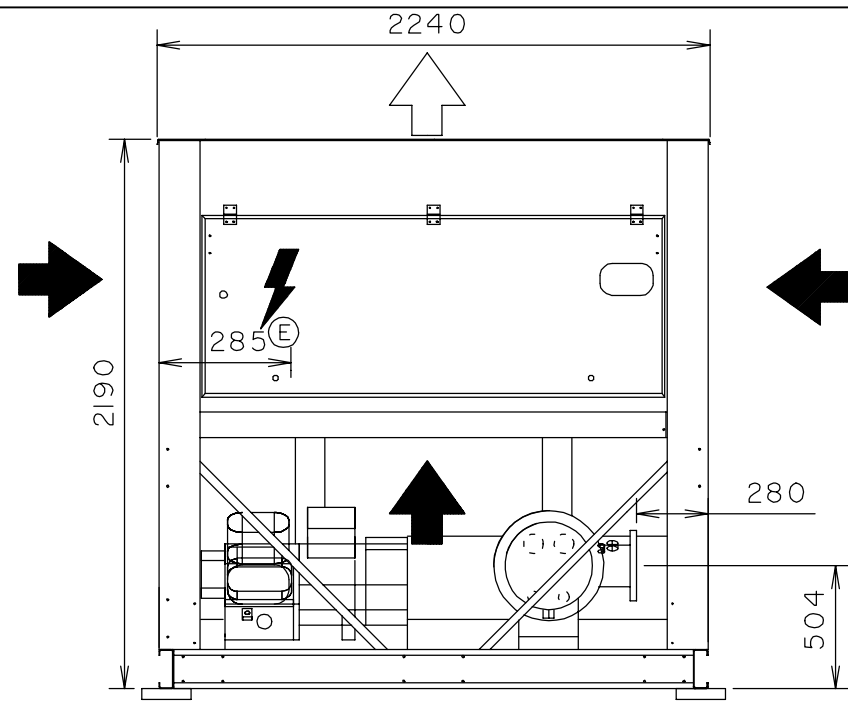

EN CAS DE RISQUE DE GEL L'APPAREIL DEVRA ETRE VIDANGE
 IN THE CASE OF RISK OF FREEZING THE UNIT MUST BE DRAINED

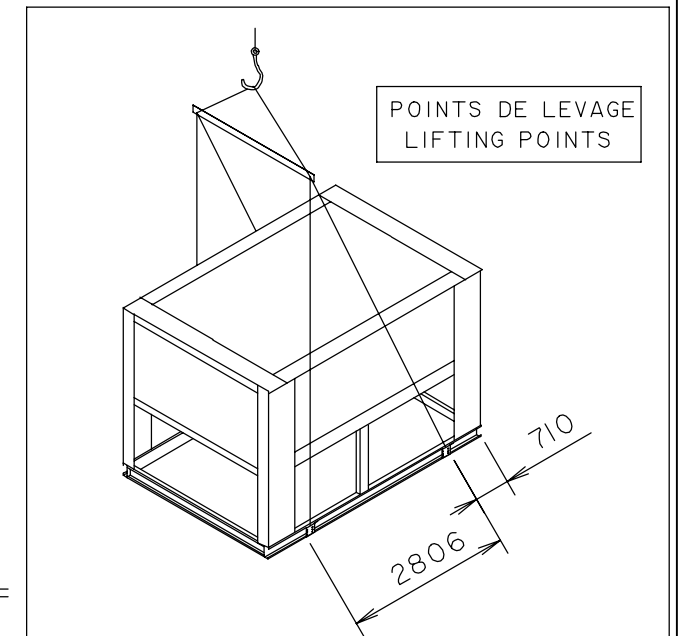

NOTA: Ne font pas partie des fournitures des groupes de refroidissement type CIATCOOLER LCT le cablage, le sectionneur fusible ou le disjoncteur entre le tableau électrique et le réseau (à prévoir impérativement par l'installateur) Prevoir un dégagement de 2m tout autour de l'unité pour l'entretien.
 -Le raccordement électrique (E) s'effectue par le dessous du tableau électrique.
 ➔ Aspiration air condenseur
 ⇨ Soufflage air condenseur
 -Aucun obstacle ne devra gêner le refoulement de l'air.

NOTES: Excluded from the supply of CIATCOOLER type LCT water chillers are isolators or fused switchgear and associated wiring between the electric panel and supply system (these must be provided by the installer)
 -Allow 2m of clearance all around the unit for maintenance.
 -the electrical connections (E) are made to the below of the electrical panel.
 ➔ Condenseur air inlet
 ⇨ Condenseur air discharge
 -No obstruction to the air discharge should be allowed.

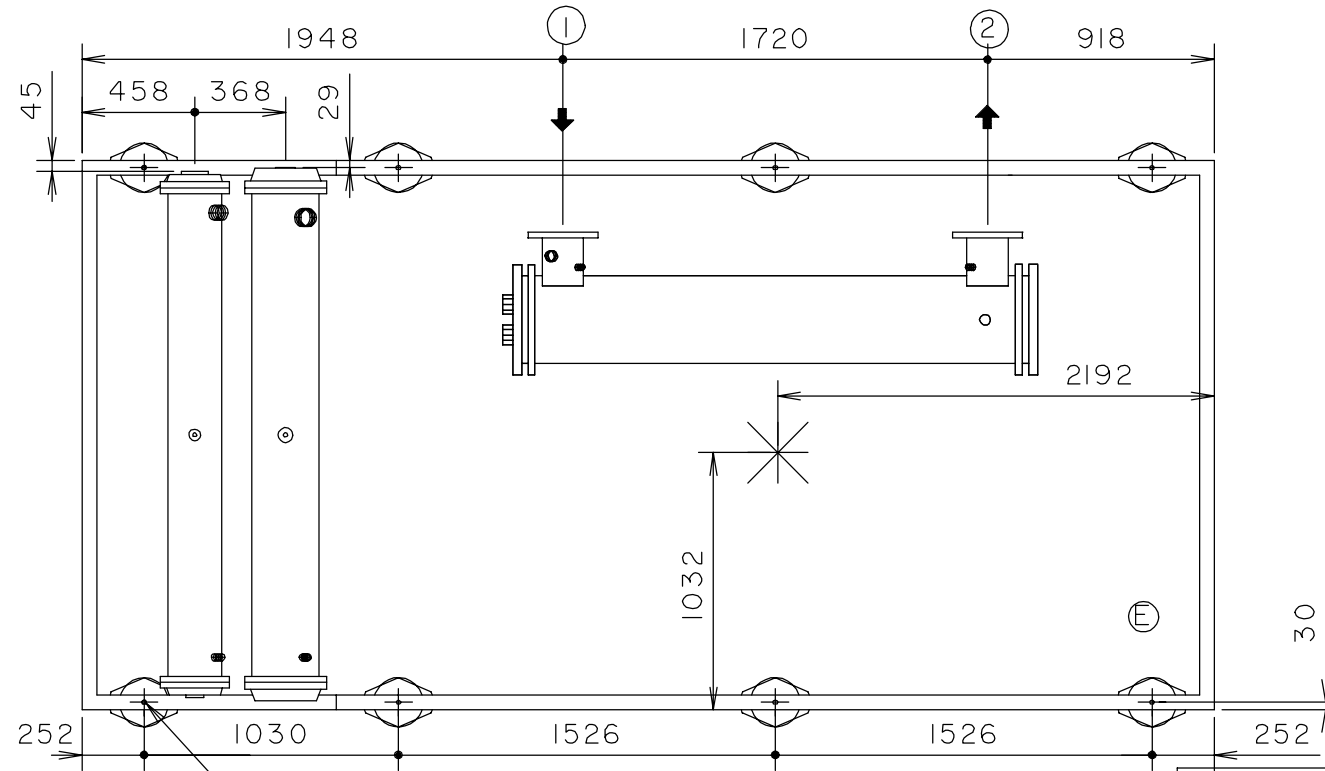

CIATCOOLER	Nbre de plots / Number of vibrationless suspension	Durete Shores	Diametre	A	H
1400	8	60	200	240	38

- ① Entree eau glatee bride PN16 DN 125 / Chilled water inlet flanged PN16 DN 125
- ② sortie eau glatee bride PN16 DN 125 / Chilled water outlet flanged PN16 DN 125
- ③ Entree eau chaude manchon 2"1/2 / Hot water inlet sleeves 2"1/2
- ④ Sortie eau chaude manchon 2"1/2 / Hot water outlet sleeves 2"1/2
- ⑤ Entree eau chaude manchon 2" / Hot water inlet sleeves 2"
- ⑥ Sortie eau chaude manchon 2" / Hot water outlet sleeves 2"

Circuit 1

Circuit 2

CIATCOOLER LC	Poids a vide en kg / Weight in kg	Poids en service en kg / Weight operational in kg
LCT 1400	4060	4210

✱ Axe de gravite / Axis of gravity

H.D	33	13.10.00	POSITION EVAPORATEUR STANDARD LC LCH
MODIFIE PAR	IND	N.ETUDE	DATE
APPAREIL OU UNITE			MATIERE:
LCT 1400 6H			
DESIGNATION			ECHELLE
ENCOMBREMENT/DIMENSION			TRAITEMENT
NUMERO DE COMMANDE:			FOLIO I/I
NOTE D'ETUDE:			REMPLE PAR:
VERIFIE PAR:			REMPLE:
DESSIN PAR:			FORMAT
EXCOFFON B.			NUMERO DE PLAN
DATE: 25/05/94			INDICE
A3			3976627 33

EN CAS DE RISQUE DE GEL L'APPAREIL DEVRA ETRE VIDANGE
 IN THE CASE OF RISK OF FREEZING THE UNIT MUST BE DRAINED

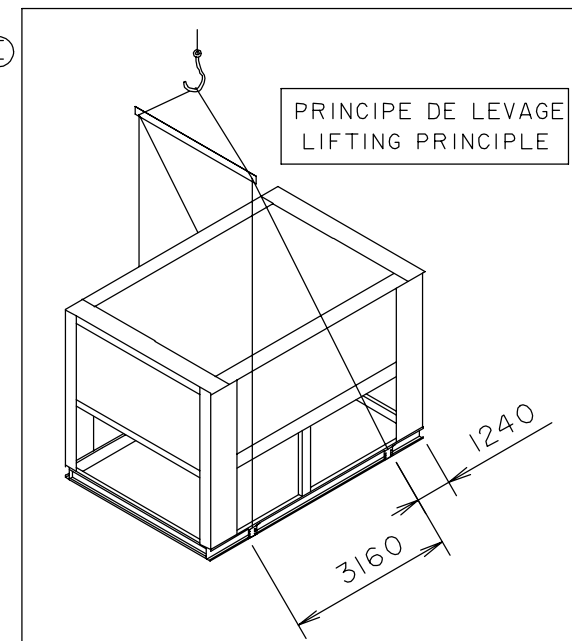
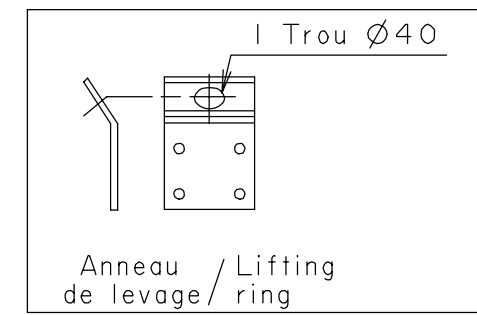
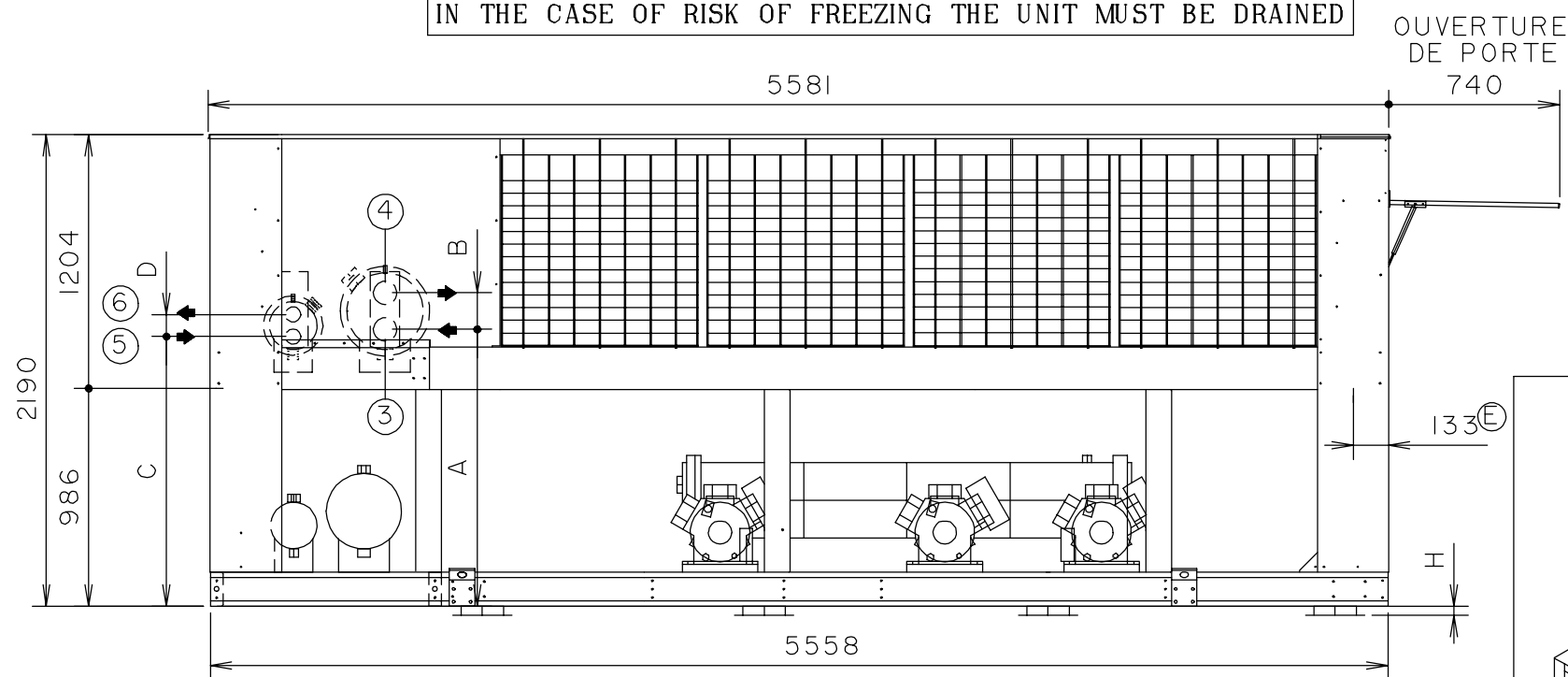
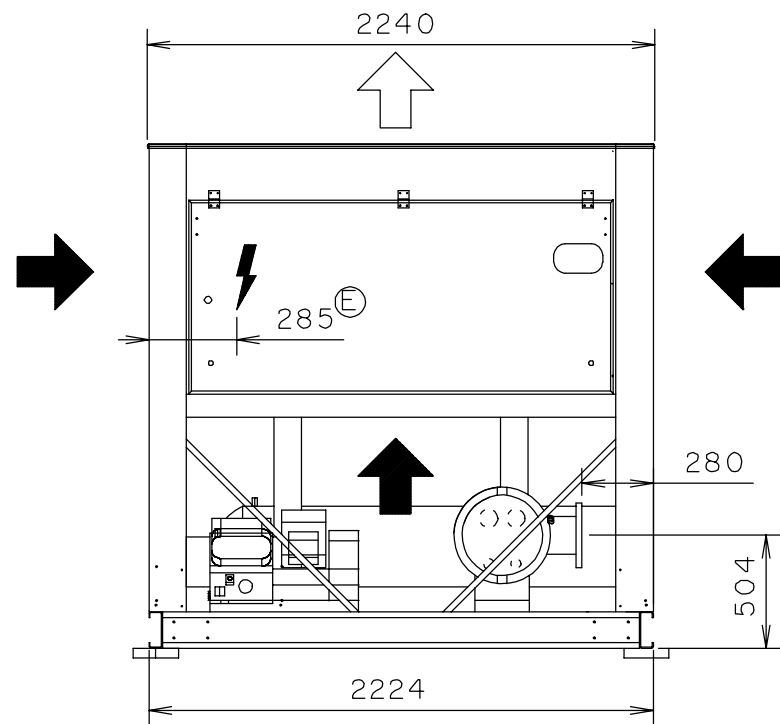

NOTA: Ne font pas partie des fournitures des groupes de refroidissement type CIATCOOLER LCT le cablage, le sectionneur fusible ou le disjoncteur entre le tableau électrique et le réseau (à prévoir impérativement par l'installateur) Prevoir un dégagement de 2m tout autour de l'unité pour l'entretien.
 -Le raccordement électrique ⑤ s'effectue par le dessous du tableau électrique.
 ➔ Aspiration air condenseur
 ⇨ Soufflage air condenseur
 -Aucun obstacle ne devra gêner le refoulement de l'air.

NOTES: Excluded from the supply of CIATCOOLER type LCT water chillers are isolators or fused switchgear and associated wiring between the electric panel and supply system (these must be provided by the installer)
 -Allow 2m of clearance all around the unit for maintenance.
 -the electrical connections ⑤ are made to the under side of the electrical panel.
 ➔ Condenseur air inlet
 ⇨ Condenseur air discharge
 -No obstruction to the air discharge should be allowed.

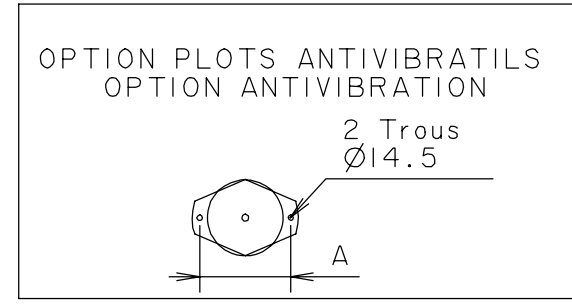
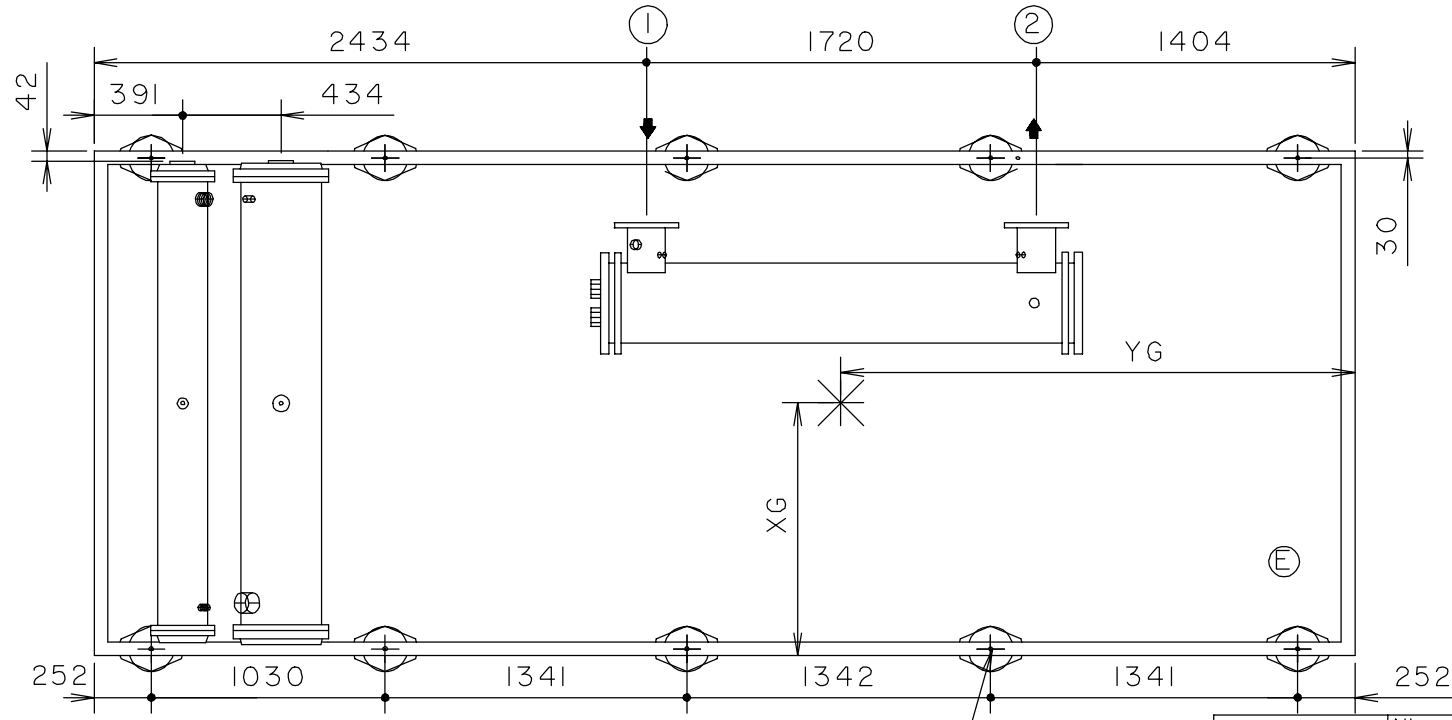

- ① Entrée eau glacée bride PN16 DN 125 / Chilled water inlet flanged PN16 DN 125
- ② sortie eau glacée bride PN16 DN 125 / Chilled water outlet flanged PN16 DN 125
- ③, ⑤ Entrée eau chaude / Hot water inlet
- ④, ⑥ Sortir eau chaude / Hot water outlet

LCT	XG	YG
1600	1024	2789
1803	1030	2818

Ø Manchon condenseur	3 et 4	5 et 6
1600	2"1/2	2"
1803	3"	

CIATCOOLER LC	Poids a vide en kg / Weight empty in kg	Poids en service en kg / Weight operational in kg
LCT 1600	4560	4710
LCT 1803	4880	5030

LCT	A	B	C	D
1600	1291	130	1276	104
1803	1311	172		

CIATCOOLER	Nbre de plots / Number of vibrationless suspension	Durete Shores	Diametre	A	H
1600	10	60	200	240	39
1803	10	60	200	240	39

* Axe de gravité / Axis of gravity

H.D	33	13.10.00	POSITION EVAPORATEUR STANDARD LC LCH
MODIFIE PAR	IND	N.ETUDE	DATE
		APPAREIL OU UNITE LCT 1600 ET 1803 8H	
DESIGNATION ENCOMBREMENT/DIMENSION		MATIERE:	
NUMERO DE COMMANDE:		ECHELLE TRAITEMENT	
NOTE D'ETUDE:		MASSE:	
VERIFIE PAR:		REMPLACE PAR:	
DESSIN PAR: EXCOFFON B.		REMPLACE:	
DATE: 19/05/94		FORMAT NUMERO DE PLAN INDICE	
A3		3976625 33	

EN CAS DE RISQUE DE GEL L'APPAREIL DEVRA ETRE VIDANGE
 IN THE CASE OF RISK OF FREEZING THE UNIT MUST BE DRAINED

OUVERTURE DE PORTE

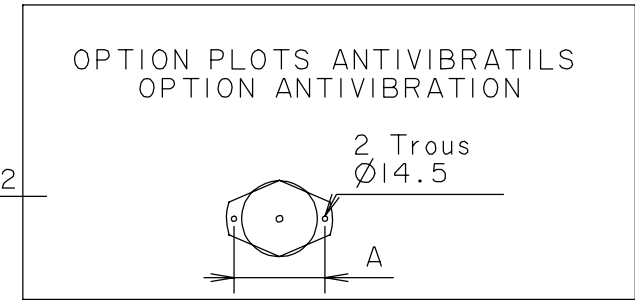
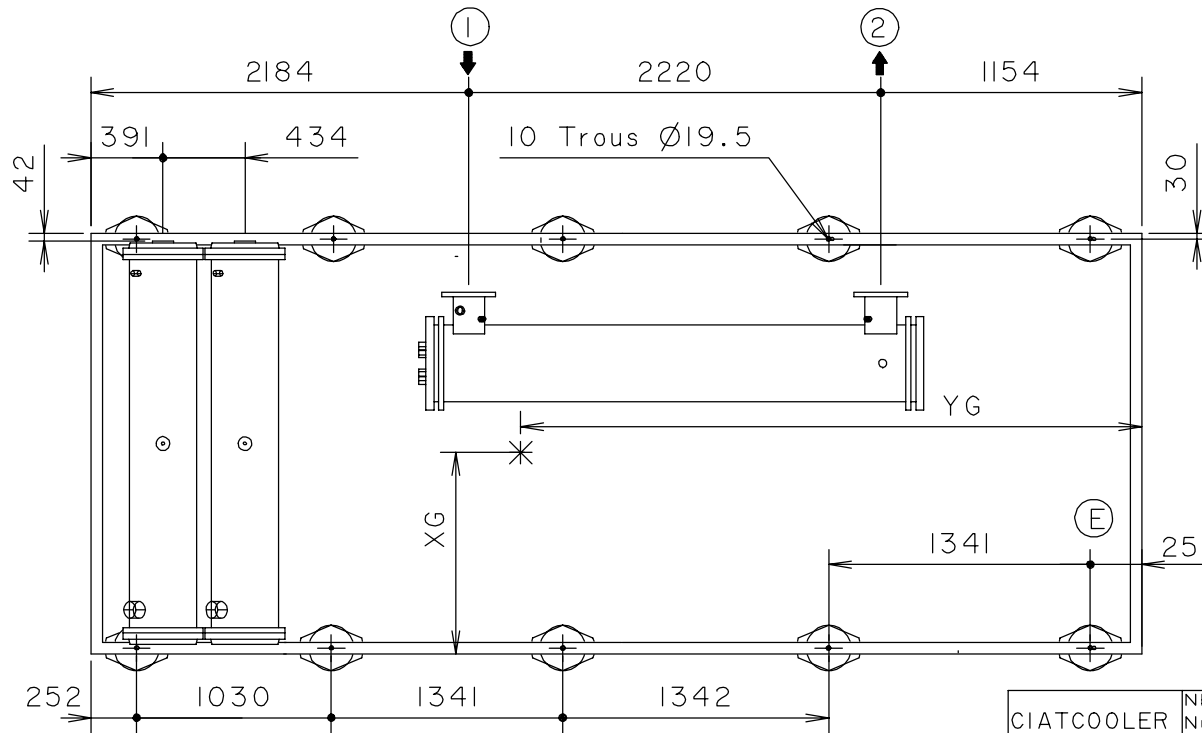
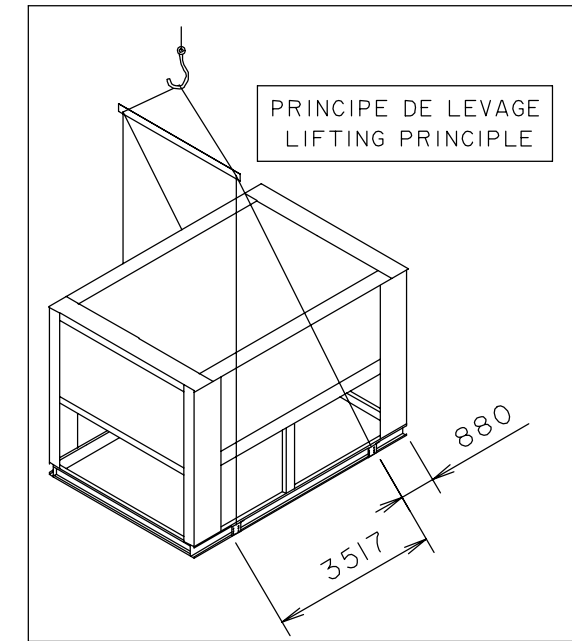
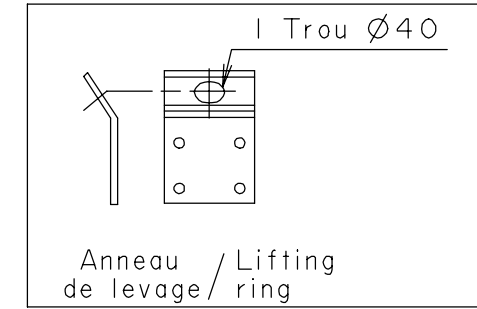
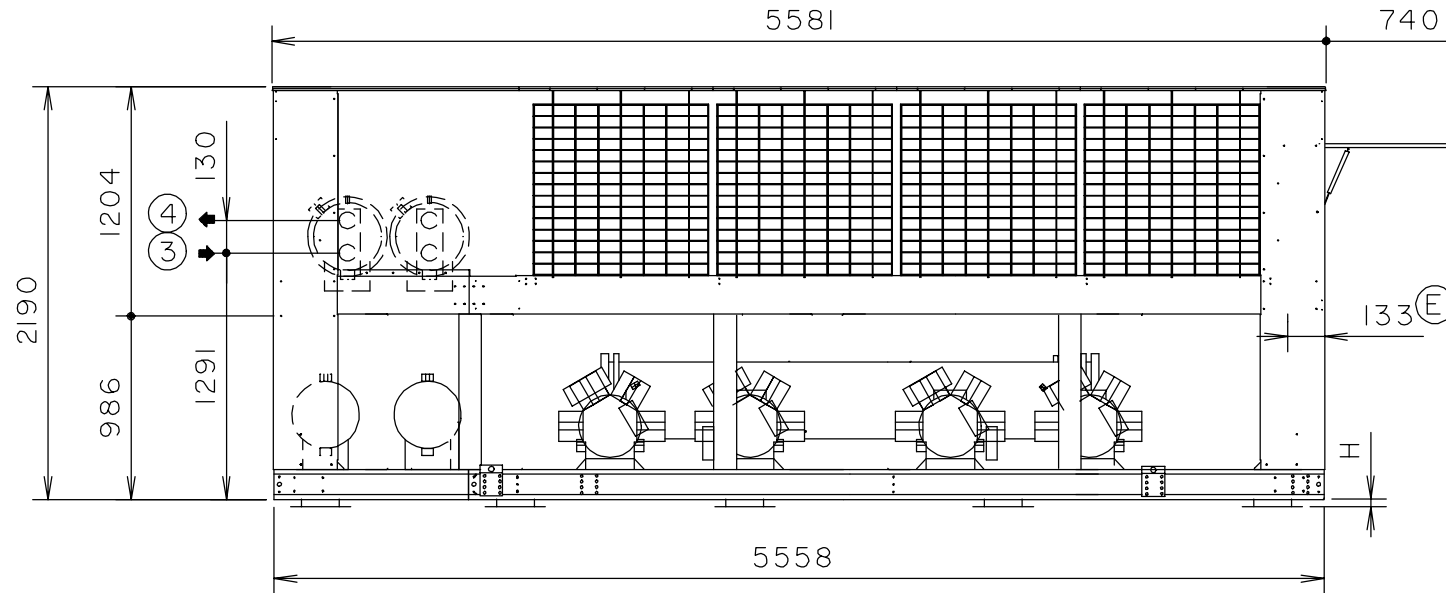
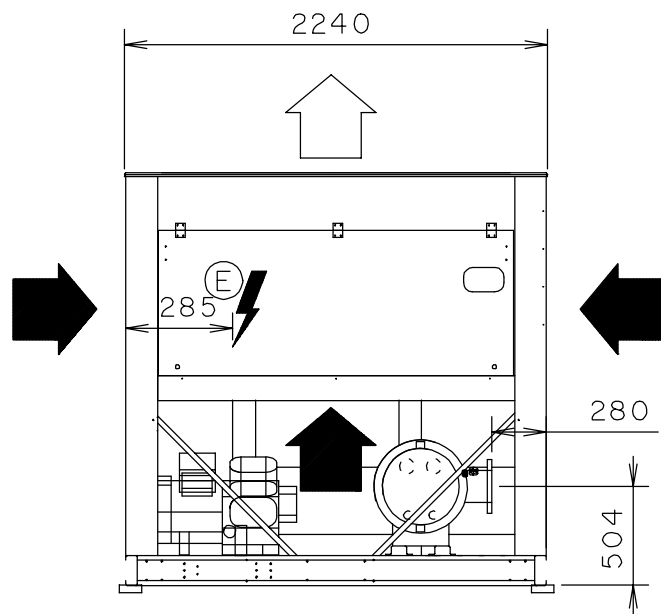

OPTION PLOTS ANTIVIBRATILS
 OPTION ANTIVIBRATION

CIATCOOLER	Nbre de plots Number of vibrationless suspension	Durete Shores	Diametre	A	H
1804	10	60	200	240	38
2000	10	60	200	240	38

* Axe de gravite / Axis of gravity

NOTA: Ne font pas partie des fournitures des groupes de refroidissement type CIATCOOLER LCT le cablage, le sectionneur fusible ou le disjoncteur entre le tableau electrique et le reseau (a prevoir imperativement par l'installateur) Prevoir un degagement de 2m tout autour de l'unité pour l'entretien.
 -Le raccordement électrique (E) s'effectue par le dessous du tableau électrique.
 ➡ Aspiration air condenseur
 ⇨ Soufflage air condenseur
 -Aucun obstacle ne devra gener le refoulement de l'air.

NOTES: Excluded from the supply of CIATCOOLER type LCT water chillers are isolators or fused switchgear and associated wiring between the electric panel and supply system (these must be provided by the installer)
 -Allow 2m of clearance all around the unit for maintenance.
 -the electrical connections (E) are made to the below of the electrical panel.
 ➡ Condenseur air inlet
 ⇨ Condenseur air discharge
 -No obstruction to the air discharge should be allowed.

- ① Entree eau glatee bride PN16 DN 125 / Chilled water inlet flanged PN16 DN 125
- ② sortie eau glatee bride PN16 DN 125 / Chilled water outlet flanged PN16 DN 125
- ③ Entree eau chaude manchon 2"1/2 / Hot water inlet sleeves 2"1/2
- ④ Sortie eau chaude manchon 2"1/2 / Hot water outlet sleeves 2"1/2

CIATCOOLER LC	Poids a vide en kg Weight empty in kg	Poids en service en kg Weight operational in kg
LCT 1804	5000	5300
LCT 2000	5300	5600

LCT	XG	YG
1804	1042	2836
2000	1004	2850

H.D	33	13.10.00	POSITION EVAPORATEUR STANDARD LC LCH
MODIFIE PAR	IND	N.ETUDE	DATE
		APPAREIL OU UNITE LCT 1804 ET 2000	
		DESIGNATION ENCOMBREMENT/DIMENSION	
		NUMERO DE COMMANDE:	
		NOTE D'ETUDE: DATE:	
		VERIFIE PAR: DATE:	
		DESSIN PAR: BE DATE:02/02/94	
		MATERIE:	
		ECHELLE	
		TRAITEMENT	
		MASSE:	
		REPLACE PAR:	
		REPLACE:	
		FORMAT	
		NUMERO DE PLAN	
		INDICE	
		A3 3976558 33	

EN CAS DE RISQUE DE GEL L'APPAREIL DEVRA ETRE VIDANGE
 IN THE CASE OF RISK OF FREEZING THE UNIT MUST BE DRAINED

OUVERTURE DE PORTE

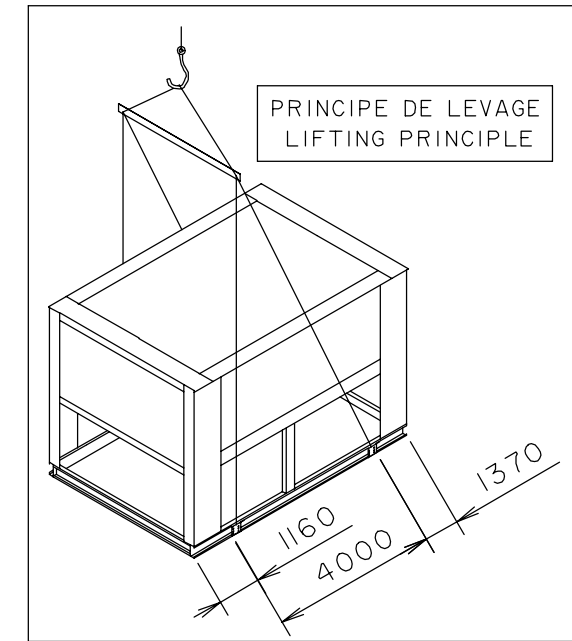
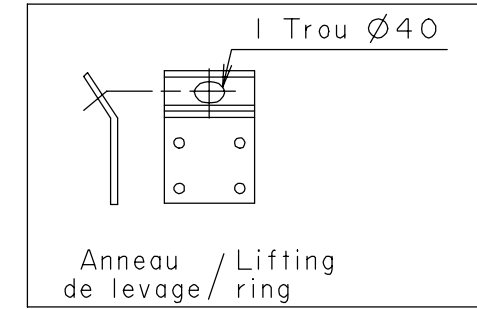
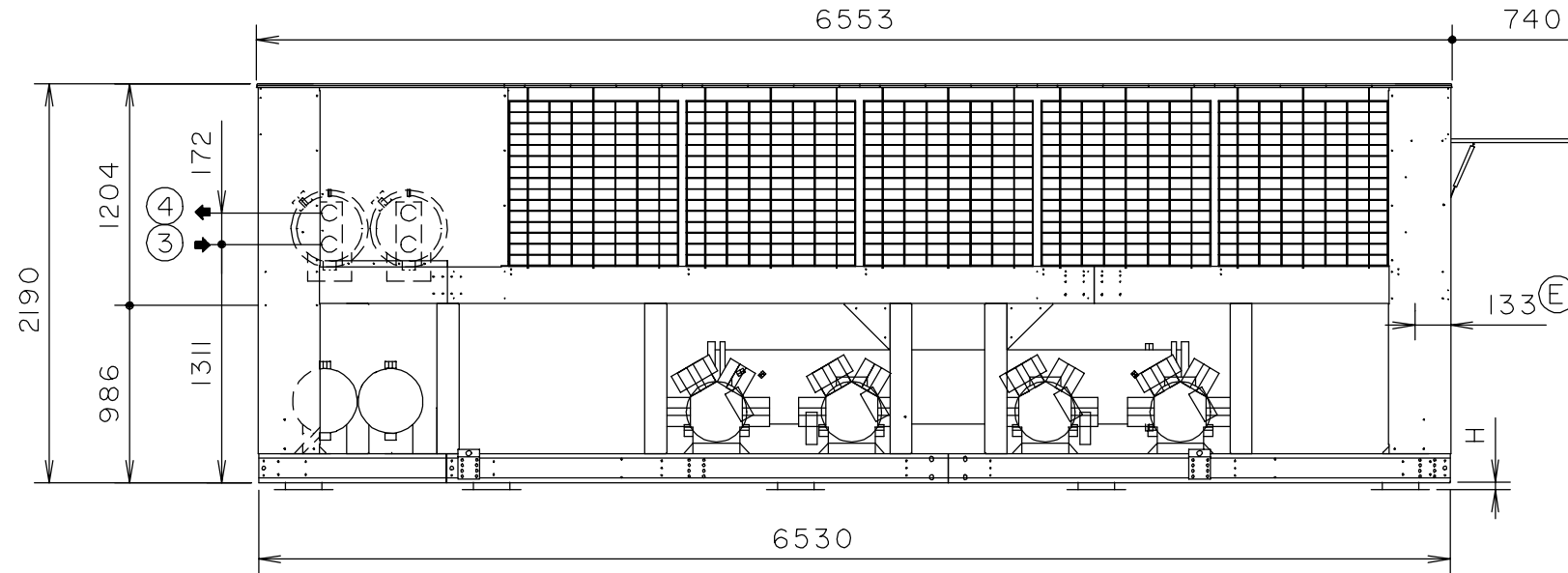
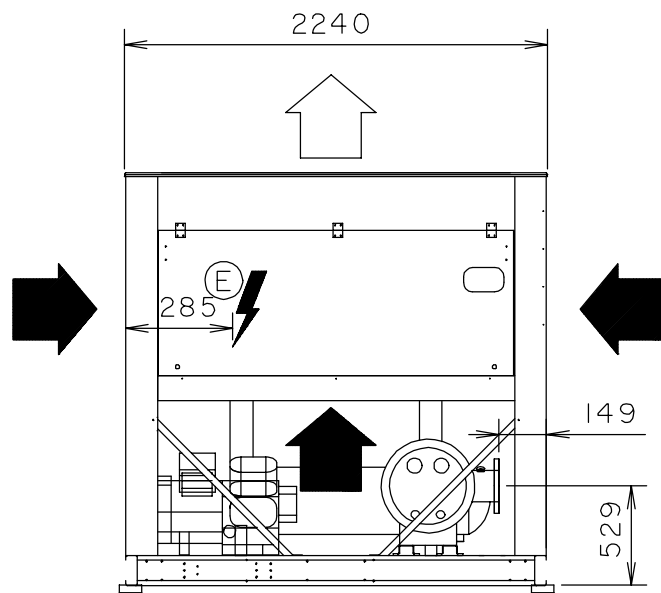

NOTA: Ne font pas partie des fournitures des groupes de refroidissement type CIATCOOLER LCT le cablage, le sectionneur fusible ou le disjoncteur entre le tableau électrique et le réseau (à prévoir impérativement par l'installateur) Prevoir un dégagement de 2m tout autour de l'unité pour l'entretien.
 -Le raccordement électrique (E) s'effectue par le dessous du tableau électrique.
 ➡ Aspiration air condenseur
 ⇨ Soufflage air condenseur
 -Aucun obstacle ne devra gêner le refoulement de l'air.

NOTES: Excluded from the supply of CIATCOOLER type LCT water chillers are isolators or fused switchgear and associated wiring between the electric panel and supply system (these must be provided by the installer)
 -Allow 2m of clearance all around the unit for maintenance.
 -the electrical connections (E) are made to the below of the electrical panel.
 ➡ Condenseur air inlet
 ⇨ Condenseur air discharge
 -No obstruction to the air discharge should be allowed.

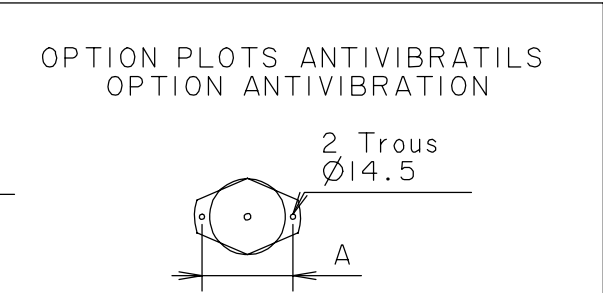
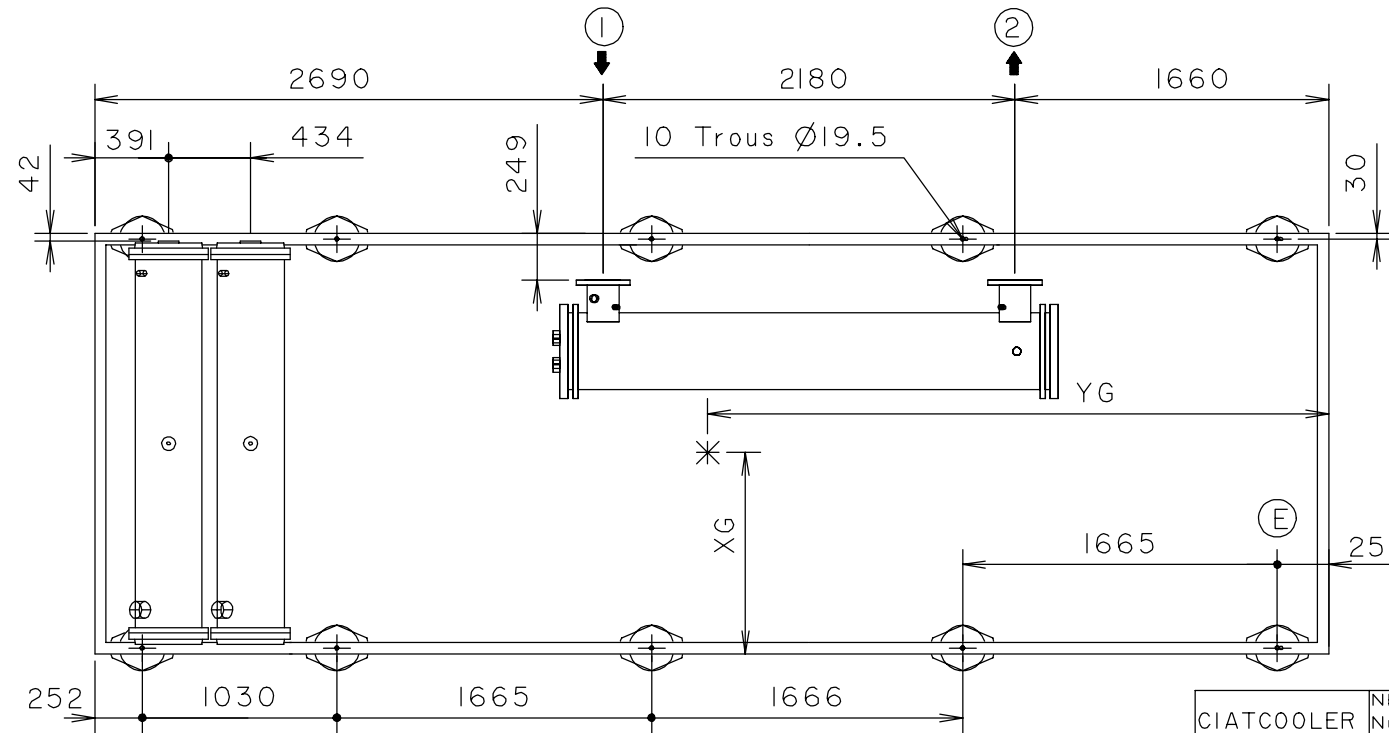

CIATCOOLER	Nbre de plots Number of vibrationless suspension	Durete Shores	Diametre	A	H
2200	10	60	200	240	38
2400	10	60	200	240	38

Axe de gravite / Axis of gravity

- ① Entree eau glatee bride PN16 DN 150 / Chilled water inlet flanged PN16 DN 150
- ② sortie eau glatee bride PN16 DN 150 / Chilled water outlet flanged PN16 DN 150
- ③ Entree eau chaude manchon 3" / Hot water inlet sleeves 3"
- ④ Sortie eau chaude manchon 3" / Hot water outlet sleeves 3"

CIATCOOLER LC	Poids a vide en kg Weight empty in kg	Poids en service en kg Weight operational in kg
LCT 2200	6100	6400
LCT 2400	6200	6500

LCT	XG	YG
2200	1045	3368
2400	1044	3354

H.D	34	06.10.00	POSITION EVAPORATEUR IDEM LC LCH
MODIFIE PAR	IND	N.ETUDE	DATE
		APPAREIL OU UNITE LCT 2200-2400	MATIERE:
		DESIGNATION ENCOMBREMENT/DIMENSION	ECHELLE TRAITEMENT
		NUMERO DE COMMANDE:	FOLIO MASSE:
		NOTE D'ETUDE: DATE:	REPLACE PAR:
		VERIFIE PAR: DATE:	REPLACE:
		DESSIN PAR: BE DATE: 18/01/94	FORMAT A3
		NUMERO DE PLAN 3976533	
		INDICE 34	