

cod. 923.390.1

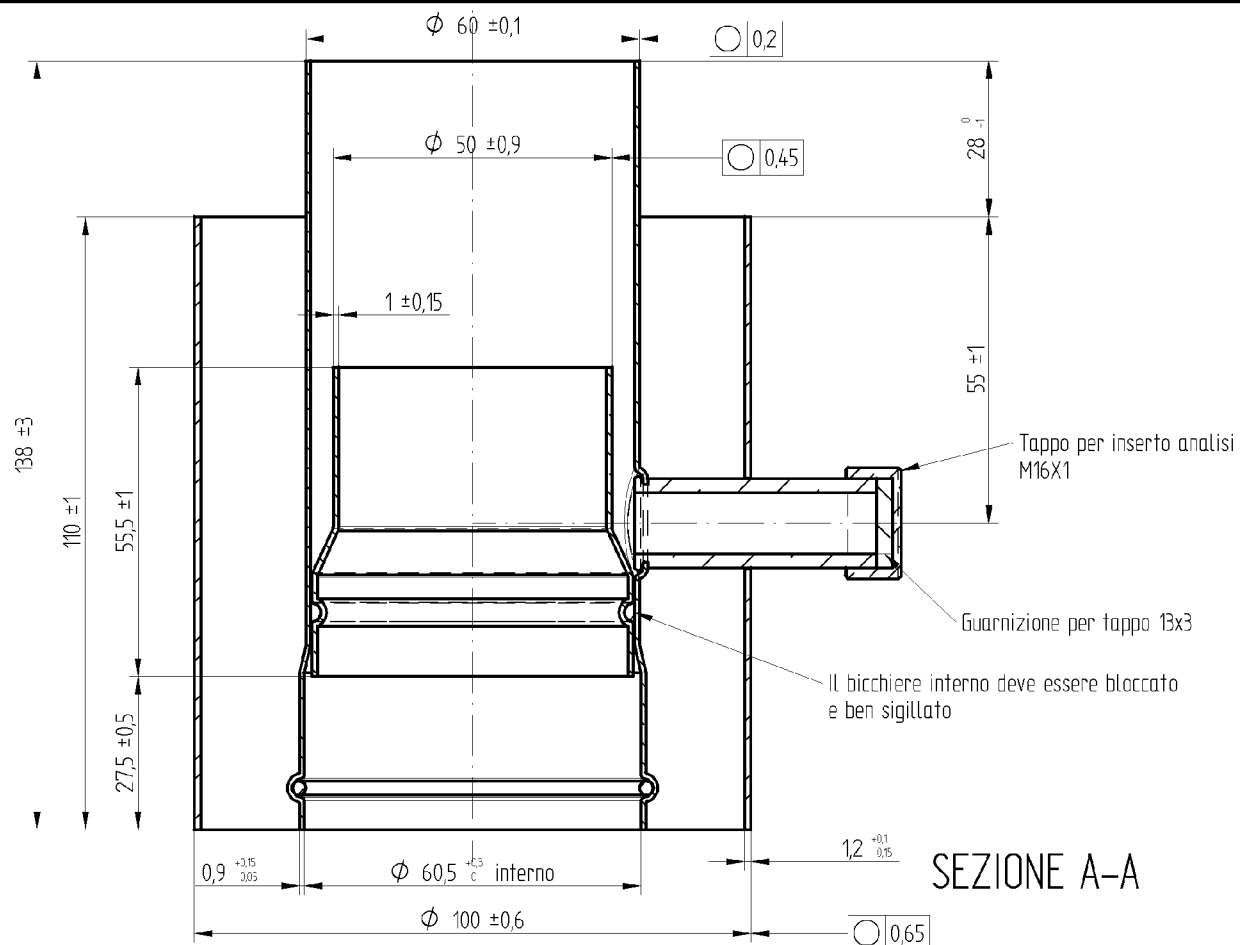

SEZIONE A-A

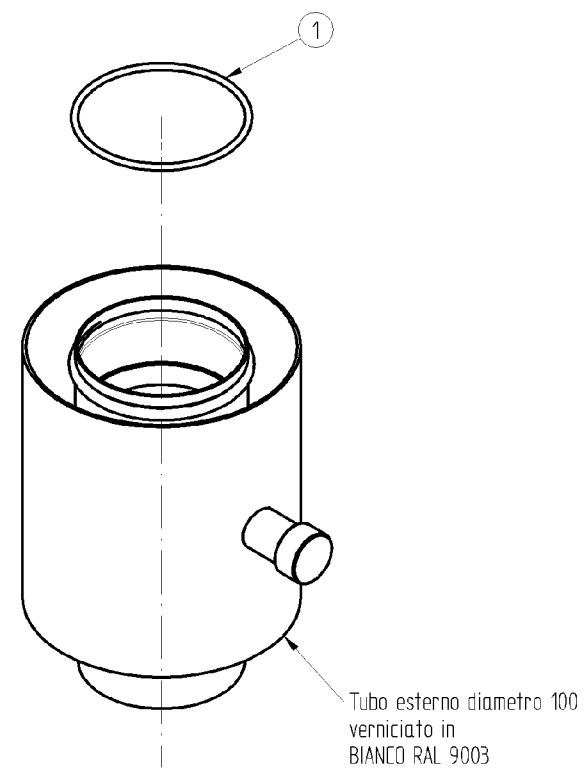
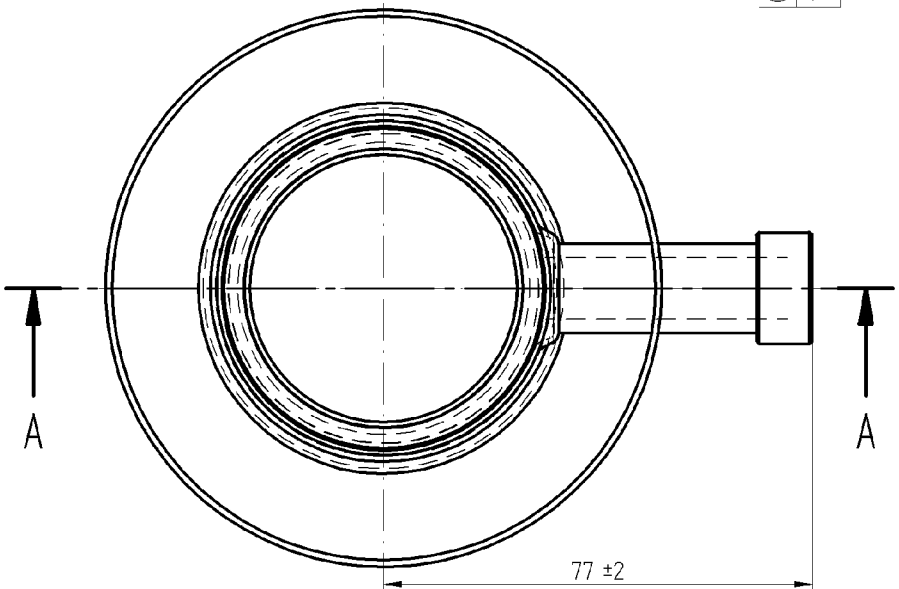

| | | | | | |
|---|--|----------------|-------------|-----------------|---------------------------|
| 1 ANELLO DI TENUTA OR 2,5X60 SILICONE | | 1 | 5404001.par | | |
| ASSIEME RACCOGLI CONDENSA 60/100 | | | | | |
| DENOMINAZIONE | | N° | Peso | design. | Stato |
| | | | | | Disegnato Sandro |
| | | | | | Data 18-11-2003 |
| | | | | | Controllato Scala |
| | | | | | 1 : 2 |
| | | | | | Sostituisce il |
| | | | | | Derivato dal 9 |
| | | | | | Specifica 8 |
| | | | | | MOD. 7 |
| | | | | | 6 |
| | | | | | 5 |
| | | | | | Errore Nessun riferimento |
| | | | | | 4 |
| MODIFICHE | | Firma | Richied. | Data | 3 |
| | | | | | 2 |
| | | | | | 1 |
| | | | | | 0 |
| BAXI S.p.A. | | Emittente DIRS | | CODICE | |
| | | Coimpiegante | | 56.7086. | |
| DISEGNO ESEGUITO CON CAD - NON CORREGGERE O MODIFICARE A MANO | | | | | |

