

# KCO LN

## 60, 90 & 120



English

Français

**1-way chilled water cassettes**

**Cassettes 1 voie à eau glacée**

**IOM KCO-N.5GBF**

Date : **April / Avril 2007**

Supersedes / Annule et remplace : **IOM KCO-N.4GBF**





**INSTALLATION INSTRUCTION**

NOTICE D'INSTALLATION

INSTALLATIONSHANDBUCH

ISTRUZIONI INSTALLAZIONE

INSTRUCCIONES DE INSTALACIÓN

English

Français

Deutsch

Italiano

Español

# CONTENTS

<b>GENERAL RECOMMENDATIONS .....</b>	<b>3</b>
SAFETY DIRECTIONS.....	3
WARNING3 .....	
<b>INSPECTION AND STORAGE .....</b>	<b>4</b>
<b>WARRANTY .....</b>	<b>4</b>
<b>DIMENSIONS .....</b>	<b>4</b>
<b>HANDLING .....</b>	<b>4</b>
NET WEIGHT .....	4
<b>ELECTRIC SPECIFICATIONS .....</b>	<b>5</b>
CURRENT ABSORBED BY THE MOTORS - 230 V / 1 PH / 50 HZ.....	5
ELECTRIC HEATING RESISTANCES - 230 V / 1 PH / 50 HZ .....	5
SPECIFICATIONS CABLES AND FUSES.....	5
<b>OPERATING LIMITS .....</b>	<b>6</b>
<b>INSTALLATION .....</b>	<b>6</b>
CLEARANCE .....	6
UNIT LOCATION .....	7
<b>HYDRAULIC CONNECTIONS .....</b>	<b>8</b>
COIL WATER CONNECTIONS.....	8
CONDENSATE DRAIN CONNECTION .....	9
INSTALLATION OF PIPE THERMOSTAT (CHANGE OVER) .....	10
TRM-FA AND TRM-VP .....	10
TAE20 AND AQUANET.....	10
NEW AIR INTAKE.....	11
<b>WIRING DIAGRAM AND LEGEND.....</b>	<b>11</b>
<b>ELECTRICAL CONNECTIONS.....</b>	<b>11</b>
REGULATION.....	12
ELECTRIC BATTERY .....	12
<b>COMMISSIONING .....</b>	<b>13</b>
PRE-START CHECK LIST.....	13
ELECTRICAL CHECK.....	13
HYDRAULIC CHECKS .....	13
VISUAL CHECK .....	13
<b>FINAL TASKS .....</b>	<b>13</b>
<b>IN CASE OF WARRANTY - MATERIAL RETURN PROCEDURE .....</b>	<b>14</b>
<b>ORDERING SERVICE AND SPARE PARTS ORDER .....</b>	<b>14</b>
<b>MAINTENANCE .....</b>	<b>15</b>
REGULAR MAINTENANCE .....	15
GENERAL INSPECTION .....	15
AIR FILTER .....	15
COIL15 .....	
CONDENSATE TRAY .....	16
FAN MOTOR ASSEMBLY .....	16
ELECTRICAL SECTION.....	18



## **POWER SUPPLY MUST BE SWITCHED OFF BEFORE STARTING TO WORK IN THE ELECTRIC CONTROL BOX**

### **GENERAL RECOMMENDATIONS**

The purpose of this Manual is to provide users with instructions for installing, commissioning, using and maintaining the **KCO LN** units.

It does not contain the complete description of all the maintenance operations guaranteeing the unit's long life and reliability. Only the services of a qualified technician can guarantee the unit's safe operation over a long service life.

Please read the following safety precautions very carefully before installing the unit.

#### **SAFETY DIRECTIONS**

Follow the safety rules in forces when you are working on your appliance.

The installation, commissioning and maintenance of these units should be performed by qualified personnel having a good knowledge of standards and local regulations, as well as experience of this type of equipment.

The unit should be handled using lifting and handling equipment appropriate to the unit's size and weight.

Any wiring produced on site must comply with the corresponding national electrical regulations.

Make sure that the power supply and its frequency are adapted to the required electric current of operation, taking into account specific conditions of the location and the current required for any other appliance connected with the same circuit.

The unit must be EARTHED to avoid any risks caused by insulation defects.

It is forbidden to start any work on the electrical components if water or high humidity is present on the installation site.

#### **WARNING**

Cutoff power supply before starting to work on the appliance.

When making the hydraulic connections, ensure that no impurities are introduced into the pipe work.

**The manufacturer declines any responsibility and the warranty becomes void if these instructions are not respected.**

If you meet a problem, please call the Technical Department of your area.

If possible, assemble the compulsory or optional accessories before placing the appliance on its final location. (see instructions provided with each accessory).

In order to become fully familiar with the appliance, we suggest to read also our Technical Instructions.

-The informations contained in these Instructions are subject to modification without advance notice.

## INSPECTION AND STORAGE

At the time of receiving the equipment carefully cross check all the elements against the shipping documents in order to ensure that all the crates and boxes have been received. Inspect all the units for any visible or hidden damage.

**THE ADDRESSEE HAS TOTAL RESPONSIBILITY FOR INSPECTING THE CONDITION OF THE EQUIPMENT AT THE TIME OF RECEPTION. ACCORDINGLY, THE MERCHANDISE SHOULD BE UNPACKED IN THE PRESENCE OF A REPRESENTATIVE FROM THE TRANSPORT COMPANY RESPONSIBLE FOR SHIPPING THE GOODS.**

**In the event of damage or missing items, detailed acceptance reservations should be notified in writing to the transport company by recording the damage observed and the number of packages delivered on the goods receipt note.**

**These comments should then be confirmed to the shipping company within a period of 3 working days by registered letter.**

**STORE THE EQUIPMENT IN A CLEAN, DRY AREA, AWAY FROM ANY RISK OF IMPACTS AND TEMPERATURE VARIATIONS.**

## WARRANTY

The appliances are delivered fully assembled, factory tested and ready to operate.

Any modification to the units without the manufacturer's prior approval, shall automatically render the warranty null and void.

The following conditions must be respected in order to maintain the validity of the warranty:

- Commissioning shall be performed by specialised technicians from technical services approved by the manufacturer.
- Maintenance shall be performed by technicians trained for this purpose.
- Only Original Equipment spare parts shall be used.
- All the operations listed in the present manual shall be performed within the prescribed SCHEDULE.



**THE WARRANTY SHALL BE NULL AND VOID IN THE EVENT OF NON-COMPLIANCE WITH ANY OF THE ABOVE CONDITIONS.**

## DIMENSIONS

**SEE APPENDIX**

## HANDLING

The apparatus should be handled with care as any potential impacts might damage the balance of the fan/motor assembly. Take care not to press on the air distribution outlets as this might affect air distribution. Use of the mounting pads is recommended for handling the apparatus. **Do not lift the apparatus by the condensate drainage outlet or the water connection points.** For positioning the apparatus during installation, we recommend the use of a forklift truck. Care must be taken to protect the fascia against any risk of possible impacts or scratching.

### NET WEIGHT

Models		<b>60</b>	<b>90</b>	<b>120</b>
weight	Kg			
	without height adjuster	23	33	48
	with height adjuster	26	37	53

## ELECTRIC SPECIFICATIONS

### CURRENT ABSORBED BY THE MOTORS - 230 V / 1 PH / 50 HZ

		60					
		V6	V5	V4	V3	V2	V1
Power absorbed	W	53	44	31	27	21	15
Current absorbed	A	0.23	0.19	0.14	0.12	0.09	0.07
Speed	Tr/min	1224	960	788	689	554	471

		90					
		V6	V5	V4	V3	V2	V1
Power absorbed	W	1108	75	59	50	38	29
Current absorbed	A	0.47	0.33	0.26	0.22	0.17	0.13
Speed	Tr/min	1293	1139	980	864	718	578

		120					
		V6	V5	V4	V3	V2	V1
Power absorbed	W	105	76	60	50	38	29
Current absorbed	A	0.47	0.34	0.26	0.22	0.17	0.13
Speed	Tr/min	1204	892	755	636	518	422



Factory wired

Refer to the appendix for information on changing the wiring on site.

### ELECTRIC HEATING RESISTANCES - 230 V / 1 PH / 50 HZ

	POWER W		
	1R	2R	3R
60	400	800 (2x400)	1200 (3x400)
90	1000	2000 (2x1000)	/
120	1500	2500 (1500+1000)	/

Note: Units with integrated electric heating are equipped with automatic and manual reset temperature safety devices.

In certain circumstances, and after a fan malfunction, the manual thermostatic safety device may trip out. In the case, it should be reset after cutting off the mains power supply to the system (see § ELECTRIC BATTERY).

### SPECIFICATIONS CABLES AND FUSES

		Cable section**	Fuse rating type gG
60	Without heating	3G1.5	1A
	Power heating 1R	3G1.5	4A
	Power heating 2R	3G1.5	6A
	Power heating 3R	3G1.5	8A
90	Without heating	3G1.5	2A
	Power heating 1R	3G1.5	6A
	Power heating 2R	3G1.5	12A
120	Without heating	3G1.5	2A
	Power heating 1R	3G1.5	10A
	Power heating 2R	3G2.5	16A

### IMPORTANT

\*\* These datas are given for guidance only. They must be checked at commissioning according to prevailing standards. They depend on the installation and the cables used.

## OPERATING LIMITS

<b>Water pipes</b>	Maximum operating pressure	10 bar
	Minimum inlet temperature	+ 6 °C
	Maximum inlet temperature	+ 90 °C
<b>Premises air temperature</b>	Minimum temperature	5 °C
	Maximum temperature	32 °C
	Relative humidity - Minimum	15%
	Relative humidity - Maximum	70%
<b>Supply voltage</b>	230 V ± 10 % / 1 ph / 50 Hz	

## INSTALLATION



The unit is not designed to withstand weights or stresses from adjacent equipment, pipe work or constructions. Any foreign weight or stress on the unit structure could lead to a malfunction or a collapse with dangerous consequences for personnel and property. In such an event, the warranty shall be null and void.

The apparatus is intended to be installed ideally in the place of a suspended ceiling tile in a ceiling with a minimum height of 2.5 metres and of 4 metres maximum

Install the apparatus in a position that allows for easier condensate drainage.

Ensure that sufficient free clearance is left around the apparatus for maintenance access (see chart below for minimum free clearance on the maintenance access side).

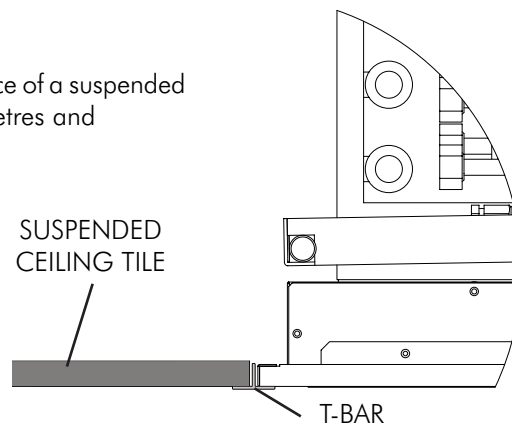

## CLEARANCE

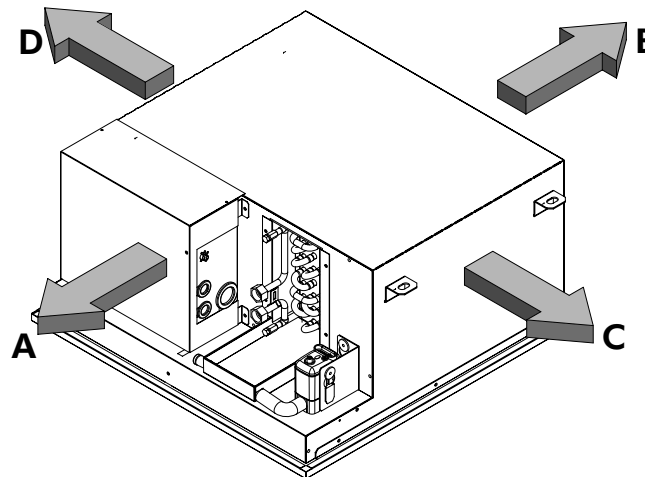

	60	90	120
A	200	500	800
B			
C	300	300	300
D			



**ENSURE THAT THERE IS SUFFICIENT FREE SPACE BETWEEN THE SUSPENDED CEILING AND THE SOLID CEILING FOR THE UNIT TO BE LOCATED.**



## UNIT LOCATION



The unit base shall be arranged as indicated in the manual. There could be a risk of personal injury or damage to property in the event of the unit being incorrectly supported.

The apparatus must be positioned ideally at the edge of the room with the air return grille situated against a wall and air being distributed along the length of the room. In order to guarantee optimal air distribution (COANDA), avoid locating the apparatus in premises with exposed beams or light fittings that would form obstacles to even distribution.

Furthermore, locating the apparatus in the centre of a room is not recommended.

1. It must be high enough to permit good drainage of defrost water with syphon
2. All electrical and ductwork connections to the unit must be made via flexible connections to prevent transmission of vibration.
3. In addition to the service clearances noted on the dimension sheet it is essential that provision is made for adequate and safe service access.
4. Do not install the unit in a machinery room or a kitchen where vapours or oil mist could pass through the unit.
5. Do not install the unit in a laundry or in very damp areas (bathroom, sauna, etc.).

The unit is designed to be suspended on threaded rods or screw-spikes to be supplied by the installer. The mounting lugs with slot type holes are fitted to the upper part of the unit.

Attach the 4 threaded rods or spike-screws to the solid ceiling in accordance with the diagram opposite. Place 4 nuts and washers on each threaded rod.

Lift up the unit and slide the 4 threaded rods through the mounting lugs slots (the unit casing must not touch the ceiling).

Attach the unit with 4 further firmly tightened washers, nuts and lock nuts. We recommend fitting rubber blocks to prevent any risks of vibration be transmitted to the structure.

Lock the unit in its final location and **level it off with a spirit level** in order to guarantee correct operation and condensate evacuation.

The unit must be installed so that the water drains towards the evacuation connection.

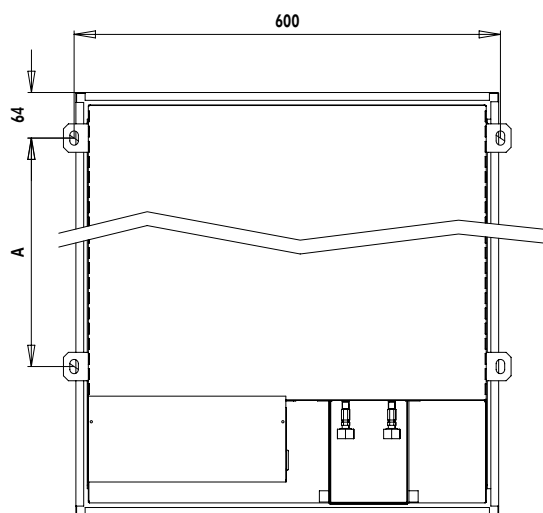

	A
60	320
90	620
120	920

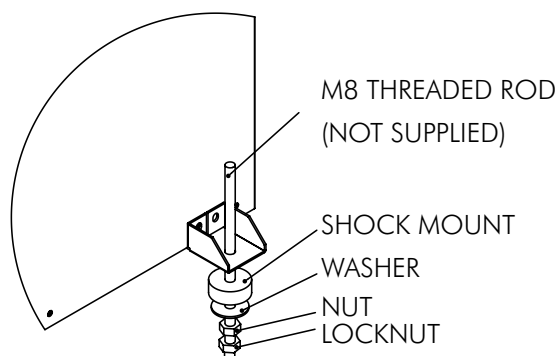

## HYDRAULIC CONNECTIONS

## SEE APPENDIX

## COIL WATER CONNECTIONS



The supply water (2-pipe and 4-pipe coils) should pass through the bottom header.

The coils are equipped with  $\frac{1}{2}$ » female gas type connectors as well as an air bleed and drain valve. To bleed air from the coil, use the bleed valve located on the upper part of the top collector. The coil (s) must be bled if the apparatus is taken out of service in buildings subject to negative ambient temperatures, as the formation of ice might break the batteries.

To drain the coil, use the drain valves situated on the lower part of the bottom collector.

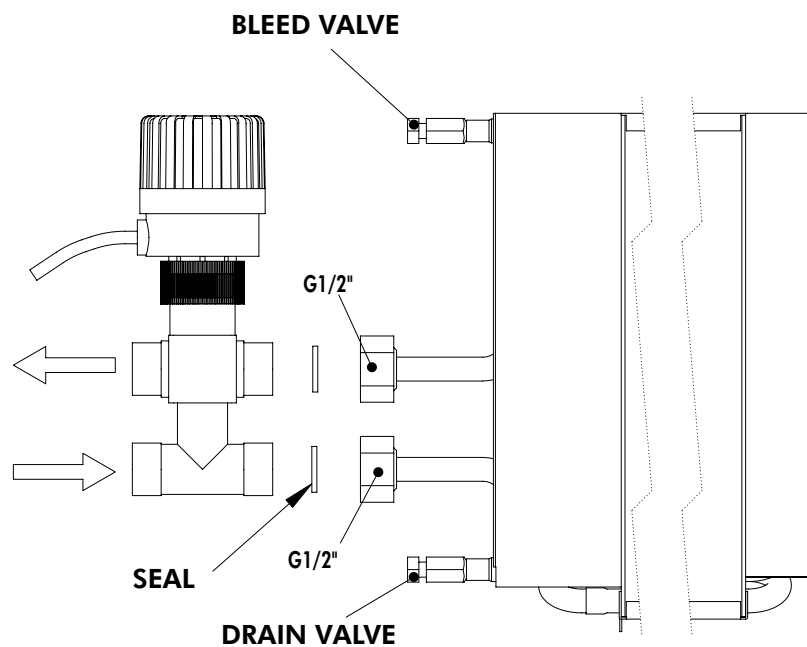

Stainless steel braided hose or equivalent is recommended for coil connections. Take care not to over-tighten the water connections. Over-tightening can lead to excessive strains on the materials in the event of major temperature variations.



To avoid damaging the coil, tighten the water pipe connectors on each header using a counter-wrench.

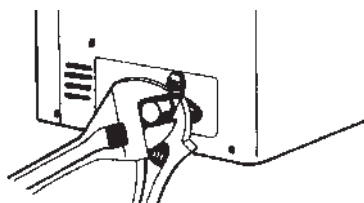

## CONDENSATE DRAIN CONNECTION

The units are equipped with a corrosion protected, painted, sloping, non water-retaining tray. Condensed water is drained via the 16 mm diameter connecting teats located either side of the main tray. In all cases, we recommend the use of a transparent flexible or rigid pipe. Take care to create a uniform slope of at least 2 cm/m and to provide for a siphon of at least 5 cm to prevent disagreeable odours working back through the system.

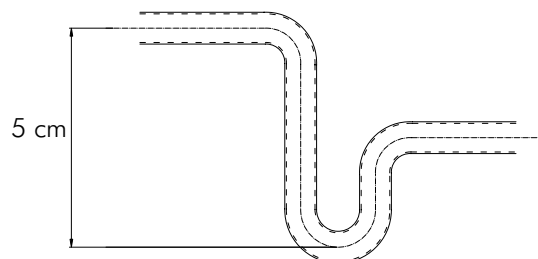
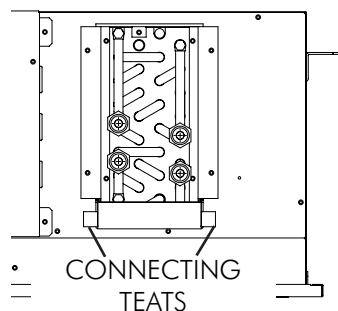

In the case of drainage via a lift pump, the connection is to be made between the pump outlet hose and the wastewater pipe by using a clear flexible pipe, inner diameter 6 mm (**not supplied**).

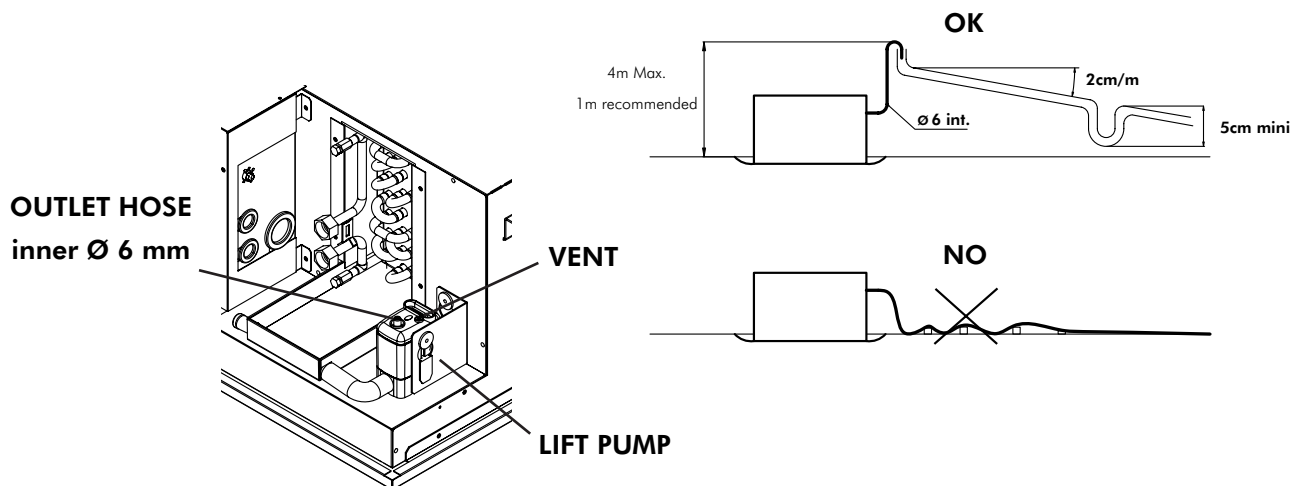

Warning: Care should be taken to ensure that the pipe is neither pinched nor in contact with the unit, as this could result in poor drainage or vibrations.

In addition, we recommend that the condensates drainage hose be insulated with insulating material such as polyurethane or neoprene, 5 mm thick.

Pump characteristics:

- Power input: 10W.
- Maximum output: 6.8l/h for a lift height of 1m over a 5m length.
- Maximum lift height: 4m



Ensure that the condensed water will run freely out of the tray. The latter must be connected to the main drainage pipe.

Check that there is no uphill section in the pipe run which might prevent condensate evacuation.

All foreign bodies must be removed from the condensate tray.

## INSTALLATION OF PIPE THERMOSTAT (CHANGE OVER)

### TRM-FA AND TRM-VP



The pipe thermostat (change-over switch) supplied is to be mounted on the water supply pipe.  
Crimp the 6.35 F fast-on clips with their insulator bushes (supplied) on the wires of this thermostat.

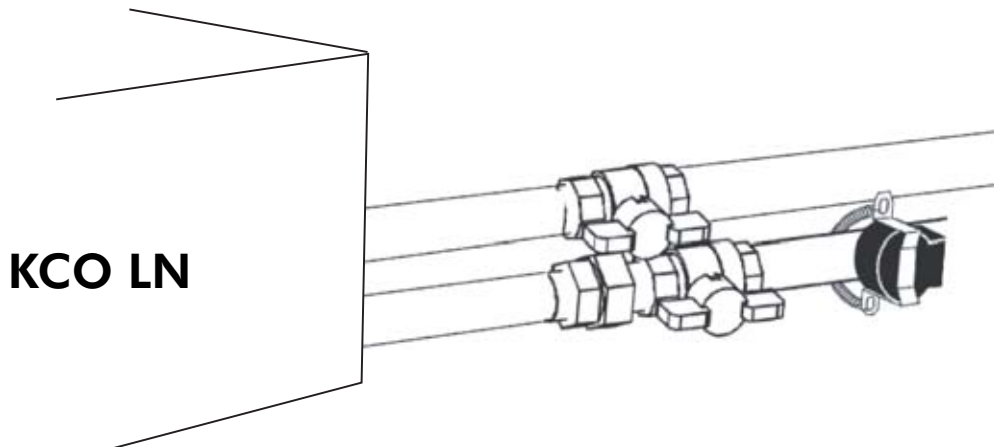

### OPERATING TEMPERATURE RANGE

Opening	$30 \pm 4^{\circ} \text{C}$
Closing	$15 \pm 4^{\circ} \text{C}$

### TAE20 AND AQUANET



The tube thermostat (change over) supplied is to be fitted to the water inlet tube.

- Before assembling the change over sensor, coat the tube with heat conducting paste to guarantee that the real temperature is recorded.
- The 9 and 10 change over sensor inputs are connected to the mains power supply. If it is necessary to extend the sensor wires, ensure that wires appropriate for this voltage are used.

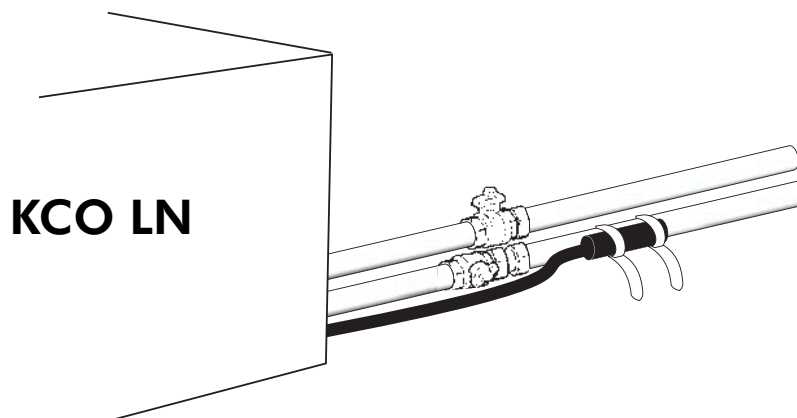

**SEE APPENDIX**

## NEW AIR INTAKE

### SEE APPENDIX

The units are equipped with a 100 mm or 125 mm cut-out for fitting a new air intake.

In install a new air intake, use metal shears to remove the cut-out and then use a cutter to cut and remove the insulation. Take care not to leave any insulation particles inside.

A regulation module can also be fitted to the apparatus.

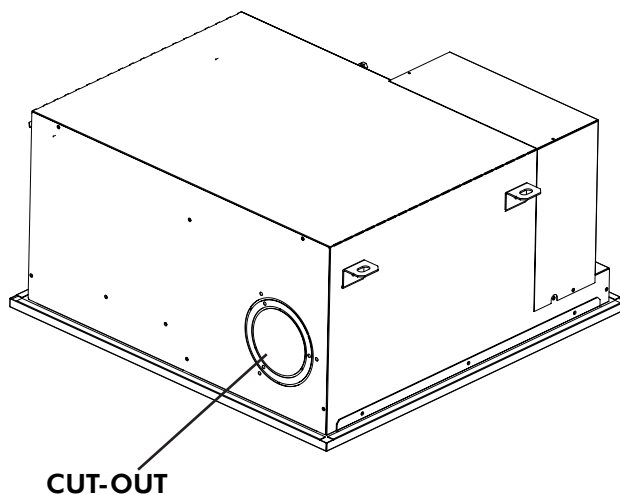

## WIRING DIAGRAM AND LEGEND

### SEE APPENDIX

## ELECTRICAL CONNECTIONS

### WARNING



**BEFORE CARRYING OUT ANY WORK ON THE EQUIPMENT, MAKE SURE THAT THE ELECTRICAL POWER SUPPLY IS DISCONNECTED AND THAT THERE IS NO POSSIBILITY OF THE UNIT BEING STARTED INADVERTENTLY. NON-COMPLIANCE WITH THE ABOVE INSTRUCTIONS CAN LEAD TO INJURY OR DEATH BY ELECTROCUTION.**

The electrical installation must be performed by a fully qualified electrician, and in accordance with local electrical standards and the wiring diagram corresponding to the unit model.

Any modification performed without our prior authorisation may result in the unit's warranty being declared null and void.

The power supply cable section must be sufficient to provide the appropriate voltage to the unit's power supply terminals, both at start-up and under full load operating conditions.

The power supply cable shall be selected in accordance with the following criteria:

1. Power supply cable length.
2. Maximum unit starting current draw – the cables shall supply the appropriate voltage to the unit terminals for starting.
3. Power supply cables' installation mode.
4. Cables' capacity to transport the total system current draw.

Short circuit protection shall be provided. This protection shall comprise fuses or circuit breakers with high breaking capacity, mounted on the distribution board.

A device to disconnect all the power conductors with an approved minimum opening distance must be included in the mains power supply according to best installation practices.

The units are intended to be connected to a 230 V  $\pm$  10% / 1 phase / 50 Hz + Earth network. Before starting any electrical connection, check that the fan motor corresponds to the electrical supply voltage. Each apparatus comprises a terminal block situated on the hydraulic side. Ensure that all power to the apparatus is disconnected before unscrewing the terminal block cover to gain access to the connection terminals.

The units has 6 speed settings, 3 of which are factory pre-wired on the transformer. To alter the wiring, move the wires connected to terminals 1, 2, 3, 4, 5 or 6 on the transformer.



#### **THE UNIT MUST BE EARTHED.**

The manufacturer and their representatives decline all responsibility for any accidents caused by inadequate or non-existent earthing of the installation.

#### **REGULATION**

As standard, the units are supplied without regulation equipment.

However, certain control devices (fan speed selector, remote thermostat, etc.) can be supplied according to request.

In all events, these regulation devices are only intended to control **a single unit**.



**DO NOT CONNECT SEVERAL UNITS TO A SINGLE VENTILATION SPEED SELECTOR OR REGULATION THERMOSTAT WITHOUT USING AUXILIARY RELAYS.**

**CHECK THAT THE CURRENT ABSORBED BY THE MOTORS IS COMPATIBLE WITH THE CUT-OUT CAPACITY OF THE CONTROL DEVICE CONTACTS.**

#### **ELECTRIC BATTERY**

In the case of units equipped with electric heating resistances, the latter must be linked to fan operation. Any fan stoppage must cut the power supply to the electric resistances. The units are equipped with automatic and reset safety thermostats as protection against motor overheating or mechanical and electronic problems. In the case of the manual thermostat, it is accessible for resetting in the suspended ceiling by way of a side access opening at the level of the electrical box. Before resetting this safety device, the cause of its tripping should be identified (low or no airflow caused by a clogged filter, servo-control problem, regulation problem...).

**RESETTING**

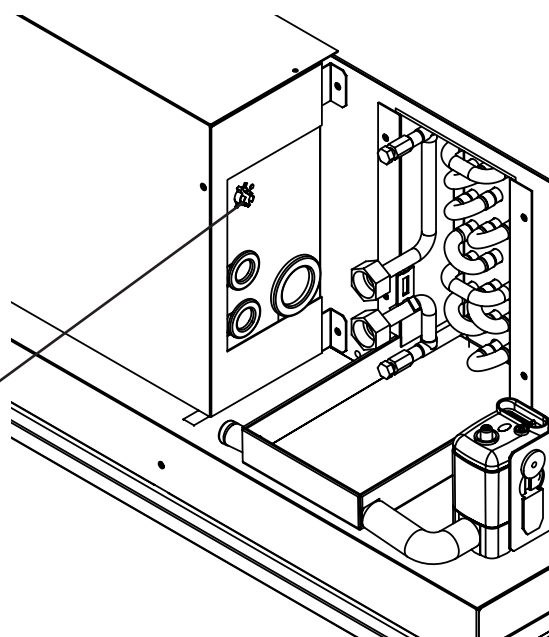

**THE ELECTRIC HEATING RESISTANCES MUST NEVER OPERATE WITHOUT VENTILATION.**

## COMMISSIONING

### PRE-START CHECK LIST

#### ELECTRICAL CHECK

1. Electrical installation has been carried out according to unit wiring diagram and the Supply Authority Regulations.
2. size fuses or circuit breaker has been installed at the main switchboard.
3. Supply voltages as specified on unit wiring diagram.
4. All cables are properly identified and tight connected at the unit.
5. the cables and wires are clear of or protected from pipework and sharp edges.

#### HYDRAULIC CHECKS

1. Check that the water inlet and outlet pipes are connected and tightened correctly.
2. Check that the hydraulic circuit is filled correctly and that the fluid flows freely without any signs of leaks or air bubbles. When ethylene glycol anti-freeze is used, check that the concentration level is correct.
3. Check that the condensate drainage pipe is connected properly in accordance with the instructions.
4. Drain the water from the tray and check property gravity drainage or proper drainage by the lift pump.  
If the water does not drain away properly, check the slope angle or look for a possible pipe blockage.

#### VISUAL CHECK

1. Unit assembly in accordance with specifications.
2. Presence and tightness of screws and nuts.
3. Absence of water leaks at connection points and on the various components.
4. Check that the air filter is clean and installed properly.
5. Check that the fan rotates freely.

### FINAL TASKS

Place the plugs back on the valves and check that they are properly tightened.

If needed, fix the cables and the pipes on the wall with clamping collars.

Operate the air conditioner in the presence of the user and explain all functions.

Show him how to remove, clean and place back the filters.

#### Take care

It is not the manufacturer's policy to make recommendations in terms of water treatment (please contact a specialised water treatment company).

However, given the critical nature of this subject, particular care should be taken to ensure that, if treatment is required, it works effectively.

Using untreated or unsuitable water leads to excessive clogging inside the coil tubes (earth and mud deposits, corrosion, etc.) with major consequences on the thermal efficiency of the unit and irreversible damage to the equipment.

The manufacturer and its representative decline all responsibility in the event of untreated or incorrectly treated water being used.

### **IN CASE OF WARRANTY - MATERIAL RETURN PROCEDURE**

Material must not be returned without permission of our After Sales Department.

To return the material, contact your nearest sales office and ask for a "return voucher". The return voucher shall be sent with the returned material and shall contain all necessary information concerning the problem encountered.

The return of the part is not an order for replacement. Therefore, a purchase order must be entered through your nearest distributor or regional sales office. The order should include part name, part number, model number and serial number of the unit involved.

Following our personal inspection of the returned part, and if it is determined that the failure is due to faulty material or workmanship, and in warranty, credit will be issued on customer's purchase order. All parts shall be returned to our factory, transportation **CHARGES PREPAID**.

### **ORDERING SERVICE AND SPARE PARTS ORDER**

The part number, the order confirmation and the unit serial number indicated on the name plate must be provided whenever service works or spare parts are ordered.

For any spare part order, indicate the date of unit installation and date of failure. Use the part number provided by our service spare parts, if it not available, provide full description of the part required.



## MAINTENANCE



The user is responsible for ensuring that it is in a proper working condition and that technical installation as well as the regular maintenance operations are performed by properly trained technicians and in accordance with the instructions contained in this manual.

### REGULAR MAINTENANCE

These units have been designed for minimum maintenance through the use of permanently lubricated components. However, there are operational maintenance requirements that require regular attention to ensure optimum performance.

Maintenance must be performed by appropriately experienced personnel only.

**WARNING :** Isolate unit from power supply before working on unit.

### GENERAL INSPECTION

Carry out a visual inspection of the complete installation in service.

Check the general cleanness of the installation.

### AIR FILTER

The filter must be cleaned frequently in order to prevent partial clogging and a loss of airflow. We recommend that it is cleaned every 3 months or replaced, as required, between periods of operation in heating and cooling mode.

To remove the filter, press the push buttons situated on the intake grille. The grille tips forward to provide access to the filter. In the case of an apparatus without a height adjuster, do not tip the inlet grille completely through 90° as there is a risk of damage to the fan/motor assembly. Simply tip the grille sufficiently to gain access to the filter.

It is especially unadvisable to operate the apparatus without a filter, as there is a risk of clogging the battery and damaging the unit's thermal performances.



### COIL

The coil's state of cleanliness is not only a decisive factor feature in guaranteeing optimum thermal exchange but also in ensuring treated air quality. For this reason, we recommend cleaning the coil between seasons.

To achieve this, simply:

1. Remove the 4 tray + coil attachment screws (1).
2. Remove the condensate drainage pump attachment screws (2).
3. Disconnect the hose (3) linking the tray to the pump.
4. Slide the tray + coil assembly towards the exterior.

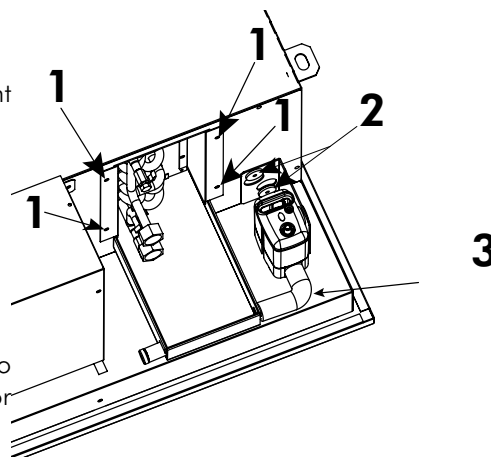

Use a vacuum cleaner or compressed air to clean the coil.

Note: When removing and handling the battery, take care not to crush the fins. We recommend the use of an appropriate brush for cleaning them.

### CONDENSATE TRAY

The condensate tray must be inspected at regular intervals for cleanliness and to ensure that the drainage tube is not blocked. If required, we recommend the use of a non-abrasive soapy product to clean the tray.

To remove the tray, follow the instructions relating to battery removal.

### FAN MOTOR ASSEMBLY

The fan motor assembly does not require any particular maintenance. However, each time regular maintenance is performed, the fan should be inspected to check that it turns freely without friction.

In the event of the fan motor overload protection device engaging, wait for the automatic protection to reset itself and seek out the cause of the protection device being triggered.

To remove the fan motor assembly :

- Open the intake grille.
- Disconnect the fan motor assembly power supply starting from the electric box.
- Unscrew the 4 fan motor assembly retaining screws.

### KCO LN 60

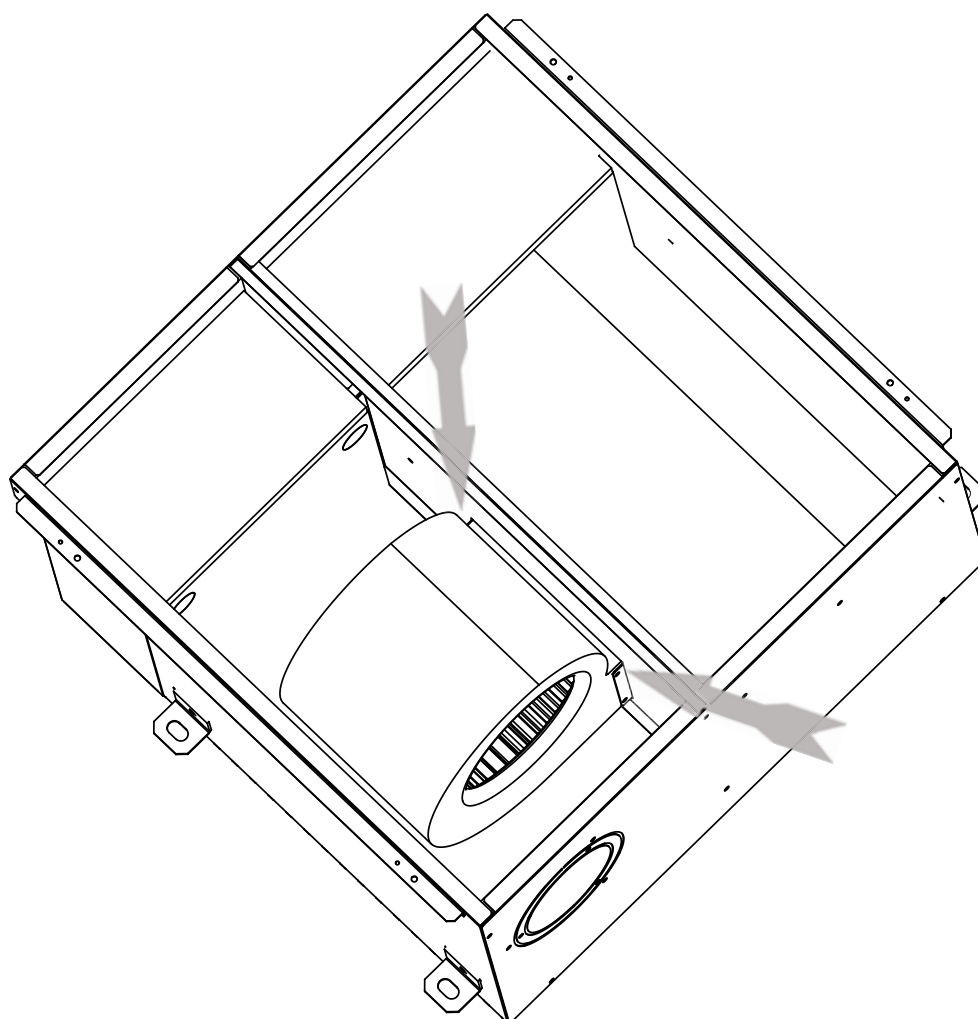

KCO LN 90

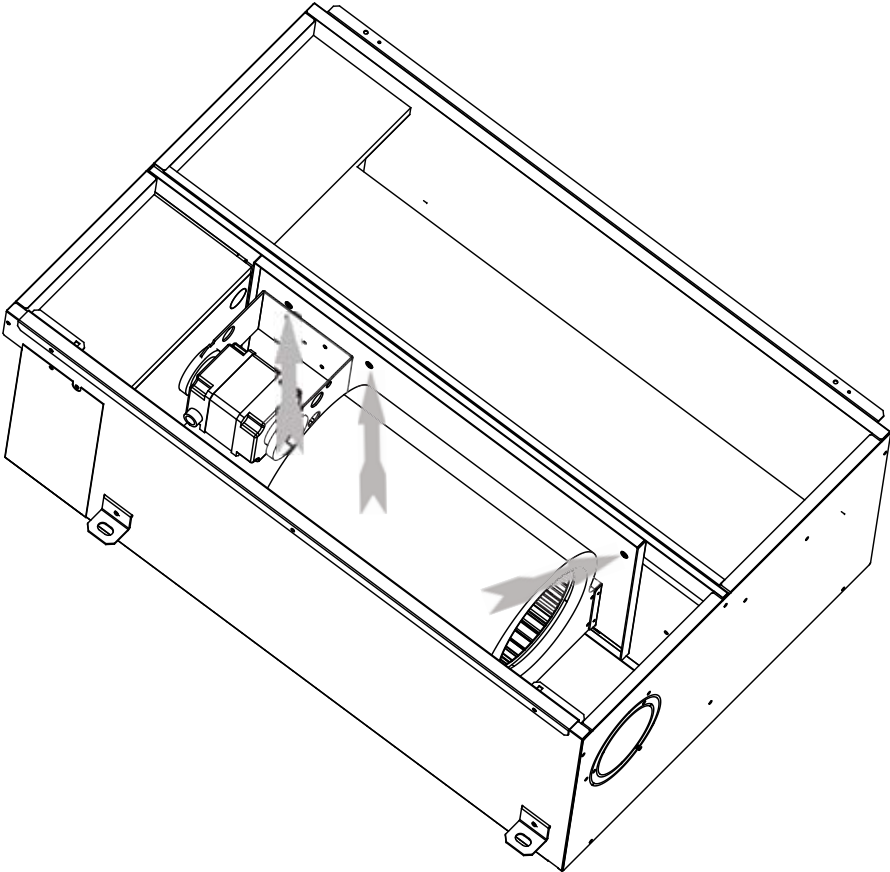

KCO LN 120

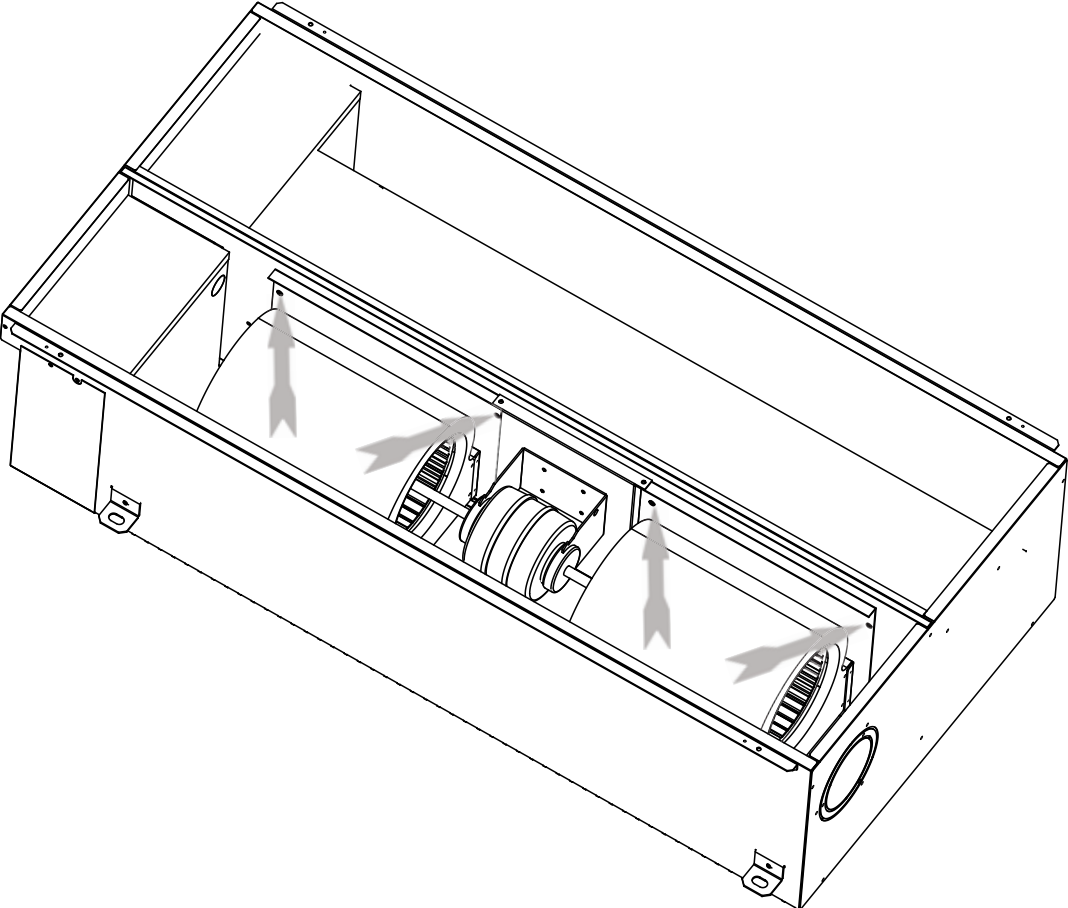

## ELECTRICAL SECTION

Check that the main power supply cable is not damaged or altered in such a way as to affect the insulation

Check that the interconnecting cables between the two units are not damaged or altered, and that they are correctly connected.

The contact surfaces of relays and contactors should be inspected regularly by an electrician and replaced as judged necessary. On these occasions the control box should be blown out with compressed air to remove any accumulation of dust or other contaminants.

Check the earth grounding connection.



### CAUTION

**BEFORE CARRYING OUT ANY OPERATION ON THE EQUIPMENT,  
CHECK THAT THE ELECTRICAL POWER SUPPLY IS SWITCHED OFF  
AND THAT IT CANNOT BE SWITCHED ON INADVERTENTLY.**





**APPENDIX**  
**ANNEXE**  
**ANLAGE**  
**ALLEGATO**  
**ANEXO**

---

## APPENDIX

DIMENSIONS .....	III
WIRING DIAGRAM .....	V
CHANGING THE FAN-MOTOR UNIT SPEED .....	X
MULTIDIRECTIONAL DIFFUSERS .....	XVI
AIR JET REACH .....	XIX

## ANNEXE

DIMENSIONS .....	III
SCHEMAS ELECTRIQUES .....	V
MODIFICATION DE LA VITESSE DU GROUPE MOTO-VENTILATEUR.....	X
DIFFUSEURS ORIENTABLES .....	XVI
PORTÉE DU JET D’AIR .....	XIX

## ANLAGE

ABMESSUNGEN .....	III
STROMLAUFPLANS.....	V
ÄNDERUNG DER DREHZAHL DES LÜFTERSATZES.....	X
RICHTUNGSUNABHÄNGIGE DIFFUSER.....	XVI
REICHWEITE DES LUFTSTRAHLS .....	XIX

## ALLEGATO

DIMENSIONI .....	III
SCHEMA ELETRICO .....	V
MODIFICA DELLA VELOCITA DEL GRUPPO MOTOVENTILATORE .....	X
DIFFUSORI ORIENTABIL .....	XVI
PORTATA DEL GETTO D’ARIA .....	XIX

## ANEXO

DIMENSIONES .....	III
ESQUEMA ELECTRICO.....	V
MODIFICACIÓN DE LA VELOCIDAD DEL GRUPO MOTOVENTILADOR .....	X
DIFUSORES MULTIDIRECCIONALES.....	XVI
ALCANCE DEL CHORRO DE AIRE .....	XIX



DIMENSIONS  
 DIMENSIONS  
 ABMESSUNGEN  
 DIMENSIONI  
 DIMENSIONES

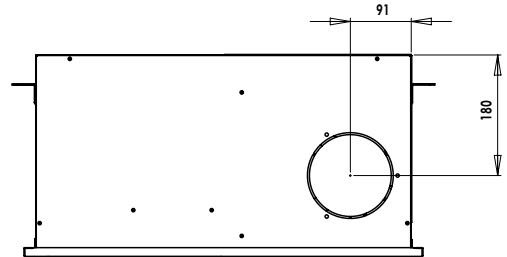
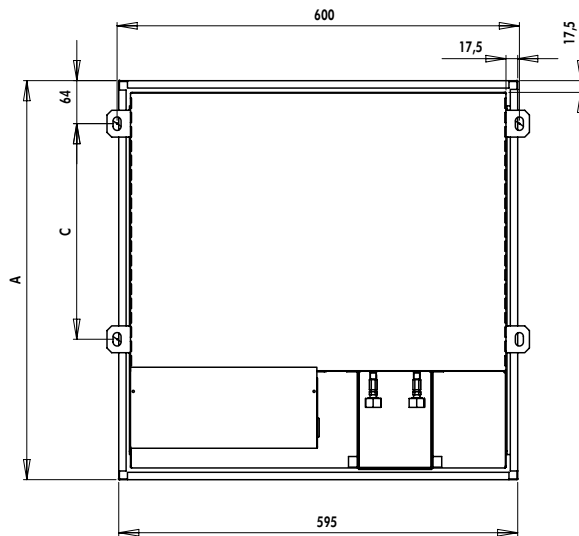
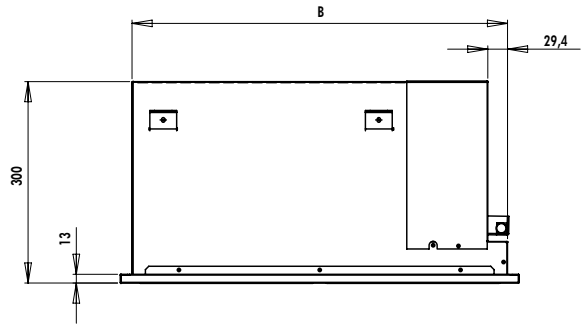
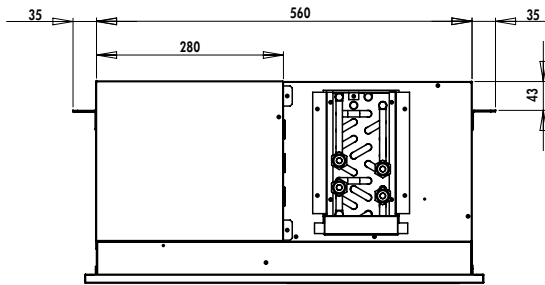
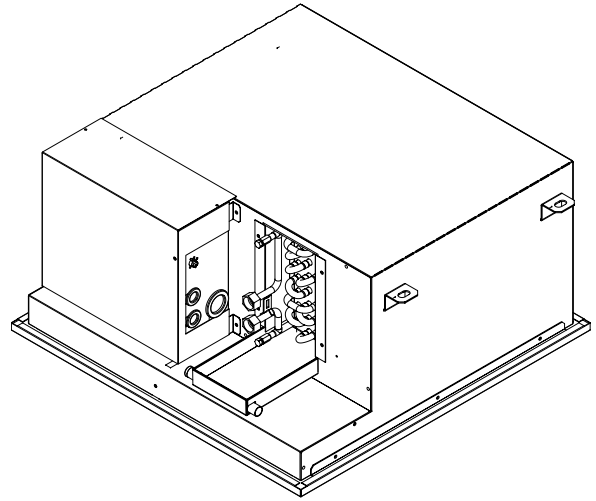

	A	B	C
60	595	560	320
90	895	860	620
120	1195	1160	920

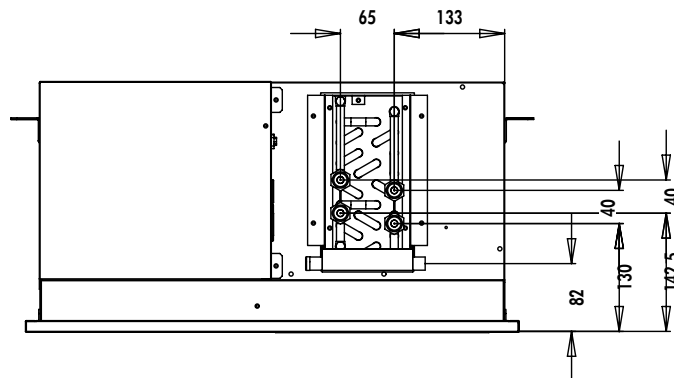
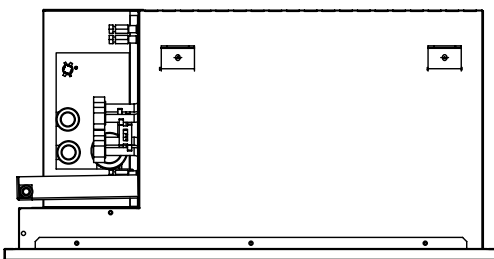

APPENDIX / ANNEXE / ANLAGE / ALLEGATO / ANEXO

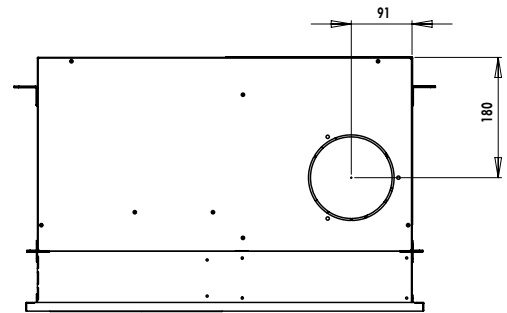
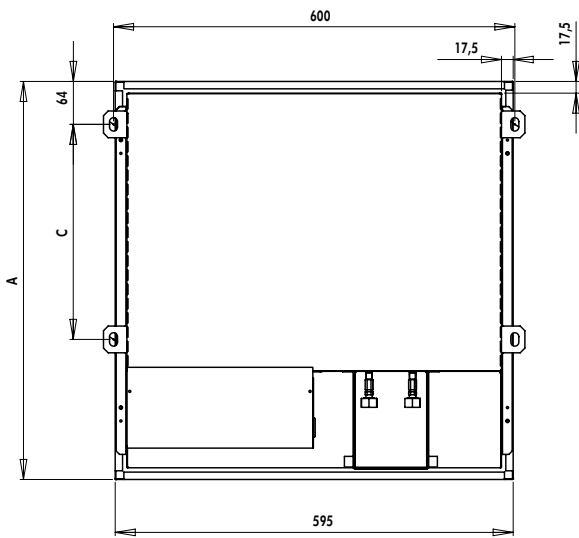
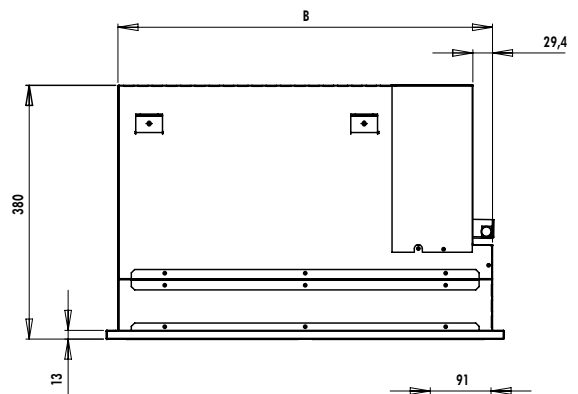
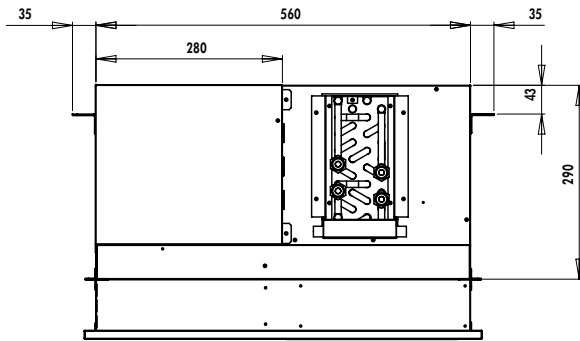
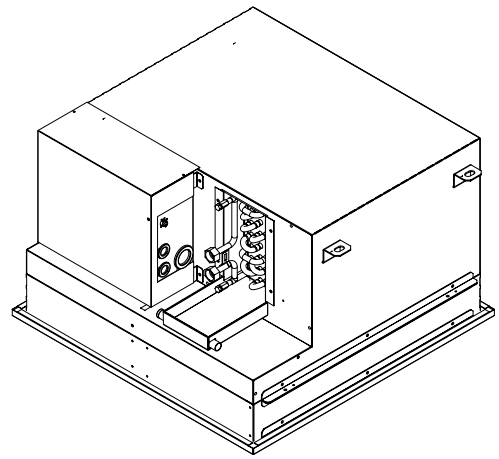

	A	B	C
60	595	560	320
90	895	860	620
120	1195	1160	920

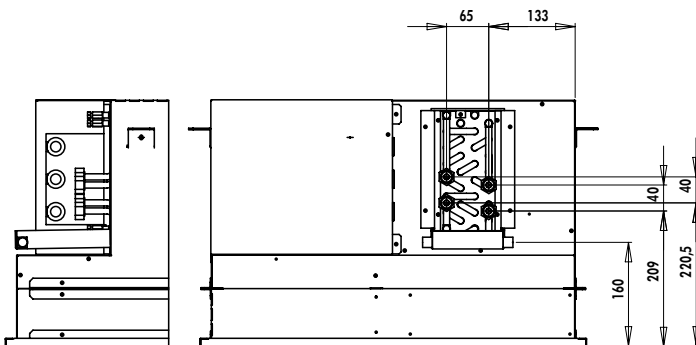

**WIRING DIAGRAM**

**SCHEMAS ELECTRIQUES**

**STROMLAUFPLANS**

**SCHEMA ELETRICO**

**ESQUEMA ELECTRICO**

**TAKE CARE!**

These wiring diagrams are correct at the time of publication. Manufacturing changes can lead to modifications. Always refer to the diagram supplied with the product.

**ATTENTION**

Ces schémas sont corrects au moment de la publication. Les variantes en fabrication peuvent entraîner des modifications. Reportez-vous toujours au schéma livré avec le produit.

**ACHTUNG!**

Diese Stromlaufpläne sind zum Zeitpunkt der Veröffentlichung gültig. In Herstellung befindliche Varianten können Änderungen mit sich bringen. In jedem Fall den mit dem Produkt gelieferten Stromlaufplan hinzuziehen.

**ATTENZIONE !**

Questi schemi sono corretti al momento della pubblicazione. Le varianti apportate nel corso della fabbricazione possono comportare modifiche. Far sempre riferimento allo schema fornito con il prodotto.

**ATENCIÓN !**

Esto esquemas son correctos en el momento de la publicación. Pero las variantes en la fabricación pueden ser motivo de modificaciones. Remítase siempre al esquema entregado con el producto.

**POWER SUPPLY MUST BE SWITCHED OFF BEFORE STARTING TO  
WORK IN THE ELECTRIC CONTROL BOXES!**



**MISE HORS TENSION OBLIGATOIRE AVANT TOUTE INTERVENTION  
DANS LES BOITIERS ELECTRIQUES.**

**VOR JEDEM EINGRIFF AN DEN ANSCHLUßKÄSTEN UNBEDINGT  
DAS GERÄT ABSCHALTEN!**

**PRIMA DI OGNI INTERVENTO SULLE CASSETTE ELETTRICHE  
ESCLUDERE TASSATIVAMENTE L'ALIMENTAZIONE !**

**PUESTA FUERA DE TENSION OBLIGATORIA ANTES DE CUALQUIER  
INTERVENCIÓN EN LAS CAJAS ELÉCTRICAS!**

"KCO" ERAU GLACEE 2 TUBES  
 CHILLED WATER "KCO" 2 PIPE  
 KALTWASSER"KCO" 2 ROHREN  
 "KCO" AGUA HELADA 2 TUBOS  
 "KCO" ACQUA GHIACCIAIA 2 TUBI

LE CHAUFFAGE DOIT ETRE RESERVEIS A LA VENTILATION  
 HEATER MUST RUN WITH FANMOTOR  
 HEIZUNG MUSS MIT LUFTMOTOR ARBEITEN  
 LA CALIFACCION DEBE FUNCIONAR CON EL VENTILADOR EN MARCHA  
 RISCALDAMENTO DOVERE FUNZIONARE CON LE VENTILATORE

230V ~ 50 Hz  
 CODE : 399835 SE 3392 A

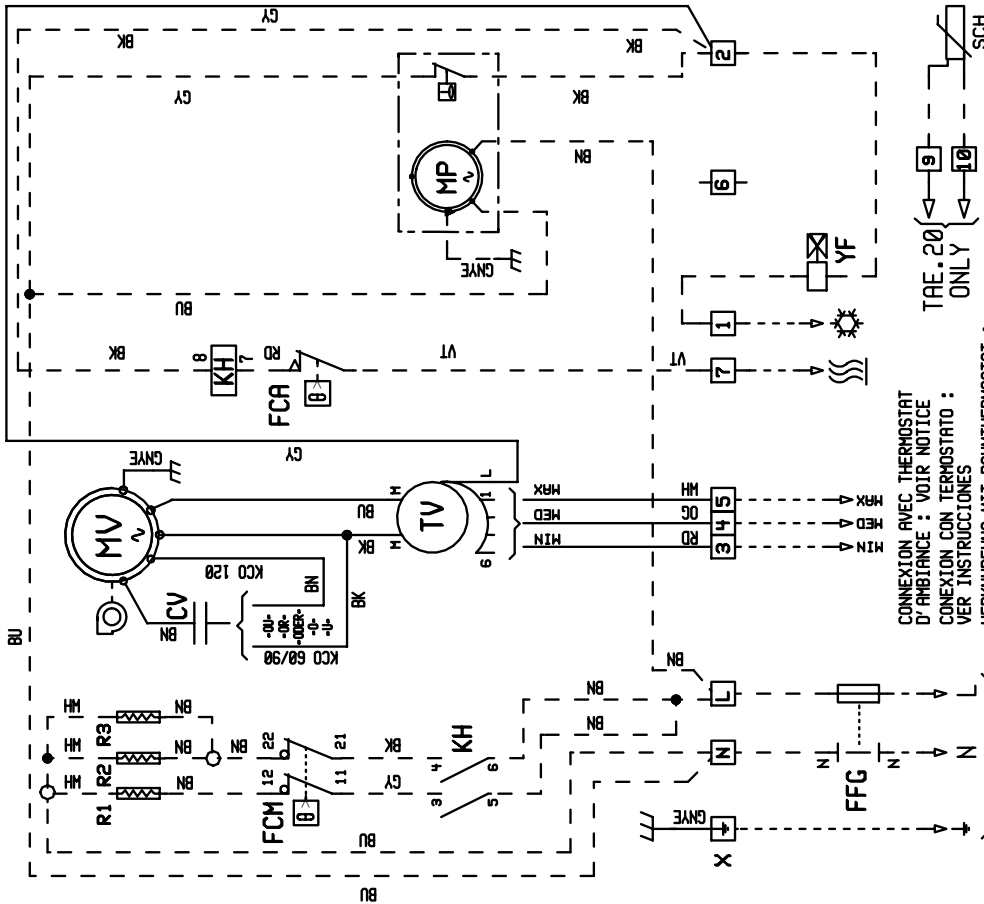

CONNECTION AVEC THERMOSTAT  
 D'AMBIANCE : VOIR NOTICE  
 CONEXION CON THERMOSTATO :  
 VER INSTRUCCIONES  
 VERKNÜPFUNG MIT RAUMTHERMOSTAT :  
 SIEHE BERECHNUNGEN  
 CONNECTION WITH ROOM THERMOSTAT :  
 SEE NOTICE  
 COLLEGAMENTO ALLO THERMOSTATO :  
 REFERIMENTO ALLO ISTRUZIONI

230V ~ 50Hz + ~

- MP MOTEUR POMPE CONDENSAT  
 MV MOTEUR VENTILAT. PROTEGE TERMIOU.  
 CV CONDENSATEUR  
 TV AUTOTRANSFORMATEUR MOTEUR MV  
 YF VANNE 3 VOIES  
 SCH SONDE DE TEMPERATURE D'EAU  
 X BORNIER DE RACCORDEMENT  
 KH CONTACTEUR CHAUFFAGE ELECTRIQUE  
 R1/R2/R3 RESIST. CHAUFFAGE ELECT.  
 FCA THERMOSTAT SECURITE AUTO.  
 FCM SECURITE MANUELLE  
 FFG PROTECTION (OPTION)

- MP MOTOR PUMP CONDENSAT  
 MV LUFTMOTOR TERMISH GESICHERT  
 CV KONDENSATOR  
 TV SPARTRANSFORMATOR (LUFTMOTOR MV)  
 YF 3 WEG WASSERSCHIEBER  
 SCH WASSER TEMPERATURESONDE  
 X KLEMMLEISTE  
 KH ELEKTROHEIZUNGSSCHUTZ  
 R1/R2/R3 ELEKTROHEIZUNGSWIDERSTAND  
 FCA UBERHEIZUNGSSCHUTZ  
 FCM HANDBERHITZUNGSSCHUTZ  
 FFG VORSICHERUNG (OPTION)

BK	NOIR	BLACK	SCHWARZ
BN	BRUN	BROWN	BRAUN
BU	BLEU	BLUE	BLAU
GNVE	VERT./JA.GREEN/YELL.	GRIN/CELLB	
GY	GRIS	GREY	GRAU
OG	ORANGE	ORANGE	
RD	ROUGE	RED	ROT
VT	VIOLET	PURPLE	VIOLETT
HH	BLANC	WHITE	HEISS
BK	NEGR0	NERO	
BN	MARRON	BARRONE	
BU	AZUL	BLU	
GNVE	VERDE/AMAR.	GIALLO/VERDE	
GY	GRIS	GRIGIO	
OG	MARRONJA	ARRANCIONE	
RD	ROJO	ROSSO	
VT	VIOLETA	VIOLETA	
HH	BLANCO	BIANCO	

- MP CONDENSATE PUMP MOTOR  
 MV FAN MOTOR THERMALLY PROTECTED  
 CV CAPACITOR  
 TV AUTOTRANSFORMER (FAN MOTOR MV)  
 YF 3 WAY VALVE (OPTIONAL)  
 SCH WATER TEMPERATURE SENSOR  
 X TERMINAL STRIP  
 FFG CIRCUIT-BREAKER (OPTIONAL)  
 KH ELECTRIC HEATING CONTACTOR  
 R1/R2/R3 ELECTRIC HEATER  
 FCA SECURITY THERMOSTAT  
 FCM MANUAL SECURITY THERMOSTAT

- MV MOTOR VENTILA. PROTECC.POR KLIXON  
 MP MOTOR BOMBA CONDENSADO  
 CV CONDENSADOR  
 TV AUTOTRANSFORMADOR (MOTOR VENTIL.)  
 YF ELECTROVALVULA  
 SCH SONDRA TEMPERATURA AGUA  
 X BORNERA DE CONEXION  
 KH CONTACTOR CALEFACCION ELECTRICO  
 R1/R2/R3 RESIST.CALEFACCION ELECTRICO  
 FCA TERMOSTATO DE SEGURIDAD  
 FCM SEGURIDAD MANUAL  
 FFG PROTECCION (OPCIONE)

- MV MOTORE VENTILA. PROTEZIONE TERMICA  
 MP MOTORE POMPA CONDENSATO  
 CV CONDENSATORE  
 TV AUTOTRASFOMATORE (MOTORE VENTIL.)  
 YF VALVOLA 3 VIE  
 SCH SONDA DI TEMPERATURA DELL'AGUA  
 X MORSIETTIERA DI COLLEGAMENTO  
 KH CONTATTORE RISCALDAMENTO ELECTRIC  
 R1/R2/R3 RESIST. RISCALDAMENTO ELECTRIC  
 FCA TERMOSTATO SICUREZZA AUTOMATICA  
 FCM SICUREZZA MANUALE  
 FFG PROTEZIONE (OPZIONE)

"KCO" EAU GLACEE 2 TUBES  
 "KCO" CHILLED WATER "KCO" 2 PIPE  
 "KCO" KALTWASSER "KCO" 2 ROHREN  
 "KCO" AGUA HELADA 2 TUBOS  
 "KCO" ACQUA GHIACCIATA 2 TUBI

230V ~	50 Hz
CODE : 399836	SE 3393

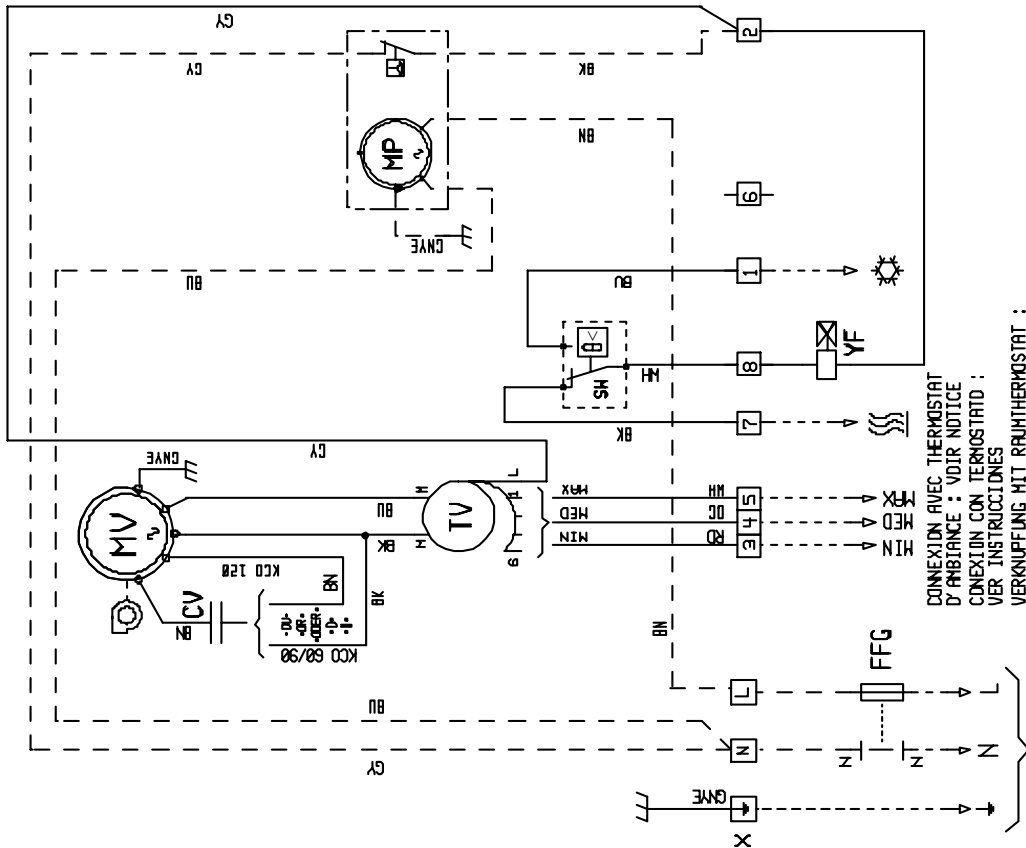

CONNEXION AVEC THERMOSTAT  
 D'AMBIANCE : VOIR NOTICE  
 CONEXION CON THERMOSTATO :  
 VER INSTRUCTIES  
 VERKNIIPUNG MIT RAUMTHERMOSTAT :  
 SIEHE BEWEKUNGEN  
 CONNECTION WITH ROOM THERMOSTAT :  
 SEE NOTICE  
 COLLEGAMENTO ALLO THERMOSTATO :  
 RIFERIMENTO ALLE ISTRUZIONI

OPTION/OPTIONAL/  
 OPTIONAL/OPTIONALE

- MP MOTEUR POMPE CONDENSAT
  - MV MOTEUR VENTILAT. PROTEGE TERMIGU.
  - CV CONDENSATEUR
  - TV AUTOTRANSFORMATEUR MOTEUR MV
  - YF VANNE 3 VOIES
  - SH SONDIE DE TEMPERATURE D'EAU
  - X BORNIER DE RACCORDEMENT
  - FFG PROTECTION (OPTION)
- MP CONDENSATE PUMP MOTOR
  - MV FAN MOTOR THERMALLY PROTECTED
  - CV CAPACITOR
  - TV AUTOTRANSFORMER (FAN MOTOR MV)
  - YF 3 WAY VALVE (OPTIONAL)
  - SH WATER TEMPERATURE SENSOR
  - X TERMINAL STRIP
  - FFG CIRCUIT-BREAKER (OPTIONAL)

BK	NOIR	BLACK	SCHWARZ
BN	BRUN	BROWN	BRAUN
BU	BLEU	BLUE	BLAU
CV	VERT/JA. GREEN/YELL.	GRIN/GELB	
CG	GRIS	GREY	GRAU
OG	ORANGE	ORANGE	
RD	ROUGE	RED	ROT
VT	VIOLET	PURPLE	VIOLETT
WH	BLANC	WHITE	WEISS
BK	NERO	NERO	
BN	MARRON	MARRONE	
BU	AZUL	BLU	
CV	VERDE/AMR.	VERDE/VERDE	
CG	GRIS	GRIGIO	
OG	NARANJA	ARANCIONE	
RD	ROJO	ROSSO	
VT	VIOLETA	VIOLA	
WH	BLANCO	BIANCO	

- MV MOTOR VENTIL. PROTECC. POR KLIXON
- MP MOTOR BOMBA CONDENSADO
- CV CONDENSADOR
- TV AUTOTRANSFORMADOR (MOTOR VENTIL.)
- YF ELECTROVALVULA
- SH SONDIA TEMPERATURA AGUA
- X BORNIERA DE CONEXION
- FFG PROTECCION (OPCIONE)

"KCO" EAU GLACEE 4 TUBES  
 CHILLED WATER "KCO" 4 PIPE  
 KALTWASSER"KCO" 4 ROHREN  
 "KCO" AGUA HELADA 4 TUBOS  
 "KCO" ACQUA GHIACCIATA 4 TUBI

230V ~	50 Hz
CODE :399837	SE 3394

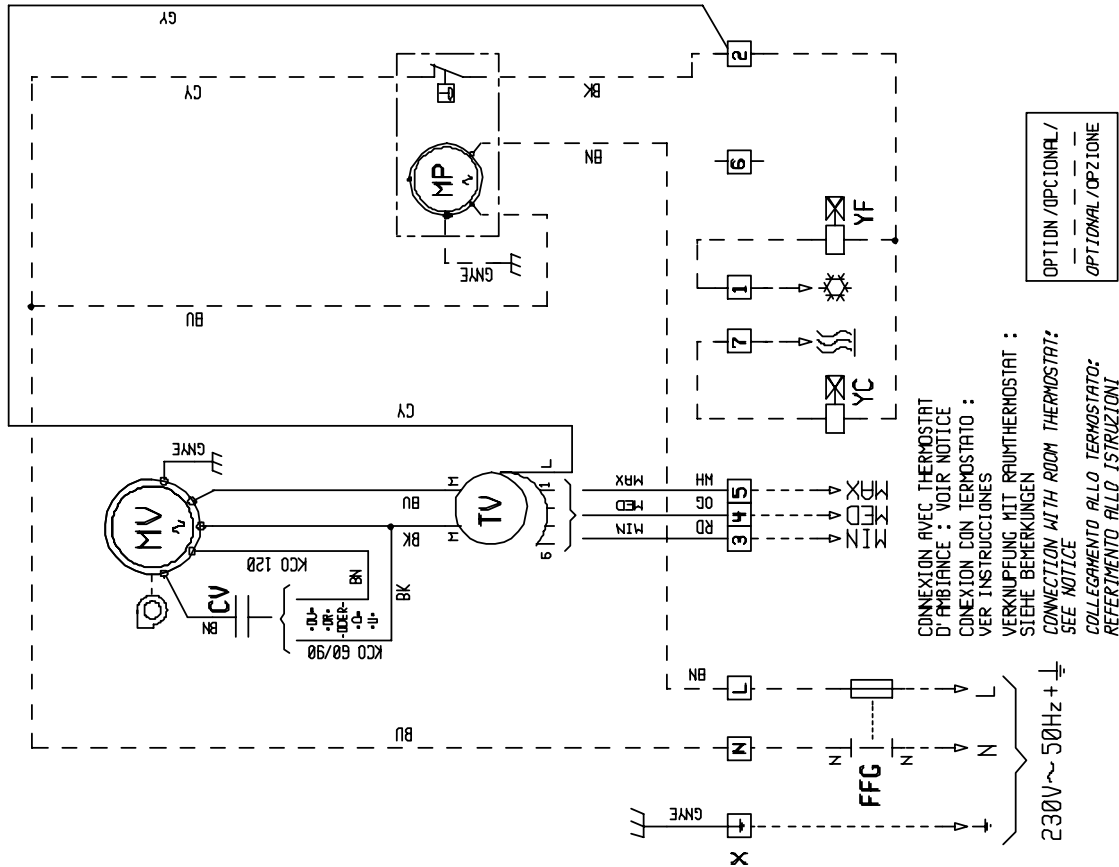

- MP MOTEUR POMPE CONDENSAT  
 MV MOTEUR VENTILAT. PROTEGE THERMO.  
 CV CONDENSATEUR  
 TV AUTOTRANSFORMATEUR MOTEUR MV  
 YF VANNE 3 VOIES  
 YC VANNE 3 VOIES  
 X BORNIER DE RACCORDEMENT  
 FFG PROTECTION (OPTION)
- MP MOTORPUMP KONDENSAT  
 MV LUFTELMOTOR TERMISH GESICHERT  
 CV KONDENSATOR  
 TV SPARTRANSFORMATOR (LUFTELMOTOR MV)  
 YF 3 WEG MASSERSCHIEBER  
 YC 3 WEG MASSERSCHIEBER  
 X KLEMMLEISTE  
 FFG VORSICHERUNG (OPTION)
- MP CONDENSATE PUMP MOTOR  
 MV FAN MOTOR THERMALLY PROTECTED  
 CV CAPACITOR  
 TV AUTOTRANSFORMER (FAN MOTOR MV)  
 YF 3 WAY VALVE (OPTIONAL)  
 YC 3 WAY VALVE (OPTIONAL)  
 X TERMINAL STRIP  
 FFG CIRCUIT-BREAKER (OPTIONAL)

BK	NOIR	BLACK	SCHWARZ
BN	BRUN	BROWN	BRAUN
BU	BLEU	BLUE	BLAU
GV	VERT/JA. GREEN/YELL.	GRUN/GELB	
GY	GRIS	GREY	GRAU
DC	ORANGE	ORANGE	
RD	ROUGE	RED	ROT
VT	VIOLET	PURPLE	VIOLETT
WH	BLANC	WHITE	WEISS
BK	NEGRO	NEGRO	NEGRU
BN	MARRON	MARRONE	
BU	AZUL	BLU	
GV	VERDE/AMAR.	GIALLO/VERDE	
GY	GRIS	GRIGIO	
DC	NARANJA	ARANCIONE	
RD	ROJO	ROSSO	
VT	VIOLETA	VIOLETA	
WH	BLANCO	BIANCO	

- MV MOTOR VENTILA. PROTECC. POR KLIXON  
 MP MOTOR BOMBA CONDENSADOR  
 CV CONDENSADOR  
 TV AUTOTRANSFORMADOR (MOTOR VENTIL.)  
 YF ELECTROVALVULA  
 YC ELECTROVALVULA  
 X BORNIERA DE CONEXION  
 FFG PROTECCION (OPCIONE)

CONNECTION AVEC THERMOSTAT  
 D'AMBIANCE : VOIR NOTICE  
 CONEXION CON THERMOSTATO :  
 VER INSTRUCCIONES  
 VERKNIIPFUNG MIT RAUMTHERMOSTAT :  
 SIEHE BEWERKUNGEN  
 CONNECTION WITH ROOM THERMOSTAT :  
 SEE NOTICE  
 COLLEGAMENTO ALLO THERMOSTATO :  
 RIFERIMENTO ALLO ISTRUZIONI

OPTION /OPCIONAL/  
 ---  
 OPTIONAL /OPZIONE

KCO EAU GLACEE 2/4 TUBES  
 KCO 2/4 PIPE CHILLED WATER  
 KCO 2/4 ROHREN KALTWASSER  
 KCO AGUA HELADA 2/4 TUBOS  
 KCO ACQUA GHIACCIATA 2/4 TUBI

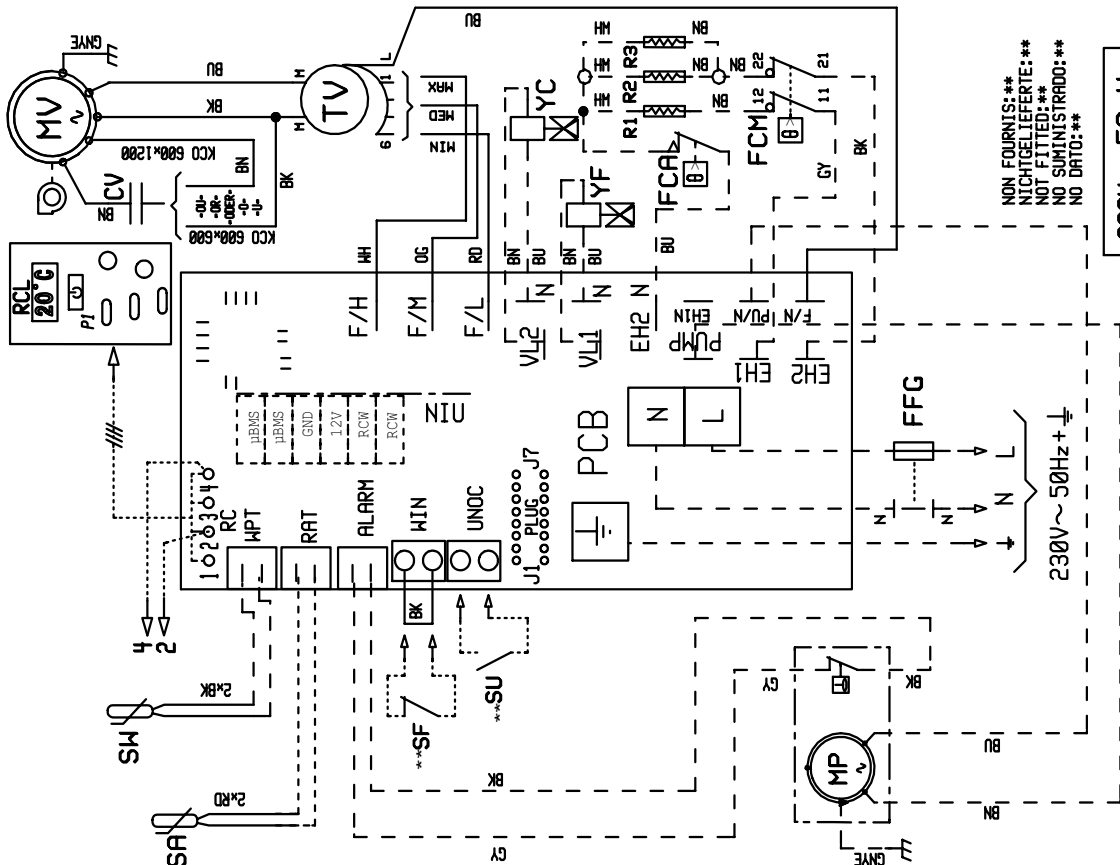

MP MOTEUR POMPE CONDENSAT  
 MV MOTEUR VENTILAT. PROTEGE TERMOU.  
 CV CONDENSATEUR  
 TV AUTOTRANSFORMATEUR MOTEUR MV  
 J1...J8 CONFIGURATEURS/CAVALLIERS  
 PCB/PCP PLATINE ELECTRONIQUE  
 SA SONDE TEMPERATURE REPRSE D' AIR  
 SF/SU CONTACT FENETRE/INOCCUPE\*\*  
 FFG PROTECTION (OPTION)  
 SH SONDE DE TEMPERATURE D' EAU  
 YF VANNE EAU FROIDE  
 YC VANNE EAU CHAUDE  
 R1/R2/R3 RESIST. CHAUFFAGE ELECTRIQUE  
 FCA THERMOSTAT SECURITE AUTOMATIQUE  
 FCM SECURITE MANUELLE

MP MOTORPUMP KONDENSAT  
 MV LUFTMOTOR TERMISH GESICHERT  
 CV KONDENSATOR  
 TV SPARTRANSFORMATOR (LUFTMOTOR MV)  
 J1...J8 REITCONFIG./STECKVERBINDER  
 PCB/PCP ELEKTRONISCHE BEDIENPLATINE  
 SA RUCKHOLLUFTSONDE  
 SF/SU FENSTER/UNBESATZKONTAKT\*\*  
 FFG VORSICHERUNG (OPTION)  
 SH WASSER TEMPERATURESONDE  
 YF KALTWASSER MAGNETVENTIL  
 YC WARMWASSER MAGNETVENTIL  
 R1/R2/R3 ELEKTROHEIZUNGWIDERSTAND  
 FCA UBERHEIZUNGSSCHUTZ  
 FCM HANDBERHEIZUNGSSCHUTZ

MP MOTORE POMPA CONDENSATO  
 MV MOTORE VENTIL. PROTECC.PER KLIXON  
 CV CONDENSATORE  
 TV AUTOTRANSFORMATORE (MOTORE VENTIL.)  
 J1...J8 SPINA/PONTICELLO  
 PCB/PCB PIASTRA ELETRONICA  
 SA SONDA DI TEMPERATURA DELL' ARIA  
 SF/SU INTERRUTTORE FINESTRA/ASSENTE\*\*  
 FFG PROTEZIONE (OPZIONE)  
 SH SONDA DI TEMPERATURA DELL' AGUA  
 YF VALVOLA FRI  
 YC VALVOLA CALO  
 R1/R2/R3 ELETTORISCALDATORE  
 FCA TERMOSTATO AUTOMATICA DI SICUREZZA  
 FCM SICUREZZA MANUAL

BK	NOIR	BLACK	SCHWARZ
BN	BRUN	BROWN	BRÄUN
BU	BLEU	BLUE	BLAU
GY	VERT./JA.GREEN/YELL.	GRUN/GELB	
OG	GRIS	GREY	GRAU
RD	ORANGE	ORANGE	ORANGE
VT	ROUGE	RED	ROT
WH	VIOLET	PURPLE	VIOLETT
	BLANC	WHITE	WEISS
BK	NERO	NERO	
BN	HARRON	BROWN	
BU	AZUL	BLU	
GY	VERDE/AMR.	GIALLO/VERDE	
OG	GRIS	GRIGIO	
RD	MARRON	ARANCIONE	
VT	ROJO	ROSSO	
WH	VIOLETA	VIOLA	
	BLANCO	BIANCO	

OPTION / OPCIONAL / ZUBEHOR / OPTIONAL / OPZIONE  
 SE 3395 A CODE : 339838  
 230V ~ 50 Hz

CHANGING THE FAN-MOTOR UNIT SPEED

MODIFICATION DE LA VITESSE DU GROUPE MOTO-VENTILATEUR

ÄNDERUNG DER DREHZAHL DES LÜFTERSATZES

MODIFICA DELLA VELOCITA DEL GRUPPO MOTOVENTILATORE

MODIFICACIÓN DE LA VELOCIDAD DEL GRUPO MOTOVENTILADOR

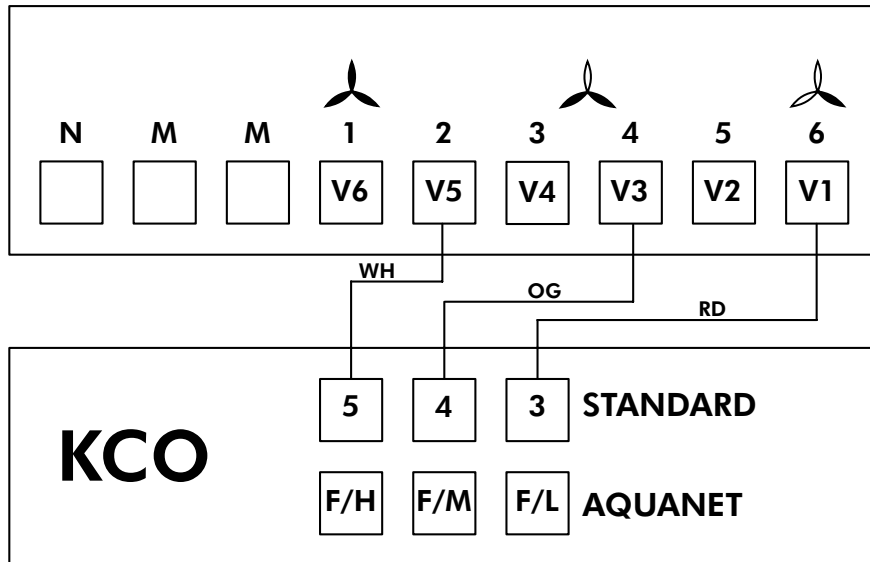

To change the wiring, change the transformer terminal connections.



**Never disconnect the wires connected to the terminal block or the Aquanet electronic module.**

Pour modifier le câblage changer la connexion sur les bornes du transformateur.



**Ne jamais déconnecter les fils raccordés sur le bornier ou sur le boîtier électronique Aquanet.**

Zur Änderung der Verdrahtung den Anschluss an den Transformator клемmen wechseln.



**Niemals die an die Klemmenleiste oder an das Elektronikgehäuse Aquanet angeschlossenen Drähte abklemmen.**

Per modificare il cablaggio, cambiare il collegamento sui morsetti del trasformatore.



**Non scollegare mai i fili collegati alla morsettiere o al contenitore elettronico Aquanet.**





Para modificar el cableado, cambiar la conexión en los bornes del transformador.





**No desconectar nunca los cables conectados en la placa de bornes o en la caja electrónica Aquanet.**



# APPENDIX / ANNEXE / ANLAGE / ALLEGATO / ANEXO

	2T	4T					
<b>GB</b>	2-PIPE COILS	4-PIPE COILS	COOLING	HEATING	LOW SPEED	MEDIUM SPEED	HIGH SPEED
<b>F</b>	BATTERIES 2 TUBES	BATTERIES 4 TUBES	FROID	CHAUD	PETITE VITESSE	VITESSE MOYENNE	GRANDE VITESSE
<b>D</b>	BATTERIEN 2 ROHREN	BATTERIEN 4 ROHREN	KÜHLUNG	HEIZUNG	KLEINE GESCHWINDIGKEIT	MITTLERE GESCHWINDIGKEIT	HOHE GESCHWINDIGKEIT
<b>I</b>	BATTERIE 2 TUBI	BATTERIE 4 TUBI	FREDDO	RISCALDO	BASSA VELOCITÀ	VELOCITÀ MEDIA	ALTA VELOCITÀ
<b>E</b>	BATERÍAS 2 TUBOS	BATERÍAS 4 TUBOS	FRIO	CALOR	VELOCIDAD BAJA	VELOCIDAD MEDIA	VELOCIDAD ALTA

			SCH	SW
<b>GB</b>	ELECTRIC HEATING	CONTROL VALVE	CHANGE OVER (TAE 20)	CHANGE OVER (TRM-FA TRM-VP)
<b>F</b>	CHAUFFAGE ELECTRIQUE	VANNE DE REGULATION	CHANGE OVER (TAE 20)	CHANGE OVER (TRM-FA TRM-VP)
<b>D</b>	ELEKTROHEIZUNG	REGELVENTIL	CHANGE OVER (TAE 20)	CHANGE OVER (TRM-FA TRM-VP)
<b>I</b>	RISCALDAMENTO ELETRICO	VALVOLA DI REGOLAZIONE	CHANGE OVER (TAE 20)	CHANGE OVER (TRM-FA TRM-VP)
<b>E</b>	CALEFACCION ELECTRICA	VÁLVULA REGULADORA	CHANGE OVER (TAE 20)	CHANGE OVER (TRM-FA TRM-VP)

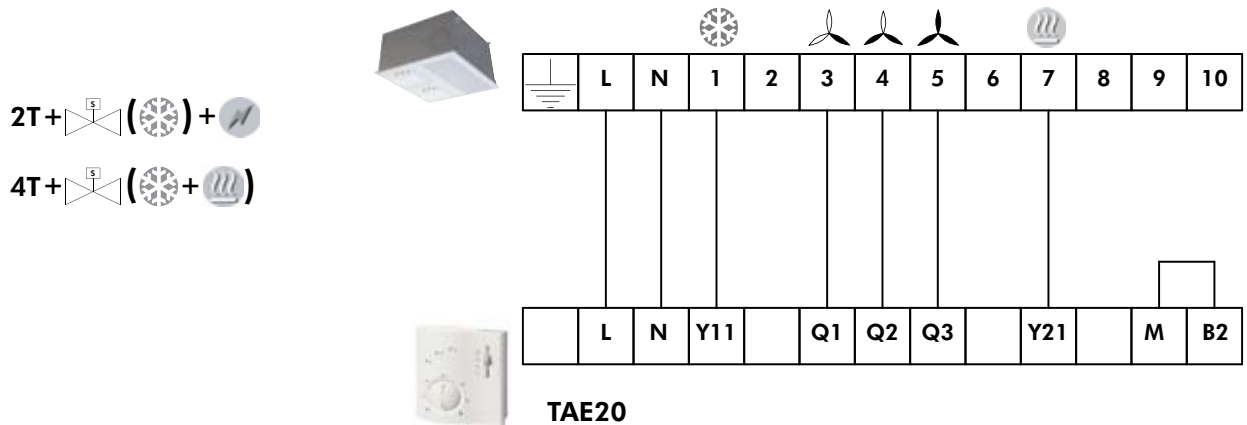
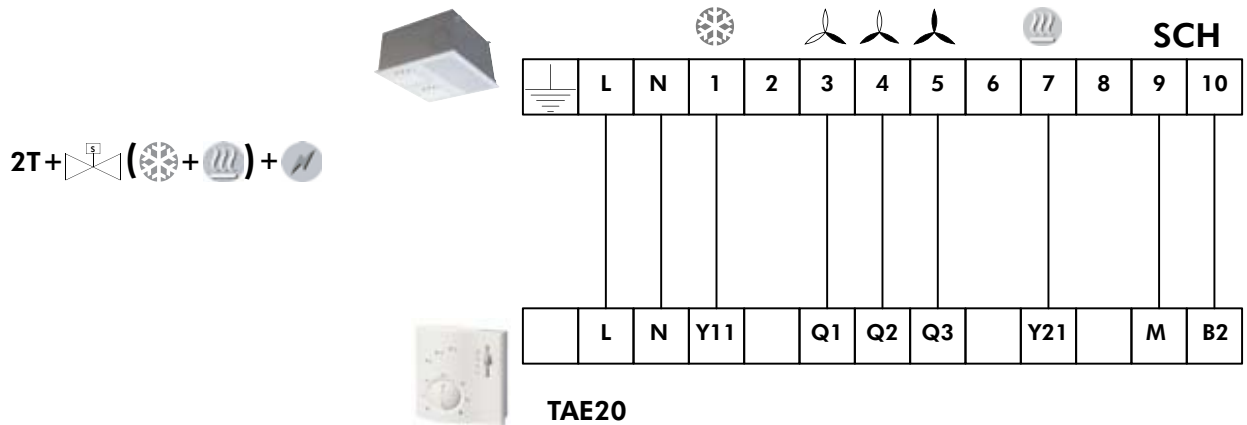

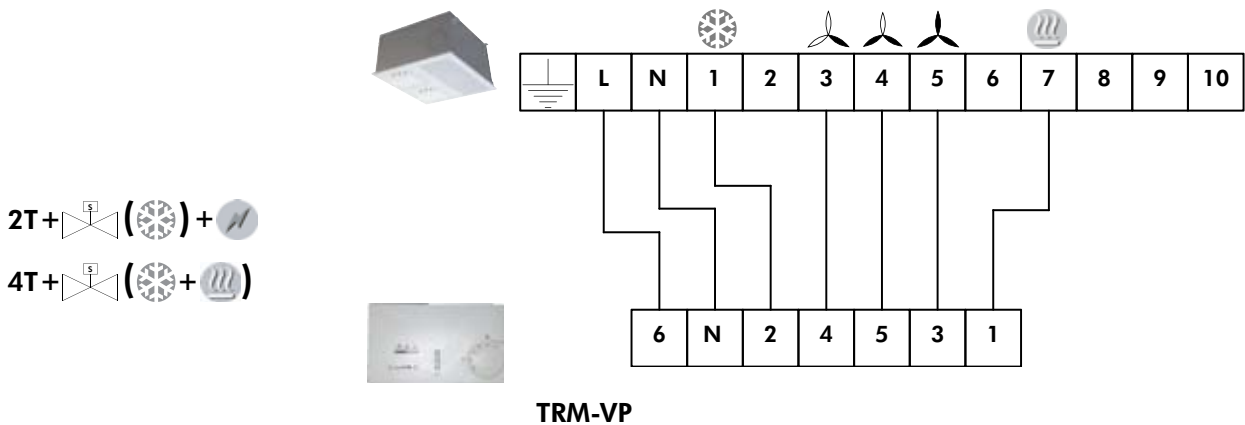
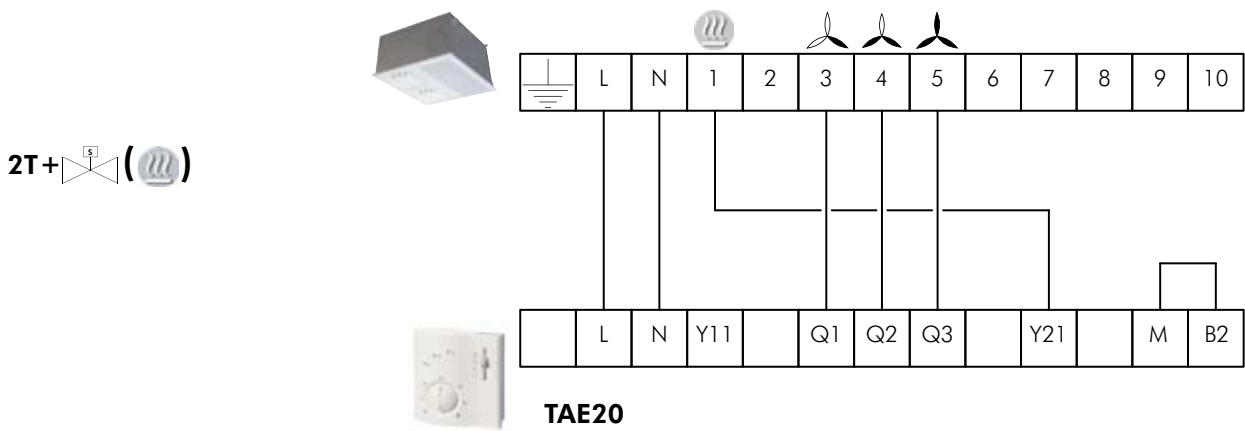
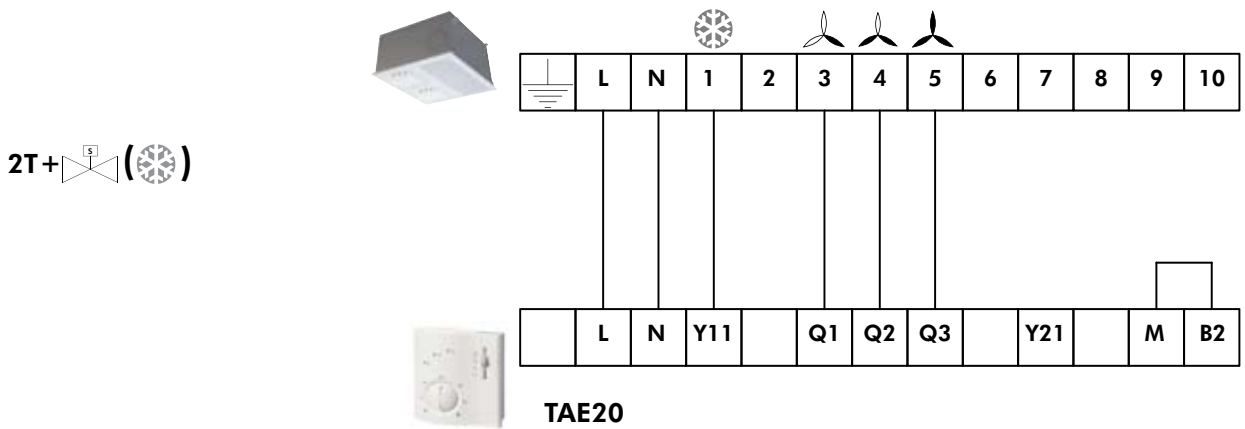
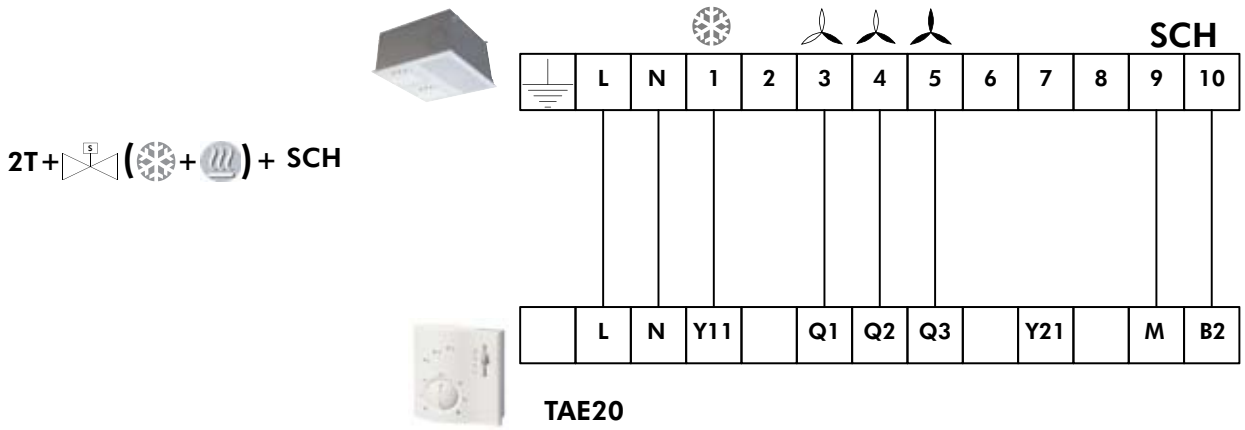

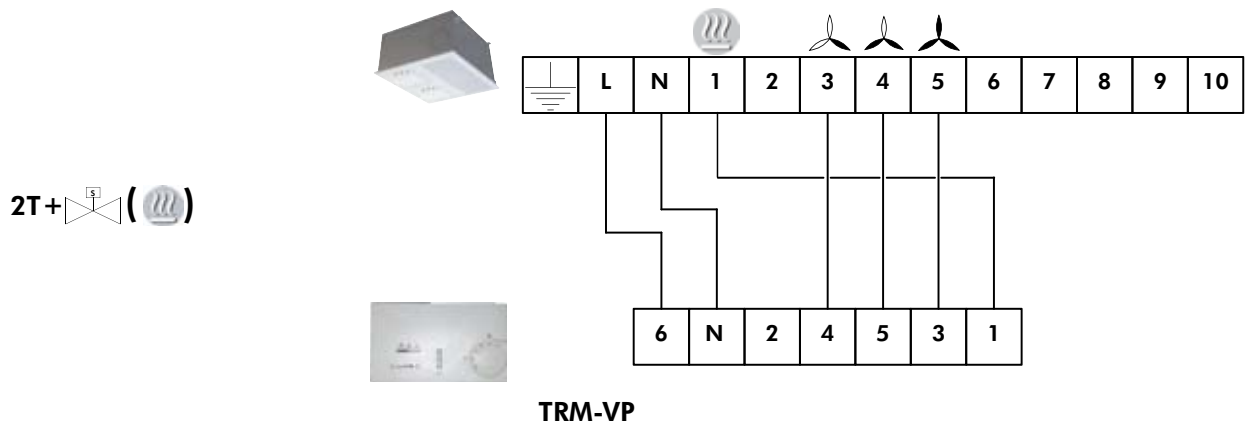
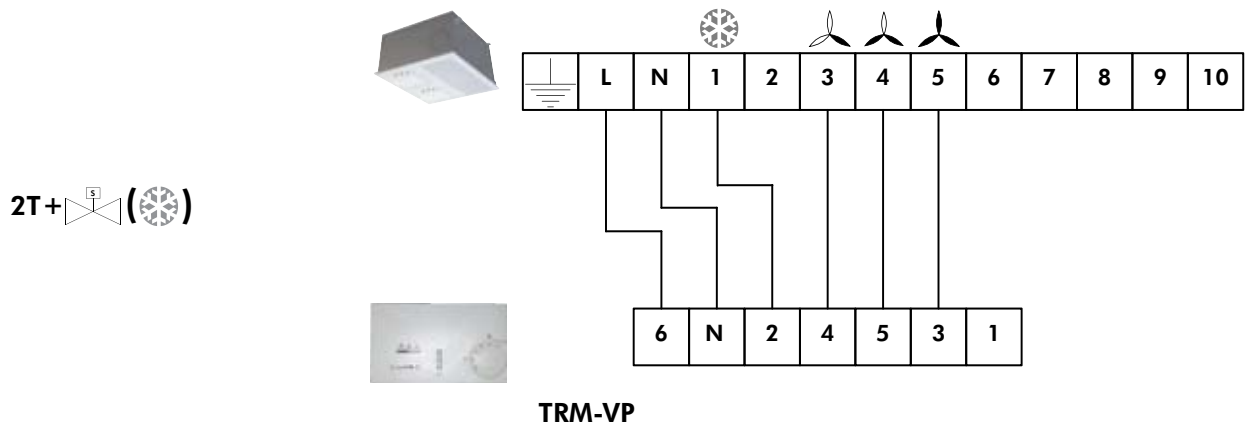
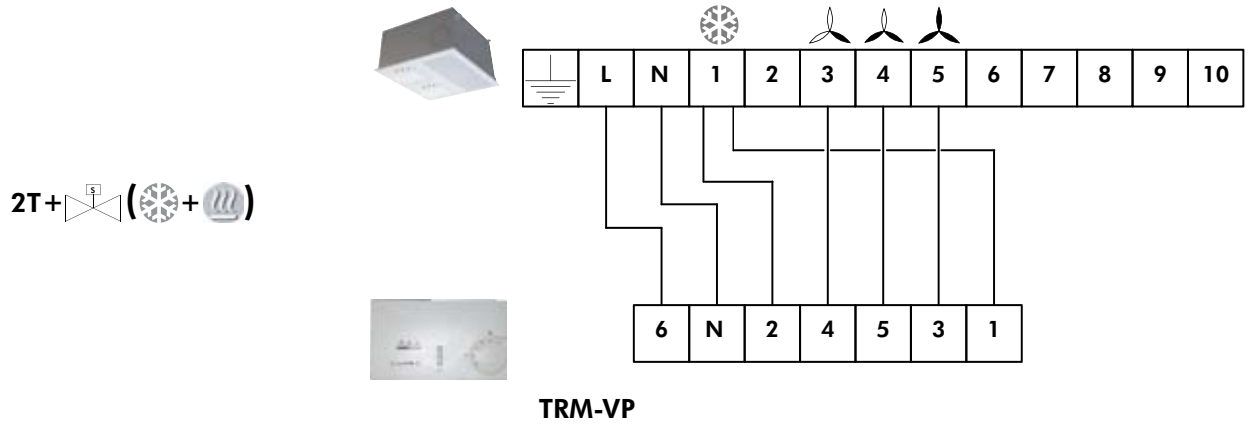
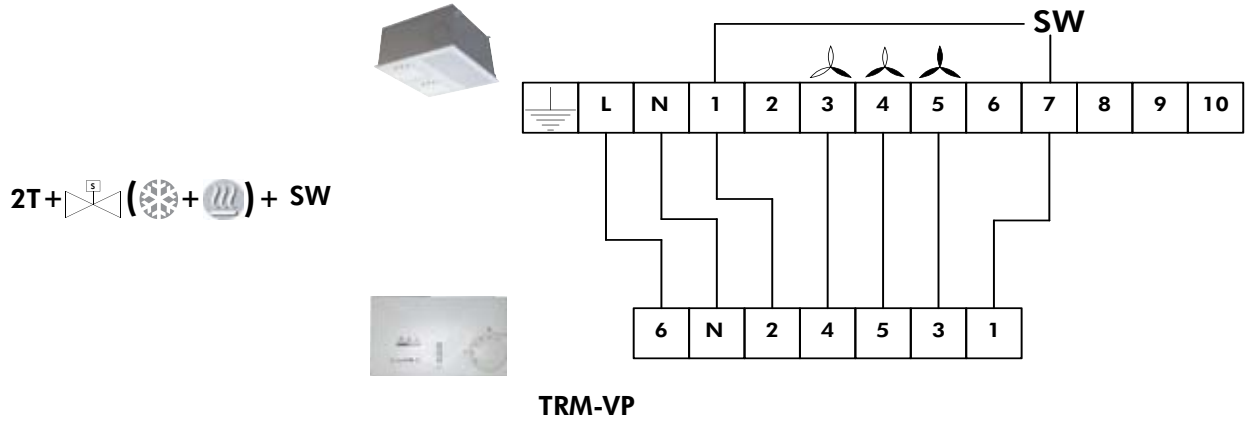

APPENDIX / ANNEXE / ANLAGE / ALLEGATO / ANEXO

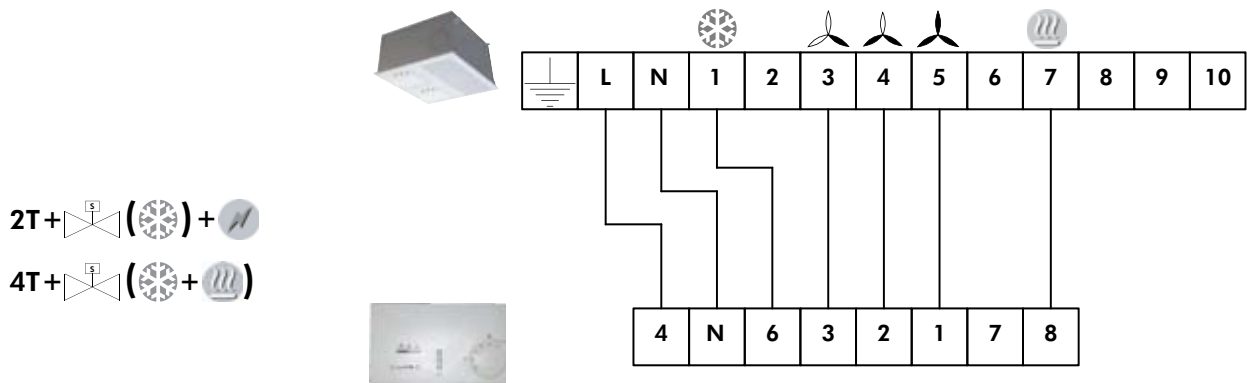

TRM-FA

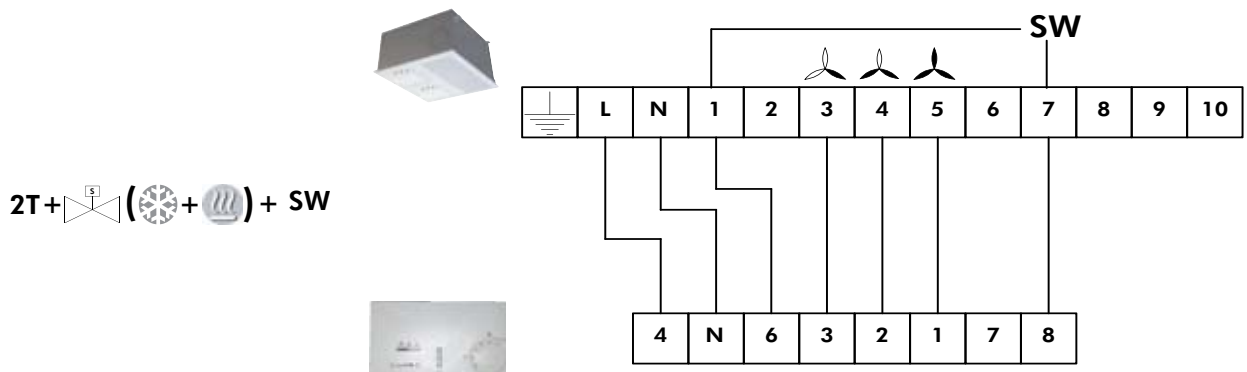

TRM-FA

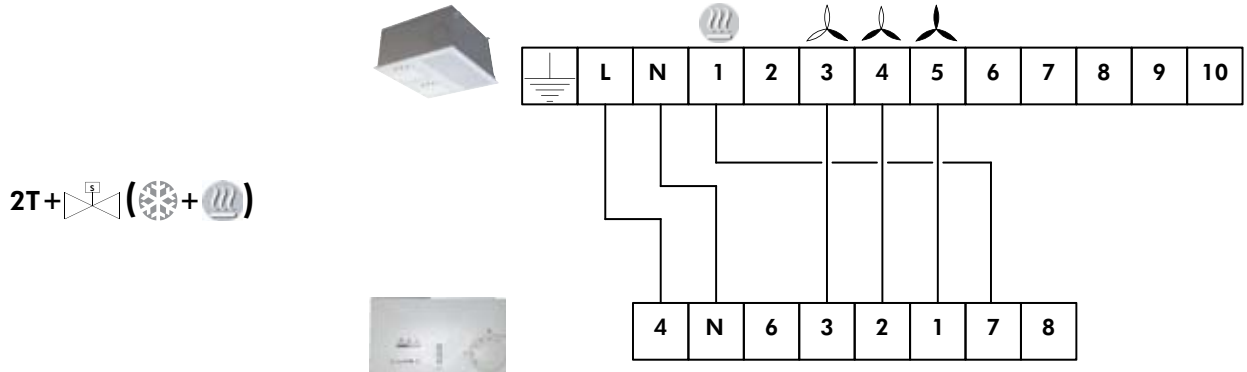

TRM-FA

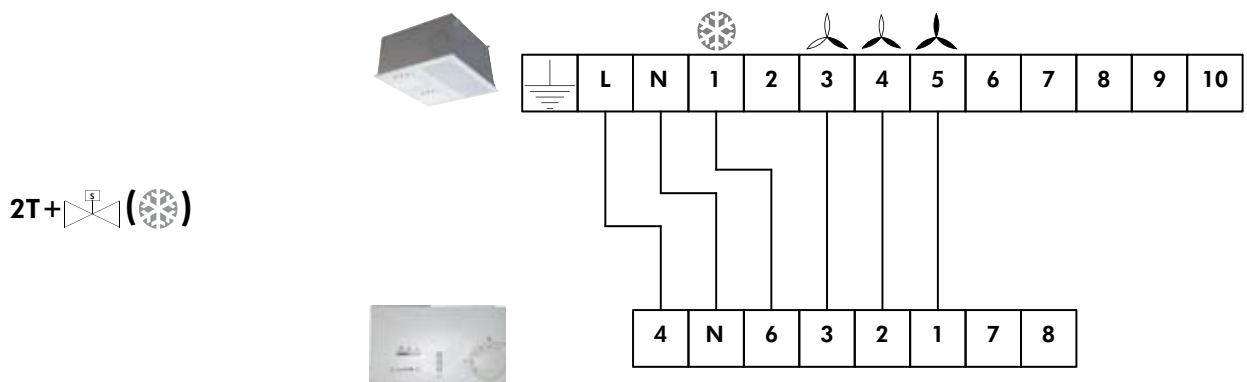

TRM-FA

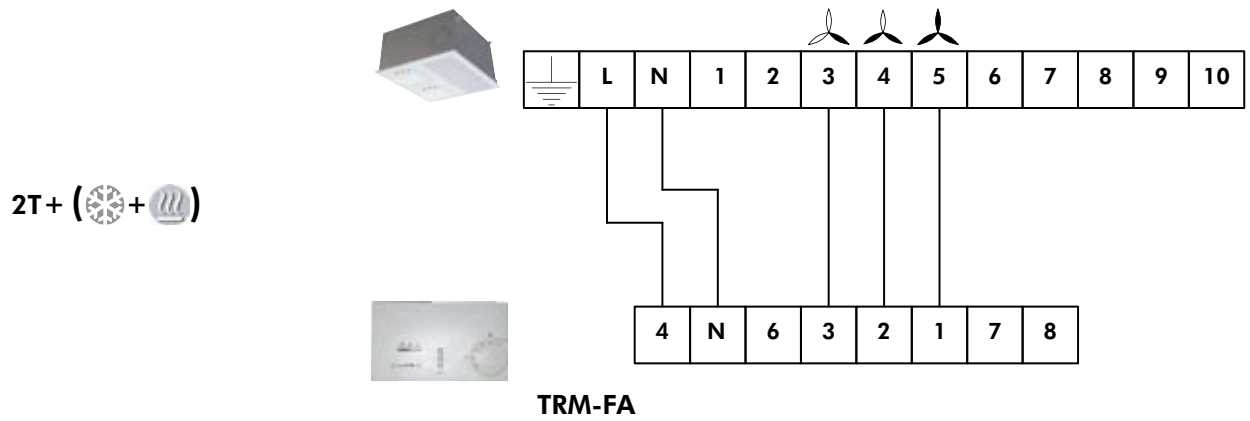
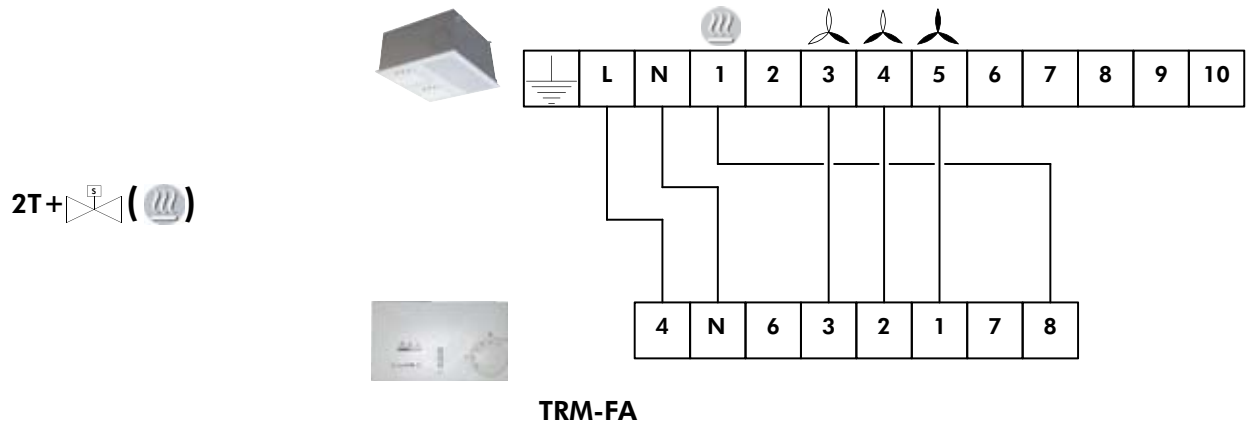

**MULTIDIRECTIONAL DIFFUSERS  
DIFFUSEURS ORIENTABLES  
RICHTUNGSUNABHÄNGIGE DIFFUSER  
DIFFUSORI ORIENTABILI  
DIFUSORES MULTIDIRECCIONALES**

**DIRECTION OF ROTATION  
SENS DE ROTATION  
DREHSINN  
SENSO DI ROTAZIONE  
SENTIDO DE GIRO**



KCO LN 60



KCO LN 90



KCO LN 120





**AIR JET REACH**  
**PORTÉE DU JET D’AIR**  
**REICHWEITE DES LUFTSTRAHLS**  
**PORTATA DEL GETTO D’ARIA**  
**ALCANCE DEL CHORRO DE AIRE**

**KCO LN 60**

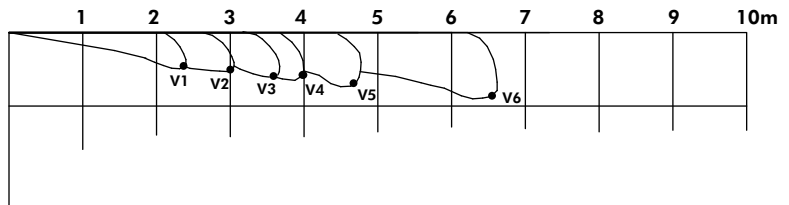
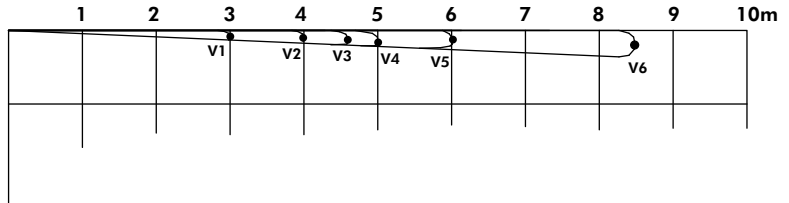
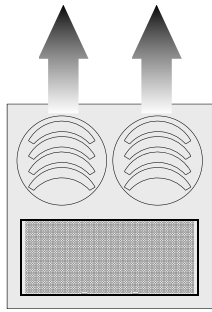

**KCO LN 90**

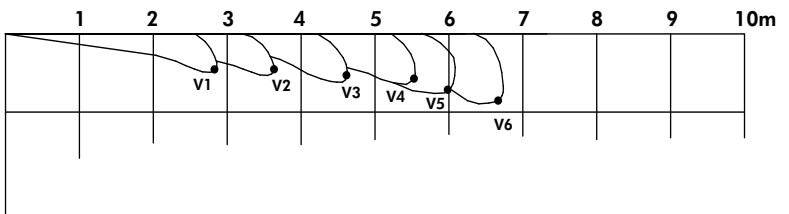
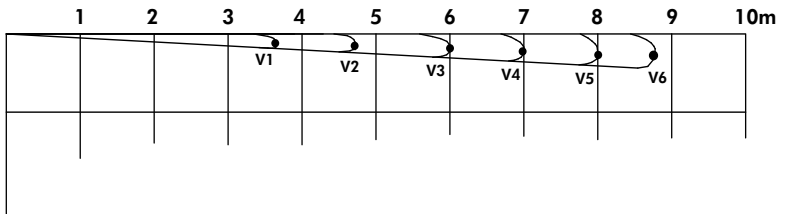
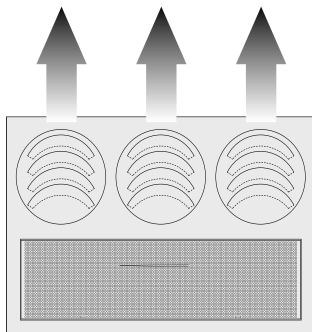

**KCO LN 120**

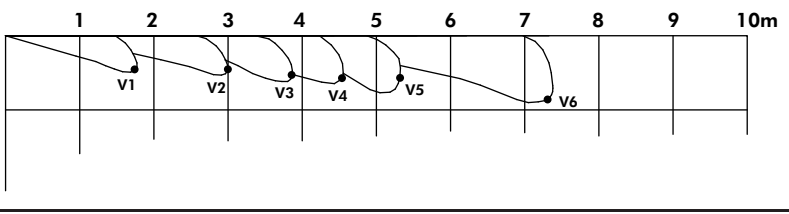
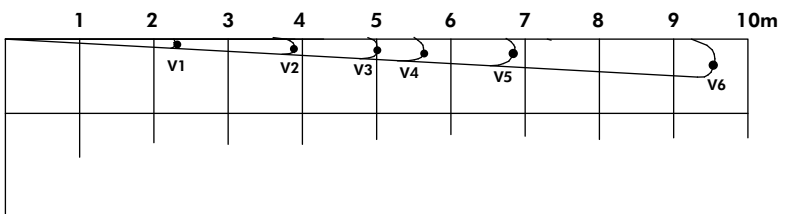
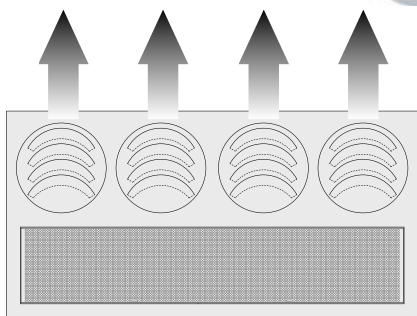



# EC Compliance declaration

Under our own responsibility, we declare that the product designated in this manual comply with the provisions of the EEC directives listed hereafter and with the national legislation into which these directives have been transposed.

## Déclaration CE de conformité

Nous déclarons sous notre responsabilité que les produits désignés dans la présente notice sont conformes aux dispositions des directives CEE énoncées ci- après et aux législations nationales les transposant.

## EG-Konformitätserklärung

Wir erklären in eigener Verantwortung, das die in der vorliegenden Beschreibung angegebenen Produkte den Bestimmungen der nachstehend erwähnten EG-Richtlinien und den nationalen Gesetzesvorschriften entsprechen, in denen diese Richtlinien umgesetzt sind.

## Dichiarazione CE di conformità

Dichiariamo, assumendone la responsabilità, che i prodotti descritti nel presente manuale sono conformi alle disposizioni delle direttive CEE di cui sott e alle lagislazionni nazionali che li recepiscono

## Declaración CE de conformidad

Declaramos, bajo nuestra responsabilidad, que los productos designados en este manual son conformes a las disposiciones de las directivas CEE enunciadas a continuacion, asi como a las legislaciones nacionales que las contemplan.

KCO LN 60 - 90 - 120  
REF:

LOW VOLTAGE DIRECTIVE (DBT) 73 / 23 / EEC AMENDED BY DIRECTIVE 2006 / 95 / EEC  
ELECTROMAGNETIC COMPATIBILITY DIRECTIVE 89 / 336 / EEC AMENDED BY DIRECTIVE 92 / 31 / EEC AND 93 / 68 / EEC  
PRESSURISE EQUIPMENT DIRECTIVE 97 / 23 / EEC  
SUB-MODULE A CATEGORY I

DIRECTIVE BASSE TENSION 2006 / 95 / C.E.E.  
DIRECTIVE COMPATIBILITE ELECTROMAGNETIQUE 89 / 336 / C.E.E. AMENDEE PAR DIRECTIVE 92 / 31 / C.E.E ET 93 / 68 / C.E.E  
DIRECTIVE DES EQUIPEMENTS SOUS PRESSION 97 / 23 C.E.E.  
SOUS-MODULE A CATEGORIE I

RICHTLINIE NIERDERSPANNUNG 2006 / 95 / EG  
RICHTLINIE ELEKTROMAGNETISCHE VERTRÄGLICHKEIT 89 / 336 / EG ABGEÄNDERT DURCH DIE RICHTLINIE 92 / 31 / EG UND 93 / 68 / EG  
RICHTLINIE FÜR AUSRÜSTUNGEN UNTER DRUCK 97 / 23 / EG  
UNTER MODUL A, KATEGORIE I

DIRETTIVA BASSA TENSIONE 2006 / 95 / CEE  
DIRETTIVA COMPATIBILITA ELETTRONAGNETICA 89 / 336 / CEE EMENDATA DALLA DIRETTIVA 92 / 31 / CEE E 93 / 68 / CEE  
DIRETTIVA DEGLI IMPIANTI SOTTO PRESSIONE 97 / 23 / CEE  
SOTTOMODULO A, CATEGORIA I

DIRETTIVA BAJA TENSION 2006 / 95 / CEE  
DIRETTIVA COMPATIBILIDAD ELECTROMAGNETICA 89 / 336 / CEE ENMENDADA POR LA DIRETTIVA 92 / 31 / CEE Y 93 / 68 / CEE  
DIRETTIVA DE LOS EQUIPOS A PRESION 97 / 23 / CEE  
BAJA MODULO A, CATEGORIA I

And that the following paragraphs of the harmonised standards have been applied.  
Et que les paragraphes suivants les normes harmonisées ont été appliqués.  
Und dass die folgenden Paragraphen der vereinheitlichten Normen Angewandt wurden.  
E che sono stati applicati i seguenti paragrafi delle norme armonizzate.  
Y que se han aplicado los siguientes apartados de las normas armonizadas.

EN 60 335-1  
EN 61 000-3-3

EN 60 335-2-40  
EN 55 014-1

EN 61 000-3-2  
EN 55 014-2

  
A Tillières Sur Avre  
27570 - FRANCE  
Le: 30/03/2007  
Franck Bailly  
Quality Manager  
ACE Industrie

*As part of our ongoing product improvement programme, our products are subject to change without prior notice. Non contractual photos.  
Dans un souci d'amélioration constante, nos produits peuvent être modifiés sans préavis. Photos non contractuelles.*

---

Your distributor/Votre agent commercial :

