

# WESTHERM 35 ÷ 110



**English**

**Français**

**Propeller fan unit heaters**

**Aérothermes hélicoïdes**

**IOM WTM-N.1GBF/05.06**

Part number / Code : **Q3NSTE830**

Supersedes / Annule et remplace : **IMW 300.0M/03.02**



# Table of Contents

<b>Introduction</b> .....	<b>p. 3</b>
<b>Safety Precautions</b> .....	<b>p. 3</b>
<b>Description</b> .....	<b>p. 4</b>
Inspection and storage .....	p. 4
Electrical data .....	p. 4
Operating limits .....	p. 4
<b>Dimensional Data and Weight of Standard Units</b> .....	<b>p. 5</b>
<b>Dimensional Data and Weight of Options</b> .....	<b>p. 7</b>
<b>Installation</b> .....	<b>p. 9</b>
Unit Handling .....	p. 9
Installation location .....	p. 9
Installation instructions .....	p. 10
Supply air throw .....	p. 11
<b>Water Connections</b> .....	<b>p. 12</b>
Water coil connections .....	p. 12
Water volume in the coils .....	p. 12
Water pressure drop .....	p. 13
<b>Electrical Connections</b> .....	<b>p. 14</b>
Unit connection .....	p. 14
Standard wiring diagram .....	p. 14
<b>Preliminary Checks Before Start-up</b> .....	<b>p. 15</b>
<b>Maintenance</b> .....	<b>p. 15</b>

# 1 - Introduction

The purpose of this manual is to provide the installation, start-up, operating and maintenance rules to the users of the propeller fan unit heaters.

It does not give a full description of all maintenance works assuring the long life and reliability of this type of equipment. Only the services of qualified personnel, member of a registered maintenance company, can guarantee a reliable and durable running of the unit.

# 2 - Safety Precautions

Before installing the unit, please read the following safety precautions carefully.



## Warning

Installation, operation and maintenance must be performed by qualified personnels who are familiar with local codes and regulations and experienced with this type of equipment.



## Warning

All field wiring must be installed in accordance with the national wiring regulations.



## Warning

Ensure the rated voltage of the unit corresponds to the name plate before carrying out wiring according to the supplied wiring diagram.



## Warning

The unit must be GROUNDED to prevent possible hazards due to insulation failures.



## Warning

All wiring must not touch the heat source or any moving parts of fan motor.



## Warning

Confirm the unit is switched OFF before installing or servicing the unit.



## Caution

Handling of the unit must be done by using the systems designed to support its weight.



## Caution

It is forbidden to undertake any work on electrical components of the unit before disconnecting the power supply.



## Caution

It is forbidden to undertake any work on electrical components of the unit, if there is presence of water and humidity.



## Caution

When undertaking water connection, make sure that any foreign matters will not be introduced into water piping.

**The manufacturer warranty will not be applied, if all installation instructions stated in this manual have not been followed.**

## 3 - Description

### 3.1 - Inspection and Storage

When the equipment is received, all items must be carefully checked against the bill of lading to be sure all crates and cartons have been received. The units are shipped in carton. Inspect all units for visible or concealed damages.

**In case of deterioration, formulate the precise reserves on the transport document and send immediately a**

**registered letter to the forwarder, mentioning clearly the occurred damages and a copy of the letter to the manufacturer or its representative.**

Do not stand or transport the unit on its end. Temporary storage must be indoor, completely sheltered from rain, snow, etc. Change in the weather (high and low temperatures) should not damage the unit. Excessively high temperature (60 °C or more) may deteriorate certain plastic materials and cause permanent damages. In addition, some electric components may not operate correctly.

### 3.2 - Electrical Data

#### Standard motor data

Sizes	Speed (rpm)	Voltage (V - Ph - Hz)	Power (kW)	Current (A)	Insul. class	IP index
35	900	230-1-50	0.022	0.25	F	54
	900	230/400-3-50	0.037	0.46 / 0.27	F	54
	1400	230-1-50	0.06	0.6	F	54
	1400	230/400-3-50	0.038	0.4 / 0.23	F	54
45	900	230/400-3-50	0.25	1.44 / 0.83	F	55
	1400	230/400-3-50	0.25	1.41 / 0.81	F	55
	1400/900	400-3-50	0.4 / 0.12	1.38 / 0.51	F	55
50	900	230/400-3-50	0.25	1.44 / 0.83	F	55
	1400	230/400-3-50	0.55	2.46 / 1.42	F	55
	1400/900	400-3-50	0.55 / 0.18	1.62 / 0.73	F	55
55	900	230/400-3-50	0.25	1.44 / 0.83	F	55
	1400	230/400-3-50	0.55	2.46 / 1.42	F	55
	1400/900	400-3-50	0.55 / 0.18	1.62 / 0.73	F	55
65	900	230/400-3-50	0.37	2.08 / 1.19	F	55
	1400	230/400-3-50	0.75	3.22 / 1.86	F	55
	1400/900	400-3-50	1.1 / 0.38	2.65 / 1.35	F	55
70	700	230/400-3-50	0.37	2.00 / 1.16	F	55
	900	230/400-3-50	0.75	3.65 / 2.1	F	55
	900/700	400-3-50	0.75 / 0.37	2.09 / 1.32	B	54
110 *	900	230/400-3-50	0.25	1.44 / 0.83	F	55
	1400	230/400-3-50	0.55	2.46 / 1.42	F	55
	1400/900	400-3-50	0.55 / 0.18	1.62 / 0.73	F	55

\* Equipped with 2 motors (2 overload thermal protections are required).

### 3.3 - Operating Limits

#### Unit in operation with hot water circulation

Water piping system	Maximum operating pressure	10 bar
	Minimum entering temperature	+ 45 °C
	Maximum entering temperature	+ 120 °C
Room air temperature	Minimum temperature	- 15 °C
	Maximum temperature	+ 30 °C
Supply voltage *	230 V ± 10 % / 1 ph / 50 Hz or 400 V ± 10 % / 3 ph / 50 Hz	

\* Single phase on size 35 only.

# 4 - Dimensional Data and Weight of Standard Units

## 4.1 - Vertical Arrangement

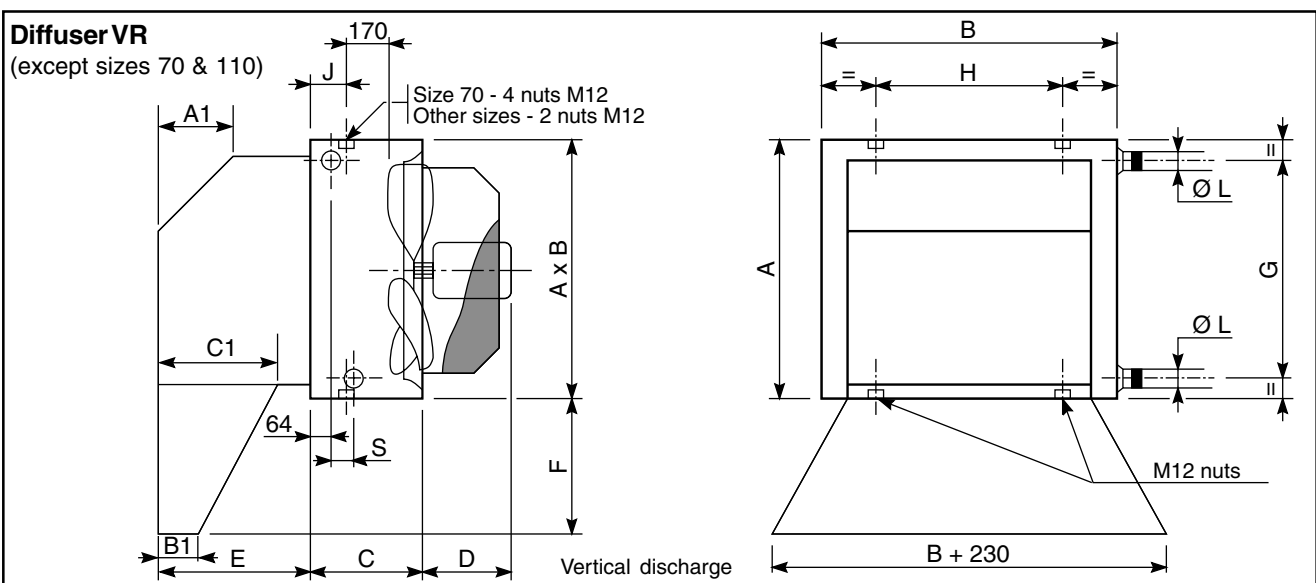
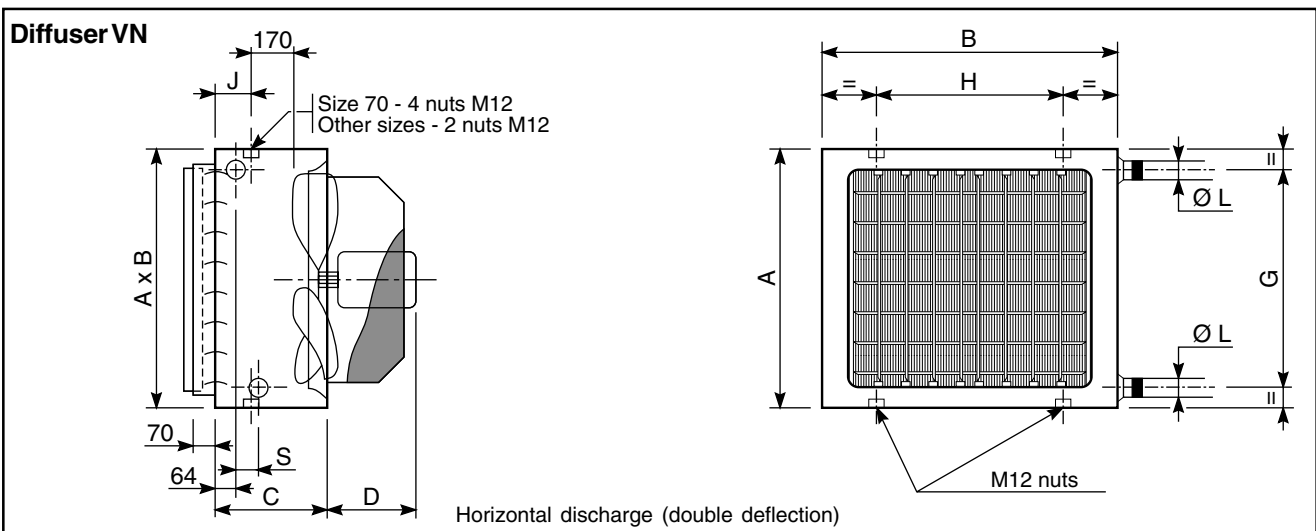
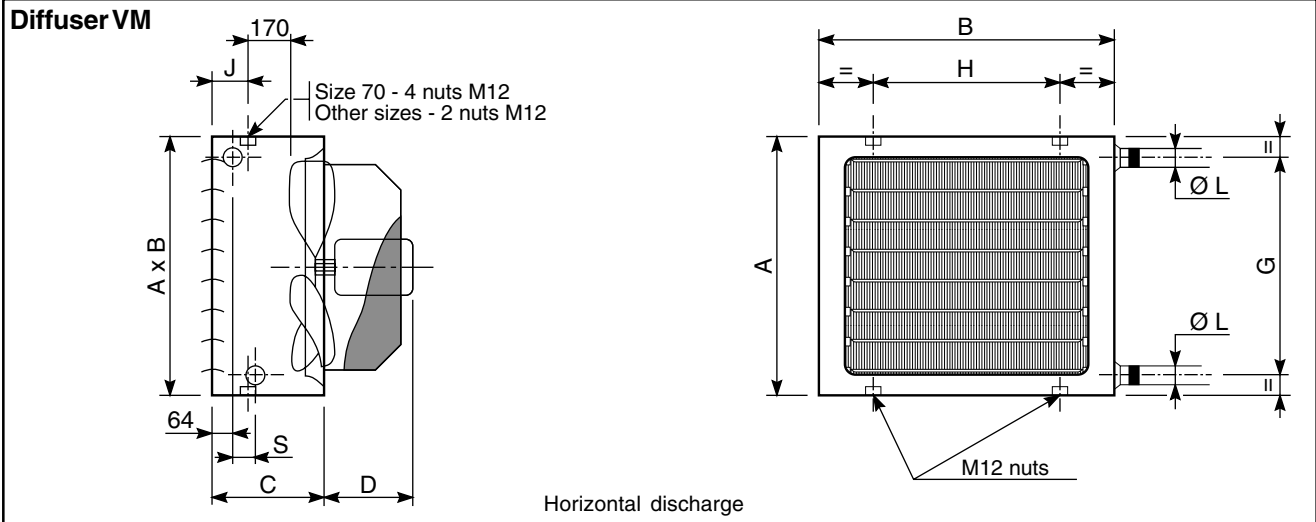

# 4 - Dimensional Data and Weight of Standard Units (cont'd)

## 4.2 - Horizontal Arrangement

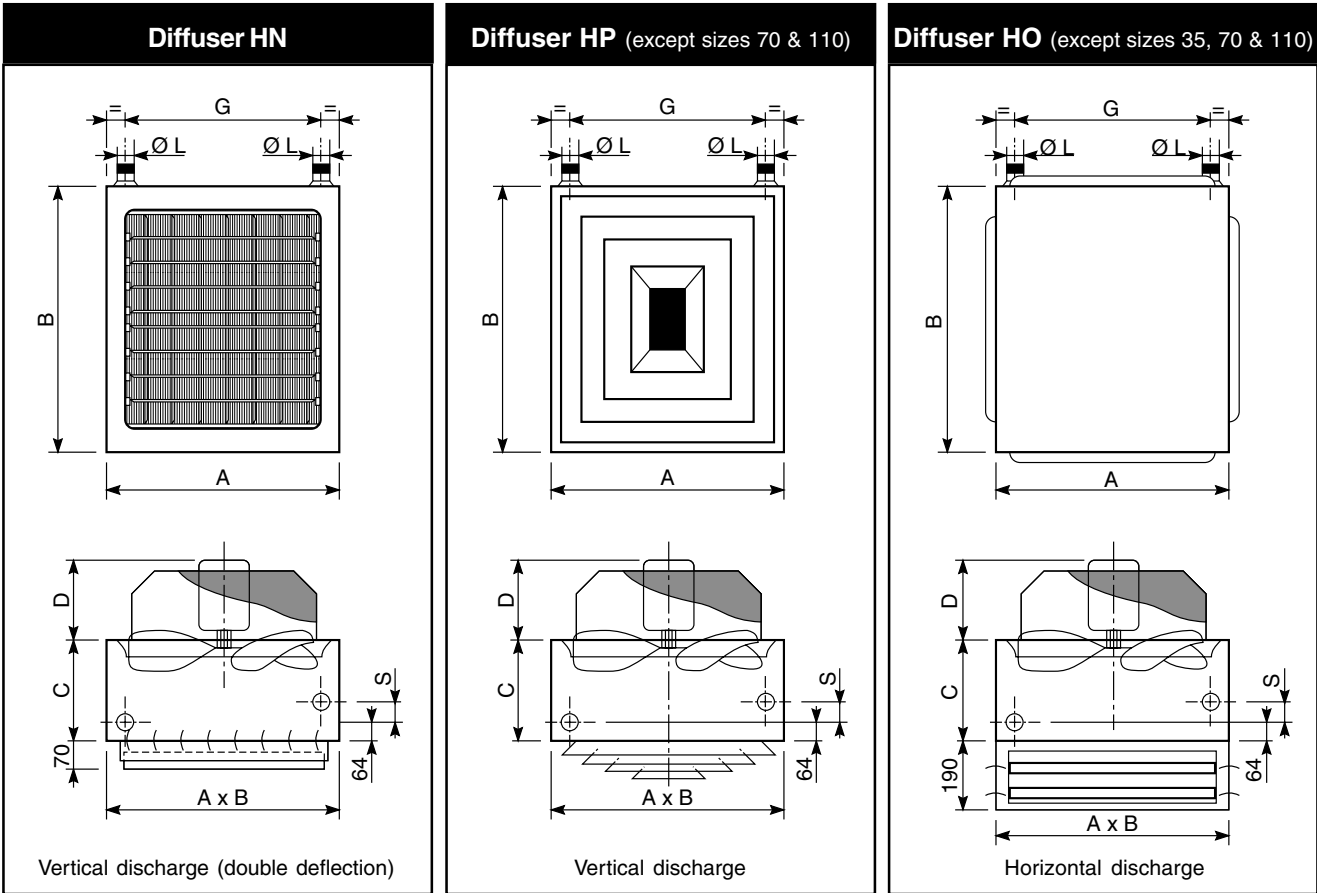

Dimensions (mm)

Sizes	35	45	50	55	65	70	110
A	440	560	560	680	800	920	680
B	550	670	790	790	910	990	1580
C	300	300	300	300	300	440	300
D	245	275	275	275	295	295	275
E	300	400	400	400	400	-	-
F	270	370	370	370	370	-	-
G	330	450	450	570	690	810	570
H	320	440	560	560	680	700	1350
J	124	124	124	124	124	45	124
L	See table below						
S	30	60	60	60	60	60	60
A1	175	175	175	175	175	-	-
B1	98	160	200	249	249	-	-
C1	260	360	360	347	347	-	-

Weight (kg)

Sizes	Operating weight
351	20.0
352	22.5
353	25.0
451	32.5
452	37.5
453	42.0
501	41.0
502	47.0
503	54.0
551	45.5
552	52.0
553	58.5
651	56.0
652	65.0
653	74.0
701	82.0
702	92.0
703	103.0
1101	91.0
1102	104.0
1103	117.0

Water connection sizes (Ø L)

Sizes	Cu/Alu coils Number of rows			Cupro-nickel/Alu coils Number of rows		
	1	2	3	1	2	3
35	20/27	20/27	20/27	15/21	15/21	15/21
45	20/27	26/34	26/34	15/21	33/42	33/42
50	20/27	26/34	26/34	15/21	33/42	33/42
55	20/27	26/34	26/34	15/21	33/42	33/42
65	26/34	26/34	33/42	40/49	40/49	40/49
70	33/42	33/42	33/42	40/49	40/49	40/49
110	26/34	33/42	33/42	40/49	40/49	40/49

# 5 - Dimensional Data and Weight of Options

## Component description

- V : Vertical mounting unit heater.
- H : Horizontal mounting unit heater.
- A : Cubic inlet casing for matching other accessories on 3 faces.
- B : Mixing box with dampers.
- C : Horizontal non-return shutter.
- D : Vertical non-return shutter.
- E : Filter box with flat-bank filter.
- F : External weatherproof louvre with bird guard.
- G : Duct.
- J : Mixing box with adjustable shutter and wire mesh guard.
- K : Return air plenum with wire mesh guard.
- L : Flat-bank filter for casing A.
- Z : Roof air inlet with bird guard and seal ring, to be mounted by others.

## Standard arrangements

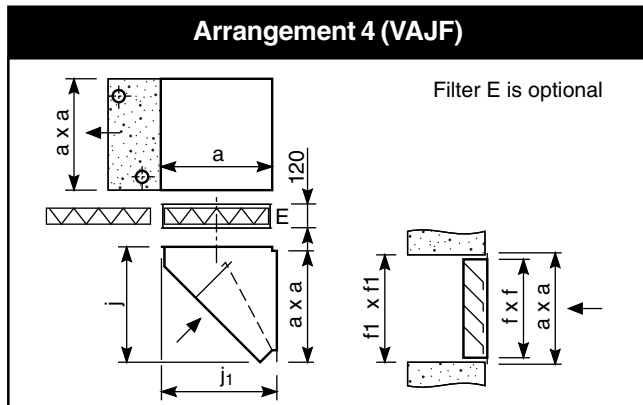
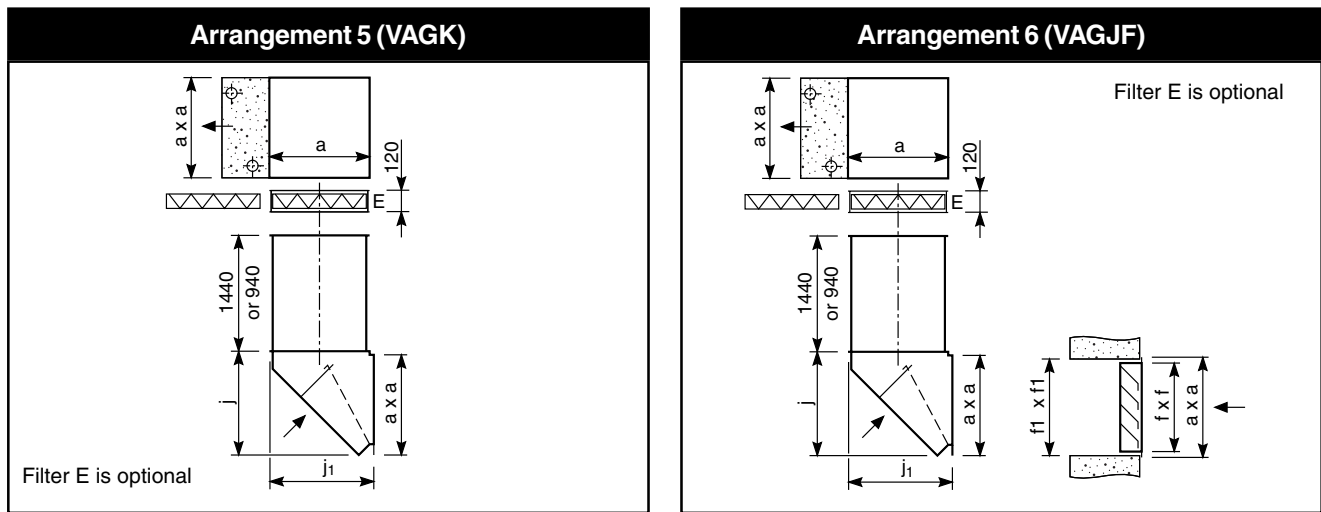
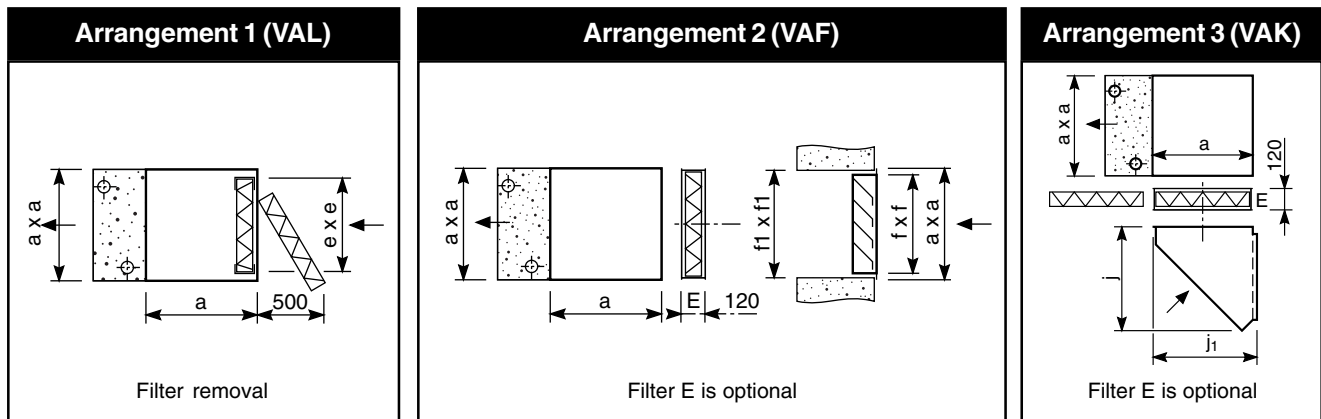

Dimensions (mm)

Sizes	35	45	50	55	65	70	110
a	440	560	560	680	800	800	680
e	370	490	490	610	730	730	610
f	382	502	502	622	742	742	622
f <sub>1</sub>	392	512	512	632	752	752	632
h	720	900	900	1080	1280	1280	1080 *
h <sub>2</sub>	190	230	230	275	310	310	275
h <sub>4</sub>	960	1080	1080	1200	1320	1320	1200
j	480	600	600	720	840	840	720
j <sub>1</sub>	460	580	580	700	820	820	700

Note : The size 110 is equipped with 2 accessory sets of the size 55. (\* 1080 x 1870).

The filter box E allows a filter removal from one of the four sides.

# 5 - Dimensional Data and Weight of Options (cont'd)

## Standard arrangements

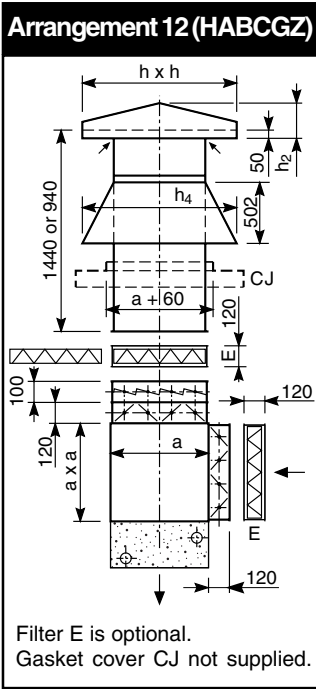
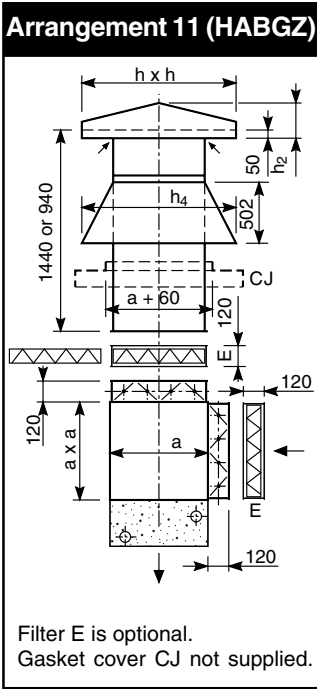
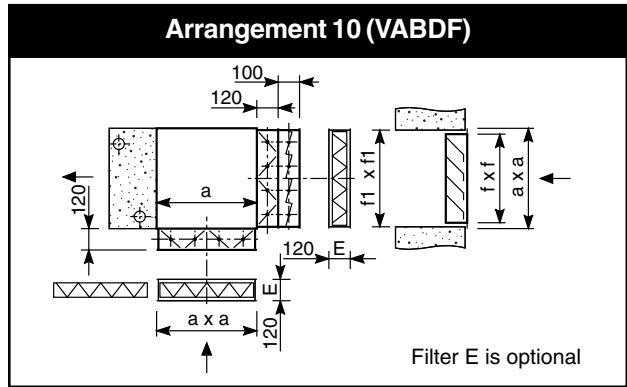
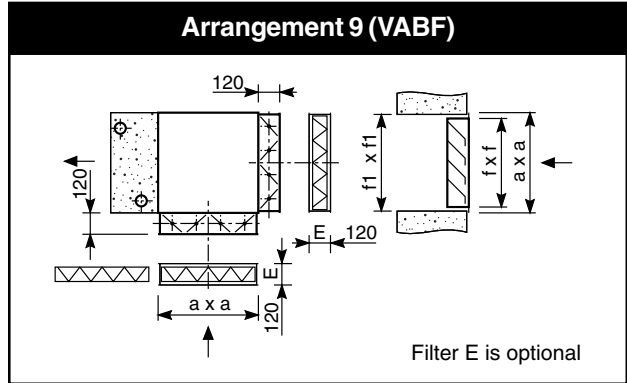
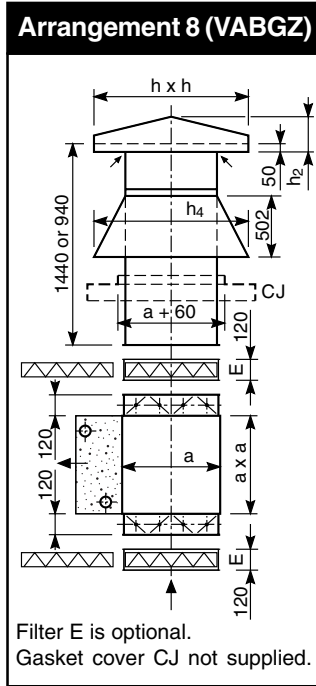
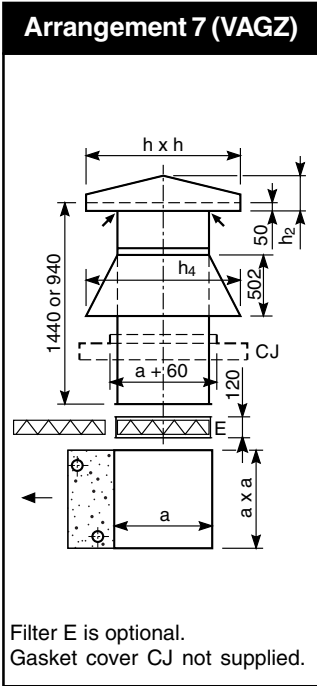

### Position of damper control shaft

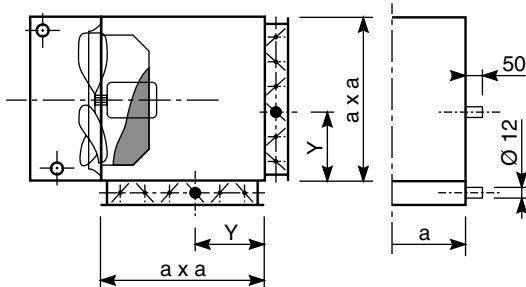

### Weight (kg)

Sizes	35	45	50	55	65	70	110
<b>Optional arrangements</b>	1	10.0	15.0	15.0	22.0	29.0	44.0
	2	11.0	17.0	17.0	24.0	31.5	48.0
	3	17.0	25.5	25.5	35.0	46.5	70.0
	4	20.0	30.0	30.0	41.0	54.0	82.0
	5	37.0	51.5	51.5	67.0	84.5	134.0
	6	40.0	56.0	56.0	73.0	92.0	146.0
	7	57.0	75.5	75.5	95.0	117.0	190.0
	8	67.0	88.0	88.0	111.0	137.0	222.0
	9	21.0	29.5	29.5	40.0	51.5	80.0
	10	25.0	34.5	34.5	47.0	59.5	94.0
	11	67.0	88.0	88.0	111.0	137.0	222.0
	12	71.0	93.0	93.0	118.0	145.0	236.0
<b>Diffusers</b>	N	3.0	4.5	5.5	6.5	7.5	13.0
	O	-	10.0	11.0	12.5	16.0	-
	P	1.5	2.5	3.0	3.5	5.0	-
	R	12.0	17.0	18.5	20.0	23.0	-

**Note :** The size 110 is equipped with 2 accessory sets of the size 55.

Sizes	35	45	50	55	65	70	110
<b>Y</b>	173.5	280.0	280.0	292.5	400.0	400.0	292.5



# 6 - Installation

## 6.1 - Unit Handling

Be careful to avoid rough handling on the unit. **Do not lift the unit by the motor support or by the coil connecting headers.** Use a lifting truck to facilitate the unit installation.



### Warning

Sharp edges and coil surfaces are a potential hazard. Avoid contact with them.

## 6.2 - Installation Location

1. The units are designed to be installed at high position.
2. Install the unit in a position having sufficient strength to carry the weight of the unit.
3. In accordance with the number of units which are to be installed and for a maximum comfort, the air stream will be pointed to maximum heat loss area (small area premises) - fig.1 - or oriented in order to obtain a total homogeneity of temperatures - fig.2 - (tertiary buildings and large volumes).



### Warning

Do not install the unit in a machinery shop or kitchen where vapour from oil or its mist flows into the unit.

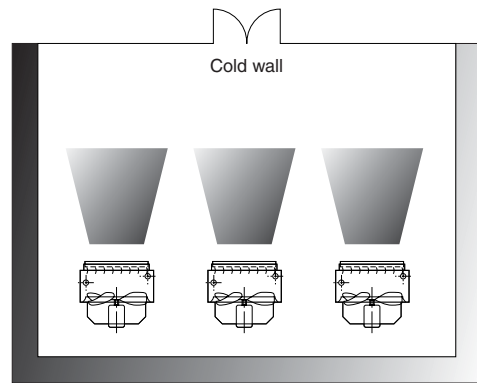
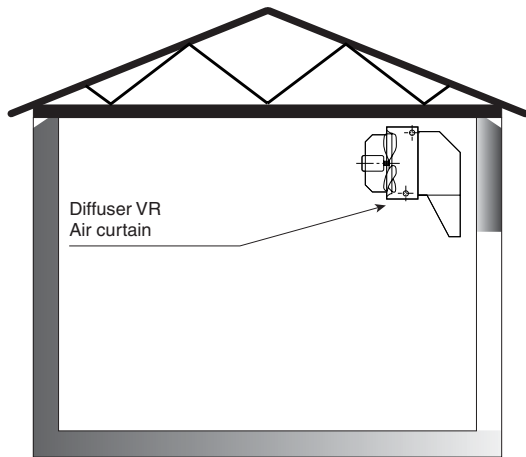

Figure 1

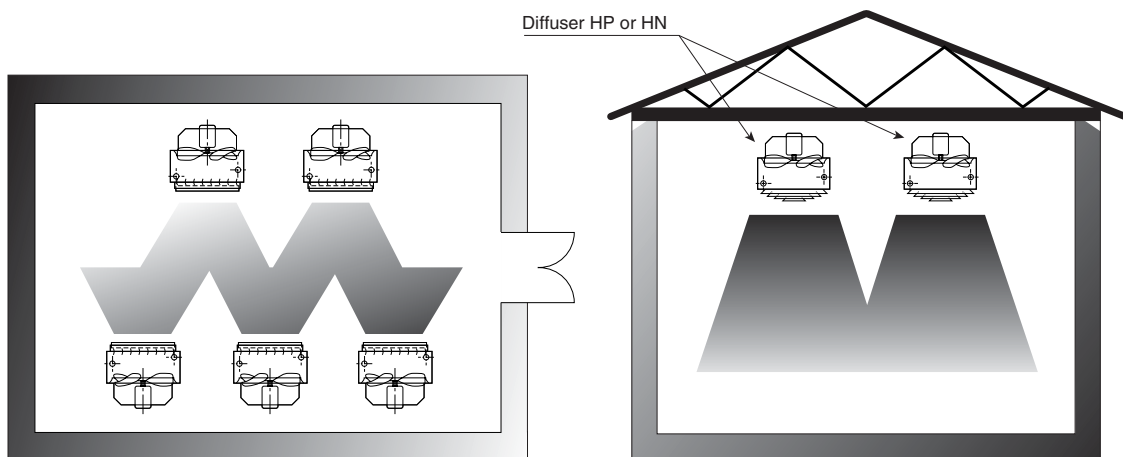

Figure 2

## 6 - Installation (cont'd)

### 6.3 - Installation Instructions

1. Unpack the unit and install the fixing brackets on it (see drawings below).
2. The unit must be installed with a minimum distance of 150 mm between motor and wall, so that air flow is not impeded and removal of fan motor assembly can be easily realized (see drawing A).
3. For vertical mounting unit, fix it directly to the suitable supports or hang it to the ceiling by threaded rods or strengthened screws supplied by the installer (see drawings A & B).
4. The ceiling units with down flow air discharge must be suspended via 4 hangers fixed onto fixing brackets

located on the sides of the unit (see drawing C).

5. Secure the unit in its final position and **level it with a spirit level** to assure proper operation.

**Remark :** the fixing accessories shown such as supports, rods or brackets are not supplied by manufacturer.



#### Warning

It is highly recommended, or even compulsory in certain case, to fit the unit with the optional fan guard. Make sure the unit is in conformity with applicable safety regulations.

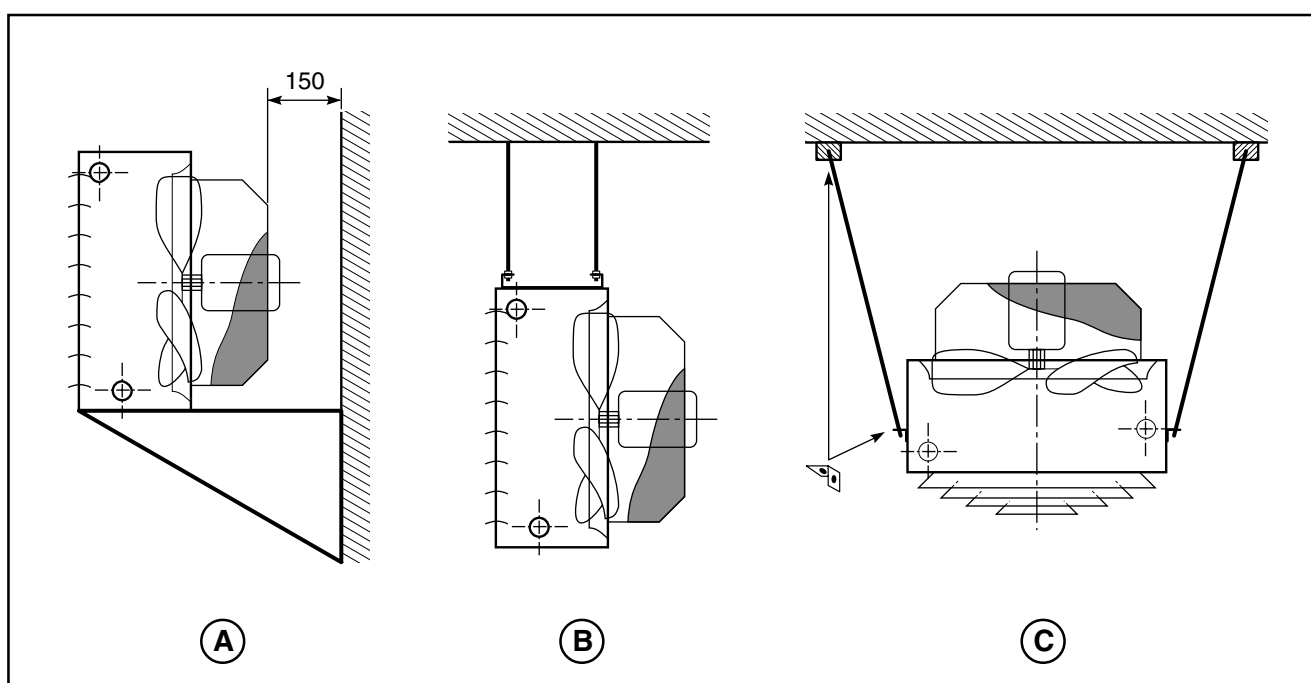

## 6 - Installation (cont'd)

### 6.4 - Supply Air Throw (m)

The air throw of a propeller fan unit heater is the distance between the unit and the points where the air velocity is no longer felt by the human body (approx. 0.2 m/sec.).

The air throw allows the units to be installed in the room.

The table below gives the air throw of a unit in relation to model and

supply diffuser, for a supply air temperature difference of 15 °C.

For other temperature differences, use the correction factor.

#### Correction factor

Temp. difference	10 °C	15 °C	20 °C	30 °C	40 °C
Factor	1.28	1.00	0.90	0.70	0.60

Sizes		35		45		50		55		65		70		110	
Fan speed		900	1400	900	1400	900	1400	900	1400	900	1400	700	900	900	1400
VM	L	8.0	12.0	10.0	14.0	12.0	16.0	14.0	18.0	16.0	20.0	16.0	20.0	14.0	18.0
	H	3.0	3.0	4.0	5.0	4.0	5.0	4.0	5.0	4.0	5.0	4.0	5.0	4.0	5.0
VN	L	8.0	12.0	10.0	14.0	12.0	16.0	14.0	18.0	16.0	20.0	16.0	20.0	14.0	18.0
	H	3.0	3.0	4.0	5.0	4.0	5.0	4.0	5.0	4.0	5.0	4.0	5.0	4.0	5.0
HN	D	7.0	10.0	9.0	12.0	11.0	14.0	12.0	16.0	14.0	18.0	14.0	18.0	12.0	16.0
	G*	4.0	4.5	4.5	5.0	4.5	5.5	5.0	6.0	5.5	6.5	5.5	6.5	5.0	6.0
HO	S	-	-	2.5 to 4.0		2.5 to 4.0		2.5 to 4.0		2.5 to 4.0		-	-	-	-
	L	-	-	6.0	8.0	6.5 to 8.5		7.0	9.0	7.5	9.0	-	-	-	-
HP	G	4.0	4.5	4.5	5.0	4.5	5.5	5.0	6.0	5.5	6.5	-	-	-	-
	D	7.0	10.0	9.0	12.0	11.0	14.0	12.0	16.0	14.0	18.0	-	-	-	-
VR	V	3.0	4.0	3.5	4.5	3.5	5.0	4.0	5.0	3.0	4.0	-	-	-	-
	X	3.0	4.0	4.0	5.0	4.5	5.5	5.0	6.0	5.5	6.5	-	-	-	-

\* Air throw of diffuser HN can be increased by changing the shutter position.

#### Vertical arrangement

Diffuser VR (air curtain)

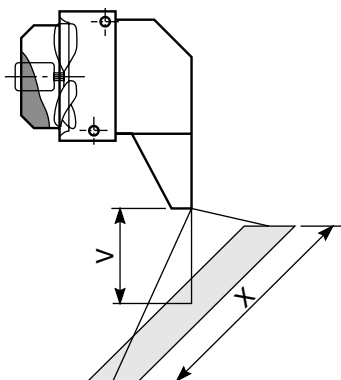

Diffuser VM, VN

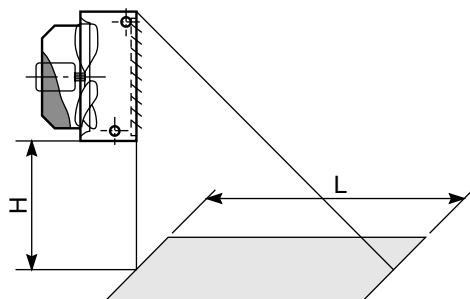

#### Horizontal arrangement

Diffuser HO

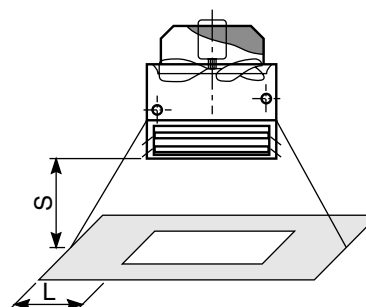

Diffuser HP, HN

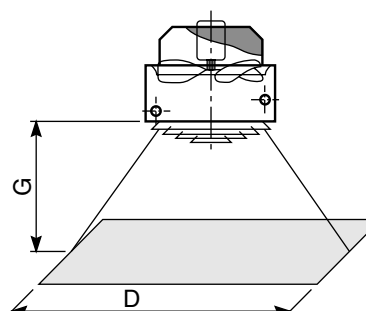

## 7 - Water Connections

### 7.1 - Water Coil Connections

Each water coil is equipped with headers having male threaded type connection on water supply and water return (see section "Dimensional data and weight of standard units" for header connection sizes).

Air vent must be installed at highest point of the water piping.

To ensure an optimum heat transfer efficiency, connections of water supply and return should be arranged in such a way that a counter flow configuration between air and water is obtained.

Flexible hoses are recommended for coil connections in order to ensure a free volume expansion of water pipings

and to avoid mechanical stresses on the units. Tighten normally the water connections. Note that an excessive tightening can cause too strong material stresses at the time of significant temperature changes.

All water lines should be insulated to prevent sweating and heat loss.



#### Warning

To avoid any damage on coil, use two spanners to tighten the water pipe fittings on each header.

This non-observation leads to the cancellation of the warranty in case of damages caused to the coil.

### 7.2 - Water Volume in the Coils

Models	Water volume (dm <sup>3</sup> )
351	1.8
352	3.9
353	5.8
451	3.0
452	6.5
453	9.5
501	3.6
502	7.7
503	11.3
551	4.2
552	9.0
553	13.2

Models	Water volume (dm <sup>3</sup> )
651	8.0
652	14.0
653	20.0
701	10.4
702	18.4
703	27.2
1101	11.0
1102	20.0
1103	29.0

# 7 - Water Connections (cont'd)

## 7.3 - Water Pressure Drop

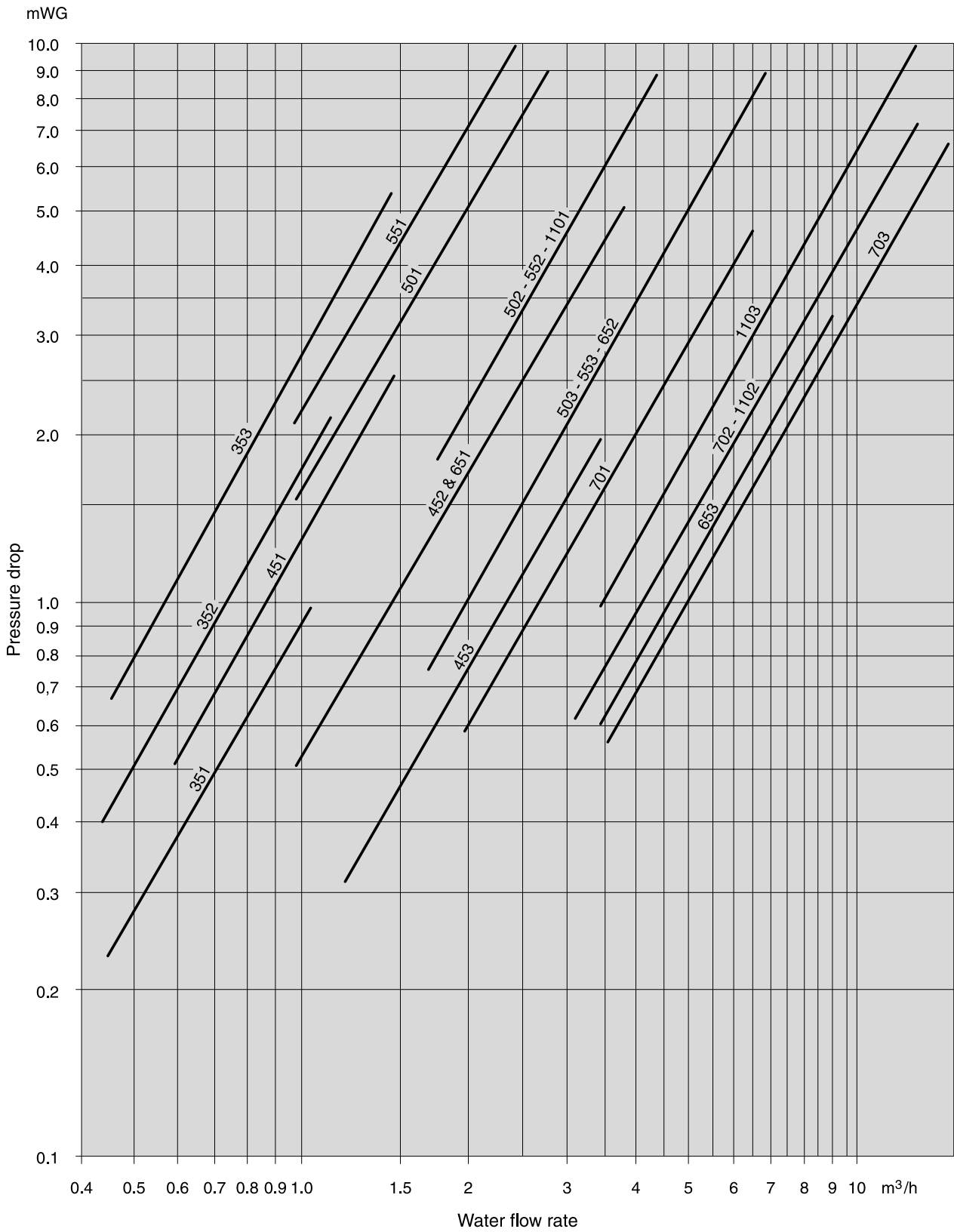

## 8 - Electrical Connections

### 8.1 - Unit Connection

Before undertaking any electrical connection, make sure that the fan motor is suitable for electrical power supply. All wiring must be done in accordance with applicable electrical codes and regulations.

#### **Earthing of unit is imperative.**

The manufacturer or its representative will not be held responsible for accidents caused by incorrect or non-existing earthing.

Concerning the unit mounted in horizontal arrangement (vertical discharge), the maximum allowable temperature on the motor is 40 °C. If the fan is switched off, it is important to check that hot water will not circulate in the coil. If this case may happen, it is recommended to use a control valve on the coil.

### 8.2 - Standard Wiring Diagram

**To perform electrical wiring of fan motor, please refer to wiring diagram supplied in the motor terminal box.**



#### **Warning**

The propeller fan unit heaters must be controlled by a contactor equipped with a thermal protection that protects the motor against any accidental excess currents.

## 9 - Preliminary Checks Before Start-up

1. Make sure that system piping has been cleaned and all the air has been purged, before starting up the unit.
2. Ensure that air filter (optional) is clean and properly installed.
3. Make certain that fan rotates freely.
4. Make sure that all water and electrical connections are properly tightened.

## 10 - Maintenance

It is recommended to proceed to the following maintenance works in order to ensure a good operation of the unit.



### Caution

Before performing any maintenance operation, disconnect the unit main power supply.

### 10.1 - Air Filter (optional)

Filters should be frequently cleaned to avoid clogging. They should be inspected every 3 or 4 months under normal operating conditions and be replaced if necessary (see drawings below for the filter removal).

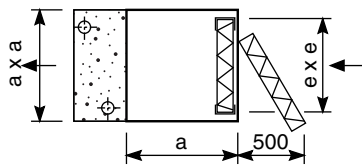

VAL arrangement - Filter removal

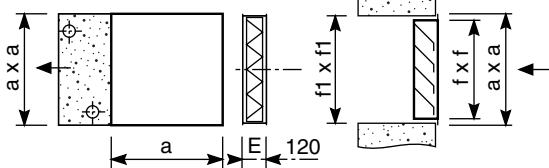

VAF arrangement - The filter box E allows filter removal from one of the four sides.

### 10.2 - Coils

Check that coil fins are not clogged or damaged.

To avoid mouldiness of coils caused by an accumulation of fine dusts, it is recommended to clean them frequently. If necessary, comb the coil fins with an appropriate tool.

Care must be taken not to damage the fins while cleaning them.

### 10.3 - Fan-Motor Assembly

There is no particular maintenance on fan motor assembly. However, during periodic maintenance, check that fan wheel rotates freely without any friction.

### 10.4 - Electrical Connections

Re-tighten periodically the electrical connections.

### 10.5 - Water Piping System

Once a year, drain the piping system and check the furring-up of the pipes.



### Caution

It is not the manufacturer's policy to make recommendations in terms of water treatment (please contact a specialised water treatment company).

However, given the critical nature of this subject, particular care should be taken to ensure that, if treatment is required, it works effectively.

Using untreated or unsuitable water leads to excessive clogging inside the coil tubes (earth and mud deposits, corrosion, etc.) with major consequences on the thermal efficiency of the unit and irreversible damage to the equipment.

The manufacturer and its representative decline all responsibility in the event of untreated or incorrectly treated water being used.



### Caution

If the water pipes are exposed to temperatures below 0 °C, take the necessary precautions (draining, antifreeze, etc.) to avoid the coils freezing. Adding antifreeze to the circuit reduces the unit's performance (if necessary, please contact our sales network).

*As part of our ongoing product improvement programme, our products are subject to change without prior notice. Non contractual photos.  
Dans un souci d'amélioration constante, nos produits peuvent être modifiés sans préavis. Photos non contractuelles.*

---

