

▶ Air Cooled Water Chillers & Air-to-Water Reverse Cycle Heat Pumps

MQL/MQH 4 to 17



4.5 to 16.5 kW



4.6 to 18.4 kW



Technical Brochure

TM MQLH-A.2GB

Date : July 2006

Supersedes : TM MQLH-A.1GB/09.05

Technical Features

General

The **MQL air cooled water chillers and MQH air-to-water reverse cycle heat pumps** have been designed to operate with HFC 407C refrigerant. They are suitable for small capacity air conditioning applications required in the residential or small tertiary sectors.

Thanks to the microprocessor new features, such as **auto-adaptive set point** at different load and water volume conditions, the MQL and MQH can operate **without water tank**. Therefore, the minimum water volume required is **3.5 litres/kW**. However, 15 litre external water tank can be supplied as an option.

The "Plug and Play" concept has been implemented in each MQL/MQH unit, thanks to the **BMS compatible microprocessor-based control system** with ModBus protocol RS485 and to the **3-speed integrated circulating pump** supplied as standard.

The MQL/MQH units are available in **7 sizes** (4, 6, 8, 10, 12, 15 and 17) covering a nominal cooling capacity range from 4.5 to 16.5 kW and a nominal heating capacity range from 4.6 to 18.4 kW.

Reference standards

The following applies to all the sizes belonging to the MQL/MQH units :

- Performance test EN 12055
- Machine Directive EEC 89/392
- Low Voltage Directive EEC 73/23
- Electromagnetic Compatibility Directive EN 50081-1 & EN 50082-2

Cabinet and structure

The unit cabinet and structure are made of heavy gauge galvanized steel coated with polyester powder based painting (RAL 9001). All parts of the structure are fastened totally with non-corrosive screws and bolts.

Compressors

The MQL/MQH 4 & 6 are equipped with rotative compressor suitable for single phase power supply, MQL/MQH 8 & 10 with scroll compressor suitable for single phase or 3-phase power supply and MQL/MQH 12 to 17 with scroll compressor suitable for 3-phase power supply.

The compressor of each model is mounted on rubber vibration isolators in order to eliminate noise and vibration transmissions.

All compressors have direct on line starting. The compressor motors are cooled by refrigerant gas and are equipped with overload protection.

Refrigerant/water heat exchanger

Stainless steel plate heat exchanger insulated with closed cell synthetic foam. Exchanger is protected by an antifreeze electrical heater.

Maximum working pressure is 3 bar at water side and 30 bar at refrigerant side.

Water connections are of 1" female gas threaded type.

Air/refrigerant heat exchanger

Air cooled coil composed of seamless copper tubes, arranged in staggered rows, mechanically expanded into corrugated aluminium fins. Coil is protected by a plastic grille.

Fans

MQL/MQH 4 to 8 are equipped with one fan and MQL/MQH 10 to 17 with two fans. Fans are of direct drive axial type and are equipped with a protective plastic grille.

Variable speed type electrical motors have IP 44 grade and are equipped with thermal protection.

Pressostatic fan speed controller can be supplied as an option to allow the unit to operate with external air temperature down to -10 °C in cooling mode.

Refrigerant circuit

All refrigerant components are shown in the functional diagrams illustrated in the next pages, section "Refrigerant flow diagrams".

Power and control panel

Electrical box is complete with all components necessary for a safe and correct operation of the unit : phase monitor (for 3-phase units only), compressor relay, main fuses, main disconnect device, capacitors, terminals and transformer.

Each unit is supplied with a compact microprocessor based control, easy to use, with special algorithm for cooling and heating capacity management according to different load and ambient conditions :

- auto-adaptive cooling and heating set point,
- fan motor variable speed control,
- pump management both in running or in standby condition,
- evaporator protection for antifreeze and for high inlet water temperature in cooling mode,
- BMS compatibility (ModBus protocol RS485),
- remote start-stop contact,
- remote cool-heat mode selection contact,
- external keypad device (optional).

Safety and control devices

Each unit is complete with the following safety and control devices :

Safety :

- Fan motor overload protection.
- Compressor motor overload protection.
- Water differential pressure switch.
- High discharge pressure switch.
- Low suction pressure switch.
- Evaporator antifreeze electrical heater.
- Crankcase heater (sizes 8 to 17 only).

Control :

- Inlet water temperature sensor.
- Outlet water temperature sensor.
- Coil temperature sensor.
- Discharge pressure transducer (included in the optional pressostatic fan speed controller).

Accessories and options

- Coil with blue fins.
- Water filter.
- No pump kit.
- 15 litre external water tank.
- Soft starter (single phase units only).
- Pressostatic fan speed controller.
- ModBus serial interface.
- Remote keypad.

Controls

User interface

The interface, composed of controller's front panel, allows the user to carry out all the operations related to the use of the controller, in particular :

- to set the operation mode,
- to manage alarms,
- to check the state of resources.

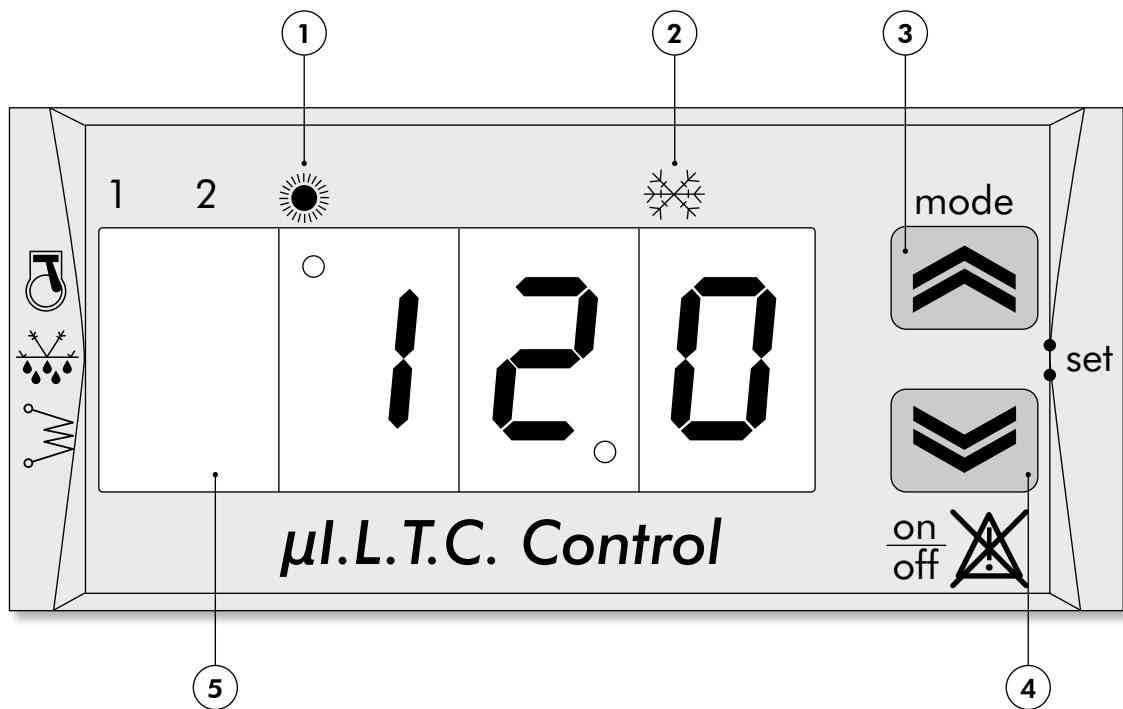

Leds	
1	Heating mode display (MQH version)
2	Cooling mode display
3	Operating mode selection
4	Unit ON/OFF ; Alarm restoration
5	Display

Refrigerant Flow Diagrams

MQH 4 to 8

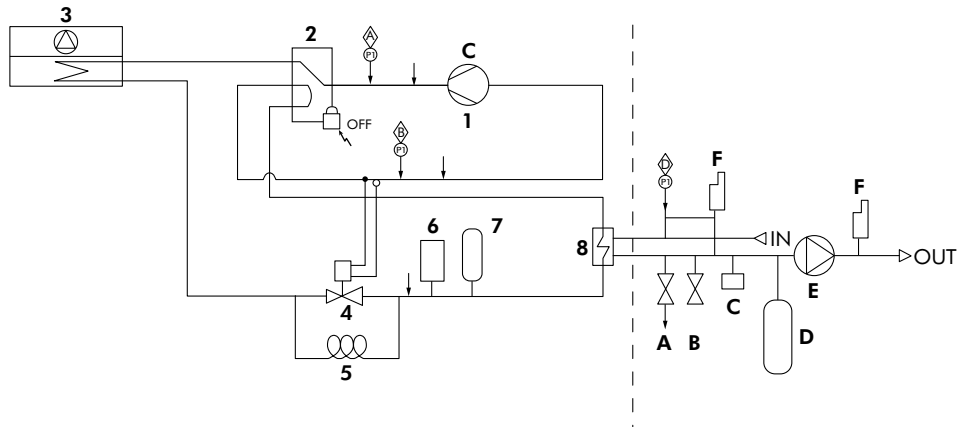

REFRIGERANT CIRCUIT	HYDRAULIC CIRCUIT
1 Compressor	A Drain valve
2 4-way valve	B Safety valve
3 Coil + Fan	C Water manometer
4 Biflow TXV	D Expansion tank
5 Bypass capillary (For sizes 4 and 6 only)	E Pump
6 Filter	F Air vent
7 Liquid receiver	
8 Heat exchanger	

	High pressure switch
	Low pressure switch
	Differential pressure switch
	Tapping point

MQL 4 to 8

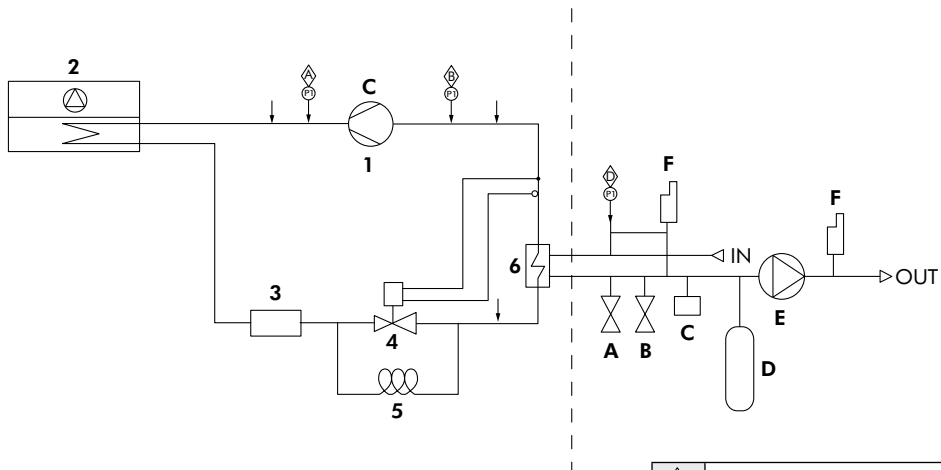

REFRIGERANT CIRCUIT	HYDRAULIC CIRCUIT
1 Compressor	A Drain valve
2 Coil + Fan	B Safety valve
3 Filter	C Water manometer
4 TXV	D Expansion tank
5 Bypass capillary (For sizes 4 and 6 only)	E Pump
6 Heat exchanger	F Air vent

	High pressure switch
	Low pressure switch
	Differential pressure switch
	Tapping point

Refrigerant Flow Diagrams (continued)

MQH 10 to 17

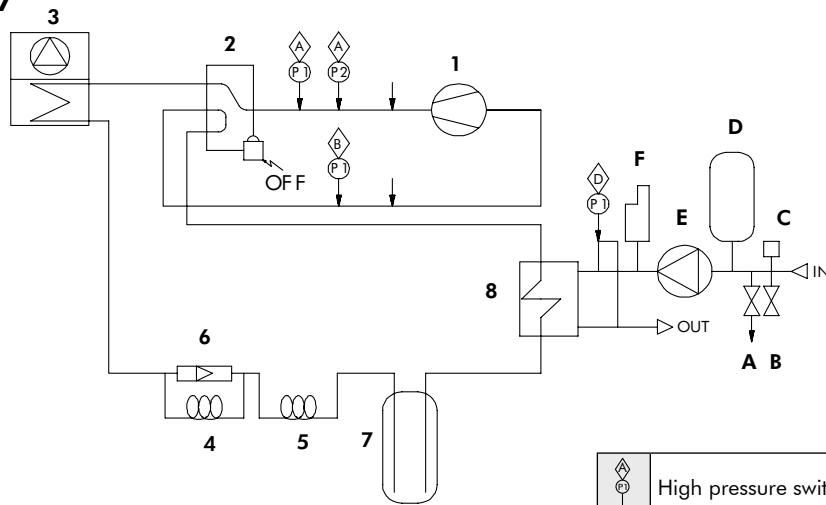

REFRIGERANT CIRCUIT	HYDRAULIC CIRCUIT
1 Compressor	A Drain valve
2 4-way valve	B Safety valve
3 Coil + Fan	C Water manometer
4 Capillary tube	D Expansion tank
5 Capillary tube	E Pump
6 Check valve	F Air vent
7 Liquid receiver	
8 Heat exchanger	

	High pressure switch
	Low pressure switch
	Differential pressure switch
	Tapping point
	Deicing pressure switch

MQL 10 to 17

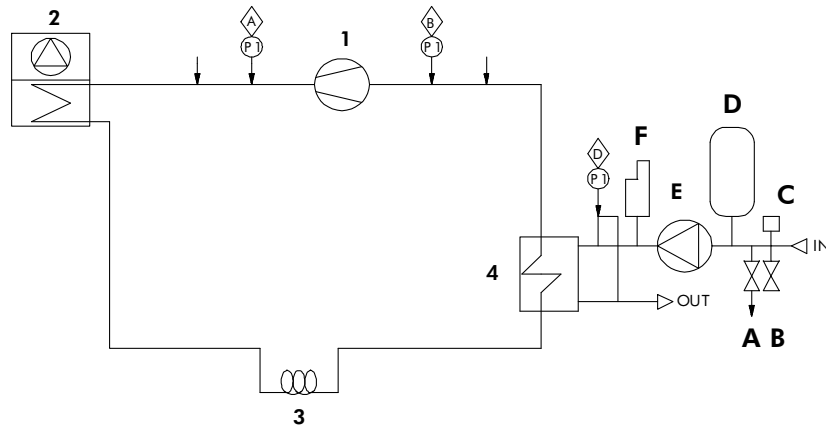

REFRIGERANT CIRCUIT	HYDRAULIC CIRCUIT
1 Compressor	A Drain valve
2 Coil + Fan	B Safety valve
3 Capillary tube	C Water manometer
4 Heat exchanger	D Expansion tank
	E Pump
	F Air vent

	High pressure switch
	Low pressure switch
	Differential pressure switch
	Tapping point

Operating Limits and Correction Factors

Operating limits - MQL/MQH Cooling 4 to 17

Models		4		6		8M		8T		10M		10T		12		15		17	
		Min.	Max.	Min.	Max.	Min.	Max.	Min.	Max.	Min.	Max.	Min.	Max.	Min.	Max.	Min.	Max.	Min.	Max.
Water	Leaving water temperature °C	5	15	5	15	5	15	5	15	5	18	5	18	5	18	5	18	5	18
	Water ΔT °K	4	6	4	6	4	6	4	6	4	6	4	6	4	6	4	6	4	6
	Water flow l/h	644	965	846	1269	1161	1742	1164	1747	1505	2258	1505	2258	1734	2602	2136	3204	2365	3548
	Max. operating pressure barg	28	28	28	28	28	28	28	28	28	28	28	28	28	28	28	28	28	28
Air temperature*		°C		10	46	10	46	10	46	10	46	10	46	10	46	10	46	10	46
Optimal water content		l		16	16	21	21	30	30	30	30	37	37	37	37	42	42	53	60

* Limit with water temperature of 7 °C; minimum air temperature of -10 °C with optional fan speed controller.

Operating limits - MQH 4 to 17

Models		4		6		8M		8T		10M		10T		12		15		17	
		Min.	Max.	Min.	Max.	Min.	Max.	Min.	Max.	Min.	Max.	Min.	Max.	Min.	Max.	Min.	Max.	Min.	Max.
Water	Leaving water temperature °C	30	50	30	50	30	50	30	50	30	50	30	50	30	50	30	50	30	50
	Water ΔT °K	4	6	4	6	4	6	4	6	4	6	4	6	4	6	4	6	4	6
	Water flow l/h	666	999	892	1337	1276	1914	1261	1892	1476	2215	1476	2215	1835	2752	2437	3655	2637	3956
	Max. operating pressure barg	28	28	28	28	28	28	28	28	28	28	28	28	28	28	28	28	28	28
Air temperature*		°C		-5	15	-5	15	-5	15	-5	15	-5	15	-5	15	-5	15	-5	15

* Limit with water temperature of 45 °C.

Evaporator fouling factors

Fouling factors (m ² .°C/kW)	Cooling capacity correction factors	Power consumption correction factors
0.044	1.000	1.000
0.088	0.987	0.995
0.176	0.964	0.985
0.352	0.915	0.962

Condenser fouling factors

Fouling factors (m ² .°C/kW)	Cooling capacity correction factors	Power consumption correction factors
0.044	1.000	1.000
0.088	0.987	1.023
0.176	0.955	1.068
0.352	0.910	1.135

Altitude correction factors

Altitude (m)	Cooling capacity correction factors	Power consumption correction factors
0	1.000	1.000
600	0.987	1.010
1200	0.973	1.020
1800	0.958	1.029
2400	0.943	1.038

Physical Data - MQL 4 to 17

MQL Models		4	6	8M	8T	10M	10T	12	15	17
Cooling Capacity	kW	4.5	5.9	8.1	8.1	10.5	10.5	12.1	14.9	16.5
Input Power (Compressor)	kW	1.5	1.9	3.0	3.0	3.3	3.2	4.0	4.6	5.2
Maximum Input Power (1)	kW	2.2	2.7	4.6	4.6	4.9	4.7	5.6	6.6	7.6
Number of Refrigerant Circuits		1	1	1	1	1	1	1	1	1
Part Load Steps	%	0-100	0-100	0-100	0-100	0-100	0-100	0-100	0-100	0-100
Power Supply (V-Ph-Hz)		230-1-50	230-1-50	230-1-50	400-3+N-50	230-1-50	400-3+N-50	400-3+N-50	400-3+N-50	400-3+N-50
Startup Type		Direct	Direct	Direct	Direct	Direct	Direct	Direct	Direct	Direct
REFRIGERANT										
Type		R407C	R407C	R407C	R407C	R407C	R407C	R407C	R407C	R407C
Charge	kg	1.2	2.1	2	2	2.42	2.42	2.42	3.6	3
COMPRESSOR										
Number		1	1	1	1	1	1	1	1	1
Type		Rotative	Rotative	Scroll	Scroll	Scroll	Scroll	Scroll	Scroll	Scroll
EVAPORATOR										
Number		1	1	1	1	1	1	1	1	1
Type		Plate	Plate	Plate	Plate	Plate	Plate	Plate	Plate	Plate
Antifreeze Heater	W	35	35	35	35	30	30	30	30	30
COIL										
Number		1	1	1	1	1	1	1	1	1
Face Surface Area	l x h	640 x 810	640 x 810	640 x 810	640 x 810	1200 x 890	1200 x 890	1200 x 890	1200 x 890	1200 x 890
Number of Rows		1	2	2	2	2	2	2	3	3
FANS										
Number		1	1	1	1	2	2	2	2	2
Air Flow Rate	m ³ /h	2900	2800	2800	2800	5600	5600	5600	5500	5500
Speed	rpm	800	800	800	800	800	800	800	800	800
Input Power	kW	0.15	0.15	0.15	0.15	0.3	0.3	0.3	0.3	0.3
WATER CONNECTIONS										
Type		Female GAS Threaded								
Inlet Diameter	inch	1"	1"	1"	1"	1"	1"	1"	1"	1"
Outlet Diameter	inch	1"	1"	1"	1"	1"	1"	1"	1"	1"
WEIGHT										
Shipping Weight	kg	97	104	110	110	153	153	158	160	166
DIMENSIONS										
Length	mm	1182	1182	1182	1182	1182	1182	1182	1182	1182
Width	mm	400	400	400	400	400	400	400	400	400
Height	mm	905	905	905	905	1309	1309	1309	1309	1309
SOUND DATA										
Sound Power Level	dB(A)	66	66	67	67	69	69	70	71	71
Sound Pressure Level (2)	dB(A)	40.3	40.3	41.3	41.3	43.3	43.3	44.3	45.3	45.3

(1) Calculated as the maximum power input of compressor plus the maximum input power of fans and pump.

(2) Sound pressure calculated at 5 metres.

Physical Data - MQH 4 to 17

MQH Models		4	6	8M	8T	10M	10T	12	15	17
Cooling Capacity	kW	4.5	5.9	8.1	8.1	10.5	10.5	12.1	14.9	16.5
Input Power (Compressor)	kW	1.5	1.9	3.0	3.0	3.3	3.2	4.0	4.65	5.2
Maximum Input Power (1)	kW	2.2	2.7	4.6	4.6	4.9	4.7	5.6	6.6	7.6
Heating Capacity	kW	4.6	6.2	8.9	8.8	10.3	10.3	12.8	17.0	18.4
Input Power (Compressor)	kW	1.5	1.9	3.2	3.0	3.5	3.4	4.1	4.7	5.3
Number of Refrigerant Circuits		1	1	1	1	1	1	1	1	1
Part Load Steps	%	0-100	0-100	0-100	0-100	0-100	0-100	0-100	0-100	0-100
Power Supply (V-Ph-Hz)		230-1-50	230-1-50	230-1-50	400/3+N/50	230-1-50	400/3+N/50	400/3+N/50	400/3+N/50	400/3+N/50
Startup Type		Direct	Direct	Direct	Direct	Direct	Direct	Direct	Direct	Direct
REFRIGERANT										
Type		R407C	R407C	R407C	R407C	R407C	R407C	R407C	R407C	R407C
Charge	kg	1.2	2.1	2	2	2.66	2.66	2.74	3.8	3.2
COMPRESSOR										
Number		1	1	1	1	1	1	1	1	1
Type		Rotative	Rotative	Scroll	Scroll	Scroll	Scroll	Scroll	Scroll	Scroll
EVAPORATOR										
Number		1	1	1	1	1	1	1	1	1
Type		Plate	Plate	Plate	Plate	Plate	Plate	Plate	Plate	Plate
Antifreeze Heater	W	35	35	35	35	30	30	30	30	30
COIL										
Number		1	1	1	1	1	1	1	1	1
Face Surface Area	l x h	640 x 810	640 x 810	640 x 810	640 x 810	1200 x 890	1200 x 890	1200 x 890	1200 x 890	1200 x 890
Number of Rows		1	2	2	2	2	2	2	3	3
FANS										
Number		1	1	1	1	2	2	2	2	2
Air Flow Rate	m ³ /h	2900	2800	2800	2800	5600	5600	5600	5500	5500
Speed	rpm	800	800	800	800	800	800	800	800	800
Input Power	kW	0.15	0.15	0.15	0.15	0.3	0.3	0.3	0.3	0.3
WATER CONNECTIONS										
Type		Female GAS Threaded								
Inlet Diameter	inch	1"	1"	1"	1"	1"	1"	1"	1"	1"
Outlet Diameter	inch	1"	1"	1"	1"	1"	1"	1"	1"	1"
WEIGHT										
Shipping Weight	kg	97	104	110	110	153	153	158	160	166
DIMENSIONS										
Length	mm	1182	1182	1182	1182	1182	1182	1182	1182	1182
Width	mm	400	400	400	400	400	400	400	400	400
Height	mm	905	905	905	905	1309	1309	1309	1309	1309
SOUND DATA										
Sound Power Level	dB(A)	66	66	67	67	69	69	70	71	71
Sound Pressure Level (2)	dB(A)	40.3	40.3	41.3	41.3	43.3	43.3	44.3	45.3	45.3

(1) Calculated as the maximum power input of compressor plus the maximum input power of fans and pump.

(2) Sound pressure calculated at 5 metres.

Electrical Data

Units - MQL/MQH

MQL/MQH Models		4	6	8M	8T	10M	10T	12	15	17
Basic unit with pump										
Nominal supply voltage	V-Ph-Hz	230-1-50			400-3+N-50	230-1-50	400-3+N-50			
Max. absorbed power	kW	2.2	2.7	4.6	4.6	5.6	5.4	6.3	7.3	8.3
Nominal current	A	8.3	10.1	16.4	7.5	19.7	9.6	11.2	11.7	13.5
Max. current (FLA)	A	9.7	11.7	20.7	8.6	26.4	11.4	13	14.7	16.9
Max. starting current (LRA)	A	38	53	77	37	115	51	67	75	102
Fuses	A	16	16	25	16	-	-	-	-	-
Cable section	mm ²	2.5	2.5	4.0	2.5	-	-	-	-	-

Compressors and pumps

MQL/MQH Models		4	6	8M	8T	10M	10T	12	15	17
Compressors										
Quantity		1	1	1	1	1	1	1	1	1
Max. absorbed power	kW	1.8	2.3	4.2	4.2	4.9	4.7	5.6	6.6	7.6
Nominal current	A	6.6	8.4	14.7	5.8	16.3	6.2	7.8	8.3	10.1
Max. current (FLA)	A	8	10	19	6.9	23	8	9.6	11.3	14
Max. starting current (LRA)	A	37	52	76	36	114	50	66	74	101
Crankcase heater	W	-	-	70	70	70	70	70	70	70
Pump										
Supply voltage	V-Ph-Hz	230-1-50								
Nominal power	kW	0.2	0.2	0.2	0.2	0.4	0.4	0.4	0.4	0.4
Nominal absorbed current	A	1.0	1.0	1.0	1.0	2.0	2.0	2.0	2.0	2.0

Fans

MQL/MQH Models		4	6	8M	8T	10M	10T	12	15	17
Standard fan										
Supply voltage	V-Ph-Hz	230-1-50								
Quantity		1	1	1	1	2	2	2	2	2
Total nominal power	kW	0.15	0.15	0.15	0.15	0.3	0.3	0.3	0.3	0.3
Total absorbed current (FLA)	A	0.7	0.7	0.7	0.7	1.4	1.4	1.4	1.4	1.4

Sound Data - MQL/MQH 4 to 17

Sound Power Level - Lw dB(A)

MQL/MQH Models	Frequency in octave band (Hz)							Global Lw(A)
	125	250	500	1000	2000	4000	8000	
4	70	67	64	61	55	49	43	66
6	70	67	64	61	55	49	43	66
8	71	68	65	62	56	50	44	67
10	60	61	63	64	60	53	41	69
12	60	63	64	64	60	53	42	70
15	60	65	65	66	61	54	42	71
17	60	65	65	66	61	54	42	71

Sound Pressure Level - Lp dB(A)

MQL/MQH Models	Frequency in octave band (Hz)							Global Lp(A)
	125	250	500	1000	2000	4000	8000	
4	44	41	38	35	29	23	17	40
6	44	41	38	35	29	23	17	40
8	45	42	39	36	30	24	18	41
10	34	35	37	38	34	27	15	43
12	34	37	38	38	34	27	16	44
15	34	39	39	40	35	28	16	45
17	34	39	39	40	35	28	16	45

Note : Sound pressure level calculated at a distance of 5 metres. Factor of direction Q=2. Tolerance 2 dB.

Cooling Capacities - MQL 4 to 17

MQL Model	LWT (°C)	Ambient air temperature (°C)													
		25		30		32		35		40		43		46	
		Cool (Kw)	Input (kW)	Cool (Kw)	Input (kW)	Cool (Kw)	Input (kW)	Cool (Kw)	Input (kW)	Cool (Kw)	Input (kW)	Cool (Kw)	Input (kW)	Cool (Kw)	Input (kW)
4	5	4.9	1.2	4.6	1.3	4.4	1.4	4.2	1.5	3.9	1.6	3.6	1.7	3.4	1.8
	6	5.1	1.2	4.7	1.4	4.6	1.4	4.4	1.5	4.0	1.6	3.8	1.7	3.6	1.8
	7	5.2	1.3	4.9	1.4	4.7	1.4	4.5	1.5	4.1	1.6	3.9	1.7	3.7	1.8
	8	5.4	1.3	5.0	1.4	4.9	1.4	4.6	1.5	4.3	1.6	4.0	1.7	3.8	1.8
	10	5.7	1.3	5.3	1.4	5.1	1.5	4.8	1.5	4.5	1.7	4.3	1.8	4.1	1.9
	12	6.1	1.3	5.6	1.4	5.5	1.5	5.2	1.6	4.8	1.7	4.6	1.8	4.4	1.9
	15	6.6	1.4	6.1	1.5	6.0	1.5	5.7	1.6	5.3	1.8	5.1	1.9		
6	5	6.5	1.6	6.0	1.7	5.8	1.8	5.5	1.9	5.1	2.0	4.8	2.1	4.5	2.2
	6	6.7	1.6	6.2	1.7	6.0	1.8	5.7	1.9	5.2	2.0	5.0	2.2	4.7	2.3
	7	6.9	1.6	6.4	1.8	6.2	1.8	5.9	1.9	5.4	2.1	5.1	2.2	4.8	2.3
	8	7.1	1.6	6.6	1.8	6.4	1.8	6.1	1.9	5.6	2.1	5.3	2.2	5.0	2.3
	10	7.5	1.7	7.0	1.8	6.8	1.9	6.3	1.9	6.0	2.1	5.7	2.3	5.4	2.4
	12	8.0	1.7	7.4	1.8	7.2	1.9	6.8	2.0	6.3	2.2	6.1	2.3	5.8	2.4
	15	8.7	1.8	8.1	1.9	7.8	2.0	7.5	2.1	7.0	2.3	6.7	2.4		
8M	5	8.6	2.5	8.1	2.7	7.9	2.8	7.6	2.9	7.2	3.2	6.9	3.4	6.6	3.5
	6	8.8	2.5	8.3	2.7	8.2	2.8	7.9	3.0	7.4	3.2	7.1	3.4		
	7	9.1	2.5	8.6	2.8	8.4	2.9	8.1	3.0	7.6	3.3	7.3	3.4		
	8	9.3	2.5	8.8	2.8	8.6	2.9	8.3	3.0	7.8	3.3	7.6	3.4		
	10	9.8	2.6	9.3	2.8	9.1	2.9	8.6	3.1	8.3	3.3				
	12	10.3	2.6	9.8	2.9	9.6	3.0	9.3	3.1	8.8	3.4				
	15	11.1	2.7	10.5	3.0	10.3	3.1	10.0	3.2						
8T	5	8.6	2.5	8.1	2.7	7.9	2.8	7.7	3.0	7.2	3.2	6.9	3.4	6.7	3.6
	6	8.8	2.5	8.4	2.8	8.2	2.9	7.9	3.0	7.4	3.3	7.1	3.4		
	7	9.1	2.5	8.6	2.8	8.4	2.9	8.1	3.0	7.7	3.3	7.4	3.5		
	8	9.3	2.6	8.8	2.8	8.7	2.9	8.4	3.1	7.9	3.3	7.6	3.5		
	10	9.8	2.6	9.3	2.9	9.1	3.0	8.6	3.1	8.3	3.4				
	12	10.4	2.7	9.8	2.9	9.6	3.0	9.3	3.2	8.8	3.4				
	15	11.1	2.8	10.6	3.0	10.4	3.1	10.0	3.2						
10M	5	10.8	2.7	10.1	3.0	9.7	3.2	9.4	3.4	8.9	3.6	8.5	4.0	8.1	4.6
	6	11.1	2.7	10.4	3.0	10.2	3.2	10.0	3.3	9.2	3.6	8.8	4.0	8.4	4.6
	7	11.5	2.7	10.8	3.0	10.6	3.2	10.5	3.3	9.5	3.6	9.1	4.0	8.7	4.6
	8	11.8	2.7	11.1	3.0	10.8	3.2	10.6	3.3	9.8	3.6	9.4	4.0	9.0	4.6
	10	13.1	2.7	11.8	3.0	11.3	3.2	11.0	3.3	10.4	3.6	9.9	4.0	9.4	4.5
	12	13.1	2.7	12.2	3.0	11.7	3.2	11.4	3.3	10.8	3.6	10.2	4.0	9.7	4.5
	15	13.6	2.7	12.7	3.0	12.1	3.2	11.8	3.3	11.3	3.6	10.5	3.9	10.0	4.5
	18	14.8	2.7	13.7	3.0	13.1	3.2	12.6	3.3	12.2	3.5	11.3	3.9	10.7	4.5
10T	5	10.8	2.7	10.1	2.9	9.7	3.1	9.4	3.3	8.9	3.5	8.5	3.9	8.1	4.4
	6	11.1	2.6	10.4	2.9	10.2	3.1	10.0	3.2	9.2	3.5	8.8	3.9	8.4	4.4
	7	11.5	2.6	10.8	2.9	10.6	3.1	10.5	3.2	9.5	3.5	9.1	3.9	8.7	4.4
	8	11.8	2.6	11.1	2.9	10.8	3.1	10.6	3.2	9.8	3.5	9.4	3.9	9.0	4.4
	10	13.1	2.6	11.8	2.9	11.3	3.1	11.0	3.2	10.4	3.5	9.9	3.9	9.4	4.4
	12	13.1	2.6	12.2	2.9	11.7	3.1	11.4	3.2	10.8	3.5	10.2	3.8	9.7	4.4
	15	13.6	2.6	12.7	2.9	12.1	3.1	11.8	3.2	11.3	3.4	10.5	3.8	10.0	4.4
	18	14.8	2.6	13.7	2.9	13.1	3.1	12.6	3.2	12.2	3.4	11.3	3.8	10.7	4.4
12	5	12.4	3.3	11.7	3.7	11.2	3.9	10.9	4.1	10.2	4.4	9.8	4.8	9.4	5.5
	6	12.8	3.3	12.0	3.7	11.7	3.9	11.5	4.0	10.6	4.4	10.2	4.8	9.7	5.5
	7	13.2	3.3	12.4	3.7	12.2	3.9	12.1	4.0	11.0	4.4	10.5	4.8	10.1	5.5
	8	13.6	3.3	12.8	3.7	12.5	3.9	12.2	4.0	11.3	4.3	10.9	4.8	10.4	5.5
	10	15.0	3.3	13.6	3.6	13.0	3.9	12.7	4.0	12.0	4.3	11.4	4.8	10.9	5.5
	12	15.0	3.3	14.1	3.6	13.5	3.9	13.1	4.0	12.5	4.3	11.7	4.8	11.1	5.5
	15	15.6	3.2	14.6	3.6	14.0	3.8	13.6	4.0	13.0	4.3	12.1	4.8	11.5	5.5
	18	17.0	3.2	15.8	3.6	15.0	3.8	14.5	4.0	14.1	4.3	13.0	4.8	12.3	5.5
15	5	15.3	3.8	14.3	4.2	13.8	4.5	13.4	4.7	12.6	5.0	12.1	5.5	11.6	6.3
	6	15.8	3.8	14.8	4.2	14.4	4.4	14.1	4.6	13.0	5.0	12.5	5.5	12.0	6.3
	7	16.3	3.8	15.3	4.2	15.1	4.4	14.9	4.6	13.5	5.0	12.9	5.5	12.4	6.3
	8	16.8	3.8	15.8	4.2	15.4	4.4	15.1	4.6	13.9	5.0	13.4	5.5	12.8	6.3
	10	18.5	3.7	16.7	4.2	16.1	4.4	15.6	4.6	14.8	5.0	14.1	5.5	13.4	6.3
	12	18.5	3.7	17.4	4.1	16.6	4.4	16.1	4.6	15.3	4.9	14.5	5.5	13.7	6.3
	15	19.3	3.7	18.0	4.1	17.2	4.4	16.7	4.6	16.0	4.9	14.9	5.5	14.2	6.3
	18	21.0	3.7	19.5	4.1	18.5	4.4	17.9	4.6	17.3	4.9	16.0	5.4	15.2	6.3
17	5	17.0	4.3	15.9	4.8	15.2	5.1	14.8	5.3	13.9	5.7	13.4	6.3	12.8	7.2
	6	17.5	4.3	16.4	4.8	16.0	5.1	15.7	5.3	14.4	5.7	13.8	6.3	13.3	7.2
	7	18.1	4.3	16.9	4.8	16.7	5.0	16.5	5.2	14.9	5.7	14.3	6.3	13.7	7.2
	8	18.6	4.3	17.5	4.8	17.0	5.0	16.7	5.2	15.4	5.7	14.8	6.3	14.2	7.2
	10	20.5	4.3	18.5	4.7	17.8	5.0	17.3	5.3	16.3	5.6	15.6	6.3	14.8	7.2
	12	20.5	4.2	19.2	4.7	18.4	5.0	17.9	5.2	17.0	5.6	16.0	6.2	15.2	7.2
	15	21.3	4.2	20.0	4.7	19.1	5.0	18.5	5.2	17.7	5.6	16.5	6.2	15.7	7.1
	18	23.2	4.2	21.6	4.6	20.5	5.0	19.8	5.2	19.2	5.6	17.8	6.2	16.8	7.1

LWT : Leaving water temperature.

Cooling Capacities - MQH 4 to 17

MQH Model	LWT (°C)	Ambient air temperature (°C)													
		25		30		32		35		40		43		46	
		Cool (Kw)	Input (kW)	Cool (Kw)	Input (kW)	Cool (Kw)	Input (kW)	Cool (Kw)	Input (kW)	Cool (Kw)	Input (kW)	Cool (Kw)	Input (kW)	Cool (Kw)	Input (kW)
4	5	4.9	1.2	4.6	1.3	4.4	1.4	4.2	1.5	3.9	1.6	3.6	1.7	3.4	1.8
	6	5.1	1.2	4.7	1.4	4.6	1.4	4.4	1.5	4.0	1.6	3.8	1.7	3.6	1.8
	7	5.2	1.3	4.9	1.4	4.7	1.4	4.5	1.5	4.1	1.6	3.9	1.7	3.7	1.8
	8	5.4	1.3	5.0	1.4	4.9	1.4	4.6	1.5	4.3	1.6	4.0	1.7	3.8	1.8
	10	5.7	1.3	5.3	1.4	5.1	1.5	4.8	1.5	4.5	1.7	4.3	1.8	4.1	1.9
	12	6.1	1.3	5.6	1.4	5.5	1.5	5.2	1.6	4.8	1.7	4.6	1.8	4.4	1.9
6	5	6.5	1.6	6.0	1.7	5.8	1.8	5.5	1.9	5.1	2.0	4.8	2.1	4.5	2.2
	6	6.7	1.6	6.2	1.7	6.0	1.8	5.7	1.9	5.2	2.0	5.0	2.2	4.7	2.3
	7	6.9	1.6	6.4	1.8	6.2	1.8	5.9	1.9	5.4	2.1	5.1	2.2	4.8	2.3
	8	7.1	1.6	6.6	1.8	6.4	1.8	6.1	1.9	5.6	2.1	5.3	2.2	5.0	2.3
	10	7.5	1.7	7.0	1.8	6.8	1.9	6.3	1.9	6.0	2.1	5.7	2.3	5.4	2.4
	12	8.0	1.7	7.4	1.8	7.2	1.9	6.8	2.0	6.3	2.2	6.1	2.3	5.8	2.4
8M	5	8.6	2.5	8.1	2.7	7.9	2.8	7.6	2.9	7.2	3.2	6.9	3.4	6.6	3.5
	6	8.8	2.5	8.3	2.7	8.2	2.8	7.9	3.0	7.4	3.2	7.1	3.4		
	7	9.1	2.5	8.6	2.8	8.4	2.9	8.1	3.0	7.6	3.3	7.3	3.4		
	8	9.3	2.5	8.8	2.8	8.6	2.9	8.3	3.0	7.8	3.3	7.6	3.4		
	10	9.8	2.6	9.3	2.8	9.1	2.9	8.6	3.1	8.3	3.3				
	12	10.3	2.6	9.8	2.9	9.6	3.0	9.3	3.1	8.8	3.4				
8T	5	8.6	2.5	8.1	2.7	7.9	2.8	7.7	3.0	7.2	3.2	6.9	3.4	6.7	3.6
	6	8.8	2.5	8.4	2.8	8.2	2.9	7.9	3.0	7.4	3.3	7.1	3.4		
	7	9.1	2.5	8.6	2.8	8.4	2.9	8.1	3.0	7.7	3.3	7.4	3.5		
	8	9.3	2.6	8.8	2.8	8.7	2.9	8.4	3.1	7.9	3.3	7.6	3.5		
	10	9.8	2.6	9.3	2.9	9.1	3.0	8.6	3.1	8.3	3.4				
	12	10.4	2.7	9.8	2.9	9.6	3.0	9.3	3.2	8.8	3.4				
10M	5	10.8	2.7	10.1	3.0	9.7	3.2	9.4	3.4	8.9	3.6	8.5	4.0	8.1	4.6
	6	11.1	2.7	10.4	3.0	10.2	3.2	10.0	3.3	9.2	3.6	8.8	4.0	8.4	4.6
	7	11.5	2.7	10.8	3.0	10.6	3.2	10.5	3.3	9.5	3.6	9.1	4.0	8.7	4.6
	8	11.8	2.7	11.1	3.0	10.8	3.2	10.6	3.3	9.8	3.6	9.4	4.0	9.0	4.6
	10	13.1	2.7	11.8	3.0	11.3	3.2	11.0	3.3	10.4	3.6	9.9	4.0	9.4	4.5
	12	13.1	2.7	12.2	3.0	11.7	3.2	11.4	3.3	10.8	3.6	10.2	4.0	9.7	4.5
10T	5	10.8	2.7	10.1	2.9	9.7	3.1	9.4	3.3	8.9	3.5	8.5	3.9	8.1	4.4
	6	11.1	2.6	10.4	2.9	10.2	3.1	10.0	3.2	9.2	3.5	8.8	3.9	8.4	4.4
	7	11.5	2.6	10.8	2.9	10.6	3.1	10.5	3.2	9.5	3.5	9.1	3.9	8.7	4.4
	8	11.8	2.6	11.1	2.9	10.8	3.1	10.6	3.2	9.8	3.5	9.4	3.9	9.0	4.4
	10	13.1	2.6	11.8	2.9	11.3	3.1	11.0	3.2	10.4	3.5	9.9	3.9	9.4	4.4
	12	13.1	2.6	12.2	2.9	11.7	3.1	11.4	3.2	10.8	3.5	10.2	3.8	9.7	4.4
12	5	12.4	3.3	11.7	3.7	11.2	3.9	10.9	4.1	10.2	4.4	9.8	4.8	9.4	5.5
	6	12.8	3.3	12.0	3.7	11.7	3.9	11.5	4.0	10.6	4.4	10.2	4.8	9.7	5.5
	7	13.2	3.3	12.4	3.7	12.2	3.9	12.1	4.0	11.0	4.4	10.5	4.8	10.1	5.5
	8	13.6	3.3	12.8	3.7	12.5	3.9	12.2	4.0	11.3	4.3	10.9	4.8	10.4	5.5
	10	15.0	3.3	13.6	3.6	13.0	3.9	12.7	4.0	12.0	4.3	11.4	4.8	10.9	5.5
	12	15.0	3.3	14.1	3.6	13.5	3.9	13.1	4.0	12.5	4.3	11.7	4.8	11.1	5.5
15	5	15.3	3.8	14.3	4.2	13.8	4.5	13.4	4.7	12.6	5.0	12.1	5.5	11.6	6.3
	6	15.8	3.8	14.8	4.2	14.4	4.4	14.1	4.6	13.0	5.0	12.5	5.5	12.0	6.3
	7	16.3	3.8	15.3	4.2	15.1	4.4	14.9	4.6	13.5	5.0	12.9	5.5	12.4	6.3
	8	16.8	3.8	15.8	4.2	15.4	4.4	15.1	4.6	13.9	5.0	13.4	5.5	12.8	6.3
	10	18.5	3.7	16.7	4.2	16.1	4.4	15.6	4.6	14.8	5.0	14.1	5.5	13.4	6.3
	12	18.5	3.7	17.4	4.1	16.6	4.4	16.1	4.6	15.3	4.9	14.5	5.5	13.7	6.3
17	5	17.0	4.3	15.9	4.8	15.2	5.1	14.8	5.3	13.9	5.7	13.4	6.3	12.8	7.2
	6	17.5	4.3	16.4	4.8	16.0	5.1	15.7	5.3	14.4	5.7	13.8	6.3	13.3	7.2
	7	18.1	4.3	16.9	4.8	16.7	5.0	16.5	5.2	14.9	5.7	14.3	6.3	13.7	7.2
	8	18.6	4.3	17.5	4.8	17.0	5.0	16.7	5.2	15.4	5.7	14.8	6.3	14.2	7.2
	10	20.5	4.3	18.5	4.7	17.8	5.0	17.3	5.3	16.3	5.6	15.6	6.3	14.8	7.2
	12	20.5	4.2	19.2	4.7	18.4	5.0	17.9	5.2	17.0	5.6	16.0	6.2	15.2	7.2
17	15	21.3	4.2	20.0	4.7	19.1	5.0	18.5	5.2	17.7	5.6	16.5	6.2	15.7	7.1
	18	23.2	4.2	21.6	4.6	20.5	5.0	19.8	5.2	19.2	5.6	17.8	6.2	16.8	7.1

LWT : Leaving water temperature.

Heating Capacities - MQH 4 to 17

MQH Model	LWT (°C)	Ambient air temperature (°C)													
		-5		-3		0		5		7		10		15	
		Heat (Kw)	Input (kW)	Heat (Kw)	Input (kW)	Heat (Kw)	Input (kW)	Heat (Kw)	Input (kW)	Heat (Kw)	Input (kW)	Heat (Kw)	Input (kW)	Heat (Kw)	Input (kW)
4	30	3.7	1.1	3.9	1.1	4.2	1.1	4.9	1.1	5.2	1.1	5.7	1.1	6.7	1.1
	35	3.6	1.2	3.8	1.2	4.1	1.2	4.7	1.2	5.0	1.2	5.5	1.2	6.4	1.3
	40	3.5	1.3	3.7	1.3	4.0	1.3	4.6	1.3	4.8	1.2	5.3	1.3	6.1	1.4
	45	3.5	1.4	3.6	1.4	3.9	1.4	4.4	1.5	4.6	1.5	5.1	1.5	5.9	1.5
	50	3.5	1.5	3.6	1.5	3.9	1.5	4.3	1.5	4.6	1.5	5.0	1.5	5.8	1.6
6	30	4.9	1.4	5.2	1.4	5.7	1.4	6.6	1.4	7.0	1.4	7.7	1.4	9.0	1.5
	35	4.8	1.5	5.1	1.5	5.5	1.5	6.3	1.5	6.7	1.6	7.4	1.6	8.6	1.6
	40	4.7	1.6	5.0	1.7	5.3	1.7	6.1	1.7	6.5	1.6	7.1	1.7	8.2	1.8
	45	4.7	1.8	4.9	1.8	5.2	1.9	5.9	1.9	6.2	1.9	6.8	1.9	7.9	2.0
	50	4.7	1.9	4.8	1.9	5.2	1.9	5.8	2.0	6.1	2.0	6.7	2.0	7.8	2.0
8M	30	6.5	2.3	6.9	2.3	7.6	2.3	8.8	2.4	9.3	2.4	10.1	2.4	11.6	2.5
	35	6.4	2.5	6.8	2.5	7.5	2.6	8.6	2.6	9.1	2.6	9.9	2.7	11.3	2.7
	40	6.4	2.8	6.8	2.8	7.4	2.8	8.5	2.9	9.0	2.6	9.8	2.9	11.1	3.0
	45	6.4	3.1	6.8	3.1	7.4	3.1	8.4	3.2	8.9	3.2	9.6	3.3	10.9	3.3
	50			6.8	3.2	7.4	3.2	8.4	3.3	8.9	3.3	9.6	3.4	10.9	3.5
8T	30	6.4	2.2	6.8	2.2	7.5	2.2	8.7	2.2	9.2	2.3	10.0	2.3	11.4	2.3
	35	6.3	2.4	6.8	2.4	7.4	2.4	8.5	2.5	9.0	2.5	9.8	2.5	11.2	2.6
	40	6.3	2.6	6.7	2.7	7.3	2.7	8.4	2.7	8.9	2.5	9.7	2.8	11.0	2.8
	45	6.3	2.9	6.7	2.9	7.3	3.0	8.3	3.0	8.8	3.0	9.5	3.1	10.8	3.1
	50			6.7	3.0	7.3	3.1	8.3	3.1	8.8	3.1	9.5	3.2	10.7	3.3
10M	30	7.6	2.4	8.1	2.4	8.9	2.5	10.2	2.5	10.7	2.5	11.4	2.5	11.9	2.5
	35	7.4	2.8	7.9	2.8	8.7	2.8	10.0	2.8	10.5	2.8	11.3	2.8	11.8	2.8
	40	7.2	3.1	7.7	3.1	8.5	3.1	9.9	3.1	10.4	3.2	11.2	3.2	11.7	3.2
	45	7.0	3.4	7.6	3.4	8.4	3.4	9.7	3.5	10.3	3.5	11.1	3.5	11.6	3.5
	50	6.8	3.4	7.3	3.4	8.2	3.5	9.5	3.5	10.1	3.5	10.9	3.6	11.5	3.6
10T	30	7.6	2.4	8.1	2.4	8.9	2.4	10.2	2.4	10.7	2.4	11.4	2.4	11.9	2.4
	35	7.4	2.7	7.9	2.7	8.7	2.7	10.0	2.7	10.5	2.7	11.3	2.8	11.8	2.8
	40	7.2	3.0	7.7	3.0	8.5	3.0	9.9	3.1	10.4	3.1	11.2	3.1	11.7	3.1
	45	7.0	3.3	7.6	3.3	8.4	3.3	9.7	3.4	10.3	3.4	11.1	3.4	11.6	3.4
	50	6.8	3.3	7.3	3.3	8.2	3.4	9.5	3.4	10.1	3.4	10.9	3.5	11.5	3.5
12	30	9.5	2.9	10.1	2.9	11.1	2.9	12.6	2.9	13.3	2.9	14.2	2.9	14.8	2.9
	35	9.2	3.2	9.9	3.2	10.8	3.3	12.4	3.3	13.1	3.3	14.1	3.3	14.7	3.3
	40	9.0	3.6	9.6	3.6	10.6	3.6	12.3	3.7	12.9	3.7	13.9	3.7	14.6	3.8
	45	8.7	4.0	9.4	4.0	10.4	4.0	12.1	4.1	12.8	4.1	13.8	4.1	14.5	4.2
	50	8.5	4.0	9.1	4.0	10.2	4.0	11.9	4.1	12.5	4.1	13.5	4.2	14.2	4.2
15	30	12.6	3.3	13.4	3.3	14.7	3.3	16.8	3.3	17.6	3.3	18.9	3.3	19.7	3.3
	35	12.2	3.7	13.1	3.7	14.4	3.7	16.5	3.8	17.4	3.8	18.7	3.8	19.5	3.8
	40	11.9	4.1	12.8	4.1	14.1	4.2	16.3	4.2	17.2	4.3	18.5	4.3	19.4	4.3
	45	11.6	4.5	12.5	4.6	13.8	4.6	16.1	4.7	17.0	4.7	18.3	4.7	19.2	4.8
	50	11.2	4.6	12.1	4.6	13.5	4.6	15.7	4.7	16.6	4.7	18.0	4.8	18.9	4.8
17	30	13.6	3.7	14.5	3.7	15.9	3.7	18.2	3.7	19.1	3.7	20.4	3.8	21.3	3.8
	35	13.2	4.2	14.2	4.2	15.6	4.2	17.9	4.2	18.8	4.3	20.2	4.3	21.1	4.3
	40	12.9	4.6	13.8	4.7	15.3	4.7	17.6	4.8	18.6	4.8	20.0	4.8	20.9	4.9
	45	12.5	5.1	13.5	5.1	15.0	5.2	17.4	5.3	18.4	5.3	19.8	5.3	20.8	5.4
	50	12.2	5.1	13.1	5.2	14.6	5.2	17.0	5.3	18.0	5.4	19.5	5.4	20.5	5.4

LWT : Leaving water temperature.

Water Pressure Drop Curves

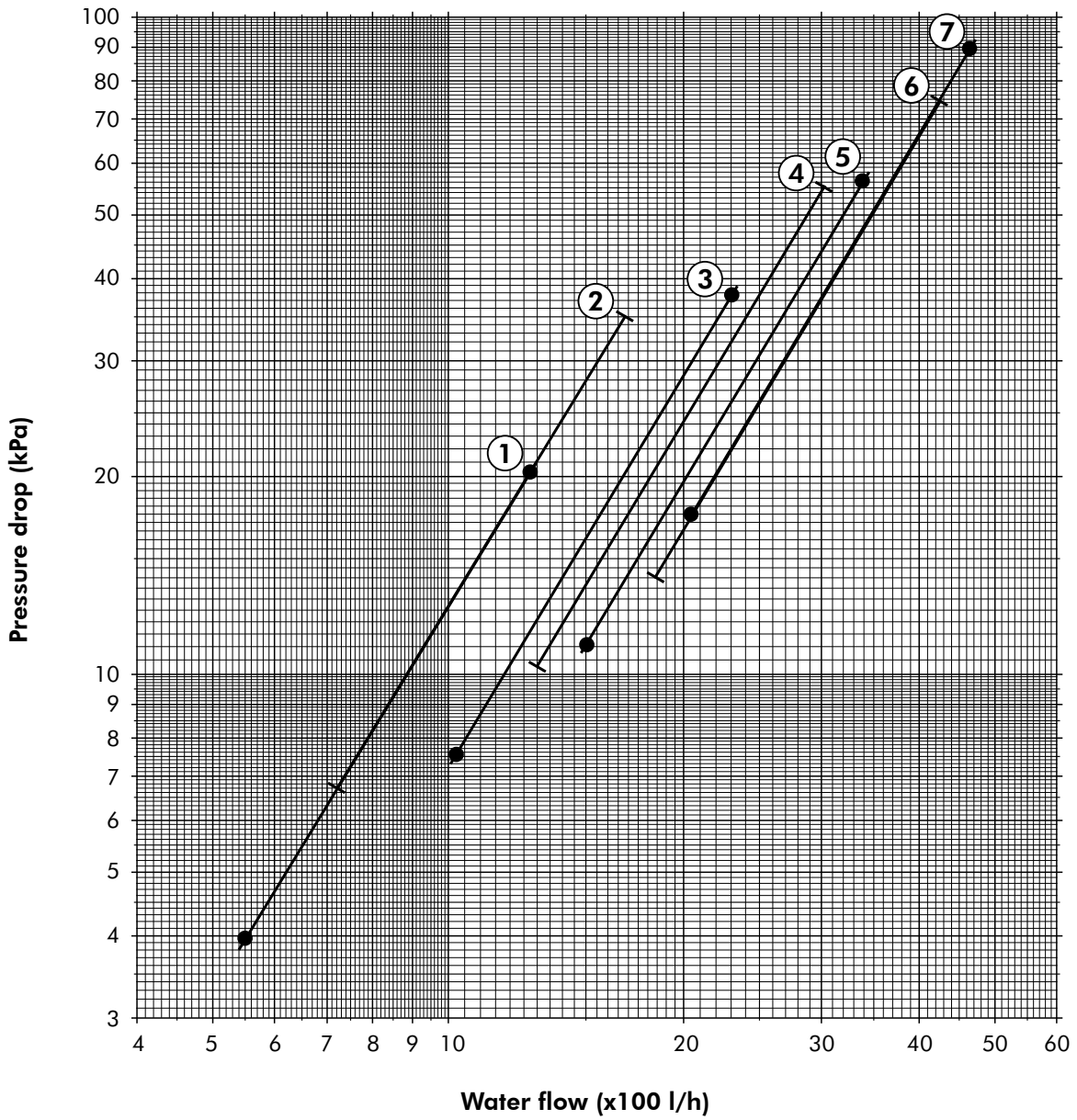

- ① MQL/MQH 4
- ② MQL/MQH 6
- ③ MQL/MQH 8
- ④ MQL/MQH 10
- ⑤ MQL/MQH 12
- ⑥ MQL/MQH 15
- ⑦ MQL/MQH 17

Water Pump Curves

Available Static Pressure - MQL/MQH 4 to 8 (High speed)

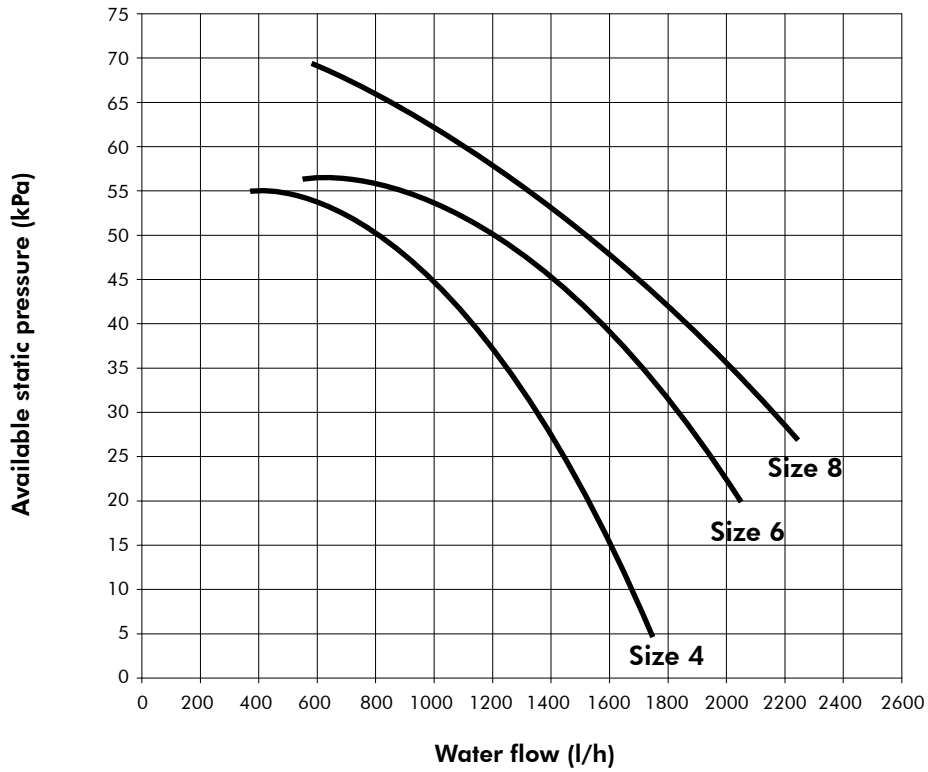

Available Static Pressure - MQL/MQH 10 to 17 (High speed)

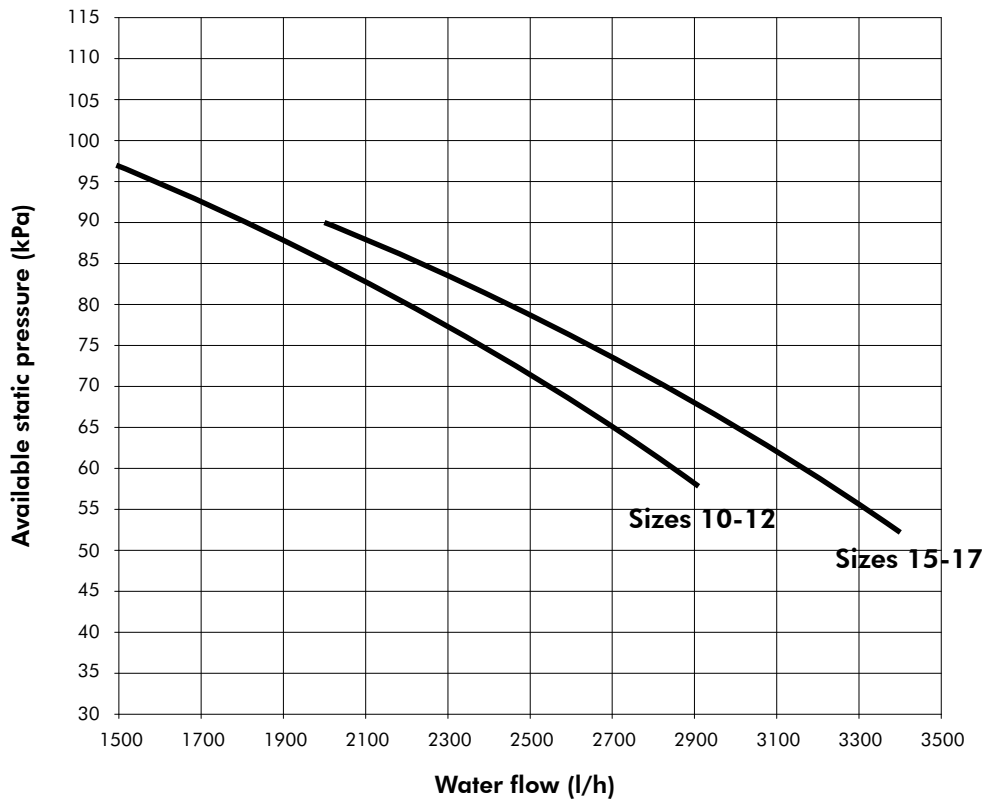

Water Pump Curves (continued)

Available Static Pressure - MQL/MQH 4 to 8 (Medium speed)

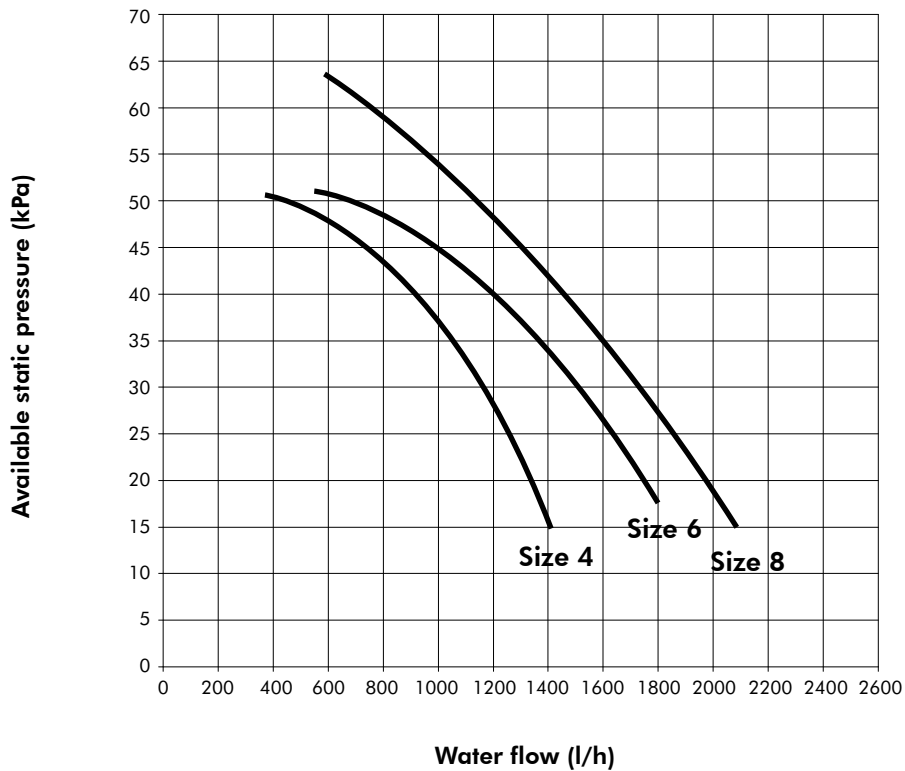

Available Static Pressure - MQL/MQH 10 to 17 (Medium speed)

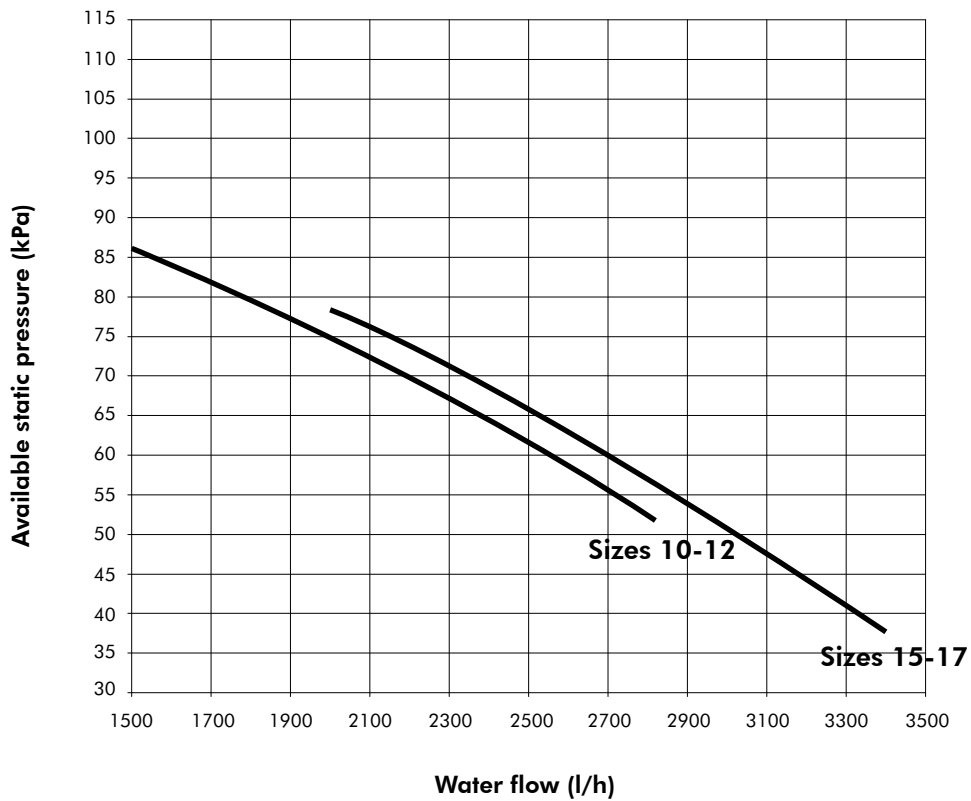

Water Pump Curves (continued)

Available Static Pressure - MQL/MQH 4 to 8 (Low speed)

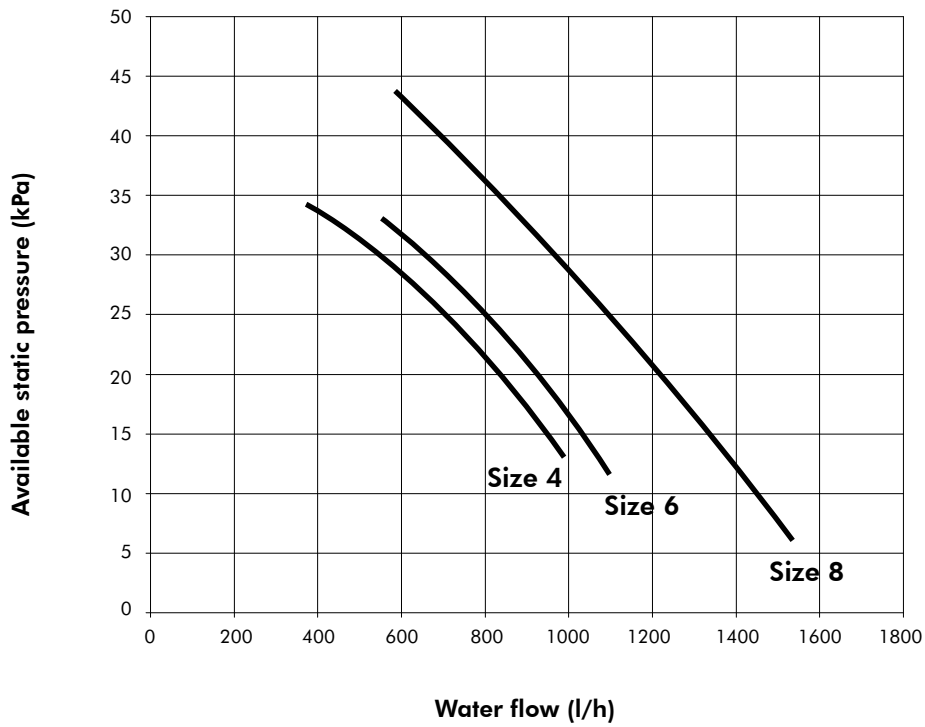

Available Static Pressure - MQL/MQH 10 & 12 (Low speed)

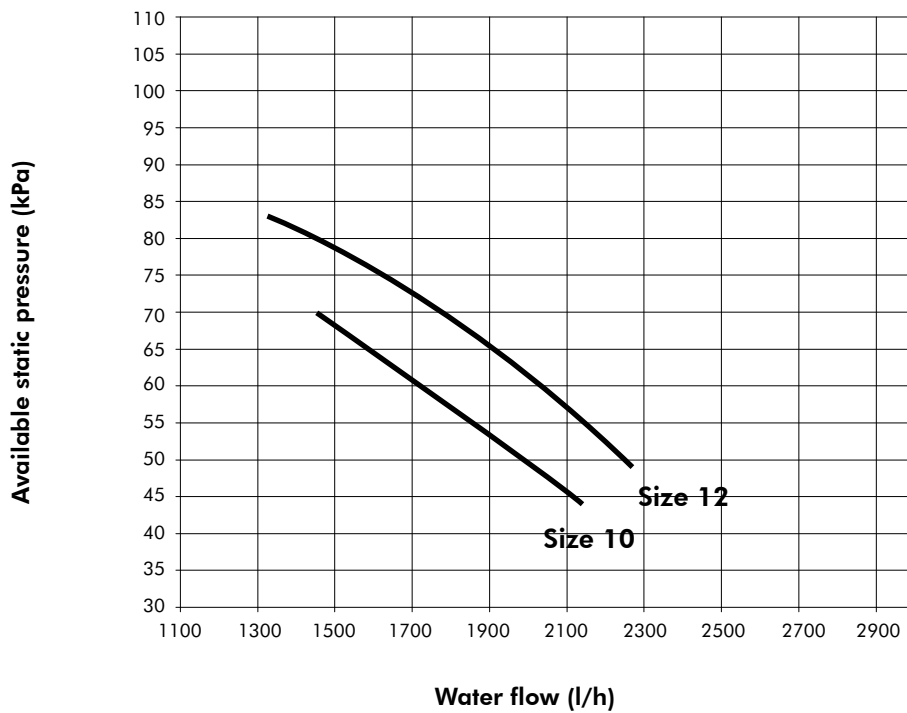

Dimensions (mm) - MQL/MQH 4 to 8

FRONT VIEW

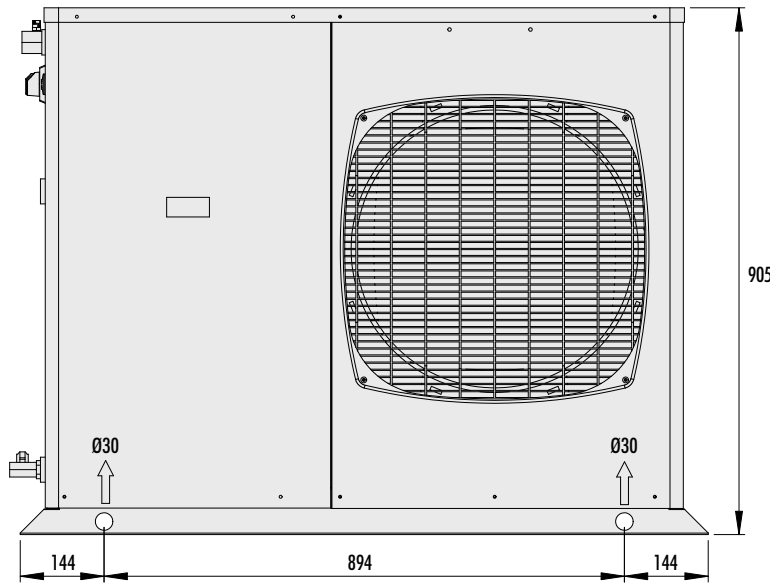

SIDE VIEW

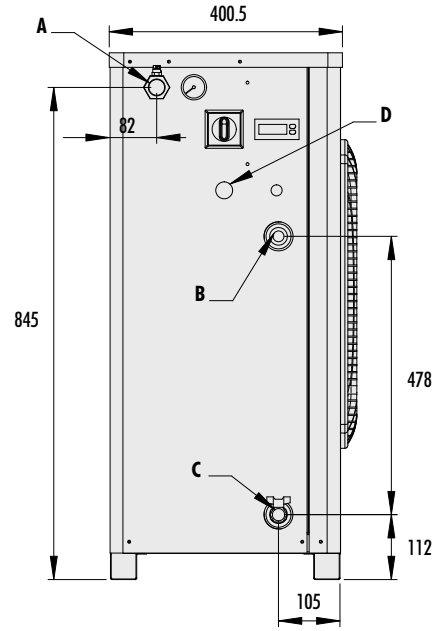

TOP VIEW

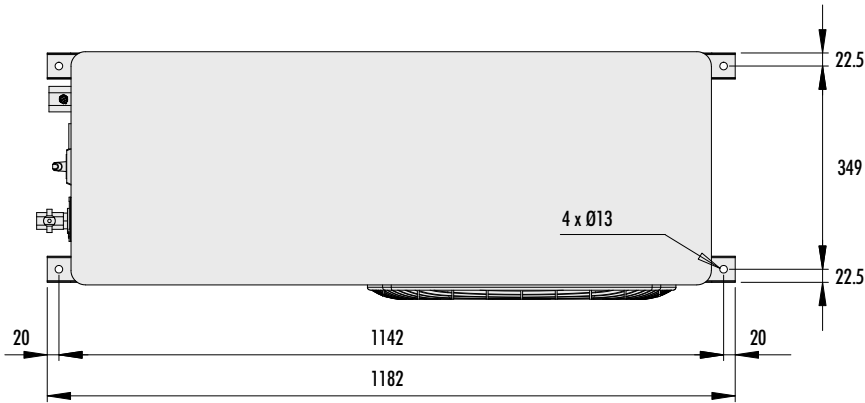

NOTES	
A	Water outlet Ø1" gas female
B	Water inlet Ø1" gas female
C	Water drain Ø1/2" gas female
D	Electrical power supply

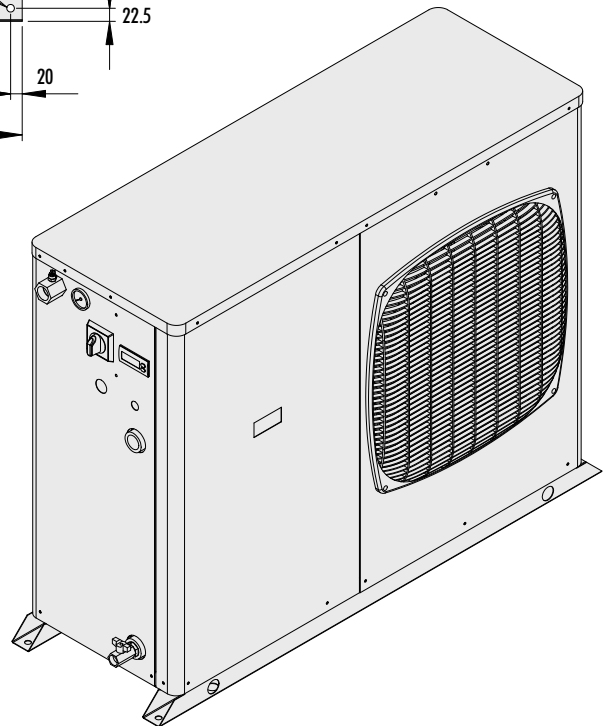

Dimensions (mm) - MQL/MQH 10 to 17

FRONT VIEW

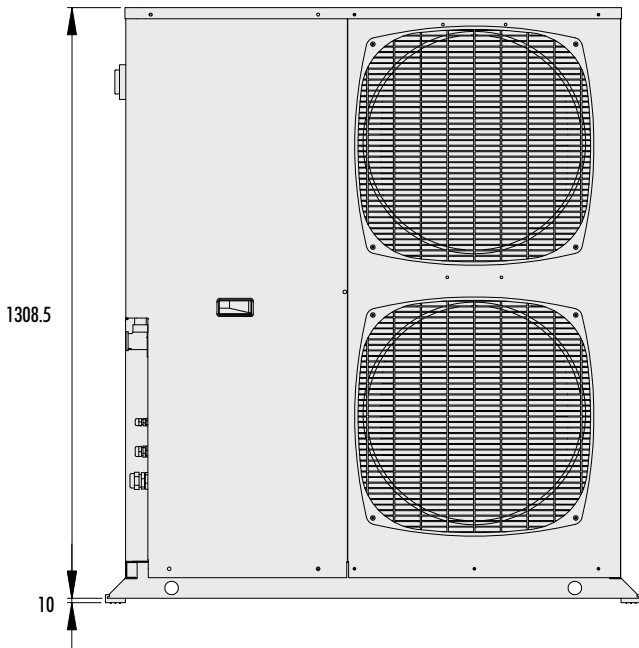

SIDE VIEW

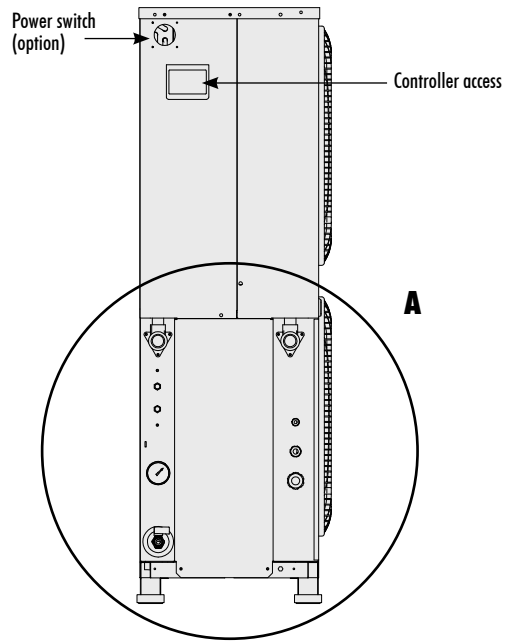

TOP VIEW

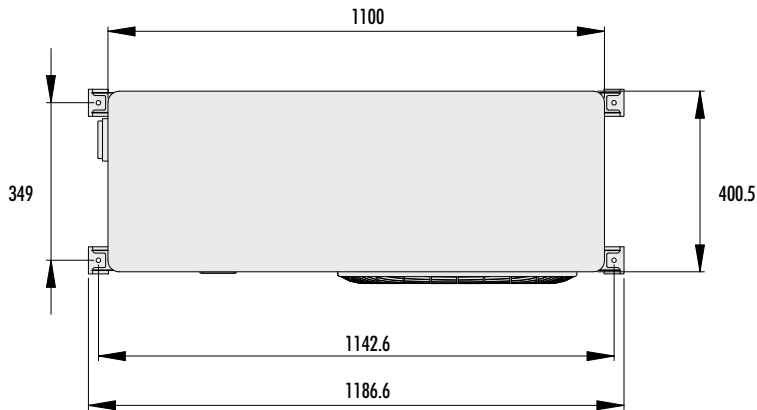

DETAIL A

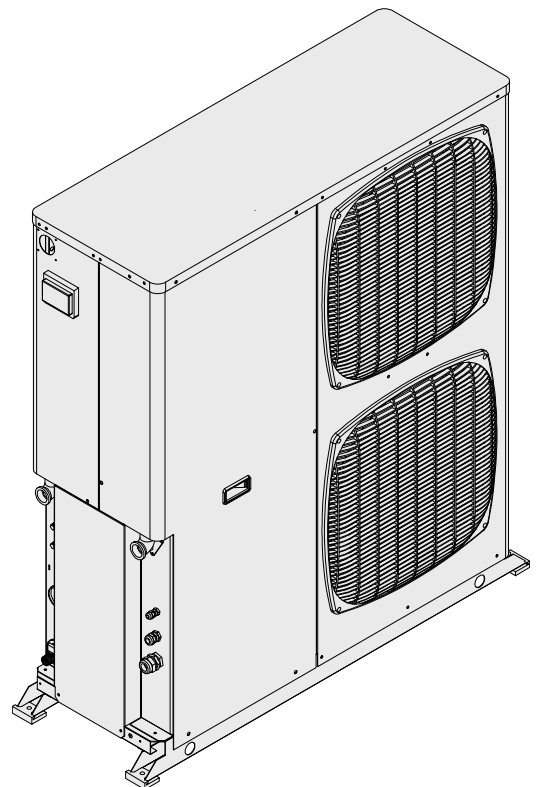
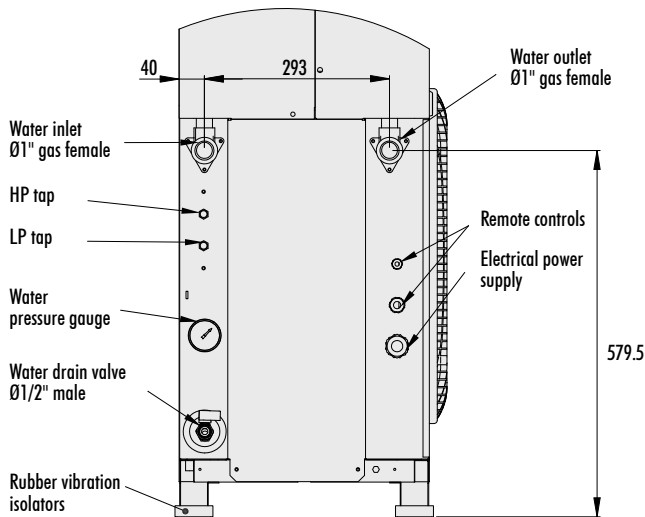

Space Requirements

MQL/MQH 4 to 8

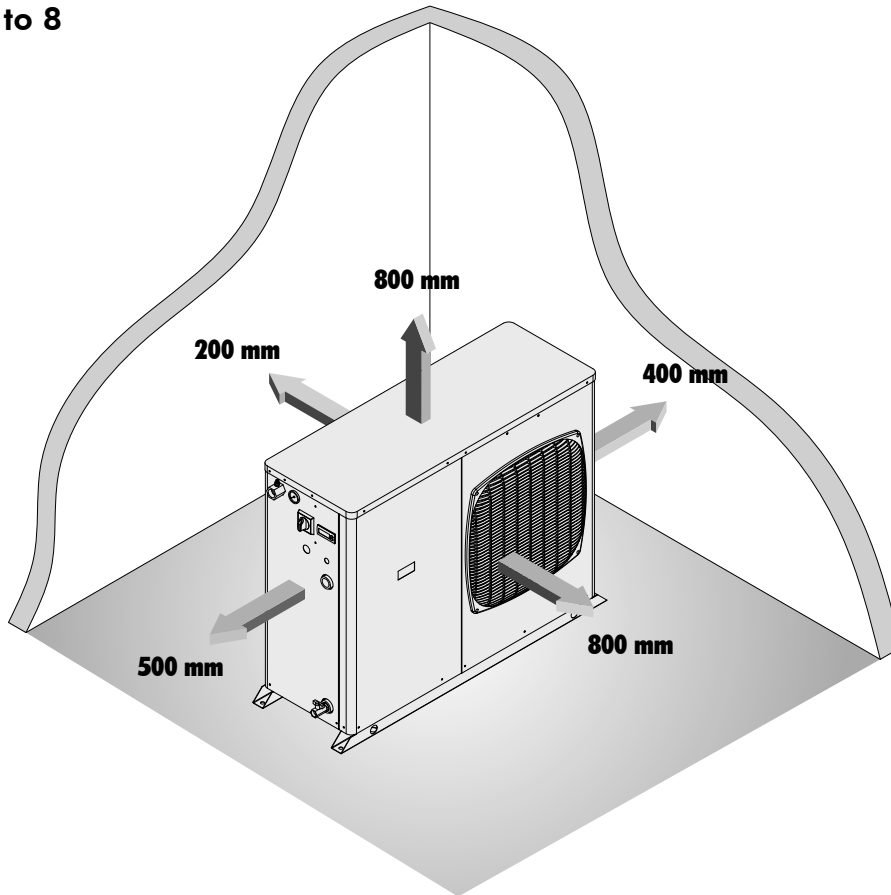

MQL/MQH 10 to 17

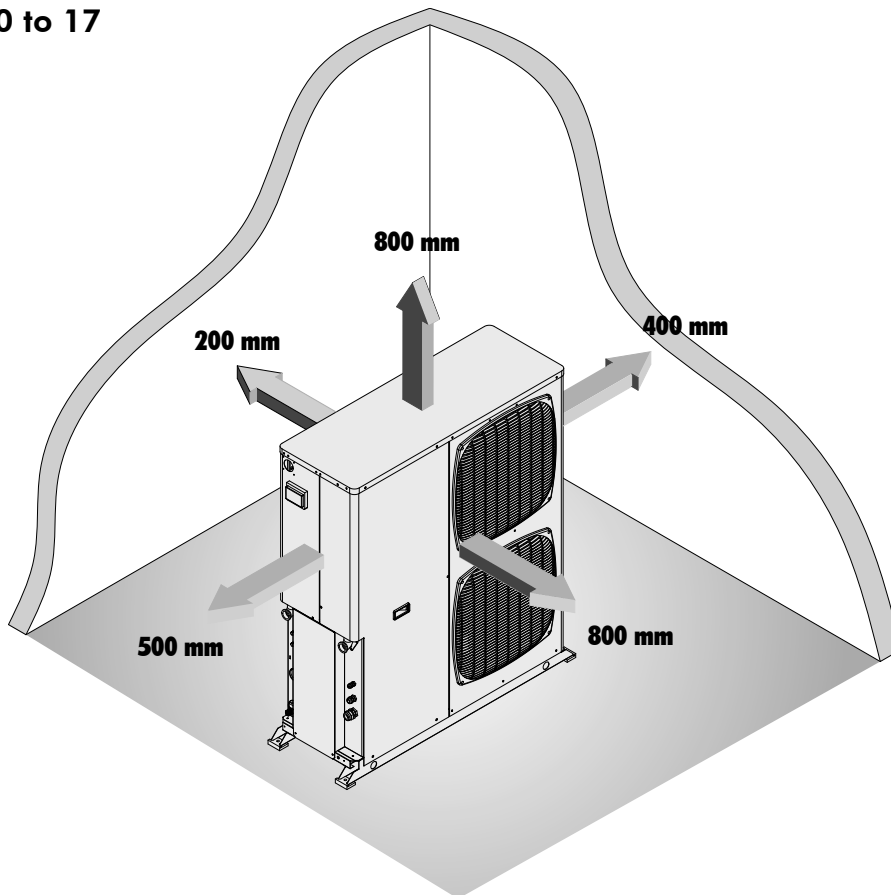

No Pump Kit (optional) - MQL/MQH 4 to 8

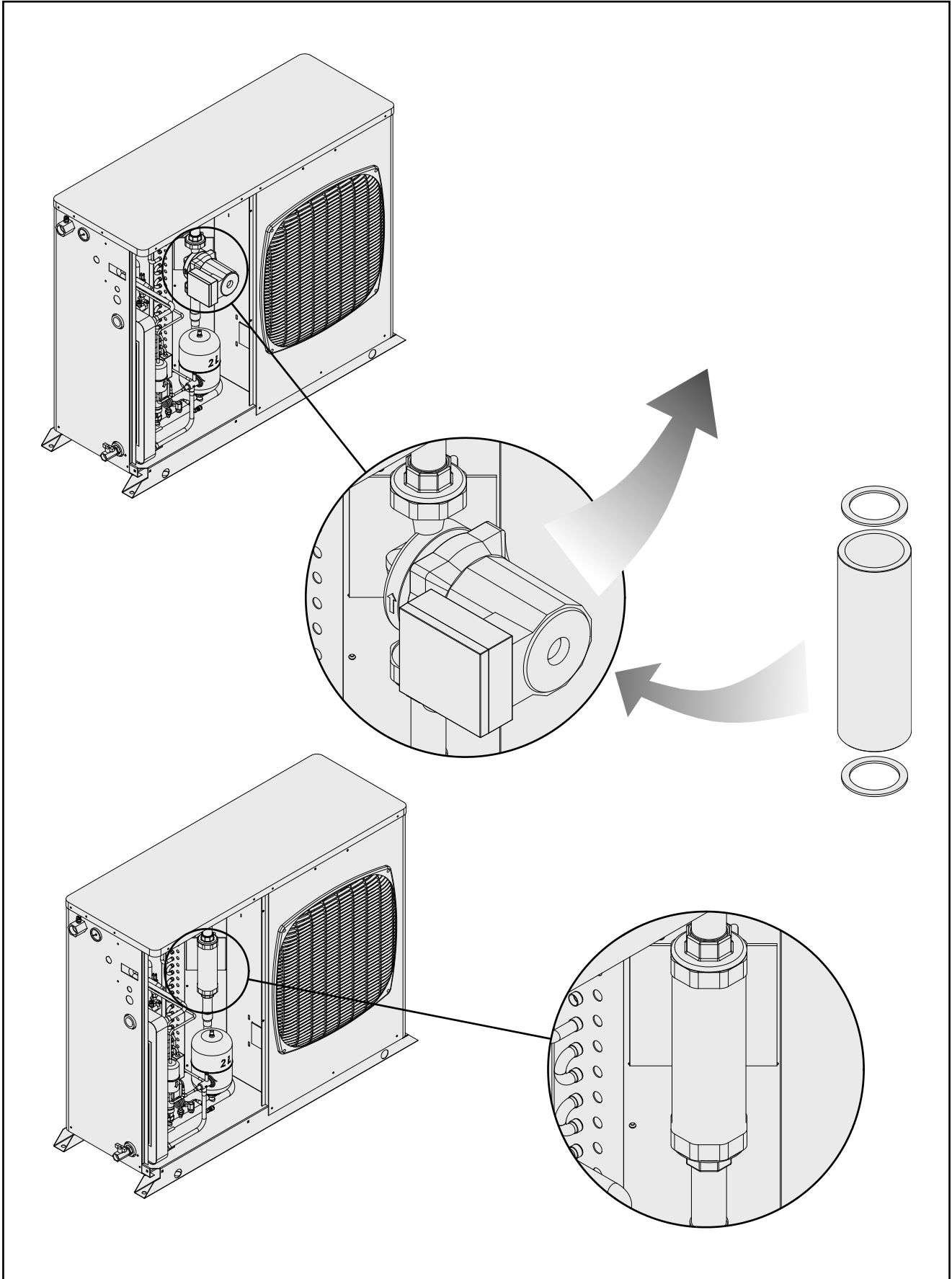

External Water Tank (optional) - MQL/MQH 4 to 8

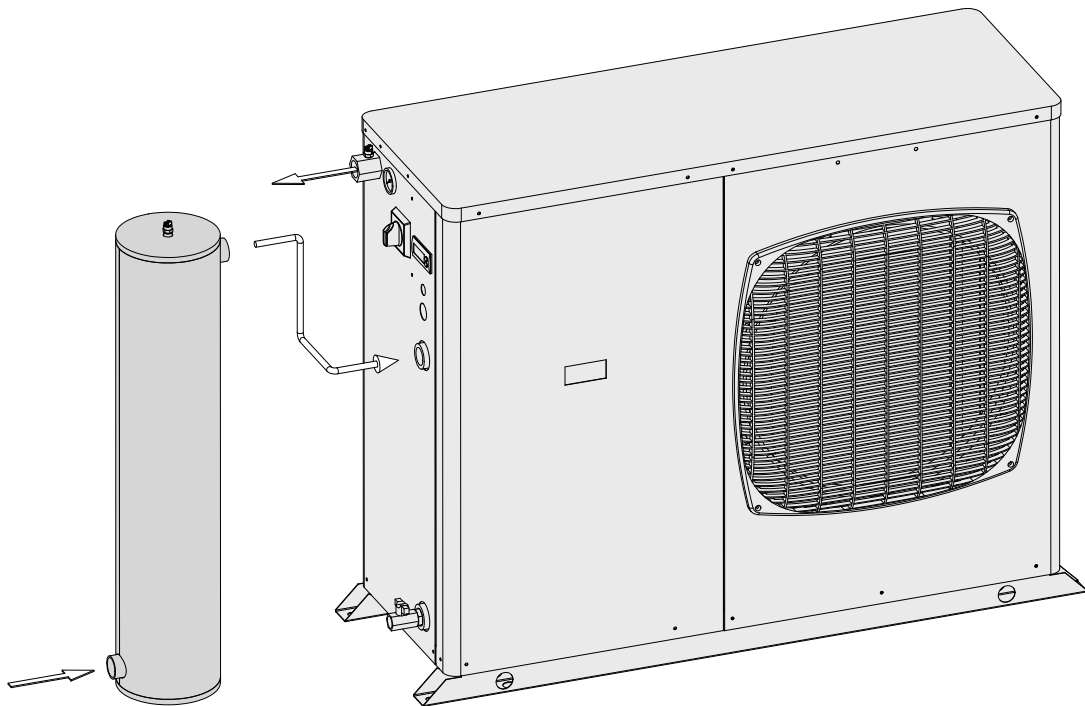

External Water Tank Dimensions		
Volume	l	15
Diameter	mm	170
Height	mm	820
Input/output connection	1" female gas threaded	
Operating weight	kg	25

Notes

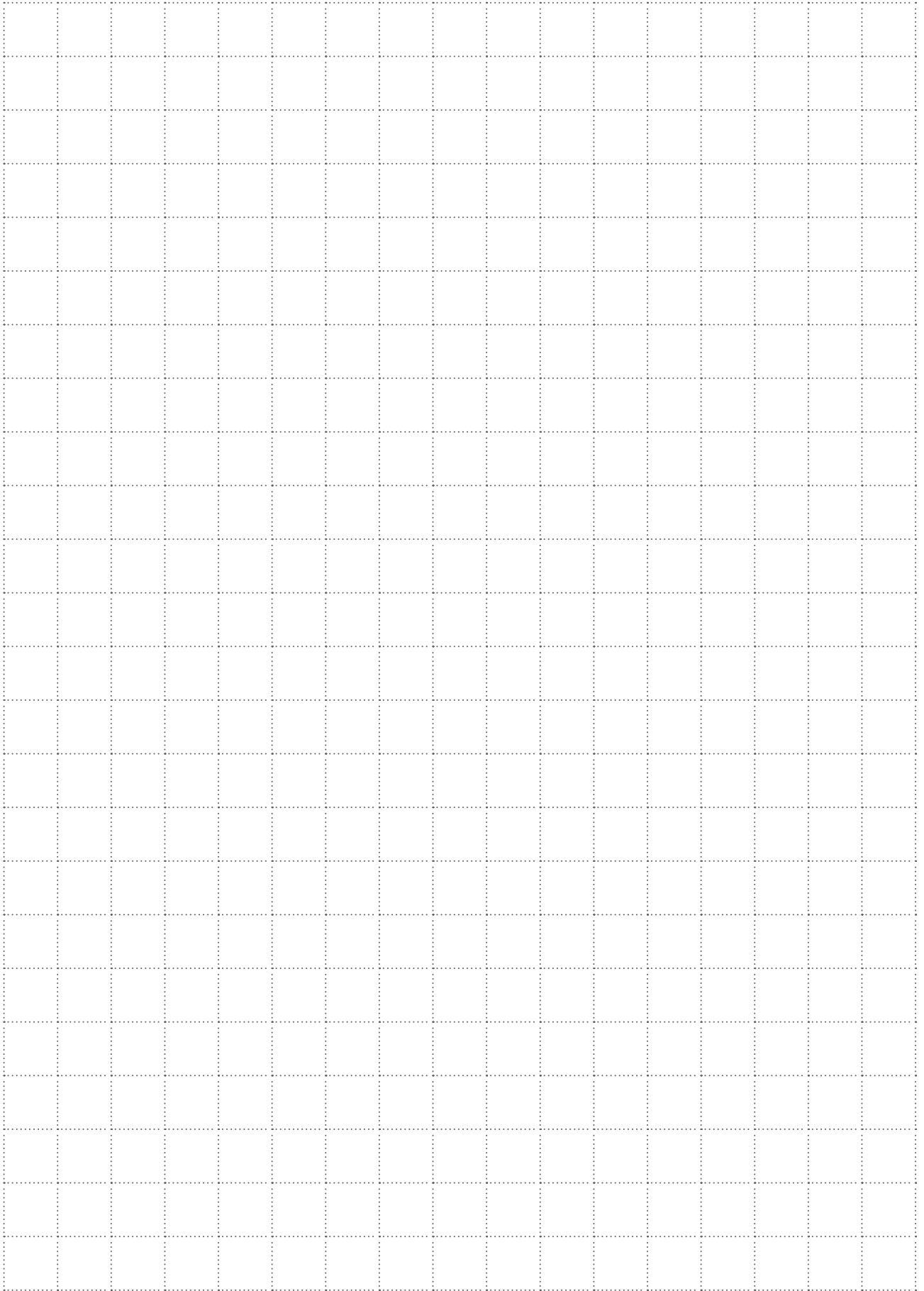

Airwell

As part of our ongoing product improvement programme, our products are subject to change without prior notice. Non contractual photos.



CAC Export Department
42 cours Jean-Jaurès
17800 Pons - France
Tel. : +33 (0)5 46 92 33 33 - Fax : +33 (0)5 46 91 26 44

Your distributor :