

► Air-to-Water Reverse Cycle Heat Pumps

CLH 182 to 602



41 to 131 kW



46 to 152 kW



Technical Brochure

TM CLH-A.5GB

Date : July 2006

Supersedes : TM CLH-A.4GB/12.05

Technical Features

General

The CLH air-to-water reverse cycle heat pumps have been designed to operate with the **HFC 407C** refrigerant.

They are complete with **two independent reversible refrigerant** circuits fitted with a high efficiency and low vibration level Scroll compressor on each circuit.

These units are suitable for outdoor installation on the roof of a building or on the ground.

All the CLH units are completely factory tested in compliance with the internal quality system specifications and procedures, and are ready for field installation.

The "Plug and Play" concept has been introduced in each CLH unit, thanks to the use of BMS compatible microprocessor-based control system and to the **integrated hydraulic module** supplied as optional on all versions of the CLH range.

Also, thanks to the versions and options available, the CLH air-to-water heat pumps can fit all the demands of the market.

The CLH range is available in **5 versions**; each version is composed of 9 sizes.

CLH STD : Standard version fitted with standard equipment intended for reliable operation. The CLH STD units cover a nominal cooling capacity range from 41 to 131 kW and a nominal heating capacity range from 46 to 152 kW.

CLH LN : Low noise version having same equipment as STD version, except that it is fitted with low speed type larger size fans. The CLH LN units cover a nominal cooling capacity range from 41 to 131 kW and a nominal heating capacity range from 46 to 152 kW.

CLH ELN : Extra low noise version fitted with greater heat exchange surface area condenser coils, very low speed type fans and a stepless fan speed controller. When the optional integrated hydraulic module is supplied with electric heaters (EH), the fan speed controller will be provided upon request, as optional, for external mounting to the unit. Furthermore, the ELN version is equipped with a reinforced soundproofing :

- mufflers mounted on compressor discharge lines (all sizes),
- soundproofing jacket on compressor (sizes 182 to 302),
- sound insulation on compressor compartment (sizes 352 to 602).

The CLH ELN units cover a nominal cooling capacity range from 41 to 131 kW and a nominal heating capacity range from 40 to 152 kW.

CLH HPF : High pressure fan version having same equipment as STD version, except that larger size fans with 80 Pa external static pressure are fitted on this HPF version. The CLH HPF units cover a nominal cooling capacity range from 41 to 131 kW and a nominal heating capacity range from 40 to 152 kW.

CLH SIF : Special inverter fan version having same equipment as STD version but with special axial fan equipped with brushless EC motor, fan speed stepless controlled by discharge pressure sensor fitted on both refrigerant circuits. Fan speed range from 50 to 1150 rpm. Special inverter fans provide nominal external static pressure up to 150 Pa, easily selectable on field by means of software. CLH SIF units are available in 5 sizes (352 to 602) and cover a nominal cooling capacity range from 88 to 131 kW and a nominal heating capacity range from 100 to 152 kW.

Reference standards

The following applies to all the sizes and versions belonging to the CLH units :

- ✓ Performance test EN 12055
- ✓ Machine Directive CEE 89 / 392
- ✓ Low Voltage Directive CEE 73/23 (EN 60204-1)
- ✓ Electromagnetic Compatibility Directive CEE 89/336 as modified by Directive CEE 92/31 (EN 50081-1, EN 50082-2)

Cabinet and structure

The unit structure shall be of heavy gauge galvanized steel fastened with non-corrosive screws and bolts. Galvanized steel parts shall be painted with baked on enamel colored white (RAL 9001).

Compressors

Each unit shall be equipped with 2 Scroll hermetic compressors.

Compressors on all models shall be mounted on rubber anti-vibration pads and have direct on line starting.

The compressor motors shall be refrigerant gas cooled, with integral thermistor protection against overloads. The overload protection is automatically reset.

The motor terminal boxes shall have IP-54 weather protection.

Evaporator

Evaporators are of a brazed stainless steel plate type heat exchanger. They are insulated with a closed cell foam material and are fitted with an electric cable resistance to prevent the unit from freezing at a low temperature when the unit is off.

Design working pressure shall be 10 bar on the water side and 30 bar on the refrigerant side.

Water connections are of a 2" gas male threaded type.

Condenser coils

The condenser coils shall be seamless copper tubes, arranged in staggered rows, mechanically expanded into corrugated aluminum fins.

Condenser coil fans

The condenser fans shall be direct drive with aluminum wing contour blades. Each fan will have a painted galvanized steel protection guard.

The totally enclosed fan motors shall have IP 54 degree of protection and thermo-contact protection embedded in their windings.

Fan controls

Each unit can be equipped, as optional , with a stepless fan speed controller, operating on the basis of condensing pressure, to keep fan rpm under control in order to operate in cooling mode at a low ambient temperature (-18 °C).

This fan speed controller is supplied as standard on the ELN units without extra electric heating resistances (EH) and as optional on ELN units with EH resistances. However, it is not available on HPF units.

Refrigerant circuits

All the units are composed of two independent and separate refrigerant circuits. All the components that constitute each circuit are shown on the functional diagram (see chapter "Refrigerant flow diagram").

Integrated hydraulic module (optional)

Units can be supplied with optional integrated hydraulic module composed of water tank and 1 or 2 pumps complete with accessories.

Antifreeze heater is supplied as standard in the tank.

The hydraulic module can be fitted, as optional, with an extra electric heating (EH).

Units can also be supplied with pump kit only (with 1 or 2 pumps).

Technical Features (continued)

Power and control panel

The control compartment shall contain an electronic circuit board and a key control panel with display of operating parameters, alarms and stops.

Thermal relays and fuses are supplied to protect compressors, fans and pumps from overloading.

Control and safety devices

Each CLH unit is fitted with the following devices :

Safety :

- ✓ Fan thermal protection.
- ✓ Compressor thermal protection.
- ✓ Water differential pressure switch.
- ✓ High pressure switch.
- ✓ Evaporator antifreeze protection.
- ✓ Low pressure switch.
- ✓ Crankcase heater.

Control :

- ✓ Evaporator water inlet temperature sensor.
- ✓ Evaporator water outlet temperature sensor.
- ✓ Coil temperature sensor.

Factory-installed accessories and options

- ✓ Coils with blue fins covered with a coating easing the flowing of water.
- ✓ Coils with "Silverguard" (polyurethane) coated fins.
- ✓ Coils with copper fins.
- ✓ LP & HP manometers.
- ✓ Condenser coil guards.
- ✓ Integrated hydraulic module with water tank, antifreeze resistance and 1 or 2 pumps.
- ✓ Extra electric heating for hydraulic module.
- ✓ Pump kit with 1 or 2 pumps.
- ✓ Compressor overload protection kit.
- ✓ Phase monitor.
- ✓ Stepless fan speed controller (STD and LN versions only).

Field-installed accessories

- ✓ Water filter.
- ✓ Flow switch.
- ✓ Spring anti-vibration mounts.
- ✓ Remote control kit (On/Off, Heating, Cooling).
- ✓ Modbus interface kit.
- ✓ Remote keyboard panel.
- ✓ Chiller sequencer (4 units maximum).

Control

Controller display panel

Remote control kit (optional)

LEDs	
1	Heating mode display
2	Cooling mode display
3	Operating mode selection
4	Unit On/Off; Alarm restoration
5	Display
6	Compressor 2 ON LED (Blink : time delay in progress)
7	Electric resistance ON LED
8	Compressor 1 ON LED (Blink : time delay in progress)
9	Voltage ON LED
10	Unit activated alarm LED
11	Start key and LED - Cooling
12	Start key and LED - Heating

The controller provides information on status of operation, configuration and alarms through a display and LEDs on the front panel.

Display

It allows mainly to show :

- the entering water temperature of the unit in tenths of degrees Celsius with a decimal point,
- the alarm code if at least one alarm is active.

If neither HEATING LED nor COOLING LED is ON, the controller is in STANDBY mode.

Refrigerant Flow Diagram

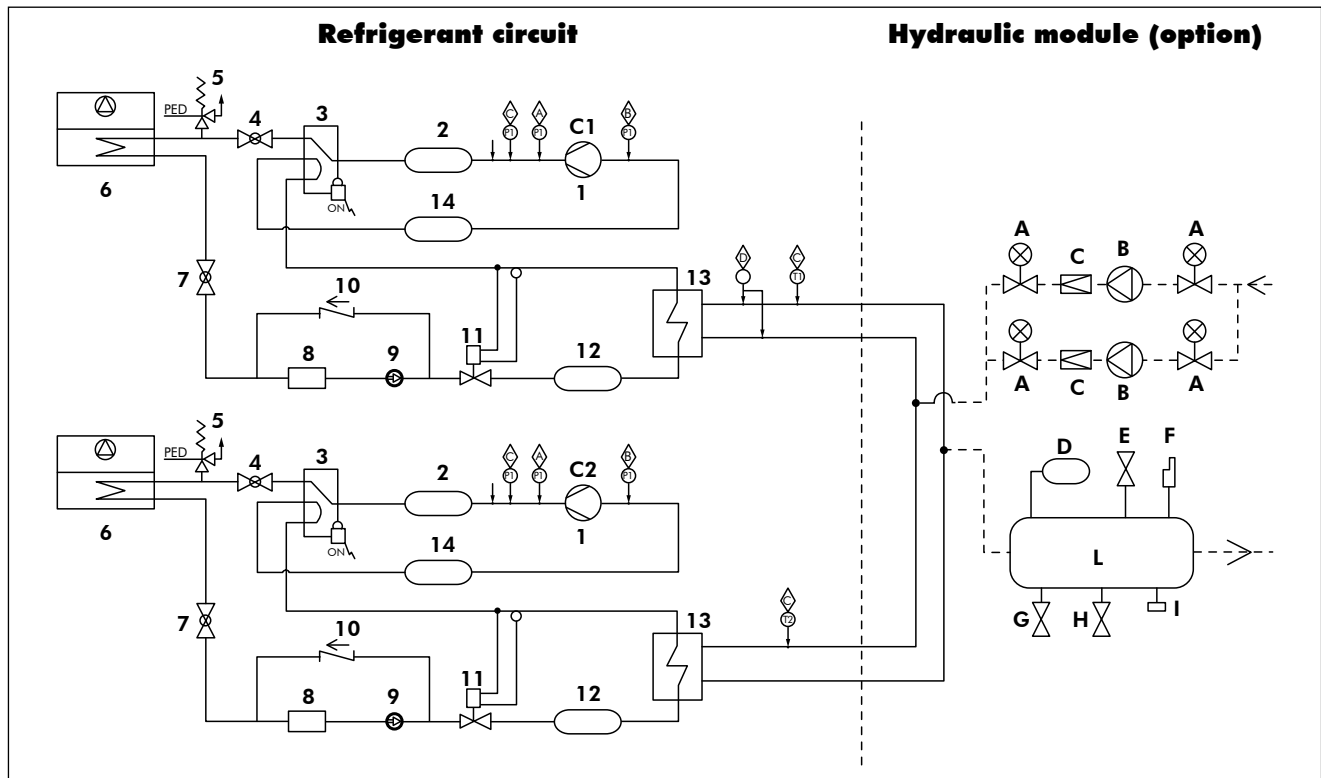

COMPONENTS (refrigerant circuits)		COMPONENTS (optional hydraulic module)		Safety / Control devices	
1	Compressors C1, C2	A	Shutoff valve	A	High pressure switch
2	Mufflers (for ELN version only)	B	Pump(s)	B	Low pressure switch
3	4-way valve	C	Check valve	C	Transducer (optional)
4	Discharge valve	D	Expansion tank	D	Water differential pressure switch
5	PED pressure relief valve	E	Relief valve	↓	Pressure tapping and refrigerant charging/discharging points
6	Air cooled condenser	F	Air vent		
7	Liquid valve	G	Filling up valve		
8	Filter drier	H	Drain valve		
9	Sight glass	I	Manometer		
10	Check valve	L	Water tank		
11	Expansion valve				
12	Liquid receiver				
13	Plate heat exchanger				
14	Suction accumulator				

Operating Limits

CLH 182 to 302

CLH			182		202		242		302	
			Min.	Max.	Min.	Max.	Min.	Max.	Min.	Max.
Chiller	Liquid outlet temperature	Water °C	+6 to +15							
		Brine (for low liquid temperature application) °C	-8 to +5							
		Temperature difference K	3 to 7							
	Flow rate	l/h	3902	9106	6731	15705	8268	19296	9656	22532
	Max. operating pressure - Water side	bar	10							
Ambient air	Air entering temperature	Cooling - STD °C	15	46	15	46	15	46	15	46
		Cooling - LN/HPF °C	15	46	15	46	15	46	15	46
		Cooling - ELN °C	-18	42	-18	42	-18	42	-18	42
		Heating °C	-5 to +15 °C							
	External static pressure	Standard fans Pa	0							
		High pressure fans - HPF version Pa	80							
Heat pump	°C	+30 to +50								
Recommended system chilled water volume	litres	200		280		330		370		
Nominal supply voltage		400 V / 3 Ph / 50 Hz (nominal)								

CLH 352 to 602

CLH			352		402		502		552		602	
			Min.	Max.	Min.	Max.	Min.	Max.	Min.	Max.	Min.	Max.
Chiller	Liquid outlet temperature	Water °C	+6 to +15									
		Brine (for low liquid temperature application) °C	-8 to +5									
		Temperature difference K	3 to 7									
	Flow rate	l/h	10800	25198	12126	28294	13563	31648	12997	37668	14126	37668
	Max. operating pressure - Water side	bar	10									
Ambient air	Air entering temperature	Cooling - STD °C	15	46	15	46	15	46	15	44	15	44
		Cooling - LN/HPF °C	15	46	15	46	15	46	15	44	15	44
		Cooling - ELN °C	-18	42	-18	42	-18	42	-18	42	-18	42
		Cooling - SIF °C	-18	48	-18	48	-18	48	-18	48	-18	48
	Heating °C	-5 to +15 °C										
	External static pressure	Standard fans Pa	0									
High pressure fans - HPF version Pa		80										
High pressure fans - SIF version Pa		150										
Heat pump	°C	+30 to +50										
Recommended system chilled water volume	litres	450		530		600		677		747		
Nominal supply voltage		400 V / 3 Ph / 50 Hz (nominal)										

Correction Factors

Fouling factors

EVAPORATOR			CONDENSER		
Fouling factor (m ² .°C/kW)	Cooling capacity factor	Power input factor	Fouling factor (m ² .°C/kW)	Cooling capacity factor	Power input factor
0.044	1.000	1.000	0.044	1.000	1.000
0.088	0.987	0.995	0.088	0.987	1.023
0.176	0.964	0.985	0.176	0.955	1.068
0.352	0.915	0.962	0.352	0.910	1.135

Altitude factors

Altitude (m)	Cooling capacity factor	Power input factor
0	1.000	1.000
600	0.987	1.010
1200	0.973	1.020
1800	0.958	1.029
2400	0.943	1.038

Ethylene glycol solution correction factors

Ethylene glycol percent by weight	%	10	20	30	35	40
Freezing point	°C	-4	-10	-17	-21	-25
Cooling capacity correction factors (1)		0.995	0.985	0.970	0.963	0.955
Power input correction factors (1)		0.998	0.995	0.985	0.983	0.980
Flow rate correction factors		1.015	1.050	1.085	1.123	1.160
Pressure drop correction factors (2)		1.070	1.160	1.235	1.283	1.330

(1) Factors applicable only for glycol solution leaving temperature ≥ 7 °C. For temperatures < 7 °C, refer to table "Low temperature operation correction factors".

(2) Factors applicable only for glycol solution leaving temperature > 5 °C. For temperatures < 5 °C, refer to table "Pressure drop correction factors for low temperature operation".

Low temperature operation correction factors

Leaving water temperature	°C	7	4	2	0	-2	-4	-6	-8
Minimum ethylene glycol percent	%	0	10	10	20	20	30	30	35
Cooling capacity correction factors		1.000	0.887	0.816	0.748	0.685	0.624	0.568	0.513
Power input correction factors		1.000	0.940	0.900	0.865	0.826	0.788	0.753	0.718

Pressure drop correction factors for low temperature operation

Ethylene glycol percent by weight	Glycol solution leaving temperature (°C)	Pressure drop correction factors
10%	5	1.071
	4	1.076
	3	1.081
	2	1.085
20%	1	1.193
	0	1.200
	-1	1.208
	-2	1.215
30%	-3	1.299
	-4	1.306
	-5	1.320
	-6	1.333

Physical Data - CLH STD / STD EH

CLH STD / STD EH sizes		182	202	242	302	352	402	502	552	602
Nominal cooling capacity (1)	kW	40.8	54.8	67.3	78.6	87.9	98.7	110.4	120.9	131.4
Compressor power input - Cooling	kW	12.5	17.5	24.6	28.0	33.6	35.0	42.0	49.4	56.7
Maximum power input (3)	kW	18.8	25.4	31.0	36.0	42.1	49.9	57.6	64.7	71.8
EER		3.3	3.1	2.7	2.8	2.6	2.8	2.6	2.4	2.3
Nominal heating capacity (2)	kW	45.7	58.0	77.4	90.4	101.0	113.5	127.0	139.7	152.4
Compressor power input - Heating	kW	10.9	17.2	25.1	29.0	31.6	35.3	41.3	47.5	53.6
Number of refrigerant circuits		2	2	2	2	2	2	2	2	2
Capacity steps	%	50/100	50/100	50/100	50/100	43-57/100	50/100	50/100	43-57/100	50/100
REFRIGERANT										
Type		HFC 407C								
Charge	kg	7	11	13	14.5	15	17	20	22	24
COMPRESSORS										
Number		2	2	2	2	2	2	2	2	2
Type		Scroll	Scroll	Scroll	Scroll	Scroll	Scroll	Scroll	Scroll	Scroll
EVAPORATORS										
Number		2	2	2	2	2	2	2	2	2
Type		Plate	Plate	Plate	Plate	Plate	Plate	Plate	Plate	Plate
Antifreeze heater power input	W	2 x 35	2 x 35	2 x 35	2 x 35	2 x 35	2 x 35	2 x 35	2 x 35	2 x 35
AIR COOLED CONDENSERS										
Number		2	2	2	2	2	2	2	2	2
Total face area per coil	m ²	2.1	2.1	2.1	2.85	3.6	3.6	3.6	3.6	3.6
Number of rows		2	3	4	3	3	4	4	5	5
FANS										
Number		2	2	2	3	3	3	3	3	3
Total air flow	m ³ /h	21000	21000	21000	31700	32400	32100	32100	32100	32100
Power input	kW	0.96	0.96	0.96	1.44	1.44	1.44	1.44	1.44	1.44
WATER CONNECTIONS										
Type		Male gas threaded								
Inlet diameter	inch	2"	2"	2"	2"	2"	2"	2"	2"	2"
Outlet diameter	inch	2"	2"	2"	2"	2"	2"	2"	2"	2"
DIMENSIONS										
Length	mm	2110	2110	2110	2760	3110	3110	3110	3110	3110
Width	mm	1110	1110	1110	1110	1110	1110	1110	1110	1110
Height	mm	1750	1750	1750	1750	1750	1750	1750	1750	1750
WEIGHT										
Basic - Shipping / Operating	kg	640 / 650	690 / 700	850 / 860	900 / 910	1000 / 1010	1150 / 1160	1150 / 1160	1285 / 1295	1320 / 1330
1 pump - Shipping / Operating	kg	672 / 682	722 / 732	882 / 892	932 / 942	1032 / 1042	1182 / 1192	1182 / 1192	1317 / 1327	1352 / 1362
2 pumps - Shipping / Operating	kg	692 / 702	742 / 752	902 / 912	952 / 962	1052 / 1062	1202 / 1212	1202 / 1212	1337 / 1347	1372 / 1382
Water tank+1 pump - Shipping / Operating	kg	737 / 947	787 / 997	947 / 1157	1032 / 1362	1152 / 1552	1302 / 1702	1302 / 1702	1437 / 1837	1472 / 1872
Water tank+2 pumps - Shipping / Operating	kg	757 / 967	807 / 1017	967 / 1177	1052 / 1382	1172 / 1572	1322 / 1722	1322 / 1722	1457 / 1857	1492 / 1892
SOUND LEVELS										
Sound power levels	dB(A)	86	86	87	87	89	91	91	95	95
Sound pressure levels at 10 meters (4)	dB(A)	54	54	55	55	57	59	59	63	63

(1) Data based on 7 °C leaving chilled water temperature and 35 °C ambient air temperature.

(2) Data based on 45 °C leaving hot water temperature and 7 °C ambient air temperature.

(3) Maximum power input includes : maximum compressor power input and maximum fan power input.

(4) Sound pressure level values refer to ISO standard 3744.

Physical Data - CLH LN / LN EH

CLH LN / LN EH sizes		182	202	242	302	352	402	502	552	602
Nominal cooling capacity (1)	kW	40.8	54.8	67.3	78.6	87.9	98.7	110.4	120.9	131.4
Compressor power input - Cooling	kW	12.5	17.5	24.6	28.0	33.6	35.0	42.0	49.4	56.7
Maximum power input (3)	kW	19.3	25.9	31.4	36.7	42.8	50.6	58.3	65.4	72.5
EER		3.3	3.1	2.7	2.8	2.6	2.8	2.6	2.4	2.3
Nominal heating capacity (2)	kW	45.7	58.0	77.4	90.4	101.0	113.5	127.0	139.7	152.4
Compressor power input - Heating	kW	10.9	17.2	25.1	29.0	31.6	35.3	41.3	47.5	53.6
Number of refrigerant circuits		2	2	2	2	2	2	2	2	2
Capacity steps	%	50/100	50/100	50/100	50/100	43-57/100	50/100	50/100	43-57/100	50/100
REFRIGERANT										
Type		HFC 407C								
Charge	kg	7	11	13	14.5	15	17	20	22	24
COMPRESSORS										
Number		2	2	2	2	2	2	2	2	2
Type		Scroll	Scroll	Scroll	Scroll	Scroll	Scroll	Scroll	Scroll	Scroll
EVAPORATORS										
Number		2	2	2	2	2	2	2	2	2
Type		Plate	Plate	Plate	Plate	Plate	Plate	Plate	Plate	Plate
Antifreeze heater power input	W	2 x 35	2 x 35	2 x 35	2 x 35	2 x 35	2 x 35	2 x 35	2 x 35	2 x 35
AIR COOLED CONDENSERS										
Number		2	2	2	2	2	2	2	2	2
Total face area per coil	m ²	2.1	2.1	2.1	2.85	3.6	3.6	3.6	3.6	3.6
Number of rows		2	3	4	3	3	4	4	5	5
FANS										
Number		2	2	2	3	3	3	3	3	3
Total air flow	m ³ /h	22650	22650	22650	34400	35800	34700	34700	34700	34700
Power input	kW	1.4	1.4	1.4	2.1	2.1	2.1	2.1	2.1	2.1
WATER CONNECTIONS										
Type		Male gas threaded								
Inlet diameter	inch	2"	2"	2"	2"	2"	2"	2"	2"	2"
Outlet diameter	inch	2"	2"	2"	2"	2"	2"	2"	2"	2"
DIMENSIONS										
Length	mm	2100	2100	2100	2760	3110	3110	3110	3110	3110
Width	mm	1110	1110	1110	1110	1110	1110	1110	1110	1110
Height	mm	1850	1850	1850	1850	1850	1850	1850	1850	1850
WEIGHT										
Basic - Shipping / Operating	kg	640 / 650	690 / 700	850 / 860	900 / 910	1000 / 1010	1150 / 1160	1150 / 1160	1285 / 1295	1320 / 1330
1 pump - Shipping / Operating	kg	672 / 682	722 / 732	882 / 892	932 / 942	1032 / 1042	1182 / 1192	1182 / 1192	1317 / 1327	1352 / 1362
2 pumps - Shipping / Operating	kg	692 / 702	742 / 752	902 / 912	952 / 962	1052 / 1062	1202 / 1212	1202 / 1212	1337 / 1347	1372 / 1382
Water tank+1 pump - Shipping / Operating	kg	737 / 947	787 / 997	947 / 1157	1032 / 1362	1152 / 1552	1302 / 1702	1302 / 1702	1437 / 1837	1472 / 1872
Water tank+2 pumps - Shipping / Operating	kg	757 / 967	807 / 1017	967 / 1177	1052 / 1382	1172 / 1572	1322 / 1722	1322 / 1722	1457 / 1857	1492 / 1892
SOUND LEVELS										
Sound power levels	dB(A)	83	83	84	85	87	87	87	87	87
Sound pressure levels at 10 meters (4)	dB(A)	51	51	52	53	55	55	55	55	55

(1) Data based on 7 °C leaving chilled water temperature and 35 °C ambient air temperature.

(2) Data based on 45 °C leaving hot water temperature and 7 °C ambient air temperature.

(3) Maximum power input includes : maximum compressor power input and maximum fan power input.

(4) Sound pressure level values refer to ISO standard 3744.

Physical Data - CLH ELN / ELN EH

CLH ELN / ELN EH sizes		182	202	242	302	352	402	502	552	602
Nominal cooling capacity (1)	kW	40.8	54.1	64.5	71.4	87.0	93.0	104.2	120.9	131.4
Compressor power input - Cooling	kW	12.3	18.2	25.9	31.8	33.9	39.4	47.0	49.4	56.7
Maximum power input (3)	kW	19.3	25.9	31.4	36.0	42.8	50.6	58.3	65.4	72.5
EER		3.3	3.0	2.5	2.2	2.6	2.4	2.2	2.4	2.3
Nominal heating capacity (2)	kW	40.4	54.8	74.2	82.0	100.0	106.0	122.0	139.7	152.4
Compressor power input - Heating	kW	12.6	17.2	25.0	28.8	31.6	35.2	41.2	47.5	53.6
Number of refrigerant circuits		2	2	2	2	2	2	2	2	2
Capacity steps	%	50/100	50/100	50/100	50/100	43-57/100	50/100	50/100	43-57/100	50/100
REFRIGERANT										
Type		HFC 407C								
Charge	kg	9	12	15	15	15	17	20	22	24
COMPRESSORS										
Number		2	2	2	2	2	2	2	2	2
Type		Scroll	Scroll	Scroll	Scroll	Scroll	Scroll	Scroll	Scroll	Scroll
EVAPORATORS										
Number		2	2	2	2	2	2	2	2	2
Type		Plate	Plate	Plate	Plate	Plate	Plate	Plate	Plate	Plate
Antifreeze heater power input	W	2 x 35	2 x 35	2 x 35	2 x 35	2 x 35	2 x 35	2 x 35	2 x 35	2 x 35
AIR COOLED CONDENSERS										
Number		2	2	2	2	2	2	2	2	2
Total face area per coil	m ²	2.1	2.1	2.85	2.85	3.6	3.6	3.6	3.6	3.6
Number of rows		3	4	4	4	4	4	4	5	5
FANS										
Number		2	2	3 (2xEH)	3 (2xEH)	3 (2xEH)	3	3	3	3
Total air flow	m ³ /h	15000	14250	14250	14250	11250	24000	24000	23500	23500
Power input	kW	1.4	1.4	2.1(1.4xEH)	2.1(1.4xEH)	2.1(1.4xEH)	2.1	2.1	2.1	2.1
WATER CONNECTIONS										
Type		Male gas threaded								
Inlet diameter	inch	2"	2"	2"	2"	2"	2"	2"	2"	2"
Outlet diameter	inch	2"	2"	2"	2"	2"	2"	2"	2"	2"
DIMENSIONS										
Length	mm	2100	2100	2760	2760	3110	3110	3110	3110	3110
Width	mm	1110	1110	1110	1110	1110	1110	1110	1110	1110
Height	mm	1850	1850	1850	1850	1850	1850	1850	1850	1850
WEIGHT										
Basic - Shipping / Operating	kg	660 / 670	710 / 720	900 / 910	950 / 960	1120 / 1130	1170 / 1180	1170 / 1180	1305 / 1315	1340 / 1350
1 pump - Shipping / Operating	kg	692 / 702	742 / 752	932 / 942	982 / 992	1152 / 1162	1202 / 1212	1202 / 1212	1337 / 1347	1372 / 1382
2 pumps - Shipping / Operating	kg	712 / 722	762 / 772	952 / 962	1002 / 1012	1172 / 1182	1222 / 1232	1222 / 1232	1357 / 1367	1392 / 1402
Water tank+1 pump - Shipping / Operating	kg	757 / 967	807 / 1017	1032 / 1362	1082 / 1412	1272 / 1672	1322 / 1436	1322 / 1722	1457 / 1857	1492 / 1892
Water tank+2 pumps - Shipping / Operating	kg	777 / 987	827 / 1037	1052 / 1382	1102 / 1432	1292 / 1692	1342 / 1742	1342 / 1742	1477 / 1877	1512 / 1912
SOUND LEVELS										
Sound power levels	dB(A)	78	78	79	80	81.5	83	83	83	83
Sound pressure levels at 10 meters (4)	dB(A)	46	46	47	48	49.5	51	51	51	51

(1) Data based on 7 °C leaving chilled water temperature and 35 °C ambient air temperature.

(2) Data based on 45 °C leaving hot water temperature and 7 °C ambient air temperature.

(3) Maximum power input includes : maximum compressor power input and maximum fan power input.

(4) Sound pressure level values refer to ISO standard 3744.

Physical Data - CLH HPF / HPF EH

CLH HPF / HPF EH sizes		182	202	242	302	352	402	502	552	602
Nominal cooling capacity (1)	kW	40.8	54.8	67.3	78.6	87.9	98.7	110.4	120.9	131.4
Compressor power input - Cooling	kW	12.5	17.5	24.6	28.0	33.6	35.0	42.0	49.4	56.7
Maximum power input (3)	kW	19.8	26.4	32.0	37.5	43.6	51.4	59.1	64.7	71.8
EER		3.3	3.1	2.7	2.8	2.6	2.8	2.6	2.4	2.3
Nominal heating capacity (2)	kW	40.4	54.8	74.2	82.0	100.0	106.0	122.0	139.7	152.4
Compressor power input - Heating	kW	12.6	17.2	25.0	28.8	31.6	35.2	41.2	47.5	53.6
Number of refrigerant circuits		2	2	2	2	2	2	2	2	2
Capacity steps	%	50/100	50/100	50/100	50/100	43-57/100	50/100	50/100	43-57/100	50/100
REFRIGERANT										
Type		HFC 407C								
Charge	kg	9	12	15	15	15	17	20	22	24
COMPRESSORS										
Number		2	2	2	2	2	2	2	2	2
Type		Scroll	Scroll	Scroll	Scroll	Scroll	Scroll	Scroll	Scroll	Scroll
EVAPORATORS										
Number		2	2	2	2	2	2	2	2	2
Type		Plate	Plate	Plate	Plate	Plate	Plate	Plate	Plate	Plate
Antifreeze heater power input	W	2 x 35	2 x 35	2 x 35	2 x 35	2 x 35	2 x 35	2 x 35	2 x 35	2 x 35
AIR COOLED CONDENSERS										
Number		2	2	2	2	2	2	2	2	2
Total face area per coil	m ²	2.1	2.1	2.1	2.85	3.6	3.6	3.6	3.6	3.6
Number of rows		2	3	4	3	3	4	4	5	5
FANS										
Number		2	2	2	3	3	3	3	3	3
Total air flow	m ³ /h	21000	21000	21000	31700	32400	32100	32100	32100	32100
Power input	kW	1.96	1.96	1.96	2.94	2.94	2.94	2.94	2.94	2.94
WATER CONNECTIONS										
Type		Male gas threaded								
Inlet diameter	inch	2"	2"	2"	2"	2"	2"	2"	2"	2"
Outlet diameter	inch	2"	2"	2"	2"	2"	2"	2"	2"	2"
DIMENSIONS										
Length	mm	2100	2100	2760	2760	3110	3110	3110	3110	3110
Width	mm	1110	1110	1110	1110	1110	1110	1110	1110	1110
Height	mm	1850	1850	1850	1850	1850	1850	1850	1850	1850
WEIGHT										
Basic - Shipping / Operating	kg	640 / 650	690 / 700	850 / 860	900 / 910	1000 / 1010	1150 / 1160	1150 / 1160	1285 / 1295	1320 / 1330
1 pump - Shipping / Operating	kg	672 / 682	722 / 732	882 / 892	932 / 942	1032 / 1042	1182 / 1192	1182 / 1192	1317 / 1327	1352 / 1362
2 pumps - Shipping / Operating	kg	692 / 702	742 / 752	902 / 912	952 / 962	1052 / 1062	1202 / 1212	1202 / 1212	1337 / 1347	1372 / 1382
Water tank+1 pump - Shipping / Operating	kg	737 / 947	787 / 997	947 / 1157	1032 / 1362	1152 / 1552	1302 / 1702	1302 / 1702	1437 / 1837	1472 / 1872
Water tank+2 pumps - Shipping / Operating	kg	757 / 967	807 / 1017	967 / 1177	1052 / 1382	1172 / 1572	1322 / 1722	1322 / 1722	1457 / 1857	1492 / 1892
SOUND LEVELS										
Sound power levels	dB(A)	89	89	90	90	92	94	94	94	94
Sound pressure levels at 10 meters (4)	dB(A)	57	57	58	58	60	62	62	62	62

(1) Data based on 7 °C leaving chilled water temperature and 35 °C ambient air temperature.

(2) Data based on 45 °C leaving hot water temperature and 7 °C ambient air temperature.

(3) Maximum power input includes : maximum compressor power input and maximum fan power input.

(4) Sound pressure level values refer to ISO standard 3744.

Physical Data - CLH SIF

CLH SIF sizes		352	402	502	552	602
Nominal cooling capacity (1)	kW	87.9	98.7	110.4	120.9	131.4
Compressor power input - Cooling	kW	33.6	35.0	42.0	49.4	56.7
Maximum power input (3)	kW	43.6	51.4	59.1	64.7	71.8
EER		2.6	2.8	2.6	2.4	2.3
Nominal heating capacity (2)	kW	100.0	106.0	122.0	139.7	152.4
Compressor power input - Heating	kW	31.6	35.2	41.2	47.5	53.6
Number of refrigerant circuits		2	2	2	2	2
Capacity steps	%	43-57/100	50/100	50/100	43-57/100	50/100
REFRIGERANT						
Type		HFC 407C				
Charge	kg	15	17	20	22	24
COMPRESSORS						
Number		2	2	2	2	2
Type		Scroll	Scroll	Scroll	Scroll	Scroll
EVAPORATORS						
Number		2	2	2	2	2
Type		Plate	Plate	Plate	Plate	Plate
Antifreeze heater power input	W	2 x 35	2 x 35	2 x 35	2 x 35	2 x 35
AIR COOLED CONDENSERS						
Number		2	2	2	2	2
Total face area per coil	m ²	3.6	3.6	3.6	3.6	3.6
Number of rows		3	4	4	5	5
FANS						
Number		2	2	2	2	2
Total air flow	m ³ /h	32400	32100	32100	32100	32100
Power input	kW	5.2	5.2	5.2	5.2	5.2
WATER CONNECTIONS						
Type		Male gas threaded				
Inlet diameter	inch	2"	2"	2"	2"	2"
Outlet diameter	inch	2"	2"	2"	2"	2"
DIMENSIONS						
Length	mm	3110	3110	3110	3110	3110
Width	mm	1110	1110	1110	1110	1110
Height	mm	1850	1850	1850	1850	1850
WEIGHT						
Basic - Shipping / Operating	kg	1000 / 1010	1150 / 1160	1150 / 1160	1285 / 1295	1320 / 1330
1 pump - Shipping / Operating	kg	1032 / 1042	1182 / 1192	1182 / 1192	1317 / 1327	1352 / 1362
2 pumps - Shipping / Operating	kg	1052 / 1062	1202 / 1212	1202 / 1212	1337 / 1347	1372 / 1382
Water tank+1 pump - Shipping / Operating	kg	1152 / 1552	1302 / 1702	1302 / 1702	1437 / 1837	1472 / 1872
Water tank+2 pumps - Shipping / Operating	kg	1172 / 1572	1322 / 1722	1322 / 1722	1457 / 1857	1492 / 1892
SOUND LEVELS						
Sound power levels	dB(A)	92.5	94	94	95	95
Sound pressure levels at 10 meters (4)	dB(A)	60.5	62	62	63	63

(1) Data based on 7 °C leaving chilled water temperature and 35 °C ambient air temperature.

(2) Data based on 45 °C leaving hot water temperature and 7 °C ambient air temperature.

(3) Maximum power input includes : maximum compressor power input and maximum fan power input.

(4) Sound pressure level values refer to ISO standard 3744.

Fan External Static Pressure - CLH SIF

Sizes	External static pressure (Pa)	Fan speed (rpm)	Sound power levels (dBA)
CLH 352	50	900	91
	80	950	91
	100	1000	91
	130	1050	92,5
	150	1100	94
	185	1150	95
CLH 402	50	900	91
	80	950	91
	100	1000	91
	130	1050	92,5
	150	1100	94
	185	1150	95
CLH 502	32	900	91
	65	950	91
	95	1000	91
	120	1050	92,5
	150	1100	94
	180	1150	95
CLH 552	22	900	91
	55	950	91
	85	1000	91
	110	1050	92,5
	150	1100	94
	170	1150	95
CLH 602	22	900	91
	55	950	91
	85	1000	91
	110	1050	92,5
	150	1100	94
	170	1150	95

Electrical Data

Compressors @ 400 V / 3 Ph / 50 Hz

CLH Models		Power input at nominal conditions per compressor (kW)	Current at nominal conditions per compressor (A)	Power input at max. conditions per compressor (kW)	Current at max. conditions per compressor FLA (A)	Start up current LRA (A)	Power factor at nominal conditions	Crankcase heater @ 230 V/1Ø (W)	Unit fuse size (A)	Cable section (mm ²)
182	Circuit 1	6	10.1	9	15	99	0.84	70	50	16
	Circuit 2	6	10.1	9	15	99	0.84	70		
202	Circuit 1	8.5	14.4	12	21	127	0.84	70	63	25
	Circuit 2	8.5	14.4	12	21	127	0.84	70		
242	Circuit 1	12	20	15	24	150	0.87	65	63	25
	Circuit 2	12	20	15	24	150	0.87	65		
302	Circuit 1	13.7	24.3	17	29	175	0.81	75	80	35
	Circuit 2	13.7	24.3	17	29	175	0.81	75		
352	Circuit 1	12.9	21.8	16	28	198	0.84	70	100	35
	Circuit 2	15.8	26.7	24	41	225	0.84	120		
402	Circuit 1	15.8	26.7	24	41	225	0.84	120	100	35
	Circuit 2	15.8	26.7	24	41	225	0.84	120		
502	Circuit 1	18.8	31.8	28	48	272	0.84	150	125	50
	Circuit 2	18.8	31.8	28	48	272	0.84	150		
552	Circuit 1	20.3	34.3	28	48	272	0.84	150	125	70
	Circuit 2	25.3	44.2	35	58.5	320	0.83	150		
602	Circuit 1	25.3	44.2	35	58.5	320	0.83	150	160	70
	Circuit 2	25.3	44.2	35	58.5	320	0.83	150		

Units @ 400 V / 3 Ph / 50 Hz

CLH STD Models		182	202	242	302	352	402	502	552	602
Nominal current input	A	22.2	30.6	41.9	51.4	51.3	56.2	66.4	81.3	91.2
Maximum current input	A	32.1	43.3	49.9	60.8	71.6	84.8	97.8	108.8	119.8
Nominal power input	kW	13.0	18.0	25.0	28.8	30.1	33.0	39.0	47.0	52.0
Maximum power input	kW	18.8	25.4	31.0	36.0	42.1	49.9	57.6	64.7	71.8
Starting current (LRA)	A	116	150	176	207	256	269	322	370	381

CLH LN Models		182	202	242	302	352	402	502	552	602
Nominal current input	A	22.6	31.0	42.3	52.1	52.0	56.9	67.0	82.0	91.9
Maximum current input	A	32.5	43.7	50.3	61.5	72.3	85.5	98.5	109.5	120.5
Nominal power input	kW	13.4	18.4	25.4	29.5	30.8	33.7	39.7	47.7	52.7
Maximum power input	kW	19.3	25.9	31.4	36.7	42.8	50.6	58.3	65.4	72.5
Starting current (LRA)	A	116	150	176	207	256	269	323	371	382

CLH ELN Models		182	202	242	302	352	402	502	552	602
Nominal current input	A	22.6	31.0	43.5	52.1	52.0	56.9	67.0	82.0	91.9
Maximum current input	A	32.5	43.7	51.5	61.5	72.3	85.5	98.5	109.5	120.5
Nominal power input	kW	13.4	18.4	26.1	29.5	30.8	33.7	39.7	47.7	52.7
Maximum power input	kW	19.3	25.9	32.1	36.7	42.8	50.6	58.3	65.4	72.5
Starting current (LRA)	A	116	150	177	207	256	269	323	371	382

CLH HPF Models		182	202	242	302	352	402	502	552	602
Nominal current input	A	23.7	32.1	43.4	53.7	53.6	58.5	73.8	83.6	93.5
Maximum current input	A	33.6	44.8	51.4	63.1	73.9	87.1	100.1	111.1	122.1
Nominal power input	kW	14.0	19.0	26.0	30.3	31.6	34.5	43.5	48.5	53.5
Maximum power input	kW	19.8	26.4	32.0	37.5	43.6	51.4	59.1	66.2	73.3
Starting current (LRA)	A	118	151	177	209	258	271	325	373	384

CLH SIF Models		352	402	502	552	602
Nominal current input	A	57.5	62.4	77.7	87.5	97.4
Maximum current input	A	77.8	91.0	104.0	118.5	133.0
Nominal power input	kW	33.9	36.8	45.8	50.8	55.8
Maximum power input	kW	45.9	53.7	61.4	68.5	75.6
Starting current (LRA)	A	262	275	329	377	391

Electrical Data (continued)

Units @ 400 V / 3 Ph / 50 Hz

CLH STD Models with pump		182	202	242	302	352	402	502	552	602
Nominal current input	A	24.3	32.7	45.7	55.2	56.2	61.1	71.3	86.2	96.1
Maximum current input	A	34.2	45.4	53.7	64.6	76.5	89.7	102.7	113.7	124.7
Nominal power input	kW	13.8	18.8	26.5	30.3	31.9	34.8	40.8	48.8	53.8
Maximum power input	kW	19.6	26.2	32.5	37.5	43.9	51.7	59.4	66.5	73.6
Starting current (LRA)	A	118	152	180	211	260	274	327	375	386

CLH LN Models with pump		182	202	242	302	352	402	502	552	602
Nominal current input	A	24.7	33.1	46.1	55.9	56.9	61.8	71.9	86.9	96.8
Maximum current input	A	34.6	45.8	54.1	65.3	77.2	90.4	103.4	114.4	125.4
Nominal power input	kW	14.2	19.2	26.9	31.0	32.6	35.5	41.5	49.5	54.5
Maximum power input	kW	20.1	26.7	32.9	38.2	44.6	52.4	60.1	67.2	74.3
Starting current (LRA)	A	119	152	180	211	261	274	328	376	387

CLH ELN Models with pump		182	202	242	302	352	402	502	552	602
Nominal current input	A	24.7	33.1	47.3	55.9	56.9	61.8	71.9	86.9	96.8
Maximum current input	A	34.6	45.8	55.3	65.3	77.2	90.4	103.4	114.4	125.4
Nominal power input	kW	14.2	19.2	27.6	31.0	32.6	35.5	41.5	49.5	54.5
Maximum power input	kW	20.1	26.7	33.6	38.2	44.6	52.4	60.1	67.2	74.3
Starting current (LRA)	A	119	152	181	211	261	274	328	376	387

CLH HPF Models with pump		182	202	242	302	352	402	502	552	602
Nominal current input	A	25.8	34.2	47.2	57.5	58.5	63.4	78.7	88.5	98.4
Maximum current input	A	35.7	46.9	55.2	66.9	78.8	92.0	105.0	116.0	127.0
Nominal power input	kW	14.8	19.8	27.5	31.8	33.4	36.3	45.3	50.3	55.3
Maximum power input	kW	20.6	27.2	33.5	39.0	45.4	53.2	60.9	68.0	75.1
Starting current (LRA)	A	120	153	181	213	263	276	330	378	389

CLH SIF Models with pump		352	402	502	552	602
Nominal current input	A	62.4	67.3	82.6	92.4	102.3
Maximum current input	A	82.7	95.9	108.9	123.4	137.9
Nominal power input	kW	35.7	38.6	47.6	52.6	57.6
Maximum power input	kW	47.7	55.5	63.2	70.3	77.4
Starting current (LRA)	A	267	280	333	381	396

CLH EH Models (Option 0) *		182	202	242	302	352	402	502	552	602
Nominal current input	A	58.9	67.3	91.9	101.4	102.4	130.3	140.5	156.8	166.7
Maximum current input	A	68.8	80.0	99.9	110.8	122.7	158.9	171.9	187.8	202.3
Nominal power input	kW	37.8	42.8	58.5	62.3	63.9	82.8	88.8	97.5	102.5
Maximum power input	kW	43.6	50.2	64.5	69.5	75.9	99.7	107.4	115.2	122.3
Starting current (LRA)	A	153	186	226	257	307	343	396	446	460

CLH EH Models (Option 1) *		182	202	242	302	352	402	502	552	602
Nominal current input	A	70.5	78.9	114.9	124.4	125.4	141.9	152.1	168.4	178.3
Maximum current input	A	80.4	91.6	122.9	133.8	145.7	170.5	183.5	199.4	213.9
Nominal power input	kW	45.8	50.8	74.5	78.3	79.9	90.8	96.8	105.5	110.5
Maximum power input	kW	51.6	58.2	80.5	85.5	91.9	107.7	115.4	123.2	130.3
Starting current (LRA)	A	164	198	249	280	330	354	408	457	472

CLH EH Models (Option 2) *		182	202	242	302	352	402	502	552	602
Nominal current input	A	93.5	101.9	126.5	136.0	137.0	153.5	163.7	180.0	189.9
Maximum current input	A	103.4	114.6	134.5	145.4	157.3	182.1	195.1	211.0	225.5
Nominal power input	kW	61.8	66.8	82.5	86.3	87.9	98.8	104.8	113.5	118.5
Maximum power input	kW	67.6	74.2	88.5	93.5	99.9	115.7	123.4	131.2	138.3
Starting current (LRA)	A	187	221	260	291	341	366	420	469	484

* Data given for all versions.

Pump(s)

CLH Models	Units with 1 pump		Units with 2 pumps	
	kW	A	kW	A
182	0.8	1.7	2 x 0.8	2 x 2.1
202	0.8	1.7	2 x 0.8	2 x 2.1
242	1.1	3.1	2 x 1.5	2 x 3.8
302	1.1	3.1	2 x 1.5	2 x 3.8
352	1.5	3.8	2 x 1.8	2 x 4.9
402	1.8	4.9	2 x 1.8	2 x 4.9
502	1.8	4.9	2 x 1.8	2 x 4.9
552	1.8	4.9	2 x 1.8	2 x 4.9
602	1.8	4.9	2 x 1.8	2 x 4.9

Sound Levels

Sound power levels Lw-dB(A)

CLH STD sizes	Frequencies (Hz)							Lw global dB(A)
	125	250	500	1000	2000	4000	8000	
182 STD	86	84	83	82	80	70	59	86
202 STD	86	84	83	82	80	70	59	86
242 STD	87	85	84	83	81	71	60	87
302 STD	87	85	84	83	81	71	60	87
352 STD	89	87	86	85	83	73	62	89
402 STD	89	87	86	85	83	73	62	91
502 STD	90	88	87	86	84	74	63	91
552 STD	94	92	91	90	88	78	67	95
602 STD	94	92	91	90	88	78	67	95

Sound pressure levels Lp-dB(A)

CLH STD sizes	Frequencies (Hz)							Lp* global dB(A)
	125	250	500	1000	2000	4000	8000	
182 STD	54	52	51	50	48	38	27	54
202 STD	54	52	51	50	48	38	27	54
242 STD	55	53	52	51	49	39	28	55
302 STD	55	53	52	51	49	39	28	55
352 STD	57	55	54	53	51	41	30	57
402 STD	57	55	54	53	51	41	30	59
502 STD	58	56	55	54	52	42	31	59
552 STD	62	60	59	58	56	46	35	63
602 STD	62	60	59	58	56	46	35	63

CLH LN sizes	Frequencies (Hz)							Lw global dB(A)
	125	250	500	1000	2000	4000	8000	
182 LN	83	81	80	79	77	67	56	83
202 LN	83	81	80	79	77	67	56	83
242 LN	84	82	81	80	78	68	57	84
302 LN	85	83	82	81	79	69	58	85
352 LN	87	85	84	83	81	71	60	87
402 LN	87	85	84	83	81	71	60	87
502 LN	87	85	84	83	81	71	60	87
552 LN	87	85	84	83	81	71	60	87
602 LN	87	85	84	83	81	71	60	87

CLH LN sizes	Frequencies (Hz)							Lp* global dB(A)
	125	250	500	1000	2000	4000	8000	
182 LN	51	49	48	47	45	35	24	51
202 LN	51	49	48	47	45	35	24	51
242 LN	52	50	49	48	46	36	25	52
302 LN	53	51	50	49	47	37	26	53
352 LN	55	53	52	51	49	39	28	55
402 LN	55	53	52	51	49	39	28	55
502 LN	55	53	52	51	49	39	28	55
552 LN	55	53	52	51	49	39	28	55
602 LN	55	53	52	51	49	39	28	55

CLH ELN sizes	Frequencies (Hz)							Lw global dB(A)
	125	250	500	1000	2000	4000	8000	
182 ELN	78	76	75	74	72	62	51	78
202 ELN	78	76	75	74	72	62	51	78
242 ELN	79	77	76	75	73	63	52	79
302 ELN	80	78	77	76	74	64	53	80
352 ELN	82	80	79	78	76	66	55	82
402 ELN	83	81	80	79	77	67	56	83
502 ELN	83	81	80	79	77	67	56	83
552 ELN	83	81	80	79	77	67	56	83
602 ELN	83	81	80	79	77	67	56	83

CLH ELN sizes	Frequencies (Hz)							Lp* global dB(A)
	125	250	500	1000	2000	4000	8000	
182 ELN	46	44	43	42	40	30	19	46
202 ELN	46	44	43	42	40	30	19	46
242 ELN	47	45	44	43	41	31	20	47
302 ELN	48	46	45	44	42	32	21	48
352 ELN	50	48	47	46	44	34	23	50
402 ELN	51	49	48	47	45	35	24	51
502 ELN	51	49	48	47	45	35	24	51
552 ELN	51	49	48	47	45	35	24	51
602 ELN	51	49	48	47	45	35	24	51

CLH HPF sizes	Frequencies (Hz)							Lw global dB(A)
	125	250	500	1000	2000	4000	8000	
182 HPF	89	87	86	85	83	73	62	89
202 HPF	89	87	86	85	83	73	62	89
242 HPF	90	88	87	86	84	74	63	90
302 HPF	90	88	87	86	84	74	63	90
352 HPF	92	90	89	88	86	76	65	92
402 HPF	92	90	89	88	86	76	65	94
502 HPF	93	91	90	89	87	77	66	94
552 HPF	92	90	89	88	86	76	65	94
602 HPF	93	91	90	89	87	77	66	94

CLH HPF sizes	Frequencies (Hz)							Lp* global dB(A)
	125	250	500	1000	2000	4000	8000	
182 HPF	57	55	54	53	51	41	30	57
202 HPF	57	55	54	53	51	41	30	57
242 HPF	58	56	55	54	52	42	31	58
302 HPF	58	56	55	54	52	42	31	58
352 HPF	60	58	57	56	54	44	33	60
402 HPF	60	58	57	56	54	44	33	62
502 HPF	61	59	58	57	55	45	34	62
552 HPF	61	59	58	57	55	45	34	62
602 HPF	61	59	58	57	55	45	34	62

CLH SIF sizes	Frequencies (Hz)							Lw global dB(A)
	125	250	500	1000	2000	4000	8000	
352 SIF	92.5	90.5	89.5	88.5	86.5	76.5	65.5	92.5
402 SIF	94	92	91	90	88	78	67	94
502 SIF	94	92	91	90	88	78	67	94
552 SIF	95	93	92	91	89	79	68	95
602 SIF	95	93	92	91	89	79	68	95

CLH SIF sizes	Frequencies (Hz)							Lp* global dB(A)
	125	250	500	1000	2000	4000	8000	
352 SIF	60.5	58.5	57.5	56.5	54.5	44.5	33.5	60.5
402 SIF	62	60	59	58	56	46	35	62
502 SIF	62	60	59	58	56	46	35	62
552 SIF	63	61	60	59	57	47	36	63
602 SIF	63	61	60	59	57	47	36	63

* Sound pressure levels are given for a distance of 10 meters, according to ISO 3744. Directivity factor Q=2. Tolerance = 2 dB.

Cooling Capacities - CLH/CLH EH 182 ÷ 602 STD/LN/HPF/SIF*

CLH Models	LWT (°C)	Ambient air temperature (°C)													
		25		30		32		35		40		43		46	
		Cool. Cap. (kW)	Power Input (kW)	Cool. Cap. (kW)	Power Input (kW)	Cool. Cap. (kW)	Power Input (kW)	Cool. Cap. (kW)	Power Input (kW)	Cool. Cap. (kW)	Power Input (kW)	Cool. Cap. (kW)	Power Input (kW)	Cool. Cap. (kW)	Power Input (kW)
182	6	44.9	11.3	42.1	11.8	41.0	12.0	39.4	12.2	36.7	12.7	33.5	13.1	25.9	15.1
	7	46.4	11.5	43.6	12.0	42.5	12.2	40.8	12.5	37.9	12.9	34.5	13.5	26.9	15.2
	8	48.0	11.8	45.0	12.3	43.9	12.5	42.2	12.8	39.3	13.2	35.8	13.7		
	10	51.2	12.2	48.2	12.8	47.0	13.0	45.1	13.3	42.1	13.8	38.6	14.4		
	12	54.6	12.7	51.4	13.3	50.0	13.5	48.1	13.8	44.9	14.4				
	15	59.9	13.5	56.4	14.1	54.9	14.3	52.8	14.7	49.4	15.4				
202	6	56.6	14.8	54.7	16.2	54.0	16.6	52.7	17.3	48.4	19.3	45.5	20.4	44.6	21.1
	7	58.9	15.0	56.9	16.3	56.2	16.8	54.8	17.5	50.4	19.5	47.3	20.6	46.4	21.3
	8	60.0	15.1	58.0	16.5	57.3	17.0	55.8	17.7	51.3	19.8	50.4	20.8		
	10	62.2	15.6	60.2	17.4	59.4	17.4	57.9	18.1	53.2	20.3	52.4	21.3		
	12	64.3	16.0	62.2	17.4	61.4	17.9	59.9	18.7	55.1	20.7				
	15	67.3	16.6	65.0	18.1	64.4	18.6	62.7	19.3	57.8	21.5				
242	6	74.0	22.3	69.5	23.2	67.7	23.6	64.9	24.1	60.5	24.9	57.9	25.4	55.2	25.9
	7	76.6	22.7	71.9	23.7	70.1	24.1	67.3	24.6	62.6	25.5	59.8	26.0	56.9	26.5
	8	79.1	23.2	74.3	24.2	72.5	24.6	69.5	25.1	64.8	26.0	62.0	26.6		
	10	84.5	24.1	79.4	25.2	77.5	25.6	74.4	26.2	69.5	27.1	66.6	27.7		
	12	90.1	25.0	84.8	26.2	82.5	26.6	79.3	27.3	74.1	28.3				
	15	98.7	26.5	93.0	27.7	90.6	28.2	87.1	29.0	81.4	30.3				
302	6	86.4	25.3	81.1	26.4	79.1	26.8	75.8	27.4	70.6	28.4	67.6	28.9	64.5	29.4
	7	89.4	25.9	84.0	27.0	81.9	27.4	78.6	28.0	73.1	29.0	69.8	29.6	66.5	30.2
	8	92.4	26.4	86.8	27.5	84.6	28.0	81.2	28.6	75.7	29.6	72.4	30.2		
	10	98.7	27.4	92.8	28.6	90.5	29.1	86.9	29.8	81.1	30.9	77.7	31.6		
	12	105.2	28.5	99.0	29.8	96.4	30.3	92.7	31.0	86.5	32.2				
	15	115.3	30.1	108.6	31.6	105.8	32.1	101.8	33.0	95.1	34.5				
352	6	96.7	30.4	90.7	31.7	88.4	32.2	84.8	32.9	79.0	34.0	75.6	34.7	72.1	35.3
	7	100.0	31.0	93.9	32.4	91.6	32.9	87.9	33.6	81.8	34.8	78.1	35.5	74.4	36.2
	8	103.3	31.7	97.0	33.0	94.6	33.6	90.8	34.3	84.7	35.5	81.0	36.2		
	10	110.4	32.9	103.8	34.4	101.2	34.9	97.2	35.7	90.7	37.0	86.9	37.9		
	12	117.7	34.2	110.7	35.7	107.8	36.3	103.6	37.2	96.8	38.7				
	15	128.9	36.2	121.5	37.9	118.3	38.6	113.8	39.6	106.4	41.4				
402	6	108.5	31.7	101.9	33.0	99.3	33.5	95.2	34.3	88.7	35.4	84.9	36.1	81.0	36.8
	7	112.3	32.3	105.5	33.7	102.8	34.2	98.7	35.0	91.8	36.2	87.7	37.0	83.5	37.7
	8	116.0	33.0	109.0	34.4	106.3	34.9	102.0	35.7	95.1	37.0	90.9	37.8		
	10	123.9	34.3	116.5	35.8	113.6	36.4	109.1	37.2	101.9	38.6	97.6	39.5		
	12	132.1	35.6	124.3	37.2	121.0	37.9	116.4	38.8	108.6	40.3				
	15	144.8	37.7	136.4	39.5	132.9	40.2	127.8	41.3	119.4	43.1				
502	6	121.4	38.0	113.9	39.6	111.0	40.2	106.5	41.1	99.2	42.5	94.9	43.3		
	7	125.6	38.8	118.0	40.5	115.0	41.1	110.4	42.0	102.7	43.5	98.1	44.4		
	8	129.8	39.6	121.9	41.3	118.8	41.9	114.1	42.9	106.4	44.4	101.7	45.3		
	10	138.6	41.1	130.3	43.0	127.1	43.7	122.1	44.7	113.9	46.3				
	12	147.8	42.7	139.0	44.7	135.4	45.4	130.1	46.5	121.5	48.3				
	15	162.0	45.2	152.5	47.3	148.6	48.2	143.0	49.5	133.6	51.7				
552	6	132.9	44.7	124.8	46.6	121.6	47.3	116.7	48.4	108.7	50.0	99.2	51.9		
	7	137.6	45.6	129.2	47.6	125.9	48.3	120.9	49.4	112.4	51.1	102.3	53.2		
	8	142.1	46.5	133.5	48.6	130.2	49.3	124.9	50.4	116.5	52.2	106.2	54.3		
	10	151.8	48.4	142.7	50.5	139.2	51.4	133.7	52.5	124.8	54.4				
	12	161.8	50.3	152.3	52.5	148.3	53.4	142.5	54.7	133.1	56.8				
	15	177.4	53.2	167.1	55.7	162.8	56.7	156.6	58.2	146.3	60.8				
602	6	144.5	51.3	135.6	53.5	132.2	54.3	126.8	55.5	118.1	57.4	107.8	59.6		
	7	149.5	52.4	140.4	54.6	136.9	55.5	131.4	56.7	122.2	58.7	111.2	61.1		
	8	154.5	53.4	145.1	55.7	141.5	56.6	135.8	57.9	126.6	59.9	115.4	62.4		
	10	165.0	55.5	155.1	58.0	151.3	58.9	145.3	60.3	135.6	62.5				
	12	175.9	57.7	165.5	60.3	161.1	61.3	154.9	62.8	144.6	65.2				
	15	192.8	61.0	181.6	63.9	176.9	65.1	170.2	66.8	159.0	69.8				

Notes : - LWT : Leaving water temperature.
 - Power input data are given for compressors only.
 * SIF version for sizes 352 to 602 only.

Heating Capacities - CLH/CLH EH 182 ÷ 602 STD/LN/HPF/SIF*

CLH Models	LWT (°C)	Ambient air temperature (°C)													
		-5		-3		0		5		7		10		15	
		Heat. Cap. (kW)	Power Input (kW)	Heat. Cap. (kW)	Power Input (kW)	Heat. Cap. (kW)	Power Input (kW)	Heat. Cap. (kW)	Power Input (kW)	Heat. Cap. (kW)	Power Input (kW)	Heat. Cap. (kW)	Power Input (kW)	Heat. Cap. (kW)	Power Input (kW)
182	30	33.8	7.9	36.5	8.2	40.7	8.7	47.9	9.4	51.0	9.6	55.9	10.0	64.9	10.7
	35	32.4	8.1	35.0	8.5	39.1	9.0	46.3	9.8	49.4	10.1	54.2	10.5	63.1	11.3
	40	30.8	8.4	33.4	8.7	37.5	9.3	44.5	10.1	47.6	10.5	52.4	11.0	61.2	11.9
	45	29.2	8.6	31.7	9.0	35.7	9.6	42.6	10.5	45.7	10.9	50.5	11.5	59.2	12.5
	50					33.8	9.8	40.7	10.9	43.7	11.3	48.5	12.0	57.1	13.1
202	30	43.0	12.5	46.3	12.9	51.7	13.7	60.8	14.8	64.7	15.2	71.0	15.8	82.4	16.9
	35	41.1	12.8	44.4	13.4	49.7	14.2	58.7	15.4	62.6	15.9	68.8	16.6	80.1	17.8
	40	39.1	13.2	42.3	13.8	47.5	14.6	56.5	16.0	60.4	16.6	66.5	17.4	77.7	18.7
	45	37.0	13.5	40.2	14.1	45.3	15.1	54.1	16.6	58.0	17.2	64.1	18.1	75.1	19.7
	50					42.9	15.5	51.6	17.2	55.4	17.9	61.5	18.9	72.4	20.6
242	30	57.3	18.2	61.8	18.9	69.0	19.9	81.1	21.5	86.4	22.1	94.7	23.1	109.9	24.6
	35	54.8	18.7	59.2	19.5	66.3	20.6	78.4	22.4	83.6	23.1	91.9	24.2	106.9	25.9
	40	52.2	19.2	56.5	20.1	63.4	21.3	75.4	23.3	80.6	24.1	88.8	25.3	103.7	27.3
	45	49.4	19.7	53.6	20.6	60.4	22.0	72.2	24.2	77.4	25.1	85.5	26.4	100.3	28.7
	50					57.3	22.6	68.9	25.1	74.0	26.0	82.1	27.5	96.6	30.0
302	30	67.0	21.0	72.2	21.8	80.5	23.0	94.8	24.8	100.9	25.6	110.6	26.6	128.4	28.4
	35	64.0	21.6	69.2	22.5	77.4	23.9	91.5	25.9	97.6	26.7	107.3	27.9	124.9	30.0
	40	60.9	22.2	66.0	23.2	74.1	24.7	88.0	27.0	94.1	27.9	103.7	29.3	121.1	31.5
	45	57.7	22.7	62.6	23.8	70.6	25.4	84.4	28.0	90.4	29.0	99.9	30.5	117.1	33.1
	50					66.9	26.1	80.4	28.9	86.4	30.1	95.8	31.8	112.9	34.7
352	30	74.8	22.9	80.7	23.8	90.0	25.1	105.9	27.1	112.7	27.9	123.6	29.0	143.4	31.0
	35	71.5	23.6	77.3	24.5	86.5	26.0	102.2	28.2	109.1	29.1	119.9	30.5	139.5	32.7
	40	68.1	24.2	73.7	25.3	82.8	26.9	98.4	29.4	105.2	30.4	115.9	31.9	135.3	34.4
	45	64.5	24.8	70.0	25.9	78.8	27.7	94.2	30.5	101.0	31.6	111.6	33.3	130.8	36.1
	50					74.7	28.5	89.9	31.5	96.6	32.8	107.1	34.7	126.1	37.8
402	30	84.1	25.5	90.6	26.5	101.1	28.0	119.0	30.2	126.7	31.1	138.9	32.4	161.2	34.6
	35	80.4	26.3	86.9	27.4	97.2	29.0	114.9	31.5	122.6	32.5	134.7	34.0	156.8	36.5
	40	76.5	27.0	82.9	28.2	93.0	30.0	110.5	32.8	118.2	33.9	130.2	35.6	152.0	38.4
	45	72.5	27.7	78.6	29.0	88.6	30.9	105.9	34.0	113.5	35.3	125.4	37.2	147.0	40.3
	50					84.0	31.8	101.0	35.2	108.5	36.6	120.3	38.7	141.7	42.2
502	30	94.1	29.9	101.4	31.0	113.1	32.8	133.1	35.4	141.8	36.4	155.4	37.9	180.4	40.5
	35	90.0	30.8	97.2	32.1	108.8	34.0	128.6	36.9	137.2	38.1	150.7	39.8	175.4	42.7
	40	85.6	31.6	92.7	33.0	104.1	35.1	123.7	38.4	132.3	39.7	145.7	41.7	170.1	44.9
	45	81.1	32.4	88.0	33.9	99.1	36.2	118.5	39.8	127.0	41.3	140.4	43.5	164.5	47.1
	50					93.9	37.2	113.0	41.2	121.4	42.9	134.6	45.3	158.6	49.4
552	30	103.5	34.4	111.6	35.7	124.5	37.7	146.4	40.7	155.9	41.9	171.0	43.6	198.4	46.5
	35	99.0	35.4	106.9	36.9	119.6	39.1	141.4	42.4	150.9	43.8	165.8	45.8	193.0	49.1
	40	94.2	36.4	102.0	38.0	114.5	40.4	136.1	44.1	145.5	45.7	160.3	47.9	187.1	51.6
	45	89.2	37.3	96.8	39.0	109.0	41.6	130.4	45.8	139.7	47.5	154.4	50.0	181.0	54.2
	50					103.3	42.8	124.3	47.4	133.6	49.3	148.1	52.1	174.4	56.8
602	30	112.9	38.8	121.7	40.3	135.8	42.5	159.8	45.9	170.1	47.2	186.5	49.2	216.5	52.5
	35	107.9	40.0	116.6	41.6	130.5	44.1	154.3	47.9	164.6	49.4	180.9	51.7	210.5	55.4
	40	102.7	41.1	111.3	42.9	124.9	45.6	148.4	49.8	158.7	51.5	174.8	54.1	204.2	58.3
	45	97.3	42.0	105.6	44.0	119.0	47.0	142.2	51.7	152.4	53.6	168.4	56.4	197.4	61.2
	50					112.7	48.3	135.6	53.5	145.7	55.6	161.6	58.8	190.3	64.1

Notes : - LWT : Leaving water temperature.
 - Power input data are given for compressors only.
 * SIF version for sizes 352 to 602 only.

Cooling Capacities - CLH/CLH EH 182 ÷ 602 ELN

CLH models	LWT (°C)	Ambient air temperature (°C)									
		25		30		32		35		40	
		Cool. Cap. (kW)	Power Input (kW)	Cool. Cap. (kW)	Power Input (kW)	Cool. Cap. (kW)	Power Input (kW)	Cool. Cap. (kW)	Power Input (kW)	Cool. Cap. (kW)	Power Input (kW)
182 ELN	6	42.2	10.4	40.8	11.4	40.3	11.7	39.2	12.2	36.1	13.6
	7	43.9	10.6	42.4	11.5	41.9	11.9	40.8	12.3	37.5	13.8
	8	44.7	10.7	43.2	11.7	42.7	12.0	41.6	12.5		
	10	46.4	11.0	44.8	31.5	44.3	12.3	43.1	12.8		
	12	47.9	11.3	46.3	12.3	45.7	12.6	44.6	13.2		
	15	50.2	11.7	48.5	12.8	48.0	13.1	46.7	13.6		
202 ELN	6	55.9	15.4	54.1	16.8	53.4	17.3	52.0	18.0	47.8	20.1
	7	58.2	15.6	56.2	17.0	55.5	17.5	54.1	18.2	49.8	20.3
	8	59.3	15.8	57.3	17.2	56.6	17.7	55.1	18.5		
	10	61.5	16.2	59.4	46.5	58.7	18.1	57.2	18.9		
	12	63.5	16.6	61.4	18.1	60.6	18.6	59.2	19.4		
	15	66.5	17.3	64.3	18.9	63.6	19.3	61.9	20.1		
242 ELN	6	70.9	23.4	66.6	24.4	64.9	24.8	62.2	25.4	58.0	26.2
	7	73.4	23.9	68.9	24.9	67.2	25.3	64.5	25.9	60.0	26.8
	8	75.8	24.4	71.2	25.5	69.4	25.9	66.7	26.4		
	10	81.0	25.4	76.1	26.5	74.2	26.9	71.3	27.6		
	12	86.3	26.4	81.2	27.5	79.1	28.0	76.0	28.7		
	15	94.6	27.9	89.1	29.2	86.8	29.7	83.5	30.5		
302 ELN	6	78.5	28.8	73.7	30.0	71.8	30.5	68.9	31.2	64.2	32.2
	7	81.3	29.4	76.3	30.6	74.4	31.1	71.4	31.8	66.4	32.9
	8	83.9	30.0	78.8	31.3	76.9	31.8	73.8	32.5		
	10	89.7	31.1	84.3	32.5	82.2	33.1	79.0	33.8		
	12	95.6	32.4	89.9	33.8	87.6	34.4	84.2	35.2		
	15	104.7	34.2	98.7	35.8	96.1	36.5	92.5	37.5		
352 ELN	6	95.7	30.7	89.8	32.0	87.5	32.5	83.9	33.2	78.2	34.3
	7	99.0	31.3	93.0	32.7	90.6	33.2	87.0	33.9	80.9	35.1
	8	102.3	31.9	96.0	33.3	93.7	33.9	89.9	34.6		
	10	109.3	33.2	102.7	34.7	100.1	35.2	96.2	36.1		
	12	116.4	34.5	109.6	36.1	106.7	36.7	102.6	37.6		
	15	127.6	36.5	120.2	38.2	117.1	38.9	112.7	40.0		
402 ELN	6	102.3	35.7	96.0	37.2	93.5	37.8	89.7	38.6	83.6	39.9
	7	105.8	36.4	99.4	37.9	96.9	38.5	93.0	39.4	86.5	40.8
	8	109.3	37.1	102.7	38.7	100.1	39.3	96.1	40.2		
	10	116.8	38.6	109.8	40.3	107.1	41.0	102.8	41.9		
	12	124.5	40.1	117.1	41.9	114.1	42.6	109.6	43.6		
	15	136.4	42.4	128.5	44.4	125.2	45.2	120.4	46.4		
502 ELN	6	114.6	42.5	107.5	44.4	104.8	45.0	100.5	46.0	93.7	47.6
	7	118.6	43.4	111.4	45.3	108.5	46.0	104.2	47.0	96.9	48.6
	8	122.5	44.3	115.0	46.2	112.2	46.9	107.7	48.0		
	10	130.9	46.0	123.0	48.1	119.9	48.9	115.2	50.0		
	12	139.5	47.8	131.2	50.0	127.8	50.8	122.8	52.1		
	15	152.9	50.6	144.0	53.0	140.3	54.0	134.9	55.4		
552 ELN	6	132.9	44.7	124.8	46.6	121.6	47.3	116.7	48.4	108.7	50.0
	7	137.6	45.6	129.2	47.6	125.9	48.3	120.9	49.4	112.4	51.1
	8	142.1	46.5	133.5	48.6	130.2	49.3	124.9	50.4		
	10	151.8	48.4	142.7	50.5	139.2	51.4	133.7	52.5		
	12	161.8	50.3	152.3	52.5	148.3	53.4	142.5	54.7		
	15	177.4	53.2	167.1	55.7	162.8	56.7	156.6	58.2		
602 ELN	6	144.5	51.3	135.6	53.5	132.2	54.3	126.8	55.5	118.1	57.4
	7	149.5	52.4	140.4	54.6	136.9	55.5	131.4	56.7	122.2	58.7
	8	154.5	53.4	145.1	55.7	141.5	56.6	135.8	57.9		
	10	165.0	55.5	155.1	58.0	151.3	58.9	145.3	60.3		
	12	175.9	57.7	165.5	60.3	161.1	61.3	154.9	62.8		
	15	192.8	61.0	181.6	63.9	176.9	65.1	170.2	66.8		

Notes : - LWT : Leaving water temperature.
 - Power input data are given for compressors only.

Heating Capacities - CLH/CLH EH 182 ÷ 602 ELN

CLH Models	LWT (°C)	Ambient air temperature (°C)													
		-5		-3		0		5		7		10		15	
		Heat. Cap. (kW)	Power Input (kW)	Heat. Cap. (kW)	Power Input (kW)	Heat. Cap. (kW)	Power Input (kW)	Heat. Cap. (kW)	Power Input (kW)	Heat. Cap. (kW)	Power Input (kW)	Heat. Cap. (kW)	Power Input (kW)	Heat. Cap. (kW)	Power Input (kW)
182 ELN	30	29.9	9.1	32.3	9.5	36.0	10.0	42.4	10.8	45.1	11.1	49.5	11.6	57.4	12.3
	35	28.6	9.4	30.9	9.8	34.6	10.4	40.9	11.3	43.6	11.6	48.0	12.1	55.8	13.0
	40	27.2	9.7	29.5	10.1	33.1	10.7	39.4	11.7	42.1	12.1	46.4	12.7	54.1	13.7
	45	25.8	9.9	28.0	10.3	31.5	11.0	37.7	12.2	40.4	12.6	44.7	13.3	52.3	14.4
	50					29.9	11.4	36.0	12.6	38.6	13.1	42.8	13.8	50.5	15.1
202 ELN	30	40.6	12.5	43.8	12.9	48.8	13.7	57.5	14.7	61.2	15.2	67.1	15.8	77.9	16.9
	35	38.8	12.8	41.9	13.4	46.9	14.2	55.5	15.4	59.2	15.9	65.1	16.6	75.7	17.8
	40	37.0	13.2	40.0	13.8	44.9	14.6	53.4	16.0	57.1	16.6	62.9	17.4	73.4	18.7
	45	35.0	13.5	38.0	14.1	42.8	15.1	51.1	16.6	54.8	17.2	60.6	18.1	71.0	19.7
	50					40.5	15.5	48.8	17.2	52.4	17.9	58.1	18.9	68.4	20.6
242 ELN	30	55.0	18.1	59.3	18.8	66.1	19.8	77.8	21.4	82.8	22.0	90.8	23.0	105.4	24.5
	35	52.6	18.6	56.8	19.4	63.5	20.6	75.1	22.3	80.1	23.0	88.1	24.1	102.5	25.8
	40	50.0	19.1	54.2	20.0	60.8	21.3	72.3	23.2	77.3	24.0	85.1	25.2	99.4	27.2
	45	47.4	19.6	51.4	20.5	57.9	21.9	69.2	24.1	74.2	25.0	82.0	26.3	96.1	28.5
	50					54.9	22.5	66.0	25.0	70.9	25.9	78.7	27.4	92.6	29.9
302 ELN	30	60.7	20.8	65.5	21.6	73.1	22.8	86.0	24.7	91.5	25.4	100.4	26.5	116.5	28.2
	35	58.1	21.5	62.8	22.4	70.2	23.7	83.0	25.7	88.6	26.5	97.3	27.8	113.3	29.8
	40	55.3	22.1	59.9	23.0	67.2	24.5	79.9	26.8	85.4	27.7	94.1	29.0	109.8	31.3
	45	52.4	22.6	56.8	23.6	64.0	25.2	76.5	27.8	82.0	28.8	90.6	30.3	106.2	32.9
	50					60.7	26.0	73.0	28.7	78.4	29.9	86.9	31.6	102.4	34.4
352 ELN	30	74.1	22.9	79.9	23.8	89.1	25.1	104.8	27.1	111.6	27.9	122.4	29.0	142.0	31.0
	35	70.8	23.6	76.5	24.5	85.6	26.0	101.2	28.2	108.0	29.1	118.7	30.5	138.1	32.7
	40	67.4	24.2	73.0	25.3	82.0	26.9	97.4	29.4	104.1	30.4	114.7	31.9	134.0	34.4
	45	63.8	24.8	69.3	25.9	78.1	27.7	93.3	30.5	100.0	31.6	110.5	33.3	129.5	36.1
	50					74.0	28.5	89.0	31.5	95.6	32.8	106.0	34.7	124.9	37.8
402 ELN	30	78.5	25.5	84.6	26.5	94.4	27.9	111.1	30.1	118.3	31.0	129.7	32.3	150.6	34.5
	35	75.1	26.2	81.1	27.3	90.8	28.9	107.3	31.4	114.5	32.4	125.8	33.9	146.4	36.4
	40	71.5	27.0	77.4	28.1	86.9	29.9	103.2	32.7	110.4	33.8	121.6	35.5	142.0	38.3
	45	67.7	27.6	73.5	28.9	82.7	30.9	98.9	33.9	106.0	35.2	117.2	37.1	137.3	40.2
	50					78.4	31.7	94.3	35.1	101.3	36.5	112.4	38.6	132.4	42.1
502 ELN	30	90.4	29.8	97.4	31.0	108.7	32.7	127.9	35.3	136.2	36.3	149.3	37.8	173.3	40.4
	35	86.4	30.7	93.4	32.0	104.5	33.9	123.5	36.8	131.8	38.0	144.8	39.7	168.5	42.6
	40	82.3	31.6	89.1	32.9	100.0	35.0	118.8	38.3	127.0	39.6	140.0	41.6	163.4	44.8
	45	77.9	32.3	84.5	33.8	95.2	36.1	113.8	39.7	122.0	41.2	134.8	43.4	158.0	47.0
	50					90.2	37.1	108.5	41.1	116.6	42.8	129.3	45.2	152.3	49.3
552 ELN	30	103.5	34.4	111.6	35.7	124.5	37.7	146.4	40.7	155.9	41.9	171.0	43.6	198.4	46.5
	35	99.0	35.4	106.9	36.9	119.6	39.1	141.4	42.4	150.9	43.8	165.8	45.8	193.0	49.1
	40	94.2	36.4	102.0	38.0	114.5	40.4	136.1	44.1	145.5	45.7	160.3	47.9	187.1	51.6
	45	89.2	37.3	96.8	39.0	109.0	41.6	130.4	45.8	139.7	47.5	154.4	50.0	181.0	54.2
	50					103.3	42.8	124.3	47.4	133.6	49.3	148.1	52.1	174.4	56.8
602 ELN	30	112.9	38.8	121.7	40.3	135.8	42.5	159.8	45.9	170.1	47.2	186.5	49.2	216.5	52.5
	35	107.9	40.0	116.6	41.6	130.5	44.1	154.3	47.9	164.6	49.4	180.9	51.7	210.5	55.4
	40	102.7	41.1	111.3	42.9	124.9	45.6	148.4	49.8	158.7	51.5	174.8	54.1	204.2	58.3
	45	97.3	42.0	105.6	44.0	119.0	47.0	142.2	51.7	152.4	53.6	168.4	56.4	197.4	61.2
	50					112.7	48.3	135.6	53.5	145.7	55.6	161.6	58.8	190.3	64.1

Notes : - LWT : Leaving water temperature.
 - Power input data are given for compressors only.

Water Pressure Drop Curves

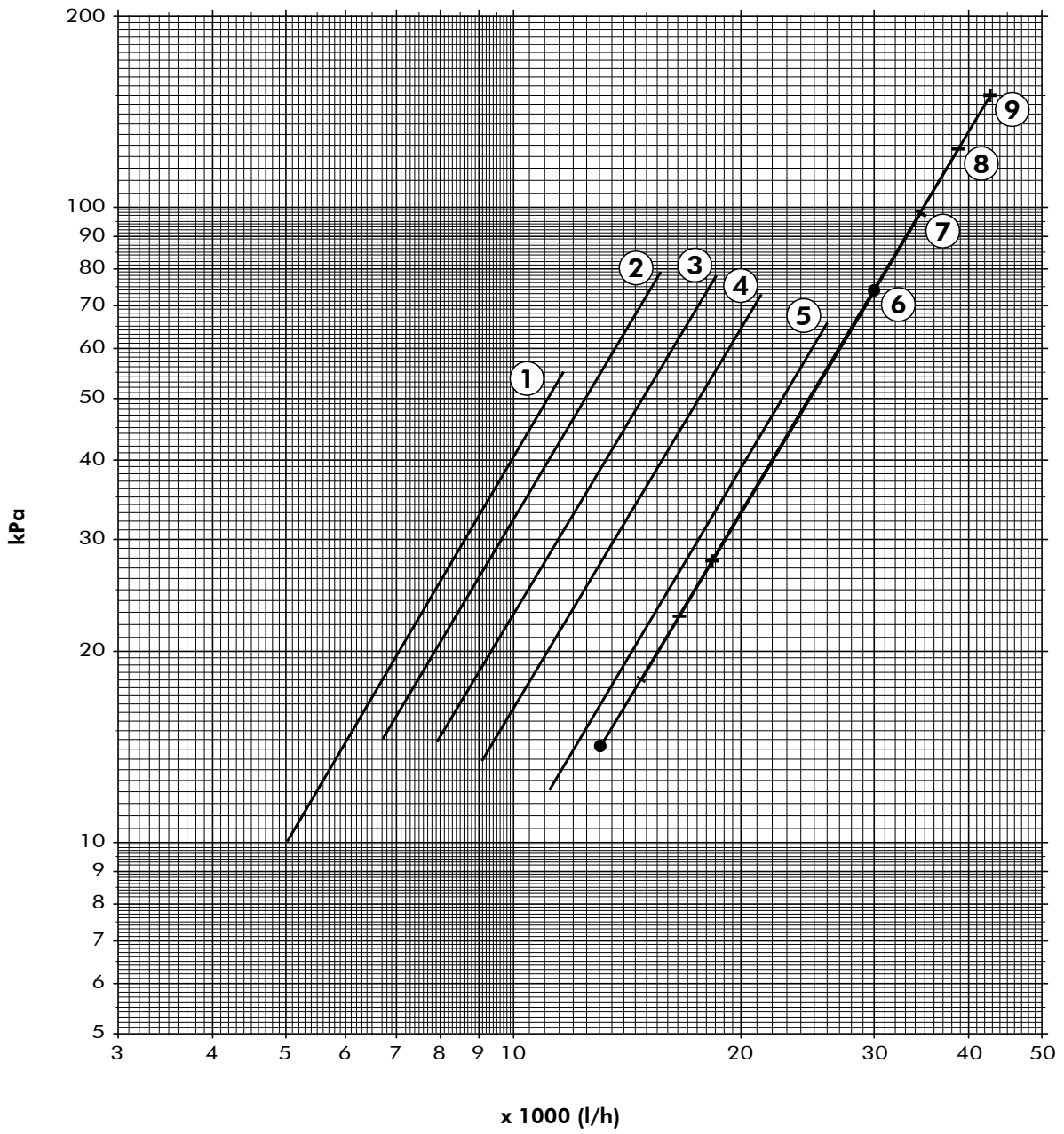

- | | |
|------------|------------|
| ① Size 182 | ⑥ Size 402 |
| ② Size 202 | ⑦ Size 502 |
| ③ Size 242 | ⑧ Size 552 |
| ④ Size 302 | ⑨ Size 602 |
| ⑤ Size 352 | |

Integrated Hydraulic Module Data (optional)

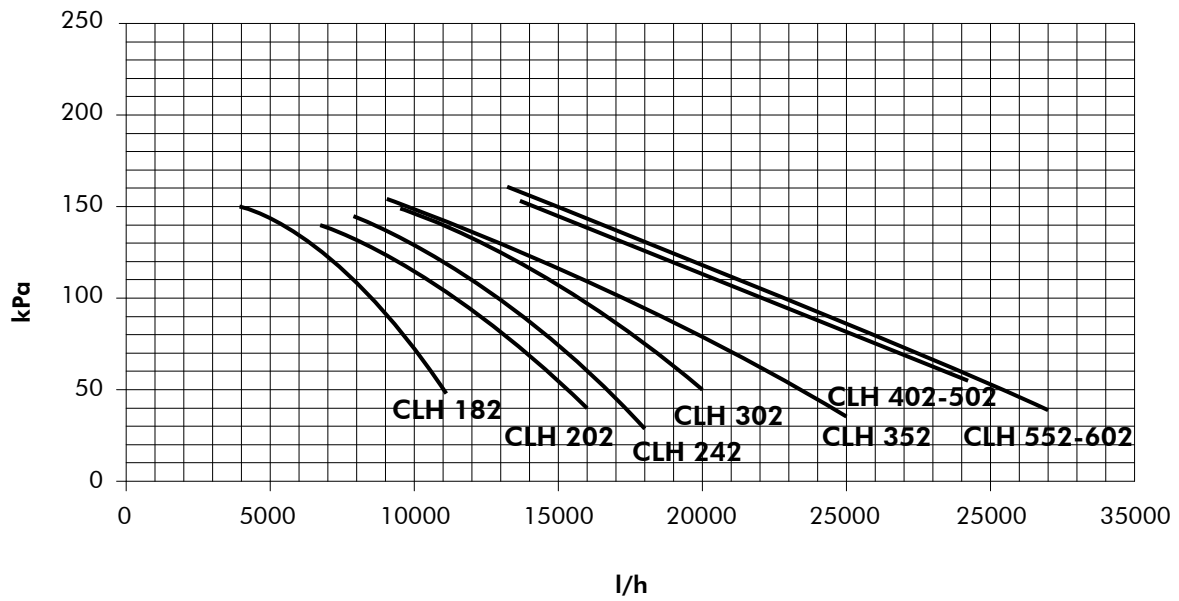

CLH SIZES		182	202	242	302	352	402	502	552	602
Water tank volume - STD/LN/HPF/SIF*	litres	210	210	210	330	400	400	400	400	400
Water tank volume - ELN	litres	210	210	330	330	400	400	400	400	400
Expansion tank volume - STD/LN/HPF/SIF*	litres	12	12	12	18	18	18	18	18	18
Expansion tank volume - ELN	litres	12	12	18	18	18	18	18	18	18
Antifreeze electric heater	kW	0.2	0.2	0.2	0.2	0.2	0.2	0.2	0.2	0.2
Extra electric heating capacity (option 0)	kW	24	24	32	32	32	48	48	48	48
Extra electric heating capacity (option 1)	kW	32	32	48	48	48	56	56	56	56
Extra electric heating capacity (option 2)	kW	48	48	56	56	56	64	64	64	64

* SIF version for sizes 352 to 602 only.

Dimensions

Models CLH 182÷242 STD/LN/HPF - CLH 182 ELN & 202 ELN

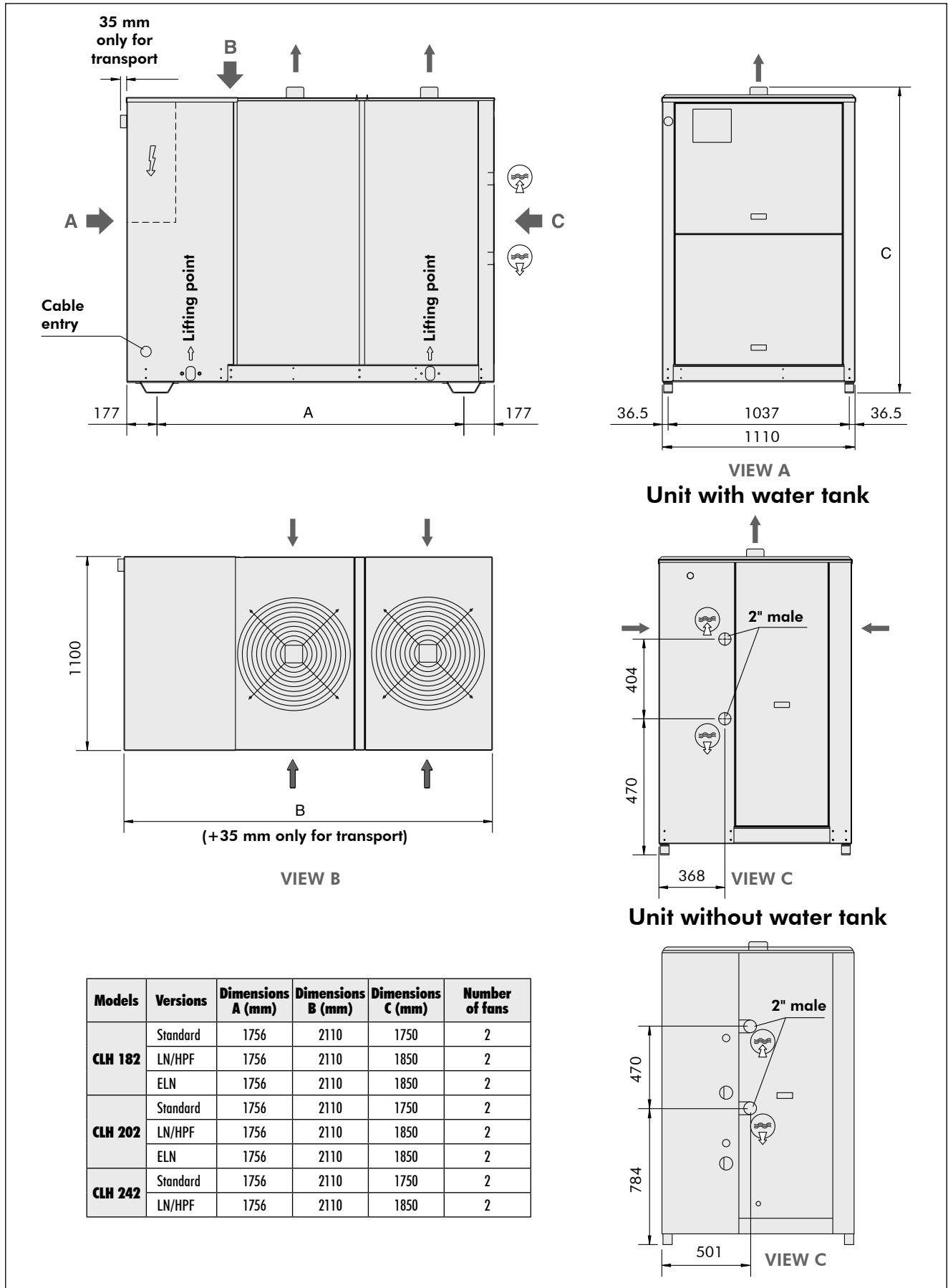

Dimensions (continued)

Models CLH 242 ELN and CLH 302 to 602 STD/LN/ELN/HPF

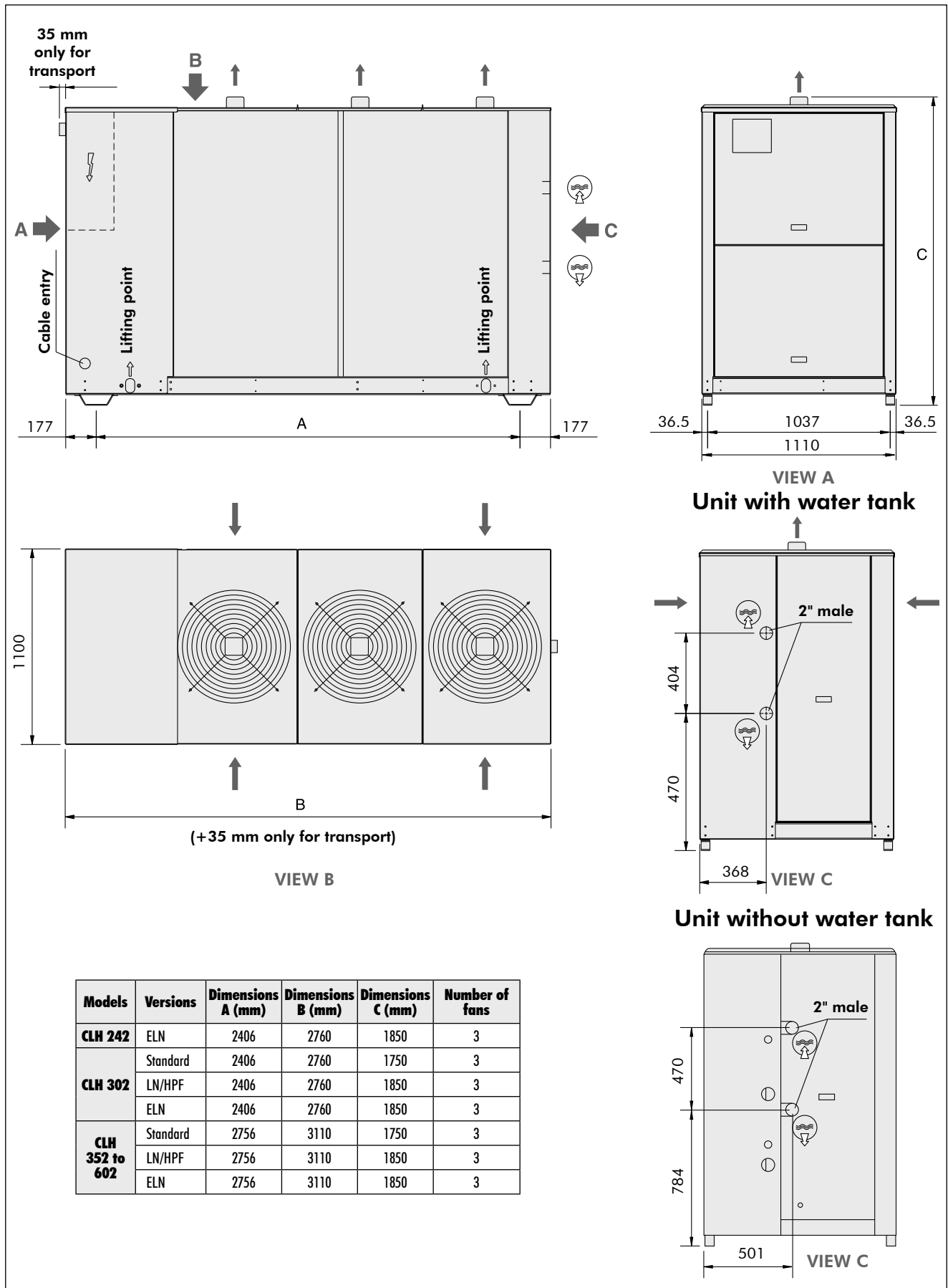

Space Requirements

Single unit applications

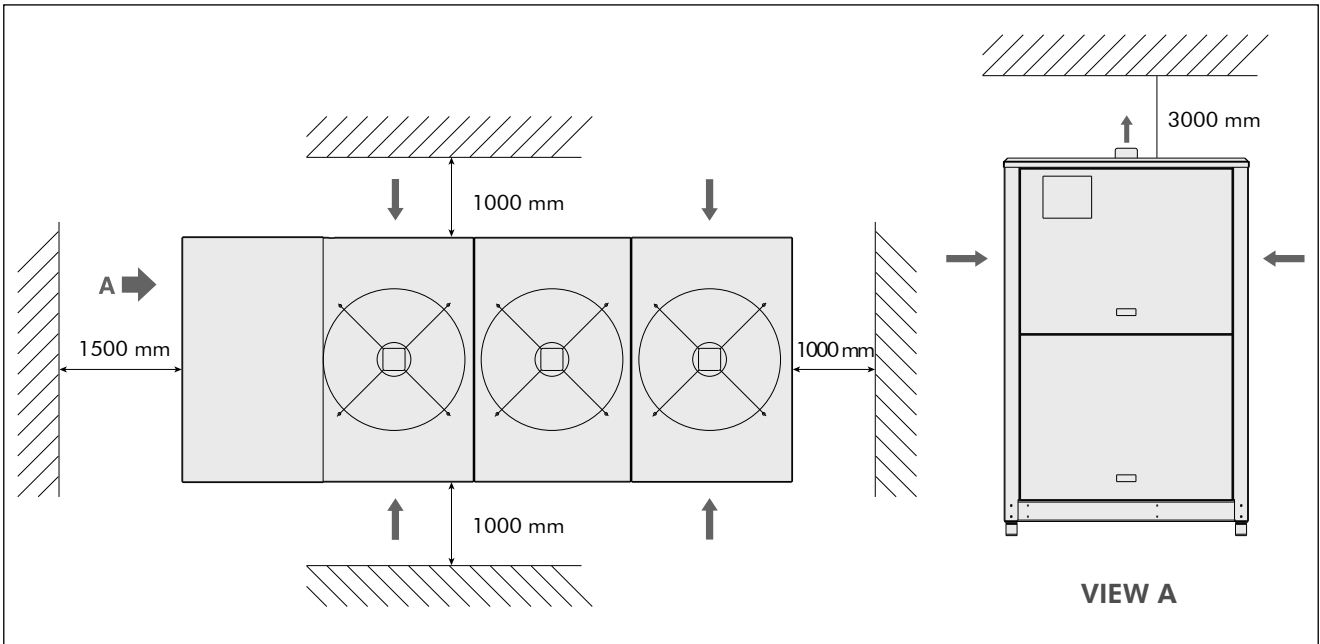

Multi units applications

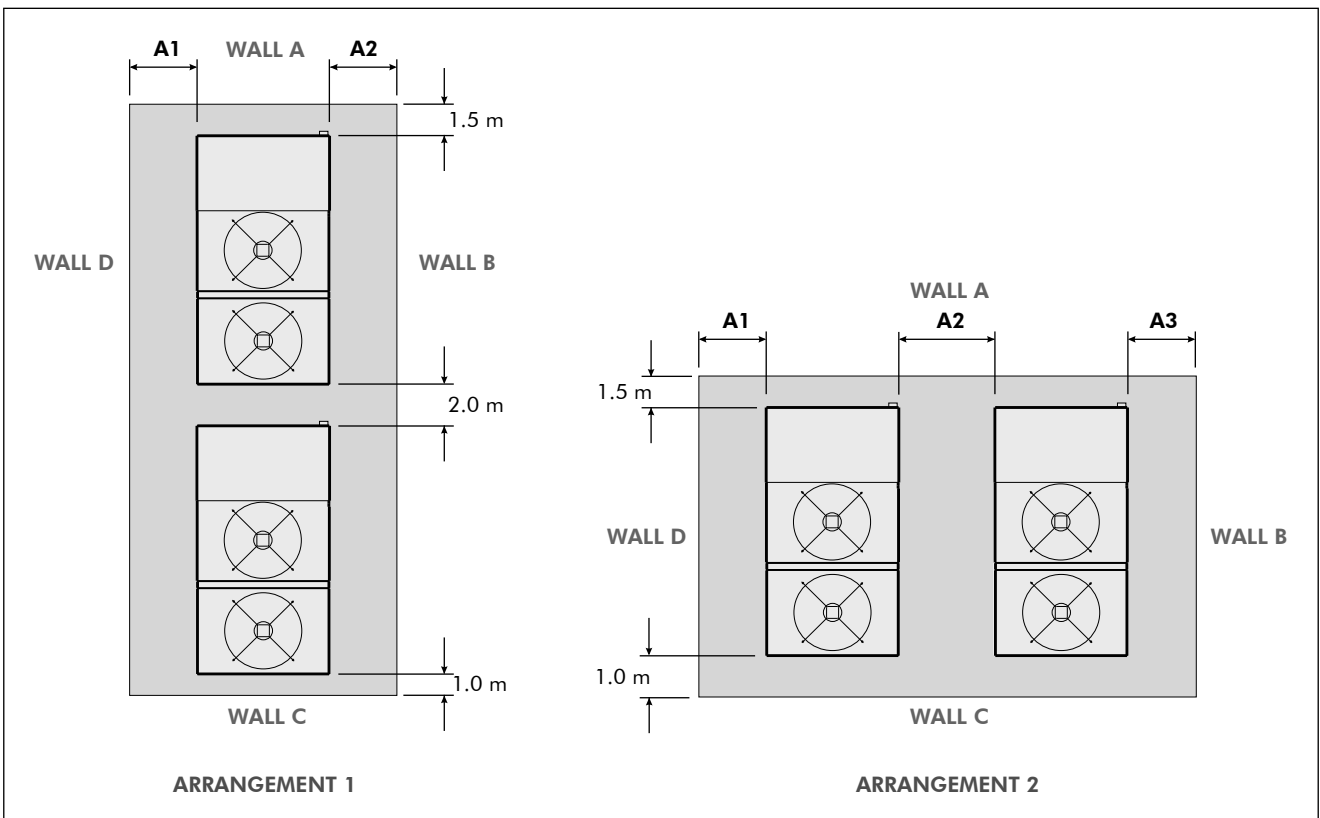

	LOUVRED A & C SOLID B & D			SOLID A & B SOLID C & D			SOLID A & C LOUVRED B & D			LOUVRED A & B SOLID C & D			LOUVRED A & D SOLID B & C		
	A1	A2	A3	A1	A2	A3	A1	A2	A3	A1	A2	A3	A1	A2	A3
ARRANGEMENT 1	1.0	1.0		1.0	1.0		0.8	0.8		1.0	0.8		0.8	1.0	
ARRANGEMENT 2	1.0	1.5	1.0	1.0	2.0	1.0	0.8	2.0	0.8	1.0	1.5	0.8	0.8	1.5	1.0

Note : No more than one wall can be higher than the unit.

The area enclosed by the wall must be kept clear of all obstructions that would impede air flow to the unit.

Notes

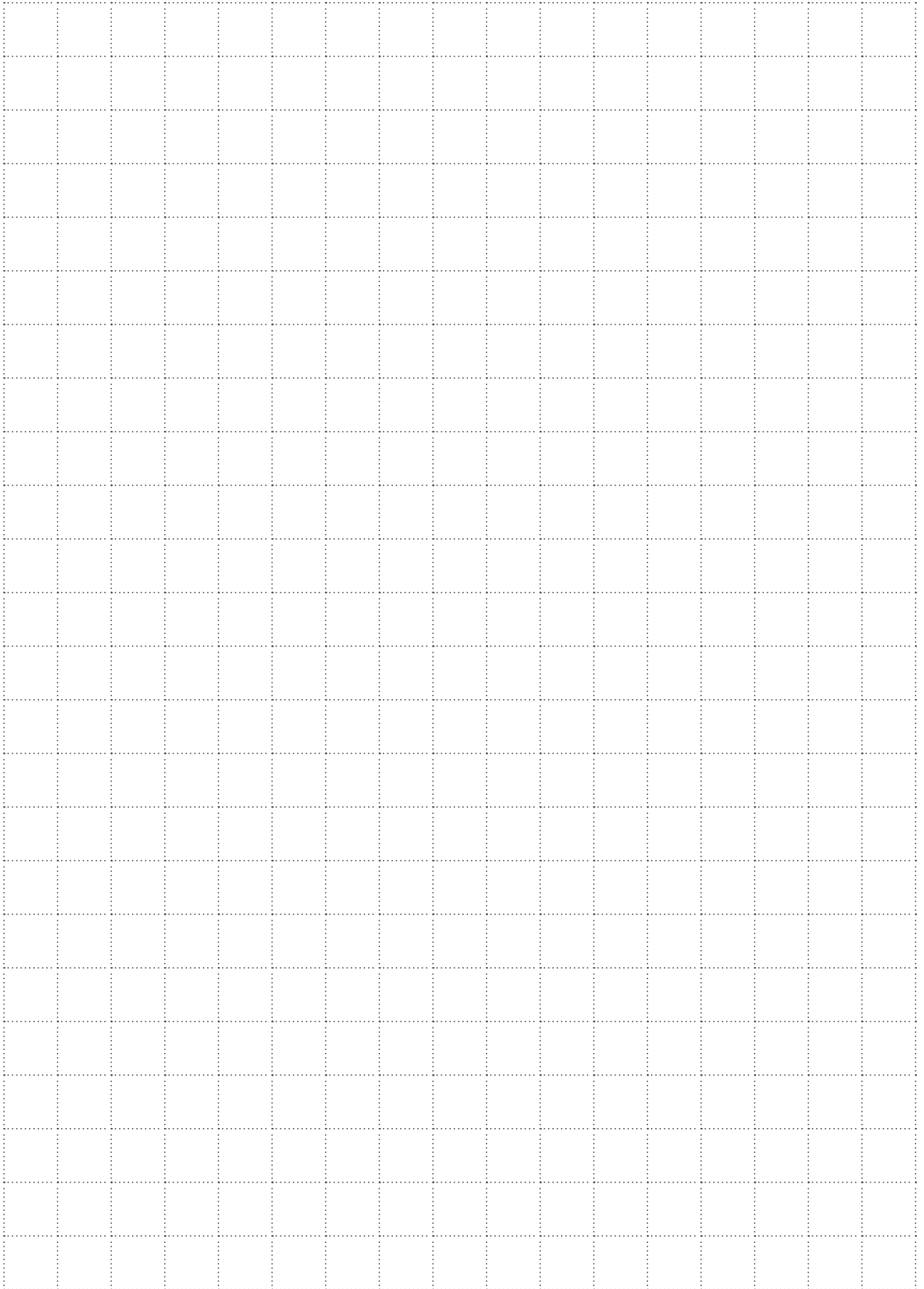

Notes

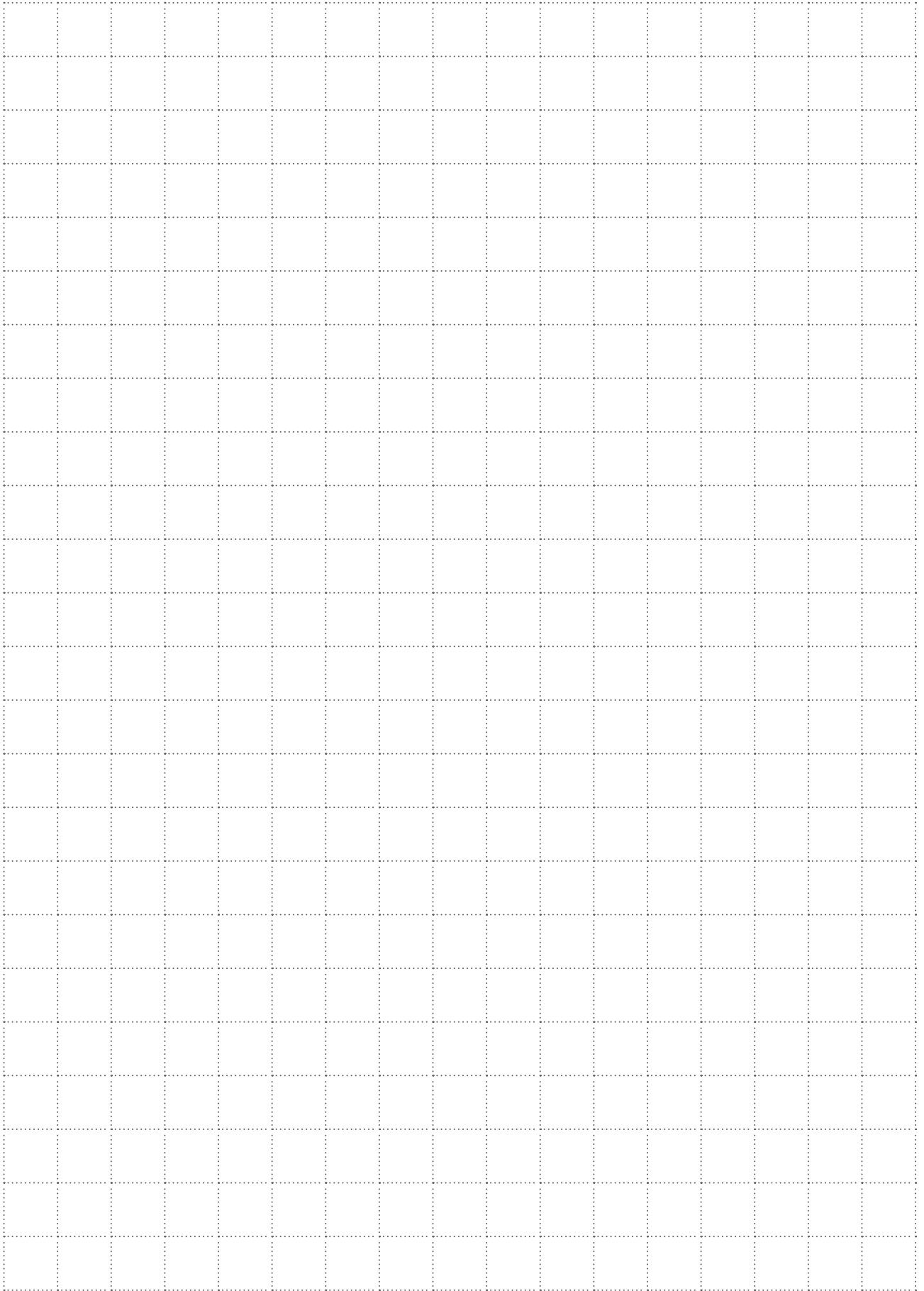

Airwell

As part of our ongoing product improvement programme, our products are subject to change without prior notice. Non contractual photos.



CAC Export Department
42 cours Jean-Jaurès
17800 Pons - France
Tel. : +33 (0)5 46 92 33 33 - Fax : +33 (0)5 46 91 26 44

Your distributor :