

► Air Cooled Condensing Units

CLC 182 to 602



41 to 140 kW



HFC 407C



Technical Brochure

TM CLC-A.2GB

Date : July 2006

Supersedes : TM CLC-A.1GB/10.04

Airwell

Technical Features

General

The CLC air cooled condensing units have been designed to operate with the **HFC 407C** refrigerant.

They are complete with **two independent refrigerant circuits** fitted with a high efficiency and low vibration level Scroll compressor on each circuit.

These units are suitable for outdoor installation on the roof of a building or on the ground.

All the CLC units are completely factory tested in compliance with the internal quality system specifications and procedures, and are ready for field installation.

Thanks to the versions and options available, the CLC air cooled condensing units can fit all the demands of the market.

The CLC range is available in **6 versions**; each version is composed of **9 sizes**.

CLC STD : Standard version fitted with standard equipment intended for reliable operation. The CLC STD units cover a nominal cooling capacity range from 41 to 140 kW.

CLC LN : Low noise version having same equipment as STD version, except that it is fitted with low speed type larger size fans. The CLC LN units cover a nominal cooling capacity range from 41 to 140 kW.

CLC ELN : Extra low noise version fitted with greater heat exchange surface area condenser coils, very low speed type fans and a stepless fan speed controller. Furthermore, the ELN version is equipped with a reinforced soundproofing :

- mufflers mounted on compressor discharge lines (all sizes),
- soundproofing jacket on compressor (sizes 182 to 302),
- sound insulation on compressor compartment (sizes 352 to 602).

The CLC ELN units cover a nominal cooling capacity range from 41 to 140 kW.

CLC HPF : High pressure fan version having same equipment as STD version, except that larger size fans with 80 Pa external static pressure are fitted on this HPF version. The CLC HPF units cover a nominal cooling capacity range from 41 to 140 kW.

CLC SIF : Special inverter fan version having same equipment as STD version but with special axial fan equipped with brushless EC motor, fan speed stepless controlled by discharge pressure sensor fitted on both refrigerant circuits. Fan speed range from 50 to 1150 rpm. Special inverter fans provide nominal external static pressure up to 150 Pa, easily selectable on field by means of software. CLC SIF units are available in 5 sizes (352 to 602) and cover a nominal cooling capacity range from 90 to 140 kW.

CLC HT : High temperature version having same equipment as STD version, except that it is fitted with fans allowing unit to operate at high ambient temperatures (up to +48 °C). The CLC HT units cover a nominal cooling capacity range from 44 to 145 kW.

Reference standards

The following applies to all the sizes and versions belonging to the CLC units :

- ✓ Performance test EN 12055
- ✓ Machine Directive CEE 89 / 392
- ✓ Low Voltage Directive CEE 73/23 (EN 60204-1)
- ✓ Electromagnetic Compatibility Directive CEE 89/336 as modified by Directive CEE 92/31 (EN 50081-1, EN 50082-2)

Cabinet and structure

The unit structure shall be of heavy gauge galvanized steel fastened with non-corrosive screws and bolts. Galvanized steel parts shall be painted with baked on enamel colored white (**RAL 9001**).

Compressors

Each unit shall be equipped with 2 Scroll hermetic compressors.

Compressors on all models shall be mounted on rubber anti-vibration pads and have direct on line starting.

The compressor motors shall be refrigerant gas cooled, with integral thermistor protection against overloads. The overload protection is automatically reset.

The motor terminal boxes shall have IP-54 weather protection.

Condenser coils

The condenser coils shall be seamless copper tubes, arranged in staggered rows, mechanically expanded into corrugated aluminum fins.

Condenser coil fans

The condenser fans shall be direct drive with aluminum aerofoil blades. Each fan will have a painted galvanized steel protection guard.

The totally enclosed fan motors shall have IP 54 degree of protection and thermo-contact protection embedded in their windings.

Fan controls

Each unit can be equipped, as optional , with a stepless fan speed controller, operating on the basis of condensing pressure, to keep fan rpm under control in order to operate at a low ambient temperature (-18 °C).

This fan speed controller is supplied as standard on the ELN units. However, it is not available on HPF and HT units.

Refrigerant circuits

All the units are composed of two independent and separate refrigerant circuits. All the components that constitute each circuit are shown on the functional diagram (see chapter "Refrigerant flow diagram").

Power and control panel

The control compartment shall contain an electronic circuit board and a key control panel with display of operating parameters, alarms and stops.

Thermal relays and fuses are supplied to protect compressors and fans from overloading.

Safety devices

- ✓ Fan thermal protection.
- ✓ Compressor thermal protection.
- ✓ High pressure switch.
- ✓ Low pressure switch.
- ✓ Crankcase heater.

Technical Features (continued)

Factory-installed accessories and options

- ✓ Coils with blue fins covered with a coating easing the flowing of water.
- ✓ Coils with "Silverguard" (polyurethane) coated fins.
- ✓ Coils with copper fins.
- ✓ LP & HP manometers.
- ✓ Condenser coil guards.
- ✓ Compressor overload protection kit.
- ✓ Phase monitor.
- ✓ Stepless fan speed controller (STD and LN versions only).

Field-installed accessories

- ✓ Spring anti-vibration mounts.
- ✓ Remote control kit (On/Off, Heating, Cooling).
- ✓ Modbus interface kit.
- ✓ Remote keyboard panel.
- ✓ Chiller sequencer (4 units maximum).

Control

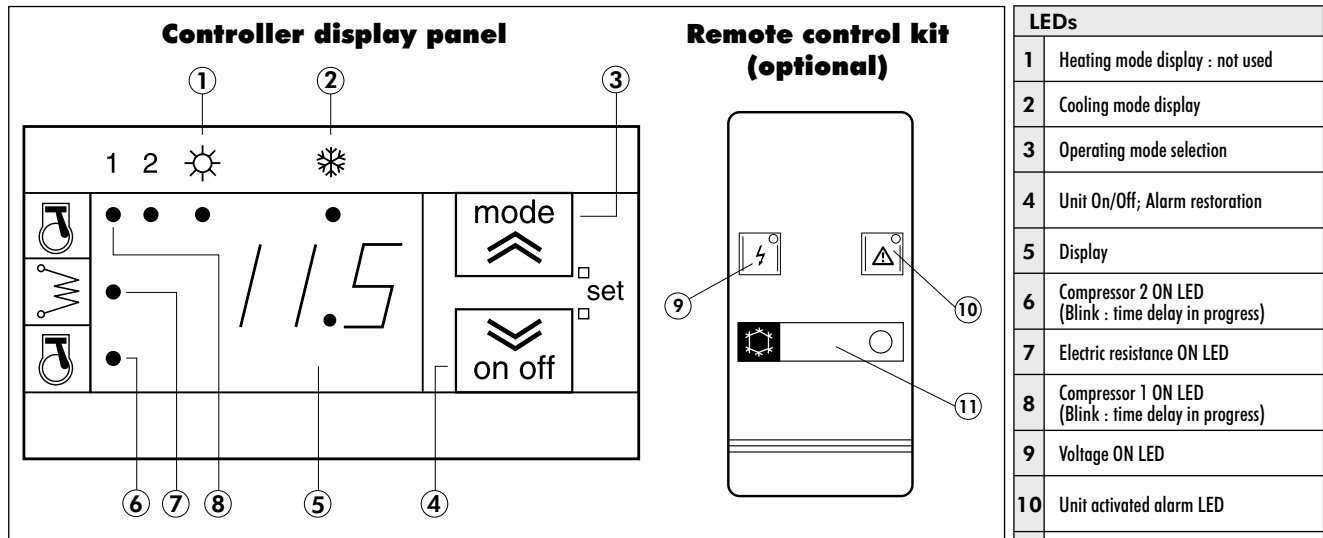

LEDs	
1	Heating mode display : not used
2	Cooling mode display
3	Operating mode selection
4	Unit On/Off; Alarm restoration
5	Display
6	Compressor 2 ON LED (Blink : time delay in progress)
7	Electric resistance ON LED
8	Compressor 1 ON LED (Blink : time delay in progress)
9	Voltage ON LED
10	Unit activated alarm LED
11	Start key and LED - Cooling

The controller provides information on status of operation, configuration and alarms through a display and LEDs on the front panel.

Display

It allows mainly to show :

- the entering water temperature of the unit in tenths of degrees Celsius with a decimal point,
- the alarm code if at least one alarm is active.

If COOLING LED is OFF, the controller is in STANDBY mode.

Refrigerant Flow Diagram

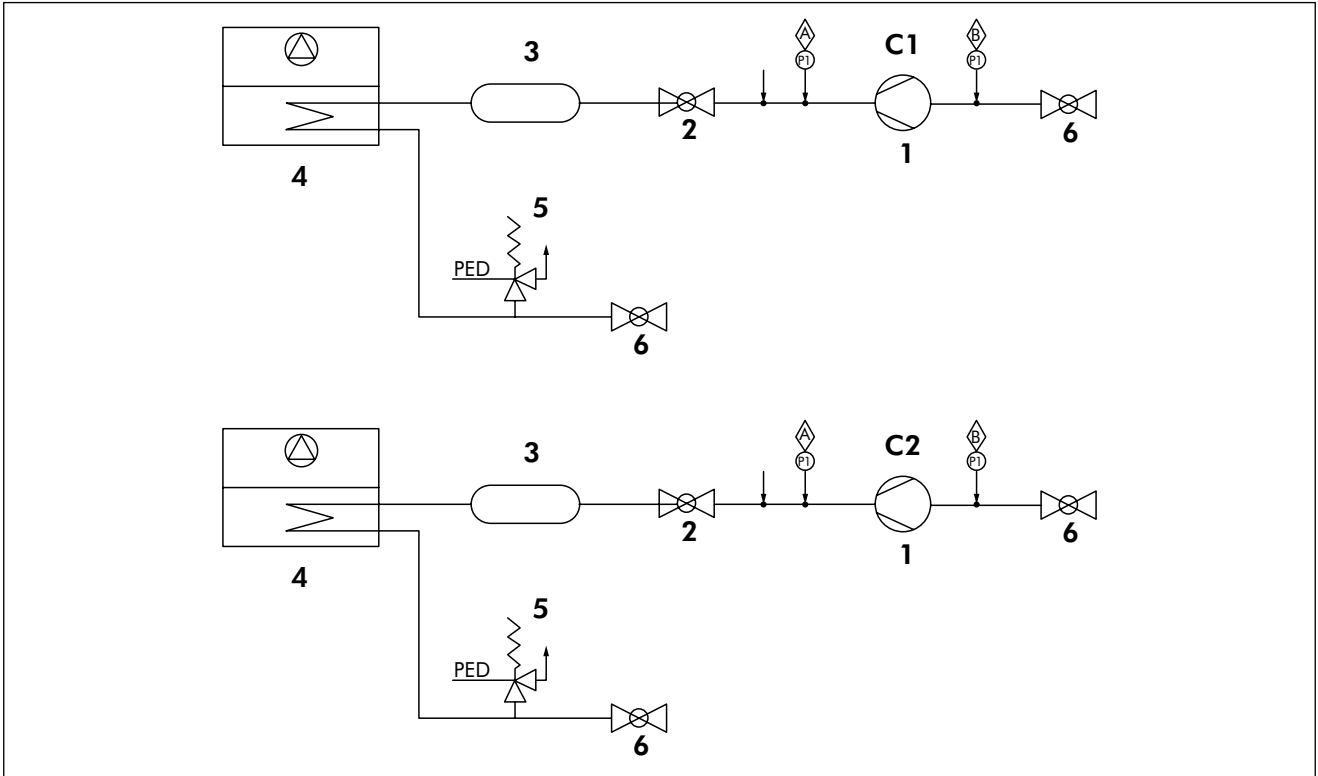

COMPONENTS (refrigerant circuits)	
1	Compressors C1, C2
2	Discharge valve
3	Mufflers (for ELN version only)
4	Air cooled condenser
5	PED pressure relief valve
6	Isolating valves

Safety / Control devices	
	High pressure switch
	Low pressure switch
	Pressure tapping and refrigerant charging/discharging points

Operating Limits

CLC 182 to 302

CLC			182		202		242		302			
			Min.	Max.	Min.	Max.	Min.	Max.	Min.	Max.		
Evaporating temperature			°C								-8 to +13	
Ambient air	Air entering temperature*	Cooling - STD/LN/HPF	°C	15	46	15	46	15	46	15	46	
		Cooling - ELN	°C	-18	46	-18	46	-18	46	-18	46	
		Cooling - HT	°C	15	48	15	48	15	48	15	48	
	External static pressure	Standard fans	Pa	0								
		High pressure fans - HPF version	Pa	80								
Nominal supply voltage			400 V / 3 Ph / 50 Hz									

* Evaporating temperature at 5 °C dew point.

CLC 352 to 602

CLC			352		402		502		552		602		
			Min.	Max.	Min.	Max.	Min.	Max.	Min.	Max.	Min.	Max.	
Evaporating temperature			°C								-8 to +13		
Ambient air	Air entering temperature*	Cooling - STD/LN/HPF	°C	15	46	15	46	15	44	15	44	15	44
		Cooling - ELN	°C	-18	46	-18	46	-18	44	-18	44	-18	44
		Cooling - HT	°C	15	48	15	48	15	46	15	46	15	46
		Cooling - SIF	°C	-18	48	-18	48	-18	48	-18	48	-18	48
	External static pressure	Standard fans	Pa	0									
		High pressure fans - HPF version	Pa	80									
High pressure fans - SIF version		Pa	150										
Nominal supply voltage			400 V / 3 Ph / 50 Hz										

* Evaporating temperature at 5 °C dew point.

Correction Factors

Altitude correction factors

Altitude (m)	Cooling capacity correction factors	Power consumption correction factors
0	1.000	1.000
600	0.987	1.010
1200	0.973	1.020
1800	0.958	1.029
2400	0.943	1.038

Condenser fouling factors

Fouling factor (m ² .°C/kW)	Cooling capacity factor	Power input factor
0.044	1.000	1.000
0.088	0.987	1.023
0.176	0.955	1.068
0.352	0.910	1.135

Physical Data - CLC STD

CLC STD sizes		182	202	242	302	352	402	502	552	602
Nominal cooling capacity (1)	kW	40.9	54.1	64.9	74.3	90.0	105.3	121.4	130.7	140.0
Compressor power input	kW	12.3	18.2	24.2	27.7	33.2	37.5	46.2	52.6	59.0
Maximum power input (2)	kW	18.8	25.4	30.0	35.6	42.5	49.0	59.4	64.7	71.8
EER		3.3	3.0	2.7	2.7	2.7	2.8	2.6	2.5	2.4
Number of refrigerant circuits		2	2	2	2	2	2	2	2	2
Total unit capacity steps	%	50/100	50/100	50/100	50/100	43-57/100	50/100	50/100	43-57/100	50/100
REFRIGERANT										
Type		HFC 407 C								
Charge	kg	Nitrogen								
COMPRESSORS										
Number		2	2	2	2	2	2	2	2	2
Type		Scroll	Scroll	Scroll	Scroll	Scroll	Scroll	Scroll	Scroll	Scroll
AIR COOLED CONDENSERS										
Number		2	2	2	2	2	2	2	2	2
Total coil face area per coil	m ²	2.1	2.1	2.1	2.1	2.85	2.85	3.6	3.6	3.6
Number of rows		2	2	3	4	3	4	4	5	5
FANS										
Number		2	2	2	2	3	3	3	3	3
Total air flow	m ³ /h	21000	21000	20300	19700	30000	28700	30000	26600	26600
Power input	kW	0.96	0.96	0.96	0.96	1.44	1.44	1.44	2.16	2.16
REFRIGERANT CONNECTIONS										
Liquid line	inch	1/2"	1/2"	5/8"	5/8"	5/8"	5/8"	5/8"	5/8"	5/8"
Suction line	inch	7/8"	7/8"	1"5/8"	1"5/8"	1"5/8"	1"5/8"	1"5/8"	1"5/8"	1"5/8"
DIMENSIONS										
Length	mm	2110	2110	2110	2110	2760	2760	3110	3110	3110
Width	mm	1110	1110	1110	1110	1110	1110	1110	1110	1110
Height	mm	1750	1750	1750	1750	1750	1750	1750	1750	1750
WEIGHT										
Shipping	kg	578	603	730	776	841	907	995	1131	1167
SOUND LEVELS										
Sound power levels	dB(A)	84	84	86	86	89	89	90	94	94
Sound pressure levels at 10 meters (3)	dB(A)	52	52	54	54	57	57	58	62	62

(1) Data based on 5 °C evaporating temperature and 35 °C ambient air temperature.

(2) Maximum power input includes : maximum compressor power input and maximum fan power input.

(3) Sound pressure level values refer to ISO standard 3744.

Physical Data - CLC LN

CLC LN sizes		182	202	242	302	352	402	502	552	602
Nominal cooling capacity (1)	kW	40.9	54.1	64.9	74.3	90.0	105.3	121.4	130.7	140.0
Compressor power input	kW	12.3	18.2	24.2	27.7	33.2	37.5	46.2	52.6	59.0
Maximum power input (2)	kW	19.3	25.9	30.4	36.0	43.2	49.7	60.1	65.4	72.5
EER		3.3	3.0	2.7	2.7	2.7	2.8	2.6	2.5	2.4
Number of refrigerant circuits		2	2	2	2	2	2	2	2	2
Total unit capacity steps	%	50/100	50/100	50/100	50/100	43-57/100	50/100	50/100	43-57/100	50/100
REFRIGERANT										
Type		HFC 407C								
Charge	kg	Nitrogen								
COMPRESSORS										
Number		2	2	2	2	2	2	2	2	2
Type		Scroll	Scroll	Scroll	Scroll	Scroll	Scroll	Scroll	Scroll	Scroll
AIR COOLED CONDENSERS										
Number		2	2	2	2	2	2	2	2	2
Total coil face area per coil	m ²	2.1	2.1	2.1	2.1	2.85	2.85	3.6	3.6	3.6
Number of rows		2	2	3	4	3	4	4	5	5
FANS										
Number		2	2	2	2	3	3	3	3	3
Total air flow	m ³ /h	21000	21000	21000	20100	30500	29000	31500	31500	31500
Power input	kW	1.4	1.4	1.4	1.4	2.1	2.1	2.1	2.1	2.1
REFRIGERANT CONNECTIONS										
Liquid line	inch	1/2"	1/2"	5/8"	5/8"	5/8"	5/8"	5/8"	5/8"	5/8"
Suction line	inch	7/8"	7/8"	1"5/8"	1"5/8"	1"5/8"	1"5/8"	1"5/8"	1"5/8"	1"5/8"
DIMENSIONS										
Length	mm	2110	2110	2110	2110	2760	2760	3110	3110	3110
Width	mm	1110	1110	1110	1110	1110	1110	1110	1110	1110
Height	mm	1850	1850	1850	1850	1850	1850	1850	1850	1850
WEIGHT										
Shipping	kg	578	603	730	776	841	907	995	1131	1167
SOUND LEVELS										
Sound power levels	dB(A)	80	80	82	82	85	85	86	86	86
Sound pressure levels at 10 meters (3)	dB(A)	48	48	50	50	53	53	54	54	54

(1) Data based on 5 °C evaporating temperature and 35 °C ambient air temperature.

(2) Maximum power input includes : maximum compressor power input and maximum fan power input.

(3) Sound pressure level values refer to ISO standard 3744.

Physical Data - CLC ELN

CLC ELN sizes		182	202	242	302	352	402	502	552	602
Nominal cooling capacity (1)	kW	40.8	54.1	63.8	69.4	88.9	99.1	121.4	130.7	140.0
Compressor power input	kW	12.3	18.2	24.7	30.2	33.8	40.8	46.2	52.6	59.0
Maximum power input (2)	kW	19.3	25.9	30.4	36.0	43.2	49.7	60.1	65.4	72.5
EER		3.3	3.0	2.6	2.3	2.6	2.4	2.6	2.5	2.4
Number of refrigerant circuits		2	2	2	2	2	2	2	2	2
Total unit capacity steps	%	50/100	50/100	50/100	50/100	43-57/100	50/100	50/100	43-57/100	50/100
REFRIGERANT										
Type		HFC 407C								
Charge	kg	Nitrogen								
COMPRESSORS										
Number		2	2	2	2	2	2	2	2	2
Type		Scroll	Scroll	Scroll	Scroll	Scroll	Scroll	Scroll	Scroll	Scroll
AIR COOLED CONDENSERS										
Number		2	2	2	2	2	2	2	2	2
Total coil face area per coil	m ²	2.1	2.1	2.1	2.1	2.85	2.85	3.6	3.6	3.6
Number of rows		3	3	4	4	4	4	4	5	5
FANS										
Number		2	2	2	2	3	3	3	3	3
Total air flow	m ³ /h	14400	14400	14400	13800	20100	19900	24000	23500	23500
Power input	kW	1.4	1.4	1.4	1.4	2.1	2.1	2.1	2.1	2.1
REFRIGERANT CONNECTIONS										
Liquid line	inch	1/2"	1/2"	5/8"	5/8"	5/8"	5/8"	5/8"	5/8"	5/8"
Suction line	inch	7/8"	7/8"	1"5/8"	1"5/8"	1"5/8"	1"5/8"	1"5/8"	1"5/8"	1"5/8"
DIMENSIONS										
Length	mm	2110	2110	2110	2110	2760	2760	3110	3110	3110
Width	mm	1110	1110	1110	1110	1110	1110	1110	1110	1110
Height	mm	1850	1850	1850	1850	1850	1850	1850	1850	1850
WEIGHT										
Shipping	kg	620	641	772	786	903	919	1015	1151	1187
SOUND LEVELS										
Sound power levels	dB(A)	77	77	78	78	79	81	82	82	82
Sound pressure levels at 10 meters (3)	dB(A)	45	45	46	46	47	49	50	50	50

(1) Data based on 5 °C evaporating temperature and 35 °C ambient air temperature.

(2) Maximum power input includes : maximum compressor power input and maximum fan power input.

(3) Sound pressure level values refer to ISO standard 3744.

Physical Data - CLC HPF

CLC HPF sizes		182	202	242	302	352	402	502	552	602
Nominal cooling capacity (1)	kW	40.9	54.1	64.9	74.3	90.0	105.3	121.4	130.7	140.0
Compressor power input	kW	12.3	18.2	24.2	27.7	33.2	37.5	46.2	52.6	59.0
Maximum power input (2)	kW	19.8	26.4	31.0	36.6	44.0	50.5	60.9	65.4	72.5
EER		3.3	3.0	2.7	2.7	2.7	2.8	2.6	2.5	2.4
Number of refrigerant circuits		2	2	2	2	2	2	2	2	2
Total unit capacity steps	%	50/100	50/100	50/100	50/100	43-57/100	50/100	50/100	43-57/100	50/100
REFRIGERANT										
Type		HFC 407C								
Charge	kg	Nitrogen								
COMPRESSORS										
Number		2	2	2	2	2	2	2	2	2
Type		Scroll	Scroll	Scroll	Scroll	Scroll	Scroll	Scroll	Scroll	Scroll
AIR COOLED CONDENSERS										
Number		2	2	2	2	2	2	2	2	2
Total coil face area per coil	m ²	2.1	2.1	2.1	2.1	2.85	2.85	3.6	3.6	3.6
Number of rows		2	2	3	4	3	4	4	5	5
FANS										
Number		2	2	2	2	3	3	3	3	3
Total air flow	m ³ /h	21000	21000	20300	19700	30000	28700	30000	30000	30000
Power input	kW	1.96	1.96	1.96	1.96	2.94	2.94	2.94	2.94	2.94
REFRIGERANT CONNECTIONS										
Liquid line	inch	1/2"	1/2"	5/8"	5/8"	5/8"	5/8"	5/8"	5/8"	5/8"
Suction line	inch	7/8"	7/8"	1"5/8"	1"5/8"	1"5/8"	1"5/8"	1"5/8"	1"5/8"	1"5/8"
DIMENSIONS										
Length	mm	2100	2100	2100	2100	2760	2760	3110	3110	3110
Width	mm	1110	1110	1110	1110	1110	1110	1110	1110	1110
Height	mm	1850	1850	1850	1850	1850	1850	1850	1850	1850
WEIGHT										
Shipping	kg	578	603	730	776	841	907	995	1131	1167
SOUND LEVELS										
Sound power levels	dB(A)	87	87	89	89	92	92	93	93	93
Sound pressure levels at 10 meters (3)	dB(A)	55	55	57	57	60	60	61	61	61

(1) Data based on 5 °C evaporating temperature and 35 °C ambient air temperature.

(2) Maximum power input includes : maximum compressor power input and maximum fan power input.

(3) Sound pressure level values refer to ISO standard 3744.

Physical Data - CLC SIF

CLC SIF sizes		352	402	502	552	602
Nominal cooling capacity (1)	kW	90.0	105.3	121.4	130.7	140.0
Compressor power input	kW	33.2	37.5	46.2	52.6	59.0
Maximum power input (2)	kW	44.0	50.5	60.9	65.4	72.5
EER		2.7	2.8	2.6	2.5	2.4
Number of refrigerant circuits		2	2	2	2	2
Total unit capacity steps	%	43-57/100	50/100	50/100	43-57/100	50/100
REFRIGERANT						
Type		HFC 407C				
Charge	kg	Nitrogen				
COMPRESSORS						
Number		2	2	2	2	2
Type		Scroll	Scroll	Scroll	Scroll	Scroll
AIR COOLED CONDENSERS						
Number		2	2	2	2	2
Total coil face area per coil	m ²	2.85	2.85	3.6	3.6	3.6
Number of rows		3	4	4	5	5
FANS						
Number		2	2	2	2	2
Total air flow	m ³ /h	30000	28700	30000	30000	30000
Power input	kW	5.2	5.2	5.2	5.2	5.2
REFRIGERANT CONNECTIONS						
Liquid line	inch	5/8"	5/8"	5/8"	5/8"	5/8"
Suction line	inch	1"5/8	1"5/8	1"5/8	1"5/8	1"5/8
DIMENSIONS						
Length	mm	2760	2760	3110	3110	3110
Width	mm	1110	1110	1110	1110	1110
Height	mm	1850	1850	1850	1850	1850
WEIGHT						
Shipping	kg	841	907	995	1131	1167
SOUND LEVELS						
Sound power levels	dB(A)	92.5	94	94	95	95
Sound pressure levels at 10 meters (3)	dB(A)	60.5	62	62	63	63

(1) Data based on 5 °C evaporating temperature and 35 °C ambient air temperature.

(2) Maximum power input includes : maximum compressor power input and maximum fan power input.

(3) Sound pressure level values refer to ISO standard 3744.

Physical Data - CLC HT

CLC HT sizes		182	202	242	302	352	402	502	552	602
Nominal cooling capacity (1)	kW	43.9	58.3	70.0	79.4	93.4	109.2	125.9	135.5	145.0
Compressor power input	kW	12.2	17.7	23.3	25.9	31.8	35.8	44.3	50.4	56.5
Maximum power input (2)	kW	19.8	26.4	31.0	36.6	44.0	50.5	60.9	65.4	72.5
EER		3.6	3.3	3.0	3.1	2.9	3.1	2.8	2.7	2.6
Number of refrigerant circuits		2	2	2	2	2	2	2	2	2
Total unit capacity steps	%	50/100	50/100	50/100	50/100	43-57/100	50/100	50/100	43-57/100	50/100
REFRIGERANT										
Type		HFC 407C								
Charge	kg	Nitrogen								
COMPRESSORS										
Number		2	2	2	2	2	2	2	2	2
Type		Scroll	Scroll	Scroll	Scroll	Scroll	Scroll	Scroll	Scroll	Scroll
AIR COOLED CONDENSERS										
Number		2	2	2	2	2	2	2	2	2
Total coil face area per coil	m ²	2.1	2.1	2.1	2.1	2.85	2.85	3.6	3.6	3.6
Number of rows		2	2	3	4	3	4	4	5	5
FANS										
Number		2	2	2	2	3	3	3	3	3
Total air flow	m ³ /h	36700	36700	35500	25500	38800	37200	39600	30000	30000
Power input	kW	1.96	1.96	1.96	1.96	2.94	2.94	2.94	2.94	2.94
REFRIGERANT CONNECTIONS										
Liquid line	inch	1/2"	1/2"	5/8"	5/8"	5/8"	5/8"	5/8"	5/8"	5/8"
Suction line	inch	7/8"	7/8"	1"5/8"	1"5/8"	1"5/8"	1"5/8"	1"5/8"	1"5/8"	1"5/8"
DIMENSIONS										
Length	mm	2100	2100	2100	2100	2760	2760	3110	3110	3110
Width	mm	1110	1110	1110	1110	1110	1110	1110	1110	1110
Height	mm	1850	1850	1850	1850	1850	1850	1850	1850	1850
WEIGHT										
Shipping	kg	578	603	730	776	841	907	995	1131	1167
SOUND LEVELS										
Sound power levels	dB(A)	87	87	89	89	92	92	93	93	93
Sound pressure levels at 10 meters (3)	dB(A)	55	55	57	57	60	60	61	61	61

(1) Data based on 5 °C evaporating temperature and 35 °C ambient air temperature.

(2) Maximum power input includes : maximum compressor power input and maximum fan power input.

(3) Sound pressure level values refer to ISO standard 3744.

Fan External Static Pressure - CLC SIF

Sizes	External static pressure (Pa)	Fan speed (rpm)	Sound power levels (dBA)
CLC 352	42	900	91
	75	950	91
	100	1000	91
	150	1050	92.5
	190	1150	95
CLC 402	50	900	91
	80	950	91
	100	1000	91
	130	1050	92.5
	150	1100	94
CLC 502	32	900	91
	65	950	91
	95	1000	91
	120	1050	92.5
	150	1100	94
	180	1150	95
CLC 552	22	900	91
	55	950	91
	85	1000	91
	110	1050	92.5
	150	1100	94
	170	1150	95
CLC 602	22	900	91
	55	950	91
	85	1000	91
	110	1050	92.5
	150	1100	94
	170	1150	95

Electrical Data

Compressors @ 400 V / 3 Ph / 50 Hz

CLC Models		Power input at nominal conditions per compressor (kW)	Current at nominal conditions per compressor (A)	Power input at max. conditions per compressor (kW)	Current at max. conditions per compressor FLA (A)	Start up current LRA (A)	Power factor at nominal conditions	Crankcase heater @ 230 V/1Ø (W)	Unit fuse size (A)	Cable section (mm ²)
182	Circuit 1	6	10.1	9	15	99	0.84	70	50	16
	Circuit 2	6	10.1	9	15	99	0.84	70		
202	Circuit 1	8.5	14.4	12	21	127	0.84	70	63	25
	Circuit 2	8.5	14.4	12	21	127	0.84	70		
242	Circuit 1	12	20	15	24	150	0.87	65	63	25
	Circuit 2	12	20	15	24	150	0.87	65		
302	Circuit 1	13.7	24.3	17	29	175	0.81	75	80	35
	Circuit 2	13.7	24.3	17	29	175	0.81	75		
352	Circuit 1	13.7	24.3	17	29	175	0.81	75	100	35
	Circuit 2	18.6	31.4	24	38.5	215	0.86	130		
402	Circuit 1	18.6	31.4	24	38.5	215	0.86	130	100	35
	Circuit 2	18.6	31.4	24	38.5	215	0.86	130		
502	Circuit 1	23	38.5	29	47	270	0.86	130	125	50
	Circuit 2	23	38.5	29	47	270	0.86	130		
552	Circuit 1	20.3	34.3	28	48	272	0.84	150	125	70
	Circuit 2	25.3	44.2	35	58.5	320	0.83	150		
602	Circuit 1	25.3	44.2	35	58.5	320	0.83	150	160	70
	Circuit 2	25.3	44.2	35	58.5	320	0.83	150		

Units @ 400 V / 3 Ph / 50 Hz

CLC STD models		182	202	242	302	352	402	502	552	602
Nominal current input	A	22.2	30.6	41.9	50.5	58.5	65.6	79.8	82.7	92.6
Maximum current input	A	32.1	43.3	49.9	59.9	70.3	79.8	97.2	113.7	128.2
Nominal power input	kW	13.0	18.0	25.0	28.4	33.7	38.6	47.5	47.7	52.7
Maximum power input	kW	18.8	25.4	30.0	35.6	42.5	49.0	59.4	65.4	72.5
Starting current (LRA)	A	116	150	176	206	247	256	320	372	386

CLC LN / ELN models		182	202	242	302	352	402	502	552	602
Nominal current input	A	22.6	31.0	42.3	50.9	59.2	66.3	80.5	82.0	91.9
Maximum current input	A	32.5	43.7	50.3	60.3	71.0	80.5	97.9	109.5	120.5
Nominal power input	kW	13.4	18.4	25.4	28.8	34.4	39.3	48.1	47.7	52.7
Maximum power input	kW	19.3	25.9	30.4	36.0	43.2	49.7	60.1	65.4	72.5
Starting current (LRA)	A	116	150	176	206	247	257	321	371	382

CLC HPF / HT models		182	202	242	302	352	402	502	552	602
Nominal current input	A	23.7	32.1	43.4	52.0	60.8	67.9	82.1	83.6	93.5
Maximum current input	A	33.6	44.8	51.4	61.4	72.6	82.1	99.5	111.1	122.1
Nominal power input	kW	14.0	19.0	26.0	29.4	35.2	40.1	49.0	48.5	53.5
Maximum power input	kW	19.8	26.4	31.0	36.6	44.0	50.5	60.9	64.7	73.3
Starting current (LRA)	A	118	151	177	207	249	259	322	373	384

CLC SIF models		352	402	502	552	602
Nominal current input	A	64.7	71.8	90.5	87.5	97.4
Maximum current input	A	76.5	86.0	107.9	118.5	133.0
Nominal power input	kW	37.5	42.4	53.8	50.8	55.8
Maximum power input	kW	46.3	52.8	65.8	68.5	75.6
Starting current (LRA)	A	253	263	331	377	391

Sound Levels

Sound power levels Lw-dB(A)

CLC STD sizes	Frequency (Hz)							Lw global dB(A)
	125	250	500	1000	2000	4000	8000	
182 STD	84	82	81	80	78	68	57	84
202 STD	84	82	81	80	78	68	57	84
242 STD	86	84	83	82	80	70	59	86
302 STD	86	84	83	82	80	70	59	86
352 STD	89	87	86	85	83	73	62	89
402 STD	89	87	86	85	83	73	62	89
502 STD	90	88	87	86	84	74	63	90
552 STD	94	92	91	90	88	78	67	94
602 STD	94	92	91	90	88	78	67	94

CLC LN sizes	Frequency (Hz)							Lw global dB(A)
	125	250	500	1000	2000	4000	8000	
182 LN	80	78	77	76	74	64	53	80
202 LN	80	78	77	76	74	64	53	80
242 LN	82	80	79	78	76	66	55	82
302 LN	82	80	79	78	76	66	55	82
352 LN	85	83	82	81	79	69	58	85
402 LN	85	83	82	81	79	69	58	85
502 LN	86	84	83	82	80	70	59	86
552 LN	86	84	83	82	80	70	59	86
602 LN	86	84	83	82	80	70	59	86

CLC ELN sizes	Frequency (Hz)							Lw global dB(A)
	125	250	500	1000	2000	4000	8000	
182 ELN	77	75	74	73	71	61	50	77
202 ELN	77	75	74	73	71	61	50	77
242 ELN	78	76	75	74	72	62	51	78
302 ELN	78	76	75	74	72	62	51	78
352 ELN	79	77	76	75	73	63	52	79
402 ELN	81	79	78	77	75	65	54	81
502 ELN	82	80	79	78	76	66	55	82
552 ELN	82	80	79	78	76	66	55	82
602 ELN	82	80	79	78	76	66	55	82

CLC HPF/HT sizes	Frequency (Hz)							Lw global dB(A)
	125	250	500	1000	2000	4000	8000	
182	87	85	84	83	81	71	60	87
202	87	85	84	83	81	71	60	87
242	89	87	86	85	83	73	62	89
302	89	87	86	85	83	73	62	89
352	92	90	89	88	86	76	65	92
402	92	90	89	88	86	76	65	92
502	93	91	90	89	87	77	66	93
552	93	91	90	89	87	77	66	93
602	93	91	90	89	87	77	66	93

CLC SIF sizes	Frequency (Hz)							Lw global dB(A)
	125	250	500	1000	2000	4000	8000	
352 SIF	92.5	90.5	89.5	88.5	86.5	76.5	65.5	92.5
402 SIF	94	92	91	90	88	78	67	94
502 SIF	94	92	91	90	88	78	67	94
552 SIF	95	93	92	91	89	79	68	95
602 SIF	95	93	92	91	89	79	68	95

Sound pressure levels Lp-dB(A)

CLC STD sizes	Frequency (Hz)							Lp* global dB(A)
	125	250	500	1000	2000	4000	8000	
182 STD	52	50	49	48	46	36	25	52
202 STD	52	50	49	48	46	36	25	52
242 STD	54	52	51	50	48	38	27	54
302 STD	54	52	51	50	48	38	27	54
352 STD	57	55	54	53	51	41	30	57
402 STD	57	55	54	53	51	41	30	57
502 STD	58	56	55	54	52	42	31	58
552 STD	62	60	59	60	56	46	35	62
602 STD	62	60	59	60	56	46	35	62

CLC LN sizes	Frequency (Hz)							Lp* global dB(A)
	125	250	500	1000	2000	4000	8000	
182 LN	48	46	45	44	42	32	21	48
202 LN	48	46	45	44	42	32	21	48
242 LN	50	48	47	46	44	34	23	50
302 LN	50	48	47	46	44	34	23	50
352 LN	53	51	50	49	47	37	26	53
402 LN	53	51	50	49	47	37	26	53
502 LN	54	52	51	50	48	38	27	54
552 LN	54	52	51	50	48	38	27	54
602 LN	54	52	51	50	48	38	27	54

CLC ELN sizes	Frequency (Hz)							Lp* global dB(A)
	125	250	500	1000	2000	4000	8000	
182 ELN	45	43	42	41	39	29	18	45
202 ELN	45	43	42	41	39	29	18	45
242 ELN	46	44	43	42	40	30	19	46
302 ELN	46	44	43	42	40	30	19	46
352 ELN	47	45	44	43	41	31	20	47
402 ELN	49	47	46	45	43	33	22	49
502 ELN	50	48	47	46	44	34	23	50
552 ELN	50	48	47	46	44	34	23	50
602 ELN	50	48	47	46	44	34	23	50

CLC HPF/HT sizes	Frequency (Hz)							Lp* global dB(A)
	125	250	500	1000	2000	4000	8000	
182	55	53	52	51	49	39	28	55
202	55	53	52	51	49	39	28	55
242	57	55	54	53	51	41	30	57
302	57	55	54	53	51	41	30	57
352	60	58	57	56	54	44	33	60
402	60	58	57	56	54	44	33	60
502	61	59	58	57	55	45	34	61
552	61	59	58	57	55	45	34	61
602	61	59	58	57	55	45	34	61

CLC SIF sizes	Frequency (Hz)							Lp* global dB(A)
	125	250	500	1000	2000	4000	8000	
352 SIF	60.5	58.5	57.5	56.5	54.5	44.5	33.5	60.5
402 SIF	62	60	59	58	56	46	35	62
502 SIF	62	60	59	58	56	46	35	62
552 SIF	63	61	60	59	57	47	36	63
602 SIF	63	61	60	59	57	47	36	63

* Sound pressure levels are given for a distance of 10 meters, according to ISO 3744. Directivity factor Q=2. Tolerance = 2 dB.

Cooling Capacities - CLC 182 ÷ 352 STD/LN/HPF/SIF*

CLC MODELS	Evap. Temp. (°C)	AMBIENT AIR TEMPERATURE (°C)													
		25		30		32		35		40		43		46	
		Cool. Cap. (kW)	Power Input (kW)	Cool. Cap. (kW)	Power Input (kW)	Cool. Cap. (kW)	Power Input (kW)	Cool. Cap. (kW)	Power Input (kW)	Cool. Cap. (kW)	Power Input (kW)	Cool. Cap. (kW)	Power Input (kW)	Cool. Cap. (kW)	Power Input (kW)
182	-8	32.7	8.6	31.6	10.9	31.1	9.8	30.3	10.2	27.7	11.5	23.9	12.4	24.1	12.7
	-4	36.1	9.2	34.9	12.0	34.3	10.4	33.5	10.9	30.7	12.2	27.5	13.0	27.4	13.3
	0	39.5	9.8	38.2	13.1	37.6	11.0	36.7	11.5	33.7	12.9	31.2	13.7	30.7	14.0
	4	42.3	10.4	40.9	11.4	40.4	11.7	39.3	12.2	36.2	13.6	34.0	14.3	33.3	14.8
	5	44.0	10.5	42.5	11.5	42.0	11.8	40.9	12.3	37.6	13.7	35.4	14.5	34.7	15.0
	6	44.8	10.6	43.4	11.6	42.8	11.9	41.7	12.5	38.3	13.9	37.7	14.6	36.4	15.2
	8	46.5	10.9	44.9	31.4	44.4	12.2	43.2	12.8	39.8	14.2	39.1	15.0		
	10	48.0	11.2	46.5	12.2	45.9	12.6	44.7	13.1	41.2	14.6	40.5	15.3		
	13	50.3	11.7	48.6	12.8	48.1	13.0	46.8	13.6	43.2	15.1	42.5	15.8		
202	-8	43.2	12.8	41.8	16.2	41.1	14.5	40.0	15.1	36.6	17.0	31.6	18.3	31.9	18.8
	-4	47.7	13.6	46.2	17.8	45.4	15.4	44.3	16.1	40.6	18.0	36.4	19.3	36.3	19.7
	0	52.2	14.5	50.5	19.4	49.8	16.3	48.5	17.0	44.5	19.0	41.3	20.2	40.6	20.7
	4	55.9	15.4	54.1	16.8	53.4	17.2	52.0	18.0	47.8	20.1	44.9	21.2	44.1	22.0
	5	58.2	15.6	56.2	17.0	55.5	17.5	54.1	18.2	49.8	20.3	46.8	21.4	45.9	22.2
	6	59.3	15.8	57.3	17.2	56.6	17.7	55.1	18.4	50.7	20.6	49.8	21.7	48.1	22.5
	8	61.5	16.2	59.4	46.5	58.7	18.1	57.2	18.9	52.6	21.1	51.7	22.1		
	10	63.5	16.6	61.4	18.1	60.7	18.6	59.2	19.4	54.5	21.6	53.6	22.6		
	13	66.5	17.3	64.3	18.9	63.6	19.3	62.0	20.1	57.1	22.4	56.2	23.3		
242	-8	51.7	16.9	50.0	21.5	49.3	19.2	48.0	20.0	43.9	22.5	37.9	24.4	38.2	25.0
	-4	57.1	18.1	55.2	23.6	54.5	20.4	53.1	21.3	48.6	23.9	43.7	25.7	43.5	26.3
	0	62.5	19.2	60.5	25.7	59.7	21.6	58.2	22.6	53.4	25.3	49.5	26.9	48.7	27.6
	4	67.0	20.4	64.8	22.3	64.0	22.9	62.4	23.9	57.3	26.7	53.9	28.2	52.9	29.2
	5	69.8	20.7	67.4	22.6	66.5	23.2	64.9	24.2	59.7	27.0	56.1	28.5	55.0	29.5
	6	71.1	20.9	68.7	22.9	67.9	23.5	66.1	24.5	60.7	27.3	59.7	28.8	57.7	29.9
	8	73.7	21.5	71.3	61.7	70.4	24.1	68.6	25.1	63.1	28.0	62.0	29.4		
	10	76.2	22.1	73.7	24.1	72.7	24.7	70.9	25.8	65.3	28.7	64.2	30.1		
	13	79.8	23.0	77.1	25.1	76.2	25.7	74.3	26.8	68.4	29.8	67.3	31.0		
302	-8	59.4	19.5	57.4	24.7	56.5	22.0	55.0	23.1	50.3	25.9	43.4	27.9	43.8	28.6
	-4	65.6	20.8	63.4	27.1	62.4	23.4	60.8	24.5	55.7	27.4	50.0	29.3	49.8	30.1
	0	71.7	22.1	69.3	29.5	68.3	24.8	66.6	25.9	61.1	29.0	56.6	30.8	55.8	31.6
	4	76.8	23.4	74.2	25.6	73.3	26.2	71.4	27.4	65.6	30.6	61.7	32.2	60.5	33.4
	5	79.9	23.7	77.2	25.9	76.2	26.6	74.3	27.7	68.3	30.9	64.2	32.6	63.0	33.8
	6	81.4	24.0	78.7	26.2	77.7	26.9	75.7	28.1	69.5	31.3	68.4	33.0	66.1	34.2
	8	84.4	24.6	81.6	70.7	80.6	27.6	78.5	28.7	72.2	32.1	71.0	33.7		
	10	87.2	25.3	84.3	27.6	83.2	28.3	81.2	29.5	74.7	32.8	73.5	34.4		
	13	91.3	26.3	88.2	28.7	87.3	29.4	85.0	30.6	78.3	34.1	77.1	35.5		
352	-8	71.9	23.3	69.5	29.6	68.4	26.4	66.6	27.5	60.8	31.1	52.5	33.3	52.9	34.2
	-4	79.4	24.9	76.7	32.5	75.6	28.1	73.6	29.3	67.4	32.9	60.5	35.1	60.2	36.0
	0	86.8	26.4	83.9	35.4	82.8	29.7	80.7	31.0	74.0	34.8	68.5	36.9	67.5	37.8
	4	93.0	28.0	89.9	30.7	88.8	31.4	86.5	32.8	79.5	36.6	74.7	38.6	73.3	40.0
	5	96.8	28.4	93.5	31.0	92.3	31.9	90.0	33.2	82.7	37.1	77.8	39.1	76.3	40.5
	6	98.6	28.7	95.3	31.4	94.1	32.2	91.7	33.6	84.2	37.5	82.8	39.5	80.0	41.0
	8	102.2	29.5	98.8	84.7	97.6	33.0	95.1	34.4	87.5	38.5	86.0	40.4		
	10	105.6	30.3	102.1	33.0	100.8	33.9	98.4	35.4	90.5	39.3	89.1	41.3		
	13	110.6	31.5	106.9	34.4	105.7	35.2	103.0	36.7	94.9	40.8	93.4	42.6		

Notes : - Power input data are given for compressors only.
 * SIF version for sizes 352 to 602 only.

Cooling Capacities - CLC 402 ÷ 602 STD/LN/HPF/SIF*

CLC MODELS	Evap. Temp. (°C)	AMBIENT AIR TEMPERATURE (°C)													
		25		30		32		35		40		43		46	
		Cool. Cap. (kW)	Power Input (kW)	Cool. Cap. (kW)	Power Input (kW)	Cool. Cap. (kW)	Power Input (kW)	Cool. Cap. (kW)	Power Input (kW)	Cool. Cap. (kW)	Power Input (kW)	Cool. Cap. (kW)	Power Input (kW)	Cool. Cap. (kW)	Power Input (kW)
402	-8	84.1	26.5	81.4	33.3	80.0	29.8	77.9	31.1	71.3	35.1	61.5	37.6	62.1	38.5
	-4	92.9	28.2	89.8	36.5	88.4	31.7	86.1	33.1	78.9	37.2	70.9	39.6	70.6	40.6
	0	101.6	29.9	98.2	39.8	96.8	33.6	94.3	35.1	86.6	39.3	80.2	41.6	79.1	42.6
	4	108.8	31.7	105.2	34.6	103.9	35.5	101.2	37.1	93.0	41.4	87.4	43.6	85.8	45.2
	5	113.3	32.1	109.4	35.0	108.0	36.0	105.3	37.5	96.8	41.9	91.0	44.1	89.3	45.7
	6	115.3	32.5	111.5	35.4	110.1	36.4	107.2	38.0	98.6	42.3	96.9	44.6	93.6	46.3
	8	119.6	33.3	115.6	35.7	114.2	37.3	111.2	38.9	102.3	43.4	100.6	45.6		
	10	123.6	34.2	119.5	37.3	118.0	38.3	115.1	40.0	105.9	44.4	104.2	46.6		
	13	129.4	35.6	125.0	38.9	123.7	39.8	120.5	41.5	111.0	46.1	109.2	48.1		
502	-8	97.0	32.4	93.8	41.1	92.2	36.9	89.8	38.4	82.2	43.2	71.0	46.6		
	-4	107.0	34.6	103.6	45.1	101.9	39.2	99.2	40.8	91.0	45.8	81.8	49.0		
	0	117.1	36.8	113.3	49.2	111.6	41.5	108.7	43.2	99.8	48.4	92.6	51.4		
	4	125.4	39.0	121.3	42.7	119.7	43.8	116.7	45.7	107.3	51.0	100.8	53.8		
	5	130.6	39.5	126.1	43.2	124.5	44.4	121.4	46.2	111.6	51.6	104.9	54.4		
	6	133.0	40.0	128.6	43.6	126.9	44.9	123.6	46.8	113.6	52.2	111.8	55.0		
	8	137.9	41.1	133.3	44.1	131.7	46.0	128.2	47.9	118.0	53.5				
	10	142.5	42.2	137.8	46.0	136.0	47.2	132.7	49.2	122.1	54.7				
	13	149.2	43.9	144.1	47.9	142.6	49.0	139.0	51.1	128.0	56.8				
552	-8	104.3	36.9	101.0	46.8	99.2	41.9	96.7	43.7	88.5	49.1	76.3	52.9		
	-4	115.2	39.4	111.4	51.4	109.7	44.5	106.9	46.5	98.0	52.0	87.9	55.7		
	0	126.1	41.9	121.9	55.9	120.2	47.2	117.1	49.2	107.5	55.0	99.6	58.4		
	4	135.0	44.4	130.6	48.6	128.9	49.8	125.6	52.0	115.5	58.0	108.5	61.2		
	5	140.6	45.0	135.8	49.1	134.0	50.5	130.7	52.6	120.2	58.7	112.9	61.9		
	6	143.1	45.5	138.4	49.7	136.7	51.1	133.1	53.3	122.3	59.4	120.3	62.6		
	8	148.5	46.8	143.5	50.6	141.7	52.3	138.1	54.5	127.0	60.9				
	10	153.4	48.0	148.3	52.3	146.4	53.7	142.9	56.1	131.5	62.3				
	13	160.6	50.0	155.2	54.5	153.5	55.8	149.6	58.2	137.8	64.7				
602	-8	111.8	41.4	108.1	52.5	106.3	47.0	103.6	49.1	94.8	55.1	81.7	59.3		
	-4	123.4	44.2	119.4	57.6	117.5	49.9	114.5	52.1	104.9	58.4	94.2	62.4		
	0	135.0	47.0	130.6	62.8	128.7	52.9	125.4	55.2	115.1	61.7	106.7	65.5		
	4	144.6	49.8	139.9	54.5	138.1	55.9	134.6	58.4	123.7	65.1	116.2	68.7		
	5	150.6	50.4	145.4	55.1	143.5	56.7	140.0	59.0	128.7	65.8	121.0	69.4		
	6	153.3	51.1	148.3	55.7	146.4	57.3	142.6	59.8	131.0	66.6	128.9	70.2		
	8	159.0	52.5	153.7	56.8	151.8	58.7	147.9	61.2	136.1	68.3				
	10	164.3	53.9	158.9	58.7	156.9	60.2	153.0	62.9	140.8	69.9				
	13	172.1	56.0	166.2	61.2	164.5	62.6	160.3	65.2	147.6	72.5				

Notes : - Power input data are given for compressors only.
 * SIF version for sizes 352 to 602 only.

Cooling Capacities - CLC 182 ÷ 352 ELN

CLC MODELS	Evap. Temp. (°C)	AMBIENT AIR TEMPERATURE (°C)													
		25		30		32		35		40		43		46	
		Cool. Cap. (kW)	Power Input (kW)	Cool. Cap. (kW)	Power Input (kW)	Cool. Cap. (kW)	Power Input (kW)	Cool. Cap. (kW)	Power Input (kW)	Cool. Cap. (kW)	Power Input (kW)	Cool. Cap. (kW)	Power Input (kW)	Cool. Cap. (kW)	Power Input (kW)
182 ELN	-8	32.6	8.7	31.5	11.0	31.0	9.8	30.2	10.3	27.6	11.5	23.8	12.4	24.0	12.7
	-4	36.0	9.2	34.8	12.1	34.3	10.4	33.4	10.9	30.6	12.2	27.5	13.1	27.3	13.4
	0	39.4	9.8	38.1	13.1	37.5	11.1	36.6	11.5	33.6	12.9	31.1	13.7	30.6	14.0
	4	42.2	10.4	40.8	11.4	40.3	11.7	39.2	12.2	36.1	13.6	33.9	14.4	33.3	14.9
	5	43.9	10.6	42.4	11.5	41.9	11.9	40.8	12.3	37.5	13.8	35.3	14.5	34.6	15.1
	6	44.7	10.7	43.2	11.7	42.7	12.0	41.6	12.5	38.2	13.9	37.6	14.7	36.3	15.2
	8	46.4	11.0	44.8	31.5	44.3	12.3	43.1	12.8	39.7	14.3	39.0	15.0		
	10	47.9	11.3	46.3	12.3	45.7	12.6	44.6	13.2	41.1	14.6	40.4	15.3		
	13	50.2	11.7	48.5	12.8	48.0	13.1	46.7	13.6	43.0	15.2	42.4	15.8		
202 ELN	-8	43.2	12.8	41.8	16.2	41.1	14.5	40.0	15.1	36.6	17.0	31.6	12.4	31.9	12.7
	-4	47.7	13.6	46.1	17.8	45.4	15.4	44.3	16.1	40.6	18.0	36.4	13.1	36.2	13.4
	0	52.2	14.5	50.5	19.4	49.8	16.3	48.5	17.0	44.5	19.1	41.2	13.7	40.6	14.0
	4	55.9	15.4	54.1	16.8	53.4	17.3	52.0	18.0	47.8	20.1	44.9	14.4	44.1	14.9
	5	58.2	15.6	56.2	17.0	55.5	17.5	54.1	18.2	49.8	20.3	46.8	14.5	45.9	15.1
	6	59.3	15.8	57.3	17.2	56.6	17.7	55.1	18.5	50.7	20.6	49.8	14.7	48.1	15.2
	8	61.5	16.2	59.4	46.5	58.7	18.1	57.2	18.9	52.6	21.1	51.7	15.0		
	10	63.5	16.6	61.4	18.1	60.6	18.6	59.2	19.4	54.4	21.6	53.6	15.3		
	13	66.5	17.3	64.3	18.9	63.6	19.3	61.9	20.1	57.1	22.4	56.1	15.8		
242 ELN	-8	50.9	17.4	49.2	22.0	48.4	19.7	47.2	20.5	43.2	23.0	37.2	24.8	37.6	25.5
	-4	56.2	18.5	54.4	24.1	53.5	20.9	52.2	21.8	47.8	24.4	42.9	26.1	42.8	26.8
	0	61.5	19.7	59.5	26.3	58.6	22.1	57.2	23.1	52.5	25.8	48.6	27.4	47.9	28.1
	4	65.9	20.9	63.7	22.8	62.9	23.4	61.3	24.4	56.4	27.2	53.0	28.7	52.0	29.8
	5	68.6	21.1	66.3	23.1	65.4	23.7	63.8	24.7	58.7	27.6	55.1	29.1	54.1	30.1
	6	69.9	21.4	67.6	23.3	66.7	24.0	65.0	25.0	59.7	27.9	58.7	29.4	56.7	30.5
	8	72.5	22.0	70.1	63.0	69.2	24.6	67.4	25.6	62.0	28.6	61.0	30.0		
	10	74.9	22.5	72.4	24.6	71.5	25.2	69.7	26.3	64.2	29.3	63.1	30.7		
	13	78.4	23.5	75.8	25.6	74.9	26.2	73.0	27.3	67.3	30.4	66.2	31.7		
302 ELN	-8	55.4	21.1	53.6	26.9	52.8	24.1	51.4	25.1	46.9	28.2	40.5	30.3	40.8	31.2
	-4	61.2	22.6	59.1	29.5	58.4	25.6	56.8	26.7	52.0	29.9	46.7	31.9	46.4	32.8
	0	67.0	24.0	64.7	32.1	63.9	27.1	62.2	28.3	57.1	31.6	52.9	33.5	52.1	34.4
	4	71.7	25.5	69.3	27.9	68.5	28.6	66.7	29.9	61.3	33.3	57.6	35.1	56.5	36.4
	5	74.7	25.8	72.1	28.2	71.2	29.0	69.4	30.2	63.8	33.7	60.0	35.5	58.8	36.8
	6	76.0	26.1	73.5	28.5	72.6	29.3	70.7	30.6	65.0	34.1	63.9	35.9	61.7	37.3
	8	78.8	26.9	76.2	77.1	75.3	30.0	73.3	31.3	67.4	35.0	66.3	36.7		
	10	81.5	27.6	78.8	30.0	77.8	30.8	75.9	32.2	69.8	35.8	68.7	37.5		
	13	85.3	28.7	82.4	31.3	81.5	32.0	79.4	33.4	73.2	37.1	72.0	38.7		
352 ELN	-8	70.9	23.7	68.7	30.1	67.5	26.9	65.6	28.0	60.1	31.5	51.9	34.0	52.4	34.9
	-4	78.3	25.3	75.8	33.0	74.6	28.6	72.6	29.8	66.6	33.4	59.8	35.8	59.6	36.7
	0	85.7	26.9	82.9	36.0	81.7	30.3	79.6	31.6	73.1	35.3	67.7	37.6	66.8	38.5
	4	91.8	28.5	88.8	31.2	87.7	32.0	85.4	33.4	78.5	37.3	73.8	39.3	72.4	40.8
	5	95.6	28.9	92.4	31.6	91.1	32.5	88.9	33.8	81.7	37.7	76.8	39.8	75.4	41.2
	6	97.4	29.3	94.2	31.9	93.0	32.8	90.5	34.2	83.2	38.2	81.8	40.2	79.1	41.7
	8	101.0	30.1	97.6	86.2	96.4	33.6	93.9	35.0	86.4	39.2	85.0	41.1		
	10	104.3	30.9	100.9	33.6	99.6	34.5	97.2	36.0	89.4	40.0	88.0	42.0		
	13	109.3	32.1	105.6	35.0	104.4	35.9	101.8	37.4	93.7	41.6	92.2	43.3		

Note : Power input data are given for compressors only.

Cooling Capacities - CLC 402÷602 ELN

CLC MODELS	Evap. Temp. (°C)	AMBIENT AIR TEMPERATURE (°C)													
		25		30		32		35		40		43		46	
		Cool. Cap. (kW)	Power Input (kW)	Cool. Cap. (kW)	Power Input (kW)	Cool. Cap. (kW)	Power Input (kW)	Cool. Cap. (kW)	Power Input (kW)	Cool. Cap. (kW)	Power Input (kW)	Cool. Cap. (kW)	Power Input (kW)	Cool. Cap. (kW)	Power Input (kW)
402 ELN	-8	79.1	28.6	76.5	36.3	75.3	32.4	73.4	33.9	67.1	38.0	57.8	41.1	58.3	42.0
	-4	87.4	30.5	84.4	39.8	83.2	34.5	81.1	36.1	74.3	40.3	66.7	43.2	66.3	44.2
	0	95.6	32.4	92.4	43.4	91.1	36.5	88.8	38.2	81.5	42.6	75.5	45.4	74.4	46.4
	4	102.4	34.4	99.0	37.7	97.8	38.6	95.3	40.4	87.6	45.0	82.3	47.5	80.7	49.2
	5	106.6	34.9	102.9	38.1	101.6	39.2	99.1	40.8	91.1	45.5	85.6	48.0	84.0	49.8
	6	108.5	35.3	105.0	38.5	103.6	39.6	100.9	41.3	92.7	46.1	91.2	48.6	88.1	50.3
	8	112.6	36.3	108.8	104.1	107.5	40.6	104.7	42.3	96.3	47.3	94.7	49.6		
	10	116.3	37.2	112.5	40.6	111.0	41.7	108.3	43.5	99.7	48.3	98.1	50.7		
	13	121.8	38.8	117.7	42.3	116.4	43.3	113.4	45.1	104.5	50.2	102.8	52.3		
502 ELN	-8	97.0	32.4	93.8	41.1	92.2	36.9	89.8	38.4	82.2	43.2	71.0	46.6		
	-4	107.0	34.6	103.6	45.1	101.9	39.2	99.2	40.8	91.0	45.8	81.8	49.0		
	0	117.1	36.8	113.3	49.2	111.6	41.5	108.7	43.2	99.8	48.4	92.6	51.4		
	4	125.4	39.0	121.3	42.7	119.7	43.8	116.7	45.7	107.3	51.0	100.8	53.8		
	5	130.6	39.5	126.1	43.2	124.5	44.4	121.4	46.2	111.6	51.6	104.9	54.4		
	6	133.0	40.0	128.6	43.6	126.9	44.9	123.6	46.8	113.6	52.2	111.8	55.0		
	8	137.9	41.1	133.3	117.9	131.7	46.0	128.2	47.9	118.0	53.5				
	10	142.5	42.2	137.8	46.0	136.0	47.2	132.7	49.2	122.1	54.7				
	13	149.2	43.9	144.1	47.9	142.6	49.0	139.0	51.1	128.0	56.8				
552 ELN	-8	104.3	36.9	101.0	46.8	99.2	41.9	96.7	43.7	88.5	49.1	76.3	52.9		
	-4	115.2	39.4	111.4	51.4	109.7	44.5	106.9	46.5	98.0	52.0	87.9	55.7		
	0	126.1	41.9	121.9	55.9	120.2	47.2	117.1	49.2	107.5	55.0	99.6	58.4		
	4	135.0	44.4	130.6	48.6	128.9	49.8	125.6	52.0	115.5	58.0	108.5	61.2		
	5	140.6	45.0	135.8	49.1	134.0	50.5	130.7	52.6	120.2	58.7	112.9	61.9		
	6	143.1	45.5	138.4	49.7	136.7	51.1	133.1	53.3	122.3	59.4	120.3	62.6		
	8	148.5	46.8	143.5	50.8	141.7	52.3	138.1	54.5	127.0	60.9				
	10	153.4	48.0	148.3	52.3	146.4	53.7	142.9	56.1	131.5	62.3				
	13	160.6	50.0	155.2	54.5	153.5	55.8	149.6	58.2	137.8	64.7				
602 ELN	-8	111.8	41.4	108.1	52.5	106.3	47.0	103.6	49.1	94.8	55.1	81.7	59.3		
	-4	123.4	44.2	119.4	57.6	117.5	49.9	114.5	52.1	104.9	58.4	94.2	62.4		
	0	135.0	47.0	130.6	62.8	128.7	52.9	125.4	55.2	115.1	61.7	106.7	65.5		
	4	144.6	49.8	139.9	54.5	138.1	55.9	134.6	58.4	123.7	65.1	116.2	68.7		
	5	150.6	50.4	145.4	55.1	143.5	56.7	140.0	59.0	128.7	65.8	121.0	69.4		
	6	153.3	51.1	148.3	55.7	146.4	57.3	142.6	59.8	131.0	66.6	128.9	70.2		
	8	159.0	52.5	153.7	57.0	151.8	58.7	147.9	61.2	136.1	68.3				
	10	164.3	53.9	158.9	58.7	156.9	60.2	153.0	62.9	140.8	69.9				
	13	172.1	56.0	166.2	61.2	164.5	62.6	160.3	65.2	147.6	72.5				

Note : Power input data are given for compressors only.

Cooling Capacities - CLC 182 ÷ 352 HT

CLC MODELS	Evap. Temp. (°C)	AMBIENT AIR TEMPERATURE (°C)															
		25		30		32		35		40		43		46		48	
		Cool. Cap. (kW)	Power Input (kW)	Cool. Cap. (kW)	Power Input (kW)	Cool. Cap. (kW)	Power Input (kW)	Cool. Cap. (kW)	Power Input (kW)	Cool. Cap. (kW)	Power Input (kW)	Cool. Cap. (kW)	Power Input (kW)	Cool. Cap. (kW)	Power Input (kW)	Cool. Cap. (kW)	Power Input (kW)
182 HT	-8	35.1	8.5	33.8	10.8	33.3	9.7	32.4	10.0	29.7	11.3	25.6	12.3	25.8	12.5	24.9	12.9
	-4	38.7	9.1	37.4	11.9	36.8	10.3	35.9	10.7	32.9	12.0	29.6	12.9	29.4	13.2	28.4	13.5
	0	42.4	9.7	40.9	13.0	40.3	10.9	39.3	11.3	36.1	12.7	33.5	13.5	33.0	13.8	32.0	14.2
	4	45.4	10.3	43.9	11.2	43.3	11.5	42.2	12.0	38.8	13.4	36.5	14.2	35.8	14.7	34.8	15.1
	5	47.3	10.4	45.6	11.4	45.0	11.7	43.9	12.2	40.4	13.6	38.0	14.3	37.2	14.8	36.2	15.3
	6	48.1	10.5	46.5	11.5	45.9	11.8	44.7	12.3	41.1	13.7	40.4	14.5	39.1	15.0		
	8	49.9	10.8	48.2	31.1	47.7	12.1	46.4	12.6	42.7	14.1	42.0	14.8	40.6	14.2		
	10	51.6	11.1	49.9	12.1	49.2	12.4	48.0	13.0	44.2	14.4	43.5	15.1				
13	54.0	11.6	52.2	12.6	51.6	12.9	50.3	13.5	46.3	15.0	45.6	15.6					
202 HT	-8	46.6	12.4	45.0	15.7	44.3	14.1	43.1	14.8	39.4	16.5	34.0	17.8	34.3	18.2	33.0	18.8
	-4	51.4	13.2	49.7	17.2	49.0	15.0	47.7	15.7	43.7	17.5	39.2	18.7	39.0	19.1	37.7	19.7
	0	56.3	14.0	54.4	18.8	53.6	15.8	52.2	16.6	47.9	18.5	44.4	19.6	43.8	20.1	42.5	20.6
	4	60.3	14.9	58.3	16.3	57.5	16.7	56.1	17.5	51.5	19.5	48.4	20.5	47.5	21.3	46.2	21.9
	5	62.7	15.1	60.6	16.5	59.8	17.0	58.3	17.7	53.6	19.7	50.4	20.8	49.4	21.5	48.0	22.2
	6	63.9	15.3	61.8	16.7	61.0	17.1	59.4	17.9	54.6	19.9	53.7	21.0	51.9	21.8		
	8	66.3	15.7	64.0	45.0	63.3	17.6	61.6	18.3	56.7	20.4	55.7	21.5	53.9	20.6		
	10	68.5	16.1	66.2	17.6	65.3	18.0	63.8	18.8	58.7	20.9	57.7	21.9				
13	71.7	16.8	69.3	18.3	68.5	18.7	66.8	19.5	61.5	21.7	60.5	22.6					
242 HT	-8	55.7	16.3	53.9	20.6	53.2	18.4	51.8	19.2	47.4	21.6	41.0	23.5	41.2	24.1	39.8	24.7
	-4	61.5	17.4	59.6	22.6	58.8	19.6	57.3	20.4	52.5	23.0	47.2	24.7	46.8	25.3	45.4	25.9
	0	67.4	18.5	65.2	24.7	64.4	20.8	62.7	21.7	57.6	24.3	53.4	25.9	52.5	26.5	51.0	27.1
	4	72.2	19.6	69.8	21.4	69.0	22.0	67.3	23.0	61.8	25.7	58.1	27.1	57.0	28.1	55.4	28.9
	5	75.2	19.9	72.7	21.7	71.7	22.3	70.0	23.3	64.4	25.9	60.5	27.4	59.3	28.3	57.7	29.2
	6	76.6	20.1	74.1	22.0	73.2	22.6	71.2	23.5	65.4	26.2	64.4	27.7	62.2	28.7		
	8	79.4	20.7	76.9	59.3	75.9	23.2	73.9	24.1	68.0	26.9	66.8	28.3	64.6	27.2		
	10	82.1	21.2	79.4	23.2	78.4	23.7	76.4	24.8	70.4	27.6	69.2	28.9				
13	86.0	22.1	83.1	24.1	82.1	24.7	80.1	25.8	73.7	28.6	72.5	29.8					
302 HT	-8	63.5	18.3	61.3	23.1	60.3	20.6	58.7	21.6	53.7	24.3	46.3	26.1	46.9	26.8	45.0	27.5
	-4	70.1	19.5	67.7	25.4	66.7	21.9	64.9	22.9	59.5	25.7	53.4	27.4	53.3	28.2	51.4	28.8
	0	76.6	20.7	74.0	27.6	73.0	23.2	71.1	24.3	65.3	27.2	60.5	28.8	59.7	29.6	57.8	30.2
	4	82.1	21.9	79.3	24.0	78.3	24.5	76.3	25.7	70.1	28.7	65.9	30.2	64.7	31.3	62.9	32.3
	5	85.4	22.2	82.5	24.3	81.4	24.9	79.4	25.9	73.0	28.9	68.6	30.5	67.3	31.7	65.4	32.5
	6	87.0	22.5	84.1	24.5	83.1	25.2	80.9	26.3	74.3	29.3	73.1	30.9	70.7	32.0		
	8	90.2	23.0	87.2	66.2	86.2	25.9	83.9	26.9	77.2	30.1	75.9	31.6	73.3	30.3		
	10	93.2	23.7	90.1	25.9	88.9	26.5	86.8	27.6	79.8	30.7	78.6	32.2				
13	97.6	24.6	94.3	26.9	93.3	27.5	90.9	28.7	83.7	31.9	82.4	33.3					
352 HT	-8	74.7	22.3	72.0	28.5	71.0	25.3	69.1	26.4	63.2	29.8	54.4	31.9	54.8	32.9	52.7	33.6
	-4	82.4	23.8	79.5	31.2	78.4	26.9	76.4	28.1	70.0	31.5	62.8	33.6	62.4	34.5	60.3	35.3
	0	90.1	25.3	87.0	33.9	85.9	28.5	83.7	29.7	76.8	33.3	71.1	35.3	70.0	36.2	67.9	37.0
	4	96.5	26.8	93.2	29.4	92.1	30.1	89.7	31.4	82.5	35.1	77.5	37.0	76.0	38.3	73.9	39.5
	5	100.4	27.2	97.0	29.7	95.7	30.6	93.4	31.8	85.8	35.5	80.7	37.4	79.1	38.8	76.9	39.9
	6	102.3	27.5	98.8	30.1	97.6	30.8	95.1	32.2	87.3	35.9	85.9	37.8	83.0	39.3		
	8	106.0	28.3	102.5	81.1	101.2	31.6	98.6	32.9	90.8	36.9	89.2	38.7	86.2	37.2		
	10	109.5	29.0	105.9	31.6	104.6	32.5	102.1	33.9	93.9	37.6	92.4	39.6				
13	114.7	30.2	110.9	32.9	109.6	33.7	106.8	35.1	98.4	39.1	96.9	40.8					

Note : Power input data are given for compressors only.

Cooling Capacities - CLC 402 ÷ 602 HT

CLC MODELS	Evap. Temp. (°C)	AMBIENT AIR TEMPERATURE (°C)															
		25		30		32		35		40		43		46		48	
		Cool. Cap. (kW)	Power Input (kW)	Cool. Cap. (kW)	Power Input (kW)	Cool. Cap. (kW)	Power Input (kW)	Cool. Cap. (kW)	Power Input (kW)	Cool. Cap. (kW)	Power Input (kW)	Cool. Cap. (kW)	Power Input (kW)	Cool. Cap. (kW)	Power Input (kW)	Cool. Cap. (kW)	Power Input (kW)
402 HT	-8	87.2	25.3	84.4	31.6	82.9	28.5	80.9	29.7	73.9	33.5	63.8	35.9	64.4	36.8	61.9	37.8
	-4	96.3	26.9	93.1	34.8	91.6	30.3	89.4	31.6	81.8	35.5	73.5	37.8	73.2	38.8	70.7	39.8
	0	105.3	28.6	101.8	38.0	100.4	32.1	97.9	33.5	89.8	37.5	83.2	39.7	82.0	40.7	79.6	41.7
	4	112.8	30.3	109.1	33.0	107.7	33.9	104.9	35.4	96.4	39.5	90.6	41.6	89.0	43.2	86.5	44.4
	5	117.5	30.7	113.4	33.4	112.0	34.4	109.2	35.8	100.4	40.0	94.4	42.1	92.6	43.7	90.0	44.9
	6	119.6	31.0	115.6	33.8	114.2	34.8	111.2	36.3	102.2	40.4	100.5	42.6	97.1	44.2		
	8	124.0	31.8	119.9	31.4	118.4	35.6	115.3	37.2	106.1	41.5	104.3	43.6	100.8	41.8		
	10	128.2	32.7	123.9	35.6	122.4	36.6	119.3	38.2	109.8	42.4	108.0	44.5				
	13	134.2	34.0	129.6	37.2	128.3	38.0	124.9	39.6	115.1	44.0	113.2	45.9				
502 HT	-8	100.5	31.0	97.3	39.4	95.6	35.4	93.1	36.9	85.2	41.5	73.7	44.6	74.1	45.5		
	-4	111.0	33.1	107.3	43.2	105.7	37.6	102.9	39.2	94.3	43.9	84.8	46.9	84.3	47.9		
	0	121.4	35.2	117.4	47.1	115.7	39.8	112.7	41.4	103.5	46.4	96.0	49.2	94.5	50.3		
	4	130.0	37.4	125.8	40.9	124.1	42.0	121.0	43.8	111.2	48.9	104.5	51.5	102.5	53.4		
	5	135.4	37.8	130.7	41.4	129.1	42.5	125.9	44.3	115.7	49.4	108.8	52.1	106.7	53.9		
	6	137.9	38.3	133.3	41.8	131.6	43.0	128.1	44.8	117.8	50.0	115.9	52.7	112.0	54.6		
	8	143.0	39.4	138.2	112.9	136.5	44.1	132.9	45.9	122.3	51.2	120.3	53.8				
	10	147.7	40.4	142.9	44.1	141.0	45.2	137.6	47.1	126.6	52.4	124.5	55.0				
	13	154.7	42.1	149.4	45.9	147.8	46.9	144.1	48.9	132.7	54.4	130.5	56.7				
552 HT	-8	108.2	35.4	104.7	44.8	102.9	40.1	100.2	41.9	91.7	47.0	79.1	50.7	79.8	51.9		
	-4	119.4	37.7	115.5	49.2	113.7	42.6	110.8	44.5	101.6	49.9	91.2	53.3	90.7	54.6		
	0	130.7	40.1	126.4	53.6	124.6	45.2	121.4	47.1	111.4	52.7	103.3	56.0	101.7	57.3		
	4	140.0	42.5	135.4	46.5	133.7	47.7	130.2	49.9	119.7	55.6	112.5	58.6	110.4	60.8		
	5	145.8	43.1	140.8	47.1	138.9	48.4	135.5	50.4	124.6	56.2	117.1	59.3	114.9	61.4		
	6	148.4	43.6	143.5	47.6	141.7	48.9	138.0	51.0	126.8	56.9	124.7	60.0	120.5	62.2		
	8	153.9	44.8	148.8	48.5	146.9	50.1	143.1	52.2	131.7	58.4	129.5	61.3				
	10	159.1	46.0	153.8	50.1	151.8	51.4	148.1	53.7	136.3	59.7	134.1	62.6				
	13	166.6	47.9	160.9	52.2	159.2	53.4	155.1	55.7	142.9	62.0	140.6	64.6				
602 HT	-8	115.9	39.7	112.1	50.2	110.2	45.0	107.4	47.0	98.2	52.7	84.7	56.8	85.4	58.2		
	-4	127.9	42.3	123.8	55.2	121.8	47.8	118.7	49.9	108.8	55.9	97.7	59.8	97.2	61.3		
	0	140.0	45.0	135.4	60.1	133.4	50.7	130.0	52.9	119.4	59.1	110.6	62.8	108.9	64.3		
	4	149.9	47.7	145.0	52.2	143.2	53.5	139.5	55.9	128.2	62.3	120.5	65.8	118.2	68.2		
	5	156.1	48.3	150.8	52.8	148.8	54.3	145.1	56.5	133.4	63.1	125.4	66.5	123.0	68.9		
	6	159.0	48.9	153.7	53.4	151.8	54.9	147.8	57.3	135.8	63.8	133.6	67.3	129.1	69.7		
	8	164.9	50.3	159.4	54.4	157.4	56.2	153.3	58.6	141.1	65.5	138.7	68.7				
	10	170.4	51.6	164.7	56.2	162.6	57.7	158.7	60.2	146.0	67.0	143.6	70.2				
	13	178.4	53.7	172.3	58.6	170.5	59.9	166.1	62.5	153.0	69.5	150.6	72.5				

Note : Power input data are given for compressors only.

Dimensions

Models CLC 182 to 302 STD/LN/ELN/HPF/HT

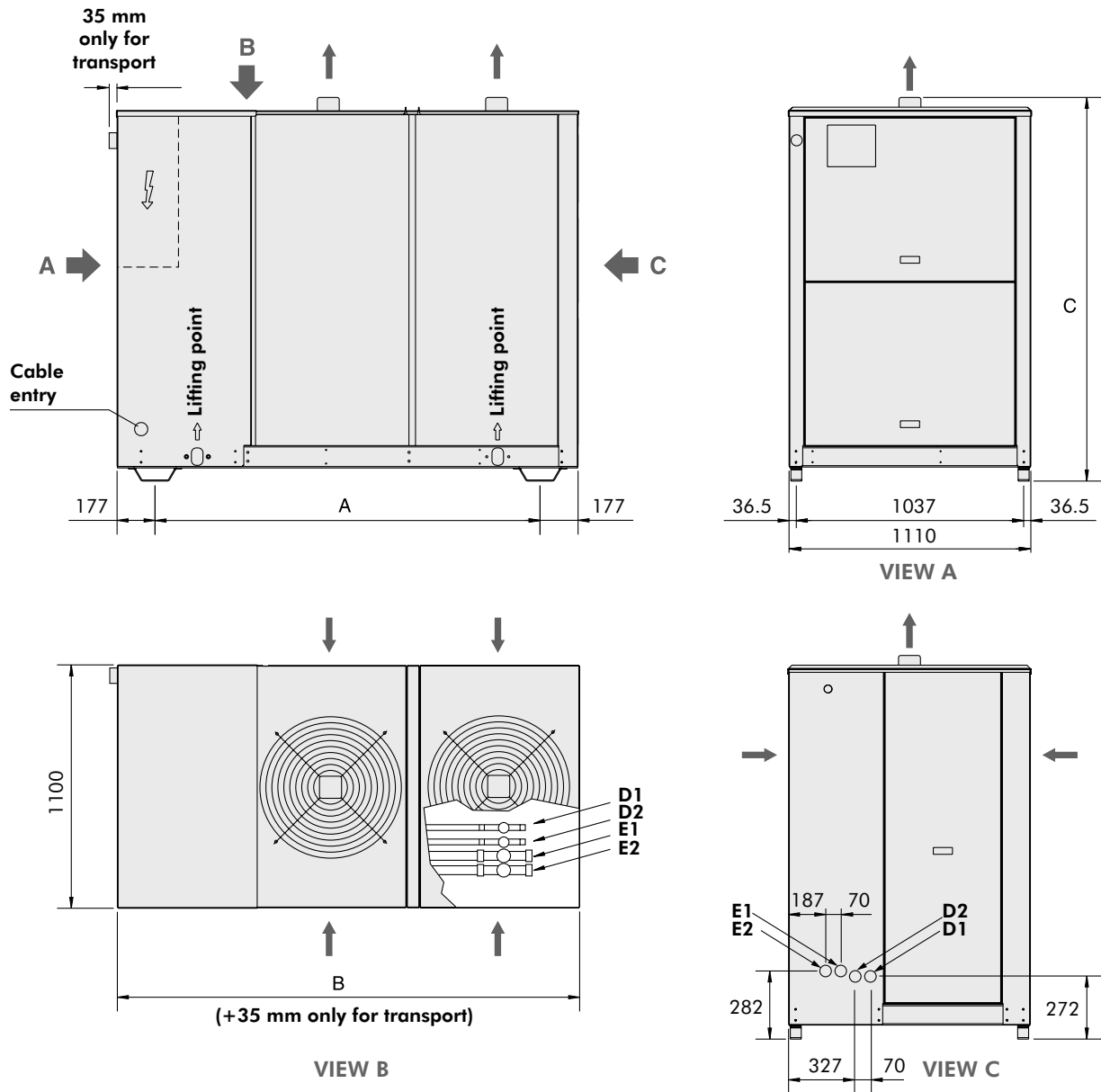

D1, D2 : Liquid lines.
E1, E2 : Suction lines.

CLC	D1-D2	E1-E2
182-202	1/2"	7/8"
242-302	5/8"	1"5/8"

Models	Versions	Dimensions A (mm)	Dimensions B (mm)	Dimensions C (mm)	Number of fans
CLC 182	Standard	1756	2110	1750	2
	LN/HPF/HT	1756	2110	1850	2
	ELN	1756	2110	1850	2
CLC 202	Standard	1756	2110	1750	2
	LN/HPF/HT	1756	2110	1850	2
	ELN	1756	2110	1850	2
CLC 242	Standard	1756	2110	1750	2
	LN/HPF/HT	1756	2110	1850	2
	ELN	1756	2110	1850	2
CLC 302	Standard	1756	2110	1750	2
	LN/HPF/HT	1756	2110	1850	2
	ELN	1756	2110	1850	2

Dimensions (continued)

Models CLC 352 to 602 STD/LN/ELN/HPF/HT

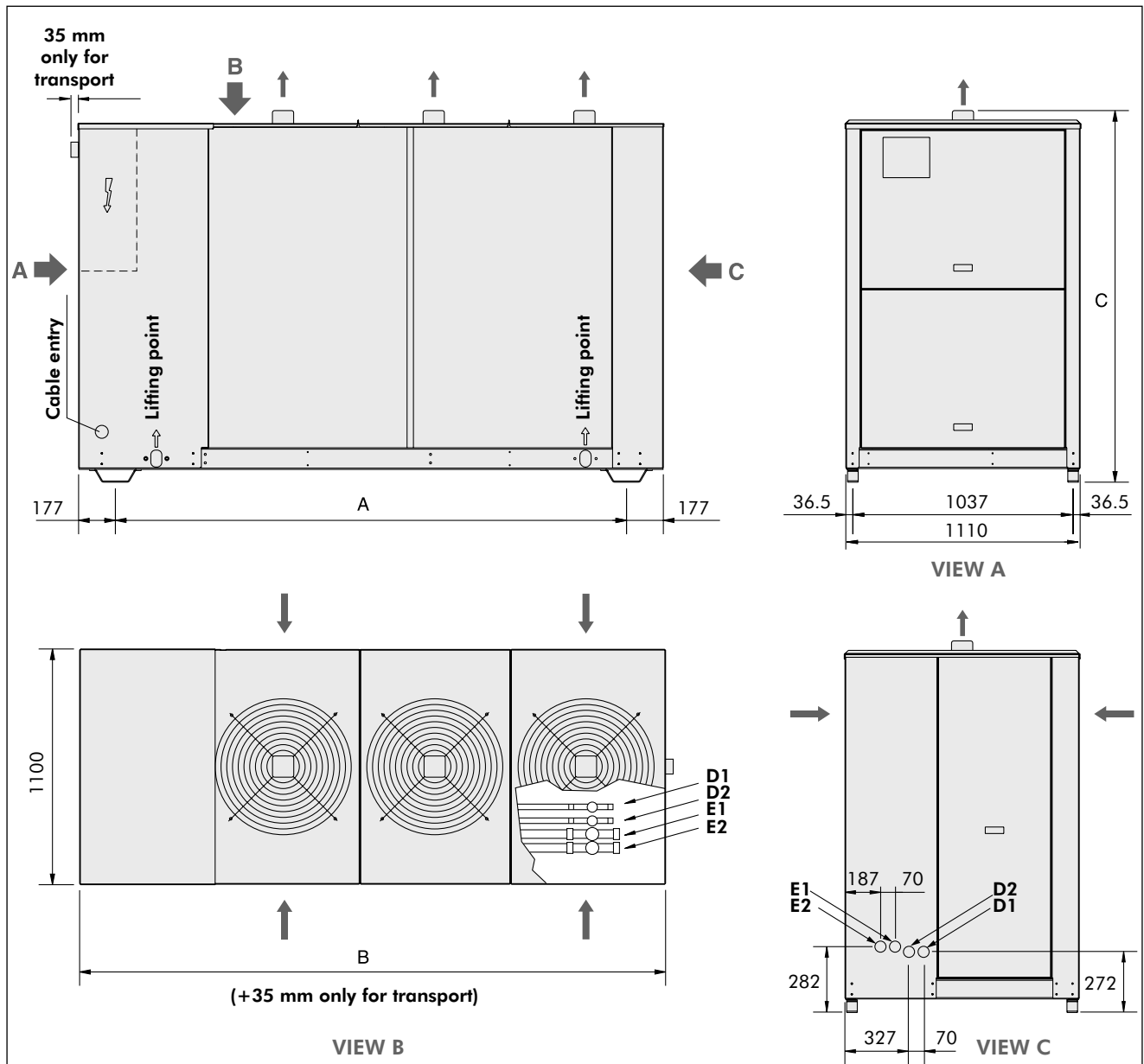

D1, D2 : Liquid lines.
E1, E2 : Suction lines.

CLC	D1-D2	E1-E2
352 to 602	5/8"	1"5/8

Models	Versions	Dimensions A (mm)	Dimensions B (mm)	Dimensions C (mm)	Number of fans
CLC 352	Standard	2406	2760	1750	3
	LN/HPF/HT	2406	2760	1850	3
	ELN	2406	2760	1850	3
CLC 402	Standard	2406	2760	1750	3
	LN/HPF/HT	2406	2760	1850	3
	ELN	2406	2760	1850	3
CLC 502	Standard	2756	3110	1750	3
	LN/HPF/HT	2756	3110	1850	3
	ELN	2756	3110	1850	3
CLC 552	Standard	2756	3110	1750	3
	LN/HPF/HT	2756	3110	1850	3
	ELN	2756	3110	1850	3
CLC 602	Standard	2756	3110	1750	3
	LN/HPF/HT	2756	3110	1850	3
	ELN	2756	3110	1850	3

Dimensions (continued)

Models CLC 352 & 402 SIF

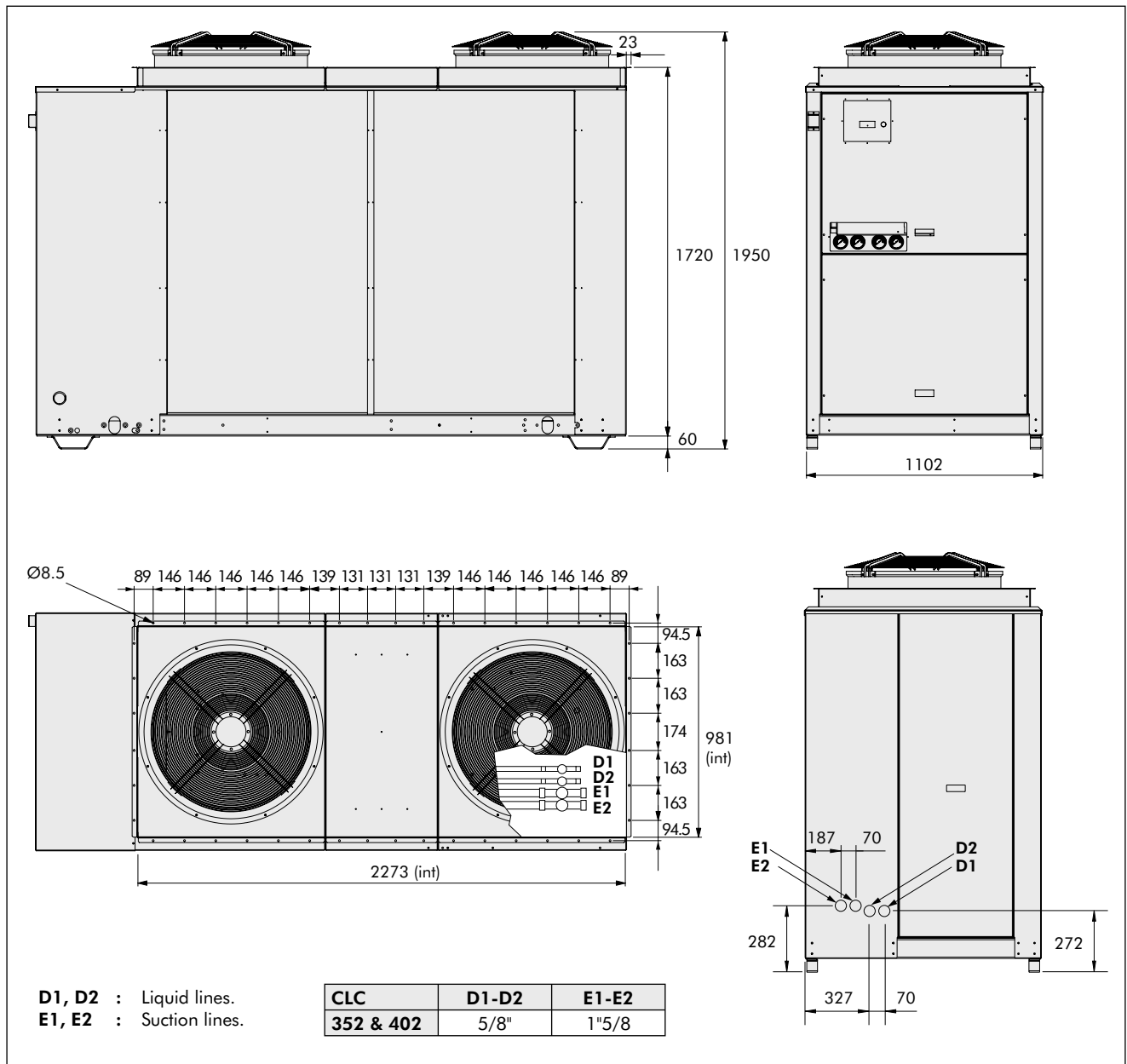

Dimensions (continued)

Models CLC 502 to 602 SIF

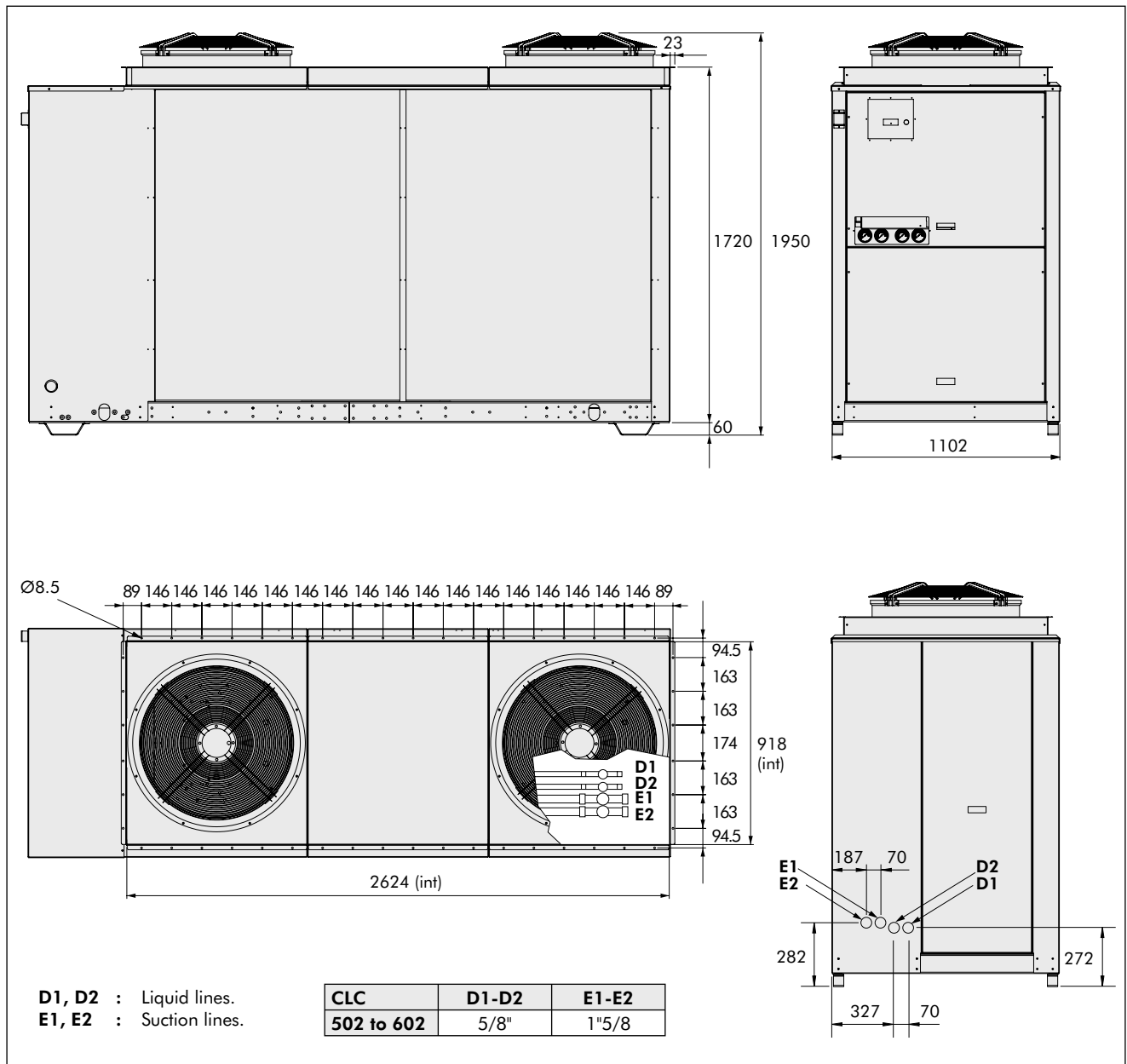

Space Requirements

Single unit applications

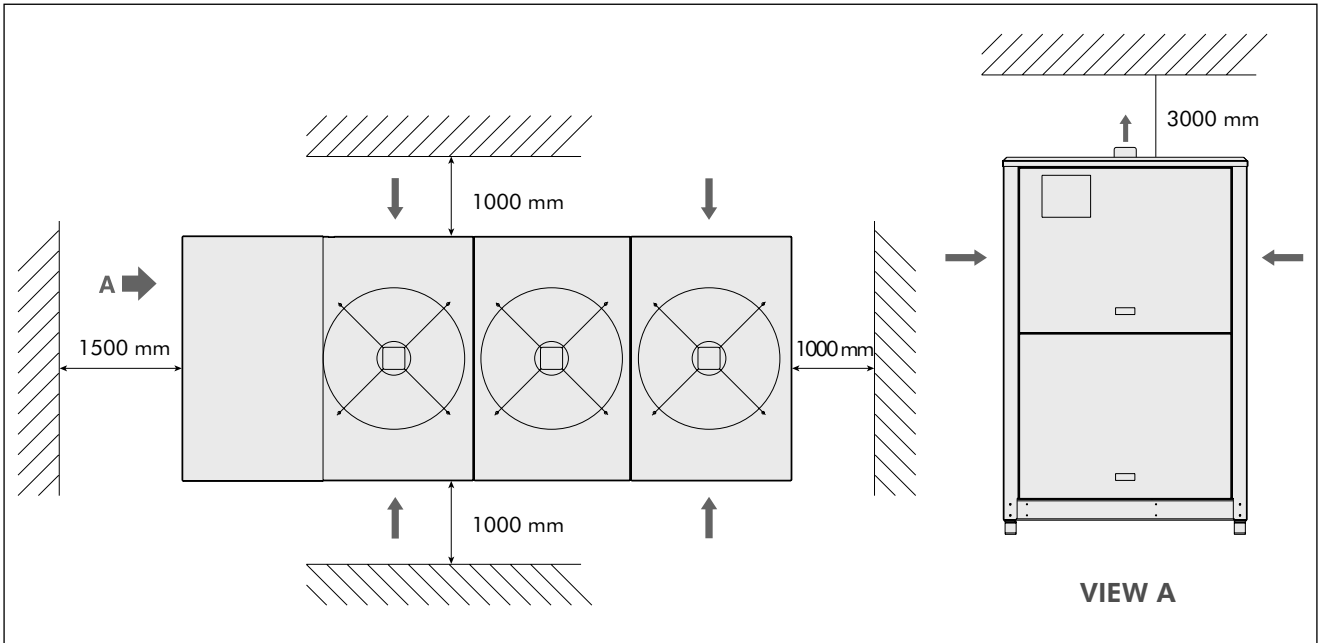

Multi units applications

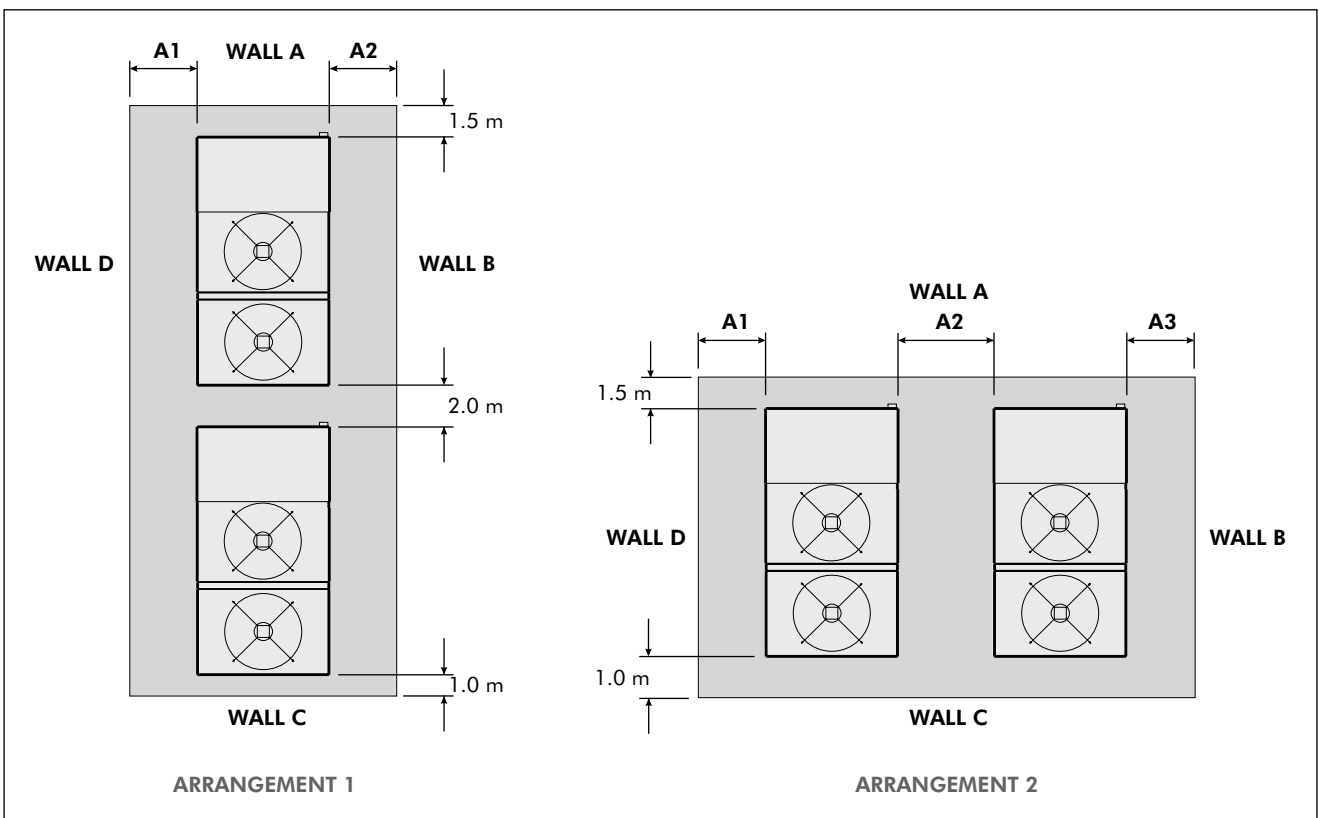

	LOUVRED A & C SOLID B & D			SOLID A & B SOLID C & D			SOLID A & C LOUVRED B & D			LOUVRED A & B SOLID C & D			LOUVRED A & D SOLID B & C		
	A1	A2	A3	A1	A2	A3	A1	A2	A3	A1	A2	A3	A1	A2	A3
ARRANGEMENT 1	1.0	1.0		1.0	1.0		0.8	0.8		1.0	0.8		0.8	1.0	
ARRANGEMENT 2	1.0	1.5	1.0	1.0	2.0	1.0	0.8	2.0	0.8	1.0	1.5	0.8	0.8	1.5	1.0

Note : No more than one wall can be higher than the unit.

The area enclosed by the wall must be kept clear of all obstructions that would impede air flow to the unit.

Notes

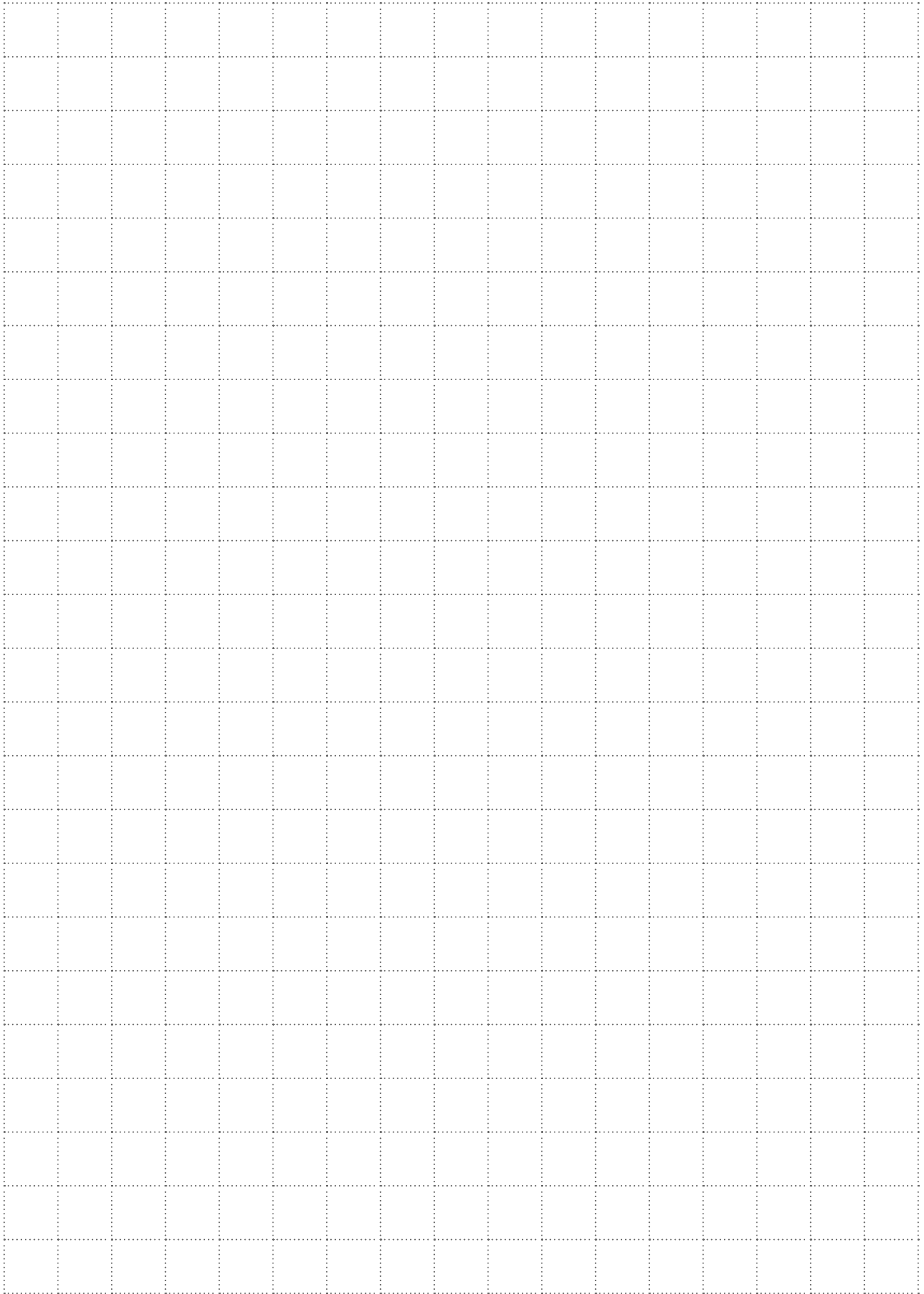

Notes

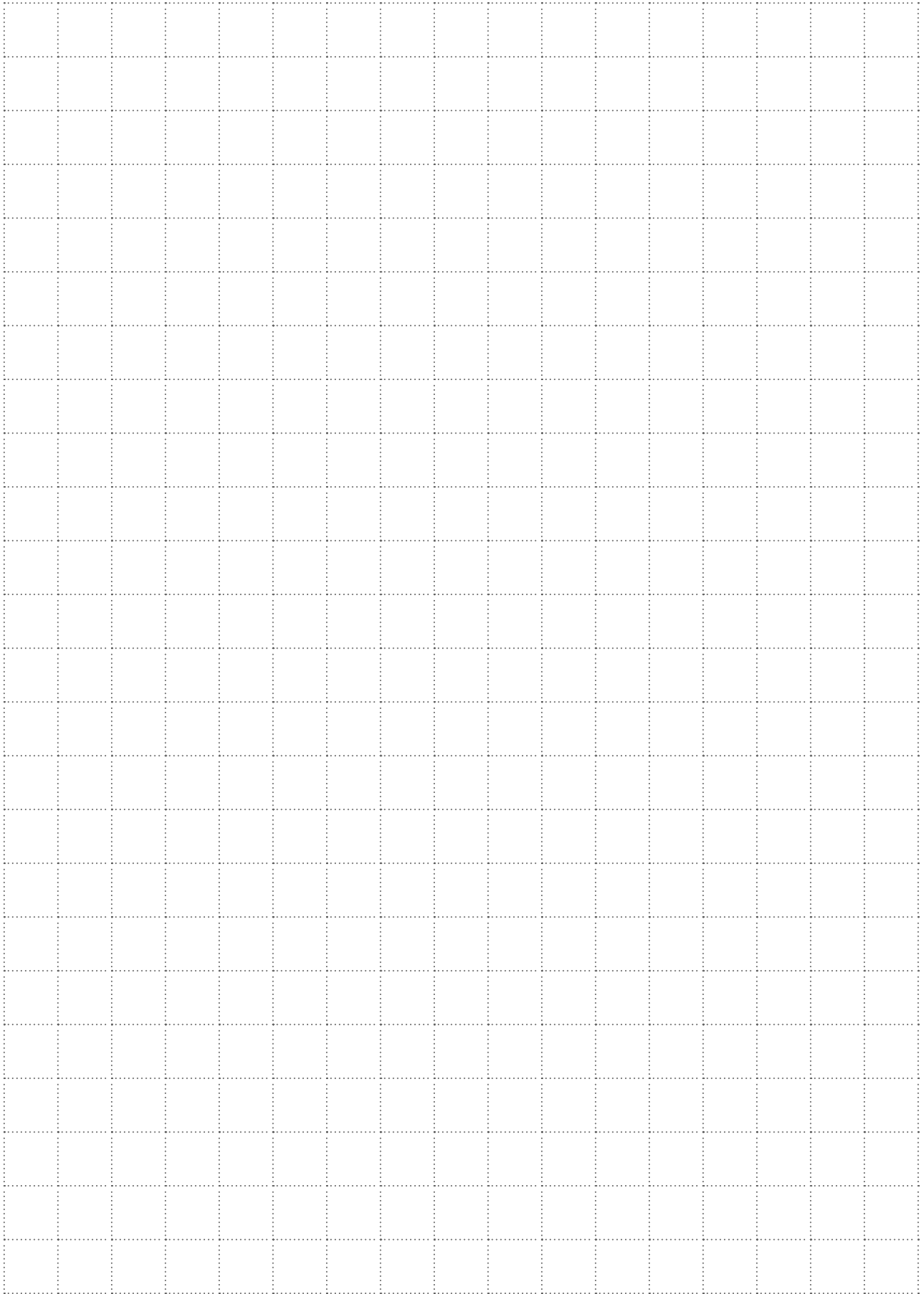

Airwell

As part of our ongoing product improvement programme, our products are subject to change without prior notice. Non contractual photos.



CAC Export Department
42 cours Jean-Jaurès
17800 Pons - France
Tel. : +33 (0)5 46 92 33 33 - Fax : +33 (0)5 46 91 26 44

Your distributor :