

► Air-to-Water Reverse Cycle Heat Pumps

Aqu@Logic AQH 20 to 130



20 to 131 kW



23 to 141 kW



Technical Brochure

TM AQH-A.2GB

Date : March 2004

Supersedes : TM AQH-A.1GB/05.03

Airwell

Why choose ILTC technology ?

The new range of **Aqu@Logic** air-to-water reverse cycle heat pumps comprises **14 models** covering a nominal cooling capacity range from 20 to 131 kW and a nominal heating capacity range from 23 to 141 kW.

Aqu@Logic represents a new generation of innovative heat pumps, integrating components using the very latest technological advances.

These components provide **Aqu@Logic** heat pumps with considerable advantages in terms of compact design and improved efficiency and reliability.

All **Aqu@Logic** heat pumps are equipped with **ILTC (Intelligent Liquid Technology Chiller)** control providing optimised control across the unit's entire operating range.

As standard equipment, each unit has two compressors, fitted in tandem, for adapting to partial system loads.

Pressure and temperature sensors provide data to the electronic control system for taking account of the prevailing operating parameters in order to optimise system performance.

This intelligent control system enables water temperature to be maintained within the required range, whilst only using a small volume of water (**2.5 l/kW**) and thus eliminating, for the majority of comfort air conditioning applications, the need for a buffer water tank.

Features and benefits

A maximum of technology

The new generation of **Aqu@Logic** air-to-water reverse cycle heat pumps integrates high technology components :

- Scroll compressors.
- Brazed stainless steel plate heat exchangers.
- High efficiency axial fans with external rotors.
- Microprocessor based **ILTC control**.
- HFC 407C refrigerant fluid.

Quick and easy installation at minimal cost

- Compact units taking up the strict minimum of ground surface area, for easy installation.
- "Plug and Play" design with an integrated hydraulic module for minimising installation costs.
- Perfect accessibility : easy access to all components, thanks to panels removable by a quarter turn key or screw, thus significantly reducing unit maintenance times.

Increased performance

- Optimal efficiency, thanks to the use of Scroll compressors with a high Coefficient Of Performance (COP), fitted in tandem on all models in the range.
- Guaranteed for operating at outdoor temperatures between -10 °C and +46 °C inclusive, thanks to the automatic condensing pressure management system supplied as standard equipment on all models in the range.

- Silent running, thanks to the dual-speed fan, selected for being one of the quietest fans currently available on the market, and thanks to the use of particularly quiet, low vibration, Scroll compressors.

Built to last

- **ILTC control** automatically manages the balancing of the compressors' running times, thus enabling their service life to be extended.
- Sealed refrigerant circuit : all the refrigerant components and pipe work are brazed, thus eliminating any risks of leakage. Pressure transducers replace the HP and LP pressostats, along with their capillary tubes (principal source of leaks).

Energy savings all year round

Thanks to **ILTC control** :

- Providing intelligent management of the compressors' running times.
- In the majority of cases, obviating the need for a buffer tank for comfort air conditioning applications.
- Continuously monitoring and managing all the machine's operating parameters.

Optimized defrost

The management of the defrost cycles is assured by the ILTC control, which decides in relation to the unit operating parameters and through temperature and pressure sensors, the start and the stop of the unit defrost.

General specifications

Cabinet and structure

- Made of galvanised steel panels coated with oven-baked epoxy paint. Colour : RAL 9001.
- For access to all components, the panels are removable by just releasing quarter turn locks or screws.

Compressors

- Hermetically sealed, high output Scroll type compressors with a high Coefficient Of Performance (COP).
- All models in the range equipped with compressors fitted in tandem for reducing both starting current draw and power absorbed under partial load conditions.

- Excellent acoustic performance with extremely quiet operation and minimal vibration.
- Robust and reliable Scroll compressor technology :

Few moving parts (only 3), high tolerance to liquid pressure shocks, low starting torque, protection against excessive discharge temperatures.
- Compressor motor cooled by intake gasses and equipped with automatic reset internal high temperature protection.
- All compressors are mounted on anti-vibration pads in order to minimise noise and vibration transmission. Furthermore, they are supplied with soundproof jackets.

General specifications (continued)

Evaporator

- Direct expansion type, made of brazed stainless steel plates.
- The evaporator is surrounded by an electrical heating resistance and insulated with cellular polyurethane foam to provide anti-freeze protection down to an ambient temperature of - 20 °C.

Air condenser

- Comprising a heat exchanger coil equipped with aluminium fins mechanically crimped on to copper tubes.

Fan motor assembly

- Helicoidal type fans with direct drive by a dual speed motor (Protection Index : IP 54), equipped with automatic reset internal high temperature protection.
- Two 610 mm diameter horizontal flow fans on models 20 to 35, one 800 mm diameter vertical flow fan on models 40 to 80 and two 800 mm diameter vertical flow fans on models 90 to 130. Each fan is equipped with a fan blade protection grille.

Refrigerant circuit

The refrigerant circuit comprises all the required components such as filter-dryer, sight glass with moisture indicator, 4-way reverse cycle valve and thermostatic expansion valve. It also comprises high and low pressure sensors, as well as sensors for inlet and outlet water temperatures and a discharge temperature sensor.

To facilitate maintenance operations, the low and high pressure sections of the refrigerant circuit are equipped with pressure tapping points.

All the refrigerant components and pipe work are brazed, thus eliminating any risks of leakage and ensuring total, long lasting circuit tightness.

Pressure transducers replace the HP (High Pressure) and LP (Low Pressure) pressostats, along with their capillary tubes (principal source of leaks).

The refrigerant circuit is optimised to operate with HFC 407C refrigerant fluid.

Electrical panel

Access to the electrical panel is possible after having taken off the panels, removable by just releasing quarter turn locks or screws. The electrical panel of models 90 to 130 rotates to allow an easy access for inspection inside the unit.

On models 20 to 35, the following equipment is mounted on the power circuit side of the electrical panel : a power supply connection terminal block - 400 V / 3 Ph / 50 Hz + Neutral, a main switch, contactors and thermal relays for the compressors and the hydraulic pump (if fitted). On the control circuit side of the panel, the ILTC control electronic circuit board with its 230 V single phase power supply is mounted.

On models 40 to 130, the following equipment is mounted on the power circuit side of the electrical panel : a power supply connection terminal block - 400 V / 3 Ph / 50 Hz + Neutral (models 40 to 80) or 400 V / 3 Ph / 50 Hz (models 90 to 130), a main switch, a main terminal block, a distribution terminal block, the compressors contactors, the thermal relays and contactors for the fans, and the hydraulic pump (if fitted). On the control circuit side of the panel, the ILTC control electronic circuit board with its 230 V single phase power supply is mounted.

Integrated hydraulic module

An integrated hydraulic module is available for all **Aqu@Logic** air cooled water chillers, offering savings in installation times and reducing installation costs. Each hydraulic module comprises the following components :

On models 20 to 35 : Automatic air bleed valve, differential pressostat, drain cock, expansion tank, safety valve, pressure gauge, hydraulic pump and water filter (supplied as a kit - not fitted).

On models 40 to 130 : Automatic air bleed valve, water flow adjustment valve, water flow switch, drain cock, expansion tank, safety valve, pressure gauge, hydraulic pump and fitted water filter.

As standard, all pumps produce available pressure higher than 100 kPa. A pump producing available pressure higher than 150 kPa can be supplied on request.

Other standard equipment :

Anti-vibration pads kit : The 20 to 130 models are supplied with rubber anti-vibration pads as standard, to be fitted on site by the installer.

Water flow switch or differential pressostat : For **Aqu@Logic** units without an integrated hydraulic module, a factory-fitted differential pressostat (for models 20 to 35) and a field-installed paddle type water flow switch (for models 40 to 130) are supplied as standard.

Water filter : Supplied loose.

Coil protection grilles : **Aqu@Logic** units are supplied with heat exchanger coil protection grilles as standard.

Accessories and options :

Anti-vibration pads kit : For models 40 to 130. Visible spring anti-vibration pads for the unit and the ground mounting holes. For on site fitting by the installer.

Condenser coil protective coating :

- aluminium fins with hydrophilic coating,
- aluminium fins with polyurethane coating.

High pressure fans : For models 40 to 120 with ductable fans providing external static pressure of 80 Pa (models 40 to 60) and 100 Pa (models 70 to 120).

400 V / 230 V transformer : For models 40 to 80 with electrical supply without neutral.

Buffer tank kit : For air conditioning applications where it is not possible to comply with the water volume ratio of 2.5 l / kW. This kit comprises a factory-fitted module, mounted under the unit, and supplied with the external hydraulic pipe work to be fitted on site. The hydraulic module is fully encased in galvanised steel panels, painted the same colour as the unit, and comprises a buffer tank, fully insulated with 30 kg / m³ density cellular polyurethane foam. As standard, the buffer tank is equipped with anti-freeze protection in the form of an immersion heater.

Remote control terminal : Hard-wired control enabling the unit's Start / Stop functions to be controlled remotely.

Phase monitor : Factory-fitted option enabling the compressor's rotational direction to be checked and to stop the unit if the minimum voltage threshold is reached.

Low ambient kit (-18 °C) : Factory-fitted option available for models 40 to 130.

Chiller sequencer : Supplied loose, it allows a control up to 4 units.

HP and LP manometers : Supplied loose.

Water isolating valves : Supplied loose.

Packaging : Sea worth or wooden crate.

ILTC control system

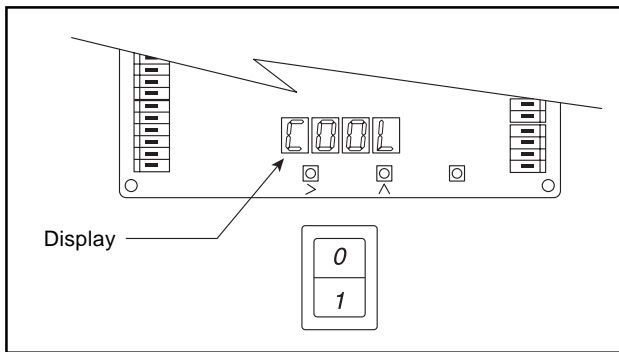

The ILTC control system is an intelligent digital control system designed especially for optimising the operation of **Aqu@Logic** units and maintaining conditions of maximum comfort.

Before each start-up, the ILTC control system runs through a complete machine checklist. It continuously monitors and manages all the machine's operating parameters and safety devices. It precisely manages the running of the compressors and fans in order to optimise energy consumption. It also controls the operation of the water circulation pump.

User interface :

The ILTC control system has an easy-to-use user interface comprising a 4 character, 7 segment red colour LED display, 3 keys below the display for access to the different menus : the right key is reserved for the TEST mode, the centre key for scrolling up and down the menus, and the left key for selecting a parameter and displaying its value.

Six main menus are available for accessing all the machine's controls :

- Parameters.
- Temperature sensors and pressure transducers.
- Active safety alarms.
- Compressors' operating times.
- Safety alarms history (last 10 alarms).
- Machine operating status.

Using these 6 menus enables a machine status diagnosis to be performed as well as checking all the **Aqu@Logic** unit's parameter settings.

ILTC control system description

- Intelligent regulation with return water temperature control and outlet water temperature measurement.
- The selection and operating time duration of each compressor is automatically managed by the ILTC control system, with the possibility of balancing the compressors' operating times. When they are operating, the compressors are monitored constantly to improve their operating cycle and to avoid any excessive cycling. Thus, these **Aqu@Logic** units can operate in complete safety with a low volume of water in the installation, enabling the buffer tank to be dispensed with in the majority of comfort air conditioning applications.
- The ILTC control system is intelligent, i.e. it continuously adapts to changes in the installation's thermal load by optimising running times with the selection of one or both compressors, in relation to actual demand.

- Condensing pressure control is included as standard, thus enabling all **Aqu@Logic** units to operate between - 10 °C and + 46 °C. Condensing pressure control is provided by an algorithm, automatically managing the fan speeds operation. In partial load or low ambient outdoor temperature conditions, the fan is switched automatically to low speed running, offering a significant reduction in noise levels.

- As standard, the ILTC control system offers the possibility of selecting a "Night-time running mode" function.
- Water pump control with 2 possible operating modes: Continuous operation in ON / OFF mode or operating only in ON mode.

When the "**Night-time Running**" mode is activated, four operating modes are available :

1st mode : Selected to change the set temperature for energy savings when the building is unoccupied.

2nd mode : Selected to enable the set temperature to be lowered.

3rd mode : Selected to change the set condensing pressure values, to force the fan to run at low speed and to obtain silent running during the night.

4th mode : Selected for applying a combination of modes 1 and 3.

- In addition, as a standard feature, the ILTC control system offers the possibility of automatically compensating the set temperature value in relation to changes in the outdoor air temperature.
- Automatic switching of cooling or heating mode in relation to the two thresholds of external temperature configurable by the user.

Safety

The system measures changes in parameters (temperatures, pressures,...) and reacts to keep the compressor within its operating range.

If, despite everything, a parameter exceeds its limit, a warning message is generated and the machine is shut down.

The following faults cause the machine to shut down :

- Suction pressure too low.
- Discharge pressure too high.
- Outlet water temperature below authorised limits.
- Discharge temperature too high.
- Compressor(s), fan(s), water pump overload.
- Compressor direction of rotation reversed.
- Temperature sensors and pressure transducers fault.
- Evaporator anti-freeze protection.

The ILTC control system has **33 alarm codes** enabling the origin of breakdowns to be determined.

The following safety devices protect the units :

- Water flow switch or differential pressostat.
- Fan high speed and low speed thermal relays.
- N° 1 and N° 2 compressor internal thermal protection.
- Hydraulic pump thermal relay.
- HP safety pressostat.

Remote unit management

The system enables the following functions to be operated, by means of dry contacts :

- Remote ON / OFF switch.
- Remote Day / Night running mode switch.
- Loadshedding mode.
- Remote alarm reading.
- Inversion of cooling or heating operating mode.

Refrigerant flow diagrams

Models 20 to 80

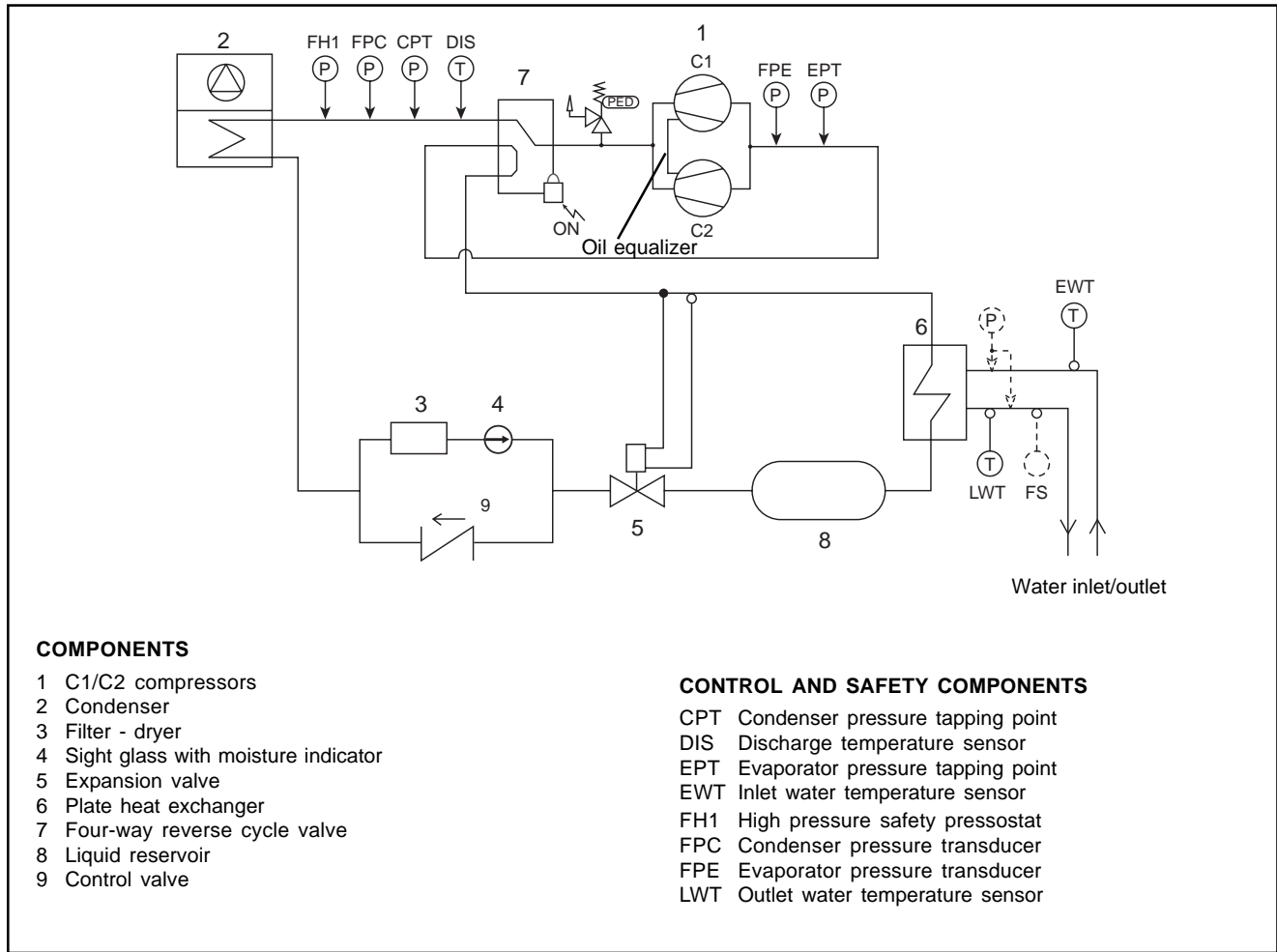

Cooling mode

Low pressure liquid refrigerant enters the refrigerant to water heat exchanger and is evaporated and superheated by the heat energy absorbed from the chilled water passing through the heat exchanger. Low pressure vapour passes through the four way valve before entering the compressor where pressure and superheat are increased. The superheated refrigerant vapour again passes through the four way valve and enters the ambient coil. Heat is rejected via the ambient coil and fans. The fully condensed and subcooled liquid refrigerant then enters the expansion valve where pressure reduction and further cooling takes place before returning to the heat exchanger.

Heating mode

Liquid refrigerant enters the ambient coil and is fully evaporated and superheated by the energy absorbed from the ambient air. Low pressure superheated refrigerant vapour passes through the four way valve and enters the compressor, where pressure and superheat are increased. High pressure superheated refrigerant vapour again passes through the four way valve and enters the refrigerant to water heat exchanger where heat is rejected to the water circulating through the exchanger. The high pressure liquid refrigerant, leaving the heat exchanger, enters the thermostatic expansion valves where the refrigerant pressure is reduced and subsequently cooled before returning to the ambient coil. When ice builds up on the ambient coils defrost is initiated by operating the machine in cooling mode.

Refrigerant flow diagrams (continued)

Models 90 to 130

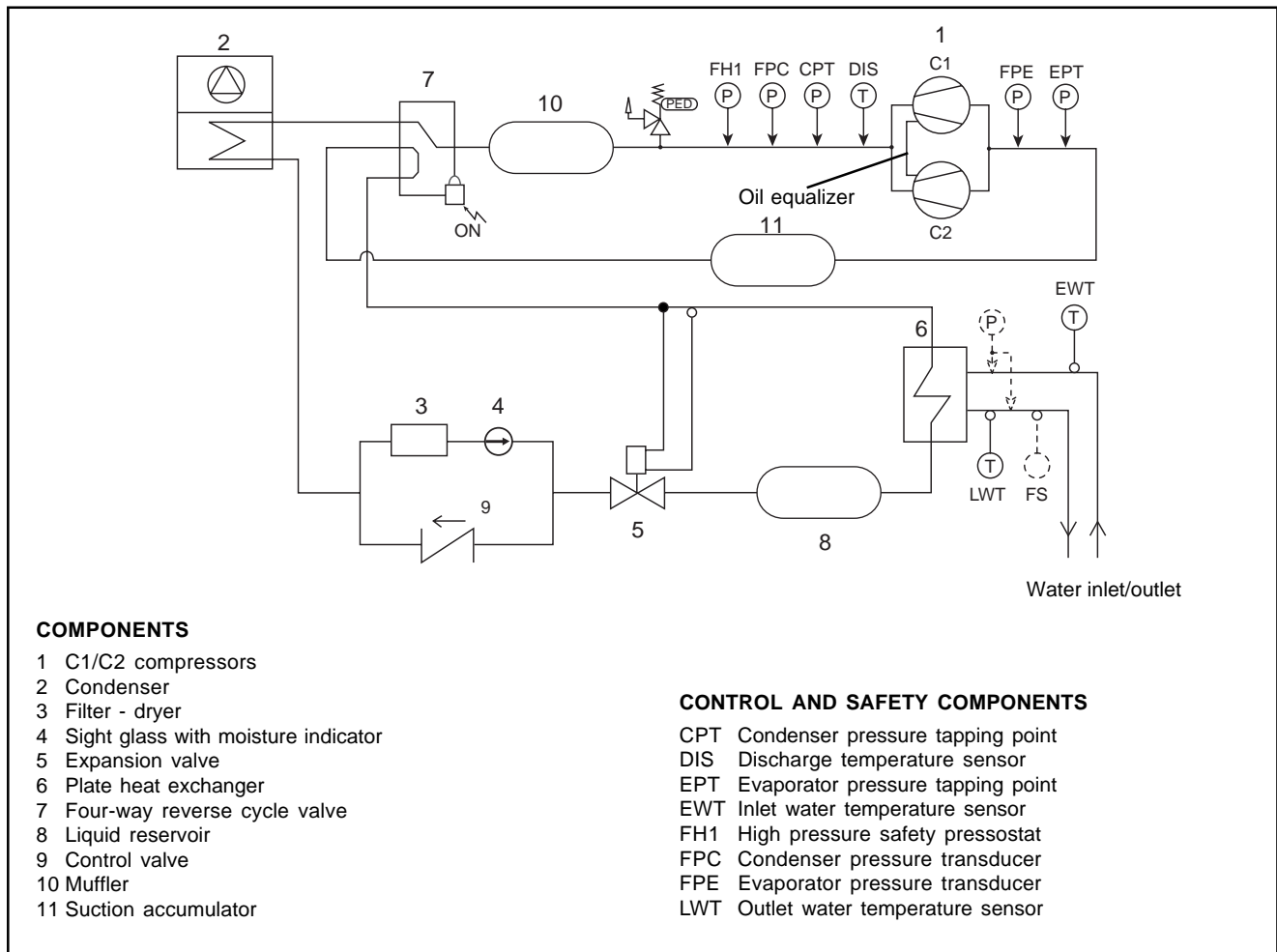

Cooling mode

Low pressure liquid refrigerant enters the refrigerant to water heat exchanger and is evaporated and superheated by the heat energy absorbed from the chilled water passing through the heat exchanger. Low pressure vapour passes through the four way valve before entering the compressor where pressure and superheat are increased. The superheated refrigerant vapour again passes through the four way valve and enters the ambient coil. Heat is rejected via the ambient coil and fans. The fully condensed and subcooled liquid refrigerant then enters the expansion valve where pressure reduction and further cooling takes place before returning to the heat exchanger.

Heating mode

Liquid refrigerant enters the ambient coil and is fully evaporated and superheated by the energy absorbed from the ambient air. Low pressure superheated refrigerant vapour passes through the four way valve and enters the compressor, where pressure and superheat are increased. High pressure superheated refrigerant vapour again passes through the four way valve and enters the refrigerant to water heat exchanger where heat is rejected to the water circulating through the exchanger. The high pressure liquid refrigerant, leaving the heat exchanger, enters the thermostatic expansion valves where the refrigerant pressure is reduced and subsequently cooled before returning to the ambient coil. When ice builds up on the ambient coils defrost is initiated by operating the machine in cooling mode.

Selection guide

The following information is required for selecting the appropriate model :

1. Required cooling capacity in kW.
2. Chilled water inlet / outlet temperatures.
3. Outdoor air temperature.
4. Altitude (in metres) above sea level.

N.B. : the cooling capacity is determined by the following formula :

$$\text{Cooling capacity (kW)} = [\text{Water flow (l/h)} \times \text{Delta T (K)}] / 860$$

Selection example

Data :

- Required cooling capacity : 21 kW.

- Outlet water temperature : 6 °C.
- Inlet water temperature : 11 °C.
- Outdoor air temperature : 30 °C.
- Altitude : 0 m.

In the performance table on Page 13, the model 20 will supply cooling capacity of 21.7 kW with a power consumption of 6.8 kW.

Comment : Interpolation is authorised for conditions differing from those indicated in the performance table. However, extrapolation is prohibited.

The water flow will be equal to $(21.7 \text{ kW} / 5 \text{ K}) \times 860 = 3732 \text{ l/h}$.

Determine the unit's available pressure from the curves on pages 17 and 18 or the evaporator water pressure drops from the curves on pages 19 and 20.

Operating temperature range - Cooling mode

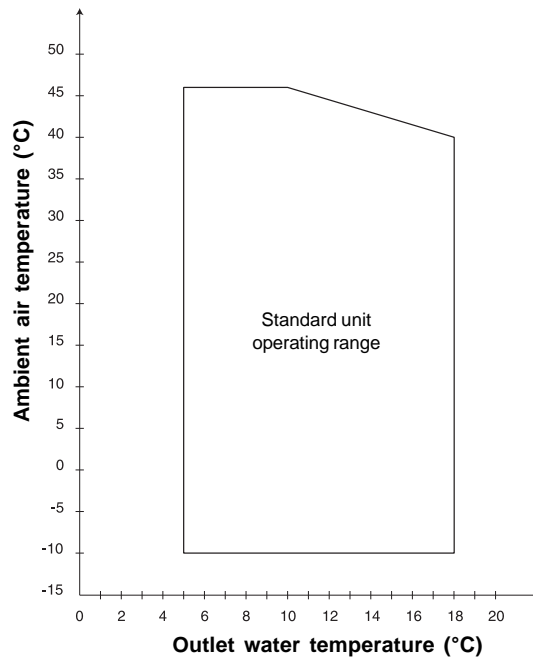

Operating temperature range - Heating mode

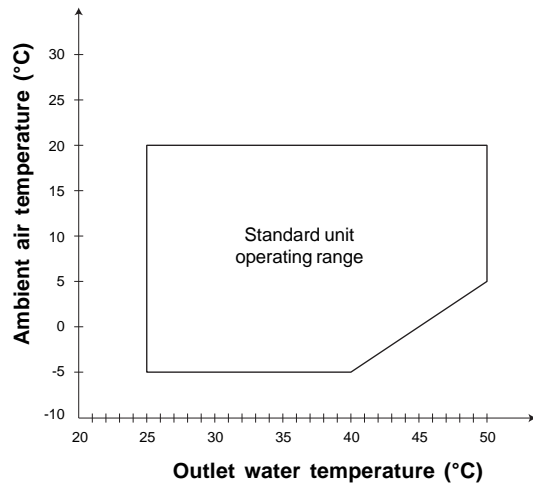

Selection guide (continued)

Operating limits (*) - Cooling mode

Temperature		min.	max
Inlet water at start-up	°C	10	30
Inlet water during running	°C	10	23
Outlet water during running (without glycol)	°C	5	18
Water temperature difference	K	3	7
Working pressure	bar	-	3
Air	°C	-10	46

(*) For chilled water $\Delta T = 5K$.

Chilled water inlet/outlet temperature correction factors

Chilled water in/out temp. (°C)	Cooling capacity correction factors	Power consumption correction factors
14 / 7 ($\Delta T=7 K$)	0.970	0.990
12 / 7 ($\Delta T=5 K$)	1.000	1.000
10 / 7 ($\Delta T=3 K$)	1.030	1.010

Evaporator fouling factors

Fouling factors (m ² .°C/kW)	Cooling capacity correction factors	Power consumption correction factors
0.044	1.000	1.000
0.088	0.987	0.995
0.176	0.964	0.985
0.352	0.915	0.962

Operating limits (*) - Heating mode

Temperature		min.	max
Inlet water at start-up	°C	18	-
Inlet water during running	°C	20	45
Outlet water during running (without glycol)	°C	25	50
Water temperature difference	K	3	7
Working pressure	bar	-	3
Air	°C	-5	20

(*) For hot water $\Delta T = 5K$.

Altitude correction factors

Altitude (m)	Cooling capacity correction factors	Power consumption correction factors
0	1.000	1.000
600	0.987	1.010
1200	0.973	1.020
1800	0.958	1.029
2400	0.943	1.038

Condenser fouling factors

Fouling factors (m ² .°C/kW)	Cooling capacity correction factors	Power consumption correction factors
0.044	1.000	1.000
0.088	0.987	1.023
0.176	0.955	1.068
0.352	0.910	1.135

Hydraulic circuit water volume

Minimum volume for comfort air conditioning applications

Sizes	20	25	30	35	40	50	60	70	80	90	100	110	120	130
Volume* (litres)	54	65	75	86	105	120	145	170	190	220	245	280	310	330

(*) Volumes calculated for Eurovent operating conditions (air : 35 °C, water 12/7 °C) with a 2.5 l/kW ratio. For other nominal operating conditions, recalculate the minimum volume by multiplying the corresponding cooling capacity by the 2.5l/kW ratio.
If the minimum volume requirement can not be met, an additional buffer tank must be included in the installation.

Maximum volume (*) in litres for comfort air conditioning applications

Sizes	20 to 35	40 to 80	90 to 130
Water	300	600	1500
10% glycol solution	225	450	1200
15% glycol solution	215	425	1100
20% glycol solution	200	400	1000
25% glycol solution	185	375	930
30% glycol solution	175	350	860
35% glycol solution	150	300	800

(*) Limit linked to the unit's expansion tank volume. In the case of an installation with a water volume greater than the values stated in the above table, an additional buffer tank must be included in the installation.

Technical characteristics - HFC 407C

AQH sizes		20	25	30	35	40	50	60	70	80	
Power supply (V / Ph / Hz)		400/3+N/50									
Cooling capacity (1)	kW	21.5	26	29.9	34.2	39.5	47.9	55.9	67	75	
Heating capacity (2)	kW	23.1	28	32.9	37.4	45	56	65	78	84.9	
Total power consumption with pump (3)	kW	8.4	10	11.4	12.2	16.1	19.4	23.9	28.1	30.7	
Total power consumption (3)	kW	7.6	9.2	10.6	11.4	15.4	18.7	22.8	27	29.6	
Total power consumption with pump (4)	kW	8.6	10	11.4	11.4	16.4	19.4	24.2	28.6	31.5	
Total power consumption (4)	kW	7.8	9.2	10.6	10.6	15.6	18.6	23.1	27.5	30.4	
COP		3.1	3.1	3.1	3	2.8	2.7	2.7	2.7	2.7	
Refrigerant charge	kg	6.4	6.4	6.4	7.6	9	11.5	13	14	16	
Lw sound power levels	dB(A)	75	76	76	77	82	82	84	87	87	
Compressors											
Type	Scroll - Hermetically sealed										
Quantity		2	2	2	2	2	2	2	2	2	
Capacity reduction stages		2	2	2	2	2	2	2	2	2	
Minimum capacity	%	50	50	50	50	45	36	36	45	50	
Safety pressostat	HP (fixed set point) LP transducer HP transducer										
Evaporator											
Type	Braze stainless steel plates										
Maximum pressure refrigerant side	bar	30									
Maximum pressure water side	bar	10									
Safety	Differential pressostat					Water flow switch					
Anti-freeze protection heating resistance		1	1	1	1	1	1	1	1	1	
Water volume	litres	1.67	2.2	2.44	2.44	3.44	4.33	5.33	6.33	7.10	
Condenser											
Type	3/8" copper tube - Louvred aluminium fins										
Fans											
Quantity		2	2	2	2	1	1	1	1	1	
Fan diameter	mm	610	610	610	610	800	800	800	800	800	
Speed (High/Low)	rpm	640/500	640/500	640/500	640/500	700/500	700/500	700/500	900/520	900/520	
Max. air flow (HS)	m ³ /h	11200	11200	11200	11200	15500	15500	15500	21000	21000	
Water connections											
Type	Gas - Threaded					Gas - Threaded					
Diameter	inches	1"1/2	1"1/2	1"1/2	1"1/2	2"	2"	2"	2"	2"	
Expansion tank	litres	5					12				
Filter	1" 1/2, supplied loose					2", supplied fitted					
Safety valve calibration	bar	3	3	3	3	3	3	3	3	3	
Water circulation pump											
Type	Single speed centrifugal pump										
Material	AISI 304 stainless steel					Composite					
Protection index	IP54					IP54					
Three phase motor	Class F					Class F					
Weight											
With pump	kg	286	296	306	305	510	585	590	620	640	
Without pump	kg	271	281	291	290	490	565	570	600	620	
Dimensions											
Length	mm	1477	1477	1477	1477	1737	2168	2168	2168	2168	
Width	mm	516	516	516	516	1201	1201	1201	1201	1201	
Height	mm	1607	1607	1607	1607	1634	1634	1634	1634	1634	

(1) Values based on chilled water inlet/outlet temperatures of 12/7° C and an ambient air temperature of 35° C.

(2) Values based on hot water inlet/outlet temperatures of 40/45 °C and an ambient air temperature of 7 °C.

(3) Cooling mode data.

(4) Heating mode data.

Technical characteristics - HFC 407C (continued)

AQH sizes		90	100	110	120	130
Power supply (V / Ph / Hz)		400/3/50				
Cooling capacity (1)	kW	86.4	98.0	112.0	122.2	131.0
Heating capacity (2)	kW	95.4	106.6	125.6	135.8	141.0
Compressor power consumption (3)	kW	31.0	35.7	39.8	44.4	43.0
Total power consumption (3)	kW	43.2	48.4	54.9	60.1	62.0
Compressor power consumption (4)	kW	31.0	36.5	38.8	42.5	42.3
Total power consumption (4)	kW	44.4	49.6	56.5	61.7	63.6
COP - Cooling mode		2.8	2.7	2.8	2.8	3.0
COP - Heating mode		3.0	2.9	3.2	3.2	3.3
Refrigerant charge	kg	24	28	30	34	34
Lw sound power levels	dB(A)	86	87	87	87	90
Compressors						
Type		Scroll - Hermetically sealed				
Quantity		2	2	2	2	2
Capacity reduction stages		2	2	2	2	2
Minimum capacity	%	45 / 55	40 / 60	45 / 55	50 / 50	50 / 50
Safety pressostat		HP (fixed set point) LP transducer HP transducer				
Evaporator						
Type		Brazed stainless steel plates				
Maximum pressure refrigerant side	bar	30				
Maximum pressure water side	bar	10				
Safety		Water flow switch				
Anti-freeze protection heating resistance	W	70	70	70	70	70
Water volume	litres	7.1	8.4	10.3	11.3	13.9
Fans						
Quantity		2	2	2	2	2
Fan diameter	mm	800	800	800	800	800
Speed (High/Low)	rpm	700/500	700/500	700/500	700/500	900/520
Max. air flow (HS)	m³/h	30000	30000	30000	30000	40000
Water connections						
Type		Gas - Male threaded				
Diameter	inches	2"	2"	2"	2"	2"
Weight						
Shipping weight	kg	1000	1050	1100	1100	1120
Dimensions						
Length	mm	2523	2865	2865	2865	2865
Width	mm	1201	1201	1201	1201	1201
Height	mm	1634	1634	1634	1634	1634

(1) Values based on chilled water inlet/outlet temperatures of 12/7° C and an ambient air temperature of 35° C.

(2) Values based on hot water inlet/outlet temperatures of 40/45 °C and an ambient air temperature of 7 °C.

(3) Cooling mode data.

(4) Heating mode data.

Technical characteristics - HFC 407C (continued)

Protection devices

AQH sizes	20	25	30	35	40	50	60	70	80	90	100	110	120	130
Fan thermal protection	yes													
Compressors thermal protection										yes				
Ancillaries / Fan circuit breakers										yes				
Compressors circuit breakers			yes											
Water pressure differential pressostat			yes											
Water flow switch										yes				
HP pressostat										yes				
Evaporator anti-freeze protection										yes				
HP transducer										yes				
LP transducer										yes				

Lw (A) sound power levels

AQH sizes	Frequency in octave band (Hz)								Global dBA
	63	125	250	500	1000	2000	4000	8000	
20	55	63	67	73	64	62	60	57	75
25	56	64	68	74	65	63	61	58	76
30	56	64	68	74	65	63	61	58	76
35	57	65	69	75	66	64	62	59	77
40	62	70	74	80	74	70	67	64	82
50	62	70	74	80	74	70	67	64	82
60	63	71	75	82	75	71	68	65	84
70	67	75	79	84	75	74	72	69	87
80	67	80	84	84	75	79	77	74	87
90	80	79	73	79	80	76	71	61	86
100	81	81	74	80	80	78	73	61	87
110	81	81	74	80	80	78	73	61	87
120	81	81	74	80	80	78	73	61	87
130	86	86	79	85	85	83	83	67	90

Lp (A) sound pressure levels

AQH sizes	Frequency in octave band (Hz)								Global dBA
	63	125	250	500	1000	2000	4000	8000	
20	39	47	51	57	48	46	44	41	59
25	40	48	52	58	49	47	45	42	60
30	40	48	52	58	49	47	45	42	60
35	41	49	53	59	50	48	46	43	61
40	46	54	58	64	58	54	51	48	65
50	46	54	58	64	58	54	51	48	65
60	47	55	59	65	58	54	52	48	67
70	51	59	63	68	59	58	56	53	70
80	51	64	68	68	59	63	61	58	70
90	63	62	56	62	63	59	54	44	69
100	63	63	56	61	61	60	55	43	69
110	63	63	56	61	61	60	55	43	69
120	63	63	56	61	61	60	55	43	69
130	68	68	61	67	67	65	65	49	72

Sound pressure levels indicated at 1 m from the unit in a free field condition.

Electrical characteristics - HFC 407C

Unit with hydraulic module

AQH sizes		20	25	30	35	40	50	60	70	80	90	100	110	120	130	
Supply voltage (V / Ph / Hz)		400 / 3+N / 50										400 / 3 / 50				
Permissible voltage		380-420										380-420				
Nominal power consumption	kW	8.4	10.0	11.4	13.5	16.1	19.4	23.9	28.1	30.7	34.7	39.4	43.8	48.4	48.8	
Maximum power consumption	kW	10.0	14.2	16.2	16.6	20.1	25.3	30.0	36.1	38.9	44.7	49.9	56.7	61.9	63.8	
Nominal current	A	18.3	21.5	22.9	27.7	31.0	36.0	42.9	49.5	53.3	64.3	71.4	79.6	86.7	89.9	
Maximum current	A	21.3	29.3	31.3	33.3	38.5	46.5	53.5	63.1	67.1	76.3	85.0	95.4	104.1	107.3	
Maximum starting current	A	65	83	92	121	145	189	222	231	235	253	308	318	327	330	
External fuse	A	25	32	32	40	50	50	63	63	80	100	100	125	125	125	
Cable section (100 m max.)	mm ²	6	10	10	10	16	16	25	25	25	35	35	50	50	50	

Unit without hydraulic module

AQH sizes		20	25	30	35	40	50	60	70	80	90	100	110	120	130	
Supply voltage (V / Ph / Hz)		400 / 3+N / 50										400 / 3 / 50				
Permissible voltage		380-420										380-420				
Nominal power consumption	kW	7.6	9.2	10.6	12.8	15.4	18.7	22.8	27.0	29.6	33.2	37.9	42.0	46.6	47.0	
Maximum power consumption	kW	9.2	13.3	15.4	15.9	19.4	24.5	28.9	35.0	37.8	43.2	48.4	54.9	60.1	62.0	
Nominal current	A	16.6	19.8	21.2	26.0	28.9	33.9	39.8	46.4	50.2	60.5	67.6	74.7	81.8	85.0	
Maximum current	A	19.6	27.6	29.6	31.6	36.4	44.4	50.4	60.0	64.0	72.5	81.2	90.5	99.2	102.4	
Maximum starting current	A	64	82	91	120	142	186	218	228	232	249	304	313	322	325	
External fuse	A	25	32	32	40	50	50	63	63	80	100	100	125	125	125	
Cable section (100 m max.)	mm ²	6	10	10	10	16	16	25	25	25	35	35	50	50	50	

Compressors

AQH sizes		20	25	30	35	40	50	60
Nominal power consumption	kW	3.5 + 3.5	4.3 + 4.3	5.0 + 5.0	6.1 + 6.1	7.9 + 6.4	11.2 + 6.4	13.8 + 7.6
Maximum power consumption	kW	4 + 4	6 + 6	7 + 7	8 + 8	10 + 8	15 + 8	18 + 10
Nominal current	A	6.5 + 6.5	8.1 + 8.1	8.8 + 8.8	11.2 + 11.2	14.3 + 12.2	19.3 + 12.2	23.1 + 14.3
Maximum current	A	8 + 8	12 + 12	13 + 13	14 + 14	18 + 16	26 + 16	30 + 18
Crankcase heater	W	70 + 70	70 + 70	70 + 70	70 + 70	70 + 70	70 + 70	70 + 70

AQH sizes		70	80	90	100	110	120	130
Nominal power consumption	kW	13.8 + 11.2	13.8 + 13.8	17.6 + 13.4	22 + 13.7	23.9 + 15.9	22.2 + 22.2	21.5 + 21.5
Maximum power consumption	kW	18 + 15	18 + 18	24 + 17	29 + 17	29 + 24	29 + 29	29 + 29
Nominal current	A	23.1 + 19.3	23.1 + 23.1	31.4 + 24.3	38.5 + 24.3	38.5 + 31.4	38.5 + 38.5	38.5 + 38.5
Maximum current	A	30 + 26	30 + 30	38.5 + 29	47 + 29	47 + 38.5	47 + 47	47 + 47
Crankcase heater	W	70 + 70	70 + 70	130 + 75	130 + 75	130 + 130	130 + 130	130 + 130

Standard condenser fans

AQH sizes		20	25	30	35	40	50	60	70	80	90	100	110	120	130	
Supply voltage (V / Ph / Hz)		230 / 1 / 50					400 / 3 / 50									
Quantity		2	2	2	2	1	1	1	1	1	2	2	2	2	2	
Nominal power consumption	kW	0.3	0.3	0.3	0.3	1.1	1.1	1.1	2	2	1.1	1.1	1.1	1.1	2	
Nominal current consumption	A	1.8	1.8	1.8	1.8	2.4	2.4	2.4	4	4	2.4	2.4	2.4	2.4	4	

Standard pumps

AQH sizes		20	25	30	35	40	50	60	70	80	90	100	110	120	130	
Supply voltage (V / Ph / Hz)		400 / 3 / 50														
Nominal power consumption	kW	0.8	0.8	0.8	0.7	0.8	0.8	1.1	1.1	1.1	1.5	1.5	1.8	1.8	1.8	
Nominal current consumption	A	1.7	1.7	1.7	1.7	2.1	2.1	3.1	3.1	3.1	3.8	3.8	4.9	4.9	4.9	

Evaporator heating resistance

AQH sizes		20	25	30	35	40	50	60	70	80	90	100	110	120	130	
Supply voltage (V / Ph / Hz)		230 / 1 / 50														
Maximum power consumption	W	35	35	35	35	35	35	35	35	35	35+35	35+35	35+35	35+35	35+35	

Performance data in cooling mode - HFC 407C

AQH sizes	Outdoor air temperature (°C)														
	LCWT (°C)	25		30		32		35		40		43		46	
		Pf	Pabs	Pf	Pabs	Pf	Pabs	Pf	Pabs	Pf	Pabs	Pf	Pabs	Pf	Pabs
20	5	21.6	6.1	21.0	6.8	20.8	7.1	20.4	7.5	18.7	8.2	17.8	8.7	16.8	9.2
	6	22.3	6.1	21.7	6.8	21.4	7.1	21.0	7.5	19.3	8.2	18.4	8.7	17.3	9.3
	7	23.0	6.1	22.4	6.9	22.1	7.2	21.5	7.6	20.0	8.3	19.0	8.8	17.9	9.3
	8	23.8	6.2	23.2	6.9	22.9	7.2	22.4	7.6	20.7	8.4	19.6	8.8	18.5	9.4
	9	24.5	6.2	23.9	7.0	23.6	7.2	23.1	7.7	21.3	8.4	20.3	9.0	19.2	9.5
25	5	26.5	7.5	25.8	8.2	25.5	8.6	24.9	9.0	22.9	9.9	21.8	9.9	20.6	10.4
	6	27.4	7.6	26.7	8.3	26.3	8.6	25.7	9.1	23.8	10.0	22.5	10.0	21.3	10.5
	7	28.3	7.7	27.6	8.4	27.2	8.7	26.0	9.2	24.6	10.1	23.2	10.1	22.0	10.6
	8	29.2	7.7	28.4	8.5	28.0	8.8	27.5	9.3	25.3	10.1	24.0	10.1	22.8	10.7
	9	30.1	7.8	29.3	8.5	29.0	8.9	28.4	9.4	26.1	10.2	24.9	10.2	23.5	10.8
30	5	31.0	8.6	29.6	9.4	29.0	9.8	28.1	10.4	26.3	11.4	25.1	12.1	24.0	12.7
	6	31.9	8.7	30.5	9.5	29.9	9.9	29.0	10.5	27.1	11.5	26.0	12.2	24.8	12.8
	7	32.9	8.8	31.4	9.6	30.8	10.0	29.9	10.6	27.9	11.7	26.8	12.3	25.7	12.9
	8	33.8	8.8	32.4	9.7	31.7	10.1	30.8	10.7	28.8	11.8	27.7	12.4	26.5	13.0
	9	34.8	8.9	33.3	9.8	32.7	10.2	31.7	10.8	29.7	11.8	28.5	12.4	27.2	13.2
35	5	34.9	9.5	33.6	10.4	33.0	10.7	32.1	11.2	29.4	12.4	27.9	13.3	26.2	14.1
	6	36.0	9.6	34.6	10.5	34.1	10.8	33.2	11.3	30.5	12.6	28.8	13.4	27.2	14.2
	7	37.0	9.8	35.7	10.6	35.1	11.0	34.2	11.4	31.5	12.7	29.8	13.5	28.2	14.4
	8	38.1	9.9	36.8	10.7	36.2	11.1	35.3	11.5	32.6	12.8	30.9	13.6	29.2	14.4
	9	39.3	10.0	38.0	10.9	37.4	11.2	36.4	11.6	33.7	12.9	32.0	13.7	30.3	14.5
40	5	39.6	12.7	38.4	14.0	38.0	14.5	37.3	15.3	34.5	16.7	32.8	17.6	31.1	18.7
	6	40.7	12.8	39.7	14.1	39.1	14.6	38.3	15.4	35.5	16.9	33.9	17.8	32.1	18.8
	7	41.9	12.8	40.8	14.2	40.3	14.7	39.5	15.5	36.6	17.0	34.8	17.9	33.0	18.9
	8	43.1	13.0	41.9	14.3	41.4	14.8	40.6	15.6	37.7	17.1	35.8	18.0	34.0	19.1
	9	44.3	13.1	43.2	14.4	42.6	14.9	41.8	15.7	38.8	17.2	36.9	18.2	35.1	19.2
50	5	48.3	15.4	46.8	16.8	46.3	17.4	45.3	18.3	41.6	20.0	39.5	21.0	37.4	22.1
	6	49.7	15.5	48.3	17.0	47.6	17.6	46.5	18.5	42.9	20.2	40.7	21.2	38.5	22.3
	7	51.1	15.7	49.6	17.2	49.0	17.8	47.9	18.7	44.1	20.4	41.9	21.4	39.6	22.6
	8	52.5	15.9	51.0	17.3	50.3	17.9	49.2	18.9	45.5	20.7	43.1	21.7	40.8	22.8
	9	54.0	16.0	52.4	17.5	51.8	18.1	50.6	19.1	46.7	20.9	44.4	21.9	42.1	23.0
60	5	56.4	18.8	54.7	20.5	54.0	21.2	52.8	22.3	48.8	24.4	46.5	25.7	44.0	26.9
	6	58.0	18.9	56.3	20.7	55.6	21.4	54.4	22.6	50.2	24.6	47.7	25.9	45.3	27.2
	7	59.6	19.1	57.9	21.0	57.1	21.7	55.9	22.8	51.7	24.9	49.0	26.1	46.5	27.5
	8	61.3	19.4	59.5	21.1	58.7	21.9	57.4	23.0	53.0	25.2	50.3	26.5	47.7	27.8
	9	62.9	19.5	61.1	21.3	60.3	22.1	59.0	23.3	54.5	25.4	51.8	26.7	49.0	28.1
70	5	69.9	22.3	66.8	24.3	65.6	25.1	63.7	26.6	59.6	28.9	57.0	30.4	54.6	31.9
	6	72.0	22.3	68.9	24.5	67.6	25.4	65.5	26.8	61.3	29.2	58.8	30.7	56.2	32.2
	7	74.0	22.5	70.8	24.7	69.5	25.6	67.0	27.0	63.1	29.4	60.5	30.9	57.9	32.6
	8	76.2	22.7	72.9	24.9	71.5	25.8	69.4	27.2	65.0	29.7	62.2	31.3	59.5	32.9
	9	78.3	23.0	74.9	25.1	73.6	26.0	71.3	27.4	66.8	30.0	64.1	31.5	61.2	33.1
80	5	75.5	24.3	73.4	26.6	72.5	27.6	70.9	29.1	65.6	31.6	62.4	33.3	59.3	35.0
	6	77.7	24.4	75.4	26.8	74.5	27.8	73.0	29.4	67.5	32.0	64.2	33.7	61.0	35.4
	7	79.9	24.7	77.6	27.1	76.6	28.0	75.1	29.6	69.3	32.2	66.0	33.9	62.6	35.7
	8	82.0	24.9	79.7	27.3	78.7	28.3	77.1	29.8	71.3	32.6	67.8	34.3	64.3	36.1
	9	84.3	25.2	81.9	27.6	80.8	28.5	79.2	30.1	73.2	32.8	69.6	34.5	66.1	36.3
10	86.5	25.4	84.1	27.8	83.0	28.9	81.3	30.4	75.1	33.2	71.5	34.9	67.8	36.7	

All the cooling capacity and power consumption values are expressed in kW.

The values indicated in **bold** are based on Eurovent conditions (chilled water inlet / outlet temperatures of 12 / 7 °C and an outdoor air temperature of + 35 °C).

The power consumption values stated in the table include compressors and fans in operation.

LCWT: Leaving Chilled Water Temperature

Pf : Cooling capacity

Pabs : Power consumption

Performance data in cooling mode - HFC 407C (continued)

AQH sizes	Outdoor air temperature (°C)														
	LCWT (°C)	25		30		32		35		40		43		46	
		Pf	Pabs	Pf	Pabs	Pf	Pabs	Pf	Pabs	Pf	Pabs	Pf	Pabs	Pf	Pabs
90	5	87.6	28.3	84.7	30.3	83.4	31.2	81.4	32.5	75.4	35.8	71.7	37.9	68.1	40.2
	6	90.2	28.6	87.2	30.7	85.8	31.5	83.8	32.8	77.6	36.2	73.9	38.3	70.1	40.6
	7	92.9	28.9	89.8	31.0	88.5	31.8	86.4	33.2	80.0	36.6	76.2	38.7	72.4	41.0
	8	95.5	29.3	92.5	31.4	91.1	32.2	88.9	33.6	82.4	37.0	78.5	39.1	74.5	41.4
	9	98.4	29.6	95.2	31.7	93.7	32.6	91.5	33.8	84.8	37.3	80.8	39.5	76.8	41.8
	10	101.1	29.9	97.9	32.1	96.4	32.9	94.2	34.2	87.3	37.7	83.1	39.9	79.0	42.2
100	5	99.3	32.3	96.1	34.7	94.7	35.7	92.4	37.2	85.4	40.9	81.3	43.3	77.1	45.8
	6	102.3	32.7	98.9	35.1	97.5	36.1	95.1	37.5	88.0	41.3	83.7	43.7	79.3	46.2
	7	105.2	33.1	101.9	35.5	100.4	36.4	98.0	37.9	90.6	41.7	86.2	44.2	81.7	46.7
	8	108.3	33.5	104.8	36.0	103.3	36.8	100.8	38.4	93.3	42.2	88.8	44.6	84.1	47.1
	9	111.4	33.9	107.7	36.3	106.2	37.3	103.6	38.8	95.9	42.6	91.2	45.0	86.7	47.4
	10	114.4	34.3	110.7	36.7	109.1	37.7	106.6	39.2	98.6	43.0	93.8	45.4	89.0	47.9
110	5	115.2	36.0	111.7	38.5	110.0	39.5	107.6	41.1	99.8	45.3	95.2	47.9	90.5	50.6
	6	118.7	36.4	114.9	39.0	113.3	40.0	110.8	41.5	102.9	45.7	98.1	48.3	93.3	51.2
	7	122.1	36.9	118.3	39.4	116.7	40.5	112.0	42.0	106.1	46.2	101.1	48.9	96.2	51.7
	8	125.6	37.3	121.7	39.9	120.1	41.0	117.4	42.6	109.2	46.7	104.1	49.4	99.1	52.2
	9	129.2	37.7	125.2	40.4	123.5	41.4	120.9	43.1	112.4	47.3	107.2	50.0	102.1	52.7
	10	132.8	38.2	128.8	40.9	127.1	41.9	124.3	43.5	115.5	47.9	110.3	50.6	105.0	53.3
120	5	123.4	39.7	119.8	42.6	118.1	43.8	115.4	45.5	107.2	50.0	102.1	52.8	97.1	55.8
	6	127.1	40.2	123.2	43.1	121.5	44.3	118.9	46.0	110.3	50.6	105.1	53.4	99.9	56.4
	7	130.6	40.7	126.8	43.7	125.1	44.8	122.2	46.6	113.5	51.1	108.2	54.0	102.8	56.9
	8	134.3	41.3	130.4	44.2	128.5	45.4	125.7	47.1	116.7	51.7	111.3	54.6	105.6	57.6
	9	138.1	41.8	134.0	44.8	132.1	46.0	129.2	47.7	119.9	52.3	114.3	55.2	108.7	58.2
	10	141.8	42.4	137.6	45.4	135.8	46.5	132.7	48.3	123.2	53.0	117.4	55.8	111.6	58.9
130	5	131.1	40.3	127.3	43.3	125.6	44.4	122.9	46.1	114.0	50.6	108.7	53.4	103.4	56.4
	6	135.1	40.8	131.2	43.8	129.4	44.9	126.6	46.7	117.7	51.2	112.1	54.0	106.6	57.0
	7	139.3	41.3	135.2	44.3	133.4	45.5	131.0	47.0	121.2	51.7	115.5	54.6	109.8	57.6
	8	143.4	41.8	139.3	44.8	137.3	45.9	134.3	47.7	124.8	52.3	118.9	55.2	113.1	58.2
	9	147.7	42.4	143.4	45.3	141.5	46.5	138.3	48.3	128.4	52.8	122.5	55.7	116.4	58.7
	10	152.0	42.9	147.5	45.8	145.5	47.0	142.4	48.7	132.2	53.4	126.0	56.4	119.7	59.3

All the cooling capacity and power consumption values are expressed in kW.

The values indicated in **bold** are based on Eurovent conditions (chilled water inlet / outlet temperatures of 12 / 7 °C and an outdoor air temperature of + 35 °C).

The power consumption values stated in the table include compressors and fans in operation.

LCWT: Leaving Chilled Water Temperature

Pf : Cooling capacity

Pabs : Power consumption

Performance data in heating mode - HFC 407C

AQH sizes	Outdoor air temperature (°C)														
	LHWT (°C)	-5		-3		0		5		7		10		15	
		Pc	Pabs	Pc	Pabs	Pc	Pabs	Pc	Pabs	Pc	Pabs	Pc	Pabs	Pc	Pabs
20	30	15.5	5.5	17.0	5.5	18.9	5.6	22.3	5.7	24.5	5.7	26.1	5.8	30.1	5.9
	35	15.4	6.2	16.9	6.2	18.7	6.3	22.0	6.3	24.0	6.4	25.6	6.4	29.4	6.4
	40	15.4	6.9	16.8	6.9	18.4	7.0	21.6	7.0	23.6	7.0	25.0	7.1	28.8	7.1
	45	15.4	7.6	16.6	7.6	18.2	7.6	21.2	7.8	23.2	7.8	24.6	7.9	28.1	8.0
	50					17.9	8.4	20.9	8.6	22.8	8.7	24.0	8.7	27.4	8.8
25	30	18.7	6.5	20.5	6.5	22.8	6.6	27.0	6.7	29.6	6.7	31.5	6.8	36.3	6.9
	35	18.7	7.3	20.5	7.3	22.6	7.4	26.5	7.4	29.0	7.5	30.9	7.5	35.6	7.6
	40	18.6	8.1	20.3	8.1	22.3	8.2	26.1	8.3	28.5	8.3	30.3	8.4	34.8	8.4
	45	18.6	8.9	20.0	8.9	22.0	9.0	25.6	9.2	28.0	9.2	29.7	9.3	33.9	9.4
	50					21.6	9.9	25.2	10.1	27.5	10.2	29.0	10.3	33.1	10.4
30	30	22.0	7.5	24.1	7.5	26.8	7.6	31.8	7.7	34.8	7.7	37.1	7.8	42.8	8.0
	35	22.0	8.4	24.1	8.4	26.6	8.5	31.2	8.5	34.2	8.7	36.4	8.7	41.9	8.8
	40	21.9	9.3	23.9	9.3	26.2	9.5	30.7	9.6	33.5	9.6	35.6	9.7	40.9	9.7
	45	21.8	10.3	23.5	10.3	25.8	10.4	30.2	10.6	32.9	10.6	34.9	10.7	39.9	10.8
	50					25.4	11.4	29.7	11.7	32.4	11.8	34.2	11.9	38.9	12.0
35	30	26.2	7.6	28.0	7.6	30.9	7.6	36.2	7.6	38.5	7.5	41.5	7.6	47.0	8.0
	35	26.2	8.7	28.0	8.7	30.8	8.6	36.0	8.5	38.3	8.5	41.1	8.7	46.4	9.0
	40	26.1	10.0	27.8	9.8	30.7	9.6	35.7	9.6	37.9	9.5	40.6	9.8	45.8	10.1
	45	26.1	11.4	27.8	11.1	30.6	10.9	35.3	10.7	37.4	10.6	40.0	11.0	45.0	11.4
	50					30.6	12.2	34.9	12.0	36.9	12.0	39.2	12.4	44.1	12.8
40	30	31.6	11.2	33.8	11.2	37.2	11.3	43.1	11.4	46.9	11.5	49.5	11.5	56.5	11.7
	35	32.1	12.2	33.4	12.3	36.8	12.5	42.6	12.7	46.3	12.7	48.8	12.8	55.5	12.9
	40	31.0	13.4	33.1	13.6	36.4	13.8	42.0	14.1	45.7	14.1	48.0	14.2	54.5	14.3
	45	30.7	14.8	32.8	15.0	36.0	15.2	41.5	15.5	45.0	15.6	47.3	15.8	48.7	15.9
	50					35.5	16.8	40.9	17.1	44.3	17.2	46.5	17.4	52.6	17.6
50	30	39.4	13.3	42.1	13.4	46.3	13.5	53.8	13.7	58.5	13.7	61.7	13.8	70.4	14.0
	35	40.0	14.6	41.7	14.8	45.9	14.9	53.1	15.2	57.7	15.2	60.8	15.3	69.2	15.5
	40	38.6	16.1	41.2	16.3	45.3	16.5	52.4	16.8	56.9	16.9	59.9	17.0	67.9	17.1
	45	38.3	17.7	40.8	17.9	44.8	18.2	51.7	18.6	56.1	18.7	58.9	18.9	60.6	19.0
	50					44.2	20.1	50.9	20.5	55.2	20.6	57.9	20.8	65.5	21.0
60	30	47.1	16.5	50.3	16.6	55.4	16.7	64.2	16.9	69.9	17.0	73.7	17.1	84.2	17.3
	35	47.8	18.1	49.8	18.2	54.8	18.5	63.4	18.8	68.9	18.8	72.6	19.0	82.7	19.1
	40	46.1	19.9	49.3	20.1	54.2	20.4	62.6	20.8	68.0	20.9	71.5	21.0	81.2	21.2
	45	45.7	21.9	48.8	22.2	53.6	22.5	61.8	23.0	65.0	23.1	70.4	23.4	72.4	23.5
	50					52.9	24.8	60.8	25.3	66.0	25.5	69.2	25.8	78.2	26.0
70	30	55.0	19.9	58.7	20.0	64.7	20.2	75.0	20.4	81.6	20.5	86.1	20.6	98.3	20.8
	35	55.8	21.8	58.1	22.0	64.0	22.3	74.1	22.6	80.5	22.7	84.8	22.8	96.6	23.0
	40	53.9	23.9	57.5	24.2	63.3	24.6	73.1	25.0	79.4	25.1	83.5	25.3	94.8	25.5
	45	53.4	26.4	57.0	26.7	62.6	27.1	72.1	27.6	78.0	27.5	82.2	28.1	84.6	28.3
	50					61.8	29.9	71.1	30.5	77.1	30.7	80.9	31.0	91.4	31.3
80	30	59.7	21.8	63.7	21.9	70.2	22.1	81.4	22.3	88.6	22.4	93.4	22.5	106.7	22.8
	35	60.5	23.8	63.1	24.1	69.4	24.4	80.4	24.8	87.4	24.9	92.1	25.0	104.8	25.2
	40	58.4	26.2	62.4	26.5	68.7	26.9	79.3	27.4	86.2	27.5	90.7	27.7	102.9	28.0
	45	58.0	28.9	61.8	29.3	67.9	29.7	78.3	30.3	84.9	30.5	89.2	30.8	91.8	31.0
	50					67.0	32.7	77.1	33.4	83.6	33.6	87.8	34.0	99.2	34.3

All the heating capacity and power consumption values are expressed in kW.

The values indicated in **bold** are based on : hot water of 40/45 °C and an outdoor air temperature of +7 °C.

The power consumption values stated in the table include compressors and fans in operation.

LHWT: Leaving Hot Water Temperature

Pc : Heating capacity

Pabs : Power consumption

Performance data in heating mode - HFC 407C (continued)

AQH sizes	Outdoor air temperature (°C)														
	LHWT (°C)	-5		-3		0		5		7		10		15	
		Pc	Pabs	Pc	Pabs	Pc	Pabs	Pc	Pabs	Pc	Pabs	Pc	Pabs	Pc	Pabs
90	30	68.2	24.5	72.7	24.5	79.9	24.5	92.6	24.6	98.4	24.6	105.2	25.4	117.8	26.7
	35	68.2	27.1	72.5	27.1	79.4	27.1	91.8	27.1	97.3	27.2	103.8	27.9	115.8	29.3
	40	68.5	30.2	72.6	30.1	79.2	29.9	91.0	29.9	96.3	29.9	102.5	30.8	113.9	32.3
	45	69.1	33.7	72.8	33.5	79.1	33.2	90.4	33.2	95.4	33.2	101.2	34.0	112.0	35.7
	50	69.7	36.4	73.2	36.2	79.1	35.9	89.9	35.5	94.9	35.4	100.6	36.1	111.2	37.1
100	30	75.3	27.9	79.7	28.0	87.5	28.1	101.4	28.3	107.6	28.5	115.1	29.4	129.0	31.1
	35	75.8	31.2	80.3	31.1	87.7	31.2	101.2	31.4	107.3	31.6	114.5	32.6	127.9	34.5
	40	76.6	34.7	80.8	34.7	88.0	34.6	101.1	34.8	107.0	35.0	113.9	36.1	126.7	38.1
	45	77.4	38.6	81.4	38.5	88.3	38.5	100.9	38.6	106.6	38.7	113.0	39.8	125.3	42.0
	50	77.6	39.8	81.6	39.8	88.4	39.7	100.8	40.4	106.3	41.1	112.3	43.3	123.7	46.3
110	30	87.5	29.9	93.6	30.0	103.6	30.1	121.2	30.4	129.0	30.5	138.5	31.5	156.0	33.3
	35	87.7	33.1	93.6	33.2	103.3	33.2	120.4	33.5	128.0	33.6	137.0	34.7	153.9	36.7
	40	87.7	36.6	93.4	36.6	102.9	36.8	119.5	37.0	126.8	37.2	135.5	38.3	151.8	40.4
	45	87.5	40.2	93.1	40.4	102.3	40.5	118.4	40.8	125.6	41.0	133.9	42.2	149.6	44.5
	50	87.2	43.8	92.7	43.9	101.7	44.1	117.6	44.0	124.6	44.0	132.9	44.9	148.5	46.7
120	30	95.1	32.3	101.5	32.4	111.7	32.6	130.0	32.9	138.3	33.0	148.1	34.0	166.5	36.1
	35	95.4	35.8	101.7	35.8	111.6	36.1	129.6	36.4	137.6	36.6	147.1	37.8	164.9	39.9
	40	95.6	39.6	101.7	39.7	111.5	40.0	129.0	40.3	136.8	40.5	145.9	41.8	163.1	44.2
	45	95.7	43.8	101.7	43.9	111.2	44.2	128.2	44.5	135.8	44.7	144.6	46.1	161.0	48.7
	50	95.7	47.7	101.6	47.8	110.9	47.9	127.5	47.9	134.9	48.0	143.6	49.1	159.8	51.1
130	30	100.0	34.0	106.5	34.1	117.2	34.3	136.7	34.5	145.3	34.7	155.7	35.7	175.3	37.7
	35	100.0	37.5	106.4	37.5	116.9	37.8	135.8	38.1	144.3	38.2	154.3	39.4	173.2	41.5
	40	100.0	41.2	106.2	41.4	116.5	41.6	134.8	42.0	143.0	42.1	152.7	43.4	170.8	45.8
	45	99.8	45.4	105.9	45.5	115.9	45.8	133.7	46.1	141.0	46.3	150.8	47.7	168.0	50.2
	50	99.5	49.8	105.5	49.9	115.2	50.0	132.5	50.0	140.2	50.0	149.2	51.2	166.1	53.2

All the heating capacity and power consumption values are expressed in kW.

The values indicated in **bold** are based on : hot water of 40/45 °C and an outdoor air temperature of +7 °C.

The power consumption values stated in the table include compressors and fans in operation.

LHWT: Leaving Hot Water Temperature

Pc : Heating capacity

Pabs : Power consumption

Unit external static pressure

Models 20, 25, 30 & 35

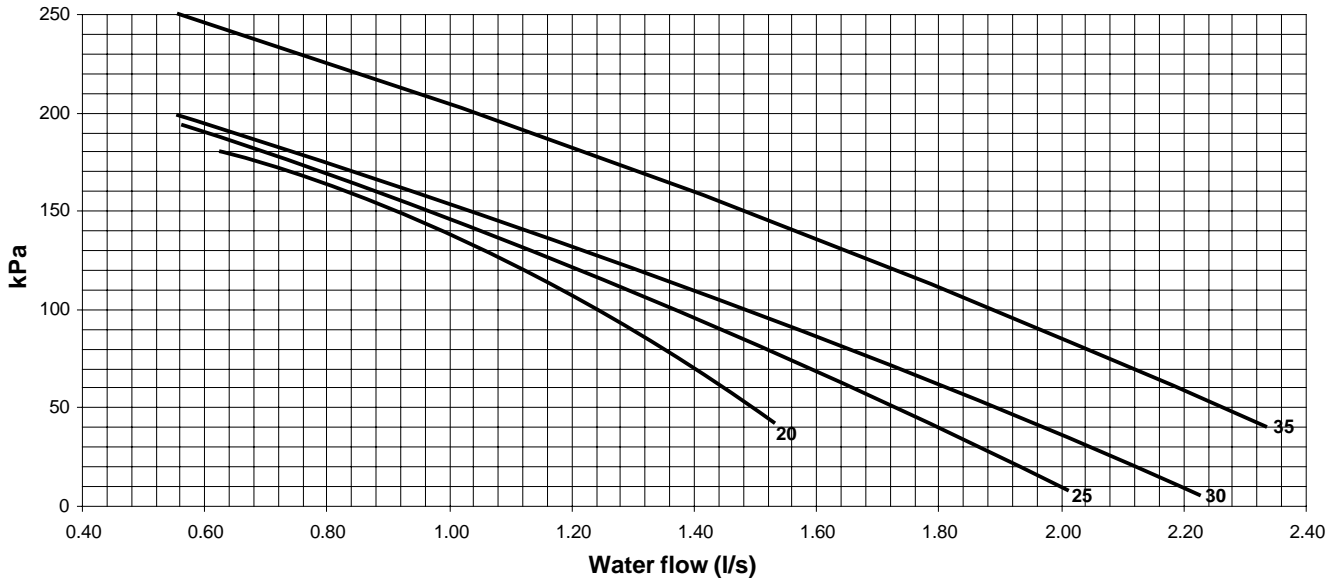

Cooling mode

Water flow (l/s)	Model 20	Model 25	Model 30	Model 35
Nominal (1)	1.03	1.24	1.43	1.63
Minimum (2)	0.69	0.83	0.95	1.09
Maximum (3)	1.71	2.07	2.38	2.72

- (1) Eurovent conditions, Water : 12 / 7 °C, Air : 35 °C.
- (2) With water Δt : 7.5 K at nominal capacity.
- (3) With water Δt : 3 K at nominal capacity.

Heating mode

Water flow (l/s)	Model 20	Model 25	Model 30	Model 35
Nominal (1)	1.1	1.3	1.57	1.79
Minimum (2)	0.74	0.87	1.04	1.19
Maximum (3)	1.84	2.17	2.61	2.98

- (1) Eurovent conditions, Water : 40 / 45 °C, Air : 7 °C.
- (2) With water Δt : 7.5 K at nominal capacity.
- (3) With water Δt : 3 K at nominal capacity.

Models 40, 50, 60, 70 & 80

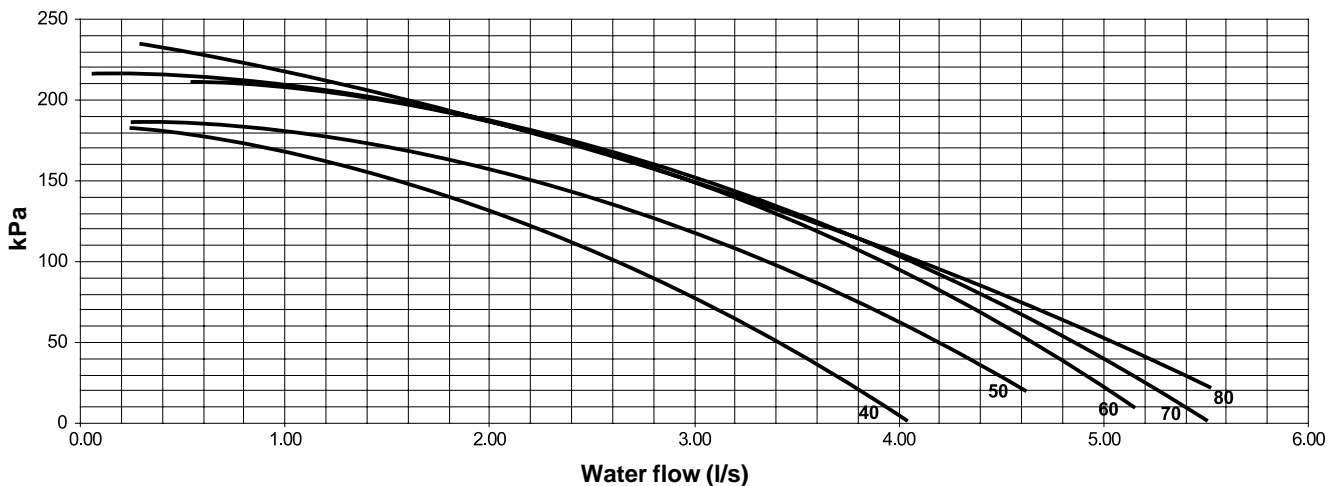

Cooling mode

Water flow (l/s)	Model 40	Model 50	Model 60	Model 70	Model 80
Nominal (1)	1.89	2.28	2.67	3.2	3.63
Minimum (2)	1.26	1.52	1.78	2.13	2.42
Maximum (3)	3.15	3.81	4.45	5.34	6.05

- (1) Eurovent conditions, Water : 12 / 7 °C, Air : 35 °C.
- (2) With water Δt : 7.5 K at nominal capacity.
- (3) With water Δt : 3 K at nominal capacity.

Heating mode

Water flow (l/s)	Model 40	Model 50	Model 60	Model 70	Model 80
Nominal (1)	2.15	2.58	2.96	3.49	3.82
Minimum (2)	1.43	1.72	1.97	2.33	2.55
Maximum (3)	3.58	4.3	4.94	5.81	6.37

- (1) Eurovent conditions, Water : 40 / 45 °C, Air : 7 °C.
- (2) With water Δt : 7.5 K at nominal capacity.
- (3) With water Δt : 3 K at nominal capacity.

Remark : the unit external static pressure curves are based on water average temperature of 10 °C.

Unit external static pressure (continued)

Models 90 to 130

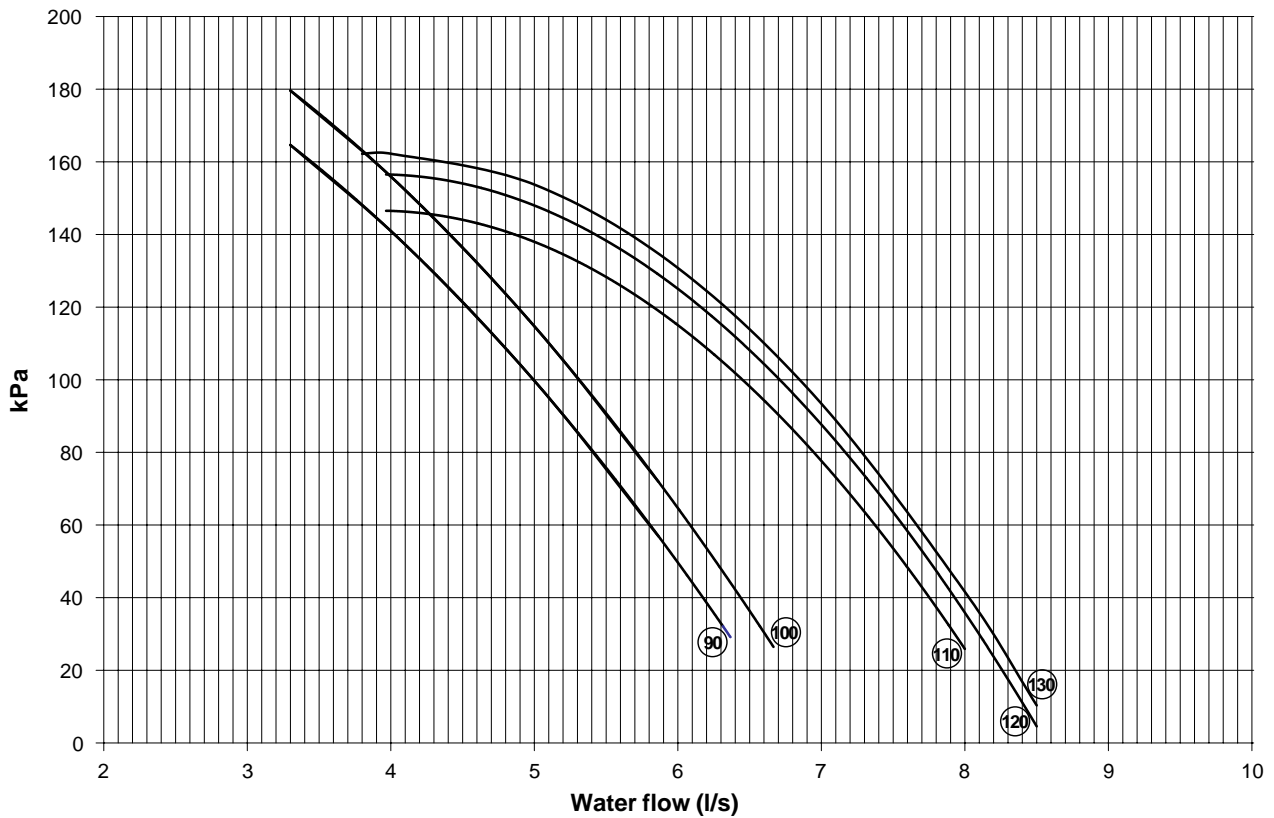

Cooling mode

Water flow (l/s)	Model 90	Model 100	Model 110	Model 120	Model 130
Nominal (1)	4.13	4.68	5.35	5.84	6.26
Minimum (2)	2.75	3.12	3.57	3.89	4.17
Maximum (3)	6.88	7.80	8.92	9.73	10.43

(1) Eurovent conditions, Water : 12 / 7 °C, Air : 35 °C.

(2) With water Δt : 7.5 K at nominal capacity.

(3) With water Δt : 3 K at nominal capacity.

Heating mode

Water flow (l/s)	Model 90	Model 100	Model 110	Model 120	Model 130
Nominal (1)	4.56	5.09	6.00	6.49	6.74
Minimum (2)	3.04	3.40	4.00	4.33	4.49
Maximum (3)	7.60	8.49	10.00	10.81	11.23

(1) Eurovent conditions, Water : 40 / 45 °C, Air : 7 °C.

(2) With water Δt : 7.5 K at nominal capacity.

(3) With water Δt : 3 K at nominal capacity.

Remark : the unit external static pressure curves are based on water average temperature of 10 °C.

Heat exchanger water pressure drop

Models 20, 25, 30 & 35

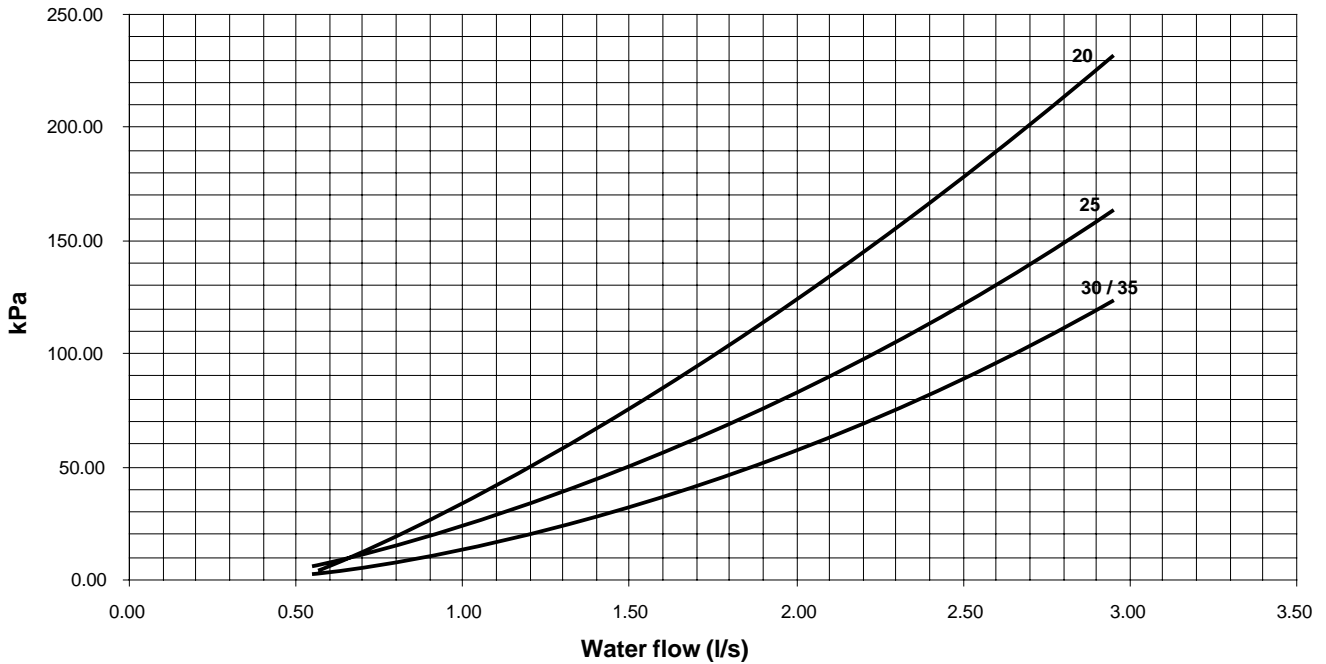

Models 40, 50, 60, 70 & 80

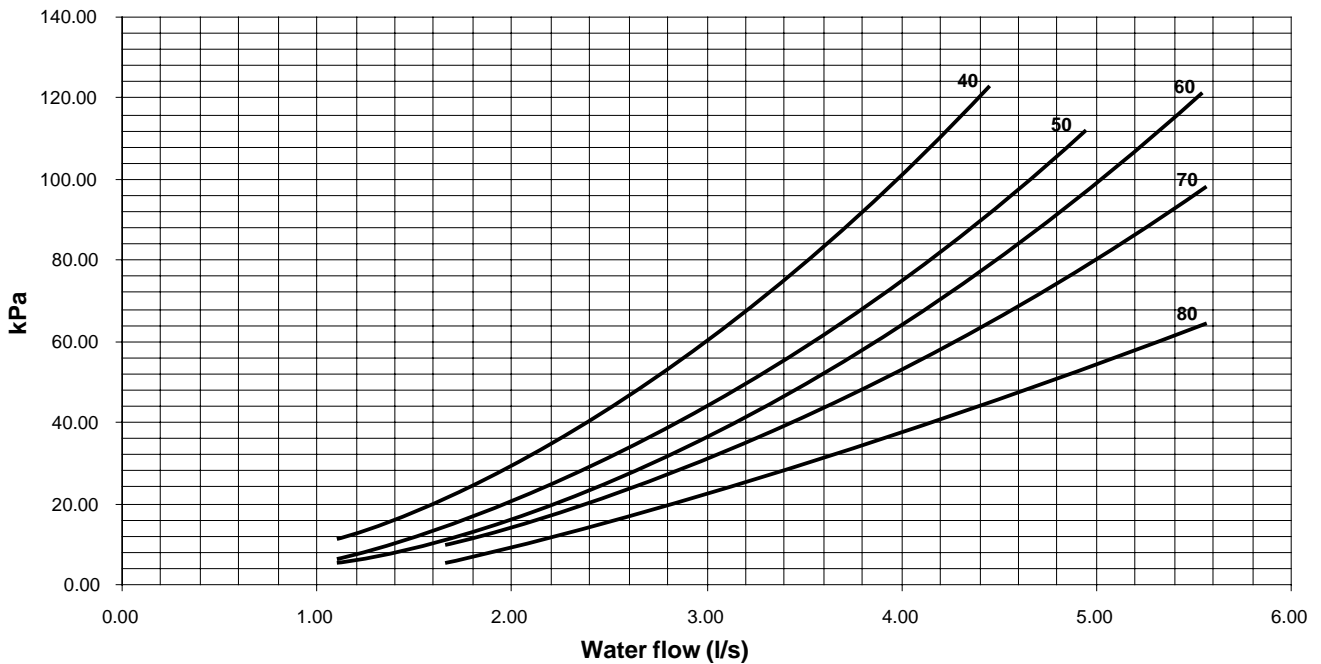

Remark : the heat exchanger water pressure drop curves are based on water average temperature of 10 °C. For temperatures different from 10 °C, use the correction factors as stated below :

Water average temperature (°C)	5	10	15	20	30	40	50
Correction factors	1.02	1.00	0.98	0.97	0.95	0.93	0.91

Heat exchanger water pressure drop (continued)

Models 90 to 130

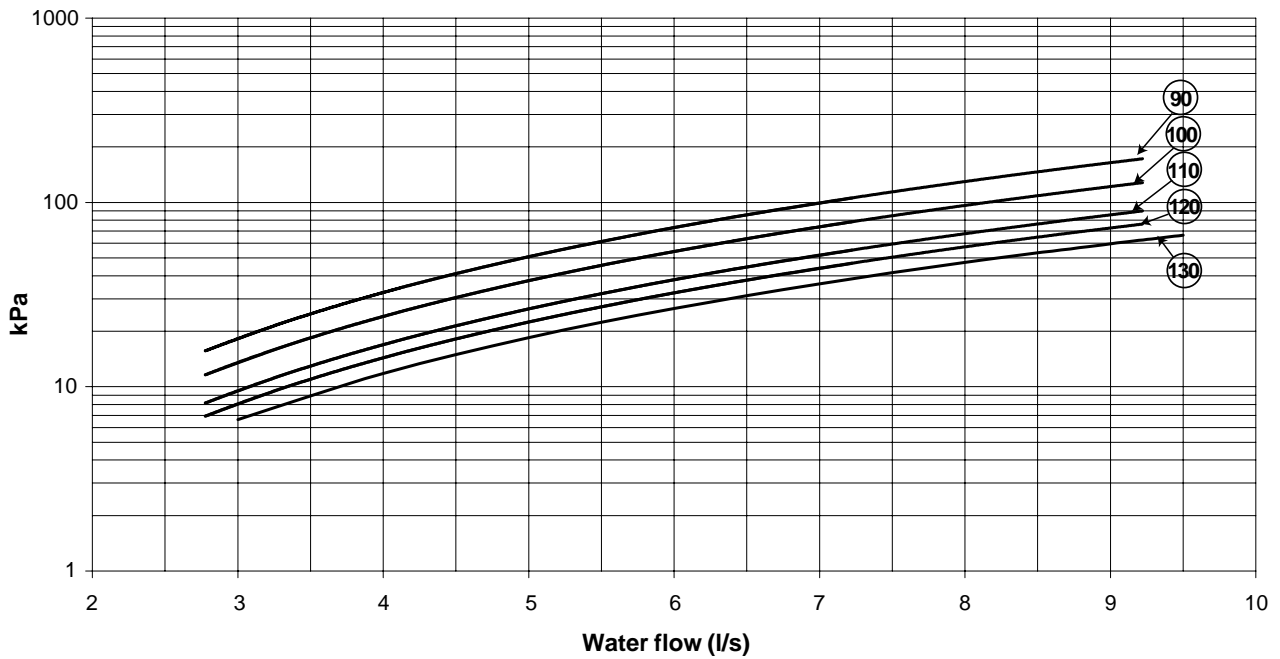

Remark : the heat exchanger water pressure drop curves are based on water average temperature of 10 °C. For temperatures different from 10 °C, use the correction factors as stated below :

Water average temperature (°C)	5	10	15	20	30	40	50
Correction factors	1.02	1.00	0.98	0.97	0.95	0.93	0.91

Dimensions - Aqu@Logic AQH sizes 20, 25, 30 and 35

Front view

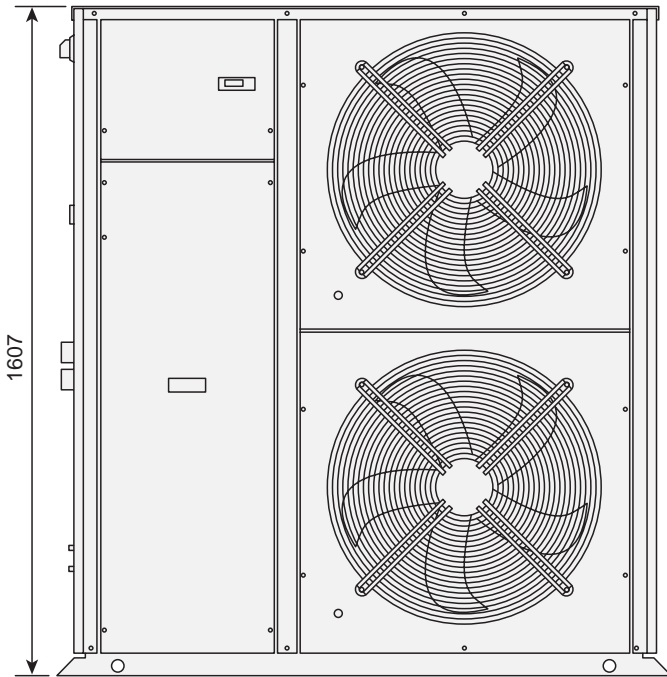

Side view

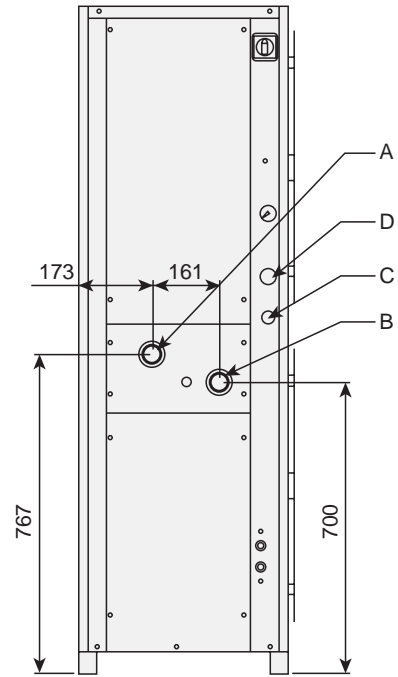

Top view

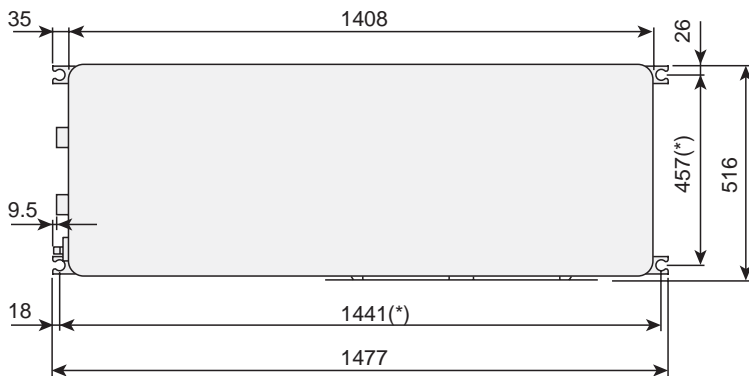

- A - Water inlet Ø1 1/2" gas
- B - Water outlet Ø1 1/2" gas
- C - Ancillary electric cables entry
- D - Power supply cables entry

(*) Location of anti-vibration mounts.
Dimensions in mm.

Dimensions - Aqu@Logic AQH size 40

Front view

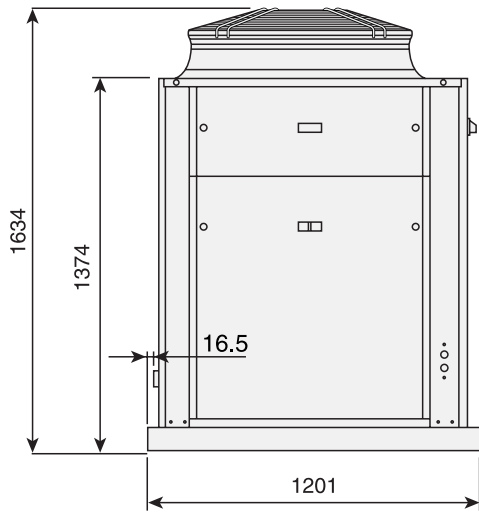

Side view

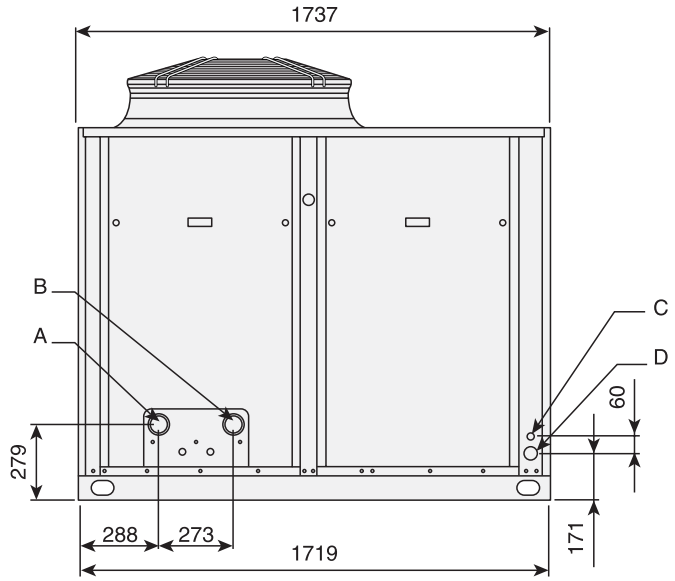

Top view

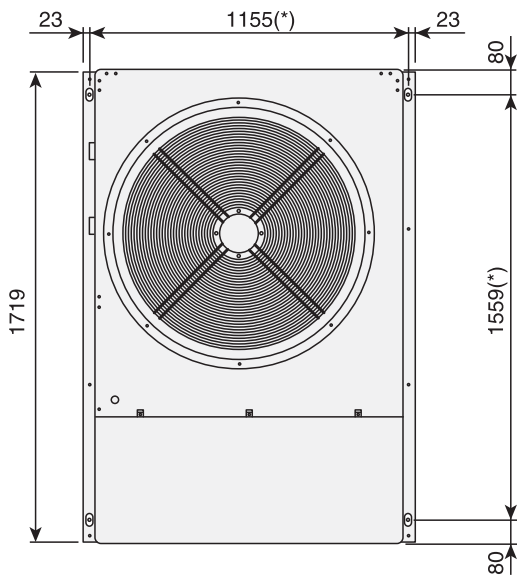

- A - Water inlet Ø2" gas
- B - Water outlet Ø2" gas
- C - Ancillary electric cables entry
- D - Power supply cables entry

(*) Location of anti-vibration mounts.
Dimensions in mm.

Dimensions - Aqu@Logic AQH sizes 50, 60, 70 and 80

Front view

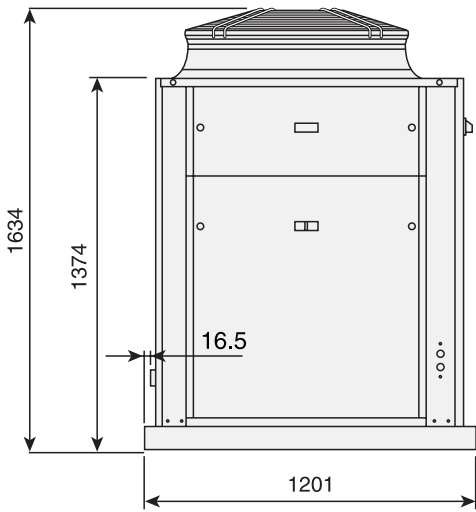

Side view

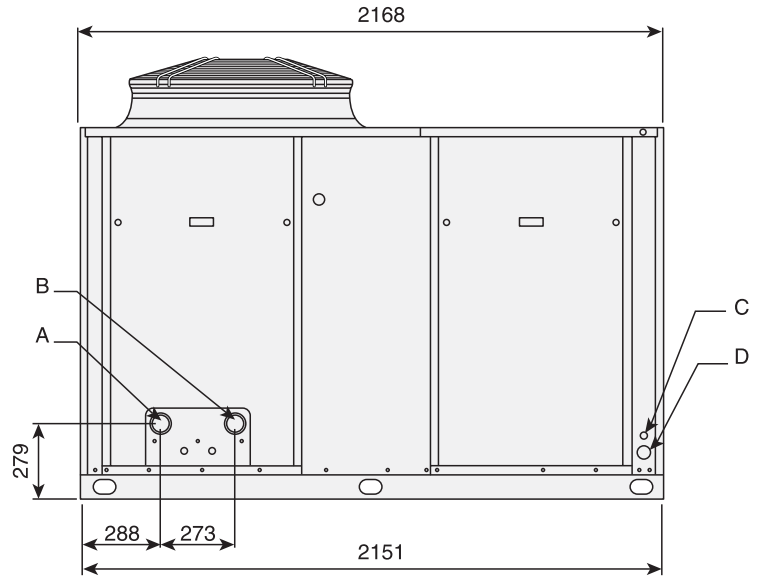

Top view

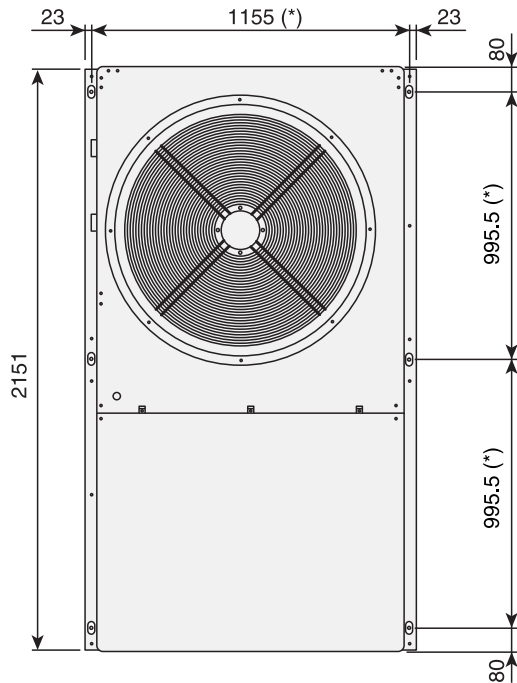

- A - Water inlet Ø2" gas
- B - Water outlet Ø2" gas
- C - Ancillary electric cables entry
- D - Power supply cables entry

(*) Location of anti-vibration mounts.
Dimensions in mm.

Dimensions - Aqu@Logic AQH size 90

Side view

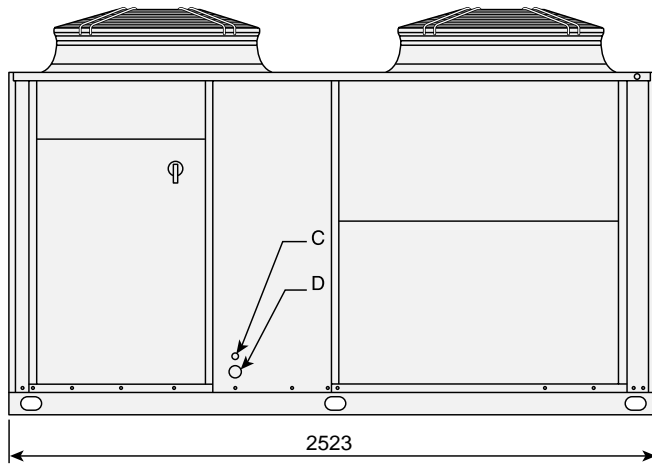

Front view

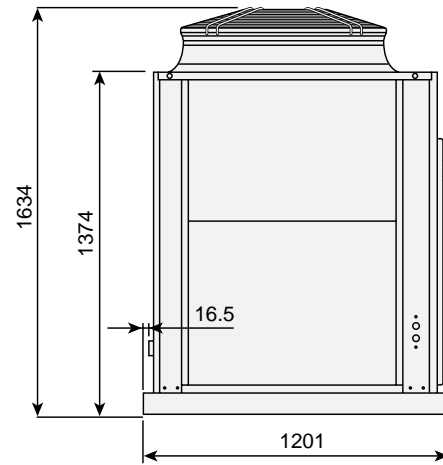

Side view

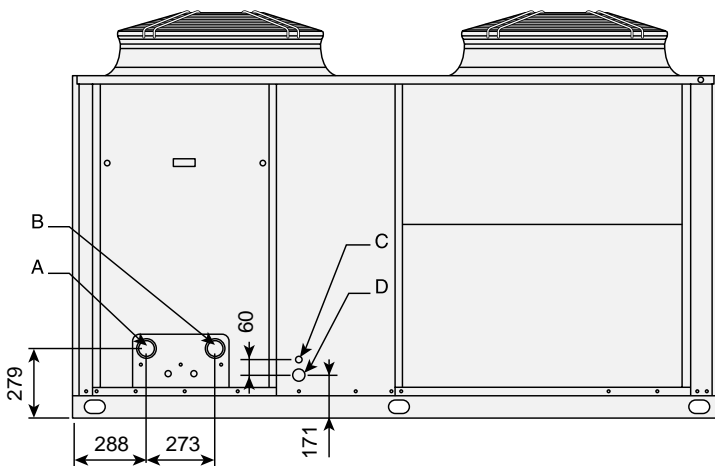

Top view

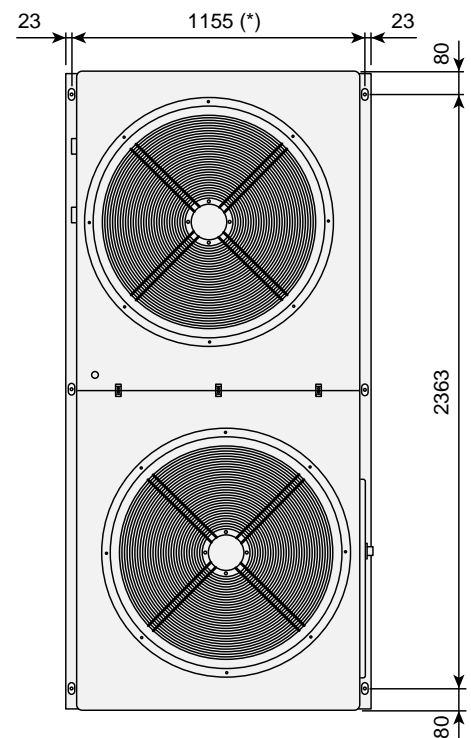

- A - Water inlet Ø2" gas
- B - Water outlet Ø2" gas
- C - Ancillary electric cables entry
- D - Power supply cables entry

(*) Location of anti-vibration mounts.
Dimensions in mm.

Dimensions - Aqu@Logic AQH sizes 100, 110, 120 and 130

Side view

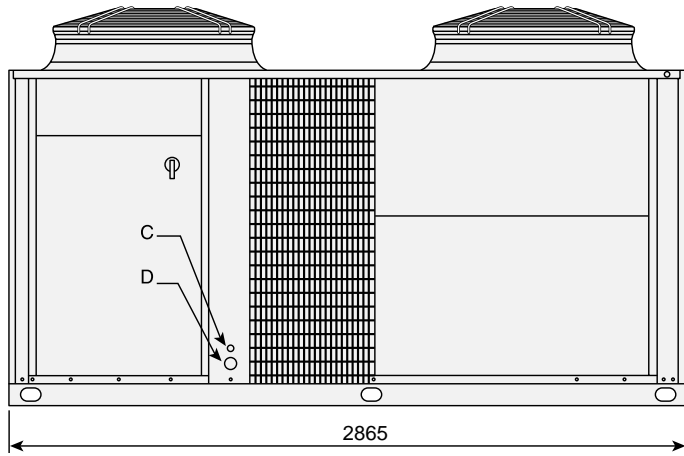

Front view

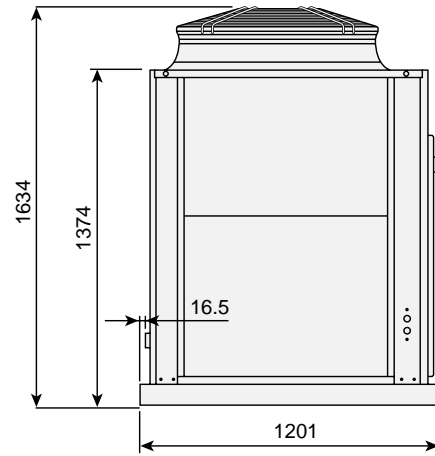

Side view

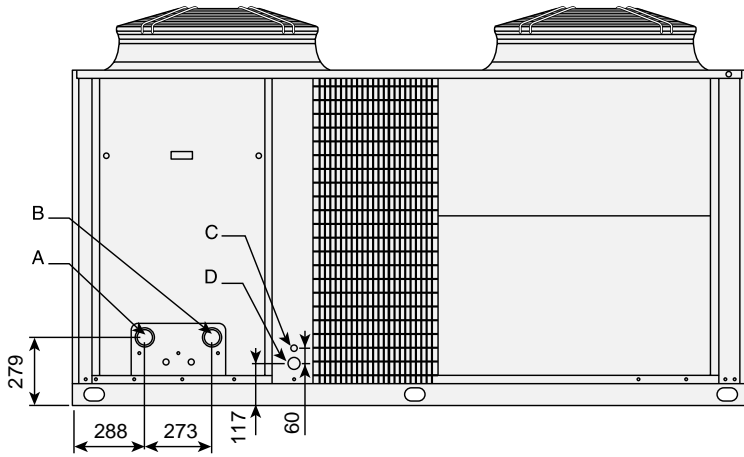

Top view

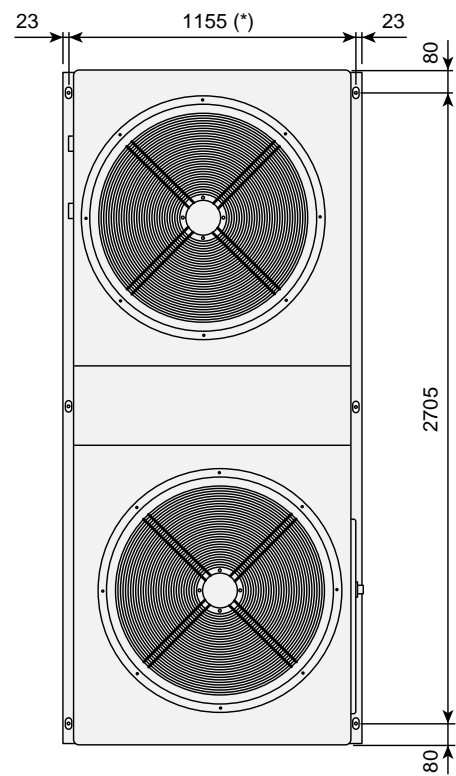

- A - Water inlet Ø2" gas
- B - Water outlet Ø2" gas
- C - Ancillary electric cables entry
- D - Power supply cables entry

(*) Location of anti-vibration mounts.
Dimensions in mm.

Minimum clearance around the unit

Aqu@Logic 20 to 35

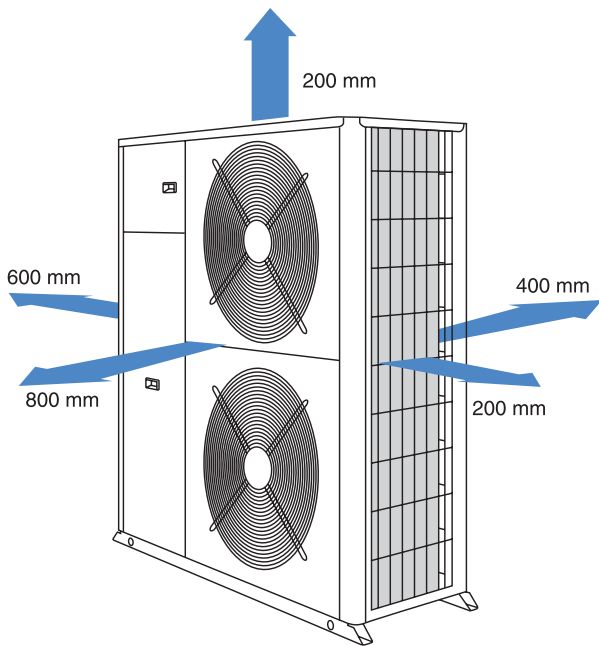

Aqu@Logic 40 to 80

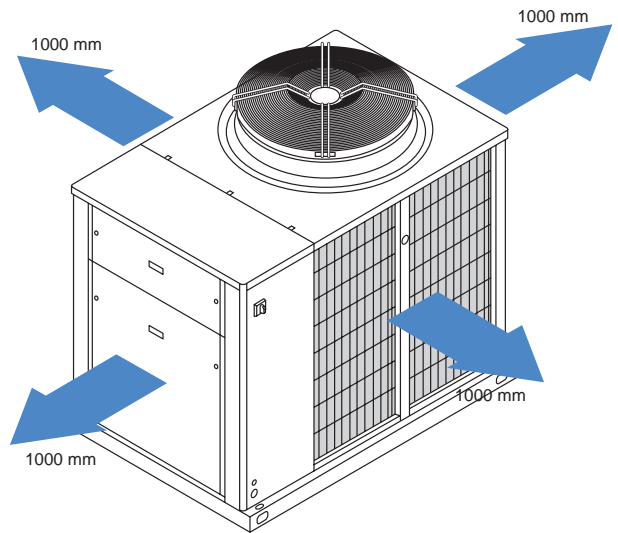

Aqu@Logic 90 to 130

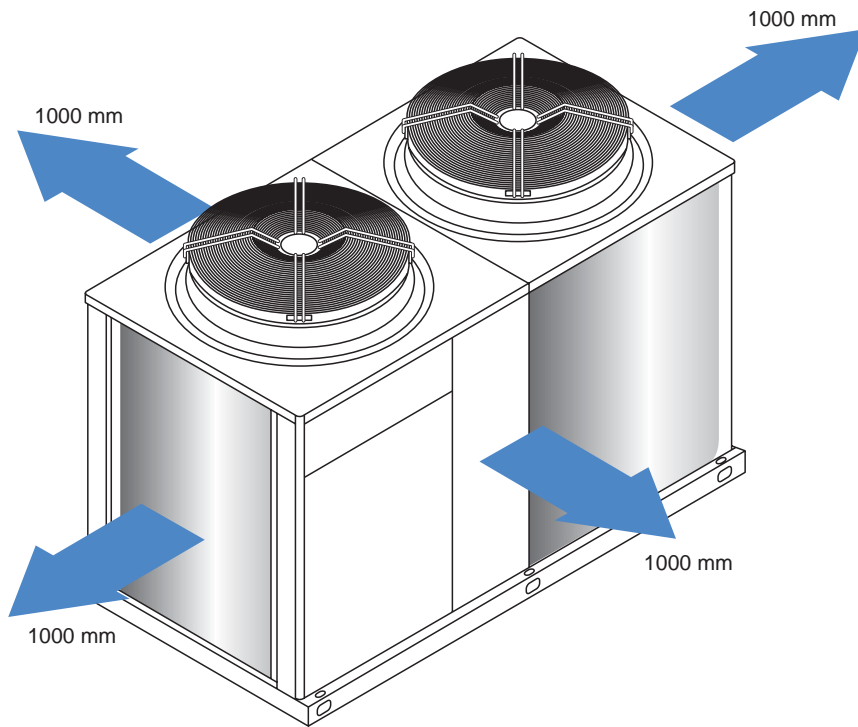

A.C.E Marketing

FRANCE :

1 bis, Avenue du 8 Mai 1945
Saint-Quentin-en-Yvelines
78284 GUYANCOURT Cedex

Tél. : +33-1 39 44 78 00

Fax : +33-1 39 44 11 55

www.airwell.com

ACE Klimatechnik GmbH

DEUTSCHLAND :

Berner Straße 43
60437 FRANKFURT/MAIN

Tel. : 0 69/507 02-0

Fax : 0 69/507 02-250

www.airwell.de

Itelco-Clima Srl

ITALY :

Via XXV Aprile, 29
20030 BARLASSINA (MI)

Tel. : 0362.6801

Fax : 0362.680281

www.itelco-clima.com

Iber elco s.a.

SPAIN :

Ciències, 71-81,
Módulo 5,
Polígono Pedrosa
08908 L'HOSPITALET DE LLOBREGAT

Tel. : 93 264 66 00

Fax : 93 335 95 38

www.iberelco.es

Airwell

As part of our ongoing product improvement programme, our products are subject to change without prior notice. Non contractual photos.



ACE

1 bis, Avenue du 8 Mai 1945
Saint-Quentin-en-Yvelines
78284 GUYANCOURT Cedex

