

► Direct Drive Compact Air Handling Units

WESPAK

1.39, 2.69 & 3.99



Engineering Data Manual
EDM WPKDD-A.2GB
Date : June 2007
Supersedes : TM WPKDD-A.1GB/02.07

Airwell

General Specifications

Introduction

Wespak direct drive compact air handling units are designed, in a modular construction, to meet the heating and air conditioning requirements of all medium-size areas.

Their low height, **only 370 mm**, facilitates easy integration within false ceilings.

- **Air flow from 500 to 4 400 m³/h in 3 different sizes.**
- **Cooling capacity from 4 to 26 kW** (supply air : 27 °C / 48 % R.H. - chilled water : 7/12 °C).
- **Heating capacity from 9 to 58 kW** (supply air : 15 °C / hot water : 90/70 °C).
- **Electrical heating capacity from 3 to 36 kW.**

Casing

Single or double skin construction manufactured from **1.2 mm thick** galvanized sheet steel (painting on external skin can be supplied as optional), with 10 mm open cell foam insulation (fire protection class M1).

Fans

Centrifugal fans with one or two impellers driven directly by a 3-speed motor, 230/1/50 Hz, insulation class F with an automatic reset internal overheat protection.

Filters

Two types of filters :

- Synthetic type with G2 or G4 efficiency. Fire class M1 at clean conditions.
- Metallic type with G1 efficiency. Fire class M0 at clean conditions.

Coils

2-row (heating coils) or 4-row coils (water or direct expansion cooling coils), with copper tubes and aluminium fins.

Coils can be fitted with optional moisture eliminator to give protection against high humidity or high air velocity.

Electric heaters

Electric heating coils with 1, 2 or 3 capacity steps, manufactured with stainless steel finned tubes and protected by a manual reset high temperature cutout switch.

Maintenance

Right hand or left hand side access to internal components. Filter access from all four sides is available as an option.

Components fixed on a sliding mounting rail for easy maintenance (except for the cooling coil in vertical arrangement).

Arrangements

- Horizontal (for floor or ceiling installations) or vertical arrangements.
- 10 basic sections to form, by compatible combination of these sections, a large number of double section arrangements satisfying all applications.
- 6 compact single section arrangements.

Options and accessories

Several options and accessories are available : mixing boxes, external filter section, double skin panel, electromechanical control systems, etc. Please refer to the corresponding section to see the full list of options and accessories.



Unit with optional external shut-off damper



Unit with optional discharge plenum

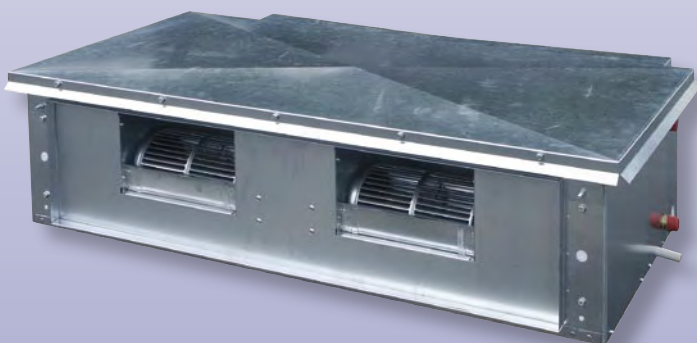



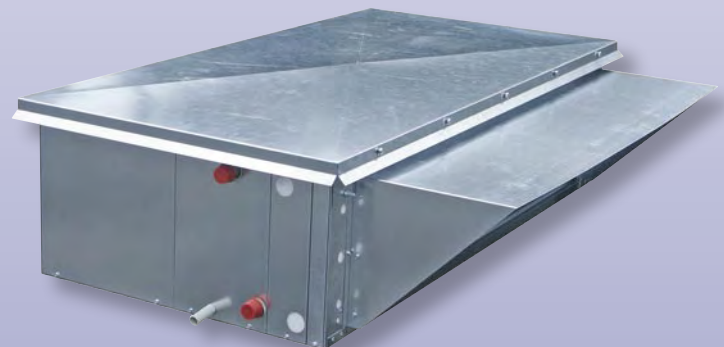

Unit with optional roof

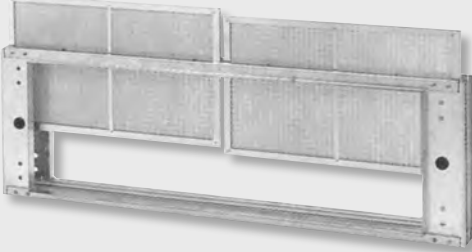
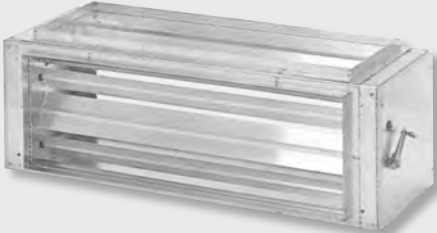

Unit with optional roof and weather hood

Description of Basic Sections

<p>Fan section with fan and drive motor. Can be equipped with filter (synthetic type with G2 efficiency or metallic type with G1 efficiency).</p>	
<p>Coil section which can take a choice of cooling coil (chilled water or direct expansion), moisture eliminator, heating coil (hot water or electric) and filter (synthetic type with G2 efficiency or metallic type with G1 efficiency).</p>	
<p>For horizontal air flow option with heat exchangers upstream of fan (outlet temperature below 50 °C), all components can be fitted within the same section.</p>	
<p>Separate bolt-on filter section can be equipped with any of the different medias (G1, G2 or G4 efficiency) and can be easily serviced from all four sides.</p>	
<p>Mixing section, suitable for motorised operation, including two or three dampers with opposed acting blades allowing proportional mix of fresh, return and exhaust air.</p>	
<p>Air-to-air plate heat exchanger allowing heat recovery up to 63 % of exhaust air energy. Equipped with metallic filters on both fresh and exhaust air sides.</p>	

Unit Coding

WESPAK **2.69** **H** **M** **G** **49** **A**

Position: Air outlet A - B - C } For two-section air handling units only
Air inlet D - E }

Identification of basic sections * see notes

Connection side: **G**: Left } When viewing the unit from above, in the direction of air flow
D: Right }

Structure: **M**: Multi-section unit
P: Single section unit

Arrangement: **H**: Horizontal
V: Vertical

Unit size: **1.39**: 1 impeller
2.69: 2 impellers
3.99: 2 impellers

Arrangements from inlet to outlet

*** Notes :**

- Double-digit references are given for two-section units only.
- Cooling coils : chilled water or direct expansion.
- Heating coils : hot water or electric.

Coding of Basic Sections

Section 0	Section 1	Section 2	Section 3	Section 4
Section 5	Section 6	Section 7	Section 8	Section 9

Air Inlet and Outlet Arrangement

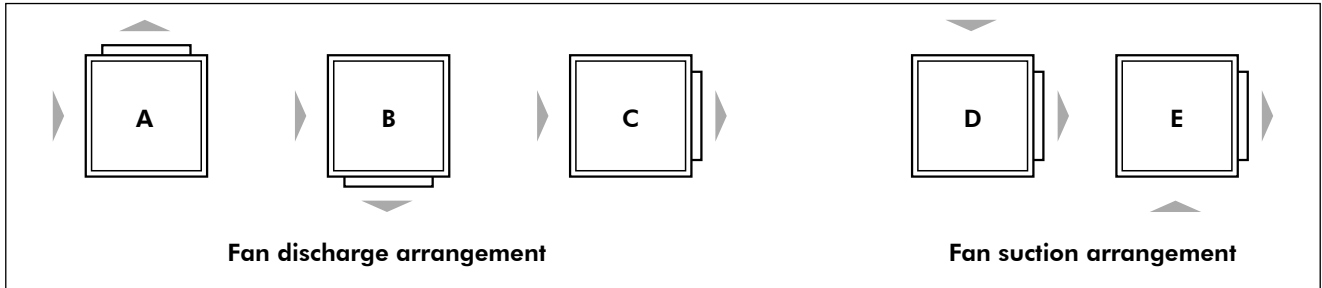

- ✓ A, B, D and E arrangement can only be obtained with the use of a separate fan section n° 9.
- ✓ No possibility to have an integrated filter in fan section n° 9.
- ✓ Single section WESPAK unit does not allow a 90° in/out air flow.

Double Section Assembly

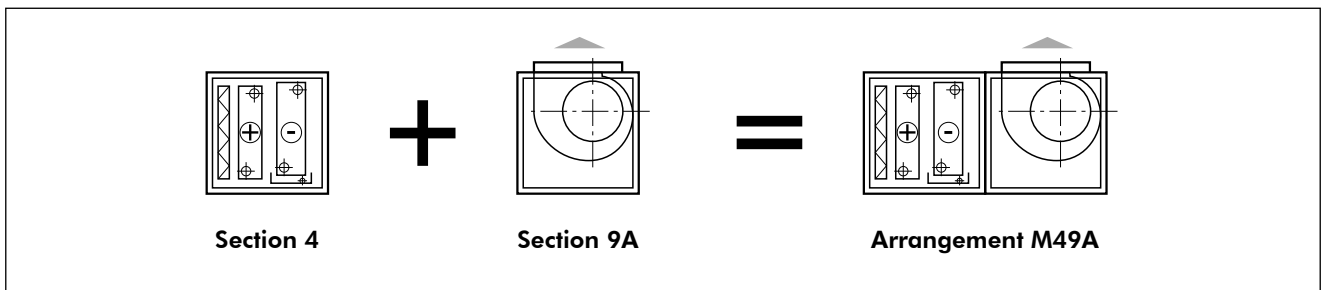

- ✓ Unit including two sections are always referenced by a double digit reference and a letter, (e.g. M49).
- ✓ Single section units are identified by only one digit reference without any letter defining the air in / out flow direction.
- ✓ Coding of single section units : pages 6 and 8.
- ✓ All units with double sections are shipped bolted together.
- ✓ Coding of all arrangements : page 6 to 8.

Assembly Precautions

Non compatible arrangements

- ✓ Ceiling mounted units arrangements :

~~84 - 85 - 86 - 87~~
~~94 - 95 - 96 - 97~~

- ✓ Wall mounted units arrangements :

~~81 - 82 - 83 - 84 - 85 - 86 - 87~~
~~91 - 92 - 93 - 94 - 95 - 96 - 97~~

Prohibited applications

- ✓ Electric heating coil **BE3** upstream of fan.
- ✓ Heating coil upstream of fan when off-coil temperature exceeds **50 °C**.
- ✓ Electric heating coil within **VM49** section.

Unsuitable arrangements

- ✓ M39 - M59 - M83 - M93 arrangements, if 100 % fresh air of winter season is flowing directly on chilled water coil (without glycol solution) located upstream of heating coil.
- ✓ Use of fan section (arrangement 9) when the external resistance is below 50 Pa.

Recommendations

- ✓ Use of moisture eliminator in case cooling coil face air velocity above 2.7 m/s (see curve page 13).
- ✓ Use of external filter on arrangements : HM 90 to 93 - VP 1 - VM 19 - VM 39 - VM 90.
- ✓ Use of metallic filter in the vicinity of electric heating coil.

Mounting Possibilities

SINGLE SECTION UNITS (HORIZONTAL)		
Arrangement HP0	Arrangement HP1	Arrangement HP2
Arrangement HP3	Arrangement HP4	Arrangement HP5
Arrangement HP6		Arrangement HP7

See page 20 for overall dimensions and page 26 for weights.

FAN SECTION		
Arrangement HM8	Arrangement HM9A	Arrangement HM9D
Arrangement VM8	Arrangement VM9A	Arrangement VM9D

See page 20 for overall dimensions and page 26 for weights.

Mounting Possibilities (continued)

DOUBLE SECTION UNITS (HORIZONTAL)		
<p>Arrangement HM69A</p>	<p>Arrangement HM79B</p>	<p>Arrangement HM49A</p>
<p>Arrangement HM80</p>	<p>Arrangement HM81</p>	<p>Arrangement HM59B</p>
<p>Arrangement HM90D</p>	<p>Arrangement HM91D</p>	<p>Arrangement HM82</p>
<p>Arrangement HM93D</p>	<p>Arrangement HM92E</p>	<p>Arrangement HM83</p>

See page 20 for overall dimensions and page 26 for weights.









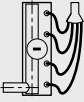

Mounting Possibilities (continued)

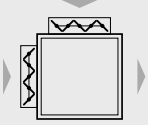

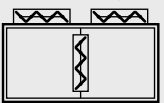
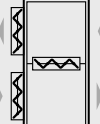



SINGLE SECTION UNITS (VERTICAL)		
Arrangement VP6	Arrangement VP7	Arrangement VP1

DOUBLE SECTION UNITS (VERTICAL)			
Arrangement VM69A	Arrangement VM80	Arrangement VM90E	Arrangement VM79A
Arrangement VM59A	Arrangement VM49A	Arrangement VM39B	Arrangement VM19B

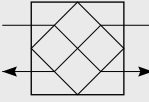
See page 20 for overall dimensions and page 26 for weights.

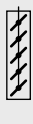
Options and Accessories

	6-row water cooling coil	BF6
	Direct expansion coil	BD
	1 stage	BE1
	2 stages	BE2
	3 stages	BE3
	2-way mixing box with face and top dampers	MD1
	2-way mixing box with top and bottom dampers	MD2
	In line 3-way mixing box with top dampers	MD3
	Superposed 3-way mixing box with top dampers	MD3
	Fan 3-speed switch	CMVM
	Remote control including summer/winter change-over, room thermostat, on/off, and fan 3-speed switch. Valve and fan cycling action.	TRM-FA
	Remote control including summer/winter change-over, room thermostat, on/off, and fan 3-speed switch. Valve cycling only action.	TRM-VP
	Double skin casing panel	DP
	RAL 9010 painting	PT

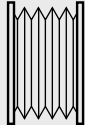
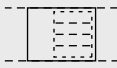
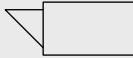
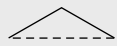
	Moisture eliminator	EL
	Air-to-air heat recuperator	RP
	12 mm metallic filter with G1 efficiency replacing standard filter	FM1
	12 mm metallic, G1 efficiency	FA1
	12 mm synthetic, G2 efficiency	FA2
	50 mm synthetic, G4 efficiency	FA4
	Parallel blade shut-off damper	AG
	Two-way discharge air plenum	PLE
	90° discharge air plenum	R
	Inlet duct collar	CA
	Flexible connection for inlet side, outlet side or mixing boxes	M
	Silencer	PAS
	Weather hood	AP
	Roof	TO

Quick Selection - Air flow/External Static Pressure

Fan section incl. G2 filter

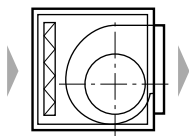

External static pressure (Pa)										
Air flow (m ³ /h)		500	600	700	900	1100	1300	1500	1700	
1.39	LS	234	165	56	-	-	-	-	-	-
	MS	-	-	-	283	238	172	-	-	-
	HS	-	-	-	-	-	270	240	200	-
Air flow (m ³ /h)		700	1000	1300	1600	1900	2200	2500	2800	3100
2.69	LS	-	203	168	114	30	-	-	-	-
	MS	-	-	260	234	196	138	55	-	-
	HS	-	-	-	-	-	240	205	162	100
Air flow (m ³ /h)		1600	2000	2400	2800	3200	3600	4000	4400	4800
3.99	LS	-	279	240	189	108	-	-	-	-
	MS	-	-	276	237	186	116	12	-	-
	HS	-	-	-	271	238	198	148	79	-

Fan section incl. G2 filter and heating coil

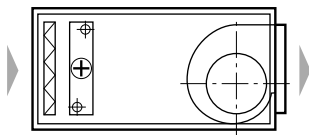

External static pressure (Pa)										
Air flow (m ³ /h)		500	600	700	900	1100	1300	1500	1700	
1.39	LS	226	156	46	-	-	-	-	-	-
	MS	-	-	-	271	222	150	-	-	-
	HS	-	-	-	-	-	248	213	166	-
Air flow (m ³ /h)		700	1000	1300	1600	1900	2200	2500	2800	3100
2.69	LS	-	195	158	100	12	-	-	-	-
	MS	-	-	250	220	178	115	27	-	-
	HS	-	-	-	-	-	217	177	126	58
Air flow (m ³ /h)		1600	2000	2400	2800	3200	3600	4000	4400	4800
3.99	LS	-	267	224	171	82	-	-	-	-
	MS	-	-	260	219	160	84	-	-	-
	HS	-	-	-	253	212	166	110	33	-

For other arrangements determine the fan speed and the characteristics from charts of component air pressure drops and fan curves (pages 12 and 13).

Quick Selection - Air flow/External Static Pressure (continued)

Fan section incl. G2 filter and cooling coil

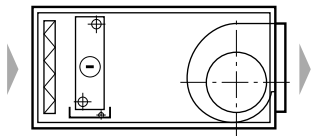

		External static pressure (Pa)								
Air flow (m ³ /h)		500	600	700	900	1100	1300	1500	1700	
1.39	LS	224	153	40	-	-	-	-	-	-
	MS	-	-	-	257	201	120	-	-	-
	HS	-	-	-	-	-	218	174	120	-
Air flow (m ³ /h)		700	1000	1300	1600	1900	2200	2500	2800	3100
2.69	LS	-	190	148	84	-	-	-	-	-
	MS	-	-	240	204	154	87	-	-	-
	HS	-	-	-	-	-	189	137	78	-
Air flow (m ³ /h)		1600	2000	2400	2800	3200	3600	4000	4400	4800
3.99	LS	-	250	203	137	46	-	-	-	-
	MS	-	-	239	185	124	44	-	-	-
	HS	-	-	-	219	176	126	26	-	-

Fan section incl. G2 filter, heating coil and cooling coil

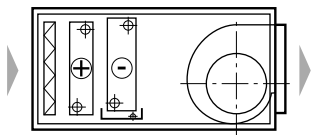

		External static pressure (Pa)								
Air flow (m ³ /h)		500	600	700	900	1100	1300	1500	1700	
1.39	LS	216	144	30	-	-	-	-	-	-
	MS	-	-	-	245	185	98	-	-	-
	HS	-	-	-	-	-	196	147	86	-
Air flow (m ³ /h)		700	1000	1300	1600	1900	2200	2500	2800	3100
2.69	LS	-	182	138	70	-	-	-	-	-
	MS	-	-	230	190	136	64	-	-	-
	HS	-	-	-	-	-	166	109	42	-
Air flow (m ³ /h)		1600	2000	2400	2800	3200	3600	4000	4400	4800
3.99	LS	-	238	187	119	20	-	-	-	-
	MS	-	-	223	167	98	12	-	-	-
	HS	-	-	-	201	150	94	-	-	-

For other arrangements determine the fan speed and the characteristics from charts of component air pressure drops and fan curves (pages 12 and 13).

Fan Performance Curves

Wespak 1.39

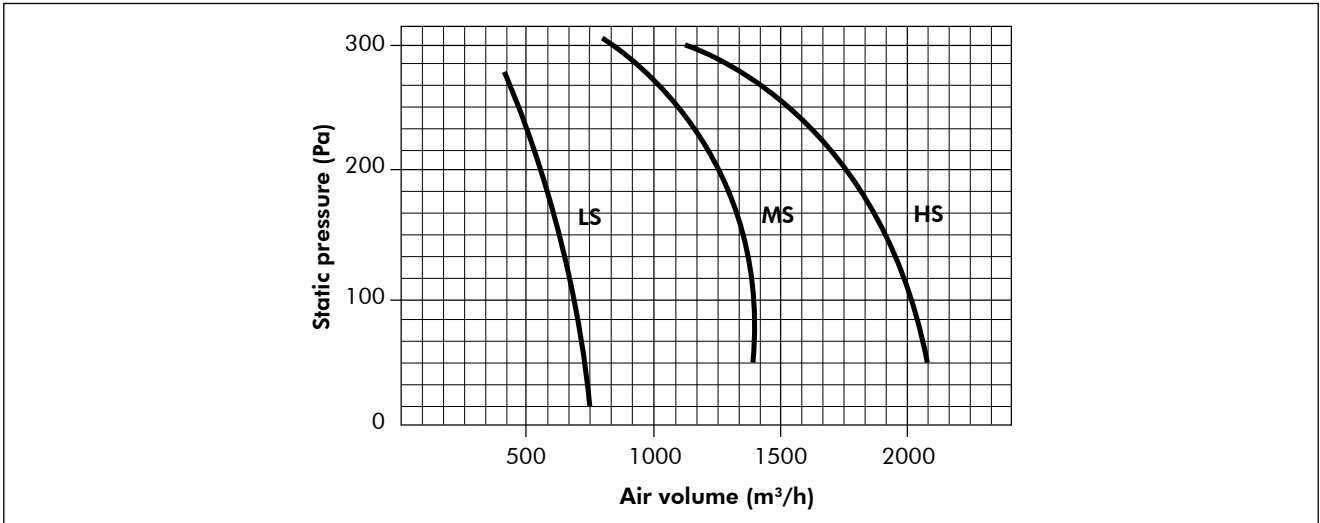

Wespak 2.69

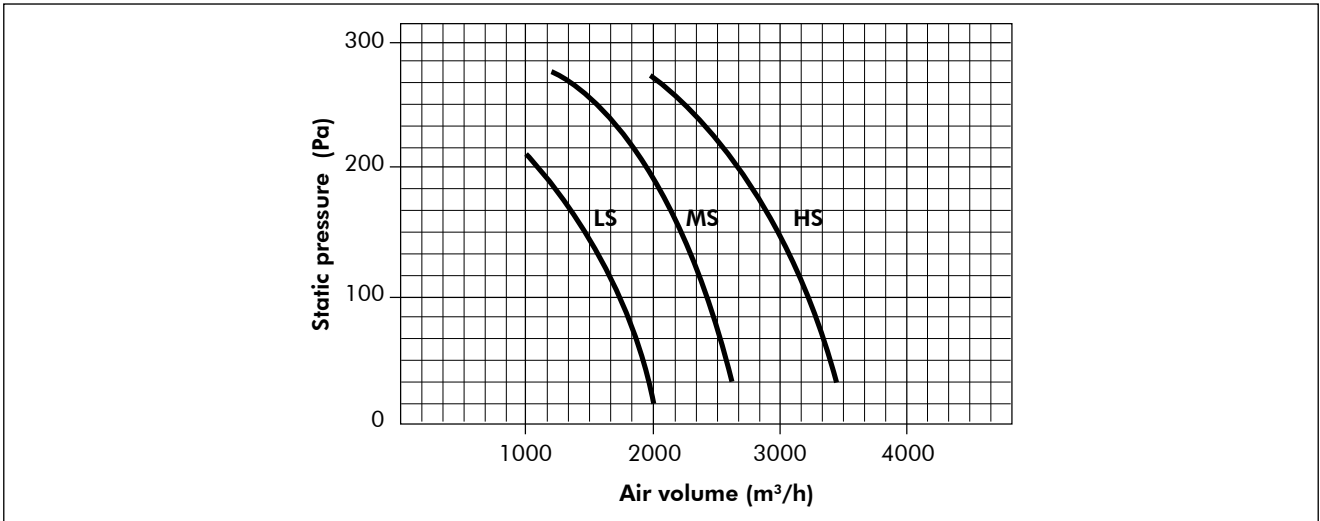

Wespak 3.99

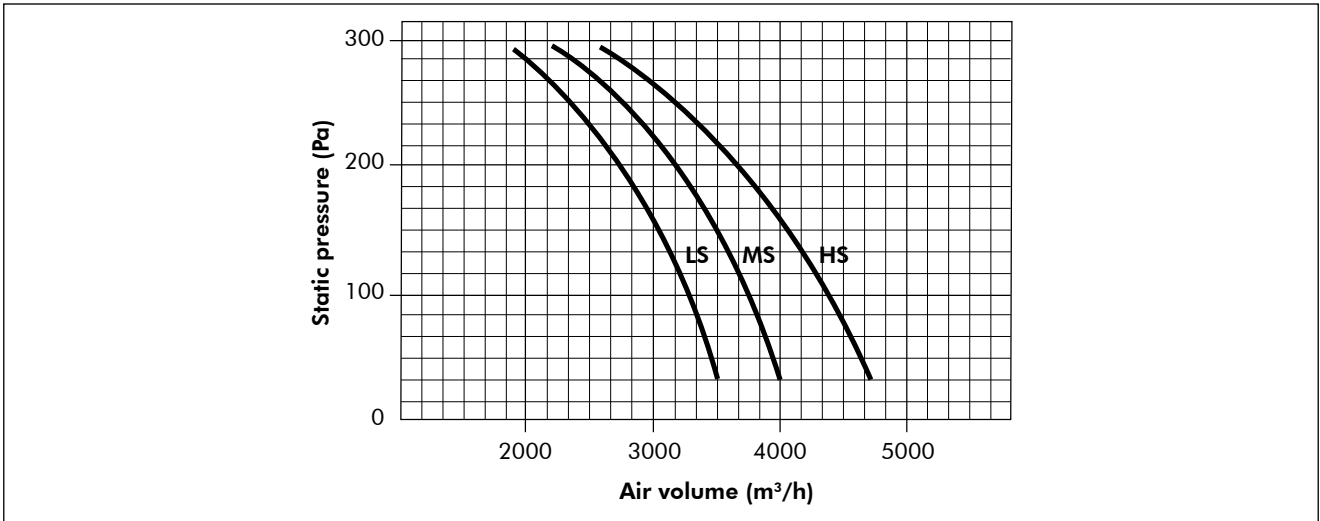

Note : Indicated static pressures are given for fan motor assembly alone. Deduct pressure losses of each additional element to determine the external static pressure.

Air Pressure Drop Curves

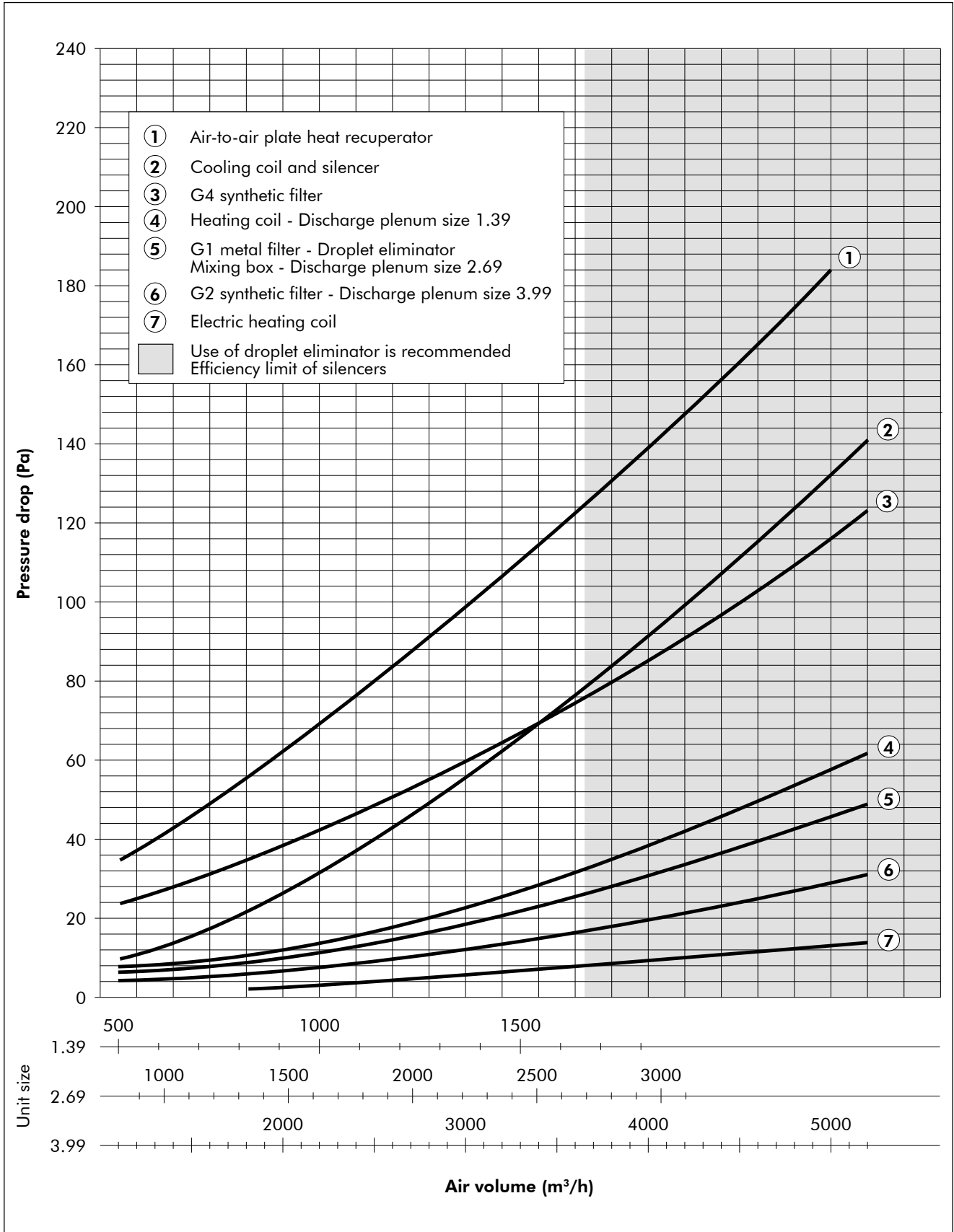

Heating Capacity

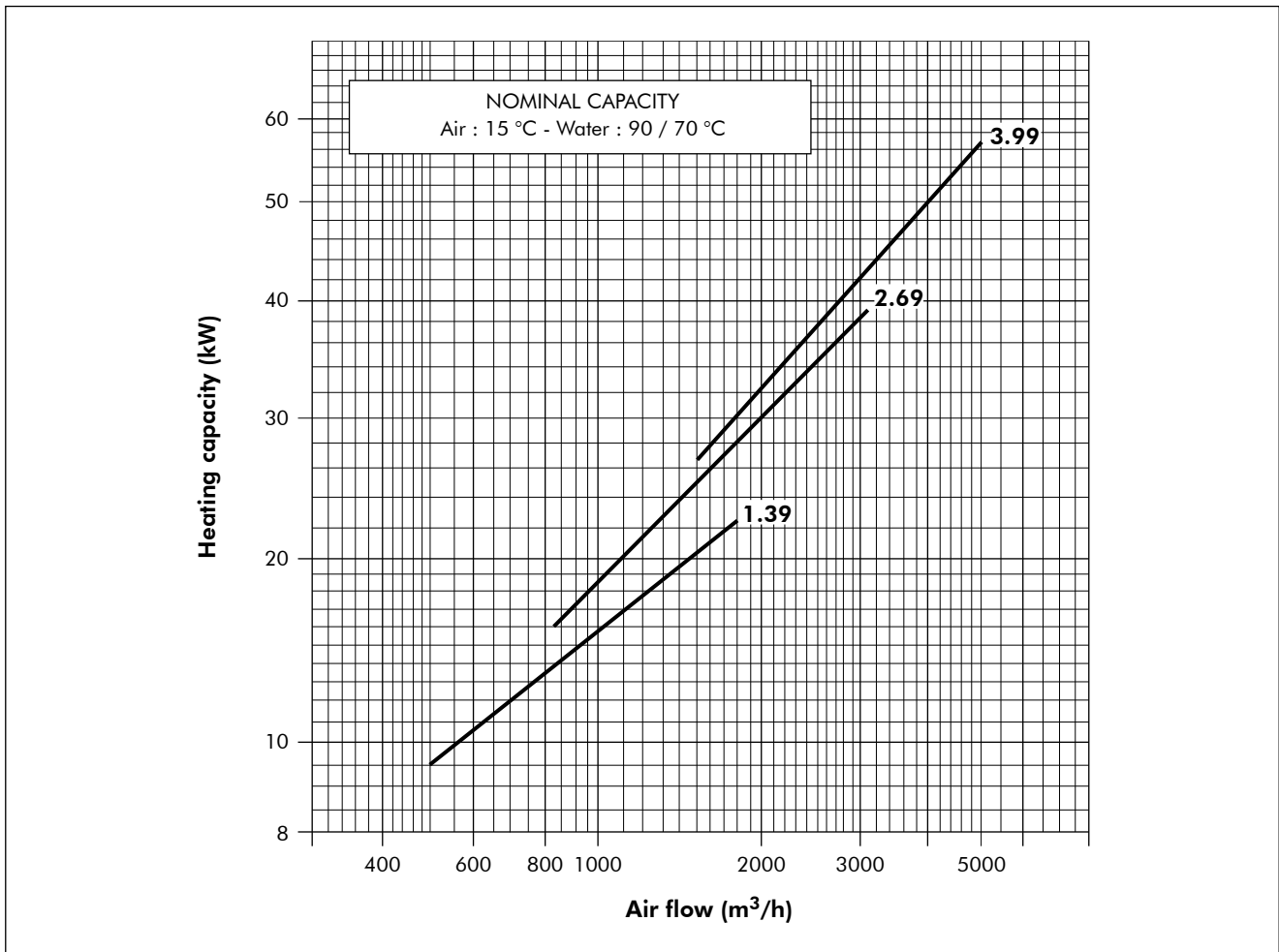

Correction factors for different operating conditions

Water temperatures (°C)	Inlet air temperatures (°C)							
	20	15	10	5	0	-5	-10	-15
90 / 70	0.91	1.00	1.09	1.19	1.28	1.38	1.49	1.59
60 / 50	0.52	0.61	0.70	0.79	0.88	0.97	1.07	1.17
45 / 37	0.30	0.39	0.47	0.56	0.65	0.74	0.83	0.93

Example of selection

Given : Capacity of a 2.69 unit, air flow : 2000 m³/h, air temp. : - 5 °C, water temp. : 90/70 °C.

- ✓ Read on chart above the nominal capacity of the 2.69 unit (30 KW). The multiplier for the required operating conditions is 1.38 which gives an actual capacity of 41.4 kW.
- ✓ Calculate the water flow : $41.4 \times 0.86 / (90 - 70) = 1.78 \text{ m}^3/\text{h}$.
- ✓ Read pressure drop on chart page 17.
- ✓ Calculate outlet air temperature : $- 5 + (41.4 \times 1000) / (2000 \times 0.34) = 55.9 \text{ °C}$.
- ✓ As this temperature is higher than 50 °C, use the heating coil downstream of fan.

Cooling Capacity

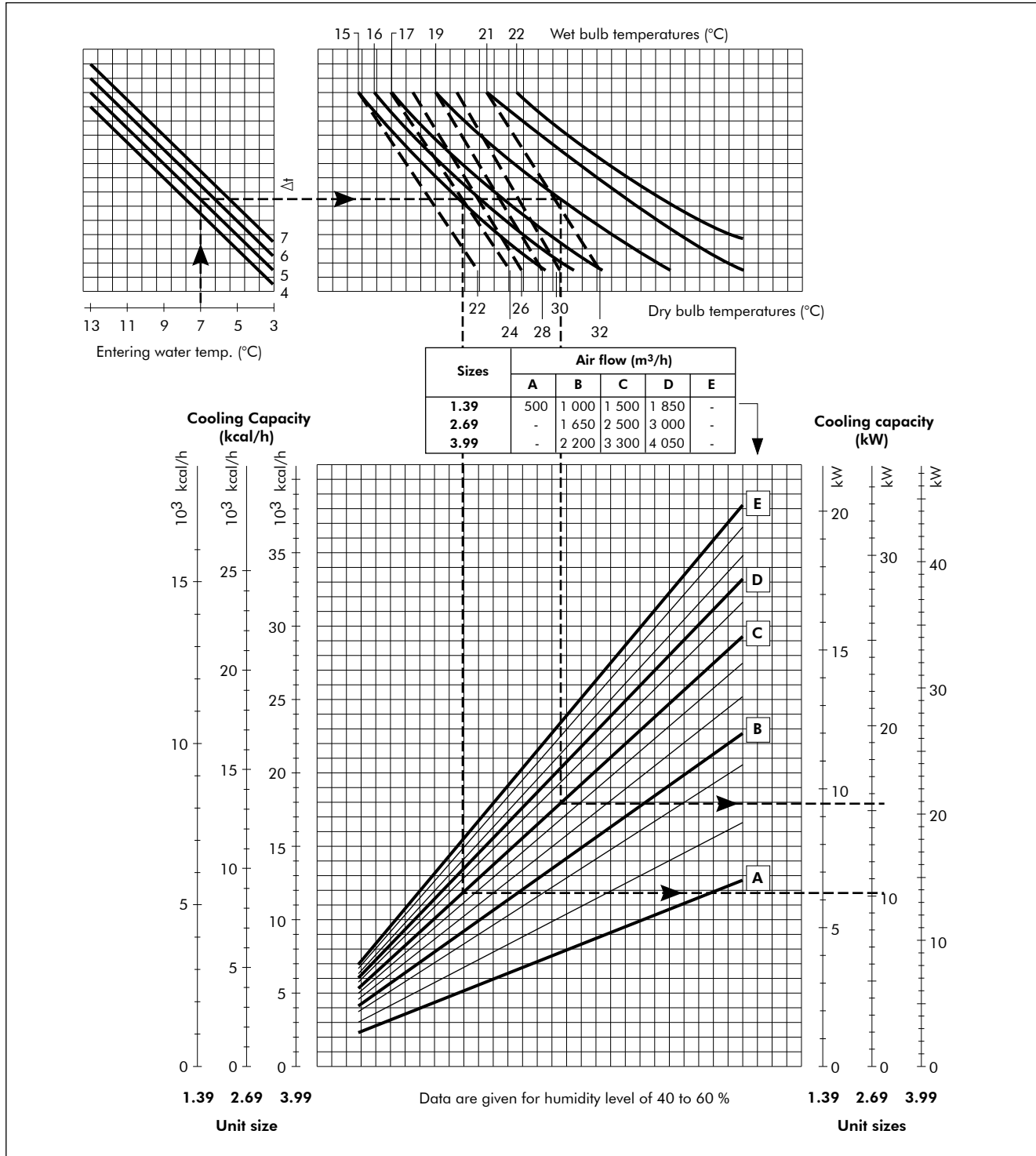

Example of selection

Given : Capacity of a 2.69 unit, air flow : 2500 m³/h, dry bulb temperature : 24 °C, wet bulb temperature : 19 °C, water : 7/12 °C.

- ✓ Draw a vertical line upward from the inlet water temperature (7 °C) to the curve of $\Delta t = 5$ °C.
- ✓ Draw a horizontal line from this point, and then draw 2 verticals downward from the crossing points of both curves DB 24 °C and WB 19 °C to the curve C corresponding to the required air flow (2500 m³/h).
- ✓ At the side scale, read the total capacity (15420 W) and the sensible capacity (10285 W).
- ✓ Calculate the water flow : $15420 \times 0.86 / 1000 / (12 - 7) = 2.65$ m³/h.
- ✓ Read pressure drop on chart page 17.

Air-to-Air Plate Heat Recuperator

Recuperator nominal efficiency curve

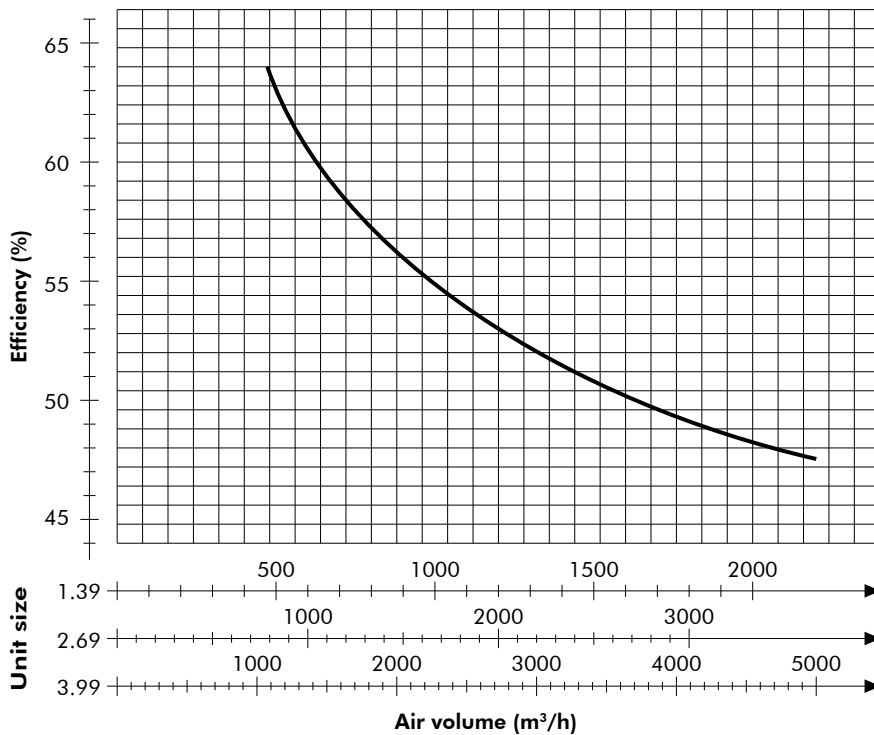

Multiplier

FA/EA	Correction Factors
0.50	1.25
0.60	1.20
0.70	1.15
0.80	1.10
0.90	1.05
1.00	1.00
1.10	0.95
1.20	0.90
1.30	0.85
1.40	0.80
1.50	0.75
1.60	0.70
1.70	0.65
1.80	0.60
1.90	0.55
2.00	0.50

FA : Fresh air volume
EA : Exhaust air volume

Freezing limit temperatures

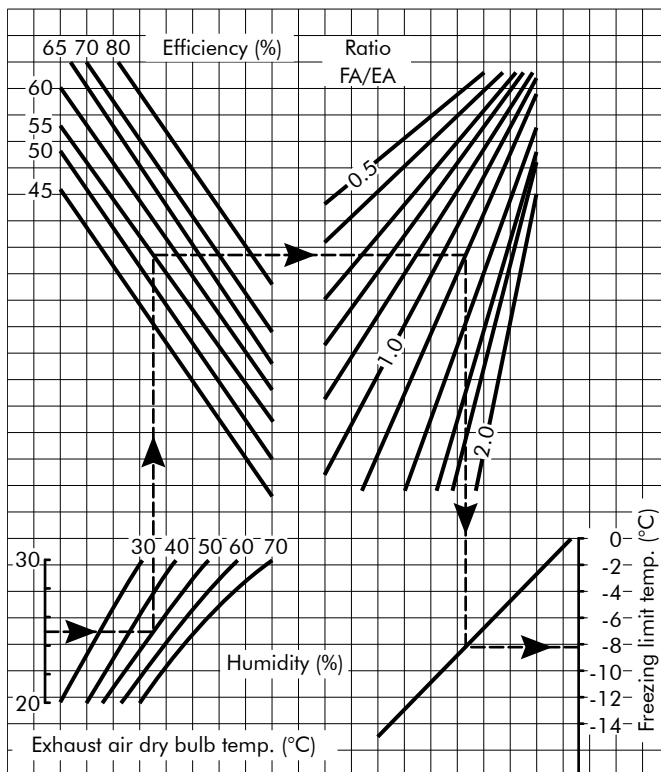

Example of selection

- ✓ Determine the Wespak size according to air flow and pressure drop of the recuperator.
- ✓ Read nominal efficiency on curve above.
- ✓ Determine the actual efficiency by using the correction multiplier Fresh air volume/Exhaust air volume (corrected efficiency = nominal efficiency x correction factor).
- ✓ Check the freezing limit temperature according to the dry bulb exhaust air temperature, the corrected efficiency and the ratio Fresh air volume/Exhaust air volume.
- ✓ If :
 - LAT** : Leaving Air Temperature
 - EF** : Corrected efficiency
 - EAT** : Exhaust air temperature
 - FAT** : Fresh Air Temperature after eventual heating

We have : $LAT = EF \times (EAT - FAT) + FAT$

Technical Specifications

Cooling coils

Sizes	1.39	2.69	3.99
Rows	4	4	4
Fin spacing (*)	2.1	2.1	2.1
Front area (m ²)	0.19	0.3	0.41
Water connections	26/34 male threaded		
Water volume (l)	2.3	3.4	4.5

Heating coils

Sizes	1.39	2.69	3.99
Rows	2	2	2
Fin spacing (*)	2.1	2.1	2.1
Front area (m ²)	0.19	0.3	0.41
Water connections	26/34 male threaded		
Water volume (l)	1.3	1.9	2.4

(*) For high dehumidification, use 3.2 mm fin spacing option (consult factory).

Water pressure drops

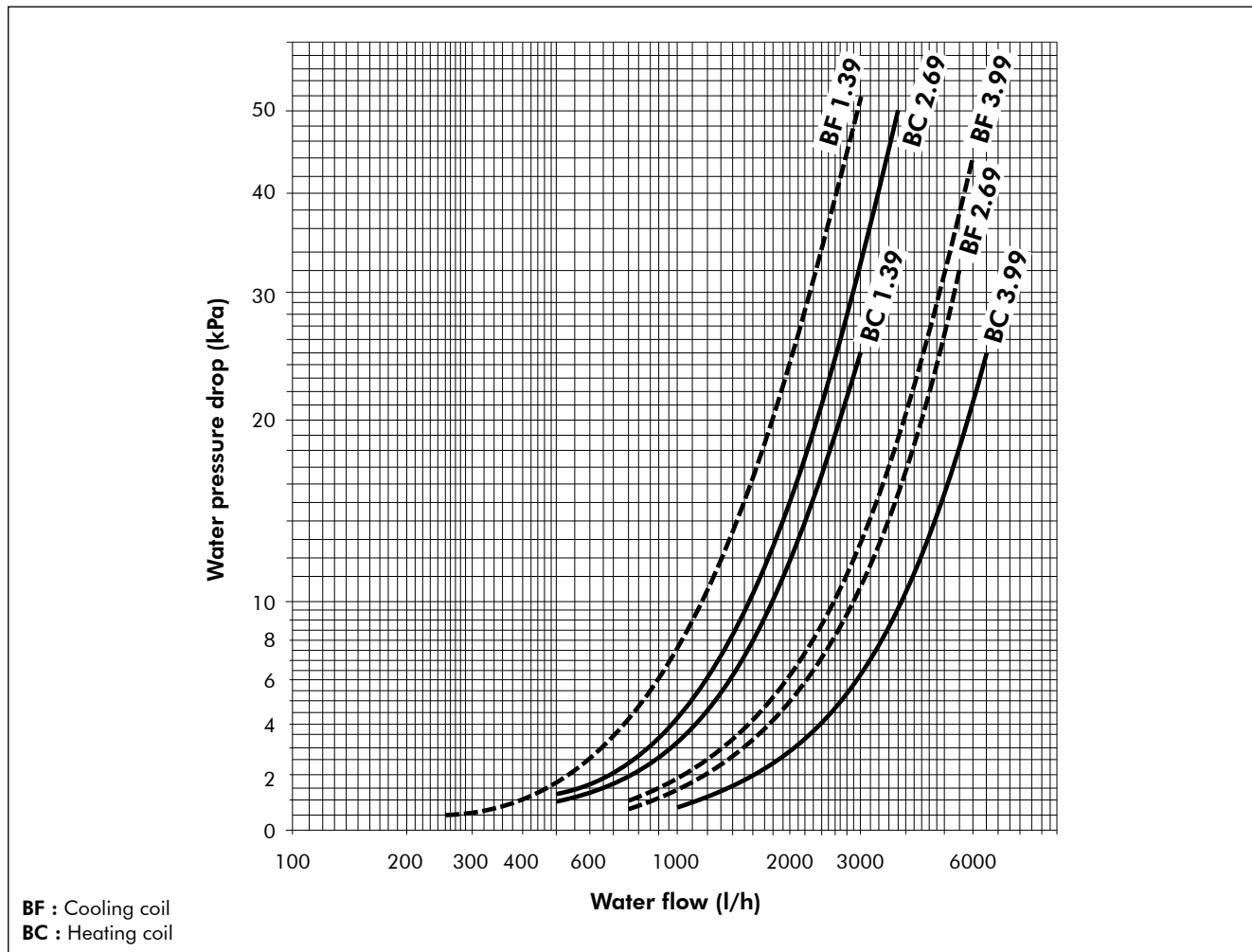

Electric heating coils

Sizes	1.39			2.69			3.99		
Coils	BE1	BE2	BE3 *	BE1	BE2	BE3 *	BE1	BE2	BE3 *
Capacity (kW)	3	6	9	6	12	18	12	24	36
Voltage	400 V / 3 / 50 Hz - (230 V / 3 / 50 Hz optional)								
Number of stages	1	2	3	1	2	3	1	2	3

(*) BE3 to be used on fan discharge only.

Technical Specifications (continued)

Fan motor

Sizes	Motor absorbed power * (W)	Voltage	Number of wheels	Max. running current (A) *		
				LS	MS	HS
1.39	740	220-240/1/50	1	1.4	2.4	3.3
2.69	960	220-240/1/50	2	2.02	3.0	4.22
3.99	1185	220-240/1/50	2	3.3	3.95	5.01

* Characteristics in accordance with the maximum air flow given by fan performance curves.

Sound pressure levels

Sizes		Sound pressure levels (dB)								Global (dBA)
		63	125	250	500	1000	2000	4000	8000	
1.39	LS	34.60	35.80	31.30	26.80	19.90	20.10	15.30	10.80	29.00
	MS	48.30	51.60	41.60	39.40	35.40	29.70	17.60	11.80	41.70
	HS	49.00	55.10	46.70	39.50	39.30	36.10	25.70	12.70	45.20
2.69	LS	41.90	45.80	35.60	41.60	28.60	23.70	17.10	12.10	39.80
	MS	45.60	51.30	39.90	42.80	34.50	29.70	20.10	12.80	42.60
	HS	49.30	54.60	45.90	44.10	40.00	36.20	27.40	13.30	46.20
3.99	LS	46.00	50.00	46.10	43.00	40.10	33.60	34.10	31.80	45.50
	MS	49.30	54.20	50.40	47.30	42.50	38.10	36.30	35.30	49.10
	HS	51.30	58.10	53.40	49.40	44.30	42.20	37.40	37.10	51.70

Sound pressure levels measured in free field, at 3 meter below the unit (Arrangement with filter, heating and cooling coils directly connected to a 3 meter discharge duct).

Air throw with discharge plenum

Throw (m)	Air flow (m ³ /h)		
	1.39	2.69	3.99
6	700	1000	-
8	950	1400	1800
10	1200	1700	2250
12	1400	2000	2700
14	1700	2500	3200
16	-	2750	3500
18	-	3000	4000
20	-	3250	4250

- ✓ Throw is valid for a homogeneous temperature air flow with wall effect and a 60° air diffusion angle.
- ✓ Throw is reduced by 30 % in case of an installation without wall effect.
- ✓ Throw is increased by about 80 % for a 20° air diffusion angle (straight blades).

Filter dimensions

Sizes	1.39	2.69	3.99
Quantity	1	2	2
Height (mm)	335	335	335
Width (mm)	737	562	737

Water Connections (in mm)

Horizontal units

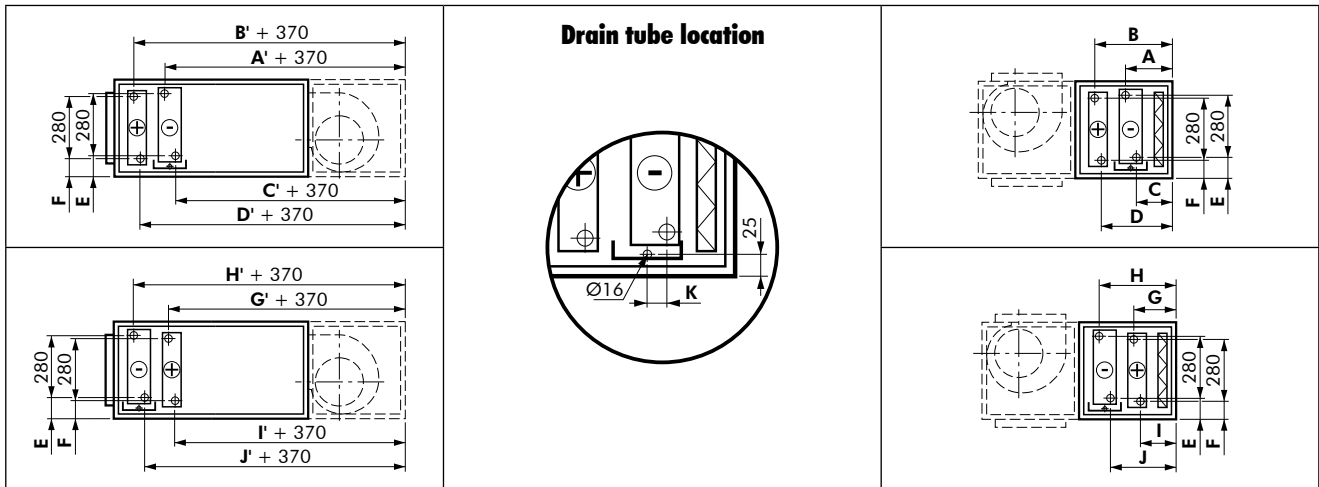

Vertical units

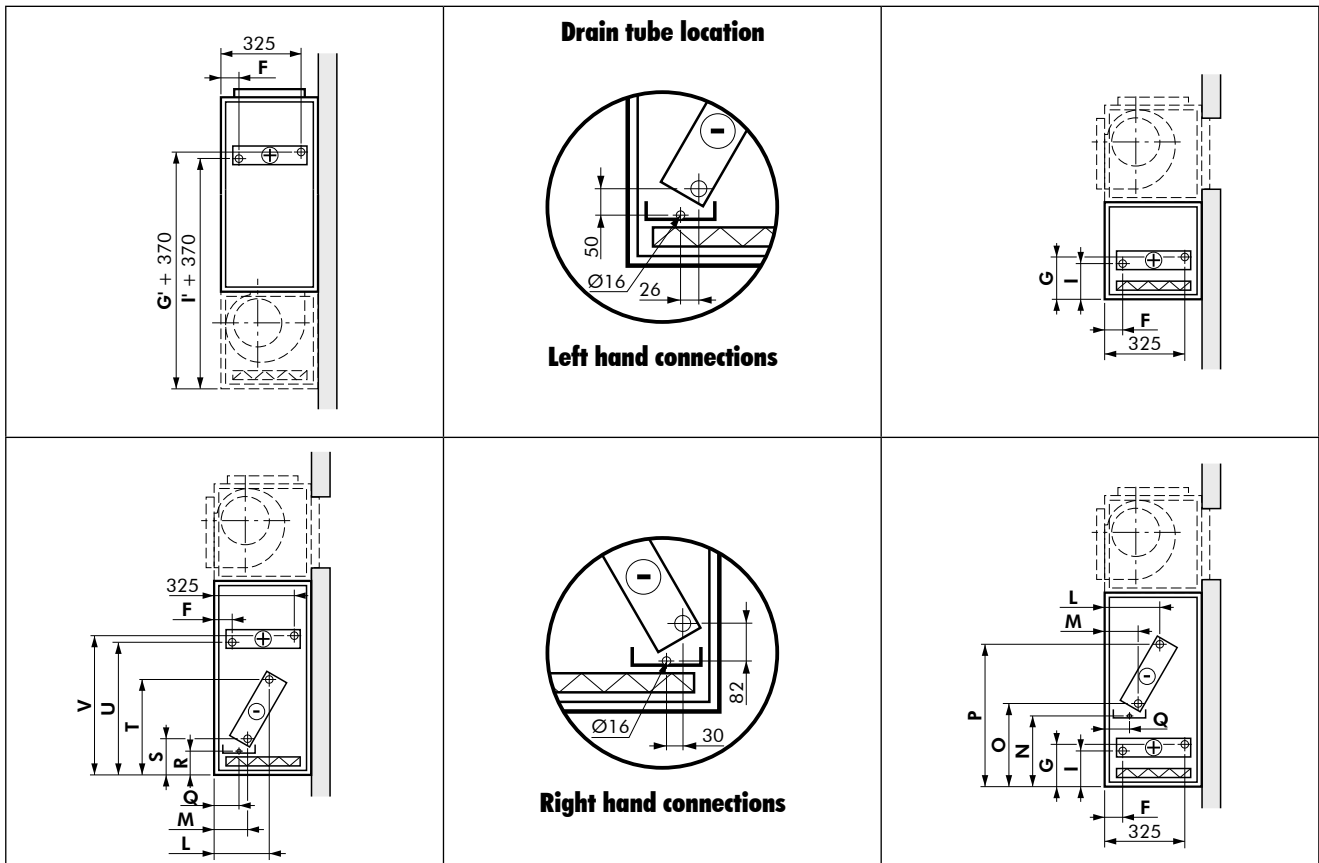

All units are shown with **left hand** connections.

Hand services	A	A'	B	B'	C	C'	D	D'	E	F	G	G'	H	H'	I
Left	133	503	336	706	67	437	298	668	55	45	105	475	228	598	67
Right	67	437	298	668	133	503	336	706	35	45	67	437	162	532	105

Hand services	I'	J	J'	K	L	M	N	O	P	Q	R	S	T	U	V
Left	437	162	532	73	195	111	249	299	574	85	52	102	377	552	590
Right	475	228	598	7	252	55	249	331	541	85	52	134	344	590	552

- Connection type of heating and cooling coils : Ø 26/34 mm Male threaded (header extension is 37 mm).
- Connection type of cooling coil drain pan : copper tube Ø16 mm (tube extension is 20 mm).
- For an optimal efficiency, coils are to be connected per counter flow configuration.

Dimensions of Basic Sections (in mm)

Modules : 0, 1, 2, 3, 4, 5, 6, 7, 8, 9, HM8, HM9, VM8, VM9, Diffusion section

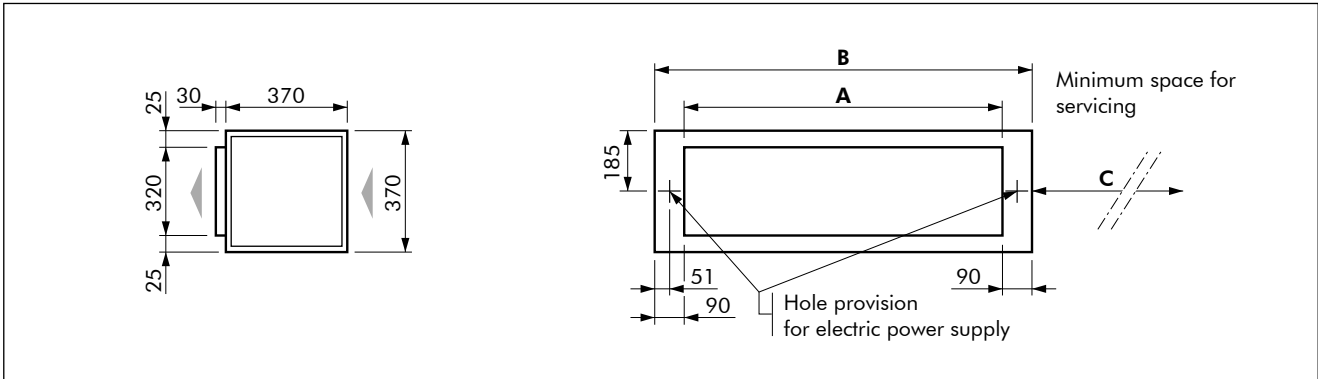

Modules : HP0, HP1, HP2, HP3, HP4, HP5, HP6, HP7, HM80, HM81, HM82, HM83, HM90, HM91, HM92, HM93, PAS

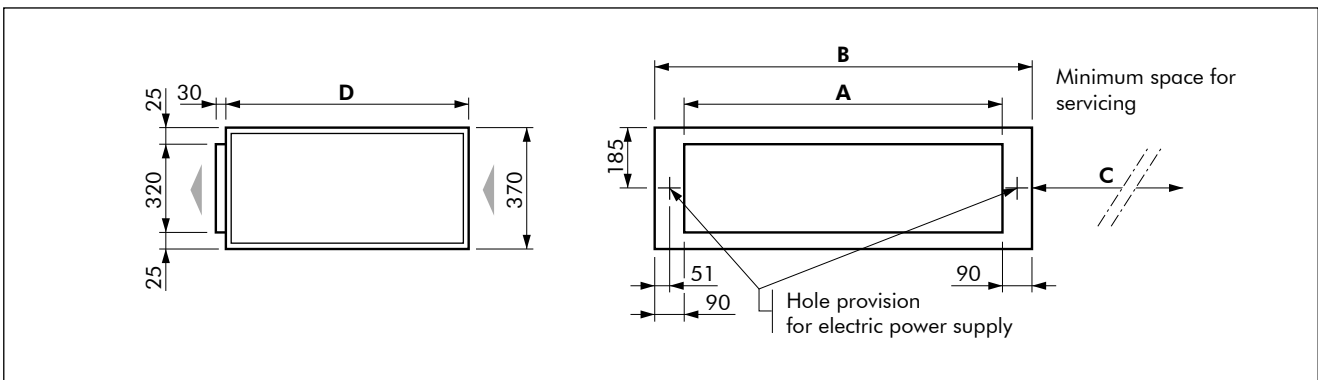

Modules : HM49, HM59, HM69, HM79

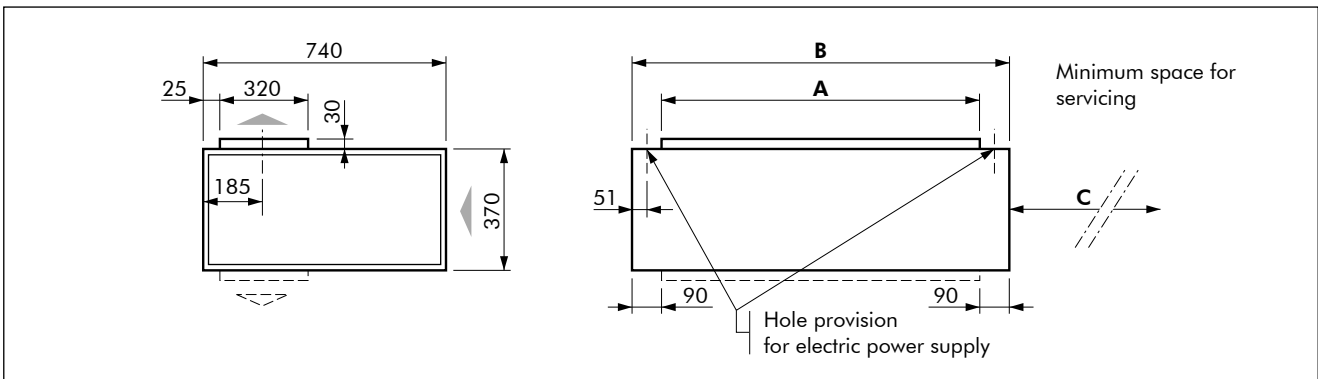

Sizes	1.39	2.69	3.99
A	582	970	1320
B	762	1150	1500
C	779	1167	1517
D	740 (for arrangements HP0, HP1, HP2, HP3, HP4, HP5, HP6, HP7 and PAS) 1110 (for arrangements HM80, HM81, HM82, HM83, HM90, HM91, HM92 and HM93)		

Dimensions in mm.

Dimensions of Basic Sections (in mm)

Modules : VP1, VP6, VP7, VM80, VM90

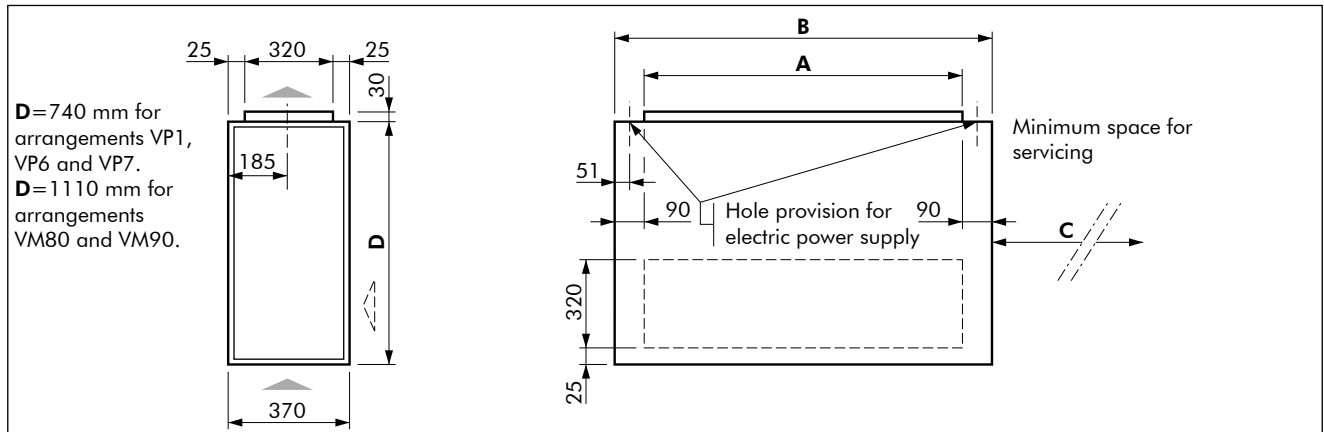

Modules : VM19, VM69, VM79

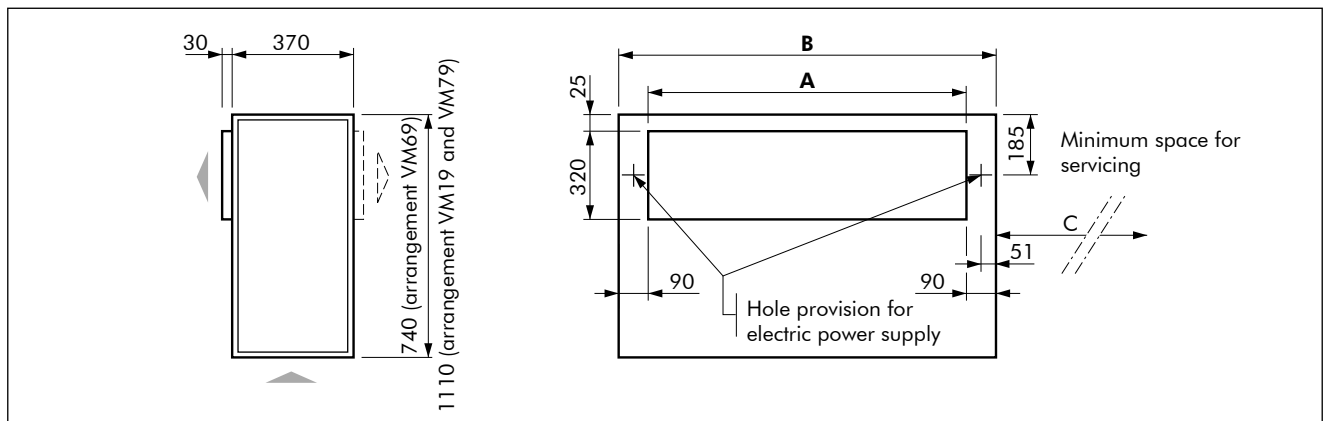

Modules : VM39, VM49, VM59

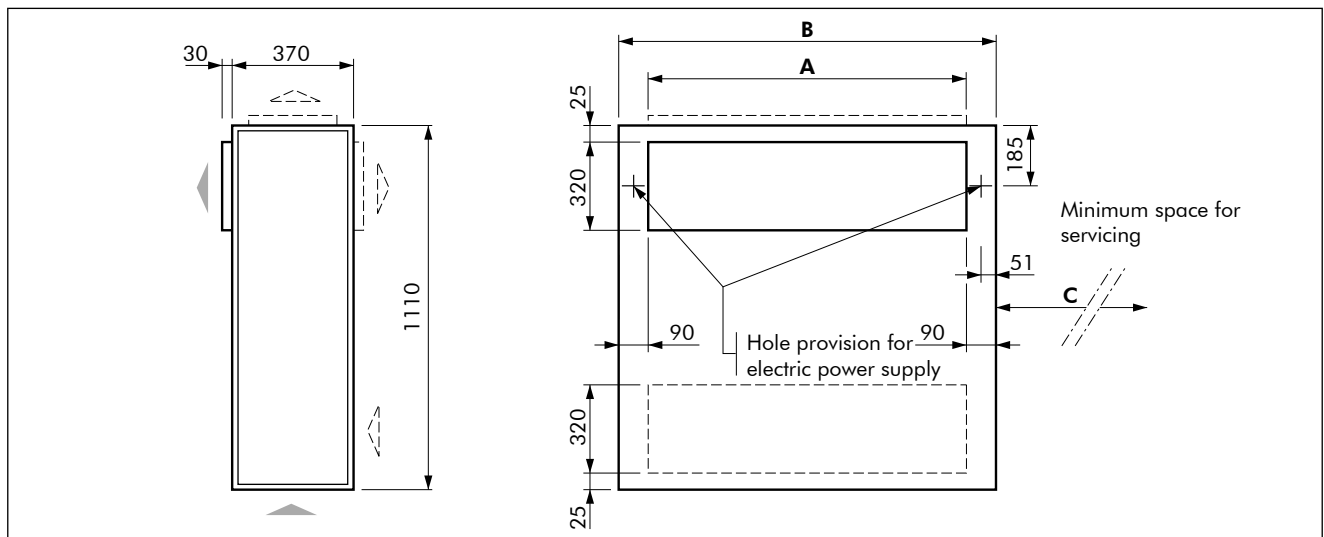

Sizes	1.39	2.69	3.99
A	582	970	1320
B	762	1150	1500
C	779	1167	1517

Dimensions in mm.

Dimensions of Options and Accessory

2-way mixing box "MD1"

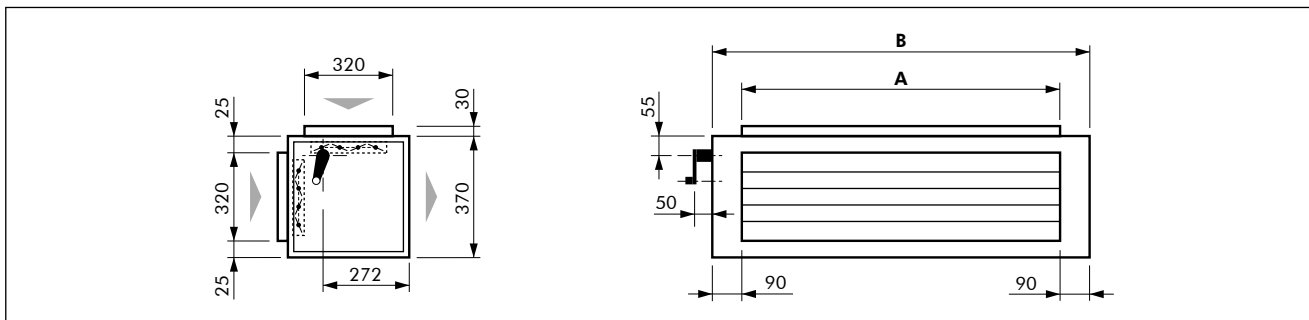

2-way mixing box "MD2"

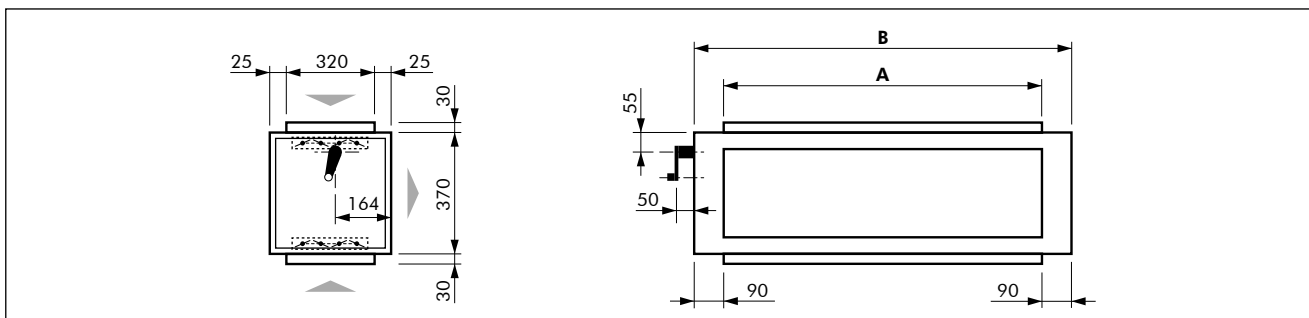

In-line 3-way mixing box "MD3"

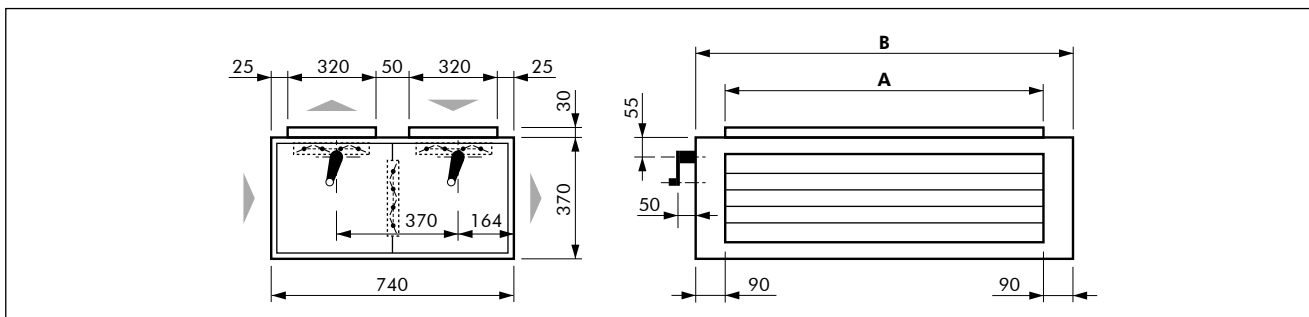

Sizes	1.39	2.69	3.99
A	582	970	1320
B	762	1150	1500

✓ Mixing boxes are supplied with ball joint assembly suitable for Ø 6 mm linking rod.

Dimensions in mm.

Dimensions of Options and Accessory (continued)

Superposed 3-way mixing box "MD3"

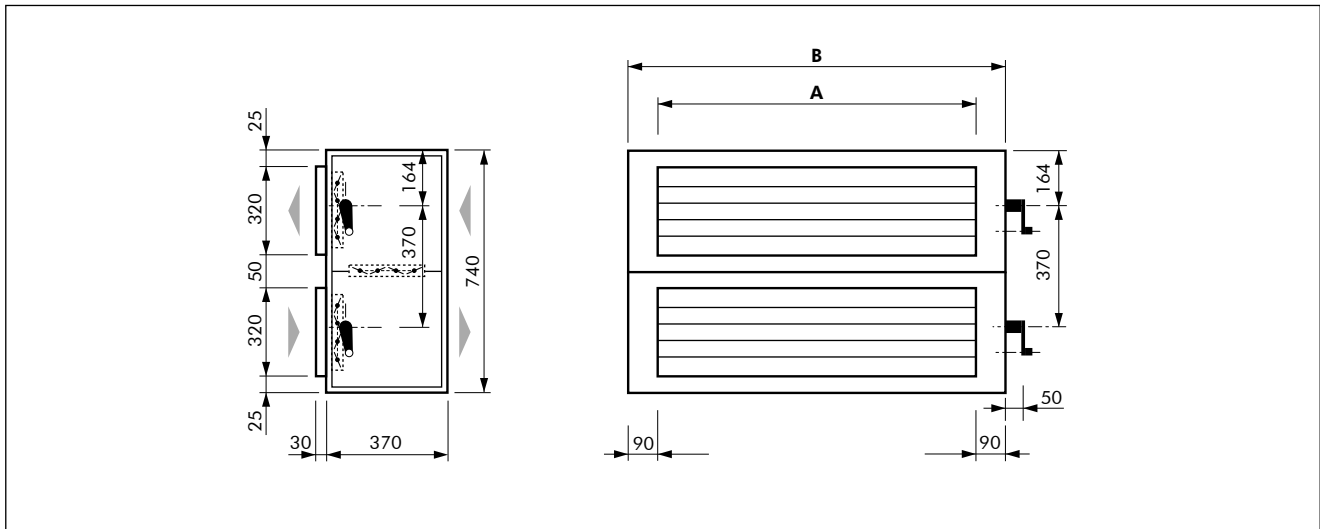

Antifreeze damper "AG"

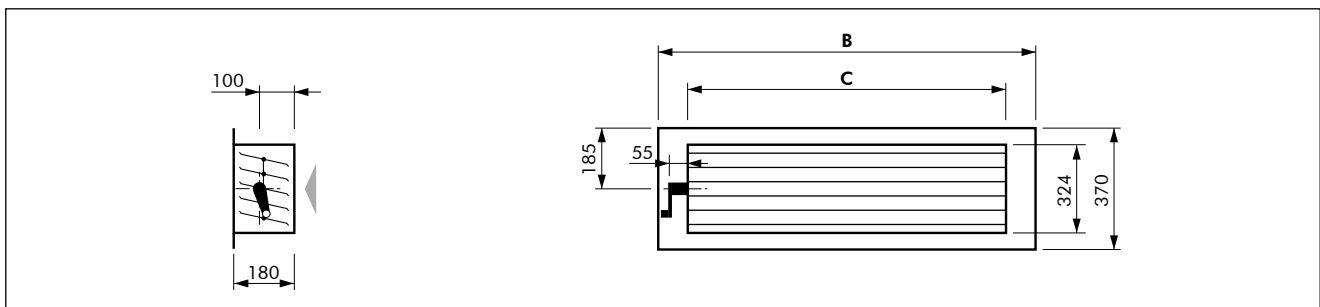

Sizes	1.39	2.69	3.99
A	582	970	1320
B	762	1150	1500
C	586	974	1324

- ✓ Antifreeze damper and mixing box are supplied with ball joint assembly suitable for \varnothing 6 mm linking rod.

Dimensions in mm.

Dimensions of Options (in mm)

External filter : FA1 - FA2 - FA4

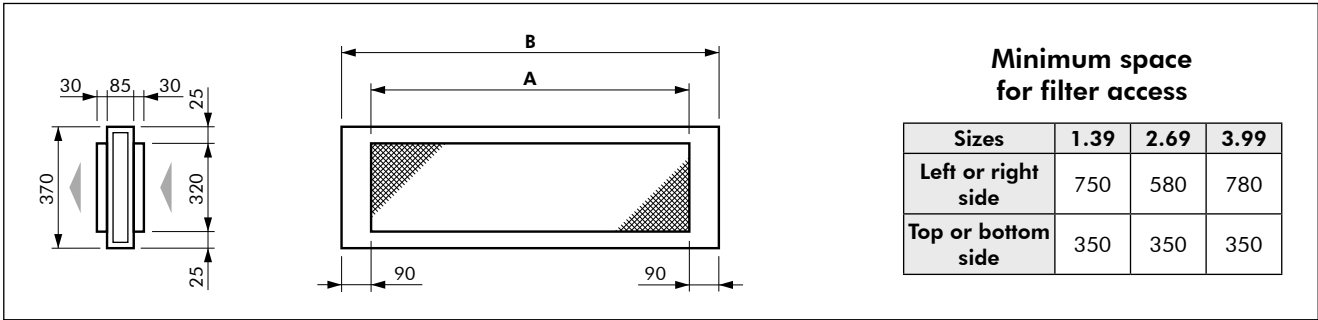
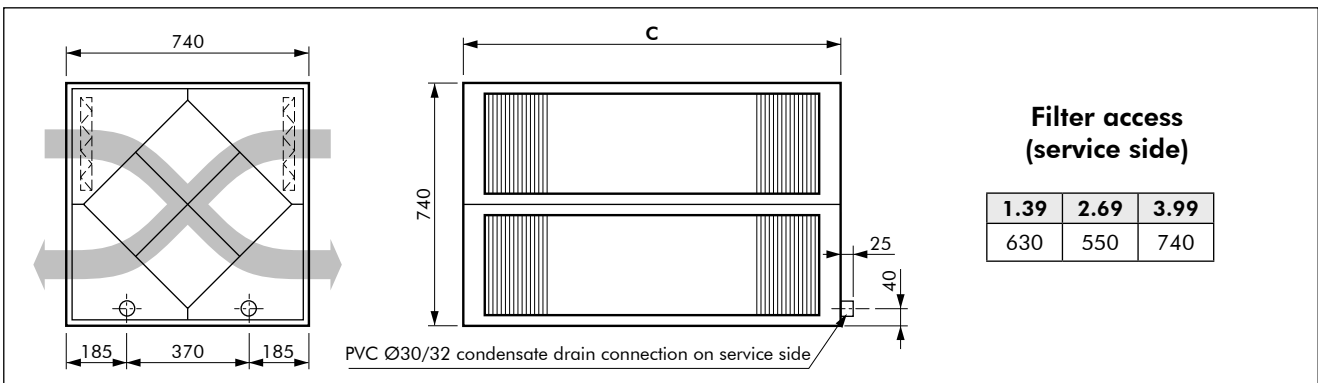
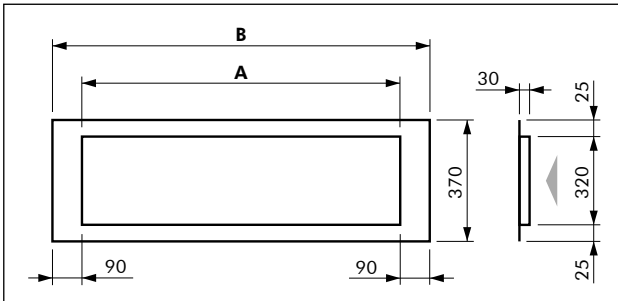

Plate heat exchanger for heat recovery : RP



Inlet duct collar : CA



Flexible connectors : M

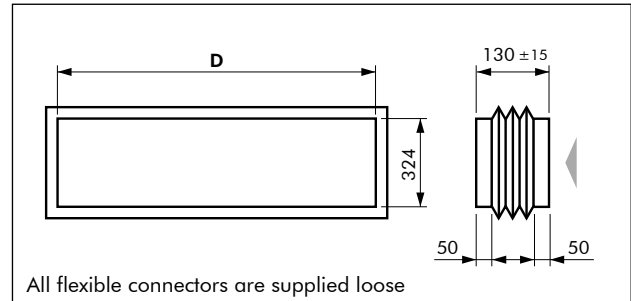

Discharge plenum : PLE

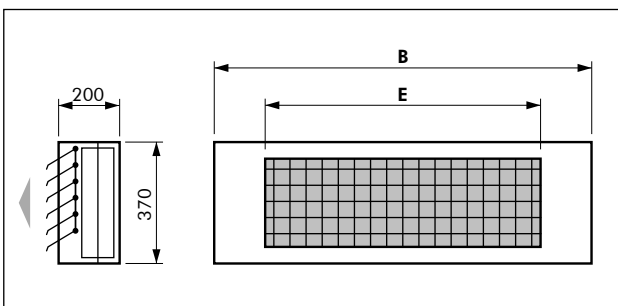

Discharge plenum : R

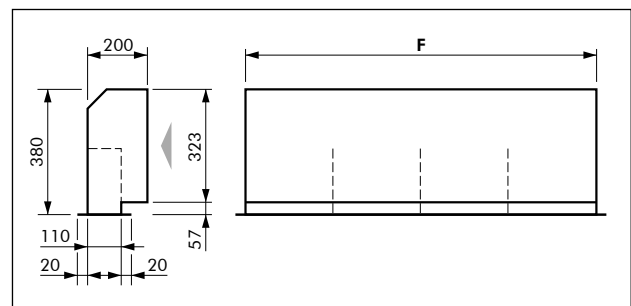

Sizes	A	B	C	D	E	F
1.39	582	762	710	586	390	587
2.69	970	1150	1098	974	790	975
3.99	1320	1500	1448	1324	1190	1325

Dimensions in mm.

Inlet and Bracket Arrangements

Rear inlet

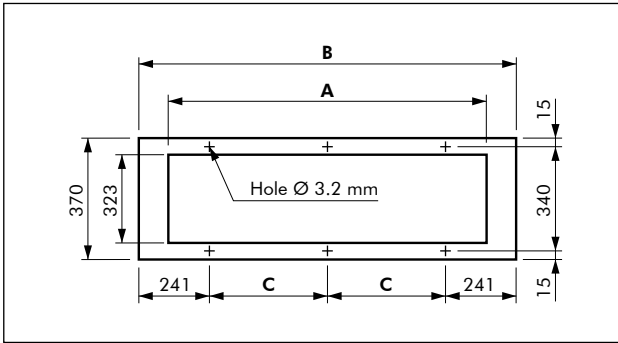

Side inlet

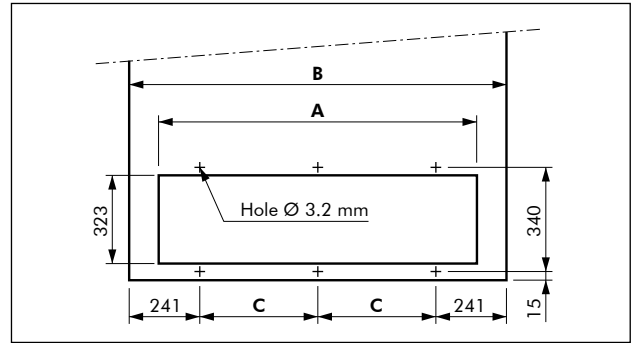

Sizes	1.39	2.69	3.99
A	585	973	1323
B	762	1150	1500
C	140	334	509

BRACKETS ARRANGEMENTS		CEILING MOUNTING													
<p>Technical drawing of bracket arrangements. It shows two views of a bracket. The top view shows a total length of 1540 mm, with a section of 800 mm and another of 740 mm. The height is 20 mm. The side view shows a width of 51 mm and dimensions A and B.</p>		<p>Diagram of ceiling mounting. It shows a unit being mounted to a ceiling with a 20 mm gap between the unit and the ceiling.</p>													
<table border="1"> <thead> <tr> <th>Sizes</th> <th>1.39</th> <th>2.69</th> <th>3.99</th> </tr> </thead> <tbody> <tr> <td>A</td> <td>992</td> <td>1310</td> <td>1660</td> </tr> <tr> <td>B</td> <td>660</td> <td>1048</td> <td>1398</td> </tr> </tbody> </table>		Sizes	1.39	2.69	3.99	A	992	1310	1660	B	660	1048	1398	<p>Diagram of floor mounting. It shows a unit being mounted to a floor.</p>	
Sizes	1.39	2.69	3.99												
A	992	1310	1660												
B	660	1048	1398												
ASSEMBLING SUPPORTS FOR DOUBLE SECTION UNITS		WALL MOUNTING													
<p>Diagram of assembling supports for double section units. It shows a unit being supported by a bracket. The text "Supplied by manufacturer" is next to the bracket.</p>		<p>Diagram of wall mounting. It shows a unit being mounted to a wall.</p>													

Sealing brackets are not supplied by manufacturer.

Weights of Components and Units (in kg)

SIZES	1.39		2.69		3.99	
	SP	DP	SP	DP	SP	DP
SECTIONS						
0 - 6	14	19	21	28	29	37
1 - 7	18	23	27	34	37	45
2 - 3 - 4 - 5	23	28	34	41	46	54
8 - 9	24	29	32	39	41	49
Diffusion section	9	14	14	21	20	28
HORIZONTAL UNITS						
HP2 - HP3 - HP4 - HP5 - HM49 - HM59	46	57	66	80	85	102
HP0 - HP6 - HM69	37	48	53	67	68	85
HP1 - HP7 - HM79 - PAS	41	52	59	73	76	93
HM8 - HM9	24	29	32	39	41	49
HM80 - HM90	46	62	67	88	88	113
HM81 - HM91	50	66	73	94	96	121
HM82 - HM83 - HM92 - HM93	55	71	80	101	105	130
VERTICAL UNITS						
VP1 - VP7	41	52	59	73	76	93
VP6 - VM69	37	48	53	67	68	85
VM19 - VM79	50	66	73	94	96	121
VM39 - VM49 - VM59	55	71	80	101	105	130
VM80 - VM90	46	62	67	88	88	113

SP : single skin.

DP : double skin.

Weight are given for empty coils.

Extra weight for electric heating coils (replacing hot water coil)

Sizes	1.39	2.69	3.99
BE1 (1)	3	5	10
BE2 (1)	6	11	17
BE3 (1)	10	17	21
BF6	6	9	12

(1) Pour remplacement de la batterie eau chaude par une batterie électrique.

Weight of accessories

Sizes	MD1/2	MD3	AG	FA1/2/4	RP	PLE	R	AP	TO
1.39	9	17	5	3	32	7	5	2	1
2.69	14	28	7	5	55	10	8	3	1
3.99	20	38	9	7	94	12	10	4	1

Sizes	EL	Écran RS	Cadre CA	Cadre CR	Manchette M
1.39	1	1	1	1	1
2.69	1	1	1	1	1
3.99	1	1	2	2	1

Weight in kg.

Notes

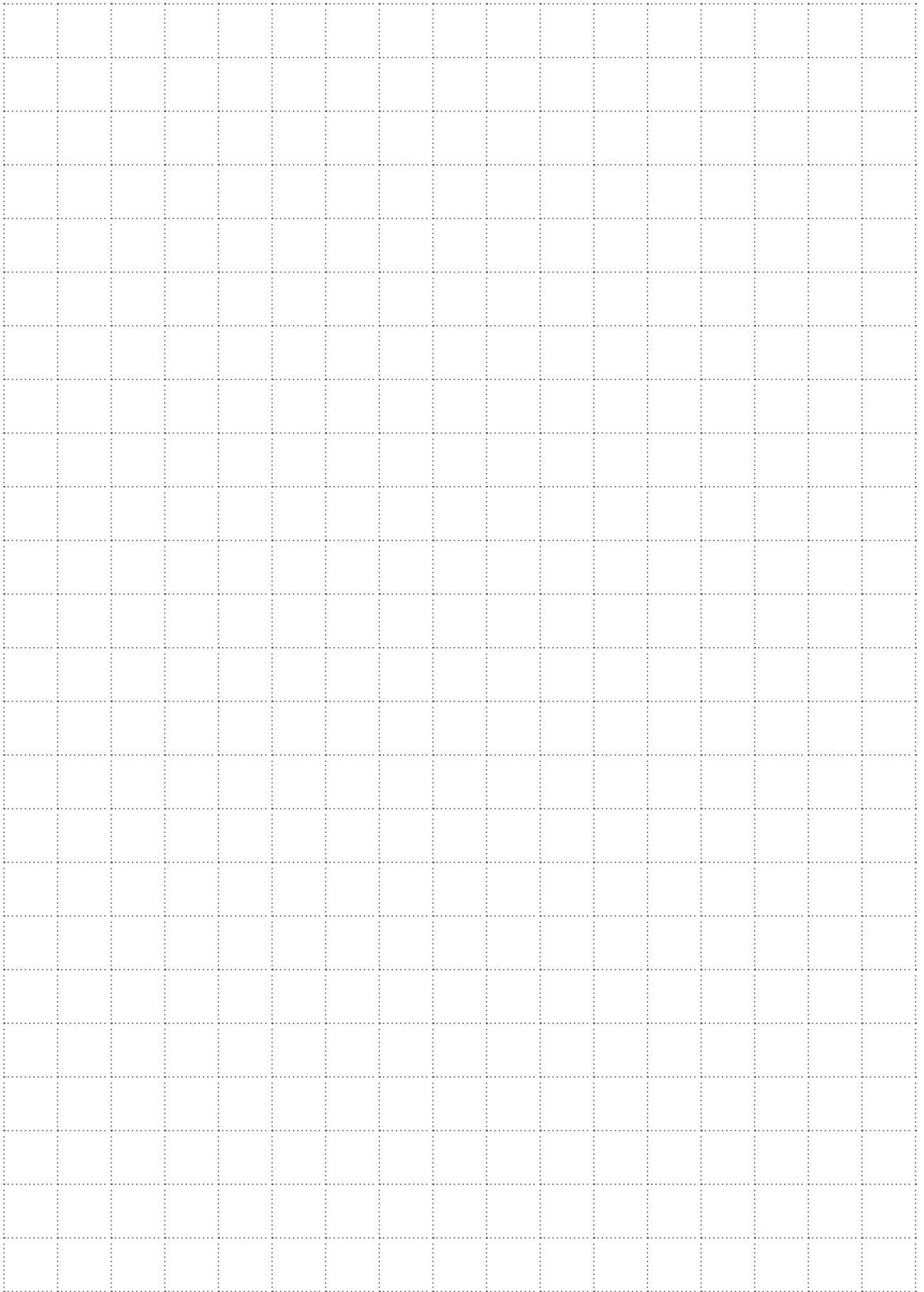



WinPak Selection Software

To select the most suitable Wespak direct drive compact air handling units according to job specifications, Airwell provides a computer selection program operating under MS Windows System.

This selection software allows you to select quickly the best solution for each application.

For any specific requirements, please contact your nearest Airwell distributor.

Airwell

As part of our ongoing product improvement programme, our products are subject to change without prior notice. Non contractual photos.



CAC Export Department
42 cours Jean-Jaurès
17800 Pons - France
Tel. : +33 (0)5 46 92 33 33 - Fax : +33 (0)5 46 91 26 44

Your distributor :