

► Air Cooled Condensing Units

VLC 524 to 1204



154 to 347 kW



Engineering Data Manual

EDM VLC410-A.1GB

Date : May 2007

Supersedes : None

Airwell

Key Points

- Units with **R410A refrigerant** (it will be the real replacement of R22). As near azeotropic mixture it behaves like a homogeneous substance (**reduced service problems in case of leakage or re-charge**) with negligible temperature glide.

Refrigerant with superior thermo-dynamical proprieties compared to R22 and R407C, it allows to have more efficiency or compact and lighter systems and larger operating limits (T ambient = -10 °C in heating mode).

- With except for the fans, all the versions keep the same configuration of the base units (same structure, electrical board, compressors and coils). **Easy upgrade of the units in stock or on the field.**
- Optimized coils design (30% refrigerant charge reduction).
- **Compressors box (less sound proofing) always installed** - additional compressors jackets only for ELN version (**easy upgrade of the units in stock**).
- Special version (HSE) developed for high seasonal efficiency (ESEER higher than 4.5 (more than 15% compared to standard

version)) and high operation limits with inverter fans (electronic brushless type motor). Axial fan of large diameter.

- Special version (SIF) for high external static pressure (max. 120 Pa) with inverter fans (electronic brushless type motor). Axial fan of large diameter. These fans are the same as those used on HSE units.
- Modified and improved base frame - AVM fitted underneath of base frame so no brackets request (no problem for track and container freight). In the same positions, the plastic feet will be installed for fork handling.
- **New microprocessor** : 4 times greater RAM memory compared with previous version, flash memory card and compressors envelope curves put inside, 3 times faster than previous control.
- For service operation, special valves dedicated to R410A are supplied on the refrigerant system. These valves, of 5/16" flare SAE type, are mounted on the liquid line and on the gauges manifold of the unit.

Technical Features

General

The new **VLC** units have been designed to operate with **HFC 410A** refrigerant. Both compressors and heat exchangers have been optimized for this refrigerant.

They consist of **two independent refrigerant circuits**, a tandem high efficiency and low vibration level Scroll compressors on each circuit and a ventilating unit comprising V-shape coils and quiet fans; each of them is located in an externally mounted nozzle profile housing generating low sound level.

The VLC units are available in **8 sizes**, from size 524 to 1204, with a nominal capacity range from **154 to 347 kW**.

The **VLC-STD (Standard) version** can be supplied with **3 acoustic options** :

- **Base Low Noise (BLN)** : The units are equipped with **delta connected fans** implying a standard rpm. The units are not supplied with fan speed controller, but fitted with **compressors box** to reduce the noise emissions.
- **Low Noise (LN)** : The units are equipped with **star connected fans** implying a low rpm. The units are not supplied with fan speed controller, but fitted with **compressors box** to reduce the noise emissions.
- **Extra Low Noise (ELN)** : The units are equipped with **star connected fans**, fitted with a speed controller which allows the units to operate with a very low rpm. The units are supplied with **compressors box** and **soundproof jackets** on compressors reducing significantly the noise emissions.

To increase their field of applications, the VLC ranges are available in **3 additional versions** :

- **HSE (High Seasonal Efficiency) version** : It has same equipment as that of the STD version, except that the units are equipped with **special inverter fans**, of large diameter, driven by **EC (electronic brushless type) motors** with **integrated electronic inverter**, to ensure low energy consumption. This version can be supplied with BLN, LN or ELN acoustic options.
- **HT (High Temperature) version** : It has same equipment as that of the BLN units, but the units are fitted with **special inverter fans and motors** identical to those of the HSE version, but with a different regulation. The HT version can be supplied with BLN acoustic option only.
- **SIF (Special Inverter Fan) version** : It has same equipment as that of the BLN units, except that the units are equipped with **special inverter fans** (same as those used on HSE version, but with a different regulation) driven by **EC motors** with **integrated electronic inverter**. The SIF version provides external static pressure up to **120 Pa**. This version can be supplied with BLN acoustic option only.

Reference standards

The following applies to all the sizes and versions of VLC units :

- ✓ Machine Directive EEC 98/37 (EN 292/1, EN 292/2)
- ✓ Low Voltage Directive EEC 73/23 (EN 60204-1, EN 60439-1)
- ✓ Electromagnetic Compatibility Directive EEC 89/336 as modified by Directive EEC 92/31 (EN 50081-1, EN 50082-2)
- ✓ Pressure Equipment Directive 97/23/CE

Cabinet and structure

The unit cabinet and structure are made of heavy gauge galvanized steel coated with polyester powder based painting (RAL 9001). All parts of the structure are fastened totally with non-corrosive screws and bolts.

Compressors

Each unit is equipped with four compressors arranged in two tandems to suit the two refrigerant circuits.

The compressors are of hermetic scroll type and fitted with an electronic control system ensuring protection against high temperature and excessive load.

All compressors have direct-on-line starting and are mounted on rubber vibration isolators in order to minimize noise and vibration transmission.

Condenser coils

The condenser coils are made of seamless copper tubes, arranged in staggered rows, mechanically expanded into corrugated aluminum fins.

Condenser fans

For each size, all versions keep the same number of fans.

Large diameter, direct drive axial type fans with asynchronous three-phase motors are used in all acoustic versions (BLN, LN & ELN) of VLC 524-1204 STD units.

Special inverter fans with electronic brushless type motors are used in VLC 524-1204 HSE, SIF and HT units.

On high pressure fans of SIF units, the external static pressure (≤ 120 Pa) can be adjusted on site to match the customer demand directly from the electronic control panel of the unit.

Fans are equipped with externally mounted nozzle profile housing which generates low sound levels.

Technical Features (continued)

Fan speed control

The speed of fans is controlled in order to operate at a low ambient temperature.

On units with standard axial fans, the fan speed control, supplied as standard, is of a temperature actuated step type (for BLN and LN versions) and of a pressure actuated stepless type with an electronic controller (for ELN version).

The pressure actuated stepless type fan speed controller can be supplied as optional on BLN and LN versions. It allows the units to operate in cooling mode at ambient temperature down to -18 °C.

On HSE and SIF units with electronic axial fans, the pressure actuated stepless type fan speed control is supplied as standard, because these electronic fans are already equipped with an integrated fan speed control (fan speed range : 50 to 1200 rpm; ambient temperature limit : -18 °C).

Refrigerant circuits

All the units are composed of two independent and separate refrigerant circuits.

Each refrigerant circuit is equipped with suction and liquid line shut-off valves to allow the connection of the unit to the external evaporator.

The functional diagram of each circuit is shown in the section "Refrigerant flow diagram".

Electrical board

Metal case, externally arranged at one end of the unit. Case for the board with IP54 protection rating, complete with grille for natural air ventilation of the box.

Control and safety devices

Each unit is fitted with the following devices :

Safety :

- Power disconnect switch with an emergency stop function.
- HP switches (double on each circuit of sizes 1004 to 1204), set to 42 bar, automatic reset and manual reset from the control panel.
- Safety valve on discharge lines, set to 46 bar.

Control :

- HP and LP transducers (two for each circuit).
- Ambient air temperature sensor.

Electronic control

The units are supplied with the new microprocessor-based electronic control and management system ensuring the following functions :

- Management of the operation of compressors :
 - a) Power on/off
 - b) Anticycle management
 - c) Tandem unloading for high pressure or high compressor pressure ratio (integrated inside the curves of compressor operating limits).
- Management of high and low pressure alarms.
- Management of external interlocks.
- Management of the remote control :
 - d) Unit power on/off
 - e) Summary alarm signals
- Remote signalling, by dry contacts :
 - f) Voltage presence
 - g) Compressors in operation
 - h) Alarm, circuit 1
 - i) Alarm, circuit 2

The unit controller can also clearly show all control parameters of the machine on the liquid crystal display, such as :

- Display of the ambient air temperature.
- Display of the circuit 1 and circuit 2 discharge pressure and suction pressure.
- Display of the set point.
- Display of the various alarm and operation status :
 - j) Compressor start-up alarm (discharge pressure check)
 - k) Low / High pressure
 - l) Control of the compressor operating hours
 - m) Compressors in operation
 - n) Thermal protection of compressors
 - o) Thermal protection of fans
 - p) Faulty sensors

Standard equipment

- ✓ Set point timer/clock card.
- ✓ Temperature actuated fan speed control.
- ✓ Back light display.
- ✓ Digital pressure and temperature reading kit.
- ✓ High ambient pressure control.
- ✓ Sequence phase control.
- ✓ Control circuit transformer 400 V/230 V.
- ✓ Data logger.
- ✓ Power supply without neutral.
- ✓ Hour meter.
- ✓ Main switch.
- ✓ Refrigerant R410A.
- ✓ PED approval.
- ✓ Compressor jacket (ELN version only).
- ✓ Compressor box.
- ✓ Rubber anti-vibration pad.

Factory installed options

- ✓ ModBus protocol kit for BMS.
- ✓ Lonwork protocol kit for BMS.
- ✓ Bacnet protocol kit for BMS.
- ✓ Compressors soft starter.
- ✓ Pressure actuated stepless fan speed controller for low ambient operation (-18 °C).
- ✓ Power factor correction capacitors.
- ✓ Compressors overload protection.
- ✓ GSM.
- ✓ HP & LP manometers.
- ✓ Condenser coils with blue fins treatment.
- ✓ Condenser coils with "Fin Guard Silver" (polyurethane) treatment.
- ✓ Condenser coils with copper fins.
- ✓ Chiller grilles.

Field-installed accessories

- ✓ Remote ON/OFF control.
- ✓ Airconet protocol kit for BMS.
- ✓ Remote keyboard panel.
- ✓ Master and slaves control, up to 4 units max.
- ✓ Spring anti-vibration mounts for basic unit.
- ✓ Spring anti-vibration mounts for unit with copper fins.

Refrigerant Flow Diagram

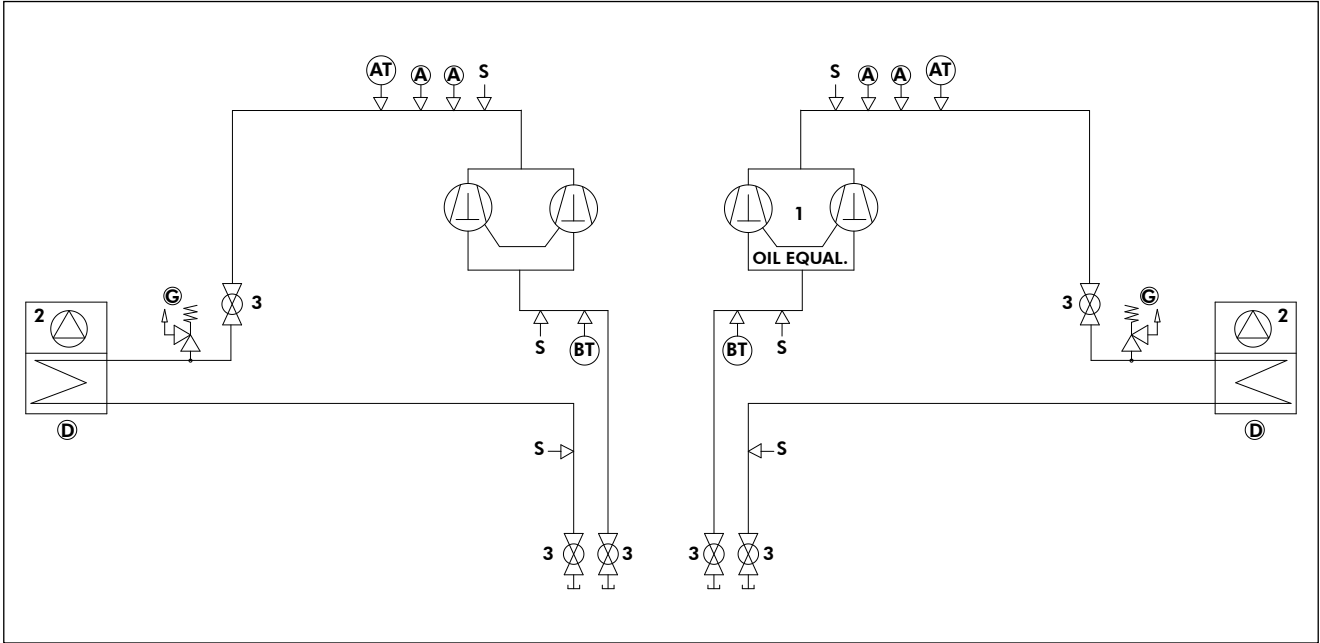

COMPONENTS	
1	Tandem Scroll type compressor
2	Air cooled condenser
3	Globe valve

SAFETY / CONTROL DEVICES	
	High pressure switch
	High pressure transducer
	Low pressure transducer
	Air temperature sensor
	PED pressure relief valve
	5/16" valve connection (service only)
	Pipe connection with Shrader valve

Operating Limits and Correction Factors

Operating limits - VLC 524 to 804

VLC			524		604		704		804	
			Min.	Max.	Min.	Max.	Min.	Max.	Min.	Max.
Evaporating temperature			°C		+3 to +15					
Ambient air	Air entering temperature	Cooling - BLN	°C		+0 to +46 (1)	-5 to +47 (1)	-5 to +47 (1)	+0 to +46 (1)		
		Cooling - LN/ELN	°C		+0 to +44 (1)	-5 to +45 (1)	-5 to +45 (1)	+0 to +44 (1)		
		Cooling - HT	°C		-18 to +48 (1)	-18 to +49 (1)	-18 to +49 (1)	-18 to +48 (1)		
	External static pressure	Standard fans	Pa		0					
		Special inverter fans	Pa		≤120					
Power supply voltage (2)			400 V / 3 Ph / 50 Hz (nominal)							

(1) High pressure switch at 42 bar.

(2) Voltage : 400 V ± 10 %

Operating limits - VLC 904 to 1204

VLC			904		1004		1104		1204	
			Min.	Max.	Min.	Max.	Min.	Max.	Min.	Max.
Evaporating temperature			°C		+3 to +15					
Ambient air	Air entering temperature	Cooling - BLN	°C		+0 to +47 (1)	+0 to +46 (1)	+0 to +45 (1)	+0 to +45 (1)		
		Cooling - LN/ELN	°C		+0 to +45 (1)	+0 to +44 (1)	+0 to +42 (1)	+0 to +42 (1)		
		Cooling - HT	°C		-18 to +49 (1)	-18 to +48 (1)	-18 to +47 (1)	-18 to +47 (1)		
	External static pressure	Standard fans	Pa		0					
		Special inverter fans	Pa		≤120					
Power supply voltage (2)			400 V / 3 Ph / 50 Hz (nominal)							

(1) High pressure switch at 42 bar.

(2) Voltage : 400 V ± 10 %

Fouling factors

CONDENSER		
Fouling factor (m ² .°C/kW)	Cooling capacity factor	Power input factor
0.044	1.000	1.000
0.088	0.987	1.023
0.176	0.955	1.068
0.352	0.910	1.135

Altitude factors

Altitude (m)	Cooling capacity factor	Power input factor
0	1.000	1.000
600	0.987	1.010
1200	0.973	1.020
1800	0.958	1.029
2400	0.943	1.038

Physical Data - VLC STD/HSE/SIF - BLN Version

VLC STD/HSE/SIF-BLN models		524	604	704	804	904	1004	1104	1204
Nominal cooling capacity (1)	kW	154.0	174.0	199.0	224.0	258.0	283.0	315.0	347.0
Input power (2)	kW	47.5	52.5	63.0	69.0	79.0	83.0	98.0	112.0
Number of refrigerant circuits		2	2	2	2	2	2	2	2
Total capacity steps	%	25-50 75-100	28-57 78-100	20-50 70-100	25-50 75-100	28-50 78-100	25-50 75-100	23-50 73-100	25-50 75-100
COMPRESSORS									
Number		4	4	4	4	4	4	4	4
Type		SCROLL							
Oil type		POE							
N° of loading stages		0/100	0/100	0/100	0/100	0/100	0/100	0/100	0/100
AIR COOLED CONDENSERS									
Number of coils		2	2	2	2	2	2	2	2
Total coil face area per coil	m ²	3.5	3.5	4.8	4.8	4.8	4.8	4.8	4.8
FANS									
Number of fans		2	3	3	3	4	4	4	4
Nominal speed	rpm	900	900	900	900	900	900	900	900
Total airflow	m ³ /h	46300	63000	68300	68300	85000	80000	75500	75500
Total input power	kW	3.8	5.7	5.7	5.7	7.6	7.6	7.6	7.6
Total input power (*)	kW	2.6	4.0	4.0	4.0	5.3	5.3	5.3	5.3
External static pressure	Pa	0 or 120 Pa (**)							
REFRIGERANT CONNECTION									
In	inch	7/8"	7/8"	7/8"	7/8"	1 1/8"	1 1/8"	1 1/8"	1 1/8"
Out	inch	1 5/8"	1 5/8"	1 5/8"	1 5/8"	2 1/8"	2 1/8"	2 1/8"	2 1/8"
WEIGHT									
Shipping weight	kg	1080	1300	1490	1615	1700	1825	1910	1920
ADDITIONAL WEIGHT									
HSE version	kg	30	30	30	30	40	40	40	40
SIF version	kg	10	10	10	10	15	15	15	15
SOUND LEVELS									
Sound power level (3)	dB(A)	92	93	93	93	94	94	95	95
Sound pressure level - (10 m) (4)	dB(A)	60	61	61	61	62	62	63	63
DIMENSIONS									
Length	mm	3300	3300	4300	4300	4300	4300	4300	4300
Width	mm	1100	1100	1100	1100	1100	1100	1100	1100
Height	mm	2300	2300	2300	2300	2300	2300	2300	2300

(1) Data based on 7 °C evaporating temperature and 35 °C ambient air temperature.

(2) Compressors only.

(3) Sound levels are at fully loaded conditions. Sound power level values refer to ISO standard 3744 and Eurovent 8/1.

(4) Sound pressure levels refer to ISO standard 3744, parallelepiped shape.

(*) High efficiency units (HSE) with inverter fans.

(**) SIF units with high static pressure fans.

Physical Data - VLC STD/HSE - LN Version

VLC STD/HSE-LN models		524	604	704	804	904	1004	1104	1204
Nominal cooling capacity (1)	kW	149.0	169.0	194.0	218.0	251.0	272.5	301.0	330.0
Input power (2)	kW	50.0	55.0	66.0	73.0	83.0	88.0	104.0	121.0
Number of refrigerant circuits		2	2	2	2	2	2	2	2
Total capacity steps	%	25-50 75-100	28-57 78-100	20-50 70-100	25-50 75-100	28-50 78-100	25-50 75-100	23-50 73-100	25-50 75-100
COMPRESSORS									
Number		4	4	4	4	4	4	4	4
Type		SCROLL							
Oil type		POE							
N° of loading stages		0/100	0/100	0/100	0/100	0/100	0/100	0/100	0/100
AIR COOLED CONDENSERS									
Number of coils		2	2	2	2	2	2	2	2
Total coil face area per coil	m ²	3.5	3.5	4.8	4.8	4.8	4.8	4.8	4.8
FANS									
Number of fans		2	3	3	3	4	4	4	4
Nominal speed	rpm	700	700	700	700	700	700	700	700
Total airflow	m ³ /h	35400	47300	52200	52200	63700	58800	54900	54900
Total input power	kW	2.4	3.6	3.6	3.6	4.8	4.8	4.8	4.8
Total input power (*)	kW	1.2	1.9	1.9	1.9	2.5	2.5	2.5	2.5
External static pressure	Pa	0							
REFRIGERANT CONNECTION									
In	inch	7/8"	7/8"	7/8"	7/8"	1 1/8"	1 1/8"	1 1/8"	1 1/8"
Out	inch	1 5/8"	1 5/8"	1 5/8"	1 5/8"	2 1/8"	2 1/8"	2 1/8"	2 1/8"
WEIGHT									
Shipping weight	kg	1080	1300	1490	1615	1700	1825	1910	1920
ADDITIONAL WEIGHT									
HSE version	kg	30	30	30	30	40	40	40	40
SOUND LEVELS									
Sound power level (3)	dB(A)	86	87	87	87	88	88	89	89
Sound pressure level - (10m) (4)	dB(A)	54	55	55	55	56	56	57	57
DIMENSIONS									
Length	mm	3300	3300	4300	4300	4300	4300	4300	4300
Width	mm	1100	1100	1100	1100	1100	1100	1100	1100
Height	mm	2300	2300	2300	2300	2300	2300	2300	2300

(1) Data based on 7 °C leaving chilled water temperature and 35 °C ambient air temperature.

(2) Compressors only.

(3) Sound levels are at fully loaded conditions. Sound power level values refer to ISO standard 3744 and Eurovent 8/1.

(4) Sound pressure levels refer to ISO standard 3744, parallelepiped shape.

(*) High efficiency units (HSE) with inverter fans.

Physical Data - VLC STD/HSE - ELN Version

VLC STD/HSE-ELN models		524	604	704	804	904	1004	1104	1204
Nominal cooling capacity (1)	kW	144.0	164.5	188.5	211.0	244.0	264.5	292.0	319.0
Input power (2)	kW	52.5	57.0	69.0	76.5	86.5	91.5	108.0	127.0
Number of refrigerant circuits		2	2	2	2	2	2	2	2
Total capacity steps	%	25-50 75-100	28-57 78-100	20-50 70-100	25-50 75-100	28-50 78-100	25-50 75-100	23-50 73-100	25-50 75-100
COMPRESSORS									
Number		4	4	4	4	4	4	4	4
Type		SCROLL							
Oil type		POE							
N° of loading stages		0/100	0/100	0/100	0/100	0/100	0/100	0/100	0/100
AIR COOLED CONDENSER									
Number of coils		2	2	2	2	2	2	2	2
Total coil face area per coil	m ²	3.5	3.5	4.8	4.8	4.8	4.8	4.8	4.8
FANS									
Number of fans		2	3	3	3	4	4	4	4
Nominal speed	rpm	550	550	550	550	550	550	550	550
Total airflow	m ³ /h	28300	38500	41800	41800	52000	48900	46200	46200
Total input power	kW	2	3	3	3	4	4	4	4
Total input power (*)	kW	0.6	0.9	0.9	0.9	1.2	1.2	1.2	1.2
External static pressure	Pa	0							
REFRIGERANT CONNECTION									
In	inch	7/8"	7/8"	7/8"	7/8"	1 1/8"	1 1/8"	1 1/8"	1 1/8"
Out	inch	1 5/8"	1 5/8"	1 5/8"	1 5/8"	2 1/8"	2 1/8"	2 1/8"	2 1/8"
WEIGHT									
Shipping weight	kg	1110	1335	1525	1650	1735	1865	1950	1960
ADDITIONAL WEIGHT									
HSE version	kg	30	30	30	30	40	40	40	40
SOUND LEVELS									
Sound power level (3)	dB(A)	83	83	83	83	84	84	85	85
Sound pressure level - (10m) (4)	dB(A)	51	51	51	51	52	52	53	53
DIMENSIONS									
Length	mm	3300	3300	4300	4300	4300	4300	4300	4300
Width	mm	1100	1100	1100	1100	1100	1100	1100	1100
Height	mm	2300	2300	2300	2300	2300	2300	2300	2300

(1) Data based on 7 °C evaporating temperature and 35 °C ambient air temperature.

(2) Compressors only.

(3) Sound levels are at fully loaded conditions. Sound power level values refer to ISO standard 3744 and Eurovent 8/1.

(4) Sound pressure levels refer to ISO standard 3744, parallelepiped shape.

(*) High efficiency units (HSE) with inverter fans.

Physical Data - VLC HT

VLC HT models		524	604	704	804	904	1004	1104	1204
Nominal cooling capacity (1)	kW	155.5	176.0	201.0	226.5	261.0	286.5	318.0	353.0
Input power (2)	kW	47.0	51.5	62.0	68.0	77.5	81.0	95.0	109.0
Number of refrigerant circuits		2	2	2	2	2	2	2	2
Total capacity steps	%	25-50 75-100	28-57 78-100	20-50 70-100	25-50 75-100	28-50 78-100	25-50 75-100	23-50 73-100	25-50 75-100
COMPRESSORS									
Number		4	4	4	4	4	4	4	4
Type		SCROLL							
Oil type		POE							
N° of loading stages		0/100	0/100	0/100	0/100	0/100	0/100	0/100	0/100
AIR COOLED CONDENSERS									
Number of coils		2	2	2	2	2	2	2	2
Total coil face area per coil	m ²	3.5	3.5	4.8	4.8	4.8	4.8	4.8	4.8
FANS									
Number of fans		2	3	3	3	4	4	4	4
Nominal speed	rpm	1110	1110	1110	1110	1110	1110	1110	1110
Total airflow	m ³ /h	51700	71800	76200	76200	95800	91200	87600	87600
Total input power (*)	kW	4.5	7.2	6.9	6.9	9.6	9.9	10	10
External static pressure	Pa	0							
REFRIGERANT CONNECTION									
In	inch	7/8"	7/8"	7/8"	7/8"	1 1/8"	1 1/8"	1 1/8"	1 1/8"
Out	inch	1 5/8"	1 5/8"	1 5/8"	1 5/8"	2 1/8"	2 1/8"	2 1/8"	2 1/8"
WEIGHT									
Shipping weight	kg	1110	1330	1520	1645	1740	1865	1950	1960
SOUND LEVELS									
Sound power level (3)	dB(A)	97	99	99	99	100	100	100	100
Sound pressure level - (10m) (4)	dB(A)	65	67	67	67	68	68	68	68
DIMENSIONS									
Length	mm	3300	3300	4300	4300	4300	4300	4300	4300
Width	mm	1100	1100	1100	1100	1100	1100	1100	1100
Height	mm	2300	2300	2300	2300	2300	2300	2300	2300

(1) Data based on 7 °C evaporating temperature and 35 °C ambient air temperature.

(2) Compressors only.

(3) Sound levels are at fully loaded conditions. Sound power level values refer to ISO standard 3744 and Eurovent 8/1.

(4) Sound pressure levels refer to ISO standard 3744, parallelepiped shape.

(*) High efficiency units (HSE) with inverter fans.

Electrical Data - VLC STD Units

Compressors @ 400 V / 3 Ph / 50 Hz

Models		Power input at nominal conditions per compressor (kW)	Current at nominal conditions per compressor (A)	Power input at max. conditions per compressor (kW)	Current at max. conditions per compressor FLA (A)	Start up current LRA (A)	Power factor at nominal conditions	Unit fuse size (A)	Cable section (mm ²)
524	Circuit 1	11.5	20	14.0	35.0	158	0.83	200	3 x 95
		11.5	20	14.0	35.0	158	0.83		
	Circuit 2	11.5	20	14.0	35.0	158	0.83		
		11.5	20	14.0	35.0	158	0.83		
604	Circuit 1	12.5	22	15.9	36.0	160	0.82	200	3 x 95
		12.5	22	15.9	36.0	160	0.82		
	Circuit 2	12.5	22	15.9	36.0	160	0.82		
		12.5	22	15.9	36.0	160	0.82		
704	Circuit 1	12.5	22	15.9	36.0	160	0.82	250	3 x 120
		17.2	28	21.5	51.0	215	0.89		
	Circuit 2	12.5	22	15.9	36.0	160	0.82		
		17.2	28	21.5	51.0	215	0.89		
804	Circuit 1	15.9	27	22.6	40.0	225	0.85	250	3 x 120
		15.9	27	22.6	40.0	225	0.85		
	Circuit 2	15.9	27	22.6	40.0	225	0.85		
		15.9	27	22.6	40.0	225	0.85		
904	Circuit 1	15.9	27	22.6	40.0	225	0.85	250	3 x 120
		22.3	36	26.0	48.5	272	0.89		
	Circuit 2	15.9	27	22.6	40.0	225	0.85		
		22.3	36	26.0	48.5	272	0.89		
1004	Circuit 1	22.3	36	26.0	48.5	272	0.89	250	3 x 120
		22.3	36	26.0	48.5	272	0.89		
	Circuit 2	22.3	36	26.0	48.5	272	0.89		
		22.3	36	26.0	48.5	272	0.89		
1104	Circuit 1	22.3	36	26.0	48.5	272	0.89	315	3 x 185
		22.3	36	26.0	48.5	272	0.89		
	Circuit 2	25.5	42	35.0	63.0	310	0.88		
		25.5	42	35.0	63.0	310	0.88		
1204	Circuit 1	25.5	42	35.0	63.0	310	0.88	315	3 x 185
		25.5	42	35.0	63.0	310	0.88		
	Circuit 2	25.5	42	35.0	63.0	310	0.88		
		25.5	42	35.0	63.0	310	0.88		

Note : The dimensioning of the unit's power cables is the responsibility of the installer, who shall consider : the rating, the maximum working temperature in the room, the type of insulation and the cable laying, the maximum length of the power supply line.

Fans - 400 V / 3 Ph / 50 Hz

VLC BLN models		524	604	704	804	904	1004	1104	1204
Number of fans		2	3	3	3	4	4	4	4
Nominal power per fan	kW	2.0	2.0	2.0	2.0	2.0	2.0	2.0	2.0
Max. running current per fan	A	4.0	4.0	4.0	4.0	4.0	4.0	4.0	4.0
Total fan power	kW	4.0	6.0	6.0	6.0	8.0	8.0	8.0	8.0
Total max. fan current	A	8.0	12.0	12.0	12.0	16.0	16.0	16.0	16.0

VLC LN models		524	604	704	804	904	1004	1104	1204
Number of fans		2	3	3	3	4	4	4	4
Nominal power per fan	kW	1.25	1.25	1.25	1.25	1.25	1.25	1.25	1.25
Max. running current per fan	A	2.3	2.3	2.3	2.3	2.3	2.3	2.3	2.3
Total fan power	kW	2.5	3.75	3.8	3.8	5.0	5.0	5.0	5.0
Total max. fan current	A	4.6	6.9	6.9	6.9	9.2	9.2	9.2	9.2

Electrical Data - VLC STD Units (continued)

Fans - 400 V / 3 Ph / 50 Hz (continued)

VLC ELN models		524	604	704	804	904	1004	1104	1204
Number of fans		2	3	3	3	4	4	4	4
Nominal power per fan	kW	1.25	1.25	1.25	1.25	1.25	1.25	1.25	1.25
Max. running current per fan	A	2.3	2.3	2.3	2.3	2.3	2.3	2.3	2.3
Total fan power	kW	2.5	3.75	3.8	3.8	5.0	5.0	5.0	5.0
Total max. fan current	A	4.6	6.9	6.9	6.9	9.2	9.2	9.2	9.2

Units - 400 V / 3 Ph / 50 Hz

VLC BLN models		524	604	704	804	904	1004	1104	1204
Nominal power input	kW	50.0	56.0	65.4	69.6	84.4	97.2	103.6	110.0
Maximum power input	kW	60.0	69.6	80.8	96.4	105.2	112.0	130.0	148.0
Nominal current input	A	88.0	100.0	112.0	120.0	142.0	160.0	172.0	184.0
Maximum current input	A	148.0	156.0	186.0	172.0	193.0	210.0	239.0	268.0
Start-up current	A	271	280	350	357	378	434	486	515

VLC LN models		524	604	704	804	904	1004	1104	1204
Nominal power input	kW	48.5	53.8	63.2	67.4	81.4	94.2	100.6	107.0
Maximum power input	kW	58.5	67.4	78.6	94.2	102.2	109.0	127.0	145.0
Nominal current input	A	84.6	94.9	106.9	114.9	135.2	153.2	165.2	177.2
Maximum current input	A	144.6	150.9	180.9	166.9	186.2	203.2	232.2	261.2
Start-up current	A	268	275	345	352	371	427	479	508

VLC ELN models		524	604	704	804	904	1004	1104	1204
Nominal power input	kW	48.5	53.8	63.2	67.4	81.4	94.2	100.6	107.0
Maximum power input	kW	58.5	67.4	78.6	94.2	102.2	109.0	127.0	145.0
Nominal current input	A	84.6	94.9	106.9	114.9	135.2	153.2	165.2	177.2
Maximum current input	A	144.6	150.9	180.9	166.9	186.2	203.2	232.2	261.2
Start-up current	A	267.6	275	345	352	371	427	479	508

Electrical Data - VLC HSE/SIF/HT Units

Compressors @ 400 V / 3 Ph / 50 Hz

Models		Power input at nominal conditions per compressor (kW)	Current at nominal conditions per compressor (A)	Power input at max. conditions per compressor (kW)	Current at max. conditions per compressor FLA (A)	Start up current LRA (A)	Power factor at nominal conditions	Unit fuse size (A)	Cable section (mm ²)
524	Circuit 1	11.5	20	14.0	35.0	158	0.83	200	3 x 95
		11.5	20	14.0	35.0	158	0.83		
	Circuit 2	11.5	20	14.0	35.0	158	0.83		
		11.5	20	14.0	35.0	158	0.83		
604	Circuit 1	12.5	22	15.9	36.0	160	0.82	200	3 x 95
		12.5	22	15.9	36.0	160	0.82		
	Circuit 2	12.5	22	15.9	36.0	160	0.82		
		12.5	22	15.9	36.0	160	0.82		
704	Circuit 1	12.5	22	15.9	36.0	160	0.82	250	3 x 120
		17.2	28	21.5	51.0	215	0.89		
	Circuit 2	12.5	22	15.9	36.0	160	0.82		
		17.2	28	21.5	51.0	215	0.89		
804	Circuit 1	15.9	27	22.6	40.0	225	0.85	250	3 x 120
		15.9	27	22.6	40.0	225	0.85		
	Circuit 2	15.9	27	22.6	40.0	225	0.85		
		15.9	27	22.6	40.0	225	0.85		
904	Circuit 1	15.9	27	22.6	40.0	225	0.85	250	3 x 120
		22.3	36	26.0	48.5	272	0.89		
	Circuit 2	15.9	27	22.6	40.0	225	0.85		
		22.3	36	26.0	48.5	272	0.89		
1004	Circuit 1	22.3	36	26.0	48.5	272	0.89	250	3 x 120
		22.3	36	26.0	48.5	272	0.89		
	Circuit 2	22.3	36	26.0	48.5	272	0.89		
		22.3	36	26.0	48.5	272	0.89		
1104	Circuit 1	22.3	36	26.0	48.5	272	0.89	315	3 x 185
		22.3	36	26.0	48.5	272	0.89		
	Circuit 2	25.5	42	35.0	63.0	310	0.88		
		25.5	42	35.0	63.0	310	0.88		
1204	Circuit 1	25.5	42	35.0	63.0	310	0.88	315	3 x 185
		25.5	42	35.0	63.0	310	0.88		
	Circuit 2	25.5	42	35.0	63.0	310	0.88		
		25.5	42	35.0	63.0	310	0.88		

Note : The dimensioning of the unit's power cables is the responsibility of the installer, who shall consider : the rating, the maximum working temperature in the room, the type of insulation and the cable laying, the maximum length of the power supply line.

Fans - 400 V / 3 Ph / 50 Hz

VLC BLN models		524	604	704	804	904	1004	1104	1204
Number of fans		2	3	3	3	4	4	4	4
Nominal power per fan	kW	2.6	2.6	2.6	2.6	2.6	2.6	2.6	2.6
Max. running current per fan	A	4.1	4.1	4.1	4.1	4.1	4.1	4.1	4.1
Total fan power	kW	5.2	7.8	7.8	7.8	10.4	10.4	10.4	10.4
Total max. fan current	A	8.2	12.3	12.3	12.3	16.4	16.4	16.4	16.4

VLC LN models		524	604	704	804	904	1004	1104	1204
Number of fans		2	3	3	3	4	4	4	4
Nominal power per fan	kW	2.6	2.6	2.6	2.6	2.6	2.6	2.6	2.6
Max. running current per fan	A	4.1	4.1	4.1	4.1	4.1	4.1	4.1	4.1
Total fan power	kW	5.2	7.8	7.8	7.8	10.4	10.4	10.4	10.4
Total max. fan current	A	8.2	12.3	12.3	12.3	16.4	16.4	16.4	16.4

Electrical Data - VLC HSE/SIF/HT Units (continued)

Fans - 400 V / 3 Ph / 50 Hz (continued)

VLC ELN models		524	604	704	804	904	1004	1104	1204
Number of fans		2	3	3	3	4	4	4	4
Nominal power per fan	kW	2.6	2.6	2.6	2.6	2.6	2.6	2.6	2.6
Max. running current per fan	A	4.1	4.1	4.1	4.1	4.1	4.1	4.1	4.1
Total fan power	kW	5.2	7.8	7.8	7.8	10.4	10.4	10.4	10.4
Total max. fan current	A	8.2	12.3	12.3	12.3	16.4	16.4	16.4	16.4

Units - 400 V / 3 Ph / 50 Hz

VLC BLN models		524	604	704	804	904	1004	1104	1204
Nominal power input	kW	51.2	57.8	67.2	71.4	86.8	99.6	106.0	112.4
Maximum power input	kW	61.2	71.4	82.6	98.2	107.6	114.4	132.4	150.4
Nominal current input	A	88.2	100.3	112.3	120.3	142.4	160.4	172.4	184.4
Maximum current input	A	148.2	156.3	186.3	172.3	193.4	210.4	239.4	268.4
Start-up current	A	271	280	350	357	378	434	486	515

VLC LN models		524	604	704	804	904	1004	1104	1204
Nominal power input	kW	51.2	57.8	67.2	71.4	86.8	99.6	106.0	112.4
Maximum power input	kW	61.2	71.4	82.6	98.2	107.6	114.4	132.4	150.4
Nominal current input	A	88.2	100.3	112.3	120.3	142.4	160.4	172.4	184.4
Maximum current input	A	148.2	156.3	186.3	172.3	193.4	210.4	239.4	268.4
Start-up current	A	271	280	350	357	378	434	486	515

VLC ELN models		524	604	704	804	904	1004	1104	1204
Nominal power input	kW	51.2	57.8	67.2	71.4	86.8	99.6	106.0	112.4
Maximum power input	kW	61.2	71.4	82.6	98.2	107.6	114.4	132.4	150.4
Nominal current input	A	88.2	100.3	112.3	120.3	142.4	160.4	172.4	184.4
Maximum current input	A	148.2	156.3	186.3	172.3	193.4	210.4	239.4	268.4
Start-up current	A	271	280	350	357	378	434	486	515

Sound Levels

		Frequency (Hz)							Sound Power dB(A)	Sound Pressure dB(A)(*)
		125	250	500	1000	2000	4000	8000		
VLC BLN	524	86.0	85.0	93.0	87.0	81.0	66.0	54.0	92	60
	604	87.0	86.0	94.0	88.0	82.0	67.0	55.0	93	61
	704	87.0	86.0	94.0	88.0	82.0	67.0	55.0	93	61
	804	87.0	86.0	94.0	88.0	82.0	67.0	55.0	93	61
	904	88.0	87.0	95.0	89.0	83.0	68.0	56.0	94	62
	1004	88.0	87.0	95.0	89.0	83.0	68.0	56.0	94	62
	1104	89.0	88.0	96.0	90.0	84.0	69.0	57.0	95	63
	1204	89.0	88.0	96.0	90.0	84.0	69.0	57.0	95	63
VLC LN	524	80.0	79.0	87.0	81.0	75.0	60.0	48.0	86	54
	604	81.0	80.0	88.0	82.0	76.0	61.0	49.0	87	55
	704	81.0	80.0	88.0	82.0	76.0	61.0	49.0	87	55
	804	81.0	80.0	88.0	82.0	76.0	61.0	49.0	87	55
	904	82.0	81.0	89.0	83.0	77.0	62.0	50.0	88	56
	1004	82.0	81.0	89.0	83.0	77.0	62.0	50.0	88	56
	1104	83.0	82.0	90.0	84.0	78.0	63.0	51.0	89	57
	1204	83.0	82.0	90.0	84.0	78.0	63.0	51.0	89	57
VLC ELN	524	77.0	76.0	84.0	78.0	72.0	57.0	45.0	83	51
	604	77.0	76.0	84.0	78.0	72.0	57.0	45.0	83	51
	704	77.0	76.0	84.0	78.0	72.0	57.0	45.0	83	51
	804	77.0	76.0	84.0	78.0	72.0	57.0	45.0	83	51
	904	78.0	77.0	85.0	79.0	73.0	58.0	46.0	84	52
	1004	78.0	77.0	85.0	79.0	73.0	58.0	46.0	84	52
	1104	79.0	78.0	86.0	80.0	74.0	59.0	47.0	85	53
	1204	79.0	78.0	86.0	80.0	74.0	59.0	47.0	85	53
VLC HT (**)	524	91.0	90.0	98.0	92.0	86.0	71.0	59.0	97	65
	604	93.0	92.0	100.0	94.0	88.0	73.0	61.0	99	67
	704	93.0	92.0	100.0	94.0	88.0	73.0	61.0	99	67
	804	93.0	92.0	100.0	94.0	88.0	73.0	61.0	99	67
	904	94.0	93.0	101.0	95.0	89.0	74.0	62.0	100	68
	1004	94.0	93.0	101.0	95.0	89.0	74.0	62.0	100	68
	1104	94.0	93.0	101.0	95.0	89.0	74.0	62.0	100	68
	1204	94.0	93.0	101.0	95.0	89.0	74.0	62.0	100	68

(*) Sound pressure levels are given at 10 meters distance according to ISO standard 3744 with parallelepiped shape.

(**) Sound data is given at maximum operating air temperature. For nominal condition, please refer to sound data of BLN version.

Cooling Capacities - VLC STD/HSE/SIF - BLN Version

Models	Evap. Temp. (°C)	Condensing Air Temperature (°C)													
		25		30		32		35		40		44		46	
		Cool. cap. (kW)	Input Power (kW)	Cool. cap. (kW)	Input Power (kW)	Cool. cap. (kW)	Input Power (kW)	Cool. cap. (kW)	Input Power (kW)	Cool. cap. (kW)	Input Power (kW)	Cool. cap. (kW)	Input Power (kW)	Cool. cap. (kW)	Input Power (kW)
524 BLN	2	151.7	37.6	144.4	41.2	141.3	42.8	136.6	45.0	127.0	49.9	121.0	53.1	115.1	56.2
	3	155.5	38.0	148.0	41.7	144.9	43.2	140.0	45.5	130.2	50.4	124.1	53.6	118.0	56.8
	4	159.4	38.5	151.7	42.2	148.4	43.7	143.6	45.9	133.5	50.9	127.2	54.1	121.0	57.3
	5	163.2	39.0	155.3	42.6	152.0	44.2	147.0	46.5	136.5	51.4	130.2	54.6	123.9	57.9
	7	171.0	39.9	162.7	43.7	159.3	45.2	154.0	47.5	143.1	52.5	136.4	55.8	129.7	59.1
	10	182.6	41.5	173.9	45.2	170.2	46.8	164.4	49.1	152.9	54.2	145.7	57.5	138.6	60.8
604 BLN	2	171.4	41.6	163.1	45.6	159.6	47.3	154.4	49.7	143.5	55.2	136.8	58.7	130.1	62.2
	3	175.7	42.1	167.2	46.1	163.7	47.8	158.2	50.3	147.1	55.7	140.2	59.2	133.4	62.7
	4	180.1	42.6	171.4	46.6	167.7	48.3	162.2	50.8	150.8	56.3	143.8	59.8	136.7	63.3
	5	184.4	43.1	175.5	47.1	171.8	48.9	166.1	51.4	154.2	56.8	147.1	60.4	139.9	64.0
	7	193.2	44.2	183.8	48.3	180.0	50.0	174.0	52.5	161.7	58.1	154.1	61.7	146.5	65.3
	10	206.4	45.9	196.5	49.9	192.3	51.7	185.8	54.3	172.8	59.9	164.7	63.5	156.6	67.2
704 BLN	2	196.1	49.9	186.5	54.7	182.6	56.7	176.5	59.7	164.1	66.2	156.4	70.4	148.8	74.6
	3	201.0	50.5	191.3	55.3	187.3	57.3	181.0	60.3	168.3	66.8	160.4	71.1	152.5	75.3
	4	206.0	51.1	196.0	56.0	191.8	58.0	185.6	60.9	172.5	67.5	164.4	71.8	156.4	76.0
	5	210.9	51.7	200.7	56.6	196.4	58.6	190.0	61.7	176.4	68.2	168.2	72.5	160.1	76.8
	7	221.0	53.0	210.2	57.9	205.8	60.0	199.0	63.0	184.9	69.7	176.3	74.0	167.6	78.3
	10	236.0	55.0	224.7	59.9	219.9	62.0	212.5	65.2	197.6	71.9	188.3	76.2	179.0	80.6
804 BLN	2	220.7	54.6	210.0	59.9	205.5	62.1	198.7	65.4	184.7	72.5	176.1	77.1	167.5	81.7
	3	226.2	55.3	215.3	60.6	210.8	62.8	203.7	66.1	189.4	73.2	180.6	77.8	171.7	82.5
	4	231.9	55.9	220.6	61.3	215.8	63.5	208.9	66.7	194.2	73.9	185.1	78.6	176.0	83.2
	5	237.4	56.7	225.9	61.9	221.1	64.2	213.8	67.5	198.6	74.7	189.4	79.4	180.2	84.1
	7	248.7	58.0	236.6	63.5	231.7	65.7	224.0	69.0	208.2	76.3	198.4	81.1	188.6	85.8
	10	265.6	60.3	252.9	65.6	247.6	67.9	239.2	71.4	222.5	78.7	212.0	83.5	201.5	88.3
904 BLN	2	254.2	62.5	241.8	68.6	236.7	71.1	228.9	74.8	212.7	83.0	202.8	88.3	192.9	93.5
	3	260.6	63.3	248.0	69.3	242.8	71.9	234.6	75.7	218.1	83.8	208.0	89.1	197.8	94.4
	4	267.1	64.0	254.1	70.2	248.6	72.7	240.6	76.4	223.6	84.7	213.2	90.0	202.7	95.3
	5	273.4	64.9	260.2	70.9	254.7	73.5	246.3	77.3	228.7	85.5	218.1	90.9	207.5	96.3
	7	286.5	66.4	272.5	72.7	266.9	75.2	258.0	79.0	239.8	87.4	228.5	92.8	217.3	98.2
	10	306.0	69.0	291.3	75.2	285.1	77.8	275.5	81.7	256.2	90.1	244.2	95.6	232.1	101.1
1004 BLN	2	278.8	65.7	265.3	72.1	259.6	74.7	251.1	78.6	233.3	87.2	222.4	92.8	211.6	98.3
	3	285.8	66.5	272.0	72.8	266.3	75.5	257.3	79.5	239.3	88.1	228.1	93.6	216.9	99.2
	4	292.9	67.3	278.7	73.7	272.7	76.4	263.9	80.3	245.3	88.9	233.8	94.5	222.3	100.1
	5	299.9	68.1	285.4	74.5	279.4	77.2	270.2	81.2	250.9	89.8	239.2	95.5	227.6	101.1
	7	314.2	69.8	298.9	76.3	292.7	79.0	283.0	83.0	263.0	91.8	250.7	97.5	238.3	103.2
	10	335.6	72.5	319.5	79.0	312.8	81.7	302.2	85.9	281.0	94.7	267.8	100.5	254.6	106.2
1104 BLN	2	310.3	77.6	295.3	85.1	289.0	88.2	279.4	92.8	259.7	103.0	247.6	109.5	235.5	116.0
	3	318.1	78.5	302.8	86.0	296.4	89.1	286.4	93.9	266.3	104.0	253.9	110.5	241.5	117.1
	4	326.1	79.4	310.2	87.0	303.5	90.2	293.7	94.8	273.0	105.0	260.3	111.6	247.5	118.2
	5	333.8	80.5	317.7	88.0	310.9	91.2	300.7	95.9	279.2	106.1	266.3	112.7	253.4	119.4
	7	349.8	82.4	332.8	90.1	325.8	93.3	315.0	98.0	292.7	108.4	279.0	115.1	265.3	121.9
	10	373.6	85.6	355.7	93.2	348.1	96.5	336.3	101.4	312.8	111.8	298.1	118.6	283.4	125.4
1204 BLN	2	341.9	88.6	325.3	97.2	318.3	100.8	307.8	106.1	286.1	117.7	272.8	125.2	259.4	132.6
	3	350.4	89.7	333.5	98.3	326.5	101.9	315.5	107.3	293.4	118.8	279.7	126.3	266.0	133.9
	4	359.2	90.8	341.7	99.5	334.4	103.1	323.6	108.3	300.8	120.0	286.7	127.6	272.6	135.1
	5	367.8	92.0	350.0	100.5	342.5	104.2	331.3	109.6	307.6	121.2	293.3	128.8	279.1	136.5
	7	385.3	94.2	366.6	103.0	358.9	106.6	347.0	112.0	322.5	123.9	307.3	131.6	292.2	139.3
	10	411.5	97.8	391.8	106.6	383.5	110.3	370.5	115.9	344.6	127.7	328.4	135.5	312.2	143.4

Note : Power input data are given for compressors only.

Cooling Capacities - VLC STD/HSE - LN Version

Models	Evap. Temp. (°C)	Condensing Air Temperature (°C)													
		25		30		32		35		40		44		46	
		Cool. cap. (kW)	Input Power (kW)	Cool. cap. (kW)	Input Power (kW)	Cool. cap. (kW)	Input Power (kW)	Cool. cap. (kW)	Input Power (kW)	Cool. cap. (kW)	Input Power (kW)	Cool. cap. (kW)	Input Power (kW)	Cool. cap. (kW)	Input Power (kW)
524 LN	2	146.8	39.6	139.7	43.4	136.7	45.0	132.2	47.4	122.8	52.6	117.1	55.9	111.4	59.2
	3	150.5	40.0	143.2	43.9	140.2	45.5	135.5	47.9	126.0	53.0	120.1	56.4	114.2	59.8
	4	154.2	40.5	146.7	44.4	143.6	46.0	138.9	48.4	129.2	53.6	123.1	56.9	117.1	60.3
	5	157.9	41.1	150.3	44.9	147.1	46.5	142.2	48.9	132.1	54.1	126.0	57.5	119.8	60.9
	7	165.4	42.1	157.4	46.0	154.1	47.6	149.0	50.0	138.5	55.3	132.0	58.7	125.5	62.2
	10	176.7	43.7	168.2	47.6	164.7	49.2	159.1	51.7	148.0	57.0	141.0	60.5	134.1	64.0
604 LN	2	166.5	43.5	158.4	47.7	155.0	49.5	149.9	52.1	139.3	57.8	132.8	61.5	126.3	65.1
	3	170.7	44.1	162.4	48.3	159.0	50.0	153.7	52.7	142.9	58.3	136.2	62.0	129.5	65.7
	4	174.9	44.6	166.4	48.8	162.8	50.6	157.6	53.2	146.5	58.9	139.6	62.6	132.8	66.3
	5	179.1	45.2	170.5	49.4	166.8	51.2	161.3	53.8	149.8	59.5	142.9	63.3	135.9	67.0
	7	187.7	46.3	178.5	50.6	174.8	52.3	169.0	55.0	157.0	60.8	149.7	64.6	142.3	68.4
	10	200.4	48.0	190.8	52.3	186.8	54.1	180.4	56.9	167.8	62.7	159.9	66.6	152.1	70.4
704 LN	2	191.1	52.2	181.8	57.3	178.0	59.4	172.1	62.5	159.9	69.4	152.5	73.8	145.0	78.1
	3	195.9	52.9	186.5	57.9	182.5	60.0	176.4	63.2	164.0	70.0	156.4	74.4	148.7	78.9
	4	200.8	53.5	191.0	58.6	186.9	60.7	180.9	63.8	168.2	70.7	160.3	75.2	152.4	79.6
	5	205.6	54.2	195.7	59.3	191.5	61.4	185.2	64.6	172.0	71.4	164.0	75.9	156.0	80.4
	7	215.4	55.5	204.9	60.7	200.7	62.8	194.0	66.0	180.3	73.0	171.8	77.5	163.4	82.1
	10	230.1	57.6	219.0	62.8	214.4	65.0	207.1	68.3	192.7	75.3	183.6	79.9	174.6	84.5
804 LN	2	214.8	57.8	204.3	63.4	200.0	65.7	193.4	69.1	179.7	76.7	171.4	81.6	163.0	86.4
	3	220.2	58.5	209.5	64.1	205.1	66.4	198.2	69.9	184.3	77.4	175.7	82.3	167.1	87.2
	4	225.7	59.2	214.7	64.8	210.1	67.2	203.3	70.6	189.0	78.2	180.1	83.1	171.3	88.1
	5	231.0	59.9	219.9	65.5	215.2	67.9	208.1	71.5	193.3	79.0	184.3	84.0	175.3	88.9
	7	242.1	61.4	230.3	67.1	225.5	69.5	218.0	73.0	202.6	80.7	193.1	85.8	183.6	90.8
	10	258.5	63.8	246.1	69.4	240.9	71.9	232.8	75.5	216.5	83.3	206.3	88.3	196.1	93.4
904 LN	2	247.3	65.7	235.3	72.1	230.3	74.7	222.7	78.6	206.9	87.2	197.3	92.8	187.7	98.3
	3	253.5	66.5	241.3	72.8	236.2	75.5	228.2	79.5	212.2	88.1	202.3	93.6	192.4	99.2
	4	259.8	67.3	247.2	73.7	241.9	76.4	234.0	80.3	217.6	88.9	207.4	94.5	197.2	100.1
	5	266.0	68.1	253.2	74.5	247.8	77.2	239.6	81.2	222.5	89.8	212.2	95.5	201.9	101.1
	7	278.7	69.8	265.1	76.3	259.6	79.0	251.0	83.0	233.2	91.8	222.3	97.5	211.4	103.2
	10	297.7	72.5	283.4	79.0	277.4	81.7	268.0	85.9	249.3	94.7	237.6	100.5	225.8	106.2
1004 LN	2	268.5	69.6	255.4	76.4	250.0	79.2	241.7	83.4	224.7	92.5	214.2	98.3	203.7	104.2
	3	275.2	70.5	261.9	77.2	256.4	80.0	247.8	84.3	230.4	93.4	219.6	99.3	208.9	105.2
	4	282.1	71.3	268.4	78.2	262.6	81.0	254.1	85.1	236.2	94.3	225.1	100.2	214.1	106.2
	5	288.8	72.2	274.8	79.0	269.0	81.9	260.1	86.1	241.6	95.3	230.4	101.2	219.2	107.2
	7	302.6	74.0	287.9	80.9	281.9	83.8	272.5	88.0	253.2	97.3	241.4	103.4	229.5	109.4
	10	323.2	76.9	307.7	83.7	301.2	86.6	291.0	91.0	270.6	100.4	257.9	106.5	245.2	112.6
1104 LN	2	296.5	82.3	282.1	90.3	276.1	93.6	267.0	98.5	248.2	109.3	236.6	116.2	225.0	123.1
	3	304.0	83.3	289.3	91.3	283.2	94.6	273.7	99.6	254.5	110.3	242.6	117.3	230.7	124.3
	4	311.6	84.3	296.4	92.4	290.0	95.7	280.7	100.6	260.9	111.5	248.7	118.5	236.5	125.5
	5	319.0	85.4	303.6	93.4	297.1	96.8	287.4	101.8	266.8	112.6	254.5	119.6	242.1	126.7
	7	334.2	87.5	318.0	95.7	311.3	99.0	301.0	104.0	279.7	115.0	266.6	122.2	253.5	129.3
	10	357.0	90.8	339.8	98.9	332.7	102.4	321.4	107.6	298.9	118.6	284.9	125.9	270.8	133.1
1204 LN	2	325.1	95.8	309.3	105.0	302.8	108.9	292.8	114.6	272.1	127.2	259.4	135.2	246.7	143.3
	3	333.3	96.9	317.2	106.2	310.5	110.1	300.1	115.9	279.0	128.4	266.0	136.5	253.0	144.6
	4	341.6	98.1	325.0	107.5	318.0	111.3	307.7	117.0	286.0	129.7	272.7	137.8	259.3	146.0
	5	349.7	99.3	332.8	108.6	325.7	112.6	315.0	118.4	292.5	131.0	279.0	139.2	265.4	147.4
	7	366.4	101.8	348.6	111.3	341.3	115.2	330.0	121.0	306.7	133.8	292.3	142.2	277.9	150.5
	10	391.4	105.7	372.6	115.1	364.7	119.1	352.3	125.2	327.7	138.0	312.3	146.4	296.9	154.9

Note : Power input data are given for compressors only.

Cooling Capacities - VLC STD/HSE - ELN Version

Models	Evap. Temp. (°C)	Condensing Air Temperature (°C)													
		25		30		32		35		40		44		46	
		Cool. cap. (kW)	Input Power (kW)	Cool. cap. (kW)	Input Power (kW)	Cool. cap. (kW)	Input Power (kW)	Cool. cap. (kW)	Input Power (kW)	Cool. cap. (kW)	Input Power (kW)	Cool. cap. (kW)	Input Power (kW)	Cool. cap. (kW)	Input Power (kW)
524 ELN	2	141.9	41.6	135.0	45.6	132.1	47.3	127.7	49.7	118.7	55.2	113.2	58.7	107.7	62.2
	3	145.4	42.1	138.4	46.1	135.5	47.8	130.9	50.3	121.8	55.7	116.1	59.2	110.4	62.7
	4	149.1	42.6	141.8	46.6	138.8	48.3	134.3	50.8	124.8	56.3	119.0	59.8	113.1	63.3
	5	152.6	43.1	145.2	47.1	142.1	48.9	137.5	51.4	127.7	56.8	121.7	60.4	115.8	64.0
	7	159.9	44.2	152.1	48.3	148.9	50.0	144.0	52.5	133.8	58.1	127.5	61.7	121.3	65.3
	10	170.8	45.9	162.6	49.9	159.1	51.7	153.8	54.3	143.0	59.9	136.3	63.5	129.6	67.2
604 ELN	2	162.1	45.1	154.2	49.5	150.9	51.3	145.9	54.0	135.6	59.9	129.3	63.7	123.0	67.5
	3	166.1	45.7	158.1	50.0	154.8	51.8	149.6	54.6	139.1	60.5	132.6	64.3	126.1	68.1
	4	170.3	46.2	162.0	50.6	158.5	52.4	153.4	55.1	142.6	61.1	135.9	64.9	129.2	68.8
	5	174.3	46.8	165.9	51.2	162.4	53.1	157.0	55.8	145.8	61.7	139.1	65.6	132.3	69.4
	7	182.7	47.9	173.8	52.4	170.1	54.3	164.5	57.0	152.9	63.0	145.7	67.0	138.5	70.9
	10	195.1	49.8	185.7	54.2	181.8	56.1	175.6	59.0	163.4	65.0	155.7	69.0	148.0	73.0
704 ELN	2	185.7	54.6	176.7	59.9	172.9	62.1	167.2	65.4	155.4	72.5	148.2	77.1	140.9	81.7
	3	190.4	55.3	181.2	60.6	177.4	62.8	171.4	66.1	159.4	73.2	151.9	77.8	144.5	82.5
	4	195.1	55.9	185.6	61.3	181.6	63.5	175.8	66.7	163.4	73.9	155.7	78.6	148.1	83.2
	5	199.8	56.7	190.1	61.9	186.1	64.2	180.0	67.5	167.1	74.7	159.4	79.4	151.6	84.1
	7	209.3	58.0	199.1	63.5	195.0	65.7	188.5	69.0	175.2	76.3	167.0	81.1	158.7	85.8
	10	223.5	60.3	212.8	65.6	208.3	67.9	201.3	71.4	187.2	78.7	178.4	83.5	169.6	88.3
804 ELN	2	207.9	60.5	197.8	66.4	193.6	68.9	187.2	72.5	174.0	80.4	165.9	85.5	157.8	90.6
	3	213.1	61.3	202.8	67.1	198.5	69.6	191.9	73.3	178.4	81.2	170.1	86.3	161.7	91.4
	4	218.4	62.0	207.8	67.9	203.3	70.4	196.7	74.0	182.9	82.0	174.3	87.1	165.8	92.3
	5	223.6	62.8	212.8	68.7	208.3	71.2	201.4	74.9	187.0	82.8	178.4	88.0	169.7	93.2
	7	234.3	64.3	222.9	70.4	218.2	72.8	211.0	76.5	196.1	84.6	186.9	89.9	177.7	95.1
	10	250.2	66.8	238.2	72.8	233.2	75.3	225.3	79.1	209.5	87.2	199.7	92.6	189.8	97.9
904 ELN	2	240.4	68.5	228.7	75.1	223.9	77.9	216.5	81.9	201.2	90.9	191.8	96.7	182.4	102.4
	3	246.4	69.3	234.5	75.9	229.6	78.7	221.9	82.8	206.3	91.8	196.7	97.6	187.0	103.4
	4	252.6	70.1	240.3	76.8	235.1	79.6	227.5	83.7	211.5	92.7	201.6	98.5	191.7	104.3
	5	258.6	71.0	246.1	77.7	240.9	80.5	232.9	84.7	216.3	93.6	206.3	99.5	196.3	105.4
	7	270.9	72.8	257.8	79.6	252.4	82.3	244.0	86.5	226.7	95.7	216.1	101.6	205.5	107.6
	10	289.4	75.6	275.5	82.3	269.7	85.1	260.5	89.5	242.3	98.7	230.9	104.7	219.5	110.7
1004 ELN	2	260.6	72.4	247.9	79.4	242.7	82.4	234.6	86.7	218.1	96.2	207.9	102.3	197.7	108.3
	3	267.1	73.3	254.2	80.3	248.9	83.2	240.5	87.6	223.6	97.1	213.2	103.2	202.8	109.4
	4	273.8	74.2	260.5	81.3	254.9	84.2	246.6	88.5	229.3	98.1	218.5	104.2	207.8	110.4
	5	280.3	75.1	266.8	82.1	261.1	85.2	252.5	89.6	234.5	99.0	223.6	105.3	212.7	111.5
	7	293.7	77.0	279.4	84.2	273.6	87.1	264.5	91.5	245.8	101.2	234.3	107.5	222.8	113.8
	10	313.7	79.9	298.6	87.0	292.3	90.1	282.4	94.7	262.7	104.4	250.3	110.7	238.0	117.1
1104 ELN	2	287.7	85.5	273.7	93.8	267.9	97.2	259.0	102.3	240.7	113.5	229.5	120.7	218.3	127.9
	3	294.9	86.5	280.7	94.8	274.8	98.2	265.5	103.4	246.9	114.6	235.4	121.8	223.8	129.1
	4	302.3	87.5	287.6	95.9	281.4	99.4	272.3	104.5	253.1	115.7	241.3	123.0	229.4	130.3
	5	309.5	88.7	294.5	97.0	288.2	100.5	278.8	105.7	258.8	116.9	246.9	124.2	234.9	131.6
	7	324.2	90.8	308.5	99.3	302.0	102.8	292.0	108.0	271.3	119.5	258.6	126.9	245.9	134.3
	10	346.3	94.3	329.7	102.7	322.7	106.3	311.8	111.7	290.0	123.2	276.4	130.7	262.7	138.2
1204 ELN	2	314.3	100.5	299.0	110.2	292.7	114.3	283.0	120.3	263.0	133.5	250.7	141.9	238.5	150.4
	3	322.2	101.7	306.6	111.5	300.2	115.5	290.1	121.6	269.7	134.7	257.1	143.3	244.5	151.8
	4	330.2	102.9	314.1	112.8	307.4	116.9	297.5	122.9	276.5	136.1	263.6	144.6	250.6	153.2
	5	338.1	104.3	321.7	114.0	314.9	118.2	304.5	124.3	282.8	137.5	269.7	146.1	256.6	154.7
	7	354.2	106.8	337.0	116.8	330.0	120.9	319.0	127.0	296.4	140.5	282.5	149.2	268.7	157.9
	10	378.3	110.9	360.2	120.8	352.6	125.0	340.6	131.4	316.8	144.8	301.9	153.7	287.0	162.6

Note : Power input data are given for compressors only.

Cooling Capacities - VLC HT

Models	Evap. Temp. (°C)	Condensing Air Temperature (°C)													
		25		30		32		35		40		44		46	
		Cool. cap. (kW)	Input Power (kW)	Cool. cap. (kW)	Input Power (kW)	Cool. cap. (kW)	Input Power (kW)	Cool. cap. (kW)	Input Power (kW)	Cool. cap. (kW)	Input Power (kW)	Cool. cap. (kW)	Input Power (kW)	Cool. cap. (kW)	Input Power (kW)
524 HT	2	153.2	37.2	145.8	40.8	142.7	42.3	137.9	44.5	128.2	49.4	122.2	52.5	116.3	55.7
	3	157.0	37.6	149.5	41.2	146.3	42.8	141.4	45.0	131.5	49.9	125.3	53.0	119.2	56.2
	4	161.0	38.1	153.1	41.7	149.8	43.2	145.0	45.5	134.8	50.4	128.5	53.5	122.2	56.7
	5	164.8	38.6	156.8	42.2	153.5	43.7	148.4	46.0	137.8	50.9	131.5	54.1	125.1	57.3
	7	172.7	39.5	164.3	43.2	160.8	44.7	155.5	47.0	144.5	52.0	137.7	55.2	131.0	58.5
	10	184.4	41.1	175.6	44.7	171.9	46.3	166.0	48.6	154.4	53.6	147.2	56.9	139.9	60.2
604 HT	2	173.4	40.8	165.0	44.7	161.5	46.4	156.1	48.8	145.1	54.1	138.3	57.6	131.6	61.0
	3	177.7	41.3	169.2	45.2	165.6	46.8	160.0	49.3	148.8	54.6	141.9	58.1	134.9	61.6
	4	182.2	41.7	173.3	45.7	169.6	47.4	164.1	49.8	152.6	55.2	145.4	58.7	138.3	62.1
	5	186.5	42.3	177.5	46.2	173.7	47.9	168.0	50.4	156.0	55.7	148.8	59.2	141.6	62.7
	7	195.4	43.3	185.9	47.4	182.0	49.0	176.0	51.5	163.6	57.0	155.9	60.5	148.2	64.0
	10	208.7	45.0	198.7	49.0	194.5	50.7	187.9	53.3	174.8	58.7	166.6	62.3	158.4	65.9
704 HT	2	198.0	49.1	188.4	53.8	184.4	55.8	178.3	58.7	165.7	65.2	158.0	69.3	150.3	73.4
	3	203.0	49.7	193.2	54.4	189.1	56.4	182.8	59.4	169.9	65.8	162.0	69.9	154.1	74.1
	4	208.1	50.3	197.9	55.1	193.7	57.0	187.4	60.0	174.2	66.4	166.1	70.6	157.9	74.8
	5	213.0	50.9	202.7	55.7	198.4	57.7	191.9	60.7	178.2	67.1	169.9	71.3	161.7	75.5
	7	223.2	52.1	212.3	57.0	207.9	59.0	201.0	62.0	186.8	68.6	178.0	72.8	169.3	77.1
	10	238.4	54.2	226.9	59.0	222.1	61.0	214.6	64.1	199.6	70.7	190.2	75.0	180.8	79.4
804 HT	2	223.2	53.8	212.3	59.0	207.8	61.2	200.9	64.4	186.7	71.5	178.0	76.0	169.3	80.5
	3	228.7	54.5	217.7	59.7	213.1	61.9	206.0	65.1	191.5	72.1	182.6	76.7	173.6	81.3
	4	234.5	55.1	223.1	60.4	218.3	62.6	211.2	65.8	196.3	72.9	187.1	77.5	178.0	82.0
	5	240.0	55.8	228.4	61.0	223.6	63.3	216.2	66.6	200.8	73.6	191.5	78.2	182.2	82.9
	7	251.5	57.2	239.3	62.5	234.3	64.7	226.5	68.0	210.5	75.2	200.6	79.9	190.8	84.6
	10	268.6	59.4	255.7	64.7	250.3	66.9	241.8	70.4	224.9	77.6	214.4	82.3	203.8	87.0
904 HT	2	257.1	61.3	244.6	67.3	239.5	69.8	231.5	73.4	215.2	81.5	205.2	86.6	195.1	91.8
	3	263.6	62.1	250.9	68.0	245.6	70.5	237.3	74.2	220.7	82.2	210.4	87.4	200.1	92.6
	4	270.2	62.8	257.0	68.8	251.5	71.3	243.4	75.0	226.2	83.1	215.6	88.3	205.1	93.5
	5	276.6	63.6	263.2	69.6	257.6	72.1	249.2	75.9	231.4	83.9	220.6	89.2	209.9	94.4
	7	289.8	65.2	275.7	71.3	270.0	73.8	261.0	77.5	242.5	85.7	231.2	91.1	219.8	96.4
	10	309.5	67.7	294.7	73.7	288.5	76.3	278.7	80.2	259.2	88.4	247.0	93.8	234.8	99.2
1004 HT	2	282.3	64.1	268.6	70.3	262.8	72.9	254.2	76.7	236.2	85.1	225.2	90.5	214.2	95.9
	3	289.3	64.9	275.4	71.1	269.6	73.7	260.5	77.6	242.2	85.9	230.9	91.4	219.6	96.8
	4	296.6	65.7	282.1	71.9	276.1	74.5	267.1	78.4	248.3	86.8	236.7	92.3	225.1	97.7
	5	303.6	66.5	289.0	72.7	282.8	75.4	273.5	79.3	254.0	87.7	242.2	93.2	230.4	98.7
	7	318.1	68.1	302.6	74.5	296.3	77.1	286.5	81.0	266.2	89.6	253.8	95.2	241.3	100.7
	10	339.8	70.8	323.5	77.1	316.6	79.7	305.9	83.8	284.5	92.4	271.1	98.0	257.8	103.7
1104 HT	2	313.3	75.2	298.1	82.5	291.7	85.5	282.1	90.0	262.2	99.8	250.0	106.2	237.7	112.5
	3	321.2	76.1	305.7	83.4	299.2	86.4	289.2	91.0	268.9	100.8	256.3	107.2	243.8	113.5
	4	329.2	77.0	313.2	84.4	306.4	87.4	296.5	91.9	275.6	101.8	262.7	108.2	249.8	114.6
	5	337.0	78.0	320.7	85.3	313.9	88.4	303.6	93.0	281.9	102.8	268.8	109.3	255.8	115.7
	7	353.1	79.9	335.9	87.4	328.9	90.4	318.0	95.0	295.5	105.1	281.7	111.6	267.8	118.1
	10	377.1	83.0	359.0	90.4	351.5	93.5	339.5	98.3	315.8	108.3	301.0	115.0	286.1	121.6
1204 HT	2	347.8	86.3	330.9	94.6	323.9	98.1	313.2	103.2	291.0	114.6	277.5	121.8	263.9	129.1
	3	356.5	87.3	339.3	95.7	332.2	99.1	321.0	104.4	298.5	115.6	284.5	123.0	270.6	130.3
	4	365.4	88.3	347.6	96.8	340.1	100.3	329.2	105.4	306.0	116.8	291.7	124.1	277.3	131.5
	5	374.1	89.5	356.0	97.9	348.5	101.4	337.0	106.7	312.9	118.0	298.4	125.4	283.9	132.8
	7	392.0	91.7	372.9	100.3	365.1	103.7	353.0	109.0	328.0	120.6	312.7	128.1	297.3	135.6
	10	418.6	95.2	398.6	103.7	390.1	107.3	376.9	112.8	350.6	124.3	334.1	131.9	317.6	139.5

Note : Power input data are given for compressors only.

Dimensions

Models VLC 524 & 604

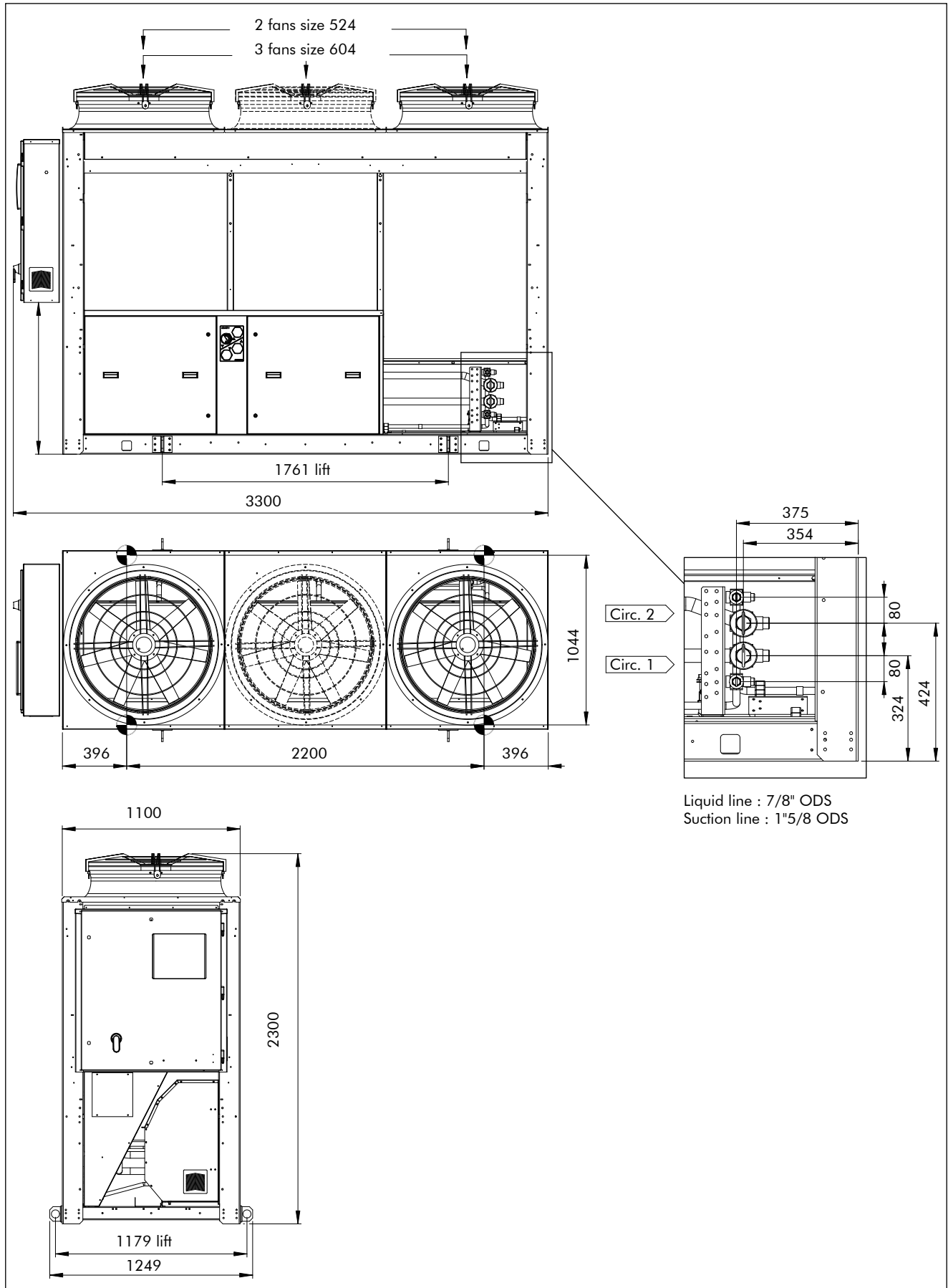

Dimensions (continued)

Models VLC 704 to 1204

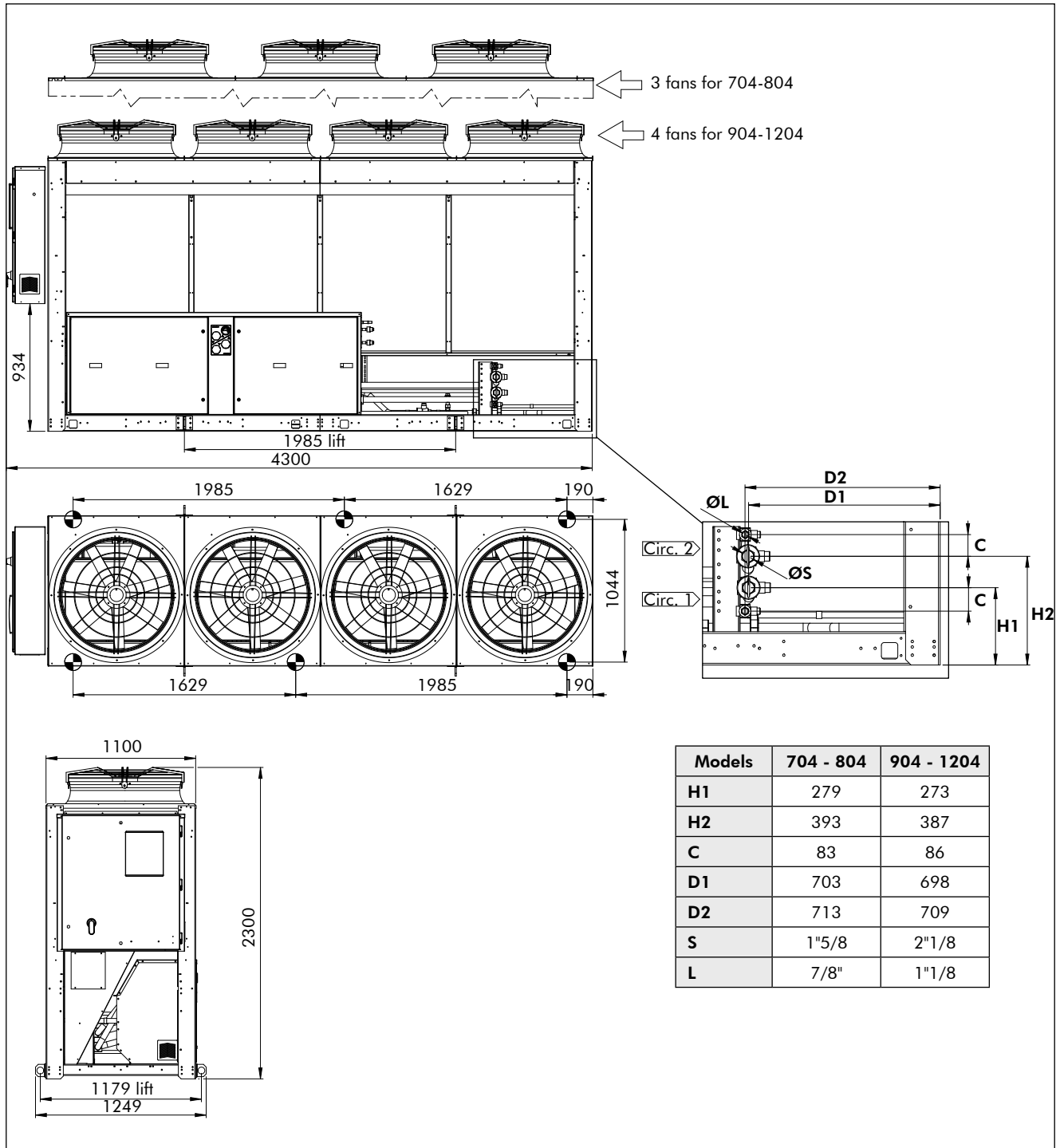

Space Requirements

Single unit applications

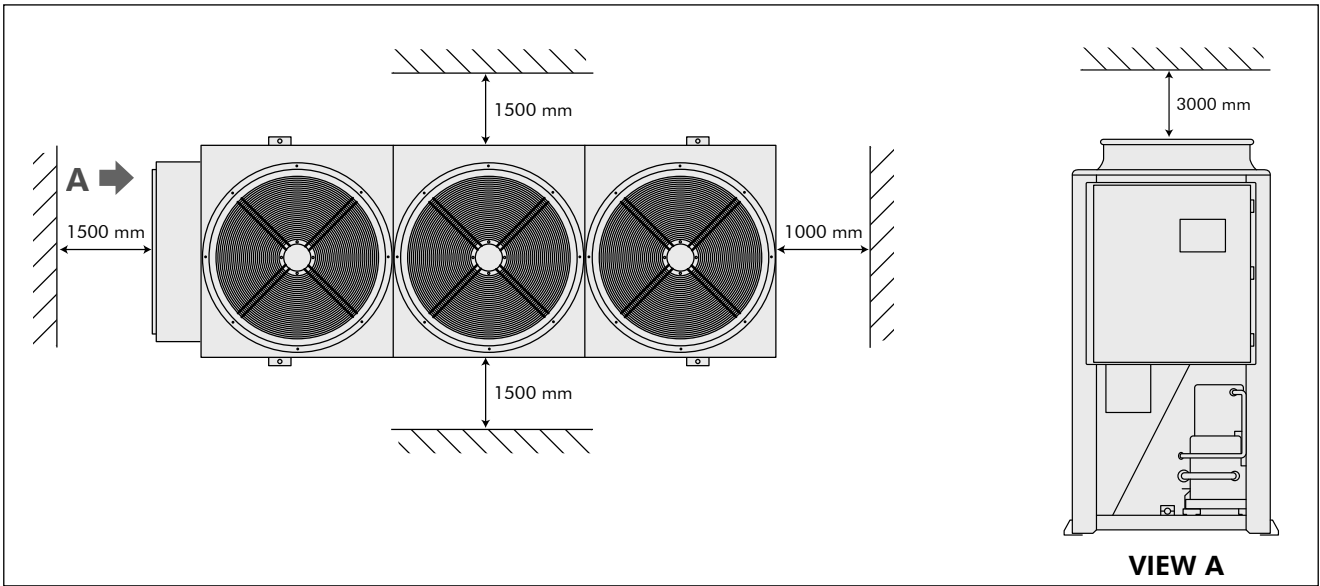

Multi units applications

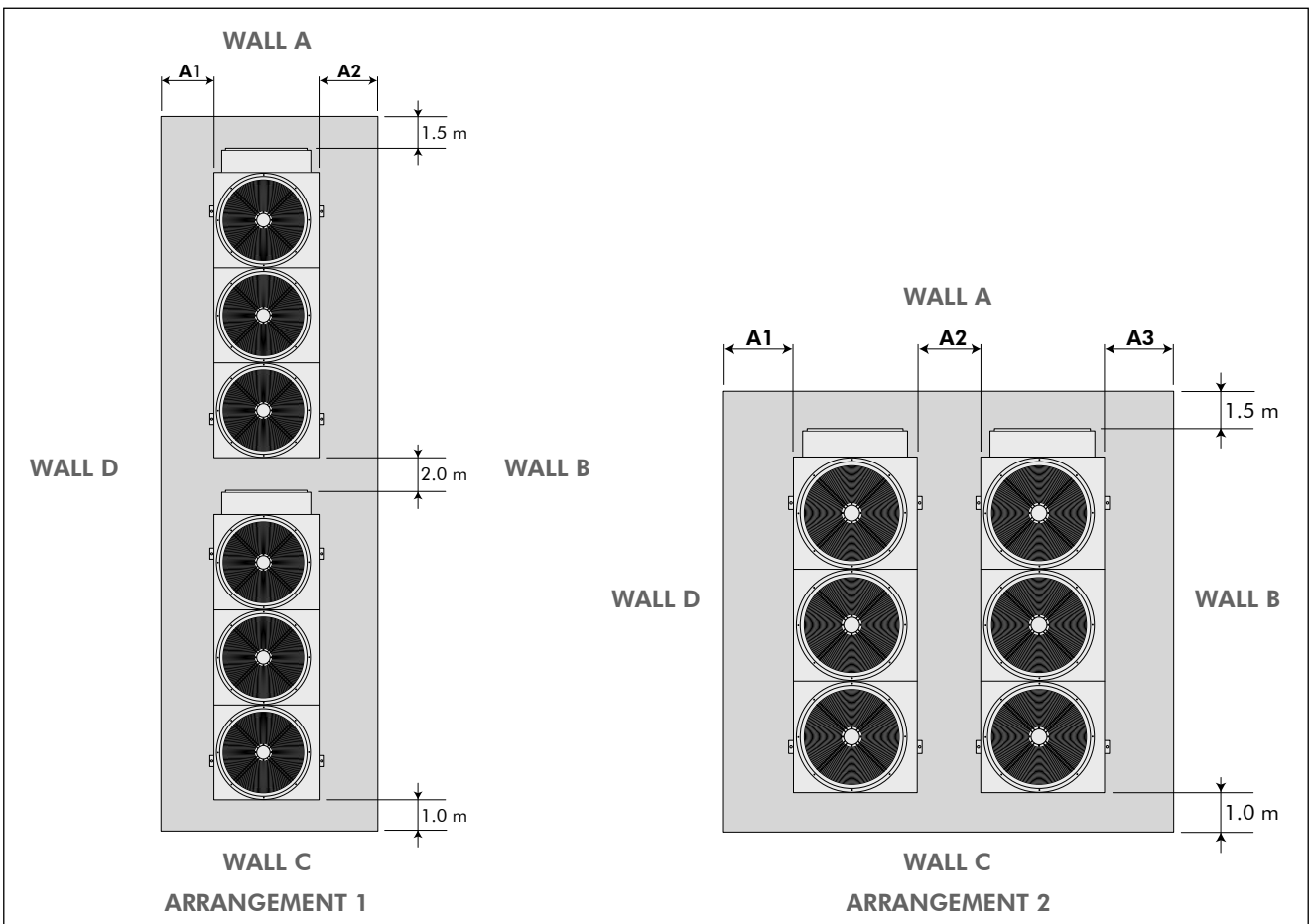

	LOUVRED A & C SOLID B & D			SOLID A & B SOLID C & D			SOLID A & C LOUVRED B & D			LOUVRED A & B SOLID C & D			LOUVRED A & D SOLID B & C		
	A1	A2	A3	A1	A2	A3	A1	A2	A3	A1	A2	A3	A1	A2	A3
ARRANGEMENT 1	1000	1000		1000	1000		800	800		1000	800		800	1000	
ARRANGEMENT 2	1000	1500	1000	1000	2000	1000	800	2000	800	1000	1500	800	800	1500	1000

Note : No more than one wall can be higher than the unit.
The area enclosed by the wall must be kept clear of all obstructions that would impede air flow to the unit.
Dimensions in mm.

Note

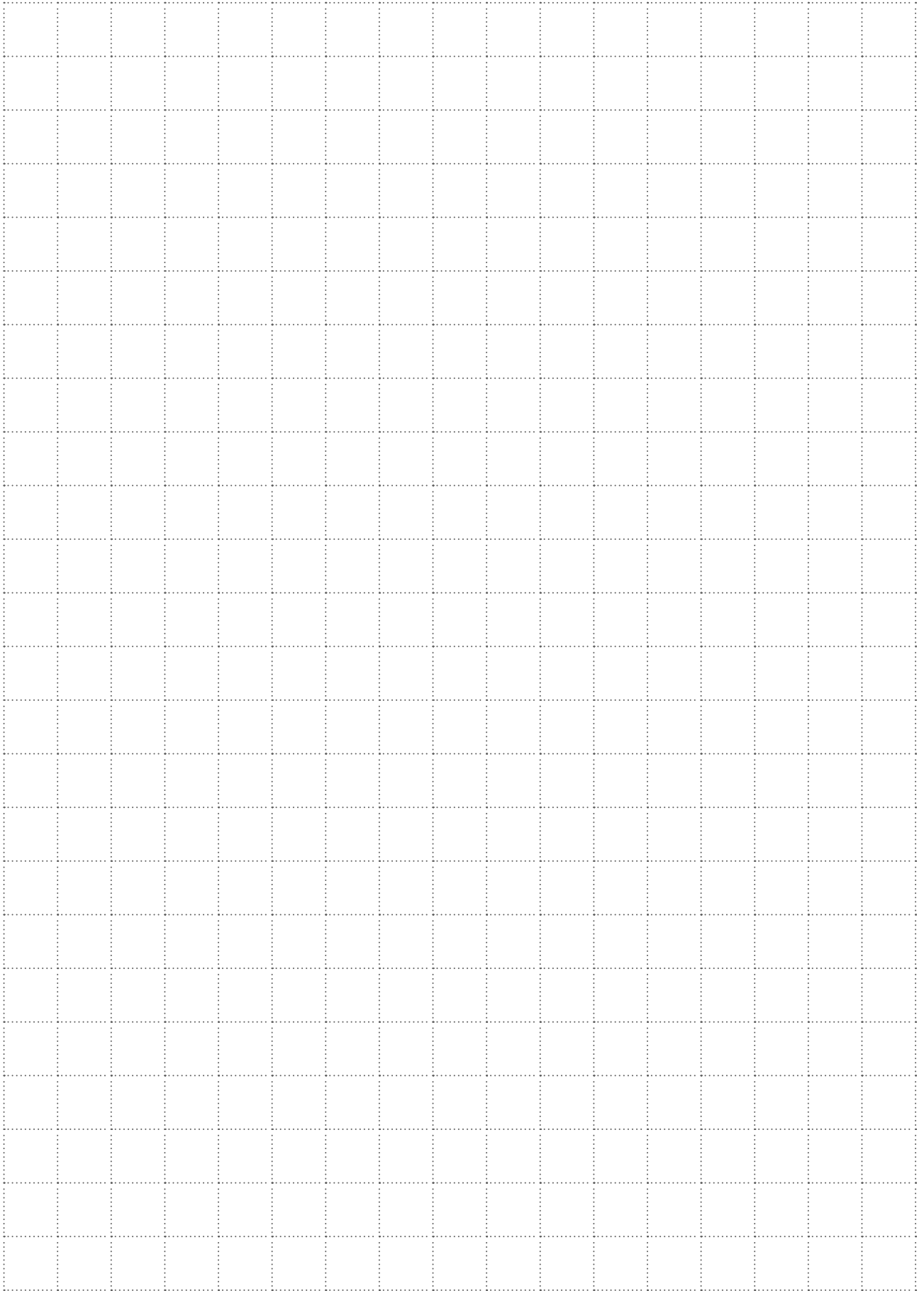

Note

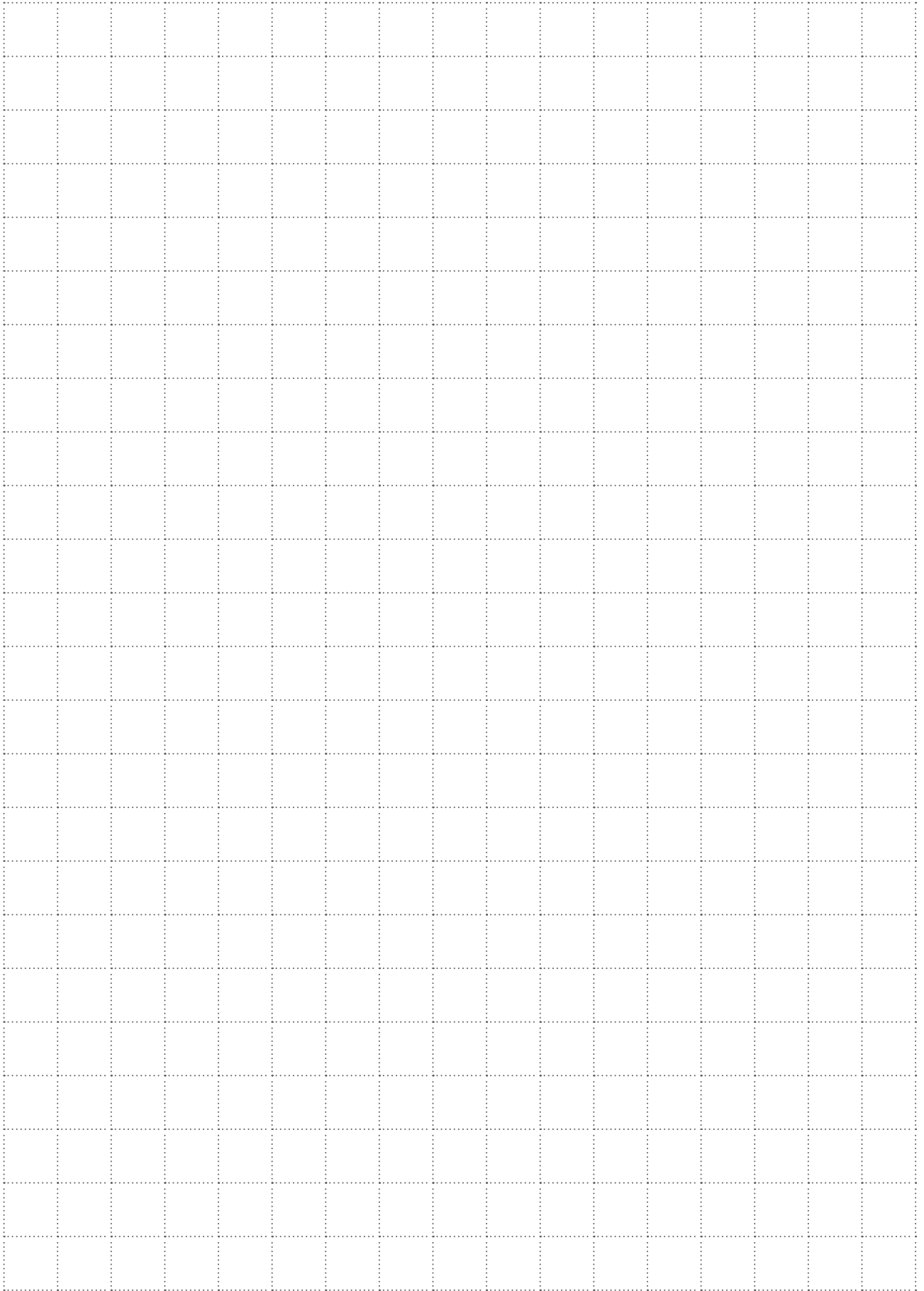

Airwell

As part of our ongoing product improvement programme, our products are subject to change without prior notice. Non contractual photos.



CAC Export Department
42 cours Jean-Jaurès
17800 Pons - France
Tel. : +33 (0)5 46 92 33 33 - Fax : +33 (0)5 46 91 26 44

Your distributor :