



Self-consumption & energy storage



victron energy
BLUE POWER





INDEX

Introduction	4
Why choose Victron Energy for your Energy Storage system	6
Victron Training in a cabinet ESS / Off Grid / 3Phase	8
Which system to choose	10
Monitoring	12
Tools	14
Accessories	15
Technical information	19
About Victron Energy	62



Self-consumption or grid independence

The primary goal of a self-consumption system is to optimise the use of solar and/or wind power. The major obstacle in such a system is that power generation times do not match with the actual times of power use. This results in a system being forced to import energy from the grid and export it when there is a surplus.

In an optimised self-consumption system, surplus energy is stored locally for local on demand use. Such energy storage is becoming an increasingly attractive proposition, especially with feed-in tariffs decreasing and grid supplies becoming less stable and more expensive.

Self-consumption versus off-grid systems

There are some major considerations which should be taken into account when comparing an off-grid system with a self-consumption system.

An off-grid system is a system that is not (or mostly not) connected to grid power and is used to supply the total energy needs of the complete energy system. Therefore it is sized to cope in a worst case scenario. This worst case scenario can occur when there is simultaneous usage of high loads which then requires a high power inverter for occasional use.

The other worst case scenario is the lack of ability to generate energy in periods of overcast weather and/or wind outages. This results in substantial battery storage to overcome this, which, like the large inverter power situation mentioned above, is only used on occasion.

In general it can therefore be stated that an off-grid system is oversized in both inverter power and storage capacity in order to deal with such situations.

For a self-consumption system this is different, as there is always a grid present. With Grid assist functionality the grid can be used seamlessly, whenever there is a high peak load, meaning the inverter can be sized according to the base load.

The base load is the part of the total energy-need which generally comes from low powered equipment and these loads continue to draw energy almost constantly over the 24 hours of a day.

Examples of this are heating pumps, chargers and the standby power of household equipment. In order to optimise PV usage and limit the import of energy this base-load is the most efficient part to target.

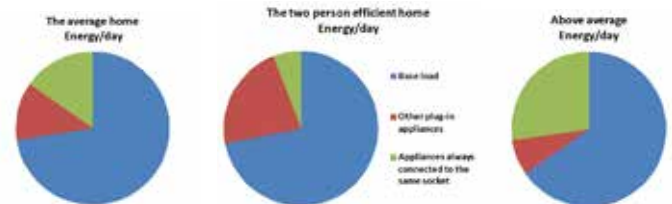

Avoiding the import of the total energy need is possible but this would require a higher investment in the inverter, as it must then be able to cover for high loads. Most high loads are however peak loads and active over a limited period of time. So even though this requires a high energy supply, the time period is limited and the energy value within this peak load period is quite low - so the investment in a larger inverter is often not justified.

When considering battery capacity, a self-consumption system is able to work with a smaller battery capacity. The energy stored in such a system is limited to the surplus PV power as part of the generated PV power is directly used by the loads. In this case PV power is sized according to the base load and any surplus energy is used overnight.



Why choose Victron Energy for your Energy Storage system



A wide range of inverter/charger sizes and configurations

Our inverter/charger models range from a small 500VA unit all the way up to a 15kVA unit. Multiple units can be connected in parallel and/or 3-phase configuration. Thus it is possible to create systems ranging in power size from a small single phase system up to an impressive 180kVA 3-phase system.



Reinout Vader showing first inverter

Unrivalled experience with battery storage systems

Victron Energy was founded in 1973, back then we started with providing inverters and chargers for the marine industry. This quickly expanded to the land based and automotive market. We therefore have an unrivalled length of experience with battery storage systems.

DC-Coupled PV or AC-Coupled PV. Or even a combination of both

We can work with DC-Coupled PV: MPPT solar chargers. We have a broad range of efficient MPPT solar chargers. Starting from the MPPT 75V/10A (290 W charger) up to the 450/200 (11,5kW solar charger).

We can also work with AC-Coupled PV etc. We are compatible with many brands of PV Inverters; with a strong collaboration with Fronius PV Inverters.

We can even combine AC and DC coupled PV in one system.



Excellent remote monitoring and diagnostics tools

Our remote monitoring website (VRM) can display all your systems data in a comprehensive graphical format. System settings can be changed via the portal. Alarms can be received by e-mail.





UPS no-break output, operate without any disruption

Our inverter/charger takes over supplying power to the connected loads in the event of a grid or generator failure. This happens so fast (less than 20 milliseconds) that computers and other electronic equipment will continue to operate without any disruption.



Wide range of compatible battery technologies

We sell our own brand of lead acid and lithium batteries. Also, our programmable inverter/chargers work with a wide range of battery technologies, see the logos below.

Battery technologies we work with:



And many more!



Victron Ambassador Markus Pauritsch has packed a 3-Phase ESS Off-Grid energy system into a stylish cabinet which he uses for training. The fully operational cabinet demonstrates the features of a full-scale static installation. It includes Lithium battery storage with a battery management system; three-phase power from MultiPlus II units - plus integration with a third party 'Fronius' three phase inverter; energy metering - low-voltage battery protection ...and monitoring from anywhere in the world.

So what is happening on the inside?

Packed into the case there's a 9000VA 3-phase ESS system including 10kW/h battery storage:

3 x MultiPlus-II 48/3000/35-32

SmartSolar MPPT 150/45-Tr

Cerbo GX

GX Touch 50

Fronius Symo 3.0-3- M

Energy meter EM24 – 3 phase – max. 64A/phase

2 x LiFePO4 Batteries 25,6V/200Ah smart.

VE.Bus BMS

Orion-Tr 48/12-9A (110W)

Smart BatteryProtect 48V-100A

Battery Monitor BMV-712 Smart, together with all necessary Fuses, cables and Busbars.

The fully functioning cabinet is designed to work like this: 5.1kWp solar modules feed both the Fronius Inverter and the SmartSolar MPPT. Four AC powered fans mounted in the cabinet-roof provide ventilation and control internal temperature. Excess PV power can be used for water heating using 48V DC immersion heaters. The 48V-100A Smart BatteryProtect will turn the water heating elements on/off, so

there's no risk of melting relay contacts.

The cabinet is fitted with RGB LED downlighting. A Wi-Fi enabled controller operates the LED strips – and a neat enhancement is that it is possible to change lighting colours according to system conditions (State of Charge; warnings and alarms, etc.) via Node-RED.

The default setup of the 3-Phase AC and DC coupled cabinet is as an ESS, but it can easily reconfigured to an Off-Grid system. Markus uses the cabinet for training sessions on Power Calculation; System configuration; Tips and tricks regarding cable calculations; and Troubleshooting - and when not in use he employs the cabinet installation in his own house!

Markus Pauritsch shows us the GX Touch 50 which provides at-a-glance system information and access to settings of his 3-phase training cabinet.



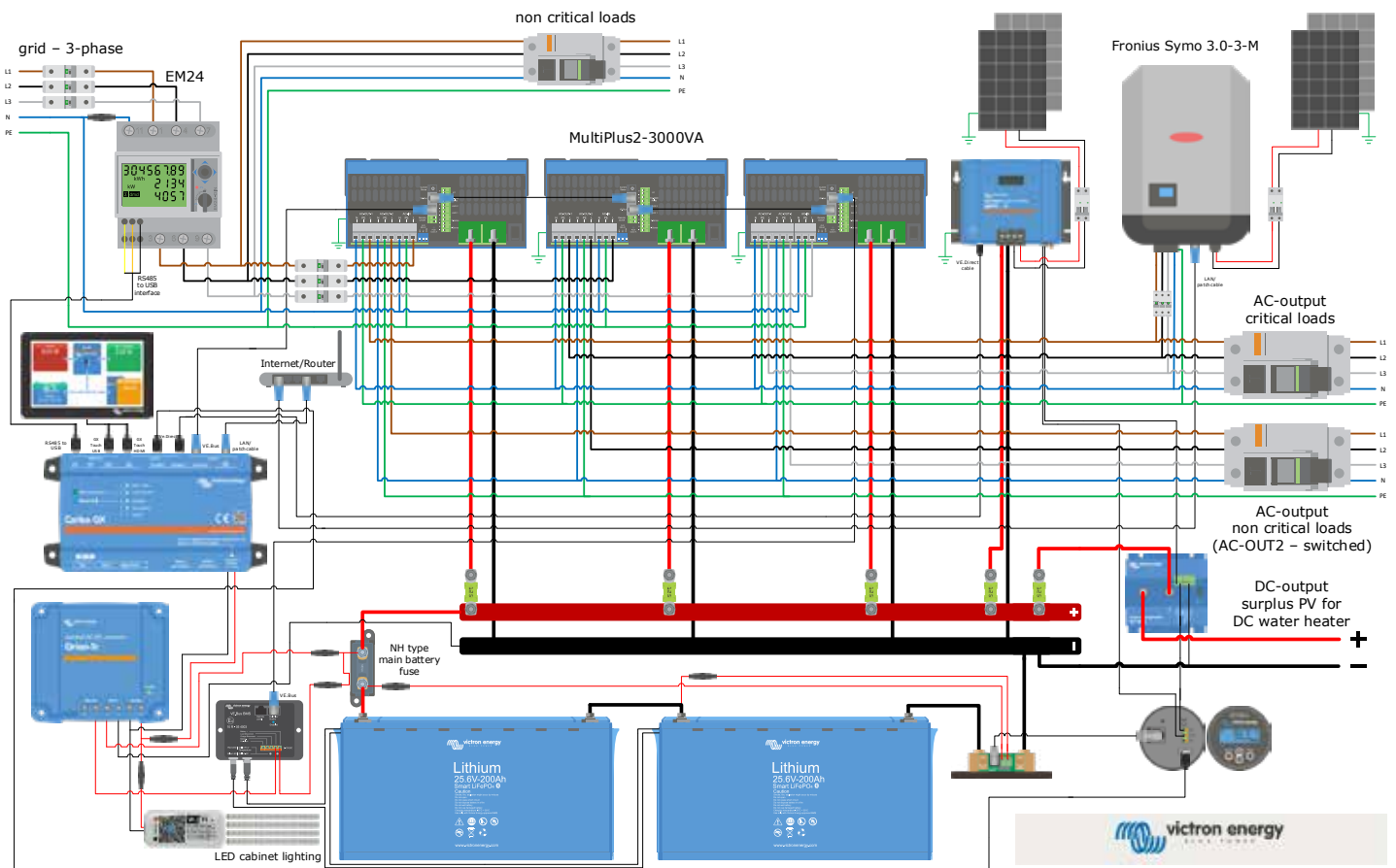

Which system to choose

There is a solution for every situation, from simple to more complex solutions. We have different options available: PV in parallel, AC-Coupled PV, DC-Coupled PV or a combination of all these options.

Option 1: PV in parallel

Most practical solution to add battery storage to an existing grid connected PV system.

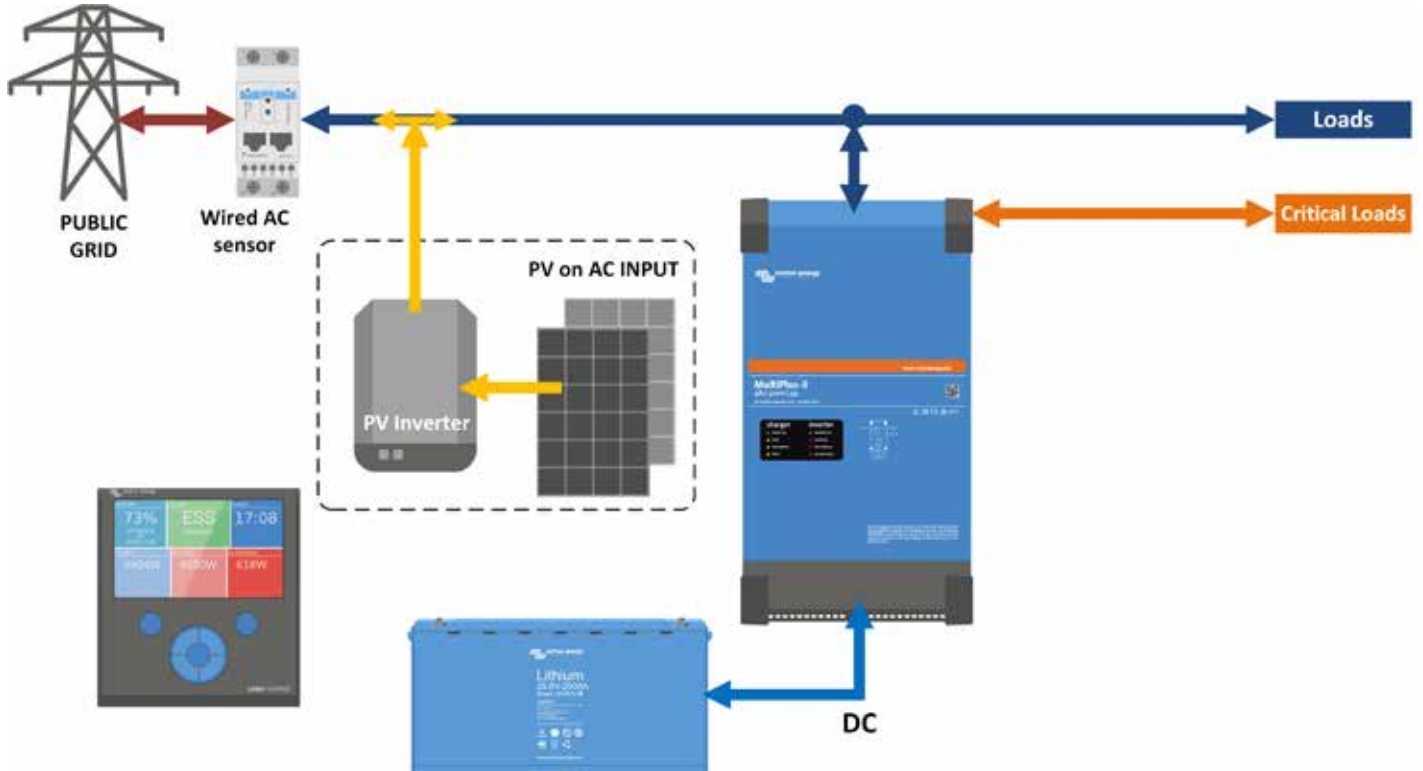

Option 2: AC-Coupled PV

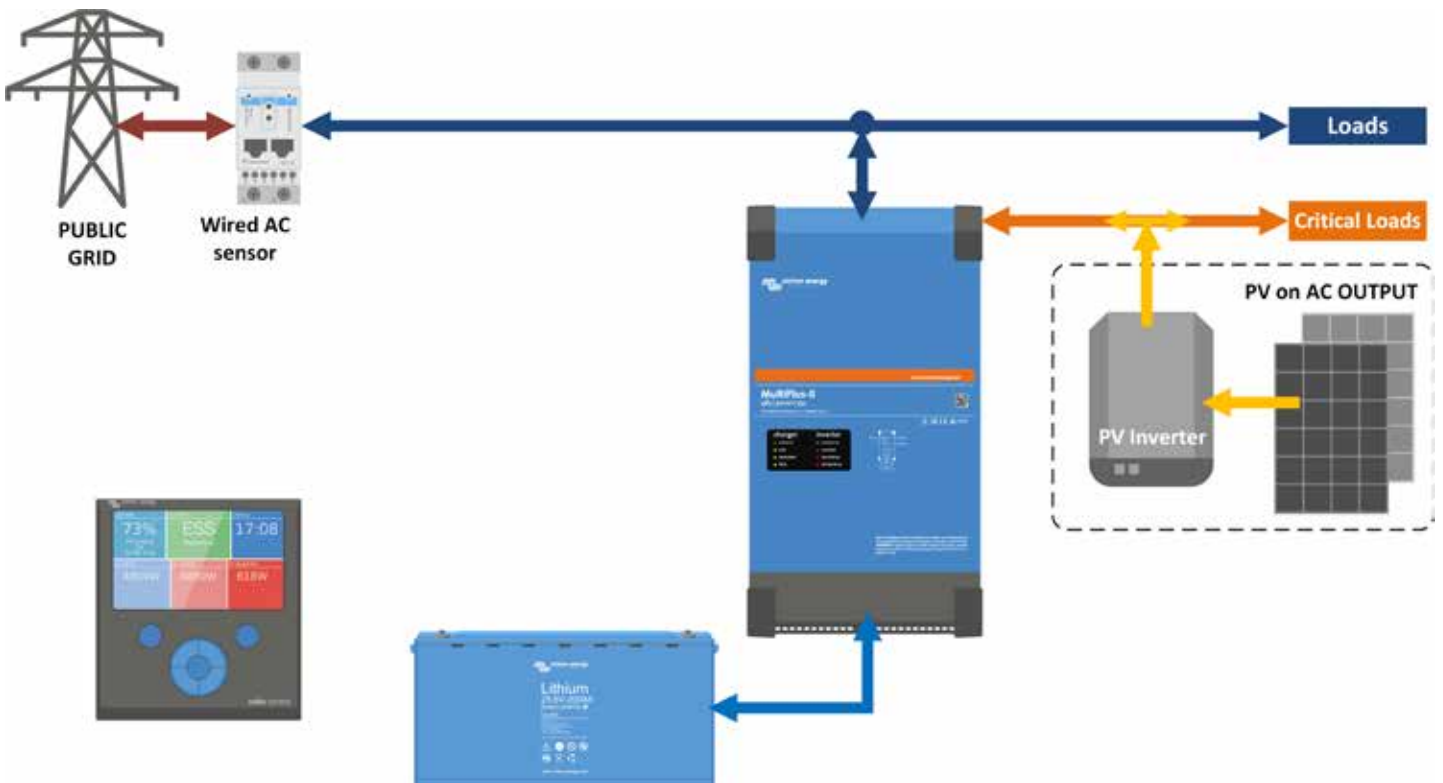

Option 3: DC-Coupled PV

The size of the PV array and the PV inverter is not limited by the maximum nominal power of the inverter/charger.

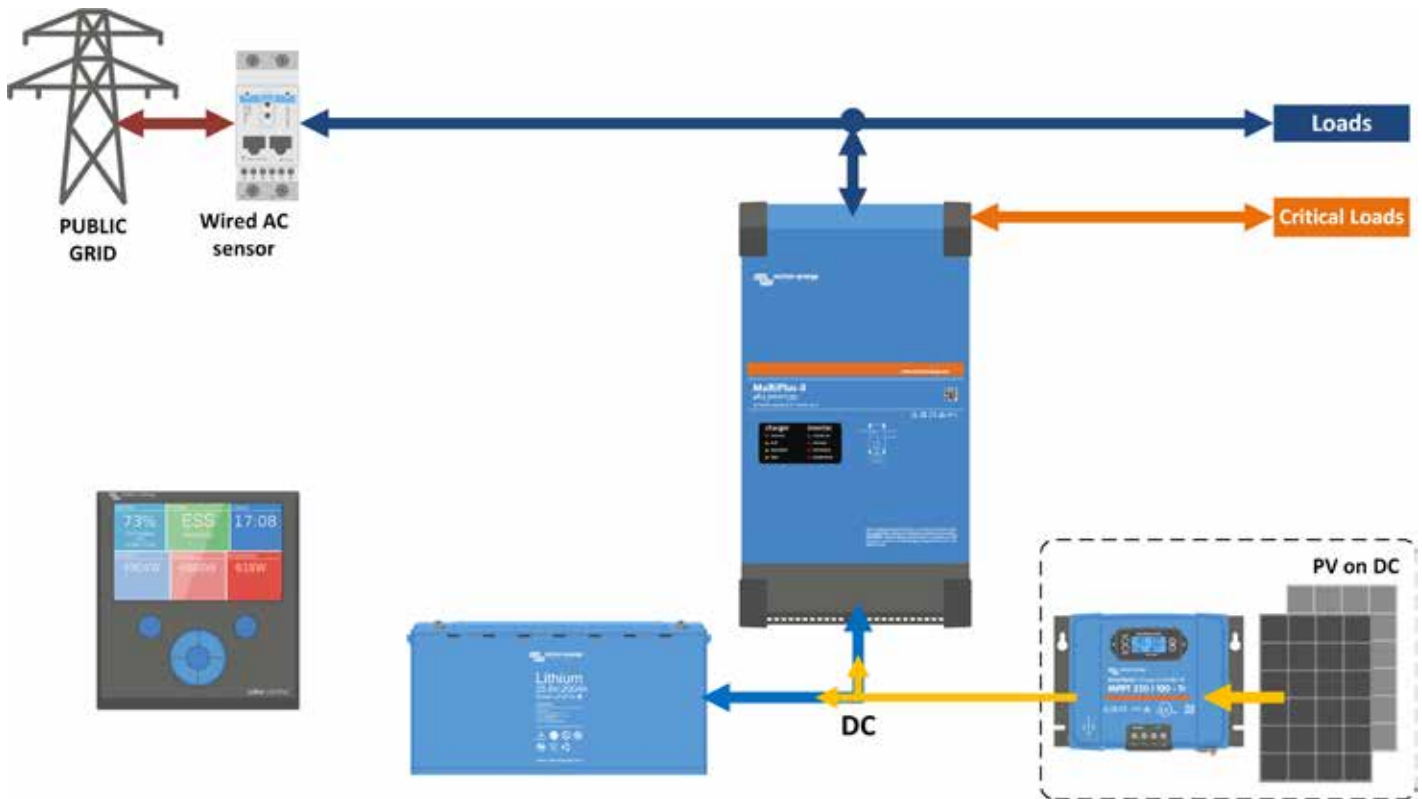

All options combined

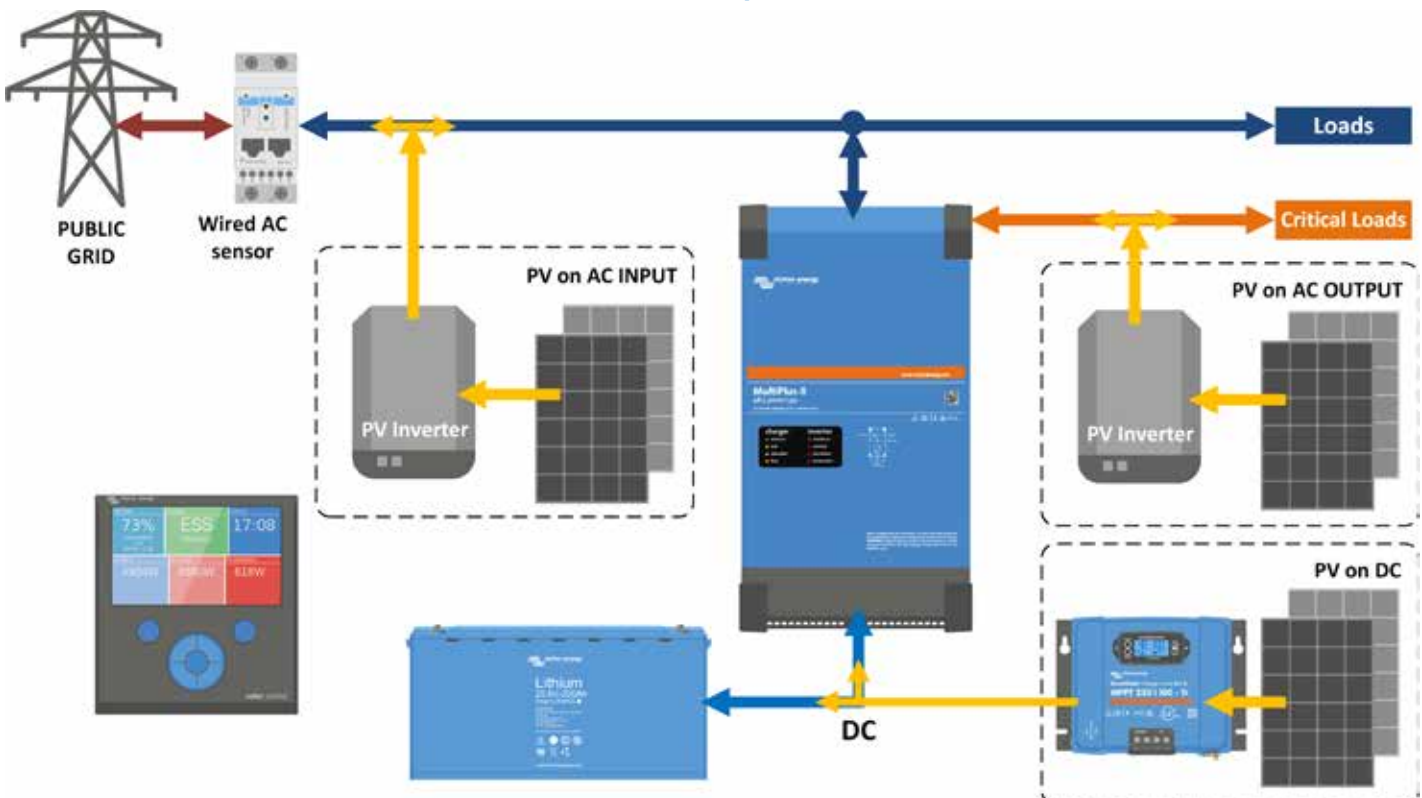

Monitoring

The major considerations for installing a self-consumption system are often financially and/or morally driven. For both, the goal is to minimise the import of grid energy and to optimise the consumption of self-generated power.

Modern inverter and battery monitoring technology helps to achieve this, by detecting how much energy to store and how and when to best use it. Besides this there is another important factor to consider.

This factor is the energy behaviour of the end-user themselves. This can differ between households and it is heavily dependent on circumstances, which can change from day to day. This makes coding the software, to precisely achieve optimal use of energy, quite a challenge.

If for example the washing machine is required on a particular day, the ideal day would be a sunny one just after the battery is (almost) full. Having said that direct power usage is preferable, which saves having to export energy to the grid or use battery power momentarily.

In order to be able to make these kinds of energy use decisions, monitoring is crucial to fine tune and optimise energy use based on ever changing circumstances. This makes monitoring systems an essential feature for every self-consumption system. Tests have shown that users of self-consumption systems with monitoring score a much higher level of self-consumption than those systems which lack it.

VRM app

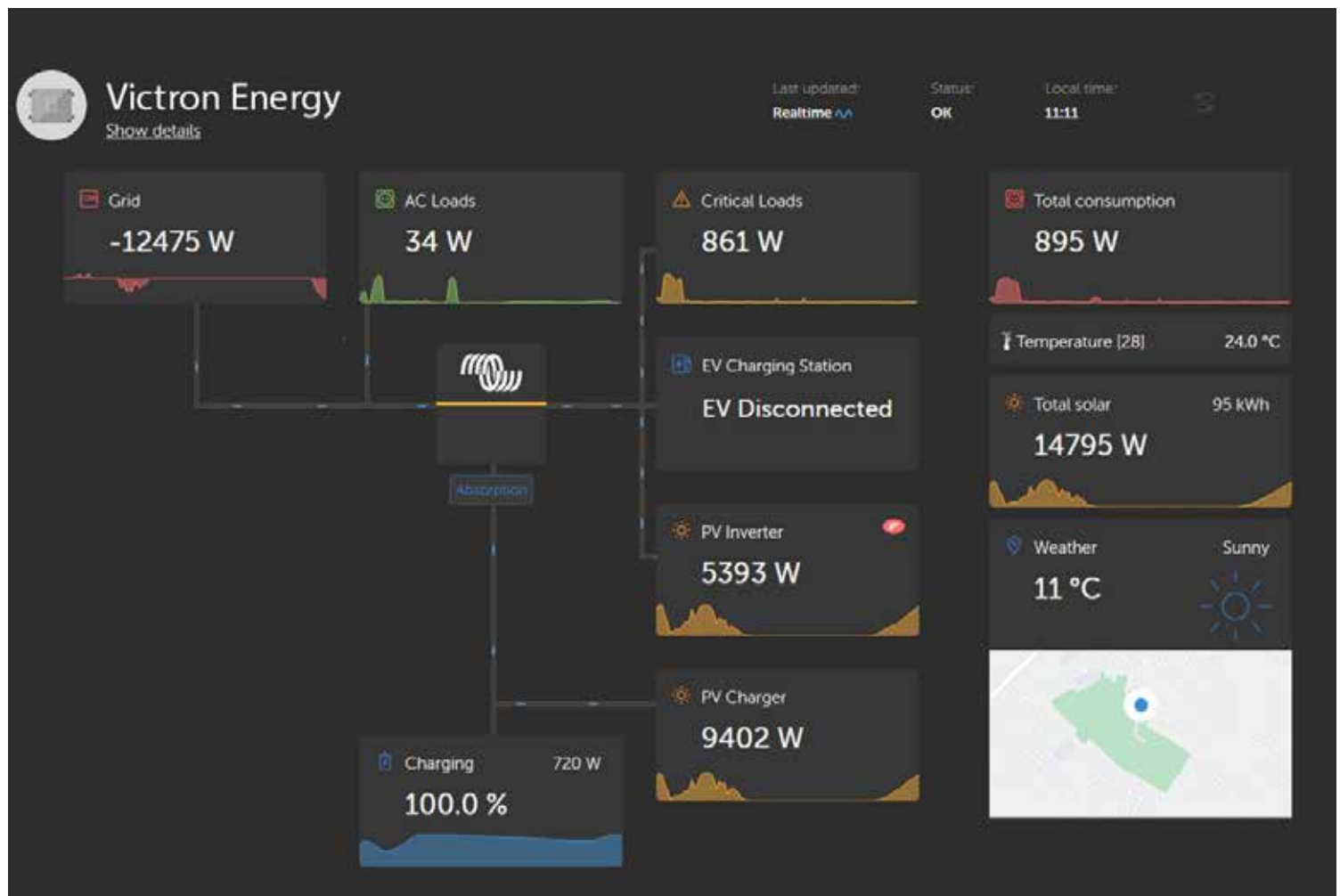

VRM: Live feed overview



Color Control GX



Cerbo GX



GX Touch

Victron Energy self-consumption systems can offer the best of both worlds

By using a Color Control GX, with its easy to use display, a clear system overview will show all the details needed to make crucial decisions as to which loads to use or to delay. Behind the overview screens other advanced information can be found - enough to satisfy even the most data-hungry users.

Cerbo GX

This all-new communication-centre allows you to always have perfect control over your system from wherever you are and maximises its performance. Simply connect through our Victron Remote Management (VRM) portal, or access directly, using the separate GX Touch, a MFD or our VictronConnect App thanks to its added Bluetooth capability.

GX Touch

The GX Touch 50 and GX Touch 70 are display accessories for our Cerbo GX. The five inch and seven inch touch screen displays give an instant overview of your system and allow to adjust settings in the blink of an eye.

VRM Online Portal

All this data is automatically sent to our free remote monitoring website: the VRM Online Portal, which allows even more options. It provides data analysis via the free VRM app which can be used on virtually every smartphone, so even when away from the Color Control GX the system can be easily monitored. Also the webserver is able to provide an advanced system overview, such as calculations of total solar yield, power generation and graphs - for all the equipment connected to the system.

To get an impression of the VRM Online Portal, please visit: <https://vrn.victronenergy.com>

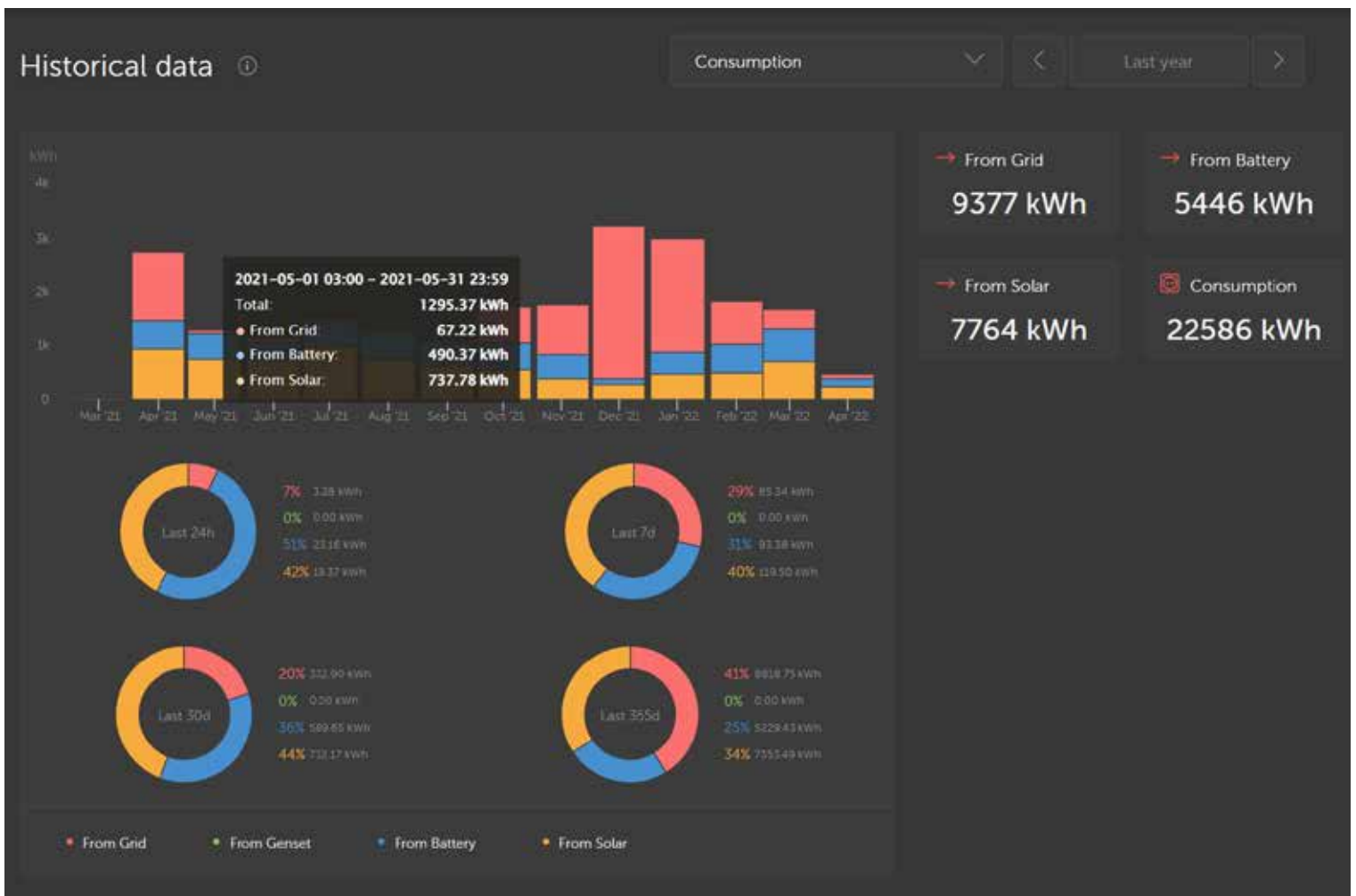

VRM: Historical data overview

Tools

There are a lot of tools available that make it easy to work with Victron Energy products, for both Victron installers as Victron distributors. Whether you would like to configure and read out your Victron products with VictronConnect using your smartphone, tablet or computer or you want to show or share your VRM site.

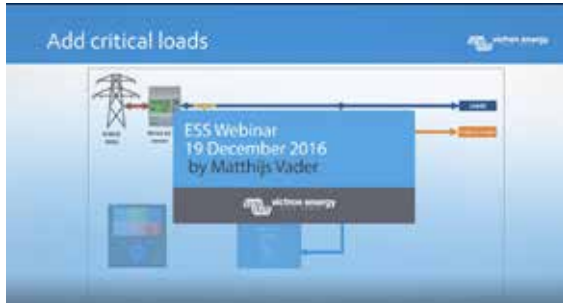

Instruction videos on Victron YouTube channel

On our YouTube channel you can watch Victron Energy instruction videos.

<https://www.youtube.com/user/VictronEnergyBV>

ESS Webinar

There is a webinar about ESS available on our youtube channel, in the languages English, Spanish, German and French.

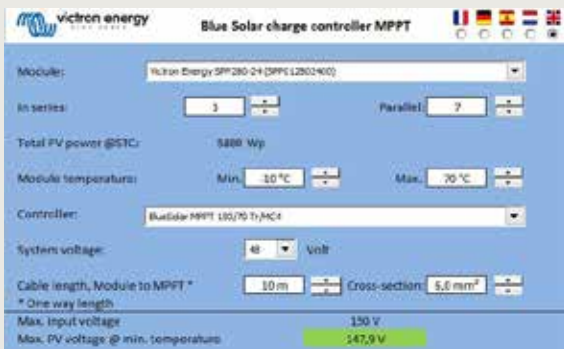

MPPT Calculator Excel sheet

With the MPPT Calculator Excel sheet you can match solar modules to MPPT charge controllers.

Download the Excel sheet from our software page:

<https://www.victronenergy.com/support-and-downloads/software>

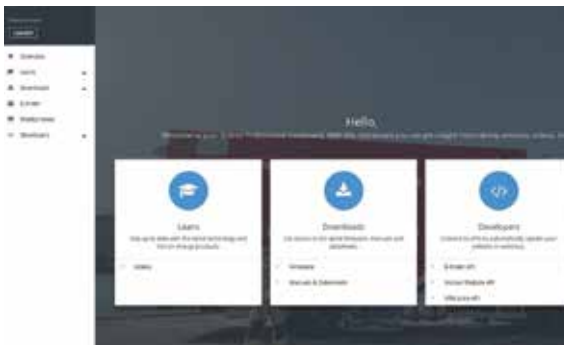

Victron Professional

With Victron Professional you can get insight into training sessions, videos, firmware files, APIs and the latest news. If you already use E-Order you can login with those credentials.

Sign up for Victron Professional here:

<https://professional.victronenergy.com>



VRM World: View shared VRM sites around the world

Ever wanted to show your clients, friends, colleagues how much solar energy your installation is generating or indeed any other data that you can see on your VRM site? Well now you can – using VRM World.

You need a VRM account to be able to view shared VRM sites. In your VRM portal it is possible to publicly share on VRM World.

Visit VRM World here:

<https://vrn.victronenergy.com/world/>

Our systems are comprised of various components. Some of which are specifically designed for specific markets. Other Victron components are applicable for a wide range of applications. You are able to find the specifications and other detailed information about these components in the 'Technical Information' section.



Battery Monitor

Key tasks of the Victron Battery Monitor are measuring charge and discharge currents as well as calculating the state-of-charge and time-to-go of a battery. An alarm is sent when certain limits are exceeded (such as an excessive discharge). It is also possible for the battery monitor to exchange data with the Victron Global Remote. This includes sending alarms.



Cerbo GX

This all-new communication-centre allows you to always have perfect control over your system from wherever you are and maximises its performance. Simply connect through our Victron Remote Management (VRM) portal, or access directly, using the separate GX Touch, a MFD or our VictronConnect app thanks to its added Bluetooth capability. This latest addition to the GX-range combines all the best of connectivity, redefining smart power solutions in every way.

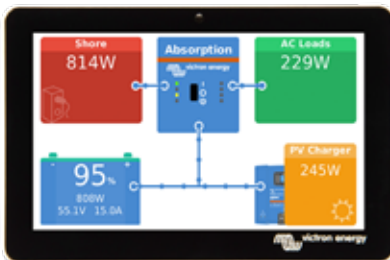

GX Touch 50 and GX Touch 70

The GX Touch 50 and GX Touch 70 are display accessories for our Cerbo GX. The five inch and seven inch touch screen displays give an instant overview of your system and allow to adjust settings in the blink of an eye. Simply connected to the Cerbo GX with one cable, Their super slim waterproof design, top-mountable setup and simple installation bring a lot of flexibility when creating a crisp and clean dashboard.



Current Transformer for MultiPlus-II

Current Transformer 100A:50mA for MultiPlus-II / MultiGrid-II to implement PowerControl and PowerAssist and to optimize self-consumption with external current sensing.



MPPT Control

The MPPT Control lets you see the status as well as setup all BlueSolar and SmartSolar MPPT Charge Controllers that have a VE.Direct communications port. The new MPPT Control is mounted in the familiar BMV-700 series housing, maintaining a consistent and professional look to your panels and systems monitoring equipment.



Energy Meter

The ET112 (for single phase max. 100A) and the ET340 (for three phase max. 65A) Energy Meters are typically used in an Energy Storage System. To measure the power and energy of the whole application at the distribution box. Or to measure the output of a PV Inverter, to display the data on the Color Control GX and the VRM Portal.



AC Current sensor - single phase - max 40A

The AC Current sensor is a simple external current sensor used to measure AC Current, Power (VA) and calculate energy of a PV Inverter connected to the AC input or output of a Multi or Quattro. These values can then be displayed and sent to the VRM-website by the Color Control. The two measurement wires can be connected to the AUX and/or temperature sense input of a Multi or Quattro.



Zigbee to USB converter & Zigbee to RS485

This pair of Zigbee converters is to wirelessly connect an Energy Meter to a GX Device.

Zigbee to USB converter, DRF2658C, DTK
 Zigbee to RS485 converter, DRF2659C, DTK



Ziehl Voltage and frequency relay UFR1001E

The UFR1001E monitors voltage and frequency in plants for own generation of electricity. It fulfills the requirements of VDE-AR-N 4105 bdeu-directive, G59/3, G83/2 and ÖVE/ÖNORM E 8001-4-712:2009 for generators connected to the public grid.

For more information, we refer you to the datasheet and certificates below which are available to download. Or visit www.ziehl.de and look for the UFR1001E under the Mains monitoring group.



Ziehl Voltage and Frequency Relay SPI1021

Voltage- and Frequency-Relay with integrated Vector-Shift-Relay Grid- and Plant Protection.

For more information, we refer you to the datasheet and certificates below which are available to download. Or visit www.ziehl.de and look for the SPI1021 under the Mains monitoring group.



Anti-Islanding Box 63A single and three phase

The Anti-Islanding Box 63A single and three phase is a combination of an anti-islanding device, the Ziehl UFR1001E, two in-line contactors and main circuit breaker. It is suitable for both single phase or 3 phase systems. It is rated up to 63A per phase and all parts are conveniently housed in an IP65 rated enclosure.

The Anti-Islanding Box can be added to a grid-feeding inverter/charger system (ESS) to meet local anti-islanding regulations.



Note - for our newest datasheets please refer to our website:
www.victronenergy.com

TECHNICAL INFORMATION

EasySolar 12V and 24V, 1600VA	20
EasySolar-II 3kVA MPPT 250/70 GX, 5kVA MPPT 250/100 GX	22
MultiPlus inverter/charger 500VA - 2kVA 230V	24
MultiPlus inverter/charger 800VA - 5kVA 230V	26
Quattro inverter/charger 3kVA - 15kVA 230V	28
MultiPlus-II inverter/charger 3kVA - 10kVA 230V	30
MultiPlus-II inverter/charger 3kVA & 5kVA 230V GX	32
MultiPlus inverter/charger 2kVA and 3kVA 120V	34
MultiPlus-II inverter/charger 3kVA 2x120V	36
Quattro inverter/charger 3kVA - 10kVA 120V	38
Cerbo GX & GX Touch	40
Color Control GX	42
BMV-712 Smart: Bluetooth inside	46
SmartShunt 500A / 1000A / 2000A	48
SmartShunt IP65 500A / 1000A / 2000A	50
BlueSolar and SmartSolar MPPT Charge Controllers - Overview	52
SmartSolar charge controller MPPT 75/10, 75/15, 100/15 & 100/20-48V	53
SmartSolar charge controller MPPT 100/30 & 100/50	54
SmartSolar charge controller MPPT 150/35 & 150/45	55
SmartSolar charge controller MPPT 150/45 - MPPT 150/70	56
SmartSolar charge controller MPPT 150/70 up to 150/100 VE.Can	57
SmartSolar charge controller MPPT 250/60 & 250/70	58
SmartSolar charge controller MPPT 250/70 up to 250/100 VE.Can	59
SmartSolar MPPT RS 450/100 & 450/200	60



All-in-one solar power solution

The EasySolar combines a MPPT solar charge controller, an inverter/charger and AC distribution in one enclosure.

The product is easy to install, with a minimum of wiring.

The solar charge controller: Blue Solar MPPT 100/50

Up to three strings of PV panels can be connected to three sets of MC4 (PV-ST01) PV connectors.

The inverter/charger: MultiPlus Compact 12/1600/70 or 24/1600/40

The MPPT charge controller and the MultiPlus Compact inverter/charger share the DC battery cables (included). The batteries can be charged with solar power (SmartSolar MPPT) and/or with AC power (inverter/charger) from the utility grid or a genset.

AC distribution

The AC distribution consists of a RCD (30 mA/16 A) and four AC outputs protected by two 10A and two 16A circuit breakers.

One 16A output is controlled by the AC input: it will switch on only when AC is available.

PowerAssist

Unique PowerAssist technology protects the utility or generator supply from being overloaded by adding extra inverter power when needed.

Unique solar application software

Several software programs (Assistants) are available to configure the system for various grid interactive or stand-alone applications. Please see

<http://www.victronenergy.nl/support-and-downloads/software/>

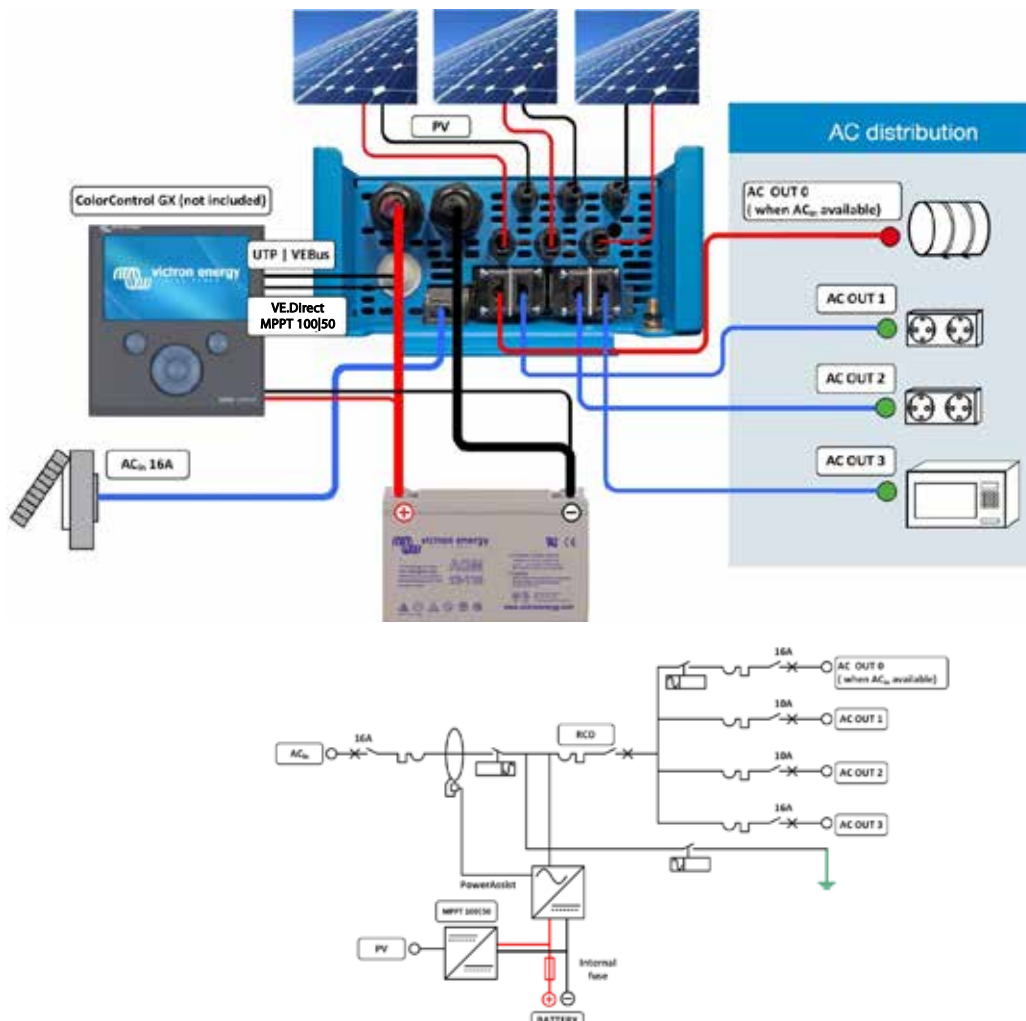

EasySolar	EasySolar 12/1600/70	EasySolar 24/1600/40
Inverter/charger		
Transfer switch	16A	
INVERTER		
Input voltage range	9,5 – 17V	19 – 33V
'Heavy duty' output AC 0	16A	
Output AC1, 2, 3	Output voltage: 230 VAC ± 2% Frequency: 50 Hz ± 0,1% (1)	
Cont. output power at 25°C (3)	1600VA / 1300W	
Cont. output power at 40°C	1200W	
Peak power	3000W	
Maximum efficiency	92%	94%
Zero load power	8W	10W
Zero load power in search mode	2W	3W
CHARGER		
AC Input	Input voltage range: 187-265VAC Input frequency: 45 – 65Hz Power factor: 1	
Charge voltage 'absorption'	14,4V	28,8V
Charge voltage 'float'	13,8V	27,6V
Storage mode	13,2V	26,4V
Charge current house battery (4)	70A	40A
Charge current starter battery (A)	4	
Battery temperature sensor	Yes	
Programmable relay (5)	Yes	
Protection (2)	a – g	
Solar Charge Controller		
Model	MPPT 100/50	
Maximum output current	50A	
Maximum PV power, 6a,b)	700W	1400W
Maximum PV open circuit voltage	100V	100V
Maximum efficiency	98%	
Self-consumption	10 mA	
Charge voltage 'absorption', default setting	14,4V	28,8V
Charge voltage 'float', default setting	13,8V	27,6V
Charge algorithm	multi-stage adaptive	
Temperature compensation	-16mV/°C	-32mV/°C
Protection	a - g	
COMMON CHARACTERISTICS		
Operating temp. range	-20 to +50°C (fan assisted cooling)	
Humidity (non-condensing):	max 95%	
ENCLOSURE		
Material & Colour	aluminium (blue RAL 5012)	
Protection category	IP 21	
Battery-connection	Battery cables of 1.5 meter	
PV connection	Three sets of MC4 (PV-ST01) PV connectors.	
230 V AC-connection	G-ST18i connector	
Weight	15kg	
Dimensions (hxxwxd)	745 x 214 x 110mm	
STANDARDS		
Safety	EN 60335-1, EN 60335-2-29, EN 62109	
Emission / Immunity	EN 55014-1, EN 55014-2, EN 61000-3-3	
Automotive Directive	2004/104/EC	
1) Can be adjusted to 60Hz and to 240V 2) Protection a. Output short circuit b. Overload c. Battery voltage too high d. Battery voltage too low e. Temperature too high f. 230 VAC on inverter output g. Input voltage ripple too high	3) Non-linear load, crest factor 3:1 4) At 25°C ambient 5) Programmable relay which can be set for general alarm, DC under voltage or genset start signal function 6a) If more PV power is connected, the controller will limit input power to 700W resp. 1400W 6b) PV voltage must exceed Vbat + 5V for the controller to start. Thereafter minimum PV voltage is Vbat + 1V	

EasySolar-II GX 3 kVA

VRM app for Wi-Fi

Monitor and manage your Victron Energy system from your smart phone and tablet. Available for both iOS and Android.

VRM Portal

Our free remote monitoring website (VRM) will display all your system data in a comprehensive graphical format. System settings can be changed remotely via the portal. Alarms can be received by e-mail.

The all-in-one solar power solution

The Victron EasySolar-II GX integrates the following elements:

- A MultiPlus-II inverter/charger
- A SmartSolar MPPT-Tr solar charge controller
- A GX device with a 2 x 16-character display.

These elements come prewired together inside a single unit. This greatly simplifies most installations, saving time and money.

Display and Wi-Fi

The display reads battery, inverter and solar charge controller parameters.

The same parameters can be accessed with a smartphone or other Wi-Fi enabled device.

In addition, Wi-Fi can be used to set up the system and to change settings.

Solar charge controller

The DC output of the SmartSolar MPPT is parallel wired with the DC connection of the MultiPlus-II inverter/charger.

The on/off mechanism of the MultiPlus-II also controls the SmartSolar MPPT.

GX device

The integrated GX device includes:

- A BMS-Can interface. This can be used to connect to a compatible CAN-bus managed battery. Note that this not a VE.Can compatible port.
- A USB port
- An Ethernet port
- A VE.Direct port

The GX device controls the MultiPlus-II and the SmartSolar MPPT with respectively a VE.Bus and a VE.Direct connection.

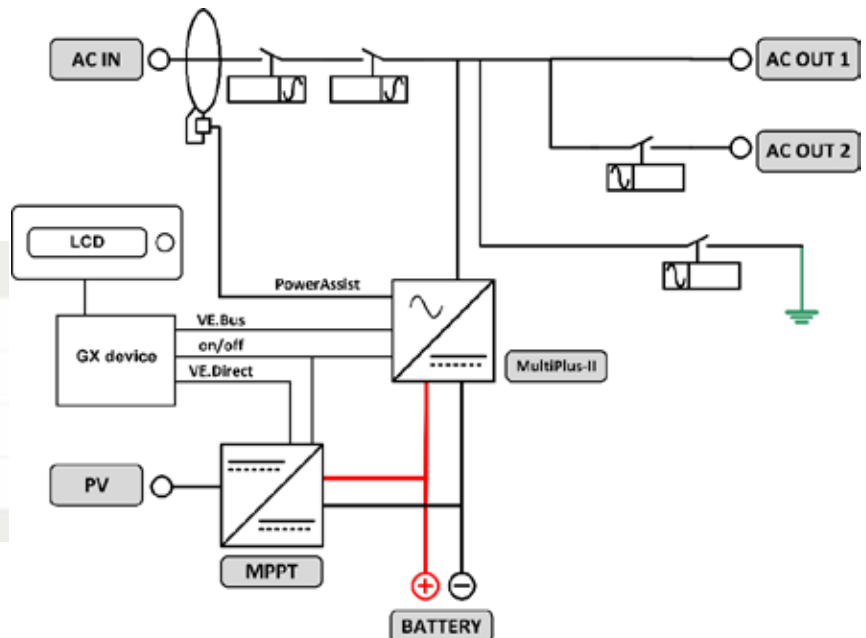

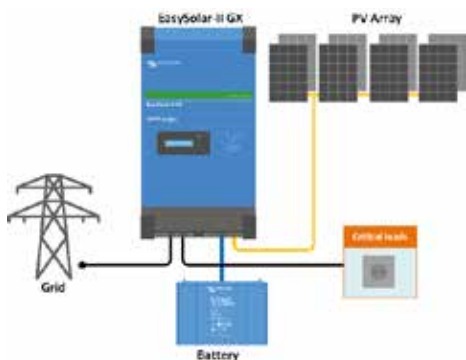

Grid in-line topology

The EasySolar-II GX will use excess PV power to charge the batteries or to feed power back into the grid and will discharge the battery or use power from the grid to supplement a shortage of PV power. In case of a power outage, the EasySolar-II GX will disconnect the grid and continue to supply the loads.

Loads that should shut down when AC input power is not available can be connected to a second output (not shown). These loads will be taken into account by the PowerControl and PowerAssist function in order to limit AC input current to a safe value.

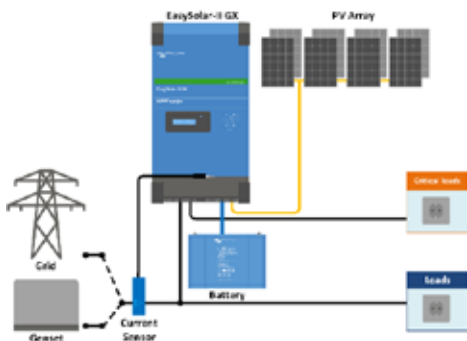

Grid parallel topology

The EasySolar-II GX will use data from the external AC current sensor (must be ordered separately) or power meter to optimise self-consumption and, if required, to prevent grid feed. In case of a power outage, the EasySolar-II GX will continue to supply the critical loads



Current sensor 100A:50mA

To implement PowerControl and PowerAssist and to optimise self-consumption with external current sensing.

Maximum current: 50 A resp. 100 A.
Length of connection cable: 1 m.



Connection area

EasySolar-II	24/3000/70-32 MPPT 250/70 GX	48/3000/35-32 MPPT 250/70 GX	48/5000/70-50 MPPT 250/100 GX
INVERTER/CHARGER			
PowerControl & PowerAssist	Yes		
Transfer switch	32 A	50 A	
Maximum AC input current	32 A	50 A	
Auxiliary output	32 A	50 A	
INVERTER			
Input voltage range	19 – 33 V	38 – 66 V	38 – 66 V
Output	Output voltage: 230 VAC ± 2 % Frequency: 50 Hz ± 0,1 % (1)		
Cont. output power at 25 °C (3)	3000 VA / 2400 W	3000 VA / 2400 W	5000 VA / 4000 W
Cont. output power at 40 °C / 55 °C	2200 W / 1700 W	2200 W / 1700 W	3700 W / 3000 W
Maximum apparent feed-in power	2470W / 3000 VA	2470W / 3000 VA	4400 W / 5000 VA
Peak power	5500 W	5500 W	9000 W
Maximum efficiency	94 %	95 %	96%
Zero load power	13 W	11 W	18 W
Zero load power in AES mode	9 W	7 W	12 W
Zero load power in Search mode	3 W	2 W	2 W
CHARGER			
AC Input	Input voltage range: 187-265 VAC Input frequency: 45 – 65 Hz		
Charge voltage 'absorption'	28.8 V	57,6 V	
Charge voltage 'float'	27.6 V	55,2 V	
Storage mode	26.4 V	52,8 V	
Maximum battery charge current	70 A	35 A	70 A
Battery temperature sensor	Yes		
Programmable relay (5)	Yes		
Protection (2)	a - g		
VE.Bus communication port	For parallel and three phase operation, remote monitoring and system integration		
General purpose com. port	Yes, 2x		
SMARTSOLAR CHARGE CONTROLLER			
Model	MPPT 250/70-Tr		MPPT 250/100-Tr
Maximum output current	70 A		100 A
Maximum PV power	2000 W	4000 W	5800 W
Maximum PV open circuit voltage	250 V		
Maximum efficiency	99%		
Self-consumption	20 mA		
Charge voltage 'absorption', default	57,6 V		
Charge voltage 'float', default	55,2 V		
Protection (2)	a – e		
GENERAL			
Interfaces	BMS-Can, USB, Ethernet, VE.Direct, Wi-Fi		
Remote on-off	Yes		
Operating temp. range	-20 to +45 °C (fan assisted cooling) Max. altitude 2000 m		
Humidity (non-condensing):	max 95 %		
ENCLOSURE			
Material & Colour	aluminium (blue RAL 5012)		
Protection category	IP21		
Battery-connection	M8 bolts		
PV connection	M6 bolts		
230 VAC-connection	Screw terminals 16 mm ² (6 AWG)		
Weight	26 kg	26 kg	38.6 kg
Dimensions (h x w x d) mm	499 x 268 x 237		604 x 323 x 253
STANDARDS			
Safety	EN-IEC 60335-1, EN-IEC 60335-2-29, EN-IEC 62109-1, EN-IEC 62109-2		
Emission / Immunity	EN 55014-1, EN 55014-2, EN-IEC 61000-3-2, EN-IEC 61000-3-3 IEC 61000-6-1, IEC 61000-6-2, IEC 61000-6-3		
Anti-islanding	See our website		
1) Can be adjusted to 60 Hz 2) Protection key: a) output short circuit b) overload c) battery voltage too high d) battery voltage too low e) temperature too high f) 230 VAC on inverter output g) input voltage ripple too high	3) Non-linear load, crest factor 3:1 4) At 25 °C ambient 5) Programmable relay which can be set for general alarm, DC under voltage or genset start/stop function. AC rating: 230 V / 4 A, DC rating: 4 A up to 35 VDC and 1 A up to 60 VDC		

MultiPlus inverter/charger 500VA - 2kVA 230V



MultiPlus
500 / 800 / 1200 / 1600 VA



MultiPlus 2000 VA
(bottom cover removed)

Multifunctional, with intelligent power management

The MultiPlus is a powerful true sine wave inverter, a sophisticated battery charger that features adaptive charge technology, and a high-speed AC transfer switch in a single compact enclosure. Next to these primary functions, the MultiPlus has several advanced features, as outlined below.

Parallel operation and three phase capability

Up to six Multis can operate in parallel to achieve higher power output. In addition to parallel connection, three units can be configured for three-phase output.

PowerControl - Dealing with limited generator, shore side or grid power

With the Multi Control Panel a maximum generator or shore current can be set. The MultiPlus will then take account of other AC loads and use whatever is extra for charging, thus preventing the generator or shore supply from being overloaded.

PowerAssist - Boosting the capacity of shore or generator power

This feature takes the principle of PowerControl to a further dimension. It allows the MultiPlus to supplement the capacity of the alternative source. Where peak power is so often required only for a limited period, the MultiPlus will make sure that insufficient shore or generator power is immediately compensated for by power from the battery. When the load reduces, the spare power is used to recharge the battery.

Four stage adaptive charger and dual bank battery charging

The main output provides a powerful charge to the battery system by means of advanced 'adaptive charge' software. The software fine-tunes the three-stage automatic process to suit the condition of the battery, and adds a fourth stage for long periods of float charging. The adaptive charge process is described in more detail on the Phoenix Charger datasheet and on our website, under Technical Information. In addition to this, the MultiPlus will charge a second battery using an independent trickle charge output intended for a main engine or generator starter battery.

High start-up power

Needed to start high inrush loads such as power converters for LED lamps, halogen lamps or electric tools.

Search Mode

When Search Mode is 'on', the power consumption of the inverter in no-load operation is decreased by approx. 70%. In this mode the Multi, when operating in inverter mode, is switched off in case of no load or very low load, and switches on every two seconds for a short period. If the output current exceeds a set level, the inverter will continue to operate. If not, the inverter will shut down again.

Programmable relay

By default, the programmable relay is set as an alarm relay, i.e. the relay will de-energise in the event of an alarm or a pre-alarm (inverter almost too hot, ripple on the input almost too high, battery voltage almost too low).

Remote on / off / charger on

Three pole connector.

On-site system configuring, monitoring and control

After installation, the MultiPlus is ready to go.

Some settings can be changed with DIP switches.

500/800/1200VA models: remote switch / battery charge voltage / inverter frequency / search mode.

1600/2000VA models: battery charge voltage / search mode.

For more settings use VE-Config or the VE.Bus Smart dongle.

Remote configuring and monitoring

Install a Cerbo GX or other GX product to connect to the internet.

Operational data can be stored and displayed on our VRM (Victron Remote Management) website, free of charge.

When connected to the internet, systems can be accessed remotely, and settings can be changed.



GX Touch and Cerbo GX

Provides intuitive system control and monitoring.

Besides system monitoring and control the Cerbo GX enables access to our free remote monitoring website: the VRM Online Portal.



VRM Portal

Our free remote monitoring website (VRM) will display all your system data in a comprehensive graphical format. System settings can be changed remotely via the portal. Alarms can be received by e-mail.

12 Volt 24 Volt 48 Volt	MultiPlus 12/500/20 MultiPlus 24/500/10 MultiPlus 48/500/6	MultiPlus 12/800/35 MultiPlus 24/800/16 MultiPlus 48/800/9	MultiPlus 12/1200/50 MultiPlus 24/1200/25 MultiPlus 48/1200/13	MultiPlus 12/1600/70 MultiPlus 24/1600/40 MultiPlus 48/1600/20	MultiPlus 12/2000/80 MultiPlus 24/2000/50 MultiPlus 48/2000/25
PowerControl / PowerAssist	No	Yes	Yes	Yes	Yes
Three Phase and parallel operation	Yes	Yes	Yes	Yes	Yes
Transfer switch	16 A	16 A	16 A	16 A	35 A
INVERTER					
Input voltage range	9,5 – 17 V		19 – 33 V	38– 66 V	
Output	Output voltage: 230VAC ± 2%		Frequency: 50Hz ± 0,1% (1)		
Cont. output power at 25°C (3)	500 VA	800 VA	1200 VA	1600 VA	2000 VA
Cont. output power at 25°C	430 W	700 W	1000 W	1300 W	1600 W
Cont. output power at 40°C	400 W	650 W	900 W	1100 W	1400 W
Cont. output power at 65°C	300 W	400 W	600 W	800 W	1000 W
Peak power	900 W	1600 W	2400 W	2800 W	3500 W
Maximum efficiency	90 / 91 / 92%	92 / 93 / 94%	93 / 94 / 95%	93 / 94 / 95%	93 / 94 / 95%
Zero-load power	6 / 6 / 7 W	7 / 7 / 8 W	10 / 9 / 10 W	10 / 9 / 10 W	10 / 9 / 10 W
Zero-load power in search mode	2 / 2 / 3 W	2 / 2 / 3 W	3 / 3 / 3 W	3 / 3 / 3 W	3 / 3 / 3 W
CHARGER					
AC Input	Input voltage range: 187-265 VAC		Input frequency: 45 – 65 Hz		
Charge voltage 'absorption'	14,4 / 28,8 / 57,6 V				
Charge voltage 'float'	13,8 / 27,6 / 55,2 V				
Storage mode	13,2 / 26,4 / 52,8 V				
Charge current house battery (4)	20 / 10 / 6 A	35 / 16 / 9 A	50 / 25 / 13 A	70 / 40 / 20 A	80 / 50 / 25 A
Charge current starter battery	1A (12 V and 24 V models only)				
Battery temperature sensor	Yes				
GENERAL					
Programmable relay (5)	Yes				
Protection (2)	a – g				
VE.Bus communication port	For parallel and three phase operation, remote monitoring and system integration (RJ45-splitter ASS030065510 needed for 500 / 800 / 1200 VA models)				
Remote on-off	On/off/charger only			On/off	
DIP switches	Yes (6)	Yes (6)	Yes (6)	Yes (7)	Yes (7)
Internal DC fuse	125 / 60 / 30 A	150 / 80 / 40 A	200 / 100 / 50 A	200 / 125 / 60 A	no
Common Characteristics	Operating temp. range: -40 to +65°C (fan assisted cooling)			Humidity (non-condensing): max 95%	
ENCLOSURE					
Common Characteristics	Material & Colour: Steel/ABS (blue RAL 5012)		Protection category: IP 21		Steel (RAL 5012), IP22
Battery-connection	16 / 10 / 10 mm ²	25 / 16 / 10 mm ²	35 / 25 / 10 mm ²	50 / 35 / 16 mm ²	M8 bolts
230V AC-connection	G-ST18i connector				Screw
Weight	4,4 kg	6,4 kg	8,2 kg	10,2 kg	15,5 kg
Dimensions (h x w x d)	311 x 182 x 100 mm	360 x 240 x 100 mm	406 x 250 x 100 mm	470 x 265 x 120 mm	506 x 236 x 147 mm
STANDARDS					
Safety	EN-IEC 60335-1, EN-IEC 60335-2-29, EN 62109-1				
Emission Immunity	EN 55014-1, EN 55014-2, EN-IEC 61000-3-2, EN-IEC 61000-3-3, IEC 61000-6-1, IEC 61000-6-2, IEC 61000-6-3				
Automotive Directive	ECE R10-5				
1) Can be adjusted to 60Hz and to 240V 2) Protection: a. Output short circuit b. Overload c. Battery voltage too high d. Battery voltage too low e. Temperature too high f. 230VAC on inverter output g. Input voltage ripple too high	3) Non-linear load, crest factor 3:1 4) Up to 25°C ambient 5) Programmable relay which can be set for: general alarm, DC under voltage or generator start/stop signal function AC rating: 230V/4A DC rating: 4A up to 35VDC, 1A up to 60VDC 6) Remote / battery charge voltage / inverter frequency / search mode 7) Battery charge voltage / search mode				



Digital Multi Control Panel

A convenient and low cost solution for remote monitoring, with a rotary knob to set PowerControl and PowerAssist levels.



VE.Bus Smart Dongle

Measures battery voltage and temperature and allows monitoring and control of Multis and Quattros with a smartphone or other Bluetooth enabled device.



VRM app

Monitor and manage your Victron Energy system from your smart phone and tablet. Available for both iOS and Android



MK3-USB (VE.Bus to USB interface)

Connects to a USB port (see 'A guide to VEConfigure')



BMV-712 Smart Battery Monitor

Use a smartphone or other Bluetooth enabled device to:

1. customize settings,
2. monitor all important data on single screen,
3. view historical data,
4. update the software when new features become available.

**MultiPlus
24/3000/70**

Two AC Outputs

The main output has no break functionality. The MultiPlus takes over the supply to the connected loads in the event of a grid failure or when shore/generator power is disconnected. This happens so fast (less than 20 milliseconds) that computers and other electronic equipment will continue to operate without disruption.

The second output is live only when AC is available on the input of the MultiPlus. Loads that should not discharge the battery, like a water heater for example can be connected to this output (second output available on models rated at 3 kVA and more).

Virtually unlimited power thanks to parallel operation

Up to 6 Multis can operate in parallel to achieve higher power output. Six 24/5000/120 units, for example, will provide 25 kW / 30 kVA output power with 720 Amps charging capacity.

Three phase capability

In addition to parallel connection, three units of the same model can be configured for three phase output. But that's not all: up to 6 sets of three units can be parallel connected for a 75 kW / 90 kVA inverter and more than 2000 Amps charging capacity.

PowerControl - Dealing with limited generator, shore side or grid power

The MultiPlus is a very powerful battery charger. It will therefore draw a lot of current from the generator or shore side supply (nearly 10 A per 5 kVA Multi at 230 VAC). With the Multi Control Panel a maximum generator or shore current can be set. The MultiPlus will then take account of other AC loads and use whatever is extra for charging, thus preventing the generator or shore supply from being overloaded.

PowerAssist - Boosting the capacity of shore or generator power

This feature takes the principle of PowerControl to a further dimension. It allows the MultiPlus to supplement the capacity of the alternative source. Where peak power is so often required only for a limited period, the MultiPlus will make sure that insufficient shore or generator power is immediately compensated for by power from the battery. When the load reduces, the spare power is used to recharge the battery.

Solar energy: AC power available even during a grid failure

The MultiPlus can be used in off grid as well as grid connected PV and other alternative energy systems. Loss of mains detection software is available.

System configuring

- In case of a stand-alone application, if settings have to be changed, this can be done in a matter of minutes with a DIP switch setting procedure.
- Parallel and three phase applications can be configured with VE.Bus Quick Configure and VE.Bus System Configurator software.
- Off grid, grid interactive and self-consumption applications, involving grid-tie inverters and/or MPPT Solar Chargers can be configured with Assistants (dedicated software for specific applications).

On-site Monitoring and control

Several options are available: Battery Monitor, Multi Control Panel, Color Control GX or other GX devices, smartphone or tablet (Bluetooth Smart), laptop or computer (USB or RS232).

Remote Monitoring and control

Color Control GX or other GX devices.

Data can be stored and displayed on our VRM (Victron Remote Management) website, free of charge.

Remote configuring

When connected to the Ethernet, systems with a Color Control GX or other GX device can be accessed and settings can be changed remotely.

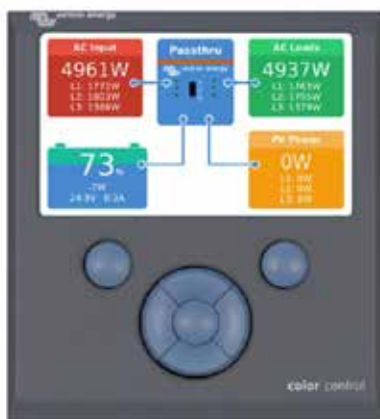
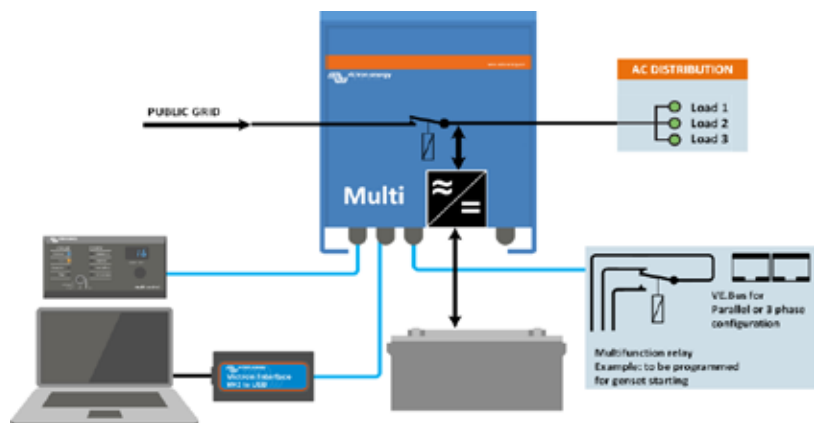
**MultiPlus Compact
12/2000/80**

**Color Control GX, showing a
PV application**

MultiPlus	12 Volt 24 Volt 48 Volt	C 12/800/35 C 24/ 800/16	C 12/1200/50 C 24/1200/25	C 12/1600/70 C 24/1600/40	C 12/2000/80 C 24/2000/50	12/3000/120 24/3000/70 48/3000/35	24/5000/120 48/5000/70
PowerControl		Yes	Yes	Yes	Yes	Yes	Yes
PowerAssist		Yes	Yes	Yes	Yes	Yes	Yes
Transfer switch (A)		16	16	16	30	16 or 50	100
INVERTER							
Input voltage range (V DC)		9,5 – 17 V		19 – 33 V	38 – 66 V		
Output		Output voltage: 230 VAC ± 2%			Frequency: 50 Hz ± 0,1% (1)		
Cont. output power at 25°C (VA) (3)		800	1200	1600	2000	3000	5000
Cont. output power at 25°C (W)		700	1000	1300	1600	2400	4000
Cont. output power at 40°C (W)		650	900	1200	1400	2200	3700
Cont. output power at 65°C (W)		400	600	800	1000	1700	3000
Peak power (W)		1600	2400	3000	4000	6000	10.000
Maximum efficiency (%)		92 / 94	93 / 94	93 / 94	93 / 94	93 / 94 / 95	94 / 95
Zero load power (W)		8 / 10	8 / 10	8 / 10	9 / 11	20 / 20 / 25	30 / 35
Zero load power in AES mode (W)		5 / 8	5 / 8	5 / 8	7 / 9	15 / 15 / 20	25 / 30
Zero load power in Search mode (W)		2 / 3	2 / 3	2 / 3	3 / 4	8 / 10 / 12	10 / 15
CHARGER							
AC Input		Input voltage range: 187-265 VAC		Input frequency: 45 – 65 Hz	Power factor: 1		
Charge voltage 'absorption' (V DC)		14,4 / 28,8 / 57,6					
Charge voltage 'float' (V DC)		13,8 / 27,6 / 55,2					
Storage mode (V DC)		13,2 / 26,4 / 52,8					
Charge current house battery (A) (4)		35 / 16	50 / 25	70 / 40	80 / 50	120 / 70 / 35	120 / 70
Charge current starter battery (A)		4 (12 V and 24 V models only)					
Battery temperature sensor		yes					
GENERAL							
Auxiliary output (5)		n. a.	n. a.	n. a.	n. a.	Yes (16A)	Yes (50A)
Programmable relay (6)		Yes					
Protection (2)		a - g					
VE.Bus communication port		For parallel and three phase operation, remote monitoring and system integration					
General purpose com. port		n. a.	n. a.	n. a.	n. a.	Yes	Yes
Remote on-off		Yes					
Common Characteristics		Operating temp. range: -40 to +65°C (fan assisted cooling) Humidity (non-condensing): max 95%					
ENCLOSURE							
Common Characteristics		Material & Colour: aluminium (blue RAL 5012)			Protection category: IP 21		
Battery-connection		battery cables of 1.5 meter		M8 bolts	Four M8 bolts (2 plus and 2 minus connections)		
230 V AC-connection		G-ST18i connector		Spring-clamp	Screw terminals 13 mm ² (6 AWG)	M6 bolts	
Weight (kg)		10	10	10	12	18	30
Dimensions (hwxwd in mm)		375 x 214 x 110		520 x 255 x 125	362 x 258 x 218	444 x 328 x 240	
STANDARDS							
Safety		EN-IEC 60335-1, EN-IEC 60335-2-29, IEC 62109-1					
Emission, Immunity		EN 55014-1, EN 55014-2, EN-IEC 61000-3-2, EN-IEC 61000-3-3, IEC 61000-6-1, IEC 61000-6-2, IEC 61000-6-3					
Road vehicles		12V and 24V models: ECE R10-4					
Anti-islanding		See our website					
1) Can be adjusted to 60 HZ. 120 V models available on request		3) Non-linear load, crest factor 3:1					
2) Protection key:		4) Up to 25°C ambient					
a) output short circuit		5) Switches off when no external AC source available					
b) overload		6) Programmable relay that can a.o. be set for general alarm, DC under voltage or genset start/stop function					
c) battery voltage too high		AC rating: 230 V/4A					
d) battery voltage too low		DC rating: 4 A up to 35 VDC, 1 A up to 60 VDC					
e) temperature too high		7) A.o. to communicate with a Lithium Ion battery BMS					
f) 230 VAC on inverter output							
g) input voltage ripple too high							



Digital Multi Control Panel

A convenient and low cost solution for remote monitoring, with a rotary knob to set PowerControl and PowerAssist levels.



VE.Bus Smart Dongle

Measures battery voltage and temperature and allows monitoring and control of Multis and Quattros with a smartphone or other Bluetooth enabled device.



Computer controlled operation and monitoring

Several interfaces are available:



Color Control GX and other GX devices

Monitoring and control. Locally, and also remotely on the [VRM Portal](#).



MK3-USB (VE.Bus to USB interface)

Connects to a USB port ([see 'A guide to VEConfigure'](#))



VE.Bus to NMEA 2000 interface

Connects the device to a NMEA2000 marine electronics network. See the [NMEA2000 & MFD integration guide](#)



BMV-712 Smart Battery Monitor

Use a smartphone or other Bluetooth enabled device to:

- customize settings,
- monitor all important data on single screen,
- view historical data, and to update the software when new features become available.

Two AC inputs with integrated transfer switch

The Quattro can be connected to two independent AC sources, for example the public grid and a generator, or two generators. The Quattro will automatically connect to the active source.

Two AC Outputs

The main output has no-break functionality. The Quattro takes over the supply to the connected loads in the event of a grid failure or when shore/generator power is disconnected. This happens so fast (less than 20 milliseconds) that computers and other electronic equipment will continue to operate without disruption.

The second output is live only when AC is available on one of the inputs of the Quattro. Loads that should not discharge the battery, like a water heater for example, can be connected to this output.

Split phase option

A split phase AC source can be obtained by connecting our autotransformer (see data sheet on www.victronenergy.com) to a 'European' inverter programmed to supply 240V / 60Hz.

Three phase capability

Three units can be configured for three phase output. But that's not all: up to 4 sets of three 15kVA units can be parallel connected to provide 144kW / 180kVA inverter power and 2400A charging capacity.

PowerControl – Dealing with limited generator, shore side or grid power

The Quattro is a very powerful battery charger. It will therefore draw a lot of current from the generator or shore side supply (16A per 5kVA Quattro at 230VAC). A current limit can be set on each AC input. The Quattro will then take account of other AC loads and use whatever is spare for charging, thus preventing the generator or mains supply from being overloaded.

PowerAssist – Boosting shore or generator power

This feature takes the principle of PowerControl to a further dimension allowing the Quattro to supplement the capacity of the alternative source. Where peak power is so often required only for a limited period, the Quattro will make sure that insufficient mains or generator power is immediately compensated for by power from the battery. When the load reduces, the spare power is used to recharge the battery.

Solar energy: AC power available even during a grid failure

The Quattro can be used in off grid as well as grid connected PV and other alternative energy systems. Loss of mains detection software is available.

System configuring

- In case of a stand-alone application, if settings have to be changed, this can be done in a matter of minutes with a DIP switch setting procedure.
- Parallel and three phase applications can be configured with VE.Bus Quick Configure and VE.Bus System Configurator software.
- Off grid, grid interactive and self-consumption applications, involving grid-tie inverters and/or MPPT Solar Chargers can be configured with Assistants (dedicated software for specific applications).

On-site Monitoring and control

Several options are available: Battery Monitor, Multi Control Panel, Color Control GX or other GX devices, smartphone or tablet (Bluetooth Smart), laptop or computer (USB or RS232).

Remote Monitoring and control

Color Control GX or other GX devices.

Data can be stored and displayed on our VRM (Victron Remote Management) website, free of charge.

Remote configuring

When connected to the Ethernet, systems with a Color Control GX or other GX device can be accessed and settings can be changed remotely.



Quattro
48/5000/70-100/100



Quattro
48/15000/200-100/100



Color Control GX, showing a PV application

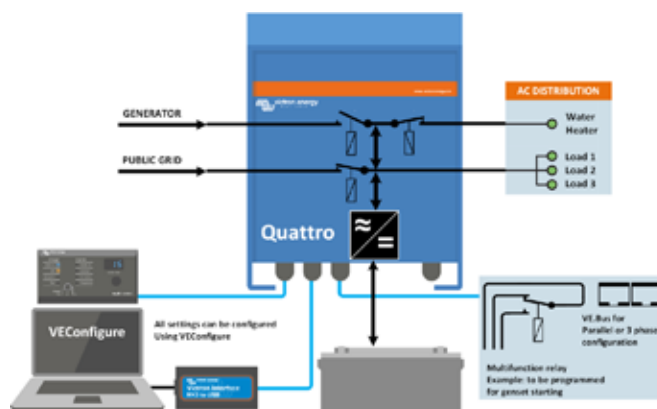

Quattro	12/3000/120-50/50 24/3000/70-50/50	12/5000/220-100/100 24/5000/120-100/100 48/5000/70-100/100	24/8000/200-100/100 48/8000/110-100/100	48/10000/140-100/100	48/15000/200-100/100
PowerControl / PowerAssist	Yes				
Integrated Transfer switch	Yes				
AC inputs (2x)	Input voltage range: 187-265 VAC Input frequency: 45 – 65 Hz Power factor: 1				
Maximum feed through current (A)	2x 50	2x100	2x100	2x100	2x100
INVERTER					
Input voltage range (V DC)	9,5 – 17V 19 – 33V 38 – 66V				
Output (1)	Output voltage: 230 VAC ± 2% Frequency: 50 Hz ± 0,1%				
Cont. output power at 25°C (VA) (3)	3000	5000	8000	10000	15000
Cont. output power at 25°C (W)	2400	4000	6400	8000	12000
Cont. output power at 40°C (W)	2200	3700	5500	6500	10000
Cont. output power at 65°C (W)	1700	3000	3600	4500	7000
Peak power (W)	6000	10000	16000	20000	25000
Maximum efficiency (%)	93 / 94	94 / 94 / 95	94 / 96	96	96
Zero load power (W)	20 / 20	30 / 30 / 35	60 / 60	60	110
Zero load power in AES mode (W)	15 / 15	20 / 25 / 30	40 / 40	40	75
Zero load power in Search mode (W)	8 / 10	10 / 10 / 15	15 / 15	15	20
CHARGER					
Charge voltage 'absorption' (V DC)	14,4 / 28,8	14,4 / 28,8 / 57,6	28,8 / 57,6	57,6	57,6
Charge voltage 'float' (V DC)	13,8 / 27,6	13,8 / 27,6 / 55,2	27,6 / 55,2	55,2	55,2
Storage mode (V DC)	13,2 / 26,4	13,2 / 26,4 / 52,8	26,4 / 52,8	52,8	52,8
Charge current house battery (A) (4)	120 / 70	220 / 120 / 70	200 / 110	140	200
Charge current starter battery (A)	4 (12V and 24V models only)				
Battery temperature sensor	Yes				
GENERAL					
Auxiliary output (A) (5)	25	50	50	50	50
Programmable relay (6)	3x	3x	3x	3x	3x
Protection (2)	a-g				
VE.Bus communication port	For parallel and three phase operation, remote monitoring and system integration				
General purpose com. port	2x	2x	2x	2x	2x
Remote on-off	Yes				
Common Characteristics	Operating temp.: -40 to +65°C Humidity (non-condensing): max. 95%				
Maximum altitude	3500 m				
ENCLOSURE					
Common Characteristics	Material & Colour: aluminium (blue RAL 5012) Protection category: IP 21				
Battery-connection	Four M8 bolts (2 plus and 2 minus connections)				
230 V AC-connection	Screw terminals 13 mm ² (6 AWG)	Bolts M6	Bolts M6	Bolts M6	Bolts M6
Weight (kg)	19	34 / 30 / 30	45 / 41	51	72
Dimensions (hwxwd in mm)	362 x 258 x 218	470 x 350 x 280 444 x 328 x 240 444 x 328 x 240	470 x 350 x 280	470 x 350 x 280	572 x 488 x 344
STANDARDS					
Safety	EN-IEC 60335-1, EN-IEC 60335-2-29, EN-IEC 62109-1				
Emission, Immunity	EN 55014-1, EN 55014-2, EN-IEC 61000-3-2, EN-IEC 61000-3-3, IEC 61000-6-1, IEC 61000-6-2, IEC 61000-6-3				
Road vehicles	12V and 24V models: ECE R10-4				
Anti-islanding	See our website				
1) Can be adjusted to 60 HZ. 120 V models available on request		3) Non-linear load, crest factor 3:1			
2) Protection key:		4) Up to 25°C ambient			
a) output short circuit		5) Switches off when no external AC source available			
b) overload		6) Programmable relay that can a.o. be set for general alarm,			
c) battery voltage too high		DC under voltage or genset start/stop function			
d) battery voltage too low		AC rating: 230 V / 4 A			
e) temperature too high		DC rating: 4 A up to 35 VDC, 1 A up to 60 VDC			
f) 230 VAC on inverter output					
g) input voltage ripple too high					



Digital Multi Control Panel

A convenient and low cost solution for remote monitoring, with a rotary knob to set PowerControl and PowerAssist levels.

Computer controlled operation and monitoring

Several interfaces are available:



Color Control GX and other GX devices

Monitoring and control. Locally, and also remotely on the [VRM Portal](#).



BMV-712 Smart Battery Monitor

Use a smartphone or other Bluetooth enabled device to:

- customize settings,
- monitor all important data on single screen,
- view historical data, and to update the software when new features become available.



VE.Bus Smart Dongle

Measures battery voltage and temperature and allows monitoring and control of Multis and Quattros with a smartphone or other Bluetooth enabled device.



MK3-USB (VE.Bus to USB interface)

Connects to a USB port ([see 'A guide to VEConfigure'](#))



VE.Bus to NMEA 2000 interface

Connects the device to a NMEA2000 marine electronics network. See the [NMEA2000 & MFD integration guide](#)



A MultiPlus, plus ESS (Energy Storage System) functionality

The MultiPlus-II is a multifunctional inverter/charger with all the features of the MultiPlus, plus an external current sensor option which extends the PowerControl and PowerAssist function to 50A resp. 100A. The MultiPlus-II is ideally suited for professional marine, yachting, vehicle and land based off-grid applications. It also has built-in anti-islanding functionality, and an increasingly long list of country approvals for ESS application. Several system configurations are possible. For more detailed information see the ESS Design and configuration manual.

PowerControl and PowerAssist - Boosting the capacity of the grid or a generator

A maximum grid or generator current can be set. The MultiPlus-II will then take account of other AC loads and use whatever is extra for battery charging, thus preventing the generator or grid from being overloaded (PowerControl function).

PowerAssist takes the principle of PowerControl to a further dimension. Where peak power is so often required only for a limited period, the MultiPlus-II will compensate insufficient generator, shore or grid power with power from the battery. When the load reduces, the spare power is used to recharge the battery.

Solar energy: AC power available even during a grid failure

The MultiPlus-II can be used in off grid as well as grid connected PV and other alternative energy systems. It is compatible with both solar charger controllers and grid-tie inverters.

Two AC Outputs

The main output has no break functionality. The MultiPlus-II takes over the supply to the connected loads in the event of a grid failure or when shore/generator power is disconnected. This happens so fast (less than 20 milliseconds) that computers and other electronic equipment will continue to operate without disruption.

The second output is live only when AC is available on the input of the MultiPlus-II. Loads that should not discharge the battery, like a water heater for example, can be connected to this output.

Virtually unlimited power thanks to parallel (not for the 8k, 10k and 15k models) and three phase operation

Up to 6 Multis can operate in parallel to achieve higher power output. Six 48/5000/70 units, for example, will provide 25 kW / 30 kVA output power with 420 Amps charging capacity.

In addition to parallel connection, three units of the same model can be configured for three phase output. But that's not all: up to 6 sets of three units can be parallel connected for a 75 kW / 90 kVA inverter and more than 1200 Amps charging capacity.

On-site system configuring, monitoring and control

Settings can be changed in a matter of minutes with VEConfigure software (computer or laptop and MK3-USB interface needed).

Several monitoring and control options are available: Cerbo GX, Color Control GX, Venus GX, Octo GX, CANvu GX, laptop, computer, Bluetooth (with the optional VE.Bus Smart dongle), Battery Monitor, Digital Multi Control Panel.

Remote configuring and monitoring

Install a Cerbo GX or other GX product to connect to the internet.

Operational data can be stored and displayed on our VRM (Victron Remote Management) website, free of charge. When connected to the internet, systems can be accessed remotely, and settings can be changed.

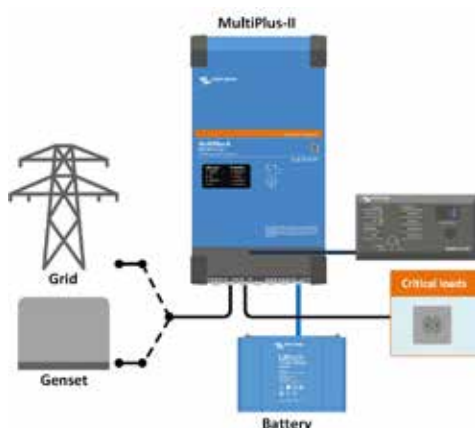

Standard marine, mobile or off-grid application

Loads that should shut down when AC input power is not available can be connected to a second output (not shown). These loads will be taken into account by the PowerControl and PowerAssist function in order to limit AC input current to a safe value when AC power is available.

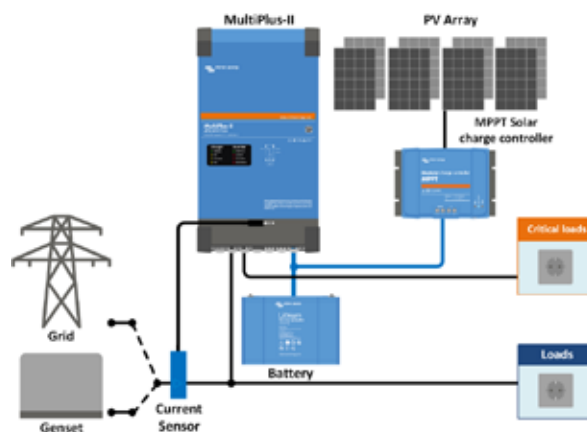

Grid parallel topology with MPPT solar charge controller

The MultiPlus-II will use data from the external AC current sensor (must be ordered separately) or power meter to optimise self-consumption and, if required, to prevent grid feed. In case of a power outage, the MultiPlus-II will continue to supply the critical loads



GX Touch and Cerbo GX
Provides intuitive system control and monitoring. Besides system monitoring and control the Cerbo GX enables access to our free remote monitoring website: the VRM Online Portal



VRM Portal
Our free remote monitoring website (VRM) will display all your system data in a comprehensive graphical format. System settings can be changed remotely via the portal. Alarms can be received by e-mail.



VRM app
Monitor and manage your Victron Energy system from your smart phone and tablet. Available for both iOS and Android.



VE.Bus Smart Dongle
Measures battery voltage and temperature and allows monitoring and control with a smart phone or other Bluetooth enabled device.

MultiPlus-II 230V	12/3000/120-32 24/3000/70-32 48/3000/35-32	24/5000/120-50 48/5000/70-50	48/8000/ 110-100	48/10000/ 140-100	48/15000/ 200-100
PowerControl & PowerAssist	Yes				
Transfer switch	32 A	50 A	100 A	100 A	100 A
Maximum AC input current	32 A	50 A	100 A	100 A	100 A
INVERTER					
DC Input voltage range	12V - 9,5-17 V		24V - 19-33V	48V - 38-66 V	
Output	Output voltage: 230 VAC ± 2% Frequency: 50 Hz ± 0,1% (1)				
Cont. output power at 25°C (3)	3000 VA	5000 VA	8000 VA	10000 VA	15000 VA
Cont. output power at 25°C	2400 W	4000 W	6400 W	8000 W	12000 W
Cont. output power at 40°C	2200 W	3700 W	5500 W	7000 W	10000 W
Cont. output power at 65°C	1700 W	3000 W	4000 W	6000 W	7000 W
Max apparent feed-in power	3000 VA	5000 VA	8000 VA	10000 VA	15000 VA
Peak power	5500 W	9000 W	15000 W	18000 W	27000 W
Maximum efficiency	93%/94%/95%		96%	95%	96%
Zero load power	13 / 13 / 11 W	18 W	29 W	38 W	55 W
Zero load power in AES mode	9 / 9 / 7 W	12 W	19 W	27 W	39 W
Zero load power in Search mode	3 / 3 / 2 W	2 W	3 W	4 W	6 W
CHARGER					
AC Input	Input voltage range: 187-265 VAC Input frequency: 45 – 65 Hz				
Charge voltage 'absorption'	14,4 / 28,8 / 57,6 V				
Charge voltage 'float'	13,8 / 27,6 / 55,2 V				
Storage mode	13,2 / 26,4 / 52,8 V				
Max. battery charge current (4)	120 / 70 / 35 A	120 / 70 A	110 A	140 A	200 A
Battery temperature sensor	Yes				
GENERAL					
Auxiliary output	Yes (32A)		Yes (50A)		
External AC current sensor (optional)	50A or 100A				
Programmable relay (5)	Yes				
Protection (2)	a – g				
VE.Bus communication port	For parallel (not for 8k, 10k and 15k models) and three phase operation, remote monitoring and system integration				
General purpose com. port	Yes, 2x				
Remote on-off	Yes				
Operating temperature range	-40 to +65°C (fan assisted cooling)				
Humidity (non-condensing)	max 95%				
ENCLOSURE					
Material & Colour	Steel, blue RAL 5012				
Protection category	IP22				
Battery-connection	M8 bolts		Four M8 bolts (2 plus and 2 minus connections)		
230 V AC-connection	Screw terminals 13 mm ² (6 AWG)		Bolts M6	Bolts M6	Bolts M6
Weight	19 kg	30 kg	42 kg	49 kg	80 kg
Dimensions (hxxwxd) mm	546 x 275 x 147	607 x 330 x 149 565 x 320 x 149	642 x 363 x 206	677 x 363 x 206	810 x 405 x 217
	499 x 268 x 141				
	499 x 268 x 141				
STANDARDS					
Safety	EN-IEC 60335-1, EN-IEC 60335-2-29, EN-IEC 62109-1, EN-IEC 62109-2				
Emission, Immunity	EN 55014-1, EN 55014-2 EN-IEC 61000-3-2, EN-IEC 61000-3-3 IEC 61000-6-1, IEC 61000-6-2, IEC 61000-6-3				
Uninterruptible power supply	Please consult the certificates on our website.				
Anti-islanding	Please consult the certificates on our website.				
1) Can be adjusted to 60 Hz 2) Protection key: a) output short circuit b) overload c) battery voltage too high d) battery voltage too low e) temperature too high f) 230 VAC on inverter output g) input voltage ripple too high 3) Non-linear load, crest factor 3:1 4) Up to 25°C ambient 5) Programmable relay which can be set for general alarm, DC under voltage or genset start/stop function. AC rating: 230V / 4A, DC rating: 4A up to 35VDC and 1A up to 60VDC					



Connection Area MultiPlus-II 3k



Current sensor 100A:50mA
To implement PowerControl and PowerAssist and to optimize self-consumption with external current sensing. Maximum current: 50A resp. 100A. Length of connection cable: 1 m.



Digital Multi Control Panel
A convenient and low-cost solution for remote monitoring, with a rotary knob to set PowerControl and PowerAssist levels.

MultiPlus-II inverter/charger 3kVA & 5kVA 230V GX



A MultiPlus-II with LCD and GX functionality

The MultiPlus-II GX integrates a MultiPlus-II inverter/charger and a GX device with a 2 x 16 character display.

Display and Wi-Fi

The display reads battery, inverter and solar charge controller parameters. The same parameters can be accessed with a smartphone or other Wi-Fi enabled device.

GX device

The integrated GX device includes:

- A BMS-Can interface. This can be used to connect to a compatible CAN-bus managed battery. Note that this not a VE.Can compatible port.
- A USB port.
- A Ethernet port.
- A VE.Direct port.

Applications

The MultiPlus-II GX is intended for applications where additional interfacing with other products and/or remote monitoring is required, such as on-grid or off-grid energy storage systems and certain mobile applications.

Parallel and three phase operation

Only one GX unit is needed in case of Parallel and three phase operation.

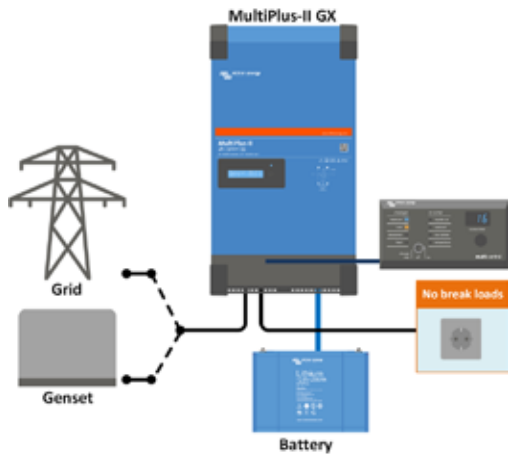

Standard marine, mobile or off-grid application

Loads that should shut down when AC input power is not available can be connected to a second output (not shown). These loads will be taken into account by the PowerControl and PowerAssist function in order to limit AC input current to a safe value when AC power is available.

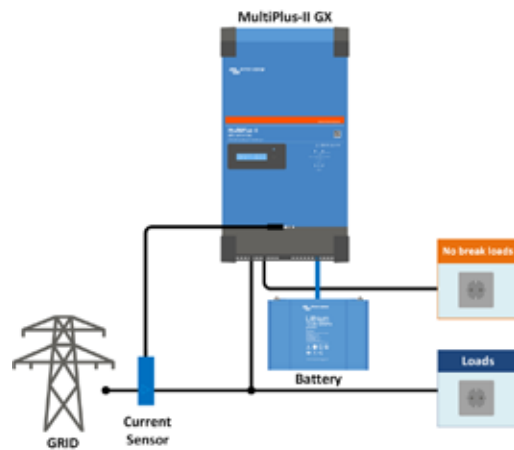

Standard mobile or off-grid application with external current sensor

Maximum current sensing range: 50 A resp 100 A

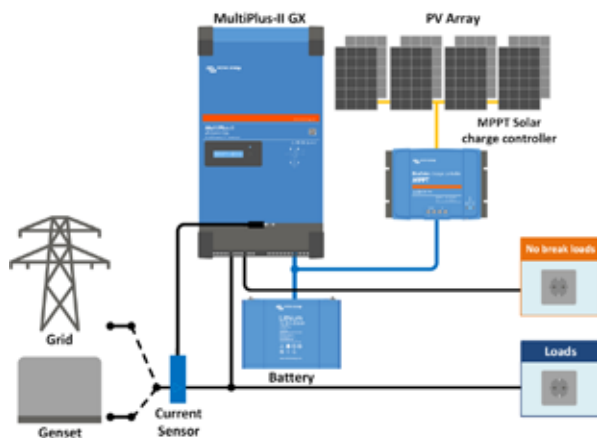

Grid parallel topology with MPPT solar charge controller

The MultiPlus-II will use data from the external AC current sensor (must be ordered separately) or power meter to optimise self-consumption and, if required, to prevent grid feed. In case of a power outage, the MultiPlus-II will continue to supply the critical loads

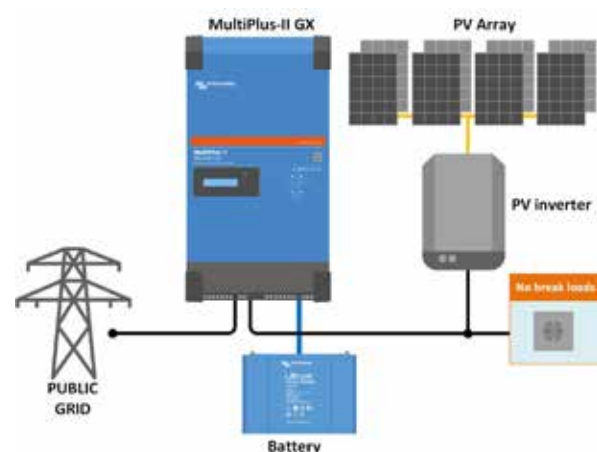

Grid in-line topology with PV inverter

PV power is directly converted to AC. The MultiPlus-II will use excess PV power to charge the batteries or to feed power back into the grid, and will discharge the battery or use power from the grid to supplement a shortage of PV power. In case of a power outage, the MultiPlus-II will disconnect the grid and continue to supply the loads.



VRM Portal

Our free remote monitoring website (VRM) will display all your system data in a comprehensive graphical format. System settings can be changed remotely via the portal. Alarms can be received by e-mail.



VRM app for Wi-Fi

Monitor and manage your Victron Energy system from your smart phone and tablet. Available for both iOS and Android.



GX GSM

A cellular modem; providing a mobile internet for the system and connection to Victron Remote Management (VRM).
Optional: outdoor GSM antenna and GPS antenna.
For more detail please enter *GX GSM* in the search box on our website



Connection Area



Current sensor 100 A:50 mA

To implement PowerControl and PowerAssist and to optimize self-consumption with external current sensing.
Maximum current: 50 A resp. 100 A.
Length of connection cable: 1 m.



Digital Multi Control Panel

A convenient and low-cost solution for remote monitoring, with a rotary knob to set PowerControl and PowerAssist levels.

MultiPlus-II GX	24/3000/70-32	48/3000/35-32	48/5000/70-50
PowerControl & PowerAssist	Yes		
Transfer switch	32 A		50 A
Maximum AC input current	32 A		50 A
Auxiliary output	Yes (32 A)		
INVERTER			
DC Input voltage range	19 – 33 V	38 – 66 V	
Output	Output voltage: 230 VAC ± 2 % Frequency: 50 Hz ± 0,1 % (1)		
Cont. output power at 25 °C (3)	3000 VA	5000 VA	
Cont. output power at 25 °C	2400 W	4000 W	
Cont. output power at 40 °C	2200 W	3700 W	
Cont. output power at 65 °C	1700 W	3000 W	
Maximum apparent feed-in power	3000 VA	5000 VA	
Peak power	5500 W	9000 W	
Maximum efficiency	94 %	95 %	96 %
Zero load power	13 W	11 W	18 W
Zero load power in AES mode	9 W	7 W	12 W
Zero load power in Search mode	3 W	2 W	2 W
CHARGER			
AC Input	Input voltage range: 187-265 VAC Input frequency: 45 – 65 Hz		
Charge voltage 'absorption'	28,8 V	57,6 V	
Charge voltage 'float'	27,6 V	55,2 V	
Storage mode	26,4 V	52,8 V	
Maximum battery charge current (4)	70 A	35 A	70 A
Battery temperature sensor	Yes		
GENERAL			
Interfaces	BMS-Can, USB, Ethernet, VE.Direct, Wi-Fi		
External AC current sensor (optional)	50 A	100 A	
Programmable relay (5)	Yes		
Protection (2)	a – g		
VE.Bus communication port	For parallel and three phase operation, remote monitoring and system integration		
General purpose com. port	Yes, 2x		
Remote on-off	Yes		
Operating temperature range	-40 to +65 °C (fan assisted cooling)		
Humidity (non-condensing)	max 95 %		
ENCLOSURE			
Material & Colour	Steel, blue RAL 5012		
Protection category	IP22		
Battery-connection	M8 bolts		
230 V AC-connection	Screw terminals 13 mm ² (6 AWG)		
Weight	20 kg	31 kg	
Dimensions (hxwx d) mm	506 x 275 x 147	565 x 323 x 148	
STANDARDS			
Safety	EN-IEC 60335-1, EN-IEC 60335-2-29, EN-IEC 62109-1, EN-IEC 62109-2		
Emission, Immunity	EN 55014-1, EN 55014-2 EN-IEC 61000-3-2, EN-IEC 61000-3-3 IEC 61000-6-1, IEC 61000-6-2, IEC 61000-6-3		
Uninterruptible power supply	IEC 62040-1		
Anti-islanding	Please consult the certificates on our website.		
1) Can be adjusted to 60 Hz	3) Non-linear load, crest factor 3:1		
2) Protection key:	4) Up to 25 °C ambient		
a) output short circuit	5) Programmable relay which can be set for general alarm, DC under voltage or genset start/stop function.		
b) overload	AC rating: 230 V / 4 A, DC rating: 4 A up to 35 VDC and 1 A up to 60 VDC		
c) battery voltage too high			
d) battery voltage too low			
e) temperature too high			
f) 230 VAC on inverter output			
g) input voltage ripple too high			

MultiPlus
 24/3000/70

Multifunctional, with intelligent power management

The MultiPlus is a powerful true sine wave inverter, a sophisticated battery charger that features adaptive charge technology, and a high-speed AC transfer switch in a single compact enclosure. Next to these primary functions, the MultiPlus has several advanced features, as outlined below.

Two AC Outputs

The main output has no-break functionality. The MultiPlus takes over the supply to the connected loads in the event of a grid failure or when shore-/generator power is disconnected. This happens so fast (less than 20 milliseconds) that computers and other electronic equipment will continue to operate without disruption.

The second output is live only when AC is available on the input of the MultiPlus. Loads that should not discharge the battery, like a water heater for example, can be connected to this output (second output available on models rated at 3kVA and more).

Virtually unlimited power thanks to parallel operation

Up to six Multis can operate in parallel to achieve higher power output. Six 24/3000/70 units, for example, provide 15kW / 18kVA output power with 420 Amps of charging capacity.

Three phase capability

In addition to parallel connection, three units can be configured for three-phase output. But that's not all: with three strings of six parallel units a 45 kW / 54 kVA three phase inverter and 1260 A charger can be built.

Split phase options

Two units can be stacked to provide 120-0-120 V, and additional units can be paralleled up to a total of 6 units per phase, to supply up to 30 kW / 36 kVA of split phase power.

Alternatively, a split phase AC source can be obtained by connecting our autotransformer (see data sheet on www.victronenergy.com) to a 'European' inverter programmed to supply 240 V / 60 Hz.

PowerControl - Dealing with limited generator, shore side or grid power

The MultiPlus is a very powerful battery charger. It will therefore draw a lot of current from the generator or shore side supply (nearly 20 A per 3 kVA MultiPlus at 120 VAC). With the Multi Control Panel a maximum generator or shore current can be set. The MultiPlus will then take account of other AC loads and use whatever is extra for charging, thus preventing the generator or shore supply from being overloaded.

PowerAssist - Boosting the capacity of shore or generator power

This feature takes the principle of PowerControl to a further dimension. It allows the MultiPlus to supplement the capacity of the alternative source. Where peak power is so often required only for a limited period, the MultiPlus will make sure that insufficient shore or generator power is immediately compensated for by power from the battery. When the load reduces, the spare power is used to recharge the battery.

Four stage adaptive charger and dual bank battery charging

The main output provides a powerful charge to the battery system by means of advanced 'adaptive charge' software. The software fine-tunes the three stage automatic process to suit the condition of the battery, and adds a fourth stage for long periods of float charging. The adaptive charge process is described in more detail on the Phoenix Charger datasheet and on our website, under Technical Information. In addition to this, the MultiPlus will charge a second battery using an independent trickle charge output intended for a main engine or generator starter battery.

System configuring has never been easier

After installation, the MultiPlus is ready to go.

If settings have to be changed, this can be done in a matter of minutes with a DIP switch setting procedure. Even parallel and 3-phase operation can be programmed with DIP switches: no computer needed!

Alternatively, VE.Net can be used instead of the DIP switches.

And sophisticated software (VE.Bus Quick Configure and VE.Bus System Configurator) is available to configure several new, advanced, features.

MultiPlus Compact
 12/2000/80

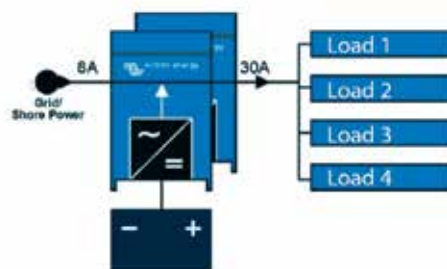
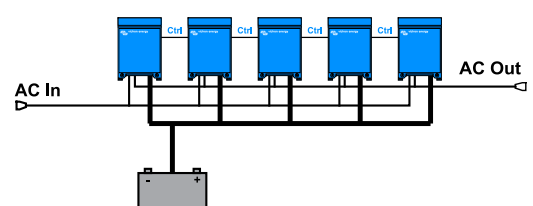
PowerAssist with 2x MultiPlus in parallel

Five parallel units: output power 12,5 kW

MultiPlus	12 Volt 24 Volt	12/2000/80 24/2000/50	12/3000/120 24/3000/70
PowerControl			Yes
PowerAssist			Yes
Transfer switch (A)			50
Parallel and 3-phase operation			Yes
INVERTER			
Input voltage range (V DC)		9,5 – 17 V	19 – 33 V
Output		Output voltage: 120 VAC ± 2%	Frequency: 60 Hz ± 0,1% (1)
Cont. output power at 25°C / 77°F (VA) (3)	2000		3000
Cont. output power at 25°C / 77°F (W)	1600		2400
Cont. output power at 40°C / 104°F (W)	1450		2200
Cont. output power at 65°C / 150°F (W)	1100		1700
Peak power (W)	4000		6000
Maximum efficiency (%)	92 / 94		93 / 94
Zero load power (W)	9 / 11		20 / 20
Zero load power in AES mode (W)	7 / 8		15 / 15
Zero load power in Search mode (W)	3 / 4		8 / 10
CHARGER			
AC Input		Input voltage range: 95-140 VAC	Input frequency: 45 – 65 Hz Power factor: 1
Charge voltage 'absorption' (V DC)			14,4 / 28,8
Charge voltage 'float' (V DC)			13,8 / 27,6
Storage mode (V DC)			13,2 / 26,4
Charge current house battery (A) (4)	80 / 50		120 / 70
Charge current starter battery (A)			4
Battery temperature sensor			yes
GENERAL			
Auxiliary output (5)		n. a.	Yes (32A)
Programmable relay (6)		Yes (1x)	Yes (3x)
Protection (2)			a - g
VE.Bus communication port		For parallel and three phase operation, remote monitoring and system integration	
General purpose com. port (7)		n. a.	Yes (2x)
Remote on-off			Yes
Common Characteristics		Operating temp. range: -40 - +65°C / -40 to 150°F (fan assisted cooling)	Humidity (non-condensing): max 95%
ENCLOSURE			
Common Characteristics		Material & Colour: aluminium (blue RAL 5012)	Protection category: IP 21
Battery-connection		M8 bolts	M8 bolts (2 plus and 2 minus connections)
120 V AC-connection		Screw-terminal 6 AWG (13 mm ²)	Screw-terminal 6 AWG (13mm ²)
Weight		13 kg 25 lbs.	19kg 40 lbs.
Dimensions (hxwx d in mm and inches)		520x255x125 mm 20.5x10.0x5.0 inch	362x258x218 mm 14.3x10.2x8.6 inch
STANDARDS			
Safety		UL 458, EN-IEC 60335-1, EN-IEC 60335-2-29	UL 1741, UL 458, EN-IEC 60335-1, EN-IEC 60335-2-29
Emission and Immunity		EN-IEC 61000-3-2/3-3/, EN-IEC 61000-6-1/6-2/6-3	EN-IEC 61000-3-2/3-3/, EN-IEC 61000-6-1/6-2/6-3
1) Can be adjusted to 50 HZ;		3) Non-linear load, crest factor 3:1	
2) Protection key:		4) Up to 75°F ambient	
a) output short circuit		5) Switches off when no external AC source available	
b) overload		6) Programmable relay that can a.o. be set for general alarm,	
c) battery voltage too high		DC under voltage or genset start/stop function	
d) battery voltage too low		AC rating: 120 V/4 A	
e) temperature too high		DC rating: 4 A up to 35 VDC, 1 A up to 60 VDC	
f) 120 VAC on inverter output		7) A.o. to communicate with a Lithium Ion battery BMS	
g) input voltage ripple too high			



Digital Multi Control

A convenient and low cost solution for remote monitoring, with a rotary knob to set PowerControl and PowerAssist levels.



VE.Bus Smart Dongle

Measures battery voltage and temperature and allows monitoring and control of Multis and Quattros with a smartphone or other Bluetooth enabled device.



Computer controlled operation and monitoring

Several interfaces are available:

Color Control GX and other GX devices

Provides monitor and control. Locally, and also remotely on the [VRM Portal](#).

MK3-USB VE.Bus to USB interface

Connects to a USB port ([see 'A guide to VEConfigure'](#))



VE.Bus to NMEA 2000 interface

Connects the device to a NMEA2000 marine electronics network. See the [NMEA2000 & MFD integration guide](#)



BMV-712 Smart Battery Monitor

Use a smartphone or other Bluetooth enabled device to:

- customize settings,
- monitor all important data on single screen,
- view historical data, and to update the software when new features become available.

MultiPlus-II inverter/charger 3kVA 2x120V

120/240V input and output, or 120V input and output (always 120V output when in inverter mode)

The AC input can be supplied from a split phase 120/240V source, or single phase 120V source.

When an AC source is available, the MultiPlus will feed through the AC to its output. The output will therefore mirror the AC input.

The inverter/charger connects to the neutral and the preferred input line (L1). Power needed to charge the batteries will therefore be drawn from L1.

The MultiPlus switches to inverter operation when no AC source is available. The inverter output is 120V single phase. In invert mode, the MultiPlus connects both output lines (L1 and L2) together to provide 120VAC to loads on either line.

Any 240V loads will therefore be supplied only when the MultiPlus is supplied by a split phase AC source. This prevents heavy loads such as water heaters or 240V air conditioners from discharging the battery.

PowerControl and PowerAssist - Boosting the capacity of the grid or a generator

A maximum grid or generator current can be set. The MultiPlus will then take account of other AC loads and use whatever is extra for battery charging, thus preventing the generator or grid from being overloaded (PowerControl function).

PowerAssist takes the principle of PowerControl to a further dimension. Where peak power is so often required only for a limited period, the MultiPlus-II will compensate insufficient generator, shore or grid power with power from the battery. When the load reduces, the spare power is used to recharge the battery (available on L1 input only).

Two AC Outputs

The main output has no break functionality. The MultiPlus takes over the supply to the connected 120V loads in the event of a grid failure or when shore/generator power is disconnected. The transfer time of the L1 output is less than 18 milliseconds so that computers and other electronic equipment will continue to operate without disruption. The transfer time of the L2 output is longer: approximately 40 milliseconds.

The second (auxiliary) output is live only when AC is available on the input of the MultiPlus. Loads that should not discharge the battery can be connected to this output.

Virtually unlimited power thanks to parallel and three phase operation

Up to 6 Multis can operate in parallel to achieve higher power output.

In addition to parallel connection, three units of the same model can be configured for three phase output.

In multi-phase setups, L2 is disabled on all units.

On-site system configuring, monitoring and control

Settings can be changed in a matter of minutes with VEConfigure software (computer or laptop and MK3-USB interface needed).

Several monitoring and control options are available: Cerbo GX, Color Control GX, Venus GX, CANvu GX, laptop, computer, Bluetooth (with the optional VE.Bus Smart dongle), Battery Monitor, Digital Multi Control Panel.

Remote configuring and monitoring

Install a Cerbo GX or other GX product to connect to the internet.

Operational data can be stored and displayed on our VRM (Victron Remote Management) website, free of charge.

When connected to the internet, systems can be accessed remotely, and settings can be changed.

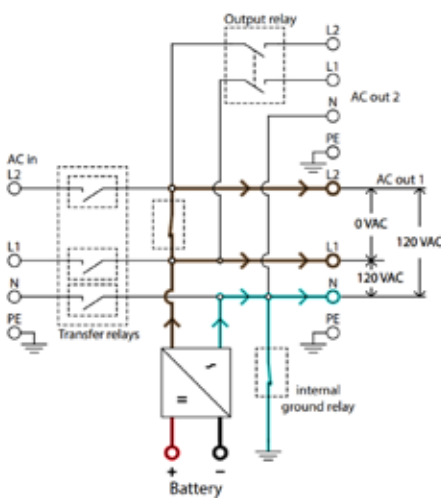

Power flow: inverter mode

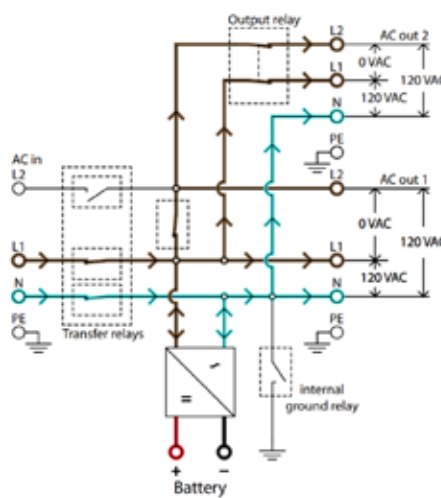

Power flow, 120VAC-input

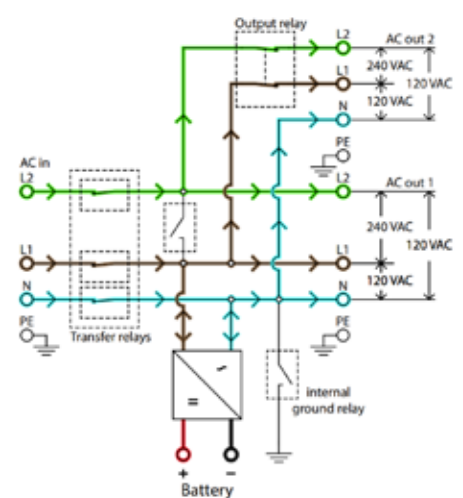

Power flow, split phase input



Cerbo GX with GX Touch 50

Provides intuitive system control and monitoring
Besides system monitoring and control the Cerbo enables access to our free remote monitoring website: the VRM Online Portal



VRM Portal

Our free remote monitoring website (VRM) will display all system data in a comprehensive graphical format. System settings can be changed remotely via the portal. Alarms can be received by e-mail.



VRM app

Monitor and manage your Victron Energy system from your smart phone and tablet. Available for both iOS and Android.



VE.Bus Smart Dongle

Measures battery voltage and temperature and allows monitoring and control with a smart phone or other Bluetooth enabled device.



Connection Area

MultiPlus-II 2x120V	12/3000/120-50	24/3000/70-50
PowerControl & PowerAssist	Yes (on L1 input)	
Transfer switch	50 A	
Maximum AC input current	50A (each leg)	
INVERTER		
DC Input voltage range	9,5 – 17 V	19-33V
Output when in inverter mode	Output voltage: 120 VAC ± 2% Frequency: 60 Hz ± 0,1% (1)	
Cont. output power at 25°C (3)	3000 VA	
Cont. output power at 25°C	2400 W	
Cont. output power at 40°C	2200 W	
Cont. output power at 65°C	1700 W	
Maximum apparent feed-in power	2500 VA	
Peak power	5500 W	
Maximum efficiency	93%	94%
Zero load power	15W	11W
Zero load power in AES mode	10W	8W
Zero load power in Search mode	4W	4W
CHARGER		
AC Input	Split phase: 180-280 VAC	45 – 65 Hz
	Single phase: 90-140 VAC	45 – 65 Hz
Charge voltage 'absorption'	14,4 V	28,8 V
Charge voltage 'float'	13,8 V	27,6 V
Storage mode	13,2 V	26,4 V
Maximum battery charge current (4)	120 A	70 A
Battery temperature sensor	Yes	
GENERAL		
Auxiliary output (5)	50 A (each leg) See note 8	
External AC current sensor (optional)	100 A	
Programmable relay (6)	Yes	
Protection (2)	a – g	
VE.Bus communication port	For parallel and three phase operation, remote monitoring and system integration	
General purpose com. Port (7)	Yes, 2x	
Remote on-off	Yes	
Operating temperature range	-40 to +65°C (-40 -150°F) Fan assisted cooling	
Humidity (non-condensing)	max 95%	
ENCLOSURE		
Material & Colour	Steel, blue RAL 5012	
Protection category	IP22	
Battery-connection	2x2 M8 bolts	2 M8 bolts
120/240 V AC-connection	Screw terminals 21 mm ² (4 AWG)	
Weight	22 kg (48 lb)	
Dimensions (hwxwd)	578 x 275 x 148 mm (23 x 11 x 6 inch)	578 x 275 x 148 mm (23 x 11 x 6 inch)
STANDARDS		
Safety	EN-IEC 60335-1, EN-IEC 60335-2-29, UL 458	
Emission, Immunity	EN 55014-1, EN 55014-2 EN-IEC 61000-3-2, EN-IEC 61000-3-3 IEC 61000-6-1, IEC 61000-6-2, IEC 61000-6-3	
1) Can be adjusted to 50 Hz 2) Protection key: a) output short circuit b) overload c) battery voltage too high d) battery voltage too low e) temperature too high f) 120 VAC on inverter output g) input voltage ripple too high 3) Non-linear load, crest factor 3:1 4) Up to 75 ° F / 25 ° C ambient 5) Switches off when no external AC source available 6) Programmable relay that can a.o. be set for general alarm, DC under voltage or genset start/stop function DC rating: 120 V/4 A DC rating: 4 A up to 35 VDC, 1 A up to 60 VDC 7) A. o. to communicate with a Lithium-Ion battery BMS 8) The auxiliary output of an early production batch of this product was rated at 35A instead of 50A. This batch has serial numbers starting with HQ2107. Later batches, with 50A aux. output have serial numbers starting with HQ2114 or higher.		



Current sensor 100A:50mA

To implement PowerControl and PowerAssist and to optimize self-consumption with external current sensing.
Maximum current: 50A resp. 100A.



Digital Multi Control Panel

A convenient and low-cost solution for remote monitoring, with a rotary knob to set PowerControl and PowerAssist levels.

Two AC inputs with integrated transfer switch

The Quattro can be connected to two independent AC sources, for example the public grid and a generator, or two generators. The Quattro will automatically connect to the active source.

Two AC Outputs

The main output has no-break functionality. The Quattro takes over the supply to the connected loads in the event of a grid failure or when shore/generator power is disconnected. This happens so fast (less than 20 milliseconds) that computers and other electronic equipment will continue to operate without disruption.

The second output is live only when AC is available on one of the inputs of the Quattro. Loads that should not discharge the battery, like a water heater for example, can be connected to this output.

Split phase and three phase capability

Two units can be configured for split phase, and three units can be configured for three phase output. But that's not all: up to 4 sets of three units can be parallel connected to provide 96W / 120kVA inverter power and more than 1600A charging capacity. For more detail please enter *parallel* in the search box on our website.

PowerControl – Dealing with limited generator, shore side or grid power

A current limit can be set on each AC input. The Quattro will then take account of other AC loads and use whatever is spare for charging, thus preventing the generator or mains supply from being overloaded.

PowerAssist – Boosting shore or generator power

This feature takes the principle of PowerControl to a further dimension allowing the Quattro to supplement the capacity of the alternative source. Where peak power is so often required only for a limited period, the Quattro will make sure that insufficient mains or generator power is immediately compensated for by power from the battery. When the load reduces, the spare power is used to recharge the battery.

Solar energy: AC power available even during a grid failure

The Quattro can be used in off grid as well as grid connected PV and other alternative energy systems. Loss of mains detection software is available.

System configuring

- In case of a stand-alone application, if settings have to be changed, this can be done in a matter of minutes with a DIP switch setting procedure.
- Parallel and three phase applications can be configured with VE.Bus Quick Configure and VE.Bus System Configurator software.
- Off grid, grid interactive and self-consumption applications, involving grid-tie inverters and/or MPPT Solar Chargers can be configured with Assistants (dedicated software for specific applications).

On-site Monitoring and control

Several options are available: Battery Monitor, Multi Control Panel, Color Control GX or other GX devices, smartphone or tablet (Bluetooth Smart), laptop or computer (USB or RS232).

Remote Monitoring and control

Color Control GX or other GX devices.

Data can be stored and displayed on our VRM (Victron Remote Management) website, free of charge.

Remote configuring

When connected to the Ethernet, systems with a Color Control GX or other GX device can be accessed, and settings can be changed remotely.



Quattro
48/5000/70-100/100



Color Control GX, showing a PV application

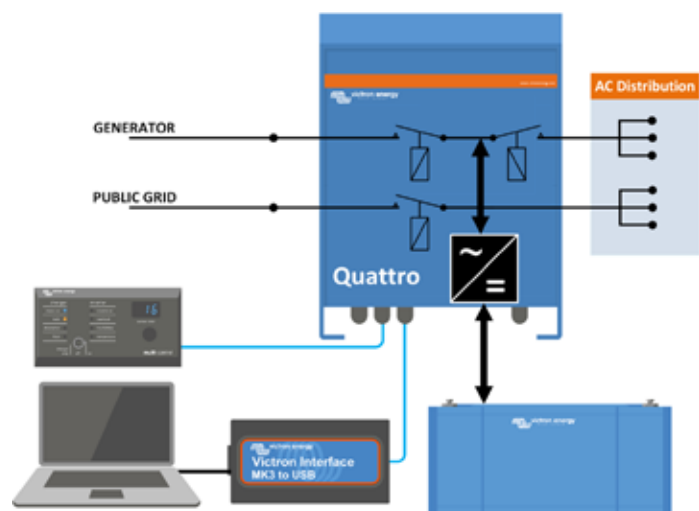

Quattro	48/3000/35-50/50 120V	12/5000/220-100/100 120V 24/5000/120-100/100 120V 48/5000/70-100/100 120V	48/10000/140-100/100 120V
PowerControl / PowerAssist	Yes		
Integrated Transfer switch	Yes		
AC inputs (2x)	Input voltage range: 90-140 VAC Input frequency: 45 – 65 Hz Power factor: 1		
Maximum feed through current	2x 50 A	2x 100 A	2x 100 A
INVERTER			
Input voltage range	9,5 – 17 V 19 – 33V 38 – 66 V		
Output (1)	Output voltage: 120 VAC ± 2% Frequency: 60 Hz ± 0,1%		
Cont. output power at 25°C (3)	3000 VA	5000 VA	10000 VA
Cont. output power at 25°C	2400 W	4000 W	8000 W
Cont. output power at 40°C	2200 W	3700 W	6500 W
Cont. output power at 65°C	1700 W	3000 W	4500 W
Peak power	6000 W	10000 W	20000 W
Maximum efficiency	94 %	94 / 94 / 95 %	96 %
Zero load power	25 W	30 / 30 / 35 W	60 W
Zero load power in AES mode	20 W	20 / 25 / 30 W	40 W
Zero load power in Search mode	12 W	10 / 10 / 15 W	15 W
CHARGER			
Charge voltage 'absorption' (V DC)	57,6 V	14,4 / 28,8 / 57,6 V	57,6 V
Charge voltage 'float' (V DC)	55,2 V	13,8 / 27,6 / 55,2 V	55,2 V
Storage mode (V DC)	52,8 V	13,2 / 26,4 / 52,8 V	52,8 V
Charge current house battery (A) (4)	35 A	200 / 120 / 70 A	140 A
Charge current starter battery (A)	4 A (12V and 24V models only)		
Battery temperature sensor	Yes		
GENERAL			
Auxiliary output (5)	32 A	50 A	50 A
Programmable relay (6)	3x		
Protection (2)	a-g		
VE.Bus communication port	For parallel, split phase and three phase operation, remote monitoring and system integration		
General purpose com. port	2x		
Remote on-off	Yes		
Common Characteristics	Operating temp.: -40 to +65°C Humidity (non-condensing): max. 95%		
ENCLOSURE			
Common Characteristics	Material & Colour: aluminium (blue RAL 5012) Protection category: IP 21		
Battery-connection	Four M8 bolts (2 plus and 2 minus connections)		
120 V AC-connection	Screw terminals 13 mm ² (6 AWG)	Bolts M6	Bolts M6
Weight (kg)	42 lb 19 kg	75 / 66 / 66 lb 34 / 30 / 30 kg	128 lb 58 kg
Dimensions (hwxwd)	14,3 x 10,2 x 8,6 inch 362 x 258 x 218 mm	18,5 x 14,0 x 11,2 inch	470 x 350 x 280 mm
		17,5 x 13,0 x 9,6 inch	444 x 328 x 240 mm
		17,5 x 13,0 x 9,6 inch	444 x 328 x 240 mm
STANDARDS			
Safety	EN-IEC 60335-1, EN-IEC 60335-2-29, EN-IEC 62109-1		
Emission, Immunity	EN 55014-1, EN 55014-2, EN-IEC 61000-3-2, EN-IEC 61000-3-3, IEC 61000-6-1, IEC 61000-6-2, IEC 61000-6-3		
Road vehicles	12V and 24V models: ECE R10-5		
Anti-islanding	See our website		
1) Can be adjusted to 60 HZ; 120 V 60 Hz on request 2) Protection key: a) output short circuit b) overload c) battery voltage too high d) battery voltage too low e) temperature too high f) 120 VAC on inverter output g) input voltage ripple too high		3) Non-linear load, crest factor 3:1 4) Up to 25°C ambient 5) Switches off when no external AC source available 6) Programmable relay that can a.o. be set for general alarm, DC under voltage or genset start/stop function AC rating: 230 V / 4 A DC rating: 4 A up to 35 VDC, 1 A up to 60 VDC	



Digital Multi Control Panel

A convenient and low cost solution for remote monitoring, with a rotary knob to set PowerControl and PowerAssist levels.



VE.Bus Smart Dongle

Measures battery voltage and temperature and allows monitoring and control of Multis and Quattros with a smartphone or other Bluetooth enabled device.



Computer controlled operation and monitoring

Several interfaces are available:



Color Control GX and other GX devices

Monitoring and control. Locally, and also remotely on the [VRM Portal](#).



MK3-USB VE.Bus to USB interface

Connects to a USB port ([see 'A guide to VEConfigure'](#))



VE.Bus to NMEA 2000 interface

Connects the device to a NMEA2000 marine electronics network. See the [NMEA2000 & MFD integration guide](#)



BMV-712 Smart Battery Monitor

Use a smartphone or other Bluetooth enabled device to:

- customize settings,
- monitor all important data on single screen,
- view historical data, and to update the software when new features become available.

Cerbo GX & GX Touch



Cerbo GX

Cerbo GX: communication-centre

This communication-centre allows you to always have perfect control over your system from wherever you are and to maximise its performance. Simply access your system via our Victron Remote Management (VRM) portal, or access it directly, using the optional GX Touch screen, a Multi-Functional Display (MFD) or our VictronConnect app thanks to its Bluetooth capability.

GX Touch: display accessory

The GX Touch 50 and GX Touch 70 are display accessories for the Cerbo GX. The five inch and seven inch touch screen displays give an instant overview of your system and allows you to adjust settings. Simply connect the display to the Cerbo GX with just one cable. Both GX Touch displays have a waterproof design, a top-mountable setup and are simple to install.

Remote Console on VRM

Monitor, control and configure the Cerbo GX remotely, over the internet. Just like if you were standing in front of the device, using Remote Console. The same functionality is also available on the local network LAN, or using the WiFi Access Point of the Cerbo GX.

Perfect monitoring & control

Instantly monitor the battery state of charge, power consumption, power harvest from PV, generator, and mains, or check tank levels and temperature measurements. Easily control the shore power input current limit, (auto)start/stop generator(s) or change any setting to optimise the system. Follow up on alerts, perform diagnostic checks and resolve complications remotely.

Simple mounting and configuration

The Cerbo GX is easily mountable and can also be mounted on a DIN-Rail using the DIN35 adapter small, (not included). Its separate touchscreen can be bolted on a dashboard, eliminating the need to create perfect cut-outs (like with the Color Control GX). Connection is easy via just one cable, taking away the hassle of having to bring many wires to the dashboard. The Bluetooth feature enables a quick connection and configuration via our VictronConnect app.



Accessories included with the Cerbo GX



GX Touch (optional display for Cerbo GX)

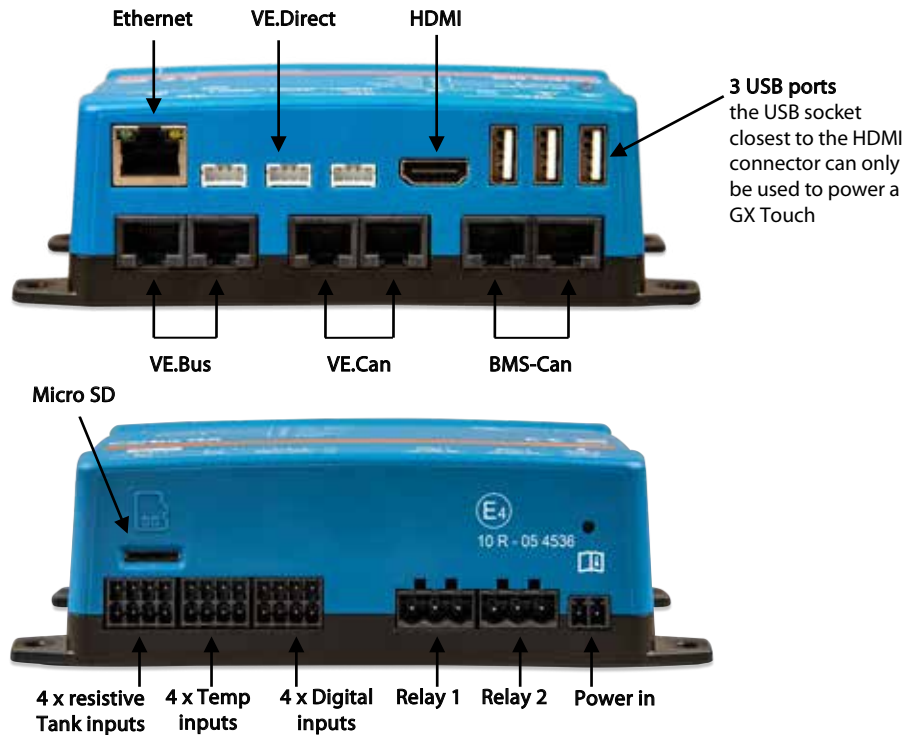

WiFi indicator LED

The Cerbo GX can connect to a WiFi Network

Bluetooth indicator LED

The Cerbo GX can be accessed directly via Bluetooth using the VictronConnect app



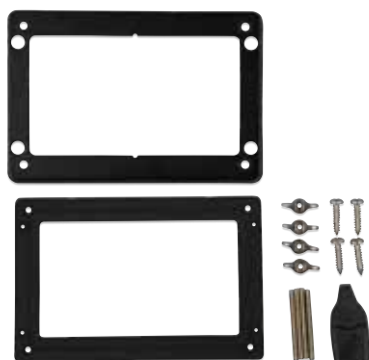

Accessories included with the GX Touch

Optional accessories



GX Touch adapter for CCGX cut-out

This adapter is designed to easily replace the CCGX display with the newer GX Touch 50 or the GX Touch 70. Contents of the packaging are the metal bracket, the plastic bezel, and four mounting screws.



Temperature sensor for Quattro, MultiPlus and GX Device (such as the Cerbo GX)



DIN35 adapter small

DIN-Rail adapter to easily mount a device on a DIN-Rail. Suitable for the Cerbo GX.

	Cerbo GX	Cerbo 3 GX
Supply voltage	8 – 70V DC	
Mounting	Wall or DIN rail (35mm) ⁽²⁾	
Communication ports		
VE.Direct ports (always isolated)	3 ⁽³⁾	
VE.Bus (always isolated)	2 paralleled RJ45 sockets	
VE.Can	yes - non isolated	
BMS-Can port	yes	No
IO		
Resistive tank level inputs	4	0
Temperature sense inputs	4	0
Digital Inputs	4	4
Other		
Outer dimensions (h x w x d)	78 x 154 x 48 mm	
Operating temperature range	-20 to +50°C	
Standards		
Safety	IEC 62368-1	
EMC	EN 301489-1, EN 301489-17	
Automotive	ECE R10-6	
GX Touch 50 / GX Touch 70		
Mounting	With included mounting accessories	
Display Resolution	GX Touch 50: 800 x 480 GX Touch 70: 1024 x 600	
Other		
Outer dimensions (h x w x d)	GX Touch 50: 87 x 128 x 12.4 mm GX Touch 70: 113 x 176 x 13.5 mm	
Cable length	2 meter	
Notes		
1. For more detailed information about the Cerbo GX and the GX Touch, please visit the Victron GX product range page at Victron live: www.victronenergy.com/live/venus-os:start		
2. DIN rail mounting requires additional accessory - DIN35 Adapter.		
3. The listed maximum on the `Performance` section in above table is the total connected VE.Direct devices such as MPPT Solar Charge controllers. Total means all directly connected devices plus the devices connected over USB. The limit is mostly bound by CPU processing power. Note that there is also a limit to the other type of devices of which often multiple are connected: PV Inverters. Up to three or four three phase inverters can typically be monitored on a CCGX. Higher power CPU devices can monitor more.		

Color Control GX



Color Control GX

The Color Control (CCGX) provides intuitive control and monitoring for all Victron power systems. The list of Victron products that can be connected is endless: Inverters, Multis, Quattros, MPPT solar chargers, BMV battery monitors, Lynx Ion + Shunt and more.

VRM Online Portal

Besides monitoring and controlling products locally on the CCGX itself, all readings are also forwarded to our free remote monitoring website: the VRM Online Portal. To get an impression, try the demo on <https://vrm.victronenergy.com>. See also the screenshots below.

Remote Console on VRM

Monitor, control and configure the CCGX remotely, over the internet. Just like standing in front of the device, everything can also be done remotely. The same functionality is also available on the local network, Remote Console on LAN.

Automatic genset start/stop

A highly customizable start/stop system. Use state of charge, voltage, load and other parameters. Define a special set of rules for quiet times, and optionally a monthly test run.

The heart of ESS – Energy Storage System

The CCGX is the Energy Manager in an ESS system. More information in the ESS manual: <https://www.victronenergy.com/live/ess:design-installation-manual>

Data logging

When connected to the internet, all data is sent to the VRM Portal. When there is no internet connection available, the CCGX will store the data internally, up to 48 hours. By inserting a micro SD-card or USB stick, more data can be stored. These files can then be uploaded to the VRM Portal, or offline converted with the VictronConnect app, for analysis.

Supported products

- Multis and Quattros, including split-phase and three-phase systems. Monitoring and control (on/off and current limiter). Changing configuration is possible (only remotely via the internet, not without an internet connection).
- BlueSolar MPPT Solar Chargers with a VE.Direct port.
- BlueSolar MPPT 150/70 and the MPPT 150/85 with VE.Can port.
- SmartSolar MPPT 150/70 and the MPPT 150/100 with VE.Can port. When multiple BlueSolar MPPTs or SmartSolar MPPTs with VE.Can are used in parallel, all the information is combined as one. See also our blog-post about [synchronizing multiple MPPT 150/70 solar chargers](#).
- BMV-700 family can be connected directly to the VE.Direct ports on the CCGX. Use the VE.Direct Cable for this.
- BMV-600 family can be connected to the VE.Direct ports on the CCGX. Requires an accessory cable.
- Lynx Ion + Shunt
- Lynx Shunt VE.Can
- Skylla-i battery chargers
- NMEA2000 tank sensors
- A USB GPS can be connected to the USB port. Location and speed will be visible on the display, and the data is sent to the VRM Portal for tracking purposes. The map on VRM will show the latest position.
- Fronius PV Inverters

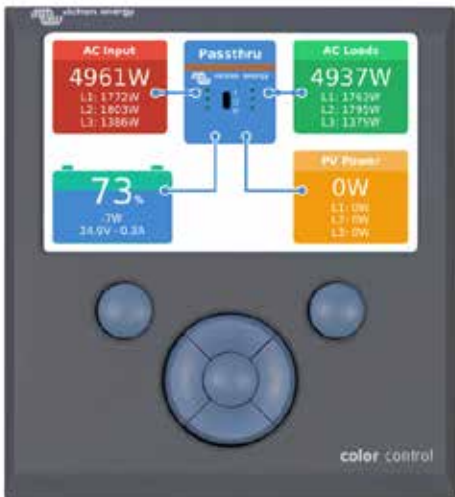

When more than two VE.Direct products must be connected, USB can be used.

Internet connection

The CCGX can be connected to internet with an Ethernet cable and via wifi. To connect via wifi, a wifi USB accessory is required. The CCGX has no internal cellular modem: there is no slot for a sim-card. Use an off-the-shelf GPRS or 3G router instead. See the [blog post about 3G routers](#).

Other highlights

- The CCGX can automatically update itself from the internet, when there is a new software version available.
- Multiple languages: English, Czech, German, Spanish, French, Italian, Dutch, Russian, Swedish, Turkish, Chinese, Arabic.
- Use the CCGX as a Modbus-TCP gateway to all connected Victron products. See our [Modbus-TCP FAQ](#) for more information.
- Powered by the Venus OS – embedded linux.
<https://github.com/victronenergy/venus/wiki/sales-pitch>



Color Control GX			
Power supply voltage range	8 – 70V DC		
Current draw	12V DC	24V DC	48V DC
Display off	140mA	80mA	40mA
Display at minimum intensity	160mA	90mA	45mA
Display at maximum intensity	245mA	125mA	65mA
Potential free contact	3A / 30V DC / 250V AC (Normally open)		
Communication ports			
VE.Direct	2 separate VE.Direct ports – isolated		
VE.Can	2 paralleled RJ45 sockets – isolated		
VE.Bus	2 paralleled RJ45 sockets – isolated		
USB	2 USB Host ports – not isolated		
Ethernet	10/100/1000MB RJ45 socket – isolated except shield		
3rd party interfacing			
Modbus-TCP	Use Modbus-TCP to monitor and control all products connected to the Color Control GX		
JSON	Use the VRM JSON API to retrieve data from the VRM Portal		
Other			
Outer dimensions (h x w x d)	130 x 120 x 28mm		
Operating temperature range	-20 to +50°C		
Standards			
Safety	EN 60950-1:2005+A1:2009+A2:2013		
EMC	EN 61000-6-3, EN 55014-1, EN 61000-6-2, EN 61000-6-1, EN 55014-2		
Automotive	E4-10R-053535		

Overview - Multi with PV Inverter on output



Mobile & boat overview

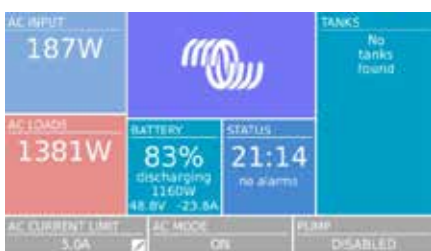

Genset control page



Main menu



Alarm notifications

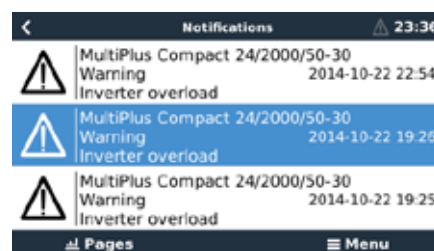

Tiles overview



VRM Portal - Dashboard

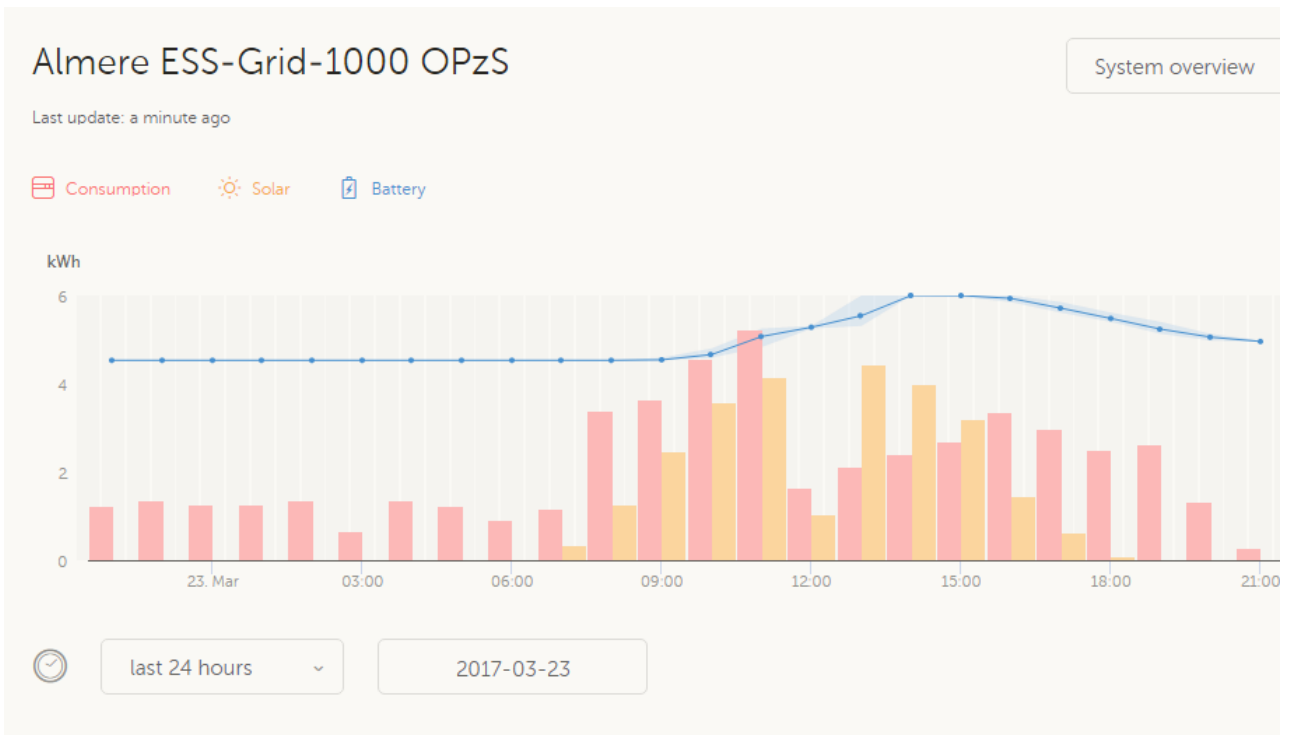

VRM Portal – Remote Console

Almere ESS-Grid-1000 OPzS

Last update: a few seconds ago

Consumption Solar Battery

kWh

Device List		21:18
Fronius Symo 8.2-3-M	0W	>
Grid meter	216W	>
MultiPlus 48/5000/70-50	Bulk	>
PV Inverter on input 1	0W	>
Notifications		>
Settings		>

Pages Menu

Almere ESS-Grid-1000 OPzS Remote Console

Realtime data

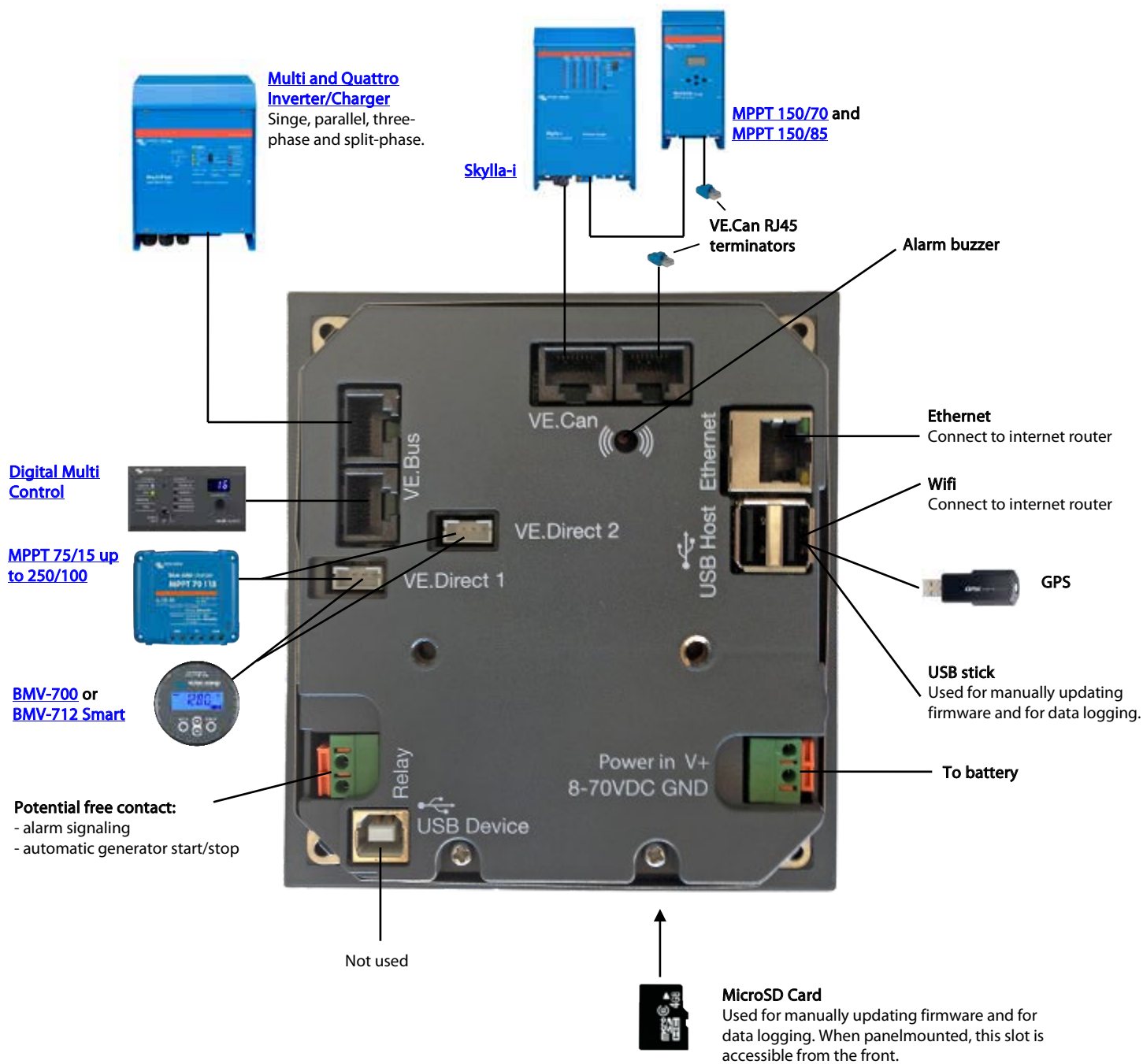

BMV-712 Smart: Bluetooth inside



BMV-712 Smart



BMV bezel square



BMV shunt 500A/50mV
With quick connect pcb



See the VictronConnect BMV app Discovery Sheet for more screenshots

Bluetooth inside

With Bluetooth built-in, the BMV Smart is ready for the Internet of Things (IoT) era. With Bluetooth being implemented in most other Victron Energy products, wireless communication between products will simplify system installation and enhance performance.

Download the Victron Bluetooth app

Use a smartphone or other Bluetooth enabled device to

- customize settings,
- monitor all important data on single screen,
- view historical data, and to
- update the software when new features become available.

Easy to install

All electrical connections are to the quick connect PCB on the current shunt. The shunt connects to the monitor with a standard RJ12 telephone cable. Included: RJ12 cable (10 m) and battery cable with fuse (2 m); no other components needed.

Also included are a separate front bezel for a square or round display appearance, a securing ring for rear mounting and screws for front mounting.

Midpoint voltage monitoring

One bad cell or one bad battery can destroy a large, expensive battery bank. When batteries are connected in series, a timely warning can be generated by measuring the midpoint voltage. Please see the BMV manual, section 5.2, for more information.

We recommend our **Battery Balancer** (BMS012201000) to maximize service life of series-connected lead-acid batteries.

Very low current draw from the battery

Current consumption: 0.7 Ah per month (1 mA) @12 V and 0.6 Ah per month (0.8 mA) @ 24 V

Especially Li-ion batteries have virtually no capacity left when discharged until low voltage shutdown.

After shutdown due to low cell voltage, the capacity reserve of a Li-ion battery is approximately 1Ah per 100 Ah battery capacity. The battery will be damaged if the remaining capacity reserve is drawn from the battery. A residual current of 10 mA for example may damage a 200 Ah battery if the system is left in discharged state during more than 8 days.

Bi-stable alarm relay

Prevents increased current draw in case of an alarm.

Other features

- Battery voltage, current, power, ampere-hours consumed and state of charge
- Remaining time at the current rate of discharge
- Programmable visual and audible alarm
- Programmable relay, to turn off non critical loads or to run a generator when needed
- 500 Amp quick connect shunt and connection kit
- Shunt selection capability up to 10,000 Amps
- VE.Direct communication port
- Stores a wide range of historical events, which can be used to evaluate usage patterns and battery health
- Wide input voltage range: 6.5 – 70 V
- High current measurement resolution: 10 mA (0.01 A)
- Additional input to measure voltage (of a second battery), temperature or midpoint voltage, and corresponding alarm and relay settings

Battery Monitor	BMV-712 Smart
Supply voltage range	6.5 - 70 VDC
Current draw, back light off	< 1 mA
Input voltage range, auxiliary battery	6.5 - 70 VDC
Battery capacity (Ah)	1 - 9999 Ah
Operating temperature range	-40 +50 °C (-40 - 120 °F)
Measures voltage of second battery, or temperature, or midpoint	Yes
Temperature measurement range	-20 +50 °C
VE.Direct communication port	Yes
Bistable relay	60V / 1A normally open (function can be inverted)
RESOLUTION & ACCURACY (with a 500 A shunt)	
Current	± 0.01 A
Voltage	± 0.01 V
Amp hours	± 0.1 Ah
State of charge (0 - 100%)	± 0.1 %
Time to go	± 1 min
Temperature (0 - 50°C or 30 - 120°F)	± 1 °C/°F
Accuracy of current measurement	± 0.4 %
Accuracy of voltage measurement	± 0.3 %
INSTALLATION & DIMENSIONS	
Installation	Flush mount
Front	63mm diameter
Front bezel	69 x 69mm (2.7 x 2.7 inch)
Shunt connections bolts	M10 (0.3937 inch)
Body diameter and depth	52 mm (2.0 inch) and 31 mm (1.2 inch)
Protection category	IP55 (not intended for outdoor use)
STANDARDS	
Safety	EN 60335-1
Emission / Immunity	EN 55014-1 / EN 55014-2
Automotive	ECE R10-4 / EN 50498
ACCESSORIES	
Shunt (included)	500 A / 50 mV
Cables (included)	10 meter 6 core UTP with RJ12 connectors, and cable with 1Amp slow blow fuse for '+' connection
Temperature sensor	Optional (ASS000100000)
STORED TRENDS	
Data stored	Battery voltage, Current, State of Charge % as well as the Aux input (Battery temperature, or midpoint deviation, or starter battery voltage).
Number of days trends data is stored	46



1000A/50 mV, 2000 A/50 mV and 6000 A/50 mV shunt
The quick connect PCB on the standard 500 A/50 mV shunt can also be mounted on these shunts.



Interface cables
- VE.Direct cables to connect a BMV 712 to the Color Control (ASS030530xxx)
- VE.Direct to USB interface (ASS030530000) to connect several BMV 70x to a Color Control GX or to a computer.



Temperature sensor

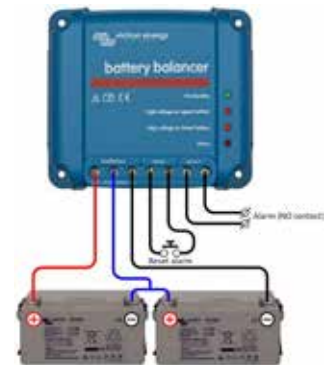

Battery Balancer (BMS012201000)
The Battery Balancer equalizes the state of charge of two series connected 12V batteries, or of several parallel strings of series connected batteries.
When the charge voltage of a 24 V battery system increases to more than 27 V, the Battery Balancer will turn on and compare the voltage over the two series connected batteries. The Battery Balancer will draw a current of up to 1A from the battery (or parallel connected batteries) with the highest voltage. The resulting charge current differential will ensure that all batteries will converge to the same state of charge.

If needed, several balancers can be paralleled.

A 48 V battery bank can be balanced with three Battery Balancers.



Color Control
The powerful Linux computer, hidden behind the colour display and buttons, collects data from all Victron equipment and shows it on the display. Besides communicating with Victron equipment, the Color Control communicates through CAN bus (NMEA 2000), Ethernet and USB. Data can be stored and analysed on the VRM Portal.



A maximum of four BMVs can be connected directly to a Color Control GX. Even more BMVs can be connected to a USB Hub for central monitoring.



Venus GX
The Venus GX provides intuitive control and monitoring. It has the same functionality as the Color Control GX, with a few extras:
- lower cost, mainly because it has no display or buttons
- 3 tank sender inputs
- 2 temperature inputs



SmartShunt 500 A



SmartShunt 1000 A



SmartShunt 2000 A



The SmartShunt is an all in one battery monitor, only without a display. Your phone acts as the display.

The SmartShunt connects via Bluetooth to the VictronConnect App on your phone (or tablet) and you can conveniently read out all monitored battery parameters, like state of charge, time to go, historical information and much more.

Alternatively, the SmartShunt can be connected and be read by a GX device. Connection to the SmartShunt is made via a VE.Direct cable.

The SmartShunt is a good alternative for a BMV battery monitor, especially for systems where battery monitoring is needed but less wiring and clutter is wanted.

The SmartShunt is equipped with Bluetooth, a VE.Direct port and a connection that can be used to monitor a second battery, for midpoint monitoring, or to connect a temperature sensor.

Differences compared to BMV-712 Battery Monitor

- No programmable visual and audible alarm.
- No programmable relay.

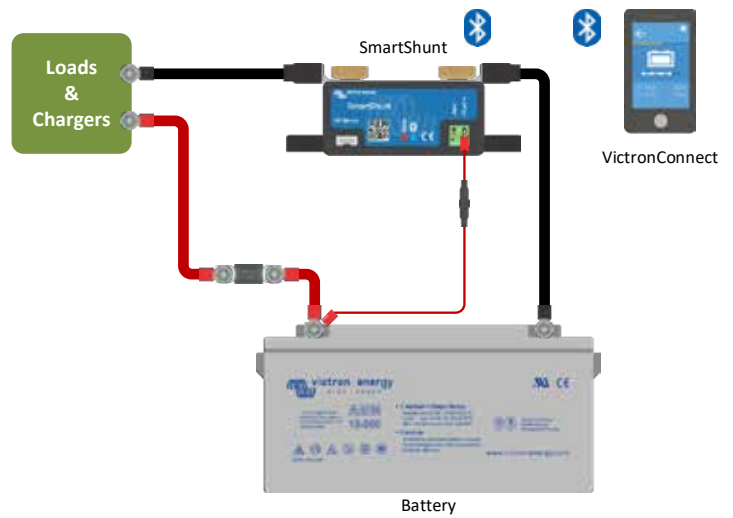

Basic SmartShunt wiring

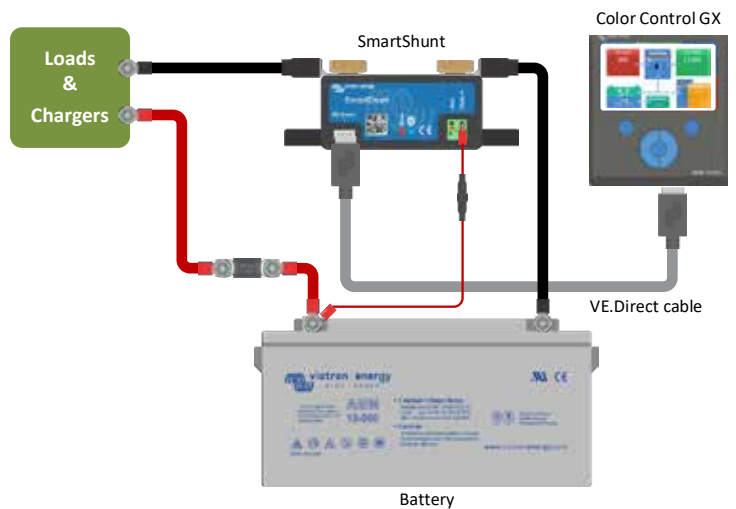

Connecting a SmartShunt to a GX device

SmartShunt	500A / 1000A / 2000A
Supply voltage range	6.5 - 70 VDC
Current draw	< 1mA
Input voltage range, auxiliary battery	6.5 - 70 VDC
Battery capacity (Ah)	1 - 9999 Ah
Operating temperature range	-40 +50°C (-40 - 120°F)
Measures voltage of second battery, or temperature, or midpoint	Yes
Temperature measurement range	-20 +50°C
VE.Direct communication port	Yes
RESOLUTION & ACCURACY	
Current	± 0.01 A
Voltage	± 0.01 V
Amp hours	± 0.1 Ah
State of charge (0 – 100 %)	± 0.1 %
Time to go	± 1 min
Temperature (if optional temperature sensor connected)	± 1 °C/°F (0 – 50 °C or 30 – 120 °F)
Accuracy of current measurement	± 0.4 %
Offset	Less than 20 / 40 / 80 mA
Accuracy of voltage measurement	± 0.3 %
INSTALLATION & DIMENSIONS	
Dimensions (h x w x d)	500 A: 46 x 120 x 54 mm 1000 A: 68 x 168 x 75 mm 2000 A: 68 x 168 x 100 mm
Shunt connection bolts	M10 (0.3937 inch)
Protection category	IP21
STANDARDS	
Safety	EN 60335-1
Emission / Immunity	EN-IEC 61000-6-1 EN-IEC 61000-6-2 EN-IEC 61000-6-3
Automotive	EN 50498
ACCESSORIES	
Cables (included)	Two cables with 1 A fuse, for '+' connection and starter battery or midpoint connection
Temperature sensor	Optional (ASS000100000)
A note regarding the range of the Bluetooth signal	The shunt and the electric cables do negatively influence the range of the Bluetooth signal. The resulting range of 10-15 meter is however satisfactory in most cases. The proximity of other electrically conducting elements, such as the metal chassis of a vehicle or seawater around the hull if a boat, may reduce the range of the Bluetooth signal to an unacceptable level. The solution in such a case is to add a VE.Direct Bluetooth Dongle (ASS030536011) to the system, and to switch off Bluetooth in the SmartShunt.
STORED TRENDS	
Data stored	Battery voltage, Current, State of Charge % as well as the Aux input (Battery temperature, or midpoint deviation, or starter battery voltage).
Number of days trends data is stored	46

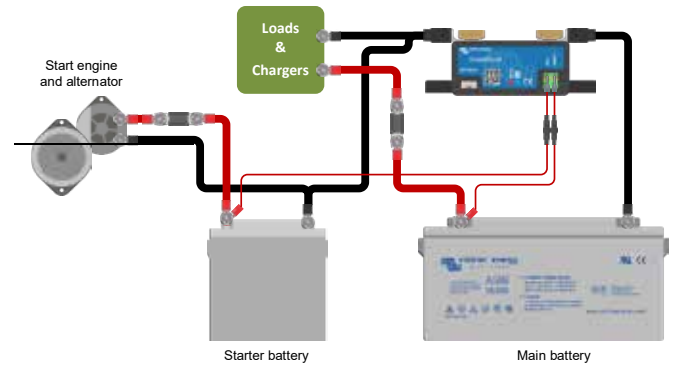

Measuring voltage of the starter battery

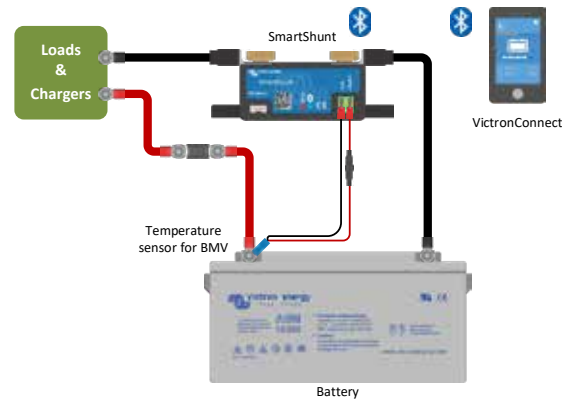

Measuring battery temperature

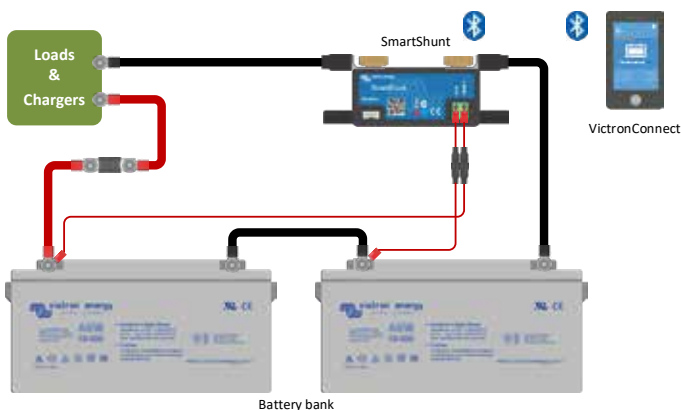

Measuring battery bank midpoint

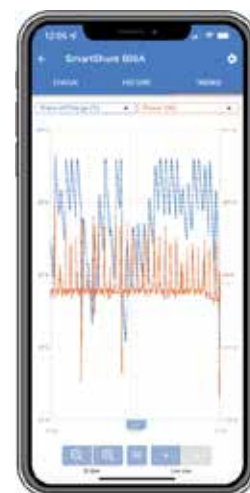

Stored trends for SmartShunt

The SmartShunt IP65 is an all-in-one battery monitor, only without a display. Your phone acts as the display.

The SmartShunt IP65 is water resistant and is available in a 500 A, 1000 A or 2000 A version.

The SmartShunt IP65 connects via Bluetooth to the VictronConnect app on your phone (or tablet) and you can conveniently read out all monitored battery parameters, like state of charge, time to go, historical information and much more.

Alternatively, the SmartShunt IP65 can be connected and be read by a GX device. Connection to the SmartShunt is made via a VE.Direct cable.

The SmartShunt is a good alternative for a BMV battery monitor, especially for systems where battery monitoring is needed but less wiring and clutter is wanted.

The SmartShunt is equipped with Bluetooth, has a VE.Direct port and an auxiliary connection that can be used to monitor a second battery, for midpoint monitoring, or to connect a temperature sensor.



SmartShunt IP65 500 A



SmartShunt IP65 1000 A



SmartShunt IP65 2000 A

Differences compared to BMV-712 Battery Monitor

- No visual and audible alarm (alarms are only visible via the VictronConnect app or GX device).
- No programmable relay.
- Waterproof.
- The shunt is attached to the battery monitor unit.

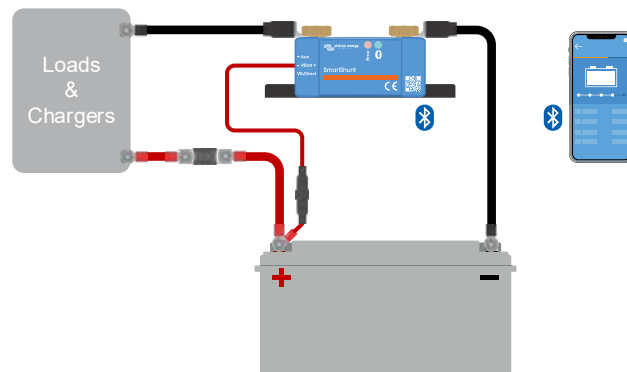

Basic SmartShunt wiring

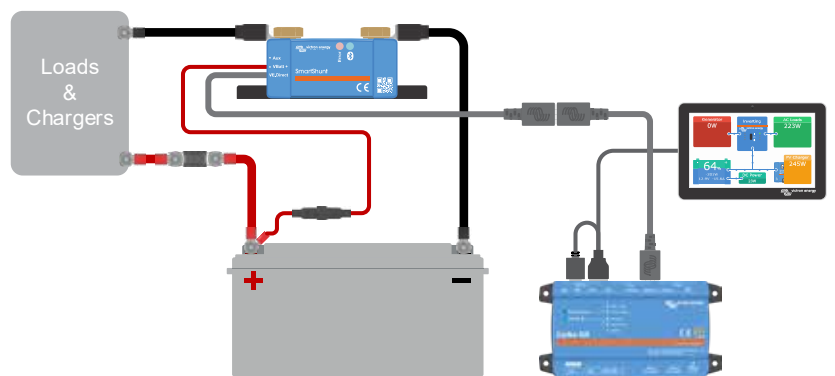

Connecting a SmartShunt to a GX device

SmartShunt IP65	500 A / 1000 A / 2000 A
Supply voltage range	6.5 - 70 VDC
Current draw	< 1 mA
Input voltage range, auxiliary battery	6.5 - 70 VDC
Battery capacity (Ah)	1 - 9999 Ah
Operating temperature range	-40 +50 °C (-40 - 120 °F)
Measures voltage of second battery, or temperature, or midpoint	Yes
Temperature measurement range	-20 +50 °C
VE.Direct communication port	Yes
RESOLUTION & ACCURACY	
Current	± 0.01 A
Voltage	± 0.01 V
Amp hours	± 0.1 Ah
State of charge (0 - 100 %)	± 0.1 %
Time to go	± 1 min
Temperature (if optional temperature sensor connected)	± 1 °C/°F (0 - 50 °C or 30 - 120 °F)
Accuracy of current measurement	± 0.4 %
Offset	Less than 20 / 40 / 80 mA
Accuracy of voltage measurement	± 0.3 %
INSTALLATION & DIMENSIONS	
Dimensions (h x w x d)	500A: 46 x 120 x 54 mm 1000A: 68 x 168 x 75 mm 2000A: 68 x 168 x 100 mm
Shunt connection bolts	M10 (0.3937 inch)
Protection category	IP65
STANDARDS	
Safety	EN 60335-1
Emission / Immunity	EN-IEC 61000-6-1 EN-IEC 61000-6-2 EN-IEC 61000-6-3
Automotive	EN 50498
Cables	Two 1.5 m cables with 1 A fuse, for '+' connection and starter battery or midpoint connection
VE.Direct cable	1.5 m cable with a VE.Direct socket. Note that a (not included) VE.Direct cable is needed to connect a GX device.
Temperature sensor	Optional (ASS000100000)
A note regarding the range of the Bluetooth signal	The shunt and the electric cables do negatively influence the range of the Bluetooth signal. The resulting range of 10-15 meter is however satisfactory in most cases. The proximity of other electrically conducting elements, such as the metal chassis of a vehicle or seawater around the hull if a boat, may reduce the range of the Bluetooth signal to an unacceptable level. The solution in such a case is to add a VE.Direct Bluetooth Dongle (ASS030536011) to the system, and to switch off Bluetooth in the SmartShunt.
STORED TRENDS	
Data stored	Battery voltage, Current, State of Charge % as well as the Aux input (Battery temperature, or midpoint deviation, or starter battery voltage).
Number of days trends data is stored	46

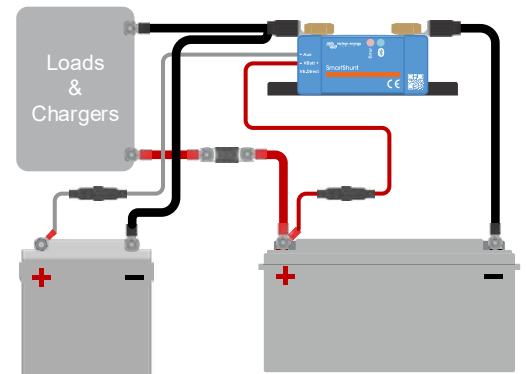

Measuring voltage of the starter battery

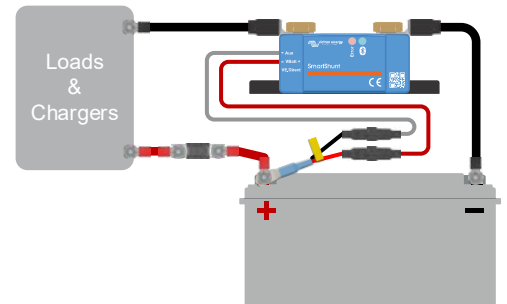

Measuring battery temperature

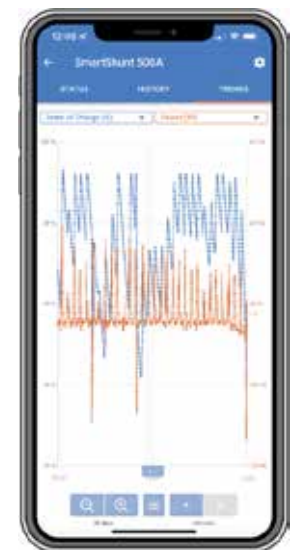

Stored trends for SmartShunt

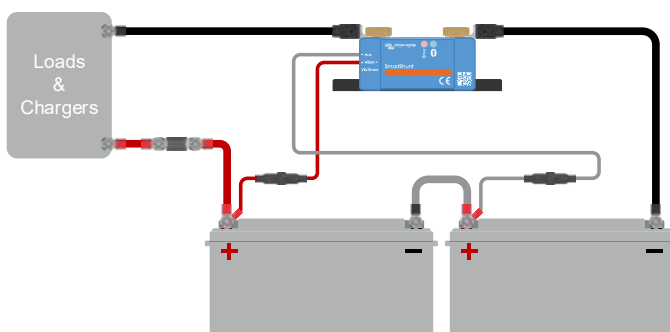

Measuring battery bank midpoint

BlueSolar and SmartSolar MPPT Charge Controllers - Overview

BlueSolar Charge Controller	Load output	Battery voltage	Optional display	Bluetooth	Com. port	Remote on-off	Programmable relay	Wire Box
75/10	15A	12/24V	MPPT control	Optional dongle	VE.Direct	No	No	S 75-10/15
75/15	15A	12/24V	MPPT control	Optional dongle	VE.Direct	No	No	S 75-10/15
100/15	15A	12/24V	MPPT control	Optional dongle	VE.Direct	No	No	S 100-15
100/20 (up to 48V)	20A/20A/1A	12/24/36/48V	MPPT control	Optional dongle	VE.Direct	No	No	S 100-20
100/30	No	12/24V	MPPT control	Optional dongle	VE.Direct	No	No	M
100/50	No	12/24V	MPPT control	Optional dongle	VE.Direct	No	No	M
150/35	No	12/24/36/48V	MPPT control	Optional dongle	VE.Direct	No	No	M
150/45	No	12/24/36/48V	MPPT control	Optional dongle	VE.Direct	No	No	M
150/45-Tr	No	12/24/36/48V	MPPT control	Optional dongle	VE.Direct	No	No	L
150/45-MC4	No	12/24/36/48V	MPPT control	Optional dongle	VE.Direct	No	No	L
150/60-Tr	No	12/24/36/48V	MPPT control	Optional dongle	VE.Direct	No	No	L
150/60-MC4	No	12/24/36/48V	MPPT control	Optional dongle	VE.Direct	No	No	L
150/70-Tr	No	12/24/36/48V	MPPT control	Optional dongle	VE.Direct	No	No	L
150/70-MC4	No	12/24/36/48V	MPPT control	Optional dongle	VE.Direct	No	No	L
150/100-Tr VE.Can	No	12/24/36/48V	MPPT ctrl & SmartSolar ctrl	Optional dongle	VE.Direct & VE.Can	Yes	Yes	XL
250/70-Tr VE.Can	No	12/24/36/48V	MPPT ctrl & SmartSolar ctrl	Optional dongle	VE.Direct & VE.Can	Yes	Yes	L
250/100-Tr VE.Can	No	12/24/36/48V	MPPT ctrl & SmartSolar ctrl	Optional dongle	VE.Direct & VE.Can	Yes	Yes	XL
SmartSolar Charge Controller	Load output	Battery voltage	Optional display	Bluetooth	Com. port	Remote on-off	Programmable relay	Wire Box
75/10	15A	12/24V	MPPT control	Built-in	VE.Direct	No	No	S 75-10/15
75/15	15A	12/24V	MPPT control	Built-in	VE.Direct	No	No	S 75-10/15
100/15	15A	12/24V	MPPT control	Built-in	VE.Direct	No	No	S 100-15
100/20 (up to 48V)	20A/20A/1A	12/24/36/48V	MPPT control	Built-in	VE.Direct	No	No	S 100-20
100/30	No	12/24V	MPPT control	Built-in	VE.Direct	No	No	M
100/50	No	12/24V	MPPT control	Built-in	VE.Direct	No	No	M
150/35	No	12/24/36/48V	MPPT control	Built-in	VE.Direct	No	No	M
150/45	No	12/24/36/48V	MPPT control	Built-in	VE.Direct	No	No	M
150/45-Tr	No	12/24/36/48V	MPPT ctrl & SmartSolar ctrl	Built-in	VE.Direct	Yes	Yes	L
150/45-MC4	No	12/24/36/48V	MPPT ctrl & SmartSolar ctrl	Built-in	VE.Direct	Yes	Yes	L
150/60-Tr	No	12/24/36/48V	MPPT ctrl & SmartSolar ctrl	Built-in	VE.Direct	Yes	Yes	L
150/60-MC4	No	12/24/36/48V	MPPT ctrl & SmartSolar ctrl	Built-in	VE.Direct	Yes	Yes	L
150/70-Tr	No	12/24/36/48V	MPPT ctrl & SmartSolar ctrl	Built-in	VE.Direct	Yes	Yes	L
150/70-MC4	No	12/24/36/48V	MPPT ctrl & SmartSolar ctrl	Built-in	VE.Direct	Yes	Yes	L
150/70-Tr VE.Can	No	12/24/36/48V	MPPT ctrl & SmartSolar ctrl	Built-in	VE.Direct & VE.Can	Yes	Yes	L
150/70-MC4 VE.Can	No	12/24/36/48V	MPPT ctrl & SmartSolar ctrl	Built-in	VE.Direct & VE.Can	Yes	Yes	L
150/85-Tr VE.Can	No	12/24/36/48V	MPPT ctrl & SmartSolar ctrl	Built-in	VE.Direct & VE.Can	Yes	Yes	XL
150/85-MC4 VE.Can	No	12/24/36/48V	MPPT ctrl & SmartSolar ctrl	Built-in	VE.Direct & VE.Can	Yes	Yes	XL
150/100-Tr VE.Can	No	12/24/36/48V	MPPT ctrl & SmartSolar ctrl	Built-in	VE.Direct & VE.Can	Yes	Yes	XL
150/100-MC4 VE.Can	No	12/24/36/48V	MPPT ctrl & SmartSolar ctrl	Built-in	VE.Direct & VE.Can	Yes	Yes	XL
250/60-Tr	No	12/24/36/48V	MPPT ctrl & SmartSolar ctrl	Built-in	VE.Direct	Yes	Yes	L
250/60-MC4	No	12/24/36/48V	MPPT ctrl & SmartSolar ctrl	Built-in	VE.Direct	Yes	Yes	L
250/70-Tr	No	12/24/36/48V	MPPT ctrl & SmartSolar ctrl	Built-in	VE.Direct	Yes	Yes	L
250/70-MC4	No	12/24/36/48V	MPPT ctrl & SmartSolar ctrl	Built-in	VE.Direct	Yes	Yes	L
250/70-Tr VE.Can	No	12/24/36/48V	MPPT ctrl & SmartSolar ctrl	Built-in	VE.Direct & VE.Can	Yes	Yes	L
250/70-MC4 VE.Can	No	12/24/36/48V	MPPT ctrl & SmartSolar ctrl	Built-in	VE.Direct & VE.Can	Yes	Yes	L
250/85-Tr VE.Can	No	12/24/36/48V	MPPT ctrl & SmartSolar ctrl	Built-in	VE.Direct & VE.Can	Yes	Yes	XL
250/85-MC4 VE.Can	No	12/24/36/48V	MPPT ctrl & SmartSolar ctrl	Built-in	VE.Direct & VE.Can	Yes	Yes	XL
250/100-Tr VE.Can	No	12/24/36/48V	MPPT ctrl & SmartSolar ctrl	Built-in	VE.Direct & VE.Can	Yes	Yes	XL
250/100-MC4 VE.Can	No	12/24/36/48V	MPPT ctrl & SmartSolar ctrl	Built-in	VE.Direct & VE.Can	Yes	Yes	XL



Color Control GX



Venus GX



Cerbo GX



Smart Battery Sense



VE.Direct Bluetooth Smart Dongle



VE.Direct to USB interface

SmartSolar charge controller MPPT 75/10, 75/15, 100/15 & 100/20-48V

SmartSolar Charge Controller
MPPT 75/15Bluetooth sensing
Smart Battery SenseBluetooth sensing
BMV-712 Smart Battery Monitor

Stored trends

Bluetooth Smart built-in

The wireless solution to set-up, monitor, update and synchronise SmartSolar Charge Controllers.

VE.Direct - For a wired data connection to a Color Control GX, other GX products, PC or other devices

Ultra-fast Maximum Power Point Tracking (MPPT)

Especially in case of a clouded sky, when light intensity is changing continuously, an ultra-fast MPPT controller will improve energy harvest by up to 30 % compared to PWM charge controllers and by up to 10 % compared to slower MPPT controllers.

Load output

Over-discharge of the battery can be prevented by connecting all loads to the load output. The load output will disconnect the load when the battery has been discharged to a pre-set voltage (48 V model: interface with a relay).

Alternatively, an intelligent battery management algorithm can be chosen: see Battery Life.

The load output is short circuit proof.

Battery Life: intelligent battery management

When a solar charge controller is not able to recharge the battery to its full capacity within one day, the result is often that the battery will continually be cycled between a 'partially charged' state and the 'end of discharge' state. This mode of operation (no regular full recharge) will destroy a lead-acid battery within weeks or months.

The Battery Life algorithm will monitor the state of charge of the battery and, if needed, day by day slightly increase the load disconnect level (i.e. disconnect the load earlier) until the harvested solar energy is sufficient to recharge the battery to nearly the full 100 %. From that point onwards, the load disconnect level will be modulated so that a nearly 100 % recharge is achieved about once every week.

Programmable battery charge algorithm - See the software section on our website for details

Day/night timing and light dimming option - See the software section on our website for details

Internal temperature sensor - Compensates absorption and float charge voltage for temperature.

Optional external battery voltage and temperature sensing via Bluetooth

A Smart Battery Sense or a BMV-712 Smart Battery Monitor can be used to communicate battery voltage and temperature to one or more SmartSolar Charge Controllers.

Fully discharged battery recovery function

Will initiate charging even if the battery has been discharged to zero volts.

Will reconnect to a fully discharged Li-ion battery with integrated disconnect function.

SmartSolar Charge Controller	MPPT 75/10	MPPT 75/15	MPPT 100/15	MPPT 100/20-48V
Battery voltage (auto select)		12/24 V		12/24/48 V
Rated charge current	10 A	15 A	15 A	20 A
Nominal PV power, 12 V 1a,b)	145 W	220 W	220 W	290 W
Nominal PV power, 24 V 1a,b)	290 W	440 W	440 W	580 W
Nominal PV power, 48 V 1a,b)	n. a.	n. a.	n. a.	1160 W
Max. PV short circuit current 2)	13 A	15 A	15 A	20 A
Automatic load disconnect	Yes			
Max. PV open circuit voltage	75 V		100 V	
Peak efficiency	98 %			
Self-consumption – load on	12 V: 19 mA	24 V: 16 mA	26 / 20 / 19 mA	
Self-consumption – load off	12 V: 10 mA	24 V: 8 mA	10 / 8 / 7 mA	
Charge voltage 'absorption'	14,4 V / 28,8 V (adjustable)			14,4 V / 28,8 V / 57,6 V (adj.)
Charge voltage 'float'	13,8 V / 27,6 V (adjustable)			13,8 V / 27,6 V / 55,2 V (adj.)
Charge algorithm	multi-stage adaptive			
Temperature compensation	-16 mV / °C resp. -32 mV / °C			
Max. continuous load current	15 A			20 A / 20 A / 1 A
Low voltage load disconnect	11,1 V / 22,2 V / 44,4 V or 11,8 V / 23,6 V / 47,2 V or Battery Life algorithm			
Low voltage load reconnect	13,1 V / 26,2 V / 52,4 V or 14 V / 28 V / 56 V or Battery Life algorithm			
Protection	Output short circuit / Over temperature			
Operating temperature	-30 to +60 °C (full rated output up to 40 °C)			
Humidity	95 %, non-condensing			
Data communication port	VE.Direct (see the data communication white paper on our website)			
ENCLOSURE				
Colour	Blue (RAL 5012)			
Power terminals	6 mm ² / AWG10			
Protection category	IP43 (electronic components), IP22 (connection area)			
Weight	0,5 kg		0,6 kg	0,65 kg
Dimensions (h x w x d)	100 x 113 x 40 mm		100 x 113 x 50 mm	100 x 113 x 60 mm
STANDARDS				
Safety	EN/IEC 62109-1, UL 1741, CSA C22.2			
STORED TRENDS				
Data stored	Battery voltage, current and temperature, as well as load output current, PV voltage and PV current.			
Number of days trends data is stored	46			
1a) If more PV power is connected, the controller will limit input power. 1b) The PV voltage must exceed Vbat + 5 V for the controller to start. Thereafter the minimum PV voltage is Vbat + 1 V 2) A PV array with a higher short circuit current may damage the controller.				

SmartSolar charge controller MPPT 100/30 & 100/50



**SmartSolar Charge Controller
MPPT 100/50**



**Bluetooth sensing
Smart Battery Sense**



**Bluetooth sensing
BMV-712 Smart Battery Monitor**



Bluetooth Smart built-in

The wireless solution to set-up, monitor, update and synchronise SmartSolar Charge Controllers.

VE.Direct

For a wired data connection to a Color Control GX, other GX products, PC or other devices

Ultrafast Maximum Power Point Tracking (MPPT)

Especially in case of a clouded sky, when light intensity is changing continuously, an ultra-fast MPPT controller will improve energy harvest by up to 30 % compared to PWM charge controllers and by up to 10 % compared to slower MPPT controllers.

Advanced Maximum Power Point Detection in case of partial shading conditions

If partial shading occurs, two or more maximum power points may be present on the power-voltage curve. Conventional MPPTs tend to lock to a local MPP, which may not be the optimum MPP. The innovative BlueSolar algorithm will always maximize energy harvest by locking to the optimum MPP.

Outstanding conversion efficiency

No cooling fan. Maximum efficiency exceeds 98 %.
The full output current up to 40 °C (104 °F).

Flexible charge algorithm

Fully programmable charge algorithm (see the software page on our website), and eight pre-programmed algorithms, selectable with a rotary switch (see manual for details).

Extensive electronic protection

Over-temperature protection and power derating when temperature is high.
PV short circuit and PV reverse polarity protection.
PV reverse current protection.

Internal temperature sensor

Compensates absorption and float charge voltage for temperature.

Optional external battery voltage and temperature sensing via Bluetooth

A Smart Battery Sense or a BMV-712 Smart Battery Monitor can be used to communicate battery voltage and temperature to one or more SmartSolar Charge Controllers.

Fully discharged battery recovery function

Will initiate charging even if the battery has been discharged to zero volts.
Will reconnect to a fully discharged Li-ion battery with integrated disconnect function.

SmartSolar Charge Controller	MPPT 100/30	MPPT 100/50
Battery voltage	12/24 V Auto Select	
Rated charge current	30 A	50 A
Nominal PV power, 12 V 1a,b)	440 W	700 W
Nominal PV power, 24 V 1a,b)	880 W	1400 W
Maximum PV open circuit voltage	100 V	100 V
Max. PV short circuit current 2)	35 A	60 A
Maximum efficiency	98 %	98 %
Self-consumption	12 V: 30 mA 24 V: 20 mA	
Charge voltage 'absorption'	Default setting: 14,4 V / 28,8 V (adjustable)	
Charge voltage 'float'	Default setting: 13,8 V / 27,6 V (adjustable)	
Charge algorithm	multi-stage adaptive	
Temperature compensation	-16 mV / °C resp. -32 mV / °C	
Protection	PV reverse polarity Output short circuit Over temperature	
Operating temperature	-30 to +60 °C (full rated output up to 40 °C)	
Humidity	95 %, non-condensing	
Data communication port	VE.Direct See the data communication white paper on our website	
ENCLOSURE		
Colour	Blue (RAL 5012)	
Power terminals	16 mm ² / AWG6	
Protection category	IP43 (electronic components), IP22 (connection area)	
Weight	1,3 kg	
Dimensions (h x w x d)	130 x 186 x 70 mm	
STANDARDS		
Safety	EN/IEC 62109-1, UL 1741, CSA C22.2	
STORED TRENDS		
Data stored	Battery voltage, current and temperature, as well as load output current, PV voltage and PV current.	
Number of days trends data is stored	46	
1a) If more PV power is connected, the controller will limit input power. 1b) The PV voltage must exceed Vbat + 5 V for the controller to start. Thereafter the minimum PV voltage is Vbat + 1 V. 2) A PV array with a higher short circuit current may damage the controller.		

SmartSolar charge controller MPPT 150/35 & 150/45

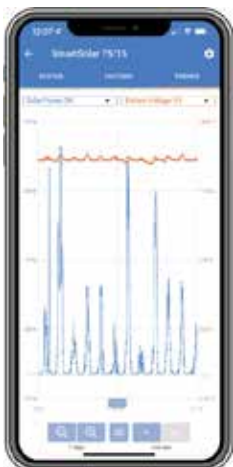
SmartSolar Charge Controller
MPPT 150/35Bluetooth sensing
Smart Battery SenseBluetooth sensing
BMV-712 Smart Battery Monitor**Bluetooth Smart built-in**

The wireless solution to set-up, monitor, update and synchronise SmartSolar Charge Controllers.

VE.Direct

For a wired data connection to a Color Control GX, other GX products, PC or other devices

Ultrafast Maximum Power Point Tracking (MPPT)

Especially in case of a clouded sky, when light intensity is changing continuously, an ultra-fast MPPT controller will improve energy harvest by up to 30 % compared to PWM charge controllers and by up to 10 % compared to slower MPPT controllers.

Advanced Maximum Power Point Detection in case of partial shading conditions

If partial shading occurs, two or more maximum power points may be present on the power-voltage curve.

Conventional MPPTs tend to lock to a local MPP, which may not be the optimum MPP.

The innovative BlueSolar algorithm will always maximize energy harvest by locking to the optimum MPP.

Outstanding conversion efficiency

No cooling fan. Maximum efficiency exceeds 98 %. Full output current up to 40 °C (104 °F).

Flexible charge algorithm

Fully programmable charge algorithm (see the software page on our website), and eight preprogrammed algorithms, selectable with a rotary switch (see manual for details).

Extensive electronic protection

- Over-temperature protection and power derating when temperature is high.
- PV short circuit and PV reverse polarity protection.
- PV reverse current protection.

Internal temperature sensor

Compensates absorption and float charge voltage for temperature.

Optional external battery voltage and temperature sensing via Bluetooth

A Smart Battery Sense or a BMV-712 Smart Battery Monitor can be used to communicate battery voltage and temperature to one or more SmartSolar Charge Controllers.

Fully discharged battery recovery function

Will initiate charging even if the battery has been discharged to zero volts.

Will reconnect to a fully discharged Li-ion battery with integrated disconnect function.

SmartSolar Charge Controller	MPPT 150/35	MPPT 150/45
Battery voltage	12 / 24 / 48 V Auto Select (software tool needed to select 36 V)	
Rated charge current	35 A	45 A
Nominal PV power 1a, b)	35 A 12 V: 500 W / 24 V: 1000 W / 36 V: 1500 W / 48 V: 2000 W 45 A 12 V: 650 W / 24 V: 1300 W / 36 V: 1950 W / 48 V: 2600 W	
Max. PV short circuit current 2)	40 A	50 A
Maximum PV open circuit voltage	150 V absolute maximum coldest conditions 145 V start-up and operating maximum	
Maximum efficiency	98 %	
Self-consumption	12 V: 20 mA	24 V: 15 mA 48 V: 10 mA
Charge voltage 'absorption'	Default setting: 14,4 / 28,8 / 43,2 / 57,6 V (adjustable)	
Charge voltage 'float'	Default setting: 13,8 / 27,6 / 41,4 / 55,2 V (adjustable)	
Charge algorithm	multi-stage adaptive (eight pre-programmed algorithms)	
Temperature compensation	-16 mV / -32 mV / -64 mV / °C	
Protection	PV reverse polarity / output short circuit / over-temperature	
Operating temperature	-30 to +60°C (full rated output up to 40°C)	
Humidity	95 %, non-condensing	
Data communication port	VE.Direct See the data communication white paper on our website	
ENCLOSURE		
Colour	Blue (RAL 5012)	
Power terminals	16 mm ² / AWG6	
Protection category	IP43 (electronic components), IP22 (connection area)	
Weight	1,25 kg	
Dimensions (h x w x d)	130 x 186 x 70 mm	
STANDARDS		
Safety	EN/IEC 62109-1, UL 1741, CSA C22.2	
STORED TRENDS		
Data stored	Battery voltage, current and temperature, as well as load output current, PV voltage and PV current.	
Number of days trends data is stored	46	
1a) If more PV power is connected, the controller will limit input power. 1b) The PV voltage must exceed Vbat + 5 V for the controller to start. Thereafter the minimum PV voltage is Vbat + 1 V. 2) A PV array with a higher short circuit current may damage the controller.		



SmartSolar Charge Controller
MPPT 150/70-Tr
without optional display



SmartSolar Charge Controller
MPPT 150/70-Tr
with optional display



Bluetooth sensing:
Smart Battery Sense



Bluetooth sensing:
BMV-712 Smart Battery Monitor



Bluetooth sensing: SmartShunt



SmartSolar pluggable display



Bluetooth Smart built-in

The wireless solution to set-up, monitor, update and synchronise SmartSolar Charge Controllers.

Ultra-fast Maximum Power Point Tracking (MPPT)

Especially in case of a cloudy sky, when light intensity is changing continuously, an ultra-fast MPPT controller will improve energy harvest by up to 30 % compared to PWM charge controllers and by up to 10 % compared to slower MPPT controllers.

Advanced Maximum Power Point Detection in case of partial shading conditions

If partial shading occurs, two or more maximum power points (MPP) may be present on the power-voltage curve.

Conventional MPPTs tend to lock to a local MPP, which may not be the optimum MPP.

The innovative SmartSolar algorithm will always maximize energy harvest by locking to the optimum MPP.

Outstanding conversion efficiency

No cooling fan. Maximum efficiency exceeds 98 %.

Flexible charge algorithm

Fully programmable charge algorithm (see the software page on our website), and eight pre-programmed algorithms, selectable with a rotary switch (see manual for details).

Extensive electronic protection

Over-temperature protection and power derating when temperature is high.

PV short circuit and PV reverse polarity protection.

PV reverse current protection.

Internal temperature sensor

Compensates absorption and float charge voltage for temperature.

Optional external battery voltage, temperature and current sensing via Bluetooth

A Smart Battery Sense, a BMV-712 Smart Battery Monitor or a SmartShunt can be used to communicate battery voltage and temperature (and current, in case of a BMV-712 or a SmartShunt) to one or more SmartSolar Charge Controllers.

Synchronized parallel charging with Bluetooth

Up to 10 units can be synchronized with Bluetooth.

Fully discharged battery recovery function

Will initiate charging even if the battery has been discharged to zero volts.

Will reconnect to a fully discharged Li-ion battery with integrated disconnect function.

VE.Direct

For a wired data connection to a Color Control GX, other GX products, PC or other devices

Remote on-off

To connect for example to a VE.BUS BMS.

Programmable relay

Can be programmed to trip on an alarm, or other events.

Optional: SmartSolar pluggable LCD display

Simply remove the rubber seal that protects the plug on the front of the controller, and plug-in the display.

SmartSolar charge controller MPPT 150/70 up to 150/100 VE.Can



SmartSolar Charge Controller
MPPT 150/100-Tr VE.Can
with optional pluggable display



SmartSolar Charge Controller
MPPT 150/100-Tr VE.Can
without display



Bluetooth sensing:
Smart Battery Sense



Bluetooth sensing:
BMV-712 Smart Battery Monitor



Bluetooth sensing: SmartShunt

Ultra-fast Maximum Power Point Tracking (MPPT)

Especially in case of a cloudy sky, when light intensity is changing continuously, an ultra-fast MPPT controller will improve energy harvest by up to 30 % compared to PWM charge controllers and by up to 10 % compared to slower MPPT controllers.

Advanced Maximum Power Point Detection in case of partial shading conditions

If partial shading occurs, two or more maximum power points (MPP) may be present on the power-voltage curve.

Conventional MPPTs tend to lock to a local MPP, which may not be the optimum MPP.

The innovative SmartSolar algorithm will always maximize energy harvest by locking to the optimum MPP.

Outstanding conversion efficiency

No cooling fan. Maximum efficiency exceeds 98 %.

Flexible charge algorithm

Fully programmable charge algorithm, and eight pre-programmed algorithms, selectable with a rotary switch (see manual for details).

Extensive electronic protection

Over-temperature protection and power derating when temperature is high.

PV short circuit and PV reverse polarity protection.

PV reverse current protection.

Bluetooth Smart built-in

The wireless solution to set-up, monitor, update and synchronise SmartSolar Charge Controllers.

Internal temperature sensor and optional external battery voltage, temperature and current sensing via Bluetooth

A Smart Battery Sense, a BMV-712 Smart Battery Monitor or a SmartShunt can be used to communicate battery voltage and temperature (and current, in case of a BMV-712 or a SmartShunt) to one or more SmartSolar Charge Controllers.

VE.Direct or VE.Can

For a wired data connection to a Color Control GX, other GX products, PC or other devices

Fully discharged battery recovery function

Will initiate charging even if the battery has been discharged to zero volts.

Will reconnect to a fully discharged Li-ion battery with integrated disconnect function.

VE.Can: the multiple controller solution

Up to 25 units can be synchronised with VE.Can, and up to 10 units with Bluetooth

Remote on-off

To connect for example to a VE.BUS BMS.

Programmable relay

Can be programmed to trip on an alarm, or other events.

Optional: SmartSolar pluggable LCD display

Simply remove the rubber seal that protects the plug on the front of the controller, and plug-in the display.



SmartSolar pluggable display

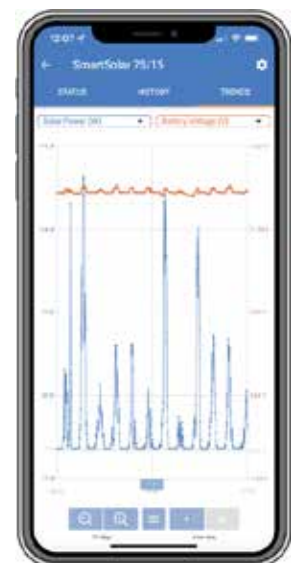



**SmartSolar Charge Controller
MPPT 250/70-Tr
with optional pluggable display**



**SmartSolar Charge Controller
MPPT 250/70-MC4
without display**



**Bluetooth sensing:
Smart Battery Sense**



**Bluetooth sensing:
BMV-712 Smart Battery Monitor**



Bluetooth sensing: SmartShunt

Bluetooth Smart built-in

The wireless solution to set-up, monitor, update and synchronise SmartSolar Charge Controllers.

Ultra-fast Maximum Power Point Tracking (MPPT)

Especially in case of a cloudy sky, when light intensity is changing continuously, an ultra-fast MPPT controller will improve energy harvest by up to 30 % compared to PWM charge controllers and by up to 10 % compared to slower MPPT controllers.

Advanced Maximum Power Point Detection in case of partial shading conditions

If partial shading occurs, two or more maximum power points (MPP) may be present on the power-voltage curve.

Conventional MPPTs tend to lock to a local MPP, which may not be the optimum MPP.

The innovative SmartSolar algorithm will always maximize energy harvest by locking to the optimum MPP.

Outstanding conversion efficiency

No cooling fan. Maximum efficiency exceeds 99 %.

Flexible charge algorithm

Fully programmable charge algorithm (see the software page on our website), and eight pre-programmed algorithms, selectable with a rotary switch (see manual for details).

Extensive electronic protection

Over-temperature protection and power derating when temperature is high.

PV short circuit and PV reverse polarity protection.

PV reverse current protection.

Internal temperature sensor and optional external battery voltage and temperature sensing via Bluetooth

A Smart Battery Sense, a BMV-712 Smart Battery Monitor or a SmartShunt can be used to communicate battery voltage and temperature (and current, in case of a BMV-712 or a SmartShunt) to one or more SmartSolar Charge Controllers

Synchronized parallel charging with Bluetooth

Up to 10 units can be synchronized with Bluetooth.

Fully discharged battery recovery function

Will initiate charging even if the battery has been discharged to zero volts.

Will reconnect to a fully discharged Li-ion battery with integrated disconnect function.

VE.Direct

For a wired data connection to a Color Control GX, other GX products, PC or other devices

Remote on-off

To connect for example to a VE.BUS BMS.

Programmable relay

Can be programmed (a.o. with a smartphone) to trip on an alarm, or other events.

Optional: SmartSolar pluggable LCD display

Simply remove the rubber seal that protects the plug on the front of the controller, and plug-in the display.



SmartSolar pluggable display



SmartSolar charge controller MPPT 250/70 up to 250/100 VE.Can



SmartSolar Charge Controller
MPPT 250/100-Tr VE.Can
with optional pluggable display



SmartSolar Charge Controller
MPPT 250/100-Tr VE.Can
without display



Bluetooth sensing:
Smart Battery Sense



Bluetooth sensing:
BMV-712 Smart Battery Monitor



Bluetooth sensing: SmartShunt

Ultra-fast Maximum Power Point Tracking (MPPT)

Especially in case of a cloudy sky, when light intensity is changing continuously, an ultra-fast MPPT controller will improve energy harvest by up to 30 % compared to PWM charge controllers and by up to 10 % compared to slower MPPT controllers.

Advanced Maximum Power Point Detection in case of partial shading conditions

If partial shading occurs, two or more maximum power (MPP) points may be present on the power-voltage curve.

Conventional MPPTs tend to lock to a local MPP, which may not be the optimum MPP.

The innovative SmartSolar algorithm will always maximize energy harvest by locking to the optimum MPP.

Outstanding conversion efficiency

No cooling fan. Maximum efficiency exceeds 99 %.

Flexible charge algorithm

Fully programmable charge algorithm, and eight pre-programmed algorithms, selectable with a rotary switch (see manual for details).

Extensive electronic protection

Over-temperature protection and power derating when temperature is high.

PV short circuit and PV reverse polarity protection.

PV reverse current protection.

Bluetooth Smart built-in

The wireless solution to set-up, monitor, update and synchronise SmartSolar Charge Controllers.

Internal temperature sensor and optional external battery voltage, temperature and current sensing via Bluetooth

A Smart Battery Sense, a BMV-712 Smart Battery Monitor or a SmartShunt can be used to communicate battery voltage and temperature (and current, in case of a BMV 712 or a SmartShunt) to one or more SmartSolar Charge Controllers.

VE.Direct or VE.Can

For a wired data connection to a Color Control GX, other GX products, PC or other devices.

Synchronized parallel charging with VE.Can or Bluetooth

Up to 25 units can be synchronized with VE.Can, and up to 10 units with Bluetooth.

Fully discharged battery recovery function

Will initiate charging even if the battery has been discharged to zero volts.

Will reconnect to a fully discharged Li-ion battery with integrated disconnect function.

VE.Can: the multiple controller solution

Up to 25 units can be synchronised with VE.Can.

Remote on-off

To connect for example to a VE.BUS BMS.

Programmable relay

Can be programmed to trip on an alarm, or other events.

Optional: SmartSolar pluggable LCD display

Simply remove the rubber seal that protects the plug on the front of the controller, and plug-in the display.



SmartSolar pluggable display

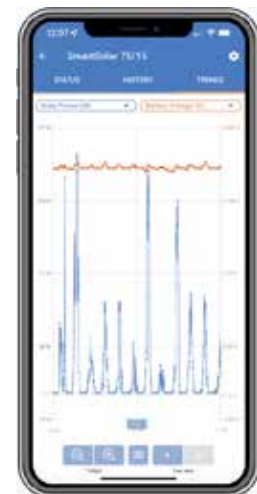

SmartSolar MPPT RS 450/100 & 450/200



SmartSolar MPPT RS 450|100

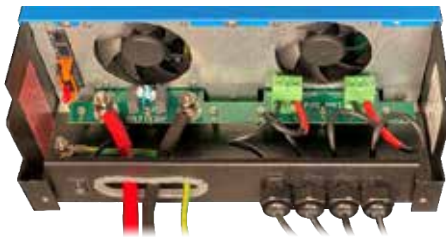

Inside the SmartSolar MPPT RS 450|100

Ultra-fast Maximum Power Point Tracking (MPPT) Solar Charge Controller

The MPPT RS SmartSolar is a 48 V Solar charge controller with up to 450 VDC PV input and either 100 A, or 200 A output. It is used in on-grid and off-grid solar applications where maximum battery charging power is required.

Multiple independent MPPT tracking inputs

With multiple MPPT trackers, you can optimize your solar panel design for maximum performance for your specific location.

Isolated PV connections for additional safety

Full galvanic isolation between PV and battery connections provide additional overall system safety.

Wide MPPT voltage range

80 – 450 VDC PV operating range, with a 120 VDC PV startup voltage.

Light weight, efficient and quiet

Thanks to high frequency technology and a new design this powerful charger weighs only 7.9 kg for the 100 A model. In addition to this it has an excellent efficiency, low standby power, and a very quiet operation.

Display and Bluetooth

The display reads battery, and controller parameters. The parameters can be accessed with a smartphone or other Bluetooth enabled device. In addition, Bluetooth can be used to set up the system and to change settings with VictronConnect.

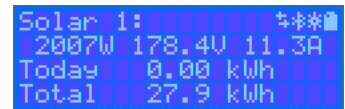

PV Isolation resistance monitoring for peace of mind at higher voltages

The MPPT RS continuously monitors the PV array and can detect if there are faults that reduce the isolation of the panels to unsafe levels.

VE.Can and VE.Direct port

For connection to a GX device for system monitoring, data logging, and remote firmware updates. VE.Can allows for up to 25 units to be connected together in parallel and synchronize their charging.

I/O Connections

Programmable Relay, temperature sensor, auxiliary, digital input and voltage sensor connections. The remote input can accept the Victron smallBMS, and other BMS with allow-to-charge signal.

Configure and monitor with VictronConnect →

The built-in Bluetooth Smart connection allows for quick monitoring and settings adjustment.

The built-in 30-day history shows individual performance of the separate MPPT trackers.

Try the VictronConnect demo to see the full range of configuration and display options with sample data.



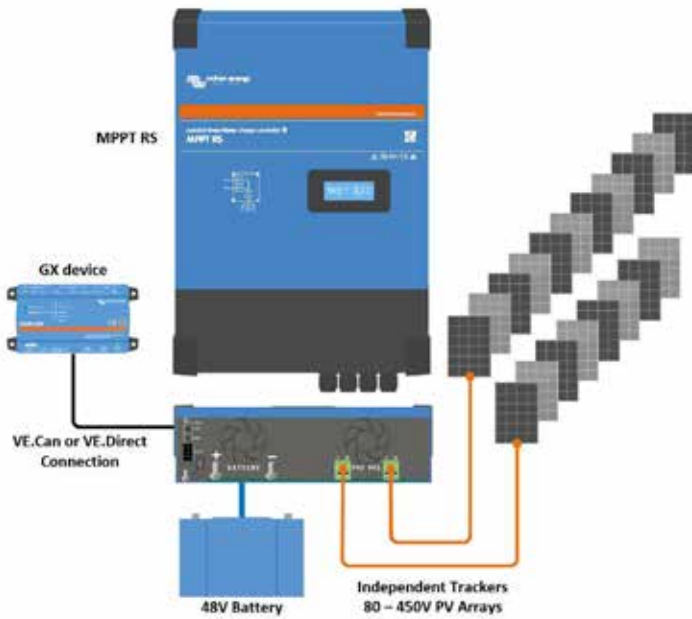

System example diagram

The 100 A MPPT RS combined with a GX device, charging a 48 V battery with 2 separate solar PV strings.

VRM Portal

When the MPPT RS is connected to a GX device with internet connection, or the GlobalLink 520 with built in 4G connectivity, you can access our free remote monitoring website (VRM). This will display all your system data in a comprehensive graphical format. Alarms can be received by e-mail.

Isolated SmartSolar MPPT RS	450 100	450 200
CHARGER		
Battery voltage	48 V	
Rated charge current	100 A	200 A
Maximum charge power	5,8 kW at 57,6 V	11,5 kW at 57,6 V
Charge voltage 'absorption'	Default setting: 57,6 V (adjustable)	
Charge voltage 'float'	Default setting: 55,2 V (adjustable)	
Programmable voltage range	Minimum: 36 V Maximum: 60 V ⁽⁷⁾	
Charge algorithm	Multi-stage adaptive (adjustable)	
Battery temperature sensor	Included	
Maximum efficiency	96 %	
Self-consumption	15 mA	
SOLAR		
Maximum DC PV voltage	450 V	
Start-up voltage	120 V	
MPPT operating voltage range	80 – 450 V ⁽¹⁾	
Number of trackers	2	4
Max. PV operational input current	18 A per tracker	
Max. PV short circuit current ⁽²⁾	20 A per tracker	
Max. DC output charging power	4000 W per tracker 5760 W total	4000 W per tracker 11520 W total
Maximum PV array size per tracker ⁽³⁾	7200 Wp (450 V x 20 A) ⁽³⁾	
PV Isolation fail level ⁽⁴⁾	100 kΩ	

GENERAL	
Synchronised Parallel Operation	Yes, up to 25 units with VE.Can
Programmable relay ⁽⁵⁾	Yes
Protection	PV reverse polarity Output short circuit Over temperature
Data communication	VE.Direct port, VE.Can port & Bluetooth (6)
Bluetooth frequency	2402 – 2480 MHz
Bluetooth power	4dBm
General purpose analogue/digital in port	Yes, 2x
Remote on-off	Yes
Operating temperature range	-40 to +60 °C (fan assisted cooling)
Humidity (non-condensing)	max 95 %

ENCLOSURE	
Material & Colour	steel, blue RAL 5012
Protection category	IP21
Battery-connection	M8 bolts
Power terminals PV input	2 16 mm ²
Weight	7.9 kg 13.7 kg
Dimensions (h x w x d) in mm	440 x 313 x 126 487 x 434 x 146

STANDARDS	
Safety	EN-IEC 62109-1, EN-IEC 62109-2
Country of Origin	Designed in The Netherlands, made in India

- 1) MPPT operating voltage range is constrained by battery voltage - PV VOC should not exceed 8 x battery float voltage. For example, a 52,8 V float voltage results in a maximum PV VOC of 422,4 V. See product manual for further information.
- 2) A higher short circuit current may damage the controller if PV array is connected in reverse polarity.
- 3) Max. 450 VOC result in appr. 360 Vmpp, therefore the maximum PV array is appr. 360 V x 20 A = 7200 Wp.
- 4) The MPPT RS will test for sufficient resistive isolation between PV+ and GND, and PV- and GND. In the event of a resistance below the threshold, the unit will stop charging, display the error, and send the error signal to the GX device (if connected) for audible and email notification.
- 5) Programmable relay which can be set for general alarm, DC under voltage or genset start/stop function. DC rating: 4 A up to 35 VDC and 1 A up to 70 VDC
- 6) The MPPT RS is currently not compatible with VE.Smart Networks.
- 7) The Charger set-point (float and absorption) can be set to max 60 V. The output voltage at the charger terminals can be higher, due to temperature compensation as well as compensation for voltage drop over the battery cables. The maximum output current is reduced on a linear basis from full current at 60 V to 5 A at 62 V. The equalization voltage can be set to max 62V, the equalization current percentage can be set to max 6%.



About Victron Energy

With over 47 years of experience, Victron Energy enjoys an unrivalled reputation for technical innovation, reliability and quality. Victron is a world leader in the supply of self-supporting electrical power. Our products have been designed to meet the most demanding situations faced by a diversity of craft, recreational and commercial alike. Victron's ability to meet the demand for customized off-grid systems is unprecedented. Our product range includes sine wave inverters and inverter/chargers, battery chargers, DC-DC converters, transfer switches, gel and AGM batteries, battery monitors, solar charge controllers, solar panels, complete network solutions and many other innovative solutions.

World-wide service and support

Having served the off-grid, industrial and vehicle markets as well as both the commercial and leisure marine sectors for over 47 years, Victron has an established network of dealers and distributors covering the whole world. Our customer base is such that providing prompt and competent local service is essential.

This is reflected in the capabilities of our support network. Our flexible approach to service support and our commitment to quick turnaround for repairs is marketleading. There are countless examples of Victron products that have provided for decades of reliable service in the most demanding applications. This level of reliability combined with the highest level of technical know-how results in Victron Energy power systems that offer the very best value available.







SAL064140020
REV 09
2022-10



Victron Energy B.V.

De Paal 35 • 1351JG Almere • The Netherlands
E-mail: sales@victronenergy.com
www.victronenergy.com

