



NORTH AMERICA AC DRIVE PRODUCT CATALOG

EFFECTIVE JANUARY 2015

VACON[®]
DRIVEN BY DRIVES

CREATING DEPENDABLE SOLUTIONS WORLDWIDE

Our AC drives provide the best possible solutions for gaining remarkable energy savings and achieving total effectiveness in production. Vacon variable speed AC drives also guarantee the quality and functionality in all phases of an industrial process, from raw materials to finished products. Listed below are a few of the recent successes that have occurred in the United States and Canada.



ENERGY AND COST-EFFICIENT VENTILATION FOR ALASKAN MINE

Canary birds are especially sensitive to methane and carbon monoxide and at one time were regularly used in coal mining as an early warning system: any signs of distress from a bird indicated to the miners that conditions were unsafe. Today's mines are ventilated. Using VACON® AC drives to control fans and blowers at a mine in Alaska has significantly improved the energy-efficiency of the ventilation system.



CONVEYING THE SOLUTION

In 2010, Bunge Grain associates attended the Vacon Drive Ahead Road Show Tour in New Orleans, LA, USA, to learn more about Vacon. They realized that they had an application at their plant in Destrehan, LA, that could really benefit from a Vacon AC drive.



INNOVATIVE AIR COMPRESSOR PUTS THE SQUEEZE ON THE COMPETITION

Located in Barrie, Ontario, Canada, one hour north of Toronto, DV Systems Inc. has been manufacturing high-quality air compressors for over 50 years. In 2009, DV Systems started the process of developing more advanced compressor technology: a low-cost rotary screw compressor with a low amp start and high performance, designed for commercial applications.



DRILLING HOLES IN CANADA

High-performance Vacon NXP forms heart of unique single spindle, 3-axis beam drilling system by Edge Automation.



ICONIC MOMENT IN GOLD RECOVERY

In small-scale gold recovery operations, the methods used by miners are often unsafe and hazardous to their health. For instance, using mercury to recover gold in artisanal mining can cause serious long term problems and even death.



HORSE WALKERS DRIVEN BY VACON X4

J P Livestock Co in Marana, Arizona, USA, has over 80 quarter horses. It would take many cowboys to perform daily exercise routines for this many horses, but J P Livestock has a Trojan horse walker. Trojan manufactures state of the art horse walking machines with automated exercise programmes to accommodate almost any need from exercise to rehabilitation.



WORLD'S FIRST TRUE HYBRID TUG SETS NEW BENCHMARK

The world's first true hybrid tug was unveiled in January 2009 in southern California, United States. Named the 'Carolyn Dorothy', the tug is powerful, green and quiet. She is likely to have many followers, as hybrid tugs are expected to be a significant trend in the marine industry. Vacon AC drives technology is used as part of the hybrid propulsion system.



COMPACT, LIQUID COOLED DRIVE FOR CEMENTING SYSTEMS

Drilling for oil & gas involves many processes and special components. One crucial step in the drilling process is to cement the riser and casing pipe. As drilling depths increase, the size of the electrical cementing pumps continues to increase.

CREATING DEPENDABLE SOLUTIONS WORLDWIDE



HAVE A LITTLE WINE WITH YOUR VACON X4

Rodney Strong Vineyards is dedicated to crafting world-class wines with complexity and expression that capture the essence of Sonoma County in Northern California, United States. Rodney Strong Vineyards grows and produces wines exclusively from four of Sonoma County's finest appellations; Alexander Valley, Russian River Valley, Chalk Hill and Sonoma Coast. The winery's twelve unique estate vineyards represent the perfect marriage of varietal selection and soil composition.



A MAJESTIC BARGE

When MegaDrill Services Limited, based in Houston, TX, USA, decided to design and build the most technologically advanced drilling barge in the world, they had many challenges ahead of them. The decision to partner with Integrated Drive Systems (IDS), Inc. in Houston, TX, to build the power, control and drilling systems was an easy choice, however.



MEGA YACHT WITH INNOVATIVE HVAC SOLUTION

Dometic Group's Marine Division in Pompano Beach in Florida, USA, has 50 years experience in producing seaworthy HVAC systems. On their compressor system, they needed a solution to minimize harmonic distortions and radio frequency interference without costly line filters and conditioners. Vacon Inc. in the US and Canada – in cooperation with their partners – provided a solution: a bypassable variable frequency drive.



VACON PROPELS NORTHERN LEADER

J.M. Martinac Shipbuilding in Tacoma, WA, United States, has been building ships since 1924. The company started with fishing vessels, and over the years has built more than 300 vessels of various types. Martinac's latest project, the Northern Leader, is the largest longliner ever built in the US and one of the largest in the world. It is also eco-friendly.



POULTRY DRIVES INDUSTRY ON THE EASTERN SHORE

Nestled in among the absolute beauty and serenity of the Eastern Shore of Delaware, Maryland and Virginia, many large, well-known companies provide most of the poultry products across the United States. Only the most rugged equipment survives in this harsh industrial environment, where high production rates require reliable machinery and service.



RETROFITTING A RAYMOND MILL

Gypsum is an ancient, versatile material that was once used as plaster in the Egyptian pyramids. Today it is most commonly used in gypsum board in homes and commercial buildings. Smooth grinding of the gypsum rock into fine powder is essential for guaranteeing the quality of the end product. After a retrofitting project at National Gypsum Company's Portsmouth site, a ball mill manufactured by Raymond is now fitted with Vacon X5 variable speed AC drives. AC drive control improves the process significantly.



TURBO BLOWERS SAVE ENERGY IN WATER TREATMENT

Aeration blowers have an important task in wastewater treatment, but their handicap is high energy consumption. Houston, Texas based company, HSI, introduced in early 2008 the air bearing HT series blower, which can reduce energy costs by 20-40%. Vacon AC drives are used for speed control.



RETROFITTING AT WAUSAU WATER WORKS

In June 2011, Pat Vanouse, Senior Plant Maintenance Mechanic at Wausau Water Works, was introduced to Vacon during Vacon North America's Drive Ahead Road Show Tour. Attending the local event at Vacon distributor Linder Electric Motors Inc, Wausau, WI, he was very impressed by the vast range of products and the state of the art technology that VACON® AC drives had to offer.



SIZE MATTERS TO WICHITA CLUTCH

Demand in the Marine & Offshore industry has grown exponentially in recent years, and technology has increased along with it. Adding the latest technology to existing solutions often requires a careful balancing act in order to avoid having to completely replace the old installation – wasting time and valuable components – and ensuring that the new parts work in unison with old parts. So when Wichita Clutch decided to double the throughput and capacity of their existing 1500 HP test stand for brakes, the knowledge and expertise that comes with VACON® Engineering was to prove vital.

VACON IN BRIEF

Vacon is driven by a passion to develop, manufacture and sell the best AC drives and inverters in the world - and provide customers with efficient product lifecycle services. Our AC drives offer optimum process control and energy efficiency for electric motors. Vacon inverters play a key role when energy is produced from renewable sources. Vacon has production and R&D facilities in Europe, Asia and North America, and sales offices in 31 countries. Further, Vacon has sales representatives and service partners in nearly 90 countries. In 2013, Vacon's revenues amounted to EUR 403.0 million, and the company employed globally approximately 1,600 people. The shares of Vacon Plc (VAC1V) are quoted on the main list of the Helsinki stock exchange (NASDAQ OMX Helsinki). Vacon is part of Danfoss Group.

PASSIONATE ATTITUDE TOWARDS PRODUCT LEADERSHIP

Exclusively focused on variable speed AC drives, VACON offers a unique blend of a dynamic and passionate attitude towards product leadership and customer services. VACON is constantly working with a wide customer base where AC drives play an integral part of the business.

VACON concentrates only on the essential: improving the customer's own product or process in order to bring the best possible value for the customer. With many years of experience in the field, we understand the customer's needs and can offer the most cost-effective solution to meet them in terms of process efficiency, energy savings, eco-friendliness, and the total cost of ownership.

UNIQUE CRAFTSMANSHIP AND R&D

More than 1,500 VACON professionals worldwide concentrate on one thing only: providing state-of-the-art AC drives as close to the customer as possible. The secret behind VACON's success lies in unique engineering craftsmanship and innovations. VACON's R&D is constantly investigating the best practices in the field that are most appropriate for customers.

Today, as much as 7% of the revenues are invested into R&D, and our R&D units are located in Finland, China, USA and Italy. Therefore, we dare to say that VACON AC drives make a difference in the market: whatever the need is - from the simplest to the most demanding - we are always open to take the challenge!

CLEANTECH WHICH BRINGS SUBSTANTIAL SAVINGS

VACON AC drives are 100% cleantech. Cleantech refers to all products, services, processes and systems that are less harmful to the environment than their alternatives. VACON AC drives represent technology that not only helps you save in energy costs but also significantly improves the process control in your business.

If all AC motors in the world were equipped with VACON AC drives, it could give savings of about 30% in the energy consumption of AC motors. This saving is about 10% of the world's total consumption of electrical energy.

ATTRACTIVE PARTNER

VACON has a unique position in the market. It is an independent company that can focus entirely on developing AC drives. A global network combined with local production in different parts of the world makes VACON an attractive business partner on all continents.

VACON offers OEM partners, system integrators, brand label customers, distributors and industrial end-users a broad product portfolio and a high level of product and application expertise.

GLOBAL PRODUCTION & MULTICHANNEL PRODUCT AND SERVICE NETWORK

VACON currently manufactures AC drives in Finland, China, Italy, India and the United States. Adapting products as close as possible to the customer gives flexible production and short delivery times.

VACON AC drives are sold in more than 100 countries. We have subsidiaries, business partners and service centers around the world. We increase our local presence systematically, ensuring good availability of products and service wherever you are.

VACON GROWS AT A FAST PACE

For many years, VACON has been growing two times faster than the global AC drive market. Today, VACON is one of the biggest AC drives manufacturers in the world. VACON's main competitors are global conglomerates, for which AC drives are just one product among many.

The growth in the AC drive market is based on rising energy prices, increasing automation, falling electronics prices, and investments in renewable energy generation. There is room for growth in the market, for at the moment only about 10% of the electric motors in the world are controlled by AC drives.

VACON AMERICAS FACILITIES



UNITED STATES FACILITIES

VACON, Inc.

310 W. Wisconsin Avenue, Suite 120M
Milwaukee, WI 53203
Office: 717-261-5000
Fax: 262-242-1491

VACON, Inc.

1500 Nitterhouse Drive
Chambersburg, PA 17201
Office: 717-261-5000
Fax: 717-261-5098

VACON, Inc.

12 TW Alexander Drive Building 200A
Research Triangle Park, NC 27709
Office: 717-261-5000

Vacon Competence Center

6101 Enterprise Drive, Ste 100
Chattanooga, TN 37421
Office: 717-261-5000
Fax: 423-894-0495

Vacon Competence Center

15109 Heathrow Forest Parkway
Suite 180
Houston, Texas 77032
Office: 717-261-5000

CANADA FACILITY

VACON Canada, Inc.

1100 South Service Road, Suite 116
Stoney Creek, Ontario L8E 0C5
Canada
Office: 905-643-5401

MEXICO, D.F., MEXICO

MEXICO FACILITY

VACON Mexico

Vaasa Control de Mexico S.A. de C.V.
Oriente 235C No.272
Col: Agricola Oriental
Mexico, D.F., C.P. 08500
Office: 00 52 55 55580497

BRAZIL FACILITY

VACON Latin America

Al. Rio Preto 554, 06460-050,
Barueri, Brasil
Office: +55 11 3173-7800
Fax: +55 11 3173-7801

BARUERI, SP BRAZIL

CUSTOMER SERVICE

Customer Service - USA





1-877-822-6606
1-877-VACON-06, menu 1
Office: 717-261-5000
Fax: 717-261-5098
Orders.Chambersburg@vacon.com

Customer Service - Canada





Office: 905-643-5401
Fax: 905-643-0400
orders.canada@vacon.com

Additional information about VACON AC Drives can also be obtained by visiting www.vacon.com or calling 1-877-VACON-06.





PRODUCT OVERVIEW

	VACON 10	VACON 20	VACON 20 CP	VACON 20 X
	IP20 / IP21	IP20 / IP21	IP00	IP66
				
1-ph 110-120 VAC	0.33 - 1.5 HP / 0.25 - 1.1 kW	0.33 - 1.5 HP / 0.25 - 1.1 kW	-	-
1-ph 208-240 VAC	0.33 - 3.0 HP / 0.25 - 2.2 kW	0.33 - 3.0 HP / 0.25 - 2.2 kW	1.0 - 2.0 HP / 0.75 - 1.5 kW	1.0 - 2.0 HP / 0.75 - 1.5 kW
3-ph 208-240 VAC	0.33 - 3.0 HP / 0.25 - 2.2 kW	0.33 - 15 HP / 0.25 - 11 kW	1.0 - 5.0 HP / 0.75 - 4.0 kW	1.0 - 5.0 HP / 0.75 - 4.0 kW
3-ph 380-480 VAC	0.5 - 7.5 HP / 0.25 - 5.5 kW	0.5 - 25 HP / 0.37 - 18.5 kW	1.0 - 10 HP / 0.75 - 7.5 kW	1.0 - 10 HP / 0.75 - 7.5 kW
3-ph 380-500 VAC	-	-	-	-
3-ph 600 VAC	1.0 - 7.5 HP / 0.75 - 5.5 kW	1.0 - 7.5 HP / 0.75 - 5.5 kW	-	-
3-ph 525-690 VAC	-	-	-	-
Overloadability	1,5 - IN	1,5 - IN	1,5 - IN	1,5 - IN
Ambient operating temperature	-10 (no frost) ...+50°C (+40°C for some types, side-by-side installation and IP21 option)	-10 (no frost) ...+50°C (+40°C for some types, side-by-side installation and IP21 option)	-10(no frost) ...+70°C	-10 (no frost)...+40°C (+50°C with derating)
Brake chopper	Yes Standard: 3-ph MI2-MI3 units Not in MI1 and 1-ph models	Yes Standard: 3-ph MI2-MI5 units Not in MI1 and 1-ph models	Yes Only in 3-phase version	Yes Only in 3-phase version
Conformal coating	Standard	Standard	-	-
Flange Mounting	-	Option: MI4 - MI5	-	-
Drive supply switch	-	-	-	Option: MU2-MU3
Real time clock	-	-	-	-
AI analogue inputs	1 - 0-10V, 1 - 0(4)-20mA	1 - 0-10V, 1 - 0-10V / 0(4)-20mA	2 - 0-10V / 0(4)-20mA	2 - 0-10V / 0(4)-20mA
AO analogue outputs	1 - 0(4)-20mA	1 - 0-10V / 0(4)-20mA	1 - 0-10V	1 - 0-10V
DI digital inputs	6	6 [2 pulse train inputs]	6	6
DO digital outputs	1 [Open collector]	1 [Open collector]	1 [Open collector]	1 [Open collector]
RO relay outputs	1 - NO, 1 - NO/NC	1 - NO, 1 - NO/NC	1 - NO, 1 - NO/NC	1 - NO, 1 - NO/NC
Expansion slot for I/O and Fieldbus	-	1 Slot	1 Slot	1 Slot
Standard Onboard Communication	RS 485	RS 485	RS 485	RS 485
Fieldbus Communication	-	-	-	-
Modbus RTU	Standard	Standard	Standard	Standard
Metasys N2	-	-	-	-
Profibus DP	-	Option OPT-E3/5	Option OPT-C3/C5/E3/E5	Option OPT-C3/C5/E3/E5
DeviceNet	-	Option OPT-E7	Option OPT-C7/E7	Option OPT-E7
CANOpen	-	Option OPT-E6	Option OPT-C6/E6	Option OPT-C6/E6
BACnet MSTP	-	-	-	-
LonWorks	-	-	Option OPT-C4	Option OPT-C4
Modbus/TCP	-	-	Option OPT-C1	Option OPT-C1
BACnet IP	-	-	-	-I
Ethernet/IP	-	-	Option OPT-CQ	Option OPT-CQ
Profinet IO	-	-	Option OPT-CP	Option OPT-CP
EtherCAT	-	Option OPT-EC	Option OPT-EC	Option OPT-EC
STO Safe Torque Off	-	-	Standard, EN/IEC61800-5-2 STO SIL3, EN ISO 13849-1 PL "e" Category 4, EN62061: SIL3, IEC61508: SIL3	Standard, EN/IEC61800-5-2 STO SIL3, EN ISO 13849-1 PL "e" Category 4, EN62061: SIL3, IEC61508: SIL3
SS1 Safe Stop 1	-	-	-	-
Thermistor input	-	Option [OPT-B2]	Option OPT-B2	Option OPT-B2
ATEX Thermistor input	-	-	-	-
Tool for SW update and drive monitoring	Vacon Live	Vacon Live	Vacon Live	Vacon Live
Tool for application tailoring	-	Vacon Programming	Vacon Programming	Vacon Programming
Other PC tools	Vacon Save	Vacon Save	Vacon Save	Vacon Save

PRODUCT OVERVIEW

VACON 100	VACON 100 FLOW	VACON 100 HVAC	VACON100 X	
IP00 / IP21 / IP54 	IP00 / IP21 / IP54 	IP00 / IP21 / IP54 	IP66 	
-	-	-	-	1AC 110-120 VAC
-	-	-	-	1AC 208-240 VAC
0.75 - 125 HP / 0.55 - 90 kW	0.75 - 125 HP / 0.55 - 90 kW	0.75 - 125 HP / 0.55 - 90 kW	1.5 - 20 HP / 1.1 - 15kW	3AC 208-240 VAC
-	-	-	1.5 - 50 HP / 1.1 - 37 kW	3AC 380-480 VAC
1.5 - 250 HP / 1.1 - 160 kW	1.5 - 250 HP / 1.1 - 160 kW	1.5 - 250 HP / 1.1 - 160 kW	1.5 - 50 HP / 1.1 - 37 kW	3AC 380-500 VAC
-	-	-	-	3AC 600 VAC
-	-	-	-	3AC 525 - 690 VAC
1,1 - IL, 1,5 - IH	1,1 - IL	1,1 - IL	1,5 - IN	Overloadability
-10°C (no frost)...+50°C: IH -10°C (no frost)...+40°C: IL (50°C with derating 1.5% per degree /°C)	-10°C (no frost)...+40°C (50°C with derating 1.5% per degree /°C)	-10°C (no frost)...+40°C (50°C with derating 1.5% per degree /°C)	-10°C (no frost) ...+40°C [+60°C with derating] [-40°C with arctic mode option]	Ambient operating temperature
Yes Standard: MR4-MR6 Option: MR7-MR9	-	-	Standard	Brake chopper
Standard	Standard	Standard	-	Conformal coating
Option: MR4-MR7 Factory option: MR8-MR9	Option: MR4-MR7 Factory option: MR8-MR9	Option: MR4-MR7 Factory option: MR8-MR9	Option: note motor mounting flange	Flange Mounting
Factory option MR4-MR7	Factory option MR4-MR7	Factory option MR4-MR7	Option: MM4-MM6	Drive supply switch
Yes, option: RTC battery	Yes, option: RTC battery	Yes, option: RTC battery	Yes, option: RTC battery	Real time clock
2 - 0-10V / 0(4)-20mA	2 - 0-10V / 0(4)-20mA	2 - 0-10V / 0(4)-20mA	2 - 0-10V / 0(4)-20mA	AI analogue inputs
1 - 0-10V / 0(4)-20mA	1 - 0-10V / 0(4)-20mA	1 - 0-10V / 0(4)-20mA	1 - 0-10V / 0(4)-20mA	AO analogue outputs
6	6	6	6	DI digital inputs
-	-	-	-	DO digital outputs
+SBF3: 2 - NO/NC, 1 - NO standard +SBF4: 2 - NO/NC, Therm.	+SBF3: 2 - NO/NC, 1 - NO standard +SBF4: 2 - NO/NC, Therm.	+SBF3: 2 - NO/NC, 1 - NO standard +SBF4: 2 - NO/NC, Therm.	Standard 2 - NO/NC	RO relay outputs
3 Slots	3 Slots	3 Slots	2 Slots	Expansion slot for I/O and Fieldbus
Industrial Ethernet and RS 485	Industrial Ethernet and RS 485	Industrial Ethernet and RS 485	Industrial Ethernet and RS 485	Standard Onboard Communication Protocol
-	-	-	-	Fieldbus Communication
Standard	Standard	Standard	Standard	Modbus RTU
Standard	Standard	Standard	Standard	Metasys N2
Option OPT-E3/5	Option OPT-E3/5	-	Option OPT-E3/5	Profibus DP
Option OPT-E7	Option OPT-E7	-	Option OPT-E7	DeviceNet
Option OPT-E6	Option OPT-E6	-	Option OPT-E6	CANOpen
Standard	Standard	Standard	Standard	BACnet MSTP
Option OPT-C4	Option OPT-C4	Option OPT-C4	Option OPT-C4	LonWorks
Standard	Standard	Standard	Standard	Modbus/TCP
Standard	Standard	Standard	Standard	BACnet IP
On-board factory option +FBIE	On-board factory option +FBIE	-	On-board factory option +FBIE	Ethernet/IP
On-board factory option +FBIE	On-board factory option +FBIE	-	On-board factory option +FBIE	Profinet IO
Option OPT-EC	Option OPT-EC	-	-	EtherCAT
Option OPT-BJ (Slot E): SIL3, PL e, Category 3.	Option OPT-BJ (Slot E): SIL3, PL e, Category 3.	Option OPT-BJ (Slot E): SIL3, PL e, Category 3.	Standard, EN/IEC61800-5-2 STO SIL3, EN ISO 13849-1 PL "e" Category 4, EN62061: SIL3, IEC61508: SIL3	STO Safe Torque Off
Option OPT-BJ (Slot E): SIL2, PL d, Category 3	Option OPT-BJ (Slot E): SIL2, PL d, Category 3	Option OPT-BJ (Slot E): SIL2, PL d, Category 3	-	SS1 Safe Stop 1
Option +SBF4	Option +SBF4	Option +SBF4	Standard	Thermistor input
Option OPT-BJ (Slot E)	Option OPT-BJ (Slot E)	Option OPT-BJ (Slot E)	-	ATEX Thermistor input
Vacon Live	Vacon Live	Vacon Live	Vacon Live	Tool for SW update and drive monitoring
Vacon Programming and Drive customizer	Drive customizer	-	Vacon Programming and Drive customizer	Tool for application tailoring
Vacon Save	Vacon Save	Vacon Save	Vacon Save	Other PC tools

PRODUCT OVERVIEW

	VACON X4 / X5	VACON NXS	VACON NXP Air-Cooled	VACON NXC
		IP21 / IP54 	IP00 / IP21 / IP54 	IP21 / IP54 
1AC 110-120 VAC	1Hp / 0.75kW	-	-	-
1AC 208-240 VAC	5-15 Hp / 4 - 11 kW	-	-	-
3AC 208-240 VAC	1-25Hp / 0.75-18.5kW	1 - 125 HP / 0.75 - 90 kW	0.75 - 100 HP / 0.55 - 90 kW	-
3AC 380-480 VAC	1-200Hp / 0.75-132kW	-	-	-
3AC 380-500 VAC	-	1.5 - 600 HP / 1.1 - 400 kW	1.5 - 1600 HP / 1.1 - 1200 kW	200 - 1600 HP / 132 - 1200 kW, 6 pulse 300 - 1600 HP / 200 - 1200 kW, 12 pulse
3AC 600 VAC	1-200Hp / 0.75-132kW	-	-	-
3AC 525 - 690 VAC	-	3 - 500 HP / 2.2 - 560 kW	3 - 2250 HP / 3 - 2000 kW	125 - 2250 HP / 110 - 2000 kW, 6 pulse & 12 pulse
Overloadability	1.5 - IN	1,1 - IL, 1,5 - IH	1,1 - IL, 1,5 - IH	1,1 - IL, 1,5 - IH
Ambient operating temperature	-10C (no frost)...+40C	-10°C (no frost)...+50°C: IH (≥FR10 +40°C) -10°C (no frost)...+40°C: IL	-10°C (no frost)...+50°C: IH (≥FR10 +40°C) -10°C (no frost)...+40°C: IL	-10°C (no frost)...+40°C (+35°C) +40°C(+35°C)...+50°C with derating 1,5% for each 1°C
Brake chopper	Standard	Yes Standard: FR4-FR6 (30kW) Option: FR7 - FR11	Yes Standard: FR4-FR6 (30kW) Option: FR7 - FR11	Option: FR9-12 FR13-14 separate brake chopper unit (BCU)
Varnished Boards	X5 - Standard	Option	Standard (power unit only): FR7-14 Option: FR4-6	Standard (power unit only)
Flange Mounting	-	Option: FR4-FR9	Option: FR4-FR9	-
Drive supply switch	-	Factory option: FR10-FR11	Factory option: FR10-FR11	Option
Real time clock	X5 - Standard	-	-	-
AI analogue inputs	2-0-10V, 1-4-20ma	2 - 0-10V / 0(4)-20mA [OPT-A1]	2 - 0-10V / 0(4)-20mA [OPT-A1]	2 - 0-10V / 0(4)-20mA
AO analogue inputs	1-0-10V, 1-0(4)-20ma	1 - 0-10V / 0(4)-20mA [OPT-A1]	1 - 0-10V / 0(4)-20mA [OPT-A1]	1 - 0-10V / 0(4)-20mA
DI digital inputs	10	6 [OPT-A1]	6 [OPT-A1]	6 [OPT-A1]
DO digital outputs	2 [Open collector]	1 [Open collector] [OPT-A1]	1 [Open collector] [OPT-A1]	1 [Open collector] [OPT-A1]
RO relay outputs	2-NO/NC	1 - NO/NC, 1 - NO, Therm. [OPT-A3]	1 - NO/NC, 1 - NO, Therm. [OPT-A3]	1 - NO/NC, 1 - NO, Therm. [OPT-A3]
Expansion slot for I/O and Fieldbus	X5 - 1 Slot	5 Slots, 2 used as standard	5 Slots, 2 used as standard	5 Slots, 2 used as standard
Standard Onboard Communication Protocol	RS-485	-	-	-
Fieldbus Communication	-	-	-	-
Modbus RTU	STD	Option OPT-C2/8	Option OPT-C2/8	Option OPT-C2/8
Metasys N2	-	Option OPT-C2/8	Option OPT-C2/8	Option OPT-C2/8
Profibus DP	X5 Optional	Option OPT-C3/5	Option OPT-C3/5	Option OPT-C3/5
DeviceNet	-	Option OPT-C7	Option OPT-C7	Option OPT-C7
CANopen	-	Option OPT-C6	Option OPT-C6	Option OPT-C6
BACnet MSTP	-	Option OPT-CJ	Option OPT-CJ	Option OPT-CJ
LonWorks	-	Option OPT-C4	Option OPT-C4	Option OPT-C4
Modbus/TCP	X5 Optional	Option OPT-CI	Option OPT-CI	Option OPT-CI
BACnet IP	-	-	-	-
Ethernet/IP	X5 Optional	Option OPT-CQ	Option OPT-CQ	Option OPT-CQ
Profinet IO	-	Option OPT-CP	Option OPT-CP	Option OPT-CP
EtherCAT	-	-	-	-
STO	-	-	Option OPT-AF: EN/IEC 61800-5-2 STO SIL2, EN ISO 13849-1 PL"d" Category 3, EN 62061: SILCL2, IEC 61508: SIL2.	Option OPT-AF: EN/IEC 61800-5-2 STO SIL2, EN ISO 13849-1 PL"d" Category 3, EN 62061: SILCL2, IEC 61508: SIL2.
SS1	-	-	Option OPT-AF: EN /IEC 61800-5-2 Safe Stop 1 (SS1) SIL2, EN ISO 13849-1 PL"d" Category 3, EN /IEC62061: SILCL2, IEC 61508: SIL2.	EN /IEC 61800-5-2 Safe Stop 1 (SS1) SIL2, EN ISO 13849-1 PL"d" Category 3, EN / IEC62061: SILCL2, IEC 61508: SIL2.
Thermistor input	-	Standard [OPT-A3]	Option [OPT-A3]	Standard [OPT-A3]
ATEX Thermistor input	-	-	Option OPT-AF: 94/9/EC, CE 0537 Ex 11 [2] GD	Option OPT-AF: 94/9/EC, CE 0537 Ex 11 [2] GD
Tool for SW update and drive monitoring	Win-Trac	NCDrive NCLoad	NCDrive and NCLoad	NCDrive and NCLoad
Tool for application tailoring	-	Vacon Programming	Vacon Programming	Vacon Programming
Other PC tools	-	Vacon Save and Vacon Harmonics Simulator	Vacon Save and Vacon Harmonics Simulator	Vacon Save

PRODUCT OVERVIEW





VACON NXC Low Harmonic	VACON NXP Common DC Bus	VACON NXP System Drive	VACON NXP Liquid Cooled	
IP21 / IP54 	IP00 		IP00 	
-	-	-	-	1AC 110-120 VAC
-	-	-	-	1AC 208-240 VAC
-	-	-	-	3AC 208-240 VAC
-	-	-	-	3AC 380-480 VAC
200 - 2250 HP / 132 - 1500 kW, THDi <5%	System dependent Single INU unit up to 2700A (~1,5MW)	System dependent Single INU unit up to 2700A (~1,5MW)	10 - 6500 HP / 7.5 - 5150 kW	3AC 380-500 VAC
-	-	-	-	3AC 600 VAC
125 - 2250 HP / 110 - 2000 kW, THDi <5%	System dependent Single INU unit up to 2250A (~2,25MW)	System dependent Single INU unit up to 2250A (~2,25MW)	125 - 6000 HP / 110 kW - 5300 kW	3AC 525 - 690 VAC
1,1 - IL, 1,5 - IH	1,1 - IL, 1,5 - IH (INU)	1,1 - IL, 1,5 - IH	1,0 - Ith, 1,1 - IL cont., 1,5 - IH cont.	Overloadability
-10°C (no frost)...+40°C (+35°C) +40°C(+35°C)...+50°C with derating 1,5% for each 1°C	-10°C (no frost)...+40°C +40°C...+50°C with derating 1,5% for each 1°C	-10°C (no frost)...+35°C +35°C...+50°C with derating 1,5% for each 1°C	-10°C (no frost)...+50°C (at Ith); The NX liquid cooled drives must be used in an heated indoor controlled environment.	Ambient operating temperature
Optional external brake chopper	Separate brake chopper unit (BCU)	Optional external brake chopper	Standard: CH3 400V Option: CH72 400V/690V 6-p. and CH74 400V/690V 6-p & 12-p. Separate brake chopper unit (BCU)	Brake chopper
Standard (power unit only)	Standard (power unit only)	Standard (power unit only)	Standard (power unit only)	Varnished Boards
-	-	-	-	Flange Mounting
Standard	-	optional	-	Drive supply switch
-	-	-	-	Real time clock
2 - 0-10V / 0(4)-20mA	2 - 0-10V / 0(4)-20mA (OPT-A1)	2 - 0-10V / 0(4)-20mA	2 - 0-10V / 0(4)-20mA (OPT-A1)	AI analogue inputs
1 - 0-10V / 0(4)-20mA	1 - 0-10V / 0(4)-20mA (OPT-A1)	1 - 0-10V / 0(4)-20mA	1 - 0-10V / 0(4)-20mA (OPT-A1)	AO analogue inputs
6 (OPT-A1)	6 (OPT-A1)	6	6 (OPT-A1)	DI digital inputs
1 (Open collector) (OPT-A1)	1 (Open collector) (OPT-A1)	1 (Open collector)	1 (Open collector) (OPT-A1)	DO digital outputs
1 - NO/NC, 1 - NO, Therm. (OPT-A3)	1 - NO/NC, 1 - NO, Therm. (OPT-A3)	1 - NO/NC, 1 - NO, Therm. (OPT-A3)	1 - NO/NC, 1 - NO, Therm. (OPT-A3)	RO relay outputs
-	5 Slots, 2 used as standard	-	5 Slots, 2 used as standard	Expansion slot for I/O and Fieldbus
-	-	-	-	Standard Onboard Communication Protocol
-	Applies for INU	-	-	Fieldbus Communication
Option OPT-C2/8	Option OPT-C2/8	Option OPT-C2/8	Option OPT-C2/8	Modbus RTU
Option OPT-C2/8	Option OPT-C2/8	Option OPT-C2/8	Option OPT-C2/8	Metasys N2
Option OPT-C3/5	Option OPT-C3/5	Option OPT-C3/5	Option OPT-C3/5	Profibus DP
Option OPT-C7	Option OPT-C7	Option OPT-C7	Option OPT-C7	DeviceNet
Option OPT-C6	Option OPT-C6	Option OPT-C6	Option OPT-C6	CANOpen
Option OPT-CJ	Option OPT-CJ	Option OPT-CJ	Option OPT-CJ	BACnet MSTP
Option OPT-C4	Option OPT-C4	Option OPT-C4	Option OPT-C4	LonWorks
Option OPT-CI	Option OPT-CI	Option OPT-CI	Option OPT-CI	Modbus/TCP
-	-	-	-	BACnet IP
Option OPT-CQ	Option OPT-CQ	Option OPT-CQ	Option OPT-CQ	Ethernet/IP
Option OPT-CP	Option OPT-CP	Option OPT-CP	Option OPT-CP	Profinet IO
-	-	-	-	EtherCAT
Option OPT-AF: EN/IEC 61800-5-2 STO SIL2, EN ISO 13849-1 PL"d" Category 3, EN 62061: SILCL2, IEC 61508: SIL2.	Option OPT-AF: EN/IEC 61800-5-2 STO SIL2, EN ISO 13849-1 PL"d" Category 3, EN 62061: SILCL2, IEC 61508: SIL2.	Option OPT-AF: EN/IEC 61800-5-2 STO SIL2, EN ISO 13849-1 PL"d" Category 3, EN 62061: SILCL2, IEC 61508: SIL2.	Option OPT-AF: EN/IEC 61800-5-2 STO SIL2, EN ISO 13849-1 PL"d" Category 3, EN 62061: SILCL2, IEC 61508: SIL2.	STO
EN /IEC 61800-5-2 Safe Stop 1 (SS1) SIL2, EN ISO 13849-1 PL"d" Category 3, EN /IEC62061: SILCL2, IEC 61508: SIL2.	Option OPT-AF: EN /IEC 61800-5-2 Safe Stop 1 (SS1) SIL2, EN ISO 13849-1 PL"d" Category 3, EN /IEC62061: SILCL2, IEC 61508: SIL2.	EN /IEC 61800-5-2 Safe Stop 1 (SS1) SIL2, EN ISO 13849-1 PL"d" Category 3, EN / IEC62061: SILCL2, IEC 61508: SIL2.	Option OPT-AF: EN /IEC 61800-5-2 Safe Stop 1 (SS1) SIL2, EN ISO 13849-1 PL"d" Category 3, EN / IEC62061: SILCL2, IEC 61508: SIL2.	SS1
Option (OPT-A3)	Option (OPT-A3)	Standard (OPT-A3)	Option (OPT-A3)	Thermistor input
"Option OPT-AF: 94/9/EC, CE 0537 Ex 11 [2] GD"	Option OPT-AF: 94/9/EC, CE 0537 Ex 11 [2] GD	"Option OPT-AF: 94/9/EC, CE 0537 Ex 11 [2] GD"	Option OPT-AF: 94/9/EC, CE 0537 Ex 11 [2] GD	ATEX Thermistor input
NCDrive and NCLoad	NCDrive and NCLoad	NCDrive and NCLoad	NCDrive and NCLoad	Tool for SW update and drive monitoring
Vacon Programming	Vacon Programming	Vacon Programming	Vacon Programming	Tool for application tailoring
Vacon Save	Vacon Save and Vacon Harmonics Simulator	Vacon Save	Vacon Save and Vacon Harmonics Simulator	Other PC tools

TABLE OF CONTENTS

Contents	Page
VACON® 10	13
VACON® 20	19
VACON® 20 COLD PLATE	25
VACON® 20 X.....	31
VACON® 100	37
VACON® 100 FLOW.....	45
VACON® 100 HVAC	57
VACON® 100 X.....	65
VACON® X SERIES	71
VACON® X5 HAZLO.....	79
VACON® NXS.....	85
VACON® NXP & NXC	93
VACON® NXP Common DC Bus Products.....	113
VACON® NXP System Drive.....	123
VACON® NXP Liquid Cooled	131
VACON® 8000 Solar	149
VACON® PC Tools.....	155
VACON® AC Drive Type Code Keys.....	161

Contents	Page
Appendix	169
Application Guide by Industry Requirements	170
Enclosure Specifications and IP Ratings	172
EMC and Installation Environment	174
Agency Approvals	175
Marine and Offshore Approvals	176
Load Characteristics	177
Application Formulas	178
Glossary	180
General Terms and Conditions of Sale	189
Policies and Procedures	192
Notes	200

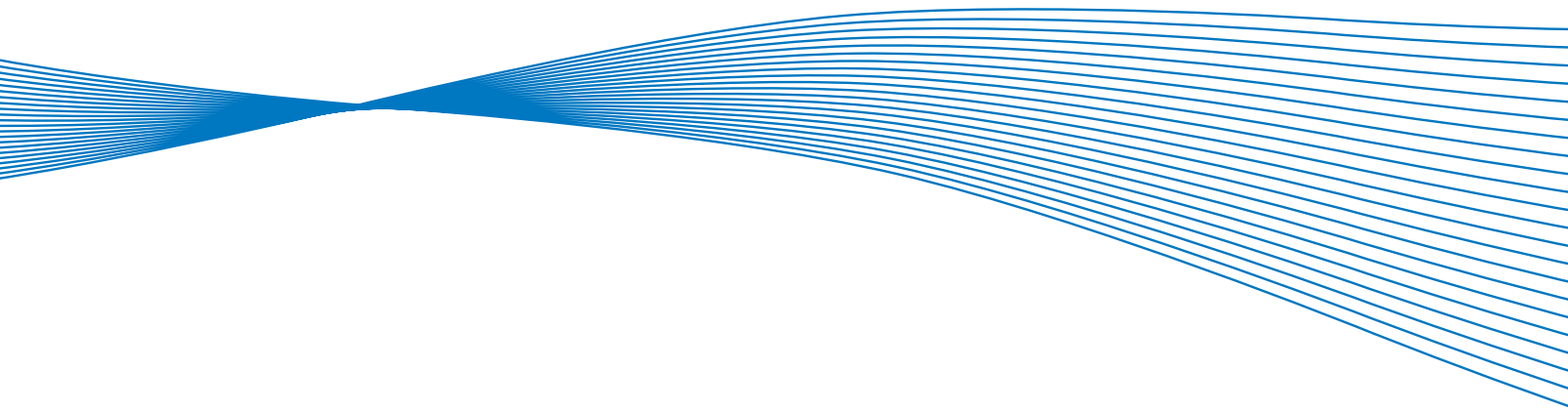

WE ARE DRIVES



VACON[®] 10



VACON® 10 – AS EASY AS POSSIBLE

VACON® 10 is an AC drive designed for applications where simplicity and efficiency are the key requirements. When you need a compact AC drive that does its job without extra hassle, the VACON® 10 is the product you should be taking a closer look at.

The leading design feature of the VACON® 10 is simplicity, which means short handling time. It has all the functionality built into one simple unit. Our VACON® 10 customers appreciate a quick setup and compact size.

FAST INSTALLATION

Choose VACON® 10, and benefit from the quick installation process. If the drive is mounted on a DIN rail no screws are required for the fixing. No external components, such as RFI filters etc., are needed as they can all be integrated into the drive.

FAST SETUP

In order to save our customers time, we have created tools to program the VACON® 10 as efficiently as possible. A start-up wizard in the drive allows for programming with as few as three parameters. With the MCA Unit, our customers can clone their drive in seconds - all without connecting main power to the drive.

COMPACT SIZE

The space available for the drive is often limited. It is also a cost factor as providing more space leads to increased cost for the enclosure. The secret behind the compact size of the VACON® 10 is the unique cooling concept of the drive. It is made just like most PC computers – a high efficiency forced cooled heat sink mounted directly onto the power semiconductors.

KEY BENEFITS:

- Short installation time
- Space saving design
- Parameter copying without main power

TYPICAL APPLICATIONS:

- Pumps
- Fans
- Conveyors

TECHNICAL HIGHLIGHTS:

- Easy to use push button interface
- Side by side mounting
- Wide standard I/O
- Integrated EMC Level C2 Filter Option
- Temperature controlled cooling fan
- PI controller built-in



RATINGS AND DIMENSIONS

Supply voltage	AC drive type	Output Power and Current High Overload (150%)			Frame size	Dimensions W x H x D		Weight	
		HP	kW	I _N (A)		mm	inches	kg	lb
110-120 VAC, 1-phase	VACON0010-1L-0001-1-R02	0.33	0.25	1.7	MI2	90 x 195 x 102	3.54 x 7.68 x 4.02	0.7	1.54
	VACON0010-1L-0002-1-R02	0.5	0.37	2.4					
	VACON0010-1L-0003-1-R02	0.75	0.55	2.8					
	VACON0010-1L-0004-1-R02	1	0.75	3.7					
	VACON0010-1L-0005-1-R02	1.5	1.1	4.8					
208-240 VAC, 1-phase	VACON0010-1L-0001-2-R02	0.33	0.25	1.7	MI1	66 x 160 x 99	2.60 x 6.30 x 3.90	0.55	1.21
	VACON0010-1L-0002-2-R02	0.5	0.37	2.4					
	VACON0010-1L-0003-2-R02	0.75	0.55	2.8					
	VACON0010-1L-0004-2-R02	1	0.75	3.7	MI2	90 x 195 x 102	3.54 x 7.68 x 4.02	0.7	1.54
	VACON0010-1L-0005-2-R02	1.5	1.1	4.8					
	VACON0010-1L-0007-2-R02	2	1.5	7					
	VACON0010-1L-0009-2-R02	3	2.2	9.6					
VACON0010-3L-0001-2-R02	0.33	0.25	1.7	MI1	66 x 160 x 99	2.60 x 6.30 x 3.90	0.55	1.21	
VACON0010-3L-0002-2-R02	0.5	0.37	2.4						
208-240 VAC, 3-phase	VACON0010-3L-0003-2-R02	0.75	0.55	2.8	MI2	90 x 195 x 102	3.54 x 7.68 x 4.02	0.7	1.54
	VACON0010-3L-0004-2-R02	1	0.75	3.7					
	VACON0010-3L-0005-2-R02	1.5	1.1	4.8					
	VACON0010-3L-0007-2-R02	2	1.5	7	MI3	100 x 255 x 109	3.94 x 10.04 x 4.29	0.99	2.18
	VACON0010-3L-0011-2-R02	3	2.2	11					
	VACON0010-3L-0001-4-R02	0.5	0.37	1.3	MI1	66 x 160 x 99	2.60 x 6.30 x 3.90	0.55	1.21
	VACON0010-3L-0002-4-R02	0.75	0.55	1.9					
VACON0010-3L-0003-4-R02	1	0.75	2.4						
380-480 VAC, 3-phase	VACON0010-3L-0004-4-R02	1.5	1.1	3.3	MI2	90 x 195 x 102	3.54 x 7.68 x 4.02	0.7	1.54
	VACON0010-3L-0005-4-R02	2	1.5	4.3					
	VACON0010-3L-0006-4-R02	3	2.2	5.6					
	VACON0010-3L-0008-4-R02	5	3	7.6	MI3	100 x 255 x 109	3.94 x 10.04 x 4.29	0.99	2.18
	VACON0010-3L-0009-4-R02	6	4	9					
	VACON0010-3L-0012-4-R02	7.5	5.5	12					
	VACON0010-3L-0002-7-R02	1	0.75	1.7					
525-600 VAC, 3-phase	VACON0010-3L-0003-7-R02	2	1.5	2.7	MI3	100 x 255 x 109	3.94 x 10.04 x 4.29	0.99	2.18
	VACON0010-3L-0004-7-R02	3	2.2	3.9					
	VACON0010-3L-0006-7-R02	5	4	6.1					
	VACON0010-3L-0009-7-R02	7.5	5.5	9					

TYPE DESIGNATION CODE

VACON 0010 - 3L - 0009 - 4 + OPTION CODES

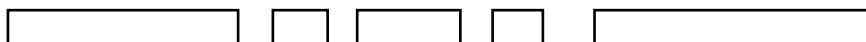

Product

Input phase

Current rating

Voltage rating

+ Options

I/O CONFIGURATION

Terminal	Description	Vacon 10
1	+10 V _{ref}	●
2	A11	●
3	GND	●
4	A12	0(4)-20mA
5	GND	●
6	24 V _{out}	●
7	GND/DIC*	GND
8	DI1	●
9	DI2	0-+30 V R _i = 12 kΩ
10	DI3	Cold Plate R _i = 4 kΩ
13	DOC	Digital output common
14	DI4	●
15	DI5	0-+30 V R _i = 12 kΩ
16	DI6	Cold Plate R _i = 4 kΩ
18	A0	Analogue output
20	D0	Open collector, max. load 48 V/50 mA
22	RO13-CM	●
23	RO14-NO	Relay output 1
24	RO22-NC	●
25	RO21-CM	Relay output 2
26	RO24-NO	●
A	A - RS485	Modbus RTU
B	B - RS485	Modbus RTU

* Selectable



MCA ADAPTER

PC INTERFACE AND PARAMETER COPYING

The MCA (Micro Communications Adapter) is a snap-on and intelligent copying unit for VACON 10.

- Parameter copying without main power in the drive
- Download settings directly to the MCA from PC without a drive
- HW interface for PC connection to the drive

Factory installed options code	Description
+EMC2	C2-Level EMC filter (includes +QPES)
+QPES	Cable shield grounding kit

Separately delivered options code	Description
ENC-IP21-M1x	IP21 cover M11-MI3. x=1,2,3
ENC-IN01-M1x	UL Type 1 Kit M11-MI3. x=1,2,3
VACON-ADP-MCAA	MCA RS-422 adapter w/ parameter copy
VACON-ADP-MCAA-KIT	Complete MCA + USB cable kit



IP21/UL TYPE 1 KIT

Mains connection	Input voltage U_{in}	110...120 V, -15 %...+10 % 1~ 208...240 V, -15 %...+10 % 1~ 208...240 V, -15 %...+10 % 3~ 380...480 V, -15 %...+10 % 3~ 575 V, -15 %...+10 % 3~
	Input frequency	45...66 Hz
	Connection to mains	Once per minute or less (normal case)
Motor connection	Output voltage	0... U_{in} (2 x U_{in} with 115 V drives)
	Output current	Continuous rated current I_N at rated ambient temperature overload 1.5 x I_N max. 1 min/10 min
	Starting current / Torque	Current 2 x I_N for 2 secs in every 20 sec period Torque depends on motor
	Output frequency	0...320 Hz
	Frequency resolution	0.01 Hz
Control characteristics	Control method	Frequency Control U/f. Open loop sensorless vector control
	Switching frequency	1.5...16 kHz; Factory default 4 kHz, (575 V model default 2 kHz)
	Braking torque	100 % x T_N with brake chopper in 3-phase version sizes MI2-3 30 % x T_N with DC-braking. Dynamic flux braking available in all types
Ambient conditions	Ambient operating temperature	-10°C (no frost)...+50°C: rated loadability I_N (1L-0009-2, 3L-0007-2, 3L-0011-2 and with options ENC-IP21-Mlx and ENC-IN01-Mlx ambient max +40°C)
	Storage temperature	-40°C...+70°C
	Altitude	100 % load capacity (no derating) up to 1000 m 1 % derating for each 100 m above 1000 m; max. 2000 m
	Enclosure class	M11-3:IP20
EMC	Immunity	Complies with EN61800-3 (2004)
	Emissions	208-240 V: EMC level C2: with an internal +EMC2 option 380-480 V: EMC level C2: with an internal +EMC2 option Note: All models ending in "-R02" are delivered as EMC4
Approvals	EN61800, C-Tick, Gost R, CB, CE, UL, cUL, IEC (not all versions, see unit nameplate for more detailed approvals)	

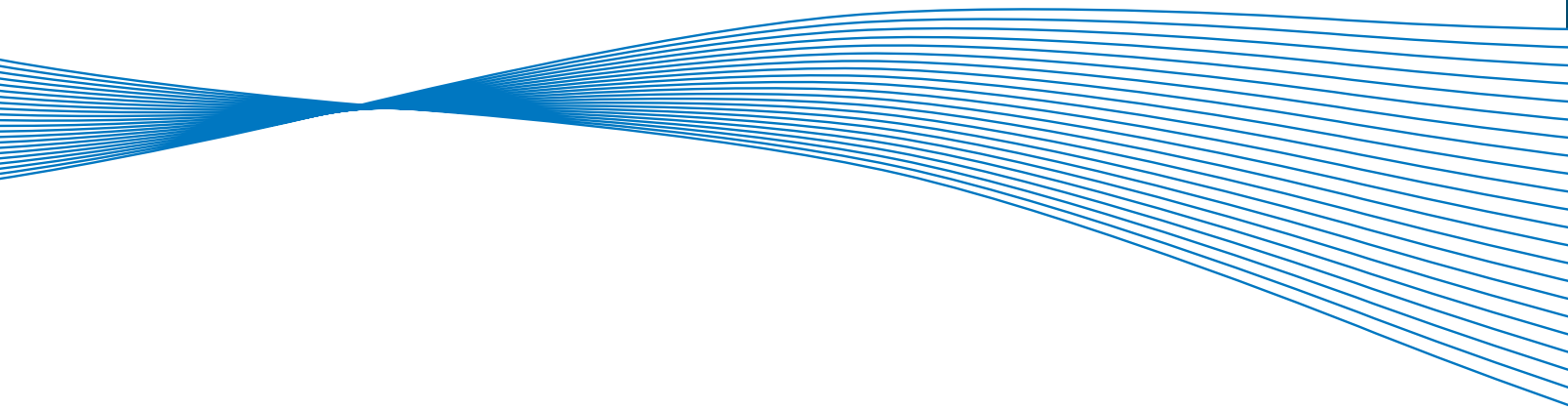

WE ARE DRIVES



VACON[®] 20





VACON® 20 – POSSIBILITIES AND PERFORMANCE

The VACON® 20 AC drive comes packed with functionality and possibilities to bring any machine control to a completely new level. The compact size in combination with a wide power range is the base, but the VACON® 20's possibilities do not end there. A built-in PLC functionality, which is one of the most flexible on the market, makes this product adapt to every task and bring cost savings to the user.

In order for machine builders to be able to compete in an increasingly competitive market, it is important to continuously seek solutions to further improve performance and cost efficiency – VACON® 20 offers new possibilities here.

WIDE POWER RANGE

The VACON® 20 is available in all common voltages in the range of 110-600V. Combined with a wide power range up to 18.5kW /25 HP. The VACON® 20 has something for customers all over the globe. Customers can reduce costs by implementing our harmonized product range and increase efficiency in their manufacturing processes. In currents above 16A the drive is available with a built-in harmonic filtering choke for public networks according to IEC61000-3-12.

CUTTING-EDGE PERFORMANCE

Machinery performance is very much dependent on the performance of the AC drive. In the VACON® 20 we have done our best to cut cycle times and maximize the control performance of the drive. The built-in RS-485 interface offers a cost effective and simple serial control interface for the drive. With optional modules, the Vacon 20 can be connected to almost any fieldbus system including CANOpen, DeviceNet and Profibus DP.

FAST INSTALLATION AND SET-UP

The VACON® 20 is designed for efficient volume manufacturing where every second in installation and configuration time counts. Easy access terminals, built-in DIN rail mounting and the MCA parameter copying tool which can clone settings without main power in the drive are all examples of features that help reduce start-up time.

WRITE CUSTOM APPLICATIONS USING VACON PROGRAMMING

The ability to customize functionality presents OEMs an opportunity to increase machine performance and save costs. The customer can build his own control logic in the drive and utilize unused I/O of the drive for performing other machine related tasks. In addition, the the parameter list can be freely modified and application specific parameter sets and default settings can be created. By utilizing the VACON Programming* PC Tool, VACON® 20 can help make better and more cost effective machine designs.

*Contact your local Vacon office for more information.

KEY BENEFITS:

- Fieldbus connectivity
- Parameter copying without main power
- Custom-made software possible

TYPICAL APPLICATIONS:

- Pumps & Fans
- Conveyors
- Packaging, processing and washing machines

TECHNICAL HIGHLIGHTS:

- Wide power range up to 25HP/18.5kW
- High performance and functionality
- Full I/O + option board support
- Fast installation and setup
- Optional Integral DC Choke available for MI4 - MI5



RATINGS AND DIMENSIONS

Supply voltage	AC drive type	Output Power and Current High Overload (150%)			Frame size	Dimensions W x H x D		Weight		
		HP	kW	I _N (A)		mm	inches	kg	lb	
110-120 VAC, 1-phase	VACON0020-1L-0001-1-R02	0.33	0.25	1.7	MI2	90 x 195 x 102	3.54 x 7.68 x 4.02	0.7	1.54	
	VACON0020-1L-0002-1-R02	0.5	0.37	2.4						
	VACON0020-1L-0003-1-R02	0.75	0.55	2.8						
	VACON0020-1L-0004-1-R02	1	0.75	3.7						
	VACON0020-1L-0005-1-R02	1.5	1.1	4.8						
208-240 VAC, 1-phase	VACON0020-1L-0001-2-R02	0.33	0.25	1.7	MI1	66 x 160 x 99	2.60 x 6.30 x 3.90	0.55	1.21	
	VACON0020-1L-0002-2-R02	0.5	0.37	2.4						
	VACON0020-1L-0003-2-R02	0.75	0.55	2.8						
	VACON0020-1L-0004-2-R02	1	0.75	3.7	MI2	90 x 195 x 102	3.54 x 7.68 x 4.02	0.7	1.54	
	VACON0020-1L-0005-2-R02	1.5	1.1	4.8						
	VACON0020-1L-0007-2-R02	2	1.5	7						
	VACON0020-1L-0009-2-R02	3	2.2	9.6						
208-240 VAC, 3-phase	VACON0020-3L-0001-2-R02	0.33	0.25	1.7	MI1	66 x 160 x 99	2.60 x 6.30 x 3.90	0.55	1.21	
	VACON0020-3L-0002-2-R02	0.5	0.37	2.4						
	VACON0020-3L-0003-2-R02	0.75	0.55	2.8						
	VACON0020-3L-0004-2-R02	1	0.75	3.7	MI2	90 x 195 x 102	3.54 x 7.68 x 4.02	0.7	1.54	
	VACON0020-3L-0005-2-R02	1.5	1.1	4.8						
	VACON0020-3L-0007-2-R02	2	1.5	7						
	VACON0020-3L-0011-2-R02	3	2.2	11						
	VACON0020-3L-0012-2-R02	-	3	12.5	MI3	100 x 255 x 109	3.94 x 10.04 x 4.29	0.99	2.18	
	VACON0020-3L-0017-2-R02	5	4	17.5						
	VACON0020-3L-0025-2-R02	7.5	5.5	25	MI4	165 x 370 x 165	6.5 x 14.6 x 6.5	8	18	
	VACON0020-3L-0031-2-R02	10	7.5	31						
	VACON0020-3L-0038-2-R02	15	11	38	MI5	165 x 414 x 202	6.5 x 16.3 x 8	10	22	
	VACON0020-3L-0001-4-R02	0.5	0.37	1.3						
380-480 VAC, 3-phase	VACON0020-3L-0002-4-R02	0.75	0.55	1.9	MI1	66 x 160 x 99	2.60 x 6.30 x 3.90	0.55	1.21	
	VACON0020-3L-0003-4-R02	1	0.75	2.4						
	VACON0020-3L-0004-4-R02	1.5	1.1	3.3						
	VACON0020-3L-0005-4-R02	2	1.5	4.3	MI2	90 x 195 x 102	3.54 x 7.68 x 4.02	0.7	1.54	
	VACON0020-3L-0006-4-R02	3	2.2	5.6						
	VACON0020-3L-0008-4-R02	5	3	7.6						
	VACON0020-3L-0009-4-R02	6	4	9	MI3	100 x 255 x 109	3.94 x 10.04 x 4.29	0.99	2.18	
	VACON0020-3L-0012-4-R02	7.5	5.5	12						
	VACON0020-3L-0016-4-R02	10	7.5	16						
	VACON0020-3L-0023-4-R02	15	11	23	MI4	165 x 370 x 165	6.5 x 14.6 x 6.5	8	18	
	VACON0020-3L-0031-4-R02	20	15	31						
	VACON0020-3L-0038-4-R02	25	18.5	38						
	525-600 VAC, 3-phase	VACON0020-3L-0002-7-R02	1	0.75	1.7	MI3	100 x 255 x 109	3.94 x 10.04 x 4.29	0.99	2.18
		VACON0020-3L-0003-7-R02	2	1.5	2.7					
		VACON0020-3L-0004-7-R02	3	2.2	3.9					
VACON0020-3L-0006-7-R02		5	4	6.1						
VACON0020-3L-0009-7-R02		7.5	5.5	9						

TYPE DESIGNATION CODE

VACON 0020 - 3L - 0009 - 4 + OPTION CODES

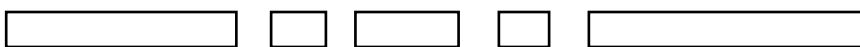

Product

Input phase

Current rating

Voltage rating

+ Options

I/O CONFIGURATION

VACON® 20

Terminal	Description	Vacon 20	
1	+10 V _{ref}	Maximum load 10 mA	●
2	AI1	0-10V	●
3	GND		●
4	AI2	0-10V / 0(4)-20mA*	●
5	GND		●
6	24 V _{out}	Max. 50 mA / CP 100 mA	●
7	GND/DIC*		●
8	DI1		●
9	DI2	0-+30 V R _i = 12 kΩ	●
10	DI3	Cold Plate R _i = 4 kΩ	●
13	DOC	Digital output common	●
14	DI4		●
15	DI5	0-+30 V R _i = 12 kΩ	●
16	DI6	Cold Plate R _i = 4 kΩ	●
18	AO	Analogue output	0-10V / 0(4)-20mA*
20	DO	Open collector, max. load 48 V/50 mA	●
22	RO13-CM	Relay output 1	●
23	RO14-NO		●
24	RO22-NC	Relay output 2	●
25	RO21-CM		●
26	RO24-NO		●
A	A-RS485	Modbus RTU	●
B	B-RS485	Modbus RTU	●

* Selectable



MCA ADAPTER



OPTION BOARD MOUNTING KIT

PC INTERFACE AND PARAMETER COPYING

The MCA (Micro Communications Adapter) is a snap-on and intelligent copying unit for Vacon 10 and Vacon 20 products.

- Parameter copying without main power in the drive
- Download settings directly to the MCA from PC without a drive
- HW interface for PC connection to the drive

Factory installed options code	Description	Suitability Vacon 20
+EMC2	C2-Level EMC filter (includes +QPES)	●
+QFLG	Flange mounting kit for MI4 and MI5	●



KEYPAD DOOR MOUNTING KIT

OPTIONS BOARDS

The Vacon 20 supports a wide range of option boards including Profibus DP, DeviceNet, CANOpen, as well as a wide range of I/O extension boards. Contact your Vacon partner for more information.

Separately delivered options code	Description
ENC-SLOT-MC03-13	Option board mounting kit Vacon 20 MI1-MI3
ENC-SLOT-MC03-45	Option board mounting kit Vacon 20 MI4-MI5
ENC-IP21-Mix	IP21 cover MI1-MI3. x=1,2,3
ENC-IN01-Mix	UL Type 1 Kit MI1-MI5. x=1,2,3,4,5
VACON-ADP-MCAA	MCA RS-422 adapter w/ parameter copy
VACON-ADP-MCAA-KIT	Complete MCA + USB cable kit
VACON-ADP-PASSIVE	Passive RS-422 adapter
VACON-PAN-HMDR-MC03	Complete keypad door mounting kit (3.0 m cable)
VACON-PAN-HMTX-MC06	Magnetic/Handheld keypad (1.0m cable)

*Requires VACON-ADP-PASSIVE



IP21/UL TYPE 1 KIT

Mains connection	Input voltage U_{in}	110...120 V, -15 %...+10 % 1~ 208...240 V, -15 %...+10 % 1~ 208...240 V, -15 %...+10 % 3~ 380...480 V, -15 %...+10 % 3~ 575 V, -15 %...+10 % 3~
	Input frequency	45...66 Hz
	Connection to mains	Once per minute or less (normal case)
Motor connection	Output voltage	0... U_{in} (2 x U_{in} with 115 V drives)
	Output current	Continuous rated current I_N at rated ambient temperature overload 1.5 x I_N max. 1 min/10 min
	Starting current / Torque	Current 2 x I_N for 2 secs in every 20 sec period Torque depends on motor
	Output frequency	0...320 Hz
	Frequency resolution	0.01 Hz
Control characteristics	Control method	Frequency Control U/f. Open loop sensorless vector control
	Switching frequency	1.5...16 kHz; Factory default 4 kHz, (575 V model default 2 kHz)
	Braking torque	100 % x T_N with brake chopper in 3-phase version sizes MI2-5 30 % x T_N with DC-braking. Dynamic flux braking available in all types
Ambient conditions	Ambient operating temperature	-10°C (no frost)...+50°C: rated loadability I_N (1L-0009-2, 3L-0007-2, 3L-0011-2 and with options ENC-IP21-Mix and ENC-IN01-Mix ambient max +40°C)
	Storage temperature	-40°C...+70°C
	Altitude	100 % load capacity (no derating) up to 1000 m 1 % derating for each 100 m above 1000 m; max. 2000 m
	Enclosure class	MI1-3:IP20, MI4-5:IP21, MI1 - MI5: UL Open Type
EMC	Immunity	Complies with EN61800-3 (2004)
	Emissions	208-240 V: EMC level C2: with an internal +EMC2 option 380-480 V: EMC level C2: with an internal +EMC2 option Note: All models ending in "-R02" are delivered as EMC4
Approvals	EN61800, C-Tick, Gost R, CB, CE, UL, cUL, IEC (not all versions, see unit nameplate for more detailed approvals)	

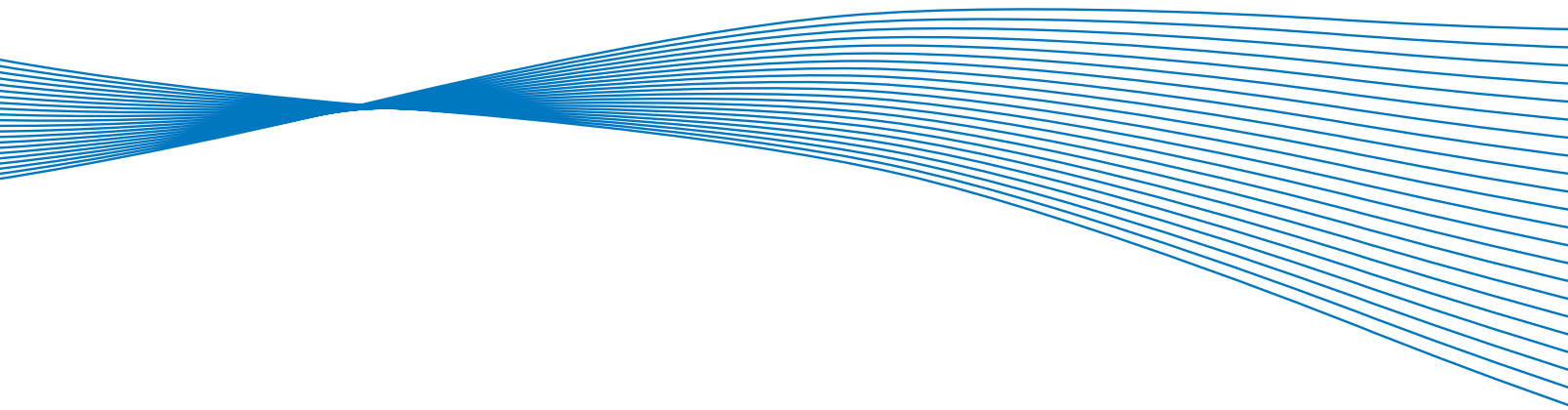

WE ARE DRIVES

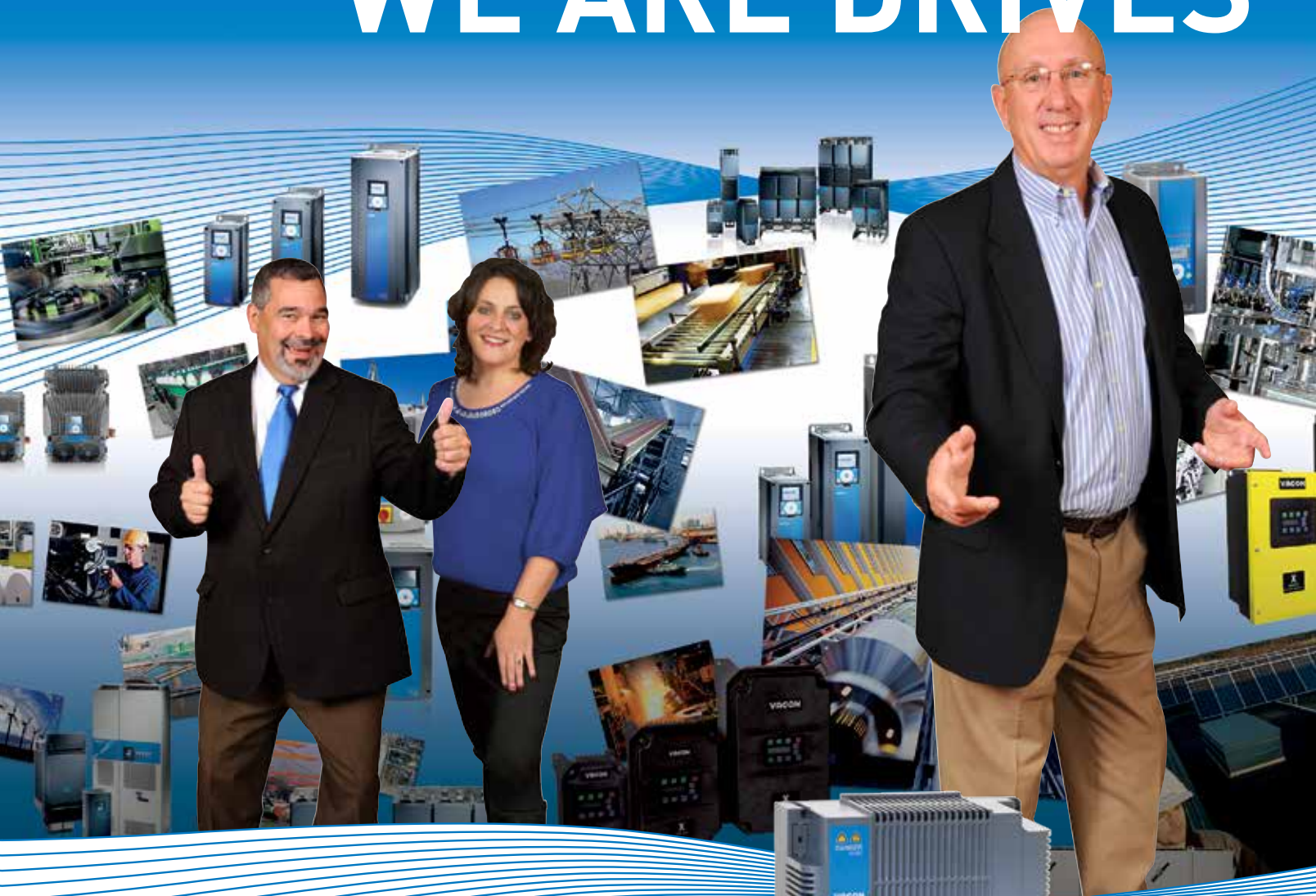

VACON[®] 20 COLD PLATE



VACON 20 COLD PLATE – FLEXIBILITY IN COOLING

AC drives are extremely energy efficient products; they do, however, still generate heat. The heat losses can sometimes limit the density of the machine design, especially if mounted in a sealed enclosure simply because there is no air circulation. The VACON® 20 Cold Plate design is based around a flat surface of the drive onto which the majority of the heat losses are concentrated. By attaching this surface to a cooling element, i.e. to the “cold plate”, the cooling of the drive can work even under the most demanding circumstances.

USE ANY COOLING MEDIA

As the cooling is done through a clear cooling interface, it is possible to use different cooling media depending on the situation. By attaching the drive to a heat sink with large cooling ribs, a fully passively cooled drive is created. As an alternative, the drive can be mounted on a plate, which is cooled by liquid in order to create a liquid cooled drive solution. Other possible cooling media include different types of refrigerants or metal constructions with a high heat energy conducting mass.

COMPACT SEALED ENCLOSURES

If the heat transport from the drive is not handled through air circulation, but through the heat being conducted out of the enclosure through a flat metal surface, the sealing of the enclosure is no longer a factor that significantly affects the cooling performance. It is thus possible to create and install the drive enclosure in environments with high amounts of dust and moisture. The VACON® 20 Cold Plate has a unique form that is designed to allow slim and flat enclosure solutions that can be highly integrated in the machine construction to be created.

DRIVE CUSTOMIZATION USING VACON PROGRAMMING

The VACON® 20 Cold Plate utilizes the advanced control concept of the VACON® 20 product family, offering full control performance and functionality. It also supports the built-in PLC functionality that allows the creation of application-specific software and solutions.

KEY BENEFITS:

- Highest cooling flexibility
- Fast plugging of I/O wiring
- Custom-made software possible

TYPICAL APPLICATIONS:

- Textile machinery
- Hoists and cranes
- Conveyors in demanding environment
- Compressors and heat pumps

TECHNICAL HIGHLIGHTS:

- Cold plate cooling
- Unique low depth design
- STO - Safe Torque Off according to SIL2
- High performance and functionality
- High ambient temperature rating up to 70°C

- Induction and PM motor support
- Integrated brake resistor
- Status LED's on drive
- Expansion slot for I/O or fieldbus
- Handheld text keypad with copy function
- Single plug I/O connector for OEMs



RATINGS AND DIMENSIONS

Supply voltage	AC drive type	Output Power and Current High Overload (150%)			Frame size	Dimensions W x H x D		Weight	
		HP	kW	I _N (A)		mm	inches	kg	lb
208-240 VAC, 1-phase	VACON0020-1L-0004-2-CP-R02	1	0.75	3.7	MS2	133 x 159 x 80	5.24 x 6.26 x 3.15	2	4.4
	VACON0020-1L-0005-2-CP-R02	1.5	1.1	4.8					
	VACON0020-1L-0007-2-CP-R02	2	1.5	7					
208-240 VAC, 3-phase	VACON0020-3L-0004-2-CP-R02	1.0	0.75	3.7	MS2	133 x 159 x 80	5.24 x 6.26 x 3.15	2	4.4
	VACON0020-3L-0005-2-CP-R02	1.5	1.1	4.8					
	VACON0020-3L-0007-2-CP-R02	2.0	1.5	7.0					
	VACON0020-3L-0011-2-CP-R02	3.0	2.2	11.0	MS3	161 x 240 x 83	6.34 x 9.45 x 3.27	3	6.6
	VACON0020-3L-0012-2-CP-R02	4.0	3.0	12.5					
	VACON0020-3L-0017-2-CP-R02	5.0	4.0	17.5					
	VACON0020-3L-0003-4-CP-R02	1	0.75	2.4					
380-480 VAC, 3-phase	VACON0020-3L-0004-4-CP-R02	1.5	1.1	3.3	MS2	133 x 159 x 80	5.24 x 6.26 x 3.15	2	4.4
	VACON0020-3L-0005-4-CP-R02	2	1.5	4.3					
	VACON0020-3L-0006-4-CP-R02	3	2.2	5.6					
	VACON0020-3L-0008-4-CP-R02	5	3.0	7.6	MS3	161 x 240 x 83	6.34 x 9.45 x 3.27	3	6.6
	VACON0020-3L-0009-4-CP-R02	6	4.0	9.0					
	VACON0020-3L-0012-4-CP-R02	7.5	5.5	12.0					
	VACON0020-3L-0016-4-CP-R02	10	7.5	16.0					

TYPE DESIGNATION CODE

VACON 0020 - 3L - 0009 - 4 - CP + OPTION CODES



Product Input phase Current rating Voltage rating Version + Options

I/O CONFIGURATION

Terminal	Description	Vacon 20 CP
1	+10 V _{ref}	Maximum Load 10 mA ●
2	AI1	0-10V 0-10V / 0(4)-20mA*
3	GND	●
4	AI2	0-10V / 0(4)-20mA* ●
5	GND	●
6	24 V _{out}	Max. 50 mA / CP 100 mA ●
7	GND/DIC*	●
8	DI1	●
9	DI2	0-+30 V R _i = 12 kΩ ●
10	DI3	Cold Plate R _i = 4 kΩ ●
13	DOC	Digital output common ●
14	DI4	●
15	DI5	0-+30 V R _i = 12 kΩ ●
16	DI6	Cold Plate R _i = 4 kΩ ●
18	AO	Analogue output 0-10V ●
20	DO	Open collector, max. load 48 V/50 mA ●
22	RO13-CM	●
23	RO14-NO	Relay output 1 ●
24	RO22-NC	●
25	RO21-CM	Relay output 2 ●
26	RO24-NO	●
A	A-RS485	Modbus RTU ●
B	B-RS485	Modbus RTU ●
	STO	Inputs S1, G1, S2, G2 Feedback F+/F- ●

* Selectable



Factory installed options code	Description
+EMC2	C2-Level EMC filter (includes +QPES)
+DBIR	Integrated cold plate brake resistor

OPTIONS BOARDS

The Vacon 20 Cold Plate products support a wide range of option boards including Profibus DP, DeviceNet, CANOpen, as well as a wide range of I/O extension boards. Contact your Vacon partner for more information.

Separately delivered options code	Description
CAB-USB/RS-485	USB cable only
VACON-PAN-HMDR-MC03	Complete keypad door mounting kit (3.0 m cable)
VACON-PAN-HMTX-MC06	Magnetic/Handheld keypad (1.0m cable)

Mains connection	Input voltage U_{in}	208...240 V, -15 %...+10 % 1- 208...240 V, -15 %...+10 % 3- 380...480 V, -15 %...+10 % 3-
	Input frequency	45...66 Hz
	Connection to mains	Once per minute or less (normal case)
Motor connection	Output voltage	0... U_{in}
	Output current	Continuous rated current I_N at rated ambient temperature overload $1.5 \times I_N$ max. 1 min/10 min
	Starting current / Torque	Current $2 \times I_N$ for 2 secs in every 20 sec period Torque depends on motor
	Output frequency	0...320 Hz
	Frequency resolution	0.01 Hz
Control characteristics	Control method	Frequency Control U/f. Open loop sensorless vector control
	Switching frequency	1.5...16 kHz; Factory default 4 kHz, (575 V model de- fault 2 kHz) Cold Plate models 6 kHz
	Braking torque	100 % $\times T_N$ with brake chopper in 3-phase version sizes MS2-3 30 % $\times T_N$ with DC-braking. Dynamic flux braking available in all types
Ambient conditions	Ambient operating temperature	Cold Plate models -10°C...+70°C
	Storage temperature	-40°C...+70°C
	Altitude	100 % load capacity (no derating) up to 1000 m 1 % derating for each 100 m above 1000 m; max. 2000 m Cold Plate max 3000 m
	Enclosure class	Cold Plate: IP00
EMC	Immunity	Complies with EN61800-3 (2004)
	Emissions	208-240 V: EMC level C2: with an internal +EMC2 option 380-480 V: EMC level C2: with an internal +EMC2 option NOTE: All models with "-R02" are delivered as EMC4.
Approvals	EN61800, C-Tick, Gost R, CB, CE, UL, cUL, IEC (not all versions, see unit nameplate for more detailed approvals)	

VACON® 20
COLD PLATE

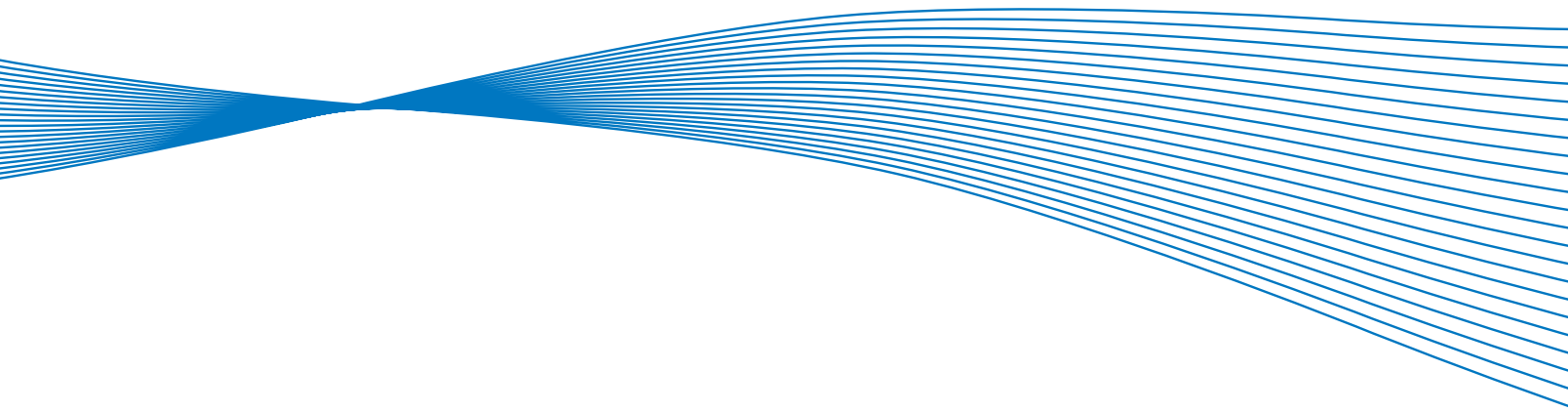

WE ARE DRIVES



VACON[®] 20 X



VACON® 20 X — PERFORMANCE UNDER PRESSURE

VACON 20 X sees Vacon building on its experience of producing high class enclosures drives to offer a decentralized drive solution with countless possibilities. An IP66/Type 4X enclosure offers the best possible protection from any factors that may be encountered in harsh environments, while other great features such as large cooling ribs and an integral mains switch option make VACON 20 X the right choice when your drive needs to be integrated directly into the application.

EVERYTHING IN ONE PLACE

Despite its highly developed enclosure, VACON 20 X remains a masterpiece in easy installation and commissioning. If you're looking for a decentralized solution, chances are that space is at a premium. VACON 20 X has all the standard features, like Safe Torque Off, you would expect along with a wide range of options all in one place. The option of having a built-in main switch is a great saver when it comes to installation costs – the drive provides the housing for the switch and makes the drive work in the field to full effect. With all of this on-board functionality, VACON 20 X is the only piece of equipment you need.

IP66/TYPE 4X CERTIFIED PROTECTION

VACON 20 X comes with an enclosure that is compliant with IP66 and UL Type 4X requirements, offering the best possible protection against external issues. This protection is essential in moist or dusty conditions, where dust could otherwise build up through airflow and cause internal components to fail. The enclosure is certified 3M6, IEC 60068-2 resistant to 2g vibrations and the rubber sealing comes equipped with a GORE® protective Snap-in Vent (Membrane IP69K). This ensures the pressure inside the drive is equalized with the surrounding environment, which in turn prevents the sealing from being worn down.

TECHNICAL HIGHLIGHTS

- 2g resistance to vibrations
- IP66/Type 4X enclosure
- Large cooling ribs
- Integral mains switch option
- Safe Torque Off (STO) mode according to SIL3
- Runs induction and permanent magnet motors
- Integrated PID controller
- Wide amount of fieldbus connections
- Built-in EMC filter for category level C2.
- Brake chopper integrated

BENEFITS

- Cost savings from decentralized concept
- Can be used in almost any environment
- Custom-made software solutions with built-in PLC functionality for OEMs
- Mountable in any position; fits into any available space

TYPICAL APPLICATIONS

- Machinery
- Pumps
- Conveyors
- Fans
- Washdown duty installations
- General purpose installations



RATINGS & DIMENSIONS

Supply voltage	AC drive type	Output Power and Current High Overload (150%)			Frame size	Dimensions W x H x D		Weight	
		HP	kW	I _N [A]		mm	inches	kg	lb
208-240 VAC, 1-phase	VACON0020-1L-0004-2-X-R02	1	0.75	3.7	MU2	169 x 295 x 154	6.65 x 11.61 x 6.06	3.4	7.50
	VACON0020-1L-0005-2-X-R02	1.5	1.1	4.8					
	VACON0020-1L-0007-2-X-R02	2	1.5	7					
208-240 VAC, 3-phase	VACON0020-3L-0004-2-X-R02	1.0	0.75	3.7	MU2	169 x 295 x 154	6.65 x 11.61 x 6.06	3.4	7.50
	VACON0020-3L-0005-2-X-R02	1.5	1.1	4.8					
	VACON0020-3L-0007-2-X-R02	2.0	1.5	7.0					
	VACON0020-3L-0011-2-X-R02	3.0	2.2	11.0	MU3	205 x 375 x 180	8.07 x 14.76 x 7.09	6	13.23
	VACON0020-3L-0012-2-X-R02	4.0	3.0	12.5					
	VACON0020-3L-0017-2-X-R02	5.0	4.0	17.5					
380-480 VAC, 3-phase	VACON0020-3L-0003-4-X-R02	1.0	0.75	2.4	MU2	169 x 295 x 154	6.65 x 11.61 x 6.06	3.4	7.50
	VACON0020-3L-0004-4-X-R02	1.5	1.1	3.3					
	VACON0020-3L-0005-4-X-R02	2.0	1.5	4.3					
	VACON0020-3L-0006-4-X-R02	3.0	2.2	5.6					
	VACON0020-3L-0008-4-X-R02	5.0	3.0	7.6	MU3	205 x 375 x 180	8.07 x 14.76 x 7.09	6	13.23
	VACON0020-3L-0009-4-X-R02	6.0	4.0	9.0					
	VACON0020-3L-0012-4-X-R02	7.5	5.5	12.0					
	VACON0020-3L-0016-4-X-R02	10.0	7.5	16.0					

TYPE DESIGNATION CODE

VACON 0020 - 3L - 0009 - 4 - X + OPTION CODES



Product

Input phase

Current rating

Voltage rating

Version

+ Options

WHAT'S INSIDE VACON® 20 X

REMOVABLE KEYPAD AS OPTION

Vacon's removable text keypad has non-volatile memory (for copy/paste parameter settings). Mounted with a magnetic fixing, it can be removed and mounted next to the drive or used remotely during commissioning.

IP66/UL TYPE 4X CERTIFIED PROTECTION

VACON 20 X has an enclosure that is IP66/UL Type 4X approved, meaning that the drive is resistant to potential hazards such as moisture, dust, detergents and fluctuations in temperature.

MAINS SWITCH INTEGRATED AS OPTION

Using the integrated drive supply switch option, the drive's main supply can be disconnected and locked for safety during maintenance work. This also saves on investment costs and space.

GORE® VENT

The GORE® vent allows the enclosure to breathe, no matter how harsh the external conditions, acting as a barrier against condensation, dust and dirt. It equalizes the pressure inside the drive with the surrounding environment, which is vital in preventing the sealing from getting worn down.

EXPANSION SLOT FOR ADDITIONAL OPTION BOARDS

An expansion slot opens up the possibility of connecting to other fieldbuses and I/O boards.

PROGRAMMING DESIGNED FOR OEMS

Built-in PLC functionality, using IEC61131-1 programming methods, allows software logic and parameter list definitions to be modified with the optional VACON® Programming Tool.



I/O CONNECTIONS

Standard I/O		
Terminal		Signal
A	RS485	Differential receiver/transmitter
B	RS485	Differential receiver/transmitter
1	+10V _{ref}	Reference output
2	AI1+	Analog input 1, voltage or current
3	AI1- /GND	Analog input 1 common
4	AI2+	Analog input 2, voltage or current
5	AI2- /GND	Analog input 2 common
6	24V _{out}	24 V aux. voltage
7	GND / DIC	I/O ground
8	DI1	Digital input 1
9	DI2	Digital input 2
10	DI3	Digital input 3
13	GND	I/O ground
14	DI4	Digital input 4
15	DI5	Digital input 5
16	DI6	Digital input 6
18	AO1+	Analog output signal (+output), voltage
20	DO1	Digital output (open collector)

OPTIONS

Keypad	
VACON-PAN-HMTX-MC06X	Magnetic Handheld keypad
+QDSS	Drive Supply Switch
+QDSH	Simple Operating Panel w/ Drive Supply Switch

Relays		STO connections		
Terminal		Terminal		
22	R01/2 CM	Relay output 1	S1	Isolated digital output 1
23	R01/3 NO		G1	
24	R02/1 NC	Relay output 2	S2	Isolated digital output 2
25	R02/2 CM		G2	
26	R02/3 NO		F+	STO feedback
		F-		

OPTION BOARDS

Option boards	
OPT-B1-V	6 x DI/DO, each digital input can be individually programmed to also act as digital output
OPT-B2-V	2 x Relay output + Thermistor
OPT-B4-V	1 x AI, 2 x AO (isolated)
OPT-B5-V	3 x Relay output
OPT-B9-V	1 x RO, 5 x DI (42-240 VAC)
OPT-BF-V	1 x AO, 1 x DO, 1 x RO
OPT-E3-V	Profibus DPV1, (screw connector)
OPT-E5-V	Profibus DPV1, (D9 connector)
OPT-E6-V	CANopen
OPT-E7-V	DeviceNet
OPT-EC-V	EtherCat
OPT-CI-V	Modbus TCP/IP
OPT-CJ-V	BACnet MS/TP
OPT-CP-V	Profinet I/O
OPT-CQ-V	Ethernet/IP

GENERAL

Communication	RS485	Standard: Modbus RTU
	HMI	RS422 based for PC tools or Keypad interface
Software features	Control characteristics	Induction and PMSM motor control Switching frequency up to 16 kHz (factory default 6 kHz) Frequency control U/f and Open loop sensorless vector control Motor tuning identification and flying start mode
Motor connection	Output voltage	0...U _{in}
	Output current	Continuous rated current I _n at rated ambient temperature Overload 1.5 x I _n max 1 min / 10 min
	Starting current / torque	Current 2 x I _n for 2 secs every 20 sec period
	Output frequency	0...320 Hz - resolution 0.01 Hz
Ambient conditions	Ambient operating temperature	-10 °C...+40 °C without derating (max. temperature 50°C with derating)
	Vibration	2g resistance to vibrations (according to 3M6/IEC 60068-2)
	Altitude	100% load capacity (no derating) up to 1000 m; 1% derating every 100 m up to 3000 m
Enclosure class		IP66 / Type 4X
EMC	Immunity	Complies with EN 61800-3, level C2
	Emissions	NOTE: All models with "-R02" are delivered as EMC4.
Functional safety	Safe Torque Off (STO)	SIL 3 according to IEC61800-5-2 PL e / Cat 4 according to ISO13849-1

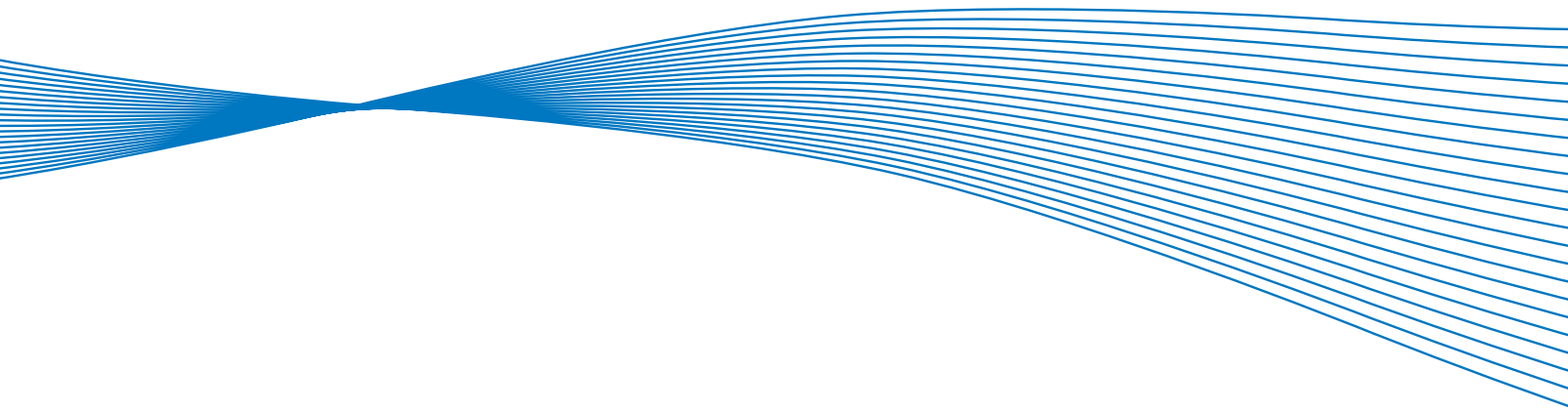

WE ARE DRIVES



VACON[®] 100



EXCEEDING EXPECTATIONS

It may look like a traditional AC drive - but it's not. VACON® 100 is bursting with smart new features. Benefit from functional safety with Safe Torque Off to prevent the motor from generating torque on the motor shaft, Safe Stop 1, and ATEX certified motor over-temperature protection. VACON 100 also has a unique feature with built-in Ethernet to make integration to plant automation easy and efficient via integrated ModBus TCP, Ethernet I/P or Profinet IO.

VACON 100 is ideal for a wide range of constant power/torque applications including pumps, fans, compressors and conveyors. These are applications where energy efficiency and productivity improvements often result in a rapid return on project investments.

In addition to several standard features such as built-in I/Os with 3 option slots, integrated RS485 and Ethernet based fieldbus support, varnished boards and robust motor control features for reliability, the VACON 100 also has dedicated features for each of these key applications. VACON 100 is available in the power range of 0.55 to

90 kW (0.75 - 125 HP) 230 V and 1.1-160 kW (1.5 - 200 HP) 500 V. The wall-mountable drive modules are easy to install and operate, with IP21/UL Type1 provided as standard. Options include IP54/UL Type12 and flange [through hole] mounting. Frame sizes MR8 and MR9 are also available as compact IP00 for easy installation to cabinets or enclosures.

VACON 100 allows you to do much more than you would expect from a standard drive. At Vacon, we aim to exceed your expectations.

TYPICAL APPLICATIONS

Process industry

- Conveyors
- Pumps & fans
- Chippers, debarking drums, sawmills

Marine

- Cargo pumps, compressors
- Steering gear

Industrial HVAC/ Semiconductor industry

- Compressors
- Pumps & fans

Water

- Distribution
- Desalination
- Treatment
- Pumps, compressors, conveyors

Chemical, Oil & Gas

- Pumps & fans
- Compressors

Mining & Minerals

- Conveyors
- Pumps & fans

Cement auxiliary drives

- Conveyors
- Pumps & fans



WHAT'S IN IT FOR YOU

VACON 100	Common features	Benefits
	Compliance with global standards	Global compatibility.
	Built-in Modbus TCP and Modbus RTU Profinet IO or Ethernet/IP as software option	Most of what is needed is in-built. Easy integration with plant automation.
	Safe torque off, Safe Stop and ATEX	Improved safety at work.
	EMC compliance with integrated RFI filter. Integrated DC chokes	No additional accessories required
	Conformal coating Compact IP54/ UL Type 12 with same footprint as IP21/UL Type 1 Flange mounting Side by side mounting for IP54/ UL Type 12	High reliability in difficult environments, easy and cost effective installation.
	Standard I/O + 3 free slots Fieldbus options, Built in PLC capability	Reduces need for an external controller.
	High efficiency >97% + energy optimisation Energy counter Real time clock with calendar based functions Optimized control of cooling fan	Fast investment payback, increase profits. Easy monitoring of energy savings. Reduce noise levels.
	Dedicated features	Added benefits
• Pumps	2 PID controllers with Sleep Mode Soft Fill , Jockey Pump, Pump Autoclean PM and induction motor support	Demand based optimization of the process for accurate process control and energy saving. Easy selection for any motor. PM motor allows higher power density, less mechanics.
• Fans	Flying start, Motor Switch 3 Prohibit Frequency Ranges PM and induction motor support	Save time during process operation and maintenance. Fan lifetime increased due to reduced mechanical stress. Easy selection for any motor. PM motor allows higher power density= energy savings
• Compressors	IP21/UL Type 1 and IP54/ UL Type 12 Flange (through hole) mounting IP00 for MR8 and MR9	Suitable for wide installation needs. Easy to integrate into the machine, saving space and cost of integration and cooling.
• Conveyors	Load drooping, Identification run without disconnecting the motor from the load, mechanical brake, torque boost	Avoid stress on mechanics. Easy commissioning.

SMART INTEGRATION TO YOUR PLANT AUTOMATION

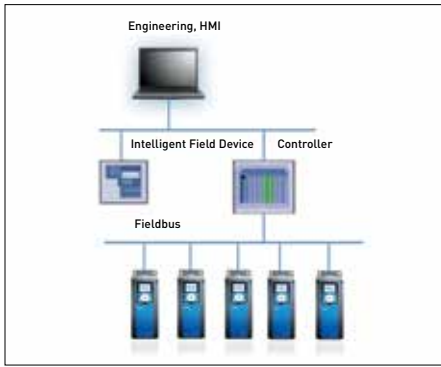

FIELDBUS OPTIONS

VACON® 100 is easily integrated with your plant's automation system using built-in Modbus RTU (RS485) or Modbus TCP (Ethernet). Integration over Profinet IO or Ethernet IP systems is made possible through software options. Click-in fieldbus options facilitate integration to traditional systems using Profibus DP, DeviceNet, CANOpen & LONWorks. Fieldbus technology ensures increased control and monitoring of the process equipment with reduced cabling.

Standard: Modbus RTU, BACNet MSTP, Metasys N2
Option Cards: Profibus DP, DeviceNet, LONWorks, CANOpen

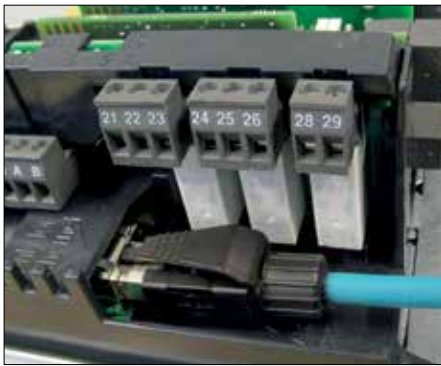

BUILT-IN ETHERNET

Ethernet based communication is common in all process industries today and VACON 100 is an obvious economical choice. No additional options or gateways are needed for the communication with process automation due to its unique built-in Ethernet. It not only provides access for commissioning and maintenance through VACON® Live but also makes local or remote wireless monitoring possible.

Standard: Modbus TCP, BACNet IP
Included in -R02: ProfinetIO, Ethernet IP

VACON® 100

FUNCTIONAL SAFETY

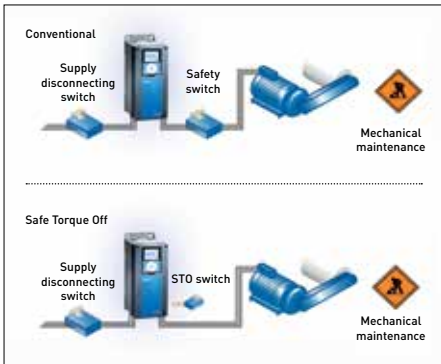

SAFE TORQUE OFF, SAFE STOP 1*

Safe Torque Off (STO) prevents the drive from generating torque on the motor shaft and prevents unintentional start-ups. The function also corresponds to an uncontrolled stop in accordance with stop category 0, EN60204-1. Safe Stop 1 (SS1) initiates motor deceleration and initiates the STO function after an application specific time delay. The function also corresponds to a controlled stop in accordance with stop category 1, EN 60204-1.

The advantage of the integrated STO and SS1 safety options compared to standard safety technology using electromechanical switchgear is the elimination of separate components and the effort required to wire and service them, while still maintaining the required level of safety at work.

* Requires OPT-BJ-V Option Card

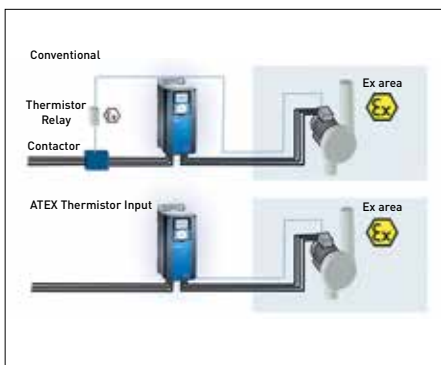

ATEX CERTIFIED THERMISTOR INPUT*

Vacon has developed an ATEX approved thermistor input, as an integrated option. Certified and compliant with the European ATEX directive, 94/9/EC, the integrated thermistor input is specially designed for the temperature supervision of motors that are placed in areas in which potentially explosive gas, vapor, mist or air mixtures are present and areas with combustible dust. Typical industries requiring such supervision include chemical, petrochemical, marine, metal, mechanical, mining, and oil drilling. If over-heating is detected, the drive immediately stops feeding energy to the motor. As no external components are needed, the cabling is kept to a minimum, improving reliability and saving on both space and costs.

* Requires OPT-BJ-V Option Card

USER FRIENDLY KEYPAD

Vacon has ensured that the user interface is simple and intuitive to use. You will enjoy the keypad's well-structured menu system that allows for fast commissioning and trouble-free operation.

- Graphical and text keypad with multiple language support
- 9 signals can be monitored at the same time on a single multimonitor page and is configurable to either 9,6 or 4 signals
- 3 color LED status indication on the control unit:
 - **blinking green** = ready; **green** = run; **red** = fault
- Trend display for two signals at the same time



QUICK SET UP

Easy commissioning tools ensure a hassle-free set up whatever the application. Easy diagnostic with help in plain text is provided for each parameter, signal and fault.

- Startup Wizard** — for fast setup of basic pump or fan applications
- PID Mini-Wizard** — for easy commissioning of internal PID Controller
- Multi-Pump Wizard** — for easy commissioning of Multi-Pump system
- Fire Mode Wizard** — for easy commissioning of Fire Mode function

VACON® 100 also features a real time clock with calendar based functions.



VACON® 100

EASY INSTALLATION

Both IP21/UL Type 1 and IP54/UL Type 12 units have the same footprint making either an easy choice. Compact IP54/UL Type12 units can be installed side by side and require no additional space between them. Frame size MR8 and MR9 are available as IP00 for cabinet installation. Our flange mounting option makes through-hole mounting in the enclosure possible, with the heat sink remaining outside the enclosure. This significantly reduces heat losses in the enclosure and thus the enclosure size. Likewise, integrated lead-in grommets and 360 degree grounding improve both the IP54/UL Type 12 and EMC respectively, and lead to further cost savings.



DRIVE CUSTOMIZER

VACON 100 comes equipped with a built-in functionality that enables the drive to adapt to almost any function requiring I/O and control logic. The drive customizer function features a wide array of logical and numerical function blocks that can combine and extend standard drive functionalities, ensuring specific user requirements are met. The drive customizer does not require any special tools or training, while a fully graphical configuration can be performed using our own configuration tool, VACON® Live. Configurations can be copied using VACON Live as part of the normal parameter list.

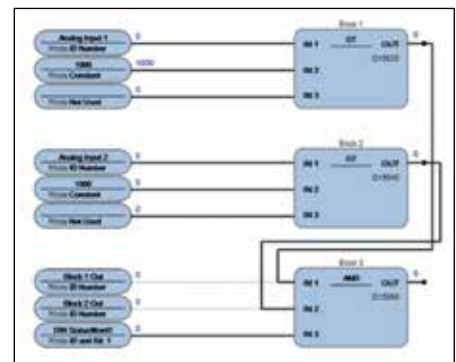

RATINGS & DIMENSIONS

MAINS VOLTAGE 208—240 V, 50/60 HZ, 3~

Vacon 100	Output Power and Current						Frame Size	Dimensions WxHxD (mm) WxHxD (inch)	Weight (kg) Weight (lbs)
	High Overload (150%)			Low Overload (120%)					
	HP	kW	Amps	HP	kW	Amps			
VACON 0100-3L-0003-2-R02	0.5	0.37	2.6	0.75	0.55	3.7	MR4	128x328x190 5x12.9x7.5	6.0 13.0
VACON 0100-3L-0004-2-R02	0.75	0.55	3.7	1.0	0.75	4.8			
VACON 0100-3L-0007-2-R02	1.0	0.75	4.8	1.5	1.1	6.6			
VACON 0100-3L-0008-2-R02	1.5	1.1	6.6	2.0	1.5	8.0			
VACON 0100-3L-0011-2-R02	2.0	1.5	8.0	3.0	2.2	11.0			
VACON 0100-3L-0012-2-R02	3.0	2.2	9.6	4.0	3.0	12.5			
VACON 0100-3L-0018-2-R02	4.0	3.0	12.5	5.0	4.0	18.0	MR5	144x419x214 5.7x16.5x8.4	10.0 22.0
VACON 0100-3L-0024-2-R02	5.0	4.0	18.0	7.5	5.5	24.0			
VACON 0100-3L-0031-2-R02	7.5	5.5	25.0	10.0	7.5	31.0			
VACON 0100-3L-0048-2-R02	10.0	7.5	31.0	15.0	11.0	48.0	MR6	195x557x229 7.7x21.9x9	20.0 44.0
VACON 0100-3L-0062-2-R02	15.0	11.0	48.0	20.0	15.0	62.0			
VACON 0100-3L-0075-2-R02	20.0	15.0	62.0	25.0	18.5	75.0	MR7	237x660x259 9.3x26x10.2	37.5 83.0
VACON 0100-3L-0088-2-R02	25.0	18.5	75.0	30.0	22.0	88.0			
VACON 0100-3L-0105-2-R02	30.0	22.0	88.0	40.0	30.0	105.0			
VACON 0100-3L-0140-2-R02	40.0	30.0	114.0	50.0	37.0	140.0	MR8	290x966x343 11.4x38x13.5	66.0 145.5
VACON 0100-3L-0170-2-R02	50.0	37.0	140.0	60.0	45.0	170.0			
VACON 0100-3L-0205-2-R02	60.0	45.0	170.0	75.0	55.0	205.0			
VACON 0100-3L-0261-2-R02	75.0	55.0	211.0	100.0	75.0	261.0	MR9	480x1150x365 18.9x45.3x14.4	108.0 238.0
VACON 0100-3L-0310-2-R02	100.0	75.0	251.0	125.0	90.0	310.0			
VACON 0100-3L-0140-2-R02+IP00	40.0	30.0	114.0	50.0	37.0	140.0	MR8 IP00	290x794x343 11.4x31.3x13.5	62.0 136.7
VACON 0100-3L-0170-2-R02+IP00	50.0	37.0	140.0	60.0	45.0	170.0			
VACON 0100-3L-0205-2-R02+IP00	60.0	45.0	170.0	75.0	55.0	205.0			
VACON 0100-3L-0261-2-R02+IP00	75.0	55.0	211.0	100.0	75.0	261.0	MR9 IP00	480x970x365 18.9x38.2x14.4	97.0 213.8
VACON 0100-3L-0310-2-R02+IP00	100.0	75.0	251.0	125.0	90.0	310.0			

* For all VACON 100 drives, overloadability is defined as follows: High: 1.5 x IH (1 min/10 min) @ 50°C; Low: 1.1 x IL (1 min/10 min) @ 40°C; IS for 2 sec.

MAINS VOLTAGE 380—500 V, 50/60 HZ, 3~

Vacon 100	Output Power and Current						Frame Size	Dimensions WxHxD (mm) WxHxD (inch)	Weight (kg) Weight (lbs)
	High Overload (150%)			Low Overload (120%)					
	HP	kW	Amps	HP	kW	Amps			
VACON 0100-3L-0003-5-R02	1.0	0.75	2.6	1.5	1.1	3.4	MR4	128x328x190 5x12.9x7.5	6.0 13.0
VACON 0100-3L-0004-5-R02	1.5	1.1	3.4	2.0	1.5	4.8			
VACON 0100-3L-0005-5-R02	2.0	1.5	4.3	3.0	2.2	5.6			
VACON 0100-3L-0008-5-R02	3.0	2.2	5.6	4.0	3.0	8.0			
VACON 0100-3L-0009-5-R02	4.0	3.0	8.0	5.0	4.0	9.6			
VACON 0100-3L-0012-5-R02	5.0	4.0	9.6	7.5	5.5	12.0			
VACON 0100-3L-0016-5-R02	7.5	5.5	12.0	10.0	7.5	16.0	MR5	144x419x214 5.7x16.5x8.4	10.0 22.0
VACON 0100-3L-0023-5-R02	10.0	7.5	16.0	15.0	11.0	23.0			
VACON 0100-3L-0031-5-R02	15.0	11.0	23.0	20.0	15.0	31.0			
VACON 0100-3L-0038-5-R02	20.0	15.0	31.0	25.0	18.5	38.0	MR6	195x557x229 7.7x21.9x9	20.0 44.0
VACON 0100-3L-0046-5-R02	25.0	18.5	38.0	30.0	22.0	46.0			
VACON 0100-3L-0061-5-R02	30.0	22.0	46.0	40.0	30.0	61.0			
VACON 0100-3L-0072-5-R02	40.0	30.0	61.0	50.0	37.0	72.0	MR7	237x660x259 9.3x26x10.2	37.5 83.0
VACON 0100-3L-0087-5-R02	50.0	37.0	72.0	60.0	45.0	87.0			
VACON 0100-3L-0105-5-R02	60.0	45.0	87.0	75.0	55.0	105.0			
VACON 0100-3L-0140-5-R02	75.0	55.0	105.0	100.0	75.0	140.0	MR8	290x966x343 11.4x38x13.5	66.0 145.5
VACON 0100-3L-0170-5-R02	100.0	75.0	140.0	125.0	90.0	170.0			
VACON 0100-3L-0205-5-R02	125.0	90.0	170.0	150.0	110.0	205.0			
VACON 0100-3L-0261-5-R02	150.0	110.0	205.0	200.0	132.0	261.0	MR9	480x1150x365 18.9x45.3x14.4	108.0 238.0
VACON 0100-3L-0310-5-R02	200.0	132.0	251.0	250.0	160.0	310.0			
VACON 0100-3L-0140-5-R02+IP00	75.0	55.0	105.0	100.0	75.0	140.0	MR8 IP00	290x794x343 11.4x31.3x13.5	62.0 136.7
VACON 0100-3L-0170-5-R02+IP00	100.0	75.0	140.0	125.0	90.0	170.0			
VACON 0100-3L-0205-5-R02+IP00	125.0	90.0	170.0	150.0	110.0	205.0			
VACON 0100-3L-0261-5-R02+IP00	150.0	110.0	205.0	200.0	132.0	261.0	MR9 IP00	480x970x365 18.9x38.2x14.4	97.0 213.8
VACON 0100-3L-0310-5-R02+IP00	200.0	132.0	251.0	250.0	160.0	310.0			

* For all VACON 100 drives, overloadability is defined as follows: High: 1.5 x IH (1 min/10 min) @ 50°C; Low: 1.1 x IL (1 min/10 min) @ 40°C; IS for 2 sec.

TYPE CODE KEY

VACON 0100 - 3L - 0009 - 5 + OPTION CODES

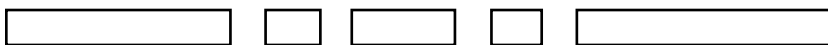

Product Input phase Current rating Voltage rating + Options

Basic I/O board		
Terminal		Signal
1	+10 V _{ref}	Reference output
2	AI1+	Analog input, voltage or current
3	AI1-	Analog input common (current)
4	AI2+	Analog input, voltage or current
5	AI2-	Analog input common (current)
6	24 V _{out}	24 V aux. voltage
7	GND	I/O ground
8	DI1	Digital input 1
9	DI2	Digital input 2
10	DI3	Digital input 3
11	CM	Common A for DI1-DI6
12	24 V _{out}	24 V aux. voltage
13	GND	I/O ground
14	DI4	Digital input 4
15	DI5	Digital input 5
16	DI6	Digital input 6
17	CM	Common A for DI1-DI6
18	A01+	Analog signal (+output)
19	A0-/GND	Analog output common
30	+24 V _{in}	24 V auxiliary input voltage
A	RS485	Differential receiver/transmitter
B	RS485	Differential receiver/transmitter

Standard relay board			Optional relay board *		
Terminal		+SBF3	Terminal		+SBF4
21	R01/1 NC	Relay output 1	21	R01/1 NC	Relay output 1
22	R01/2 CM		22	R01/2 CM	
23	R01/3 NO		23	R01/3 NO	
24	R02/1 NC	Relay output 2	24	R02/1 NC	Relay output 2
25	R02/2 CM		25	R02/2 CM	
26	R02/3 NO		26	R02/3 NO	
32	R03/1 CM	Relay output 3	28	TI1+	Thermistor input
33	R03/2 NO		29	TI1-	

* Standard relay board SBF3 (3XR0) can be replaced by SBF4 (2 x RO + Thermistor)

Option boards (all boards are varnished)		Option slot		
		C	D	E
OPT-B1-V	6 x DI/DO, each I/O can be individually programmable as input or output	●	●	●
OPT-B2-V	2 x Relay output + Thermistor	●	●	●
OPT-B4-V	1 x AI, 2 x AO (isolated)	●	●	●
OPT-B5-V	3 x Relay output	●	●	●
OPT-B9-V	1 x RO, 5 x DI (42-240 VAC)	●	●	●
OPT-BF-V	1 x AO, 1 x DO, 1 x RO	●	●	●
OPT-BH-V	3 x Temperature measurement (support for PT100, PT1000, NI1000, KTY84-130, KTY84-150, KTY84-131 sensors)	●	●	●
OPT-BJ-V	Safe torque-off, ATEX thermistor input, Safe Stop 1	-	-	●
OPT-E3-V	Profibus DPV1 (Screw connector)	-	●	●
OPT-E5-V	Profibus DPV1 (D9 connector)	-	●	●
OPT-E6-V	CANopen	-	●	●
OPT-E7-V	DeviceNet	-	●	●
OPT-F3-V	Replacement Board: 3 x Relay Output			
OPT-F4-V	Replacement Board: 2 x Relay Output + Thermistor			

Factory Installed Options	Description
+SBF4	2 x Ro + Thermistor (Replaces 3 relay standard board)
+IP54	IP54 / UL Type 12
+IP00	IP00 (for MR8 and MR9)
+SRBT	Real-time clock battery
+HMTX	Text keypad
+HMPA	Panel adapter (Dummy Keypad)
+S_B1	6 x DI/DO
+S_B2	2 x RO + Thermistor
+S_B4	1 x AI, 2 x AO
+S_B5	3 x RO
+S_B9	1 x RO, 5 x DI (42-240 VAC)
+S_BF	1 x AO, 1 x DO, 1 x RO
+S_BH	Temperature measurement
+S_E3	Profibus DPV1
+S_E5	Profibus DPV1 (D9)
+S_E6	CANopen
+S_E7	DeviceNET
+S_BJ	Safe Torque Off/ATEX
+FBIE	Ethernet IP and Profinet IO (software option onboard)
+QFLG	Flange mounting (MR4-MR7, for MR8 and MR9 with IP00)
+QDSS	Drive Supply Switch for MR4-MR7* (Requires +IP54)
+DBIN	Dynamic braking (for MR7-MR9)
Loose Options	Description
ENC-QFLG-MR0x	Flange Mounting Kit for MR4-MR7 (x=4,5,6 or 7)
ENC-IN12-MR0x	UL Type 12 Conversion Kit for MR4-MR6 (x = 4, 5, or 6)
VACON-PAN-HMDR-MK01-xM	Door Mounting Kit with optional Cable (NM = No Cable, 2M = 2m Cable, 3M = 3m Cable, 6M = 6m Cable, 15M = 15m Cable)
CAB-USB/RS485	PC Cable for interfacing with VACON Live

*+QDSS is not available for the 105A MR7 drive.

TECHNICAL DATA

Mains connection	Input voltage U _{in}	208...240 V; 380...500 V; -10%...+10%	
	Input frequency	47 - 65Hz	
	Connection to mains	Once per minute or less	
	Starting delay	4 s [MR4 to MR6]; 6 s [MR7 to MR9]	
Motor connection	Output voltage	0-U _{in}	
	Continuous output current	IL: Ambient temperature up to 40°C (104°F) overload 1.1 x I _L (1 min./10 min). IH: Ambient temperature up to 50°C (122°F) overload 1.5 x I _H (1 min./10 min).	
	Output frequency	0...320 Hz (standard)	
	Frequency resolution	0.01 Hz	
Control characteristics	Switching frequency	1.5...10 kHz; Automatic switching frequency reduction in case of overheating	
	Frequency reference	Resolution 0.01 Hz	
	Analog input	Resolution 0.1% (10-bit)	
	Field weakening point	8...320 Hz	
	Acceleration time	0.1...3000 sec	
	Deceleration time	0.1...3000 sec	
Ambient conditions	Ambient operating temperature	IL : -10°C (-14°F) (no frost)... +40°C (104°F) IH: -10C [-14°F](no frost)... +50°C (122°F)	
	Storage temperature	-40°C [-40°F]...+70°C [158°F]	
	Relative humidity	0 to 95% RH, non-condensing, non-corrosive	
	Air quality: EN/IEC 60068-2-60	• chemical vapors • mechanical particles	
	Altitude	EN/IEC 60721-3-3, unit in operation, class 3C2 (IP21), 3C3 (IP54) EN/IEC 60721-3-3, unit in operation, class 3S2 100% load capacity (no derating) up to 1.000 m (3280 ft) 1% derating for each 100 m (328 ft) above 1.000 m (3280 ft) Max. altitudes: 4000 m [13123 ft] (TN and IT systems) 240V relay voltage up to 3000m [9842 ft] from 3000 m ...4000m [9842 ft ... 13123 ft] 120V relay voltage can be used.	
	Vibration	EN/IEC 61800-5-1 EN/IEC 60068-2-6	
	Shock	EN/IEC 61800-5-1 EN/IEC 60068-2-27	
	Enclosure class	IP21/UL Type 1 standard in entire range IP54/UL Type 12 option IP00 for frames MR8, MR9	
EMC (at default settings)	Immunity	Fulfils EN/IEC 61800-3, first and second environment	
	Emissions	61800-3, Category C2 Vacon 100 will be delivered with class C2 EMC filtering, if not otherwise specified. Vacon 100 can be modified for IT networks NOTE: All models ending in "-R02" are delivered as EMC4.	
Emissions	Average sound pressure level in dB(A) (1 m from the drive)	MR4: 45...56 MR5: 57...65 MR6: 63...72 MR7: 43...73 MR8: 58...73 MR9: 54...75	Sound pressure depends on the cooling fans speed which is controlled in accordance with the drive temperature.
Safety and Approvals		EN/IEC 61800-5-1, EN/IEC 61800-3, EN/IEC 61000-3-12, UL 508 C, CE, UL, cUL, GOST-R, C-Tick; (see unit nameplate for more detailed approvals)	
Functional safety *	STO	EN/IEC 61800-5-2 Safe Torque Off (STO) SIL3, EN ISO 13849-1 PL"e" Category 3, EN 62061: SILCL3, IEC 61508: SIL3.	
	SS1	EN /IEC 61800-5-2 Safe Stop 1 (SS1) SIL2, EN ISO 13849-1 PL"d" Category 3, EN /IEC62061: SILCL2, IEC 61508: SIL2.	
	ATEX Thermistor input	94/9/EC, CE 0537 Ex 11 [2] GD	

* Optional

WE ARE DRIVES



VACON[®] 100 FLOW



TAKING CARE OF THE ESSENTIALS

The Water & Wastewater and Building Automation industries are two key ingredients in our everyday lives and yet so often go unnoticed. In fact, the only time most people become aware of them is when a problem arises somewhere along the line. VACON® 100 FLOW is designed to ensure pump and fan solutions control air- and waterflow quietly, efficiently and without interruptions.

EXPERTISE IN THE FIELD

VACON 100 FLOW builds on a long and illustrious track record in the industry. Vacon has produced a number of significant innovations ever since the company's founding in 1993. In 1995 we introduced a Multipump application. VACON 100 FLOW further develops Multimaster technology, first introduced in 2002, to provide functionalities that significantly extend flow systems' lifecycle and reduce operational costs. Compared to conventional control schemes, VACON® AC Drives are typically able to reduce energy costs by as much as 30% in pump and fan applications, usually offering a return on investment of less than a year.

GOING WITH THE FLOW

Pumps and fans control the flow of water and air through the pipes, vents and waterways that are often out of

sight, and yet remain central to our lives. Like in so many industrial processes, AC drives optimize these systems and make sure that processes use as little energy as possible. Pumping process water, cooling water and other fluids usually requires that pressure remains constant despite varying demand. VACON 100 FLOW comes equipped with a number of innovative functions that ensure you achieve this.

24/7 SERVICE AND SUPPORT

When it comes to flow control processes, it's critical for systems to run smoothly at all times. Since Vacon is the world's leading company focusing entirely on AC drive solutions, it's only right that our aftermarket product care is second to none. We offer services that ensure products remain effective for as long as possible, so that repairs and downtime are kept to the bare minimum.



INTELLIGENT PUMP & FAN CONTROL

VACON® 100 FLOW is an AC drive dedicated to improving flow control in Water & Wastewater and Building Automation applications. It combines the core functionality of VACON® 100 with dedicated functions that are specifically designed with flow control application processes in mind. VACON 100 FLOW is available in a number of frame sizes with either IP21/UL Type 1 or IP54/UL Type 12 approved enclosures. It has a power range of 0.55 kW/0.75 HP to 160 kW/250 HP and a voltage range of 230 V to 500 V.

VACON® 100
FLOW

DEDICATED FUNCTIONALITY

VACON 100 FLOW places an emphasis on user-friendliness and functionalities created for use in pump & fan applications. We have used our extensive experience in the field to handpick all the features that are best suited to application requirements and putting them in one dedicated product. For instance, standard PID control eliminates the need for an external controller by using a sensor to control pump speed. This is useful when reacting to fluctuations in demand.

APPLICATION MENUS FOR WATER AND HVAC

StartUp Wizard and the Quick Setup menu make it easy for users to select the relevant parameters and monitoring values. Unique application menus guide the user through a quick and easy installation and commissioning, with all the relevant parameters presented to them without the need to navigate a long list. StartUp Wizard and the Quick Setup menu can be activated either through the detachable keypad or by using VACON® Live, Vacon's online PC programming tool for AC drives.

CONNECT TO YOUR CONTROL SYSTEM

All VACON 100 series AC drives are equipped with built-in Ethernet. This feature means that no additional options or gateways are needed to communicate with process automation. It also provides access for commissioning and maintenance through VACON Live and makes local or remote monitoring possible.

BUILT TO LAST WITHOUT INTERRUPTION

Unplanned downtime is a problem for all applications, not least pump and fan systems, which is why it is important that components have as long a lifecycle as possible. VACON 100 FLOW uses electrolytic-free DC link technology which guarantees users the longest possible lifecycle and availability. By avoiding the need to replace electrolytic capacitors — that often wear out over time — interruptions and costs are kept to a minimum.

SMART INTEGRATION TO YOUR PLANT AUTOMATION

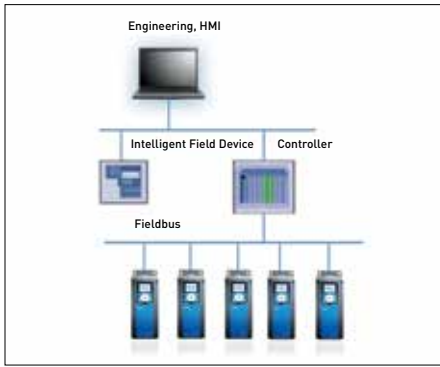

FIELDBUS OPTIONS

VACON® 100 is easily integrated with your plant's automation system using built-in Modbus RTU (RS485) or Modbus TCP (Ethernet). Integration over Profinet IO or Ethernet IP systems is made possible through software options. Click-in fieldbus options facilitate integration to traditional systems using Profibus DP, DeviceNet, CANOpen & LONWorks. Fieldbus technology ensures increased control and monitoring of the process equipment with reduced cabling.

Standard: Modbus RTU, BACNet MSTP, Metasys N2
Option Cards: Profibus DP, DeviceNet, LONWorks, CANOpen

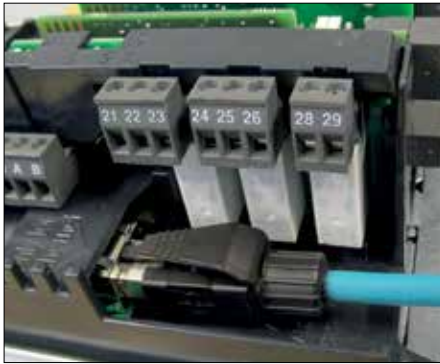

BUILT-IN ETHERNET

Ethernet based communication is common in all process industries today and VACON 100 is an obvious economical choice. No additional options or gateways are needed for the communication with process automation due to its unique built-in Ethernet. It not only provides access for commissioning and maintenance through VACON® Live but also makes local or remote wireless monitoring possible.

Standard: Modbus TCP, BACNet IP
Included in -R02: Profinet I/O, Ethernet IP

VACON® 100
FLOW

FUNCTIONAL SAFETY

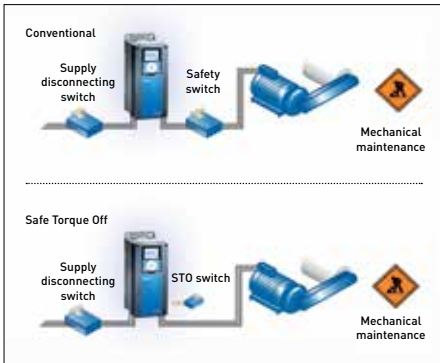

SAFE TORQUE OFF, SAFE STOP 1*

Safe Torque Off (STO) prevents the drive from generating torque on the motor shaft and prevents unintentional start-ups. The function also corresponds to an uncontrolled stop in accordance with stop category 0, EN60204-1. Safe Stop 1 (SS1) initiates motor deceleration and initiates the STO function after an application specific time delay. The function also corresponds to a controlled stop in accordance with stop category 1, EN 60204-1.

The advantage of the integrated STO and SS1 safety options compared to standard safety technology using electromechanical switchgear is the elimination of separate components and the effort required to wire and service them, while still maintaining the required level of safety at work.

* Requires OPT-BJ-V Option Card

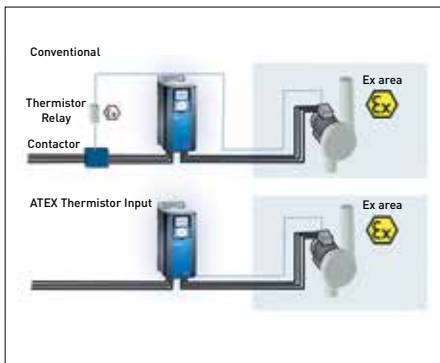

ATEX CERTIFIED THERMISTOR INPUT*

Vacon has developed an ATEX approved thermistor input, as an integrated option. Certified and compliant with the European ATEX directive, 94/9/EC, the integrated thermistor input is specially designed for the temperature supervision of motors that are placed in areas in which potentially explosive gas, vapor, mist or air mixtures are present and areas with combustible dust. Typical industries requiring such supervision include chemical, petrochemical, marine, metal, mechanical, mining, and oil drilling. If over-heating is detected, the drive immediately stops feeding energy to the motor. As no external components are needed, the cabling is kept to a minimum, improving reliability and saving on both space and costs.

* Requires OPT-BJ-V Option Card

USER FRIENDLY KEYPAD

Vacon has ensured that the user interface is simple and intuitive to use. You will enjoy the keypad's well-structured menu system that allows for fast commissioning and trouble-free operation.

- Graphical and text keypad with multiple language support
- 9 signals can be monitored at the same time on a single multimonitor page and is configurable to either 9,6 or 4 signals
- 3 color LED status indication on the control unit:
 - **blinking green** = ready; **green** = run; **red** = fault
- Trend display for two signals at the same time



QUICK SET UP

Easy commissioning tools ensure a hassle-free set up whatever the application. Easy diagnostic with help in plain text is provided for each parameter, signal and fault.

- Startup Wizard** — for fast setup of basic pump or fan applications
- PID Mini-Wizard** — for easy commissioning of internal PID Controller
- Multi-Pump Wizard** — for easy commissioning of Multi-Pump system
- Fire Mode Wizard** — for easy commissioning of Fire Mode function

VACON® 100 also features a real time clock with calendar based functions.



EASY INSTALLATION

Both IP21/UL Type 1 and IP54/UL Type 12 units have the same footprint making either an easy choice. Compact IP54/UL Type12 units can be installed side by side and require no additional space between them. Frame size MR8 and MR9 are available as IP00 for cabinet installation. Our flange mounting option makes through-hole mounting in the enclosure possible, with the heat sink remaining outside the enclosure. This significantly reduces heat losses in the enclosure and thus the enclosure size. Likewise, integrated lead-in grommets and 360 degree grounding improve both the IP54/UL Type 12 and EMC respectively, and lead to further cost savings.



VACON® 100
FLOW

DRIVE CUSTOMIZER

VACON 100 comes equipped with a built-in functionality that enables the drive to adapt to almost any function requiring I/O and control logic. The drive customizer function features a wide array of logical and numerical function blocks that can combine and extend standard drive functionalities, ensuring specific user requirements are met. The drive customizer does not require any special tools or training, while a fully graphical configuration can be performed using our own configuration tool, VACON® Live. Configurations can be copied using VACON Live as part of the normal parameter list.

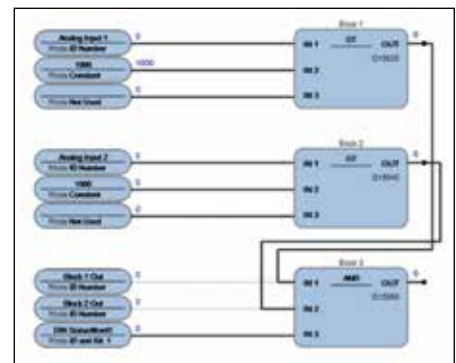



MULTIPUMP CONTROL SOLUTIONS

Vacon has long provided pump and fan solutions which ensure that users get the best functionality and cost-efficiency out of their process. We are able to offer three Multipump control solutions, each of which offers unsurpassed control of flow and pressure.

Demand for water or ventilation fluctuates throughout the course of a day. For instance, demand for running water in a major city usually peaks in the morning, as a great number of inhabitants are in the shower preparing for the working day. Conversely, in the middle of the night next to no water is being used.

By using several pumps as opposed to a single one, higher redundancy and efficiency is achieved since the load is lightened by being spread across several pumps. It also makes for greater redundancy – if one pump fails, the others can take on its load.

SINGLE DRIVE SYSTEM

Multipump control is a single-drive solution in which one AC drive controls the leading pump. If the demand exceeds the capabilities of the pump, additional fixed-speed pumps can be connected online directly or with a soft starter. You can choose between fixed setups and solutions in which the leading and auxiliary pumps alternate in roles to equalize wear and tear.

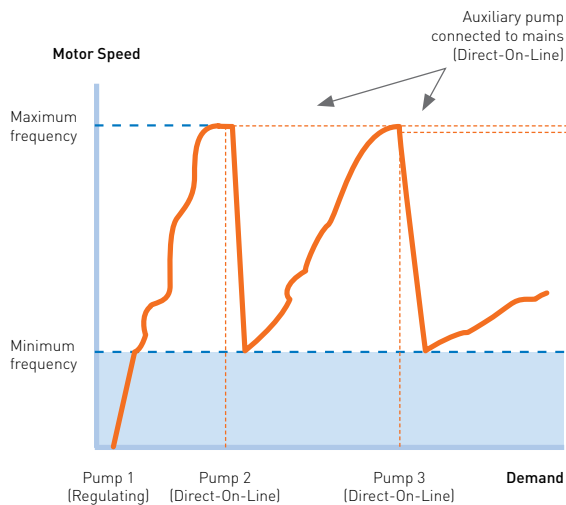

Single drive Multipump

SINGLE DRIVE SYSTEM IN BRIEF

- Maximum 8 pumps
- No need for an external controller
- Alternation of all pumps or only auxiliary pumps

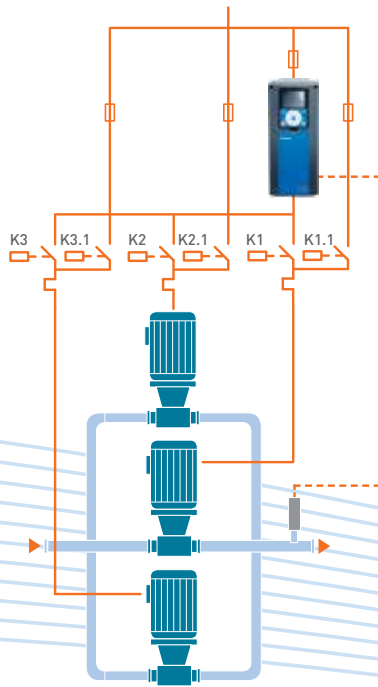

Single drive system

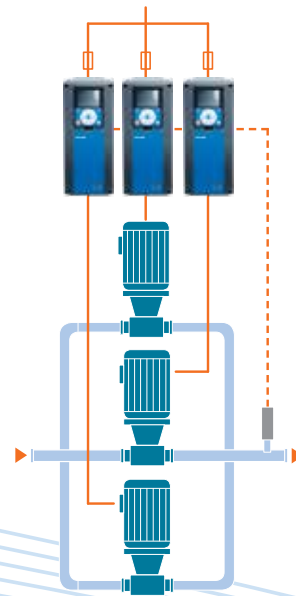

Multi drive system

MULTIDRIVE SYSTEMS

In **Multimaster** technology, each pump is controlled by its own AC drive. The integrated RS-485 interface allows the drives to communicate without the need for any external controller. As demand increases, the leading drive increases its speed until the capacity is exceeded, at which point the excess load is transferred to the next drive in the series. This method ensures pumps start and stop smoothly, and reduces the need for additional control wiring, motor protection relay and contactors.

Multifollower mode follows the same principle as Multimaster in that each pump is controlled by its own AC drive. Where this system differs is that, as demand increases and the lead drive's capacity is exceeded, additional drives running in parallel are brought into operation. This ensures that all pumps run at the same operating speed, reducing noise and general stress, thus improving reliability.

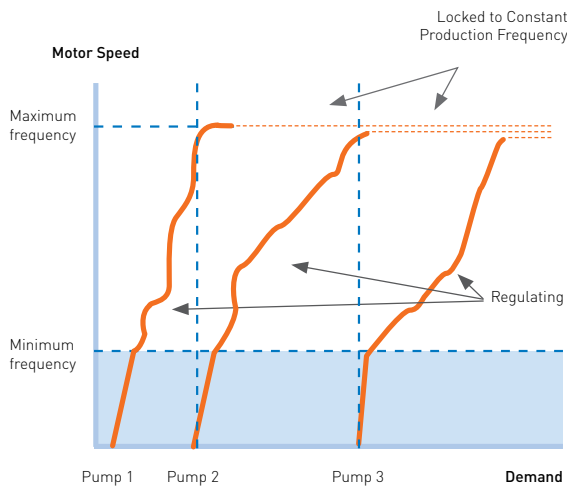

Multimaster

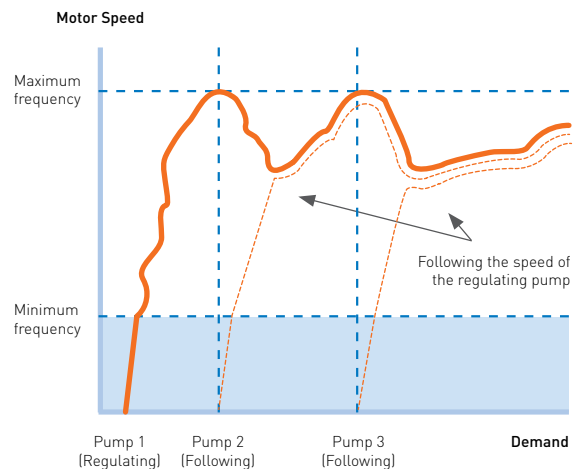

Multifollower

MULTIDRIVE SYSTEMS IN BRIEF

- Maximum 8 pumps
- No need for an external controller
- Communication between drives using integrated RS-485

MULTIPUMP FEATURES

FUNCTION	DESCRIPTION	BENEFITS
Multipump single drive	Multipump solution with one drive and auxiliary pumps running at fixed speeds	Simplest multipump solution
Multipump Multifollower	Intelligent multipump solution using parallel pumps with comprehensive speed control	Efficient pumping and minimal noise for systems with large flow variations.
Multipump Multimaster	Intelligent speed control of parallel pumps with speed control of all pumps	Efficient pumping in systems with large flow variations
Multipump interlocking of pumps	Able to disconnect pumps from multipump system using a digital signal	Avoid unnecessary downtime during pump system maintenance
Multipump diagnostics	Monitor usage period and number of starts for each pump	Enables preventive maintenance based on pump usage
Anti-blocking system	Ensures inactive pumps are run at regular intervals to avoid deterioration.	High level of redundancy ensures pumps remain in good condition
Multipump overpressure protection	Fast disconnect of pumps during periods of high line pressure	Reduces the risk of overpressure in case of sudden flow reduction
Pump alternation within multipump systems	Alternates multipump control sequence	Usage spread equally across all pumps
Real-time clock based multipump alternation	Alternates pumps at designated times	Spreads load across pumps to reduce wear and tear

PUMPING FEATURES

FUNCTION	DESCRIPTION	BENEFITS
PID controller	Built-in controller that controls drive speed to maintain constant pressure	No need for external controllers
Second PID controller	Built-in controller that can be used to control external equipment	Saves the need of using external controllers
2-Zone PID control	Control of two parallel process values	Better process control when two values are needed simultaneously
Frost protection for pump	Temperature-sensitive sleep mode for pump	Reduces risk of frost-induced damages to pump
Pressure loss compensation	Compensates pressure loss in piping when pressure sensor is close to pump	Stabilizes pressure in systems with long pipes
Start boost	Increased starting torque	Ensures that pump starts reliably
Sleep boosting	Increases system pressure before entering sleep mode	Maximizes pressure buffering time before wakeup e.g. in hydrofor applications
No demand detection	Ensures pump pressure is speed-responsive	Ensures that the pump does not run at unnecessarily high speeds, reducing energy consumption
Soft filling of pipe	Runs the pump at low speed until a pressure increase indicates the pipe is full	Reduces the risk of water hammers in the piping system
Dry pump supervision	Stops pump when there is not enough torque on the motor shaft	Protects the pump from damage from long dry runs
Priming pump	Control of additional priming pump with relay output	Main pump and piping automatically filled with water during startup
Jockey pump	Control of small jockey pump during low flow hours to maintain pressure	Main pump can be disconnected during periods of low demand
Auto-cleaning / anti-ragging	Detects when pump torque is increasing due to blocked pump and runs a user-defined cleaning sequence	Reduces risk of unplanned downtime in wastewater applications

MAINS VOLTAGE 208—240 V, 50/60 HZ, 3~

AC drive type	Output Power and Current Low Overload (110%)			Frame size	Dimensions		Weight	
	HP	kW	I _L (A)		mm	inches	kg	lb
VACON 0100-3L-0003-2-FLOW-R02	0.75	0.55	3.7	MR4	128x328x190	5x12.9x7.5	6.0	13.0
VACON 0100-3L-0004-2-FLOW-R02	1.0	0.75	4.8					
VACON 0100-3L-0007-2-FLOW-R02	1.5	1.1	6.6					
VACON 0100-3L-0008-2-FLOW-R02	2.0	1.5	8.0					
VACON 0100-3L-0011-2-FLOW-R02	3.0	2.2	11.0					
VACON 0100-3L-0012-2-FLOW-R02	-	3.0	12.5					
VACON 0100-3L-0018-2-FLOW-R02	5.0	4.0	18.0	MR5	144x419x214	5.7x16.5x8.4	10.0	22.0
VACON 0100-3L-0024-2-FLOW-R02	7.5*	5.5	24.0					
VACON 0100-3L-0031-2-FLOW-R02	10.0	7.5	31.0					
VACON 0100-3L-0048-2-FLOW-R02	15.0	11.0	48.0	MR6	195x557x229	7.7x21.9x9	20.0	44.0
VACON 0100-3L-0062-2-FLOW-R02	20.0	15.0	62.0					
VACON 0100-3L-0075-2-FLOW-R02	25.0	18.5	75.0	MR7	237x660x259	9.3x26x10.2	37.5	83.0
VACON 0100-3L-0088-2-FLOW-R02	30.0	22.0	88.0					
VACON 0100-3L-0105-2-FLOW-R02	40.0*	30.0	105.0					
VACON 0100-3L-0140-2-FLOW-R02	50.0*	37.0	140.0	MR8	290x966x343	11.4x38x13.5	66.0	145.5
VACON 0100-3L-0170-2-FLOW-R02	60.0	45.0	170.0					
VACON 0100-3L-0205-2-FLOW-R02	75.0*	55.0	205.0					
VACON 0100-3L-0261-2-FLOW-R02	100.0*	75.0	261.0	MR9	480x1150x365	18.9x45.3x14.4	108.0	238.0
VACON 0100-3L-0310-2-FLOW-R02	125**	90.0	310.0					
VACON 0100-3L-0140-2-FLOW-R02+IP00	50.0*	37.0	140.0	MR8 IP00	290x794x343	11.4x31.3x13.5	62.0	136.7
VACON 0100-3L-0170-2-FLOW-R02+IP00	60.0	45.0	170.0					
VACON 0100-3L-0205-2-FLOW-R02+IP00	75.0*	55.0	205.0					
VACON 0100-3L-0261-2-FLOW-R02+IP00	100*	75.0	261.0	MR9 IP00	480x970x365	18.9x38.2x14.4	97.0	213.8
VACON 0100-3L-0310-2-FLOW-R02+IP00	125**	90.0	310.0					

* HP Ratings only valid for 240V. Check motor FLA for 208V motors.
 ** NEMA Standard for 240V, 125HP is 312A. Check motor FLA before selecting this drive.

MAINS VOLTAGE 380—500 V, 50/60 HZ, 3~

AC drive type	Output Power and Current Low Overload (110%)			Frame size	Dimensions		Weight	
	HP	kW	I _L (A)		mm	inches	kg	lb
VACON 0100-3L-0003-5-FLOW-R02	1.5	1.1	3.4	MR4	128x328x190	5x12.9x7.5	6.0	13.0
VACON 0100-3L-0004-5-FLOW-R02	2.0	1.5	4.8					
VACON 0100-3L-0005-5-FLOW-R02	3.0	2.2	5.6					
VACON 0100-3L-0008-5-FLOW-R02	-	3.0	8.0					
VACON 0100-3L-0009-5-FLOW-R02	5.0	4.0	9.6					
VACON 0100-3L-0012-5-FLOW-R02	7.5	5.5	12.0					
VACON 0100-3L-0016-5-FLOW-R02	10.0	7.5	16.0	MR5	144x419x214	5.7x16.5x8.4	10.0	22.0
VACON 0100-3L-0023-5-FLOW-R02	15.0	11.0	23.0					
VACON 0100-3L-0031-5-FLOW-R02	20.0	15.0	31.0					
VACON 0100-3L-0038-5-FLOW-R02	25.0	18.5	38.0	MR6	195x557x229	7.7x21.9x9	20.0	44.0
VACON 0100-3L-0046-5-FLOW-R02	30.0	22.0	46.0					
VACON 0100-3L-0061-5-FLOW-R02	40.0	30.0	61.0					
VACON 0100-3L-0072-5-FLOW-R02	50.0	37.0	72.0	MR7	237x660x259	9.3x26x10.2	37.5	83.0
VACON 0100-3L-0087-5-FLOW-R02	60.0	45.0	87.0					
VACON 0100-3L-0105-5-FLOW-R02	75.0	55.0	105.0					
VACON 0100-3L-0140-5-FLOW-R02	100.0	75.0	140.0	MR8	290x966x343	11.4x38x13.5	66.0	145.5
VACON 0100-3L-0170-5-FLOW-R02	125.0	90.0	170.0					
VACON 0100-3L-0205-5-FLOW-R02	150.0	110.0	205.0					
VACON 0100-3L-0261-5-FLOW-R02	200.0	132.0	261.0	MR9	480x1150x365	18.9x45.3x14.4	108.0	238.0
VACON 0100-3L-0310-5-FLOW-R02	250.0	160.0	310.0					
VACON 0100-3L-0140-5-FLOW-R02+IP00	100.0	75.0	140.0	MR8*	290x794x343	11.4x31.3x13.5	62.0	136.7
VACON 0100-3L-0170-5-FLOW-R02+IP00	125.0	90.0	170.0					
VACON 0100-3L-0205-5-FLOW-R02+IP00	150.0	110.0	205.0					
VACON 0100-3L-0261-5-FLOW-R02+IP00	200.0	132.0	261.0	MR9*	480x970x365	18.9x38.2x14.4	97.0	213.8
VACON 0100-3L-0310-5-FLOW-R02+IP00	250.0	160.0	310.0					

VACON® 100
FLOW

TYPE CODE KEY

VACON 0100 - 3L - 0009 - 5 - FLOW + OPTION CODES

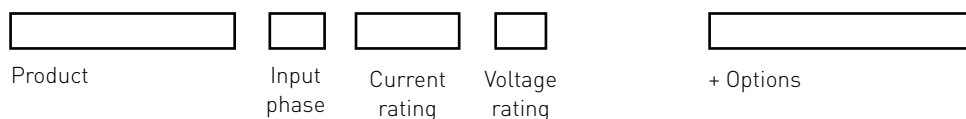

I/O CONFIGURATIONS & OPTIONS

Basic I/O board					
Terminal	Signal		Terminal	Signal	
1	+10 V _{ref}	Reference output	12	24 V _{out}	24 V aux. voltage
2	AI1+	Analog input, voltage or current	13	GND	I/O ground
3	AI1-	Analog input common (current)	14	DI4	Digital input 4
4	AI2+	Analog input, voltage or current	15	DI5	Digital input 5
5	AI2-	Analog input common (current)	16	DI6	Digital input 6
6	24 V _{out}	24 V aux. voltage	17	CM	Common A for DI1-DI6
7	GND	I/O ground	18	A01+	Analog signal (+output)
8	DI1	Digital input 1	19	A0-/GND	Analog output common
9	DI2	Digital input 2	30	+24 V _{in}	24 V auxiliary input voltage
10	DI3	Digital input 3	A	RS485	Differential receiver/transmitter
11	CM	Common A for DI1-DI6	B	RS485	Differential receiver/transmitter

Standard relay board			Optional relay board *		
Terminal	+SBF3		Terminal	+SBF4	
21	RO1/1 NC	Relay output 1	21	RO1/1 NC	Relay output 1
22	RO1/2 CM		22	RO1/2 CM	
23	RO1/3 NO		23	RO1/3 NO	
24	RO2/1 NC	Relay output 2	24	RO2/1 NC	Relay output 2
25	RO2/2 CM		25	RO2/2 CM	
26	RO2/3 NO		26	RO2/3 NO	
32	RO3/1 CM	Relay output 3	28	TI1+	Thermistor input
33	RO3/2 NO		29	TI1-	

* Standard relay board SBF3 (3XR0) can be replaced by SBF4 (2 x RO + Thermistor)

Ethernet Terminal	
Terminal	Signal
RJ45	Ethernet 10/100 Mbit/s

Factory Installed Options	Description
+SBF4	2 x Ro + Thermistor (Replaces 3 relay standard board)
+IP54	IP54 / UL Type 12
+IP00	IP00 (for MR8 and MR9)
+SRBT	Real-time clock battery
+HMTX	Text keypad
+HMPA	Panel adapter (Dummy Keypad)
+S_B1	6 x DI/DO
+S_B2	2 x RO + Thermistor
+S_B4	1 x AI, 2 x AO
+S_B5	3 x RO
+S_B9	1 x RO, 5 x DI (42-240 VAC)
+S_BF	1 x AO, 1 x DO, 1 x RO
+S_BH	Temperature measurement
+S_E3	Profibus DPV1
+S_E5	Profibus DPV1 (D9)
+S_E6	CANopen
+S_E7	DeviceNET
+S_BJ	Safe Torque Off/ATEX
+FBIE	Ethernet IP and Profinet IO (software option onboard)
+QFLG	Flange mounting (MR4-MR7, for MR8 and MR9 with IP00)
+QDSS	Drive Supply Switch for MR4-MR7* (Requires +IP54)
Loose Options	Description
ENC-QFLG-MR0x	Flange Mounting Kit for MR4-MR7 {x=4,5,6 or 7}
ENC-IN12-MR0x	UL Type 12 Conversion Kit for MR4-MR6 {x = 4, 5, or 6}
VACON-PAN-HMDR-MK01-xM	Door Mounting Kit with optional Cable (NM = No Cable; 2M = 2m Cable, 3M = 3m Cable, 6M = 6m Cable, 15M = 15m Cable)
CAB-USB/RS485	PC Cable for interfacing with VACON Live

*+QDSS is not available for the 105A MR7 drive.

Mains connection	Input voltage U_{in}	208...240 V; 380...500 V; -10%...+10%	
	Input frequency	47 - 65Hz	
	Connection to mains	Once per minute or less	
	Starting delay	4 s (MR4 to MR6); 6 s (MR7 to MR9)	
Motor connection	Output voltage	0- U_{in}	
	Continuous output current	II: Ambient temperature up to 40°C (104°F) overload 1.1 x II (1 min./10 min).	
	Output frequency	0...320 Hz (standard)	
	Frequency resolution	0.01 Hz	
Control characteristics	Switching frequency	1.5...10 kHz; Automatic switching frequency reduction in case of overheating	
	Frequency reference	Resolution 0.01 Hz	
	Analog input	Resolution 0.1% (10-bit)	
	Field weakening point	8...320 Hz	
	Acceleration time	0.1...3000 sec	
	Deceleration time	0.1...3000 sec	
Ambient conditions	Ambient operating temperature	IL : -10°C (-14°F) (no frost)... +50°C (122°F) Above +40°C (104°F) derating 1,5% per degree/°C	
	Storage temperature	-40°C (-40°F)...+70°C (158°F)	
	Relative humidity	0 to 95% RH, non-condensing, non-corrosive	
	Air quality: • Chemical vapors • Mechanical particles	EN/IEC 60721-3-3, unit in operation, class 3C2 (IP21), 3C3 (IP54) EN/IEC 60721-3-3, unit in operation, class 3S2	
	Altitude	100% load capacity (no derating) up to 1.000 m (3280 ft) 1% derating for each 100 m (328 ft) above 1.000 m (3280 ft) Max. altitudes: 4000 m [13123 ft] (TN and IT systems) 240V relay voltage up to 3000m [9842 ft] from 3000 m ...4000m [9842 ft ... 13123 ft] 120V relay voltage can be used.	
	Vibration	EN/IEC 61800-5-1 EN/IEC 60068-2-6	
	Shock	EN/IEC 61800-5-1 EN/IEC 60068-2-27	
	Enclosure class	IP21/UL Type 1 standard in entire range IP54/UL Type 12 option IP00/UL Open Type option for frames MR8, MR9	
EMC (at default settings)	Immunity	Fulfils EN/IEC 61800-3, first and second environment	
	Emissions	EN/IEC 61800-3, Category C2 Vacon 100 will be delivered with class C2 EMC filtering, if not otherwise specified. Vacon 100 can be modified for IT networks NOTE: All models ending in "-R02" are delivered as EMC4.	
Emissions	Average sound pressure level in dB(A) (1 m from the drive)	MR4: 45...56 MR5: 57...65 MR6: 63...72 MR7: 43...73 MR8: 58...73 MR9: 54...75	Sound pressure depends on the cooling fans speed which is controlled in accordance with the drive temperature.
Safety and Approvals		EN/IEC 61800-5-1, EN/IEC 61800-3, EN/IEC 61000-3-12, UL 508 C, CE, UL, cUL, GOST-R, C-Tick; [see unit nameplate for more detailed approvals]	
Functional safety *	STO	EN/IEC 61800-5-2 Safe Torque Off (STO) SIL3, EN ISO 13849-1 PL"e" Category 3, EN 62061: SILCL3, IEC 61508: SIL3.	
	ATEX Thermistor input	94/9/EC, CE 0537 Ex 11 (2) GD	

* Optional

VACON® 100
FLOW

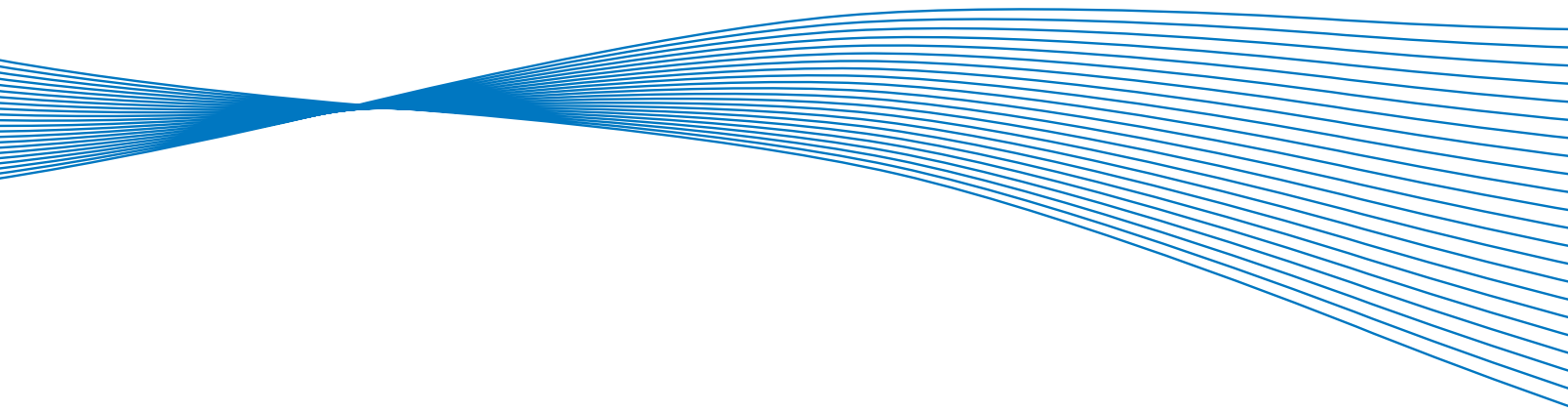

WE ARE DRIVES



VACON[®] 100 HVAC



IT'S EFFICIENCY THAT COUNTS

VACON® 100 HVAC is designed to meet and exceed even the stringent requirements of the building automation industry. Easy installation, efficient and trouble-free operation, and fast return on investment are guaranteed.

No HVAC task is too complex for VACON 100 HVAC. Installing and commissioning the VACON 100 HVAC can be done by just about anyone. VACON 100 HVAC is available in the power range of 0.55 to 160 kW (0.75 to 200 HP), and supply voltages of 230 to 480 V.

EFFICIENT INVESTMENT

With VACON® 100 HVAC, a short payback time is guaranteed as continuous energy savings are achieved throughout the product's lifetime. Further, a standard delivery of VACON 100 HVAC includes all the necessary hardware, I/O and communication features, usually with no need to buy any additional options. VACON 100 HVAC complies with all the relevant approvals and standards, including those for EMC and safety.

EASY INSTALLATION

VACON 100 HVAC, with its smallest IP54/UL Type 12 footprint and built-in accessories, makes installation extremely easy and fast. The high-resolution graphical keypad with intuitive wizards and online help add to the user-friendliness during installation and operation. Installation is space saving and easy as VACON 100 HVAC IP54/UL Type 12 units can be mounted side by side.



WHAT'S IN IT FOR YOU

SMOOTH OPERATION

Interference-free operation is ensured with built-in RFI filters and harmonics filters. VACON 100 HVAC operates silently in a building area with the use of high switching frequency and the optimum use of a cooling fan. With the help of a real-time clock and calendar-based functions, the HVAC process can be optimized to achieve considerable energy savings.

LONG LIFETIME

All the components of VACON 100 HVAC have a typical lifetime of 10 years or more, and they are environmentally friendly for easy recycling. There is no need to change any parts during periodic maintenance. Should you require help with your drive, Vacon guarantees that support and service are always available, both locally and globally.

VACON 100 HVAC

Features	Description	Benefits
User Friendly Programming	Plain English text, simple to navigate menus and embedded parameter descriptions make the VACON 100 HVAC extremely simple to program	<ul style="list-style-type: none"> • Effortless startup • Manual in the Keypad
Thin Film Capacitors	VACON 100 HVAC features a new technology capacitor that increases the shelf life to at least 10 years without any requirement for reforming the capacitor after a year	<ul style="list-style-type: none"> • 10 year shelf life • Reduced maintenance costs
Five Built-in Communications Protocols	VACON 100 HVAC features built-in 2-wire RS485 connection as well as a built-in RJ-45 port of TCP/IP based communications protocols such as BACnet/IP and Modbus/TCP	<ul style="list-style-type: none"> • Reduced system cost • Simple control system integration

VACON® 100
HVAC

FEATURES AND BENEFITS

BUILT IN

VACON® 100 HVAC is ready to communicate with an external controller via Ethernet and RS 485 protocols used in HVAC. BACnet IP and Modbus TCP via Ethernet and Modbus RTU, Metasys N2 and BACnet MSTP via RS485 are available as standard. **Saves on investment costs. Simple to order.**

VACON 100 HVAC has integrated harmonics filters in the DC link. Complies with the harmonics standard IEC 61000-3-12. **Saves on costs. No need for additional harmonics filter.**

All circuit boards are varnished. **High immunity against demanding environments.**

The IP21/UL Type 1 and IP54/UL Type 12 units have the same footprint, and the IP54/UL Type12 units can be mounted side by side. **Easy integration of IP21/UL Type 1 units to cabinets, smallest IP54/UL Type 12 saves space and investment costs.**

Thanks to the flange mounting option, VACON 100 HVAC can be mounted in the plenum, which allows easy integration with other HVAC equipment. **Saves on investment costs. Easy integration.**

INTEGRATED DRIVE SUPPLY SWITCH

Using the integrated drive supply switch option, the drive's main supply can be disconnected and locked during maintenance work. This option is UL, CE and CUL certified. To order, add +IP54+QDSS to the end of the type code. The Drive Supply Switch is only available in MR4-MR7, except for 105A models. **Saves on investment costs and space. Provides safety during maintenance.**

DEDICATED TO HVAC

2 x PID controller for accurate HVAC process control **Reduces the need for an external controller. Improves the performance of the HVAC system. Reduces investment costs as one PID controller is available for external use.**

Fire mode is enabled in case of a fire hazard in a building. VACON 100 HVAC overrides faults and continues to operate in spite of harsh conditions. **Safety in case of fire hazard, smooth evacuation in case of fire.**

The motor switch ride-through feature ensures tripless operation when the motor is disconnected and reconnected to the drive while running. **Fast and tripless maintenance of the motor or HVAC equipment.**

Using the multipump feature, a single VACON 100 HVAC drive can control the HVAC process with 4 pumps. **Reduces investment costs. Increases the lifetime of pumps.**





EASY TO USE KEYPAD

9 values can be monitored at the same time on a single page with the graphical keypad. **Monitors process and drive at the same time. Easy to use.**

Help in plain text is provided for parameters, faults and alarms. **Saves time during installation and maintenance. Often no need for manuals.**

Start-up wizard and mini-wizard guide the user with simple question and answer sessions through the installation of the drive and commissioning of advanced features such as PID and multipump. **Saves time, no need for special skills. Easy to use.**

SAVE ENERGY

All VACON® 100 HVAC drives have an efficiency level of more than 97,5%. **Energy saving.**

The use of a cooling fan in the VACON 100 HVAC is optimized and controlled according to the need. The cooling fan is also easy to replace. **Energy saving, longer lifetime and silent operation.**

When the sleep mode is used, the drive automatically stops when there is no demand from the process. It also wakes up on demand. **Energy saving.**

A real-time clock allows the HVAC process to run with 5 calendar-based schedules and 3 timer inputs. **Energy saving.**

SUPPORT FROM SOFTWARE TOOLS

The VACON® Live software tool communicates directly via Ethernet, and helps in installation, commissioning and maintenance. A USB-to-RS422 interface is also available. This software is free of charge. **Saves on operating and maintenance costs. Easy to configure and use.**

The drive as well as process-related values can be graphically monitored on a real-time axis. Parameters can be edited, saved for backup, and compared with defaults or a back-up file. **Easy commissioning and maintenance.**

A service info file can be sent quickly to maintenance staff or a service provider. It contains back-up of all parameters, faults and alarms, including a history buffer, as well as drive hardware and software details. **Reduces downtime. Saves on operating and maintenance costs.**



VACON® 100
HVAC

RATINGS AND DIMENSIONS

MAINS VOLTAGE 208—240 V, 50/60 HZ, 3~

AC drive type	Output Power and Current Low Overload (110%)			Frame size	Dimensions		Weight	
	HP	kW	I _L (A)		mm	inches	kg	lb
VACON 0100-3L-0003-2-HVAC-R02	0.75	0.55	3.7	MR4	128x328x190	5x12.9x7.5	6.0	13.0
VACON 0100-3L-0004-2-HVAC-R02	1.0	0.75	4.8					
VACON 0100-3L-0007-2-HVAC-R02	1.5	1.1	6.6					
VACON 0100-3L-0008-2-HVAC-R02	2.0	1.5	8.0					
VACON 0100-3L-0011-2-HVAC-R02	3.0	2.2	11.0					
VACON 0100-3L-0012-2-HVAC-R02	-	3.0	12.5					
VACON 0100-3L-0018-2-HVAC-R02	5.0	4.0	18.0	MR5	144x419x214	5.7x16.5x8.4	10.0	22.0
VACON 0100-3L-0024-2-HVAC-R02	7.5*	5.5	24.0					
VACON 0100-3L-0031-2-HVAC-R02	10.0	7.5	31.0					
VACON 0100-3L-0048-2-HVAC-R02	15.0	11.0	48.0	MR6	195x557x229	7.7x21.9x9	20.0	44.0
VACON 0100-3L-0062-2-HVAC-R02	20.0	15.0	62.0					
VACON 0100-3L-0075-2-HVAC-R02	25.0	18.5	75.0	MR7	237x660x259	9.3x26x10.2	37.5	83.0
VACON 0100-3L-0088-2-HVAC-R02	30.0	22.0	88.0					
VACON 0100-3L-0105-2-HVAC-R02	40.0*	30.0	105.0					
VACON 0100-3L-0140-2-HVAC-R02	50.0*	37.0	140.0	MR8	290x966x343	11.4x38x13.5	66.0	145.5
VACON 0100-3L-0170-2-HVAC-R02	60.0	45.0	170.0					
VACON 0100-3L-0205-2-HVAC-R02	75.0*	55.0	205.0					
VACON 0100-3L-0261-2-HVAC-R02	100.0*	75.0	261.0	MR9	480x1150x365	18.9x45.3x14.4	108.0	238.0
VACON 0100-3L-0310-2-HVAC-R02	125**	90.0	310.0					
VACON 0100-3L-0140-2-HVAC-R02+IP00	50.0*	37.0	140.0	MR8 IP00	290x794x343	11.4x31.3x13.5	62.0	136.7
VACON 0100-3L-0170-2-HVAC-R02+IP00	60.0	45.0	170.0					
VACON 0100-3L-0205-2-HVAC-R02+IP00	75.0*	55.0	205.0					
VACON 0100-3L-0261-2-HVAC-R02+IP00	100*	75.0	261.0	MR9 IP00	480x970x365	18.9x38.2x14.4	97.0	213.8
VACON 0100-3L-0310-2-HVAC-R02+IP00	125**	90.0	310.0					

* HP Ratings only valid for 240V. Check motor FLA for 208V motors.

** NEMA Standard for 240V, 125HP is 312A. Check motor FLA before selecting this drive.

MAINS VOLTAGE 380—480 V, 50/60 HZ, 3~

AC drive type	Output Power and Current Low Overload (110%)			Frame size	Dimensions		Weight	
	HP	kW	I _L (A)		mm	inches	kg	lb
VACON 0100-3L-0003-4-HVAC-R02	1.5	1.1	3.4	MR4	128x328x190	5x12.9x7.5	6.0	13.0
VACON 0100-3L-0004-4-HVAC-R02	2.0	1.5	4.8					
VACON 0100-3L-0005-4-HVAC-R02	3.0	2.2	5.6					
VACON 0100-3L-0008-4-HVAC-R02	4.0	3.0	8.0					
VACON 0100-3L-0009-4-HVAC-R02	5.0	4.0	9.6					
VACON 0100-3L-0012-4-HVAC-R02	7.5	5.5	12.0					
VACON 0100-3L-0016-4-HVAC-R02	10.0	7.5	16.0	MR5	144x419x214	5.7x16.5x8.4	10.0	22.0
VACON 0100-3L-0023-4-HVAC-R02	15.0	11.0	23.0					
VACON 0100-3L-0031-4-HVAC-R02	20.0	15.0	31.0					
VACON 0100-3L-0038-4-HVAC-R02	25.0	18.5	38.0	MR6	195x557x229	7.7x21.9x9	20.0	44.0
VACON 0100-3L-0046-4-HVAC-R02	30.0	22.0	46.0					
VACON 0100-3L-0061-4-HVAC-R02	40.0	30.0	61.0					
VACON 0100-3L-0072-4-HVAC-R02	50.0	37.0	72.0	MR7	237x660x259	9.3x26x10.2	37.5	83.0
VACON 0100-3L-0087-4-HVAC-R02	60.0	45.0	87.0					
VACON 0100-3L-0105-4-HVAC-R02	75.0	55.0	105.0					
VACON 0100-3L-0140-4-HVAC-R02	100.0	75.0	140.0	MR8	290x966x343	11.4x38x13.5	66.0	145.5
VACON 0100-3L-0170-4-HVAC-R02	125.0	90.0	170.0					
VACON 0100-3L-0205-4-HVAC-R02	150.0	110.0	205.0					
VACON 0100-3L-0261-4-HVAC-R02	200.0	132.0	261.0	MR9	480x1150x365	18.9x45.3x14.4	108.0	238.0
VACON 0100-3L-0310-4-HVAC-R02	250.0	160.0	310.0					
VACON 0100-3L-0140-4-HVAC-R02+IP00	100.0	75.0	140.0	MR8*	290x794x343	11.4x31.3x13.5	62.0	136.7
VACON 0100-3L-0170-4-HVAC-R02+IP00	125.0	90.0	170.0					
VACON 0100-3L-0205-4-HVAC-R02+IP00	150.0	110.0	205.0					
VACON 0100-3L-0261-4-HVAC-R02+IP00	200.0	132.0	261.0	MR9*	480x970x365	18.9x38.2x14.4	97.0	213.8
VACON 0100-3L-0310-4-HVAC-R02+IP00	250.0	160.0	310.0					

VACON® 100
HVAC

TYPE CODE KEY

VACON 0100 - 3L - 0009 - 4 - HVAC + OPTION CODES

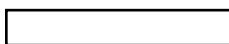

Product



Input
phase

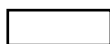

Current
rating



Voltage
rating

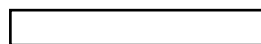

+ Options

Basic I/O board		
Terminal		Signal
1	+10 V _{ref}	Reference output
2	AI1+	Analog input, voltage or current
3	AI1-	Analog input common (current)
4	AI2+	Analog input, voltage or current
5	AI2-	Analog input common (current)
6	24 V _{out}	24 V aux. voltage
7	GND	I/O ground
8	DI1	Digital input 1
9	DI2	Digital input 2
10	DI3	Digital input 3
11	CM	Common A for DI1-DI6
12	24 V _{out}	24 V aux. voltage
13	GND	I/O ground
14	DI4	Digital input 4
15	DI5	Digital input 5
16	DI6	Digital input 6
17	CM	Common A for DI1-DI6
18	AO1+	Analog signal (+output)
19	AO-/GND	Analog output common
30	+24 V _{in}	24 V auxiliary input voltage
A	RS485	Differential receiver/transmitter
B	RS485	Differential receiver/transmitter

Standard relay board		Optional relay board	
Terminal	+SBF1	Terminal	+SBF2
21	R01/1 NC	21	R01/1 NC
22	R01/2 CM	22	R01/2 CM
23	R01/3 NO	23	R01/3 NO
24	R02/1 NC	24	R02/1 NC
25	R02/2 CM	25	R02/2 CM
26	R02/3 NO	26	R02/3 NO
32	R03/1 CM	28	TI1+
33	R03/2 NO	29	TI1-

Option boards (all boards are varnished)	
OPT-F1-V	3 x Relay output
OPT-F2-V	2 x Relay output + Thermistor
OPT-B1-V	6 x DI/DO, each I/O can be individually programmable as input or output
OPT-B2-V	2 x Relay output + Thermistor
OPT-B4-V	1 x AI, 2 x AO (isolated)
OPT-B5-V	3 x Relay output
OPT-B9-V	1 x RO, 5 x DI (42-240 VAC)
OPT-C4-V	LonWorks
OPT-BF-V	1 x AO, 1 x DO, 1 x RO

Standard relay board (3 x RO) can be replaced by SBF2 (2 x RO + Thermistor).

Factory options	Description
+SBF2	2 x Ro + Thermistor (Replaces 3 relay standard board)
+IP54	IP54 / UL Type 12
+IP00	IP00 / UL Open Type (for MR8 and MR9)
+SRBT	Real-time clock battery
+HMTX	Text keypad
+HMPA	Panel adapter
+S_B1	6 x DI/DO option board
+S_B2	2 x RO + Thermistor option board
+S_B4	1 x AI, 2 x AO option board
+S_B5	3 x RO option board
+S_B9	1 x RO, 5 x DI (42-240 VAC) option board
+S_BF	1 x AO, 1 x DO, 1 x RO option board
+S_BH	Temperature measurement option board (PT100, PT1000, NI1000, KTY84-130, KTY84-150, KTY84-131)
+QFLG	Flange mounting (MR4-MR7, for MR8 and MR9 with IP00)
+QDSS	Integrated Drive Supply Switch for MR4-MR7* (requires +IP54)
+QGLC	Conduit plate with inch holes
+EMC4	Change to EMC-level c4 for IT networks
Loose Options	Description
ENC-QFLG-MR0x	Flange Mounting Kit for MR4-MR7 (x=4,5,6 or 7)
ENC-IN12-MR0x	UL Type 12 Conversion Kit for MR4-MR6 (x = 4, 5, or 6)
VACON-PAN-HMDR-MK01-xM	Door Mounting Kit with optional Cable (NM = No Cable; 2M = 2m Cable, 3M = 3m Cable, 6M = 6m Cable, 15M = 15m Cable)
CAB-USB/RS485	PC Cable for interfacing with VACON Live
+FL05	English, German, Estonian, Hungarian, Romanian, Turkish

* Drive Supply Switch not available in 105A rated MR7.

TECHNICAL DATA

Mains connection	Input voltage U _{in}	208...240 V; 380...480 V; -10%...+10%
	Input frequency	50...60 Hz, -5%...+10%
	Connection to mains	Once per minute or less
	Starting delay	4 s (MR4 to MR6); 6 s (MR7 to MR9)
Motor connection	Output voltage	0-U _{in}
	Continuous output current	I _L : Ambient temperature up to 40°C (104°F) overload 1.1 x I _L (1 min./10 min.)
	Output frequency	0...320 Hz (standard)
	Frequency resolution	0.01 Hz
Control characteristics	Switching frequency	1.5...10 kHz; Automatic switching frequency derating in case of overheating
	Frequency reference	Resolution 0.01 Hz
	Analog input	Resolution 0.1% (10-bit)
	Field weakening point	8...320 Hz
	Acceleration time	0.1...3000 sec
	Deceleration time	0.1...3000 sec
Ambient conditions	Ambient operating temperature	IL : -10°C (-14°F) [no frost]...+50°C (131°F)
	Storage temperature	-40°C (-40°F)...+70°C (158°F)
	Relative humidity	0 to 95% RH, non-condensing, non-corrosive
	Air quality: IEC 60068-2-60 • chemical vapors • mechanical particles	IEC 60721-3-3, unit in operation, class 3C2 (IP21), 3C3 (IP54) IEC 60721-3-3, unit in operation, class 3S2
	Altitude	100% load capacity (no derating) up to 1.000 m (3280 ft) 1% derating for each 100 m (328 ft) above 1.000 m (3280 ft) Max. altitudes: 4000 m (13123 ft) (TN and IT systems) 240V relay voltage up to 3000m [9842 ft] from 3000 m ...4000m [9842 ft ... 13123 ft] 120V relay voltage can be used.
	Vibration	IEC 61800-5-1 IEC 60068-2-6
	Shock	IEC 61800-5-1 IEC 60068-2-27
	Enclosure class	IP21/Type 1 standard in entire range IP54/Type 12 option
EMC (at default settings)	Immunity	Fulfils IEC 61800-3, first and second environment EN/IEC 61800-3, Category C2
	Emissions	VACON 100 HVAC will be delivered with class C2 EMC filtering, if not otherwise specified. VACON 100 HVAC can be modified for IT networks NOTE: All models ending in "-R02" are delivered as EMC4.
Emissions	Average sound pressure level in dB(A) (1 m from the drive)	MR4: 56, MR5: 61, MR6: 68, MR7: 68, MR8: 77, MR9: 78
Safety and Approvals		EN 61800-5-1, EN 61800-3, EN 61000-3-12, UL 508 C, CE, UL, cUL, GOST-R; [see unit nameplate for more detailed approvals]

WE ARE DRIVES



VACON[®] 100 X



VACON® 100 X — A DECENTRALIZED DRIVE LIKE NO OTHER

The VACON 100 X sets a new benchmark for decentralized drive solutions. It has a power range up to 37 kW (40 HP), comes with IP66/UL Type 4X protection and has highly advanced control capability which guarantees processes run exactly how you want them to. On top of all this, it has built-in harmonic filtering chokes, making it suitable for public networks.

TOP CLASS PROTECTION

IP66/UL Type 4X approval means that VACON 100 X comes with all the protection it needs in order to stand up to the challenges that demanding applications can throw at it. The robust, die-cast metal frame is strong enough to withstand 3g vibrations, and its cooling capabilities are second to none. The enclosure is powder coated for protection against corrosion and is designed to be fully operational in outdoor environments. A GORE® Snap-in Vent (Membrane IP69K) is designed to prevent external factors such as dust or moisture reaching inside the drive, while offering “in/out” pressure equalization, preventing the sealing from being worn down. In short, there really is no other option with such capabilities for high performance in challenging environments.

INTO THE HEAT OF THE ACTION

The enclosure’s heatsink is easy to clean and the large, open cooling ribs allow the drive to perform in temperatures up to 60°C (with derating). The cooling system is such that it is not dependent on motor airflow like most motor mounted drives, and the fan is speed-controlled and pluggable, and therefore easy to replace.

PROGRAMMING DESIGNED FOR OEMS

Built-in PLC functionality, using IEC61131-1 programming methods, allows software logic and parameter list definitions to be modified with the optional VACON® Programming Tool. This means that users can customize the drive around their requirements, making it an attractive option for OEM customers.

TECHNICAL HIGHLIGHTS

- IP66/Type 4X enclosure
- 3g resistance to vibrations
- Supports both induction and permanent magnet motors
- Option of ability to operate in temperatures ranging from -40°C to 60°C
- Integrated with RS485 Modbus and Ethernet communication
- Safe Torque Off (STO) mode according to SIL3
- Built-in EMC filter for EN61800-3 category C2
- DC thin choke and film capacitor
- Integrated brake chopper

BENEFITS

- Able to withstand rough conditions such as heat, dirt and vibrations
- Easy to keep clean
- Approval for public networks makes it flexible for installation
- Vacon Programming enables top class integration for countless OEM applications
- High efficiency and simulated air flow ensure long lifetime
- Mountable in any position; fits into any available space



RATINGS & DIMENSIONS

Supply voltage	AC drive type	Output Power and Current High Overload (150%)			Frame size	Dimensions W x H x D		Weight	
		HP	kW	I _N [A]		mm	inches	kg	lb
208-240 VAC, 3-phase	VACON0100-3L-0006-2-X-R02	1.5	1.1	6.6	MM4	191 x 314 x 187	7.52 x 12.36 x 7.36	8.8	19.4
	VACON0100-3L-0008-2-X-R02	2.0	1.5	8.0					
	VACON0100-3L-0011-2-X-R02	3.0	2.2	11.0					
	VACON0100-3L-0012-2-X-R02	4.0	3.0	12.5					
	VACON0100-3L-0018-2-X-R02	5.0	4.0	18.0	MM5	233 x 366 x 205	9.17 x 14.41 x 8.07	14.9	32.9
	VACON0100-3L-0024-2-X-R02	7.5	5.5	24.2					
	VACON0100-3L-0031-2-X-R02	10.0	7.5	31.0	MM6	350 x 500 x 235	13.78 x 19.69 x 9.25	31.5	69.5
	VACON0100-3L-0048-2-X-R02	15.0	11.0	48.0					
VACON0100-3L-0062-2-X-R02	20.0	15.0	62.0						
380-480 VAC, 3-phase	VACON0100-3L-0003-4-X-R02	1.5	1.1	3.4	MM4	191 x 314 x 187	7.52 x 12.36 x 7.36	8.8	19.4
	VACON0100-3L-0004-4-X-R02	2.0	1.5	4.8					
	VACON0100-3L-0005-4-X-R02	3.0	2.2	5.6					
	VACON0100-3L-0008-4-X-R02	5.0	3.0	8.0					
	VACON0100-3L-0009-4-X-R02	5.0	4.0	9.6	MM5	233 x 366 x 205	9.17 x 14.41 x 8.07	14.9	32.9
	VACON0100-3L-0012-4-X-R02	7.5	5.5	12.0					
	VACON0100-3L-0016-4-X-R02	10.0	7.5	16.0					
	VACON0100-3L-0023-4-X-R02	15.0	11.0	23.0	MM6	350 x 500 x 235	13.78 x 19.69 x 9.25	31.5	69.5
	VACON0100-3L-0031-4-X-R02	20.0	15.0	31.0					
	VACON0100-3L-0038-4-X-R02	25.0	18.5	38.0	MM6	350 x 500 x 235	13.78 x 19.69 x 9.25	31.5	69.5
	VACON0100-3L-0046-4-X-R02	30.0	22.0	46.0					
	VACON0100-3L-0061-4-X-R02	40.0	30.0	61.0					
	VACON0100-3L-0072-4-X-R02	50.0*	37.0*	72.0*					

* Low Overload (110%)

TYPE CODE KEY

VACON 0100 - 3L - 0009 - 5 - X + OPTION CODES

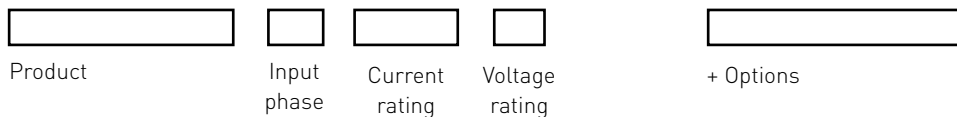

TYPICAL APPLICATIONS

- Machinery
- Conveyors
- Pumps
- Fans
- Decentralized solutions in a high variety of applications
- Outdoor applications
- Applications exposed to vibrations

WHAT'S INSIDE VACON® 100 X

TÜV/SÜD CERTIFIED SOLUTION



GORE® VENT

Just like VACON 20® X, VACON 100 X comes with a GORE® vent which allows the enclosure to breathe, however harsh the external conditions, and prevents it from getting worn down. This acts as a barrier against condensation, dust and dirt and ensures pressure inside the drive is equalized with the surrounding environment.

LARGE COOLING RIBS

The front of the drive's enclosure offers cooling protection with ribs that don't collect dust. They allow full access to the heatsink and can be cleaned with pressurized water. This makes them easy to maintain and ensures reliable operation.

TERMINAL BOX

A single box that contains all the drive's wiring and the control unit, freeing up space elsewhere.

POWER HEAD

All the power components are contained in one compact and robust unit. Removable connectors are always used to make connections, meaning the power head can be easily removed where needed.

MOTOR MOUNTABLE

The drive can be mounted onto any flat surface. Motor mounting is done using additional adaptable parts.

EXPANSION SLOTS FOR ADDITIONAL OPTION BOARDS

Two expansion slots open up the possibility of connecting to other fieldbuses and I/O boards.

MOUNTABLE IN FOUR ORIENTATIONS

Both the drive and the keypad can be mountable in four positions. This means that however you set up the VACON 100 X, the keypad will remain easily operable. Since there are no electrical cable connections to worry about, it can even be rotated in the field.

MAINS SWITCH INTEGRATED AS OPTION

Using the integrated drive supply switch option, the drive's main supply can be disconnected and locked during maintenance work. This helps save on investment costs and space and provides safety during the job.

I/O CONNECTIONS

Standard I/O		
Terminal		Signal
A	RS485	Differential receiver / transmitter
B	RS485	Differential receiver / transmitter
1	+10V _{ref}	Reference output
2	AI1+	Analog input 1, voltage or current
3	AI1- / GND	Analog input 1 common
4	AI2+	Analog input 2, voltage or current
5	AI2- / GND	Analog input 2 common
6	24V _{out}	24 V aux. voltage
7	GND	I/O ground
8	DI1	Digital input 1
9	DI2	Digital input 2
10	DI3	Digital input 3
11	DICOM A	Common for DI1 - DI3
12	24V _{out}	24 V aux. voltage
13	GND	I/O ground
14	DI4	Digital input 4
15	DI5	Digital input 5
16	DI6	Digital input 6
17	DICOM B	Common for DI4 - DI6
18	AO1+	Analog output (+output), voltage current
19	AO1- / GND	Analog output signal common (-output)
30	24 V	24 V aux. input voltage

OPTIONS

VACON-PAN-HMGR-MC05	Magnetic Handheld keypad
POW-QDSS-MM4	Integrated Mains switch MM4
POW-QDSS-MM5	Integrated Mains switch MM5
POW-QDSS-MM6	Integrated Mains switch MM6
ENC-QAFH-MM04	Artic mode heater

Relays		STO connections		
Terminal		Terminal		
21	RO1/1 NC	Relay output 1	S1	Isolated digital output 1
22	RO1/2 CM		G1	
23	RO1/3 NO			
24	RO2/1 NC	Relay output 2	S2	Isolated digital output 2
25	RO2/2 CM		G2	
26	RO2/3 NO			F+
			F-	
28	Thermistor input			
29				

OPTION BOARDS

Option boards	
OPT-B1-V	6 x DI/DO, each digital input can be individually programmed to also act as digital output
OPT-B2-V	2 x Relay output + Thermistor
OPT-B4-V	1 x AI, 2 x AO (isolated)
OPT-B5-V	3 x Relay output
OPT-B9-V	1 x RO, 5 x DI (42-240 VAC)
OPT-BF-V	1 x AO, 1 x DO, 1 x RO
OPT-E3-V	Profibus DPV1, (screw connector)
OPT-E5-V	Profibus DPV1, (ID9 connector)
OPT-E6-V	CANopen
OPT-E7-V	DeviceNet

ENC-QAFH-MM05	Artic mode heater
ENC-QAFH-MM06	Artic mode heater
QFLG-ALL-MM4	Motor mounting flange adapter
QFLG-ALL-MM5	Motor mounting flange adapter
QFLG-ALL-MM6	Motor mounting flange adapter

GENERAL

Communication	RS485	Standard: Modbus RTU, BACnet, N2
	Ethernet	Standard: Modbus TCP
	HMI	RS422 based for PC tools or Keypad interface
Software features	Control characteristics	Induction and PMSM motor control Switching frequency up to 16 kHz (factory default 6 kHz) Frequency control U/f and Open loop sensorless vector control Motor tuning identification and flying start mode
Motor connection	Output voltage	0...U _{in}
	Output current	Continuous rated current I _n at rated ambient temperature Overload 1.5 x I _n max 1 min / 10 min
	Starting current / torque	Current 2 x I _n for 2 secs every 20 sec period
	Output frequency	0...320 Hz - resolution 0.01 Hz
Ambient conditions	Ambient operating temperature	-10 °C...+40 °C without derating [max. temperature 60°C with derating]; Arctic mode as option with temperature down to -40°C
	Vibration Altitude	3g resistance to vibrations (according to 3M7/IEC 60068-2) 100% load capacity (no derating) up to 1000 m; 1% derating every 100 m up to 3000 m
	Enclosure class	IP66 / Type 4X
EMC	Immunity Emissions	Complies with EN 61800-3, level C2 (C1 as option) NOTE: All models with "-R02" are delivered as EMC4.
Functional safety	Safe Torque Off (STO)	SIL 3 according to IEC61800-5-2 PL e / Cat 4 according to ISO13849-1

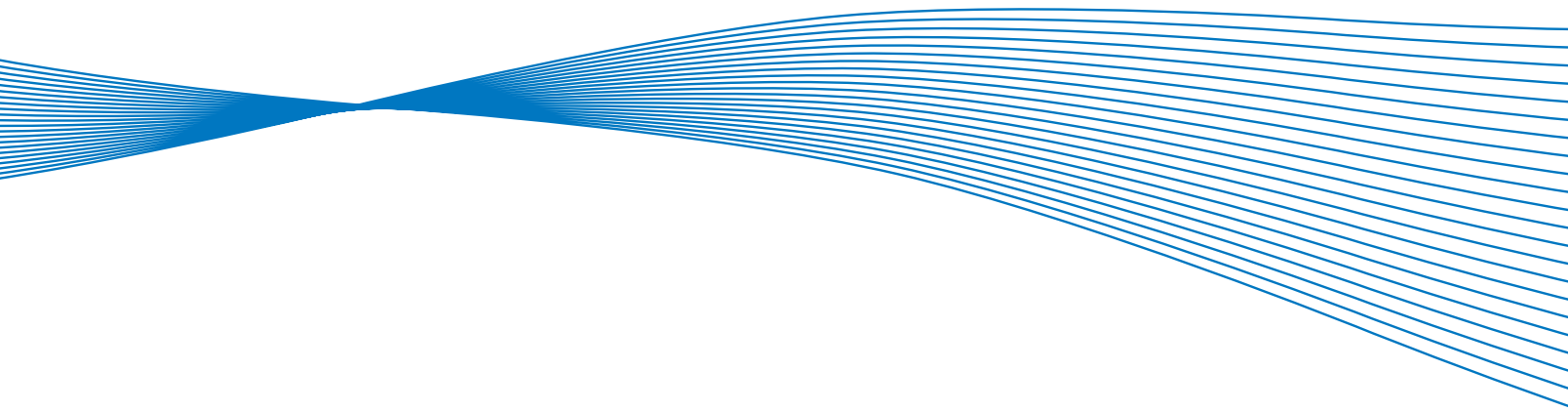

WE ARE DRIVES



VACON[®] X SERIES



THE TOUGHEST AC DRIVES ON THE PLANET!

The Vacon X Series Drives are designed for the REAL world - a world that is not gentle or forgiving to electronic devices. They have been designed to keep driving in harsh environments and are built from the ground up to survive hostile conditions and still be simple to use. They are built to be mounted where the work is, not hidden in another enclosure or room that adds costs and space.

ROBUST AND RELIABLE

The same enclosures that can survive in the harsh industrial world makes them ideal when cleanliness is extremely important, such as the Food and Beverage industry where high pressure washings are needed on a regular basis. The Vacon X Series drives, through 100 HP, exceed the specifications of their rated UL Type 4X / IP66 Indoor and Outdoor rated enclosures, each being able to withstand high pressure washdown of 1000 PSI from 12" away. The Vacon X Series drives are also packed with advanced control and operation features that make them the best choice for everything from simple, stand-alone applications to advanced system-level controls.

SIMPLE AND FLEXIBLE

The Vacon X Series drives also boast the easiest programming and operation in the industry. The

bright, clear, backlit display provides an easy to read and customizable view for operation and programming. The Vacon X Series keypad has large, well marked buttons to control all aspects of the drive operation and programming.

The Vacon X4 has the toughness and features to handle most industrial jobs with ease. If the application is more unique, the X5 accepts option boards, has a USB interface, fully coated PC boards for added protection and other advanced features such as a real-time-clock.

A tough enclosure, an easy to read display, simple programming and the confidence of knowing you can mount the drive almost anywhere make the Vacon X Series the only choice for the most demanding environments.



NEW TO VACON X SERIES

230VAC SINGLE PHASE INPUT

The VACON X4 and VACON X5 now feature a best in class, out-of-the-box, single phase 230VAC input product offering with standard output powers of 5HP, 10HP and 15HP (230V 3-Phase AC). These new offerings provide all the benefits of the VACON X Series family including the most robust UL Type 4X, Indoor/Outdoor, rated enclosure with the ease of use and flexibility you've come to know and trust.

NEW ENCLOSURE RATING FOR FRAME 5

Just when you thought the VACON X Series couldn't possibly stand up to any more of a beating, we go ahead and make the Frame 5 even more robust. From 125HP through 200HP, the VACON X Series can now be placed outside in the elements with the new UL Type 3R, Indoor/Outdoor rating. For the first time, EVERY VACON X Series can be placed outside in the elements, allowing for even greater mounting flexibility without having to spend even one cent more on installation costs.

VACON X4 / X5

Features	Description	Benefits
Robust Enclosure	The VACON X Series features a best in class UL Type 4X, Indoor/Outdoor certified enclosure through 100HP	<ul style="list-style-type: none"> • Reduced Installation Cost • High Reliability
Integrated Brake Resistor	Each VACON X Series includes a Brake resistor allowing it to better handle high inertial loads and warm up in cold conditions	<ul style="list-style-type: none"> • Reduced Installation Costs • Mount in Low Temperatures
Built-in Sequencer	The VACON X Series features a built-in multi-step sequencer that can replace a small PLC in many applications	<ul style="list-style-type: none"> • Reduced investment costs • Flexible application programming

WHAT'S IN IT FOR YOU

STANDARD VACON X SERIES FEATURES



TOUGHEST PACKAGING

The VACON X Series is the toughest drive on the market today. Featuring an incredibly robust design with (low failure rate), the VACON X Series can truly be mounted where it is needed the most.

- Thick injected foam and metal covers protect against bumps and misuse
- Withstands 1,000 PSI washdown from 6 inches away on models through 30 HP
- Withstands 1000 PSI washdown from 12 inches away on models through 100HP
- Mounts close to the motor to eliminate long motor lead problems



INDOOR OR OUTDOOR

Each drive in the VACON X Series features a built-in braking resistor that not only allows the VACON X Series to handle higher inertial loads out of the box, but allows it to warm itself up in even the coldest conditions. Add to this the standard UL-approved Outdoor Rating found on every frame size and you have a one-two punch that just can't be beat.

- UL Type 4X / IP66 Indoor and Outdoor rated enclosures through 100 HP
- UL Type 3R / IP55 Indoor and Outdoor rated enclosures for 125 HP and above
- Dynamic Braking resistors included as standard
- ARCTIC Mode maintains safe operating temperature in cold locations



EASY TO USE

The VACON X Series features a user-friendly keypad which makes operation simple. The easy-to-read display communicates operational status information as well as parameter names and settings in a clear, plain text, format making navigation and programming easier than ever.

- Simple intuitive programming with color coded buttons
- Multi-language display – no codes to learn
- Two parameter levels eases simple application programming
- Application Macros make set-up a breeze



VERSATILE PROGRAMMING

Not only does the VACON X Series feature a robust and reliable enclosure, it also brings with it a level of versatility to meet almost any application requirements. By including features such as Modbus RTU, a multi-step PLC-like sequencer and plenty of dedicated and programmable I/O, the VACON X Series helps to reduce the overall system investment costs.

- Operate from keypad, remote I/O, fieldbus communications or any combination
- Built-in 9-step PLC functions (25-step with X5)
- Modbus RTU as standard fieldbus communications

INTEGRATED USB PORT

The VACON X5 control platform includes a USB port as standard for functions like parameter saving, firmware updating and using the built-in data-logger function.

- Parameter Save / Recall
- Save parameter set to USB stick and upload to another drive
- Stored data easily opened with Microsoft Excel
- Ability to define custom file name (numbers or text)
- Easy firmware upgrades using standard USB memory stick
- Collect real time data and event logs



OPTION CARD SUPPORT

In an ever changing world, a drive must be ready to support newer technologies as well as maintain a level of compatibility with established technology. The VACON X5 easily walks this line through the addition of support for several communications option cards that include built-in 115V I/O and an encoder input for high demand applications.

- DeviceNet, Ethernet IP, Profibus and Modbus TCP option cards are available to supplement the built in Modbus RTU
- All option cards include five channels of 115VAC control inputs and offer a shaft mounted encoder interface
- An option card is available with a dedicated encoder interface



REAL-TIME CLOCK

By adding a real-time clock to the VACON X5, the information received from the drive is not only much more useful, but many of the functions in the drive are further expanded for greater time based control.

- Time and date stamped Fault Information
- Keeper Function — logs time-based data from external or internal signals
- Data read via serial communication or transferred to USB Memory Stick
- Control operation based on time-of-day. Separate weekday and weekend settings available
- Signals an event via text on the display or contact closure, independent of drive operation



ENHANCED PROGRAM SEQUENCER

The VACON X5 features an enhanced 25-step programmable sequencer that unlocks even more PLC-like capabilities than the 9-step sequencer of the VACON X4. This allows an unprecedented level of built-in control that helps to reduce investment costs and increase efficiency.

- Create up to 4 independant groups of steps for ultimate flexibility
- New loop and branch capabilities available
- Real Time Clock — time-of-day (TOD) enable function, allows programmed operation to specific periods of the day or week

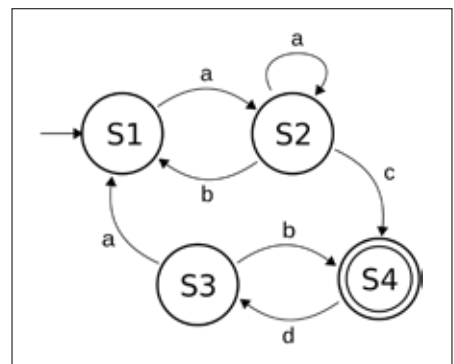

Terminal	Description
FWD	Run Forward Selection
REV	Run Reverse Selection
R/J	Run/Jog Selection
DI1	Digital Input 1
DI2	Digital Input 2
DI3	Digital Input 3
DI4	Digital Input 4
DI5	Digital Input 5
MOL	External Motor Overload
+24V	24V Bus for Digital Inputs
+10V	10V Bus for Analog Inputs
Vin1	Analog Input (Voltage)
Acom	Analog Common (Ground)
Cin+	Current Input
Cin-	Current Input
Imet	Analog Output (Current)

Terminal	Description
Acom	Analog Common (Ground)
Vmet	Analog Output (Voltage)
NO1	Relay 1 Normally Open
RC1	Relay 1 Common
NC1	Relay 1 Normally Closed
NO2	Relay 2 Normally Open
RC2	Relay 2 Common
NC2	Relay 2 Normally Closed
Dcom	Digital Common (Ground)
EN	Drive Enable Terminal
+24V	24V Bus for Digital Inputs
+24V	24V Bus for Digital Inputs
Dcom	Digital Common (Ground)
DO1	Digital Output 1
DO2	Digital Output 2
DOP	Pulse Train Digital Output

PRODUCT RANGE

VACON X SERIES 115 VAC 1-PH

Product Code		Motor Shaft Power and Current						Frame Size	Dimensions W x H x D (mm) W x H x D (in)	Weight (kg) Weight (lbs)
Vacon X4	Vacon X5	High Overload [150%]			Low Overload [120%]					
		HP	kW	Amps	HP	kW	Amps			
---	VACONX5C1S010C	0.5	0.37	2.2	1	0.75	4.2	T1A	221 x 306 x 216 8.72 x 12.01 x 8.49	6.35 14
VACONX4C1S010C	VACONX5C1S010C09	0.5	0.37	2.2	1	0.75	4.2	T0	165 x 241 x 155 6.5 x 9.47 x 6.08	3.85 8.5

VACON X SERIES 200-230 VAC 1-PH

Product Code		Motor Shaft Power and Current						Frame Size	Dimensions W x H x D (mm) W x H x D (in)	Weight (kg) Weight (lbs)
Vacon X4	Vacon X5	High Overload [150%]			Low Overload [120%]					
		HP	kW	Amps	HP	kW	Amps			
---	VACONX5C2S050C	3	2.2	9.6	5	4	15.2	T1A	221 x 306 x 216 8.72 x 12.01 x 8.49	6.35 14
---	VACONX5C2S100C	7.5	5.5	22	10	7.5	28	T2A	273 x 442 x 251 10.75 x 17.38 x 9.89	13.38 29.5
VACONX4C2S050C	---	3	2.2	9.6	5	4	15.2	T1	221 x 306 x 166 8.72 x 12.01 x 6.51	6.35 14
VACONX4C2S100C	---	7.5	5.5	22	10	7.5	28	T2	273 x 442 x 201 10.75 x 17.38 x 7.91	13.38 29.5
VACONX4C2S150C	VACONX5C2S150C	10	7.5	28	15	11	42	T3	286 x 513 x 314 11.19 x 20.19 x 11.73	22.68 50

VACON X SERIES 200-230 VAC 3-PH

Product Code		Motor Shaft Power and Current						Frame Size	Dimensions W x H x D (mm) W x H x D (in)	Weight (kg) Weight (lbs)
Vacon X4	Vacon X5	High Overload [150%]			Low Overload [120%]					
		HP	kW	Amps	HP	kW	Amps			
---	VACONX5C20010C	0.5	0.37	2.2	1	0.75	4.2	T1A	221 x 306 x 216 8.72 x 12.01 x 8.49	6.35 14
---	VACONX5C20020C	1	0.75	4.2	2	1.5	6.8			
---	VACONX5C20030C	2	1.5	6.8	3	2.2	9.6			
---	VACONX5C20050C	3	2.2	9.6	5	4	15.2			
---	VACONX5C20075C	5	4	15.2	7.5	5.5	22			
---	VACONX5C20100C	7.5	5.5	22	10	7.5	28	T2A	273 x 442 x 251 10.75 x 17.38 x 9.89	13.38 29.5
---	VACONX5C20150C	10	7.5	28	15	11	42			
VACONX4C20010C	VACONX5C20010C09	0.5	0.37	2.2	1	0.75	4.2	T0	165 x 241 x 155 6.5 x 9.47 x 6.08	3.85 8.5
VACONX4C20020C	VACONX5C20020C09	1	0.75	4.2	2	1.5	6.8			
VACONX4C20030C	VACONX5C20030C09	2	1.5	6.8	3	2.2	9.6			
VACONX4C20050C	VACONX5C20050C09	3	2.2	9.6	5	4	15.2	T1	221 x 306 x 166 8.72 x 12.01 x 6.51	6.35 14
VACONX4C20075C	VACONX5C20075C09	5	4	15.2	7.5	5.5	22			
VACONX4C20100C	VACONX5C20100C09	7.5	5.5	22	10	7.5	28	T2	273 x 442 x 201 10.75 x 17.38 x 7.91	13.38 29.5
VACONX4C20150C	VACONX5C20150C09	10	7.5	28	15	11	42			
VACONX4C20200C	VACONX5C20200C	15	11	42	20	15	54	T3	286 x 513 x 314 11.19 x 20.19 x 11.73	22.68 50
VACONX4C20250C	VACONX5C20250C	20	15	54	25	18.5	68			

VACON X SERIES 380-480 VAC 3-PH

Product Code		Motor Shaft Power and Current						Frame Size	Dimensions W x H x D (mm) W x H x D (in)	Weight (kg) Weight (lbs)
Vacon X4	Vacon X5	High Overload (150%)			Low Overload (120%)					
		HP	kW	Amps	HP	kW	Amps			
---	VACONX5C40010C	0.5	0.37	1.1	1	0.75	2.1	T1A 221 x 306 x 216 8.72 x 12.01 x 8.49	6.35 14	
---	VACONX5C40020C	1	0.75	2.1	2	1.5	3.4			
---	VACONX5C40030C	2	1.5	3.4	3	2.2	4.8			
---	VACONX5C40050C	3	2.2	4.8	5	4	7.6			
---	VACONX5C40075C	5	4	7.6	7.5	5.5	11			
---	VACONX5C40100C	7.5	5.5	11	10	7.5	14			
---	VACONX5C40150C	10	7.5	14	15	11	21			
---	VACONX5C40200C	15	11	21	20	15	27	T2A 273 x 442 x 251 10.75 x 17.38 x 9.89	13.38 29.5	
---	VACONX5C40250C	20	15	27	25	18.5	34			
---	VACONX5C40300C	25	18.5	34	30	22	40			
VACONX4C40010C	VACONX5C40010C09	0.5	0.37	1.1	1	0.75	2.1	T0 165 x 241 x 155 6.5 x 9.47 x 6.08	3.85 8.5	
VACONX4C40020C	VACONX5C40020C09	1	0.75	2.1	2	1.5	3.4			
VACONX4C40030C	VACONX5C40030C09	2	1.5	3.4	3	2.2	4.8			
VACONX4C40050C	VACONX5C40050C09	3	2.2	4.8	5	4	7.6	T1 221 x 306 x 166 8.72 x 12.01 x 6.51	6.35 14	
VACONX4C40075C	VACONX5C40075C09	5	4	7.6	7.5	5.5	11			
VACONX4C40100C	VACONX5C40100C09	7.5	5.5	11	10	7.5	14			
VACONX4C40150C	VACONX5C40150C09	10	7.5	14	15	11	21	T2 273 x 442 x 201 10.75 x 17.38 x 7.91	13.38 29.5	
VACONX4C40200C	VACONX5C40200C09	15	11	21	20	15	27			
VACONX4C40250C	VACONX5C40250C09	20	15	27	25	18.5	34			
VACONX4C40300C	VACONX5C40300C09	25	18.5	34	30	22	40	T3 286 x 513 x 314 11.19 x 20.19 x 11.73	22.68 50	
VACONX4C40400C	VACONX5C40400C	30	22	40	40	30	52			
VACONX4C40500C	VACONX5C40500C	40	30	52	50	37	65			
VACONX4C40600C	VACONX5C40600C	50	37	65	60	45	77	T4 326 x 745 x 351 12.84 x 29.35 x 13.8	43.1 95	
VACONX4C40750C	VACONX5C40750C	60	45	77	75	55	96			
VACONX4C41000C	VACONX5C41000C	75	55	96	100	75	124			
VACONX4C41250K	VACONX5C41250K	100	75	124	125	90	156	T5 461 x 1334 x 429 18.14 x 52.5 x 16.88	138.35 305	
VACONX4C41500K	VACONX5C41500K	125	90	156	150	110	180			
VACONX4C42000K	VACONX5C42000K	150	110	180	200	132	240			

VACON X SERIES 575 VAC 3-PH

Product Code		Motor Shaft Power and Current						Frame Size	Dimensions W x H x D (mm) W x H x D (in)	Weight (kg) Weight (lbs)
Vacon X4	Vacon X5	High Overload (150%)			Low Overload (120%)					
		HP	kW	Amps	HP	kW	Amps			
---	VACONX5C50010C	0.5	0.37	0.9	1	0.75	1.7	T1A 221 x 306 x 216 8.72 x 12.01 x 8.49	6.35 14	
---	VACONX5C50020C	1	0.75	1.7	2	1.5	2.7			
---	VACONX5C50030C	2	1.5	2.7	3	2.2	3.9			
---	VACONX5C50050C	3	2.2	3.9	5	4	6.1			
---	VACONX5C50075C	5	4	6.1	7.5	5.5	9			
---	VACONX5C50100C	7.5	5.5	9	10	7.5	11			
---	VACONX5C50150C	10	7.5	11	15	11	17			
---	VACONX5C50200C	15	11	17	20	15	22	T2A 273 x 442 x 251 10.75 x 17.38 x 9.89	13.38 29.5	
---	VACONX5C50250C	20	15	22	25	18.5	27			
---	VACONX5C50300C	25	18.5	27	30	22	32			
VACONX4C50010C	VACONX5C50010C09	0.5	0.37	0.9	1	0.75	1.7	T1 221 x 306 x 166 8.72 x 12.01 x 6.51	6.35 14	
VACONX4C50020C	VACONX5C50020C09	1	0.75	1.7	2	1.5	2.7			
VACONX4C50030C	VACONX5C50030C09	2	1.5	2.7	3	2.2	3.9			
VACONX4C50050C	VACONX5C50050C09	3	2.2	3.9	5	4	6.1	T2 273 x 442 x 201 10.75 x 17.38 x 7.91	13.38 29.5	
VACONX4C50075C	VACONX5C50075C09	5	4	6.1	7.5	5.5	9			
VACONX4C50100C	VACONX5C50100C09	7.5	5.5	9	10	7.5	11			
VACONX4C50150C	VACONX5C50150C09	10	7.5	11	15	11	17	T3 286 x 513 x 314 11.19 x 20.19 x 11.73	22.68 50	
VACONX4C50200C	VACONX5C50200C09	15	11	17	20	15	22			
VACONX4C50250C	VACONX5C50250C09	20	15	22	25	18.5	27			
VACONX4C50300C	VACONX5C50300C09	25	18.5	27	30	22	32	T4 326 x 745 x 351 12.84 x 29.35 x 13.8	43.1 95	
VACONX4C50400C	VACONX5C50400C	30	22	32	40	30	41			
VACONX4C50500C	VACONX5C50500C	40	30	41	50	37	52			
VACONX4C50600C	VACONX5C50600C	50	37	52	60	45	62	T5 461 x 1334 x 429 18.14 x 52.5 x 16.88	138.35 305	
VACONX4C50750C	VACONX5C50750C	60	45	62	75	55	77			
VACONX4C51000C	VACONX5C51000C	75	55	77	100	75	99			
VACONX4C51250K	VACONX5C51250K	100	75	99	125	90	125	T5 461 x 1334 x 429 18.14 x 52.5 x 16.88	138.35 305	
VACONX4C51500K	VACONX5C51500K	125	90	125	150	110	144			
VACONX4C52000K	VACONX5C52000K	150	110	144	200	132	192			

TYPE CODE KEY

VACON X5

C

4

0500

C

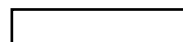

Product



Regional Configuration



Voltage Rating

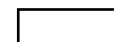

Power Rating



Enclosure Class

VACON X SERIES OPTIONS

OPTION	ORDER TYPECODE	NOTE
DeviceNet Option Card	X5DNET01	VACON X5 Only. Models with "09" suffix will not accept option cards
Ethernet IP Option Card	X5EIP01	
ModBus TCP/IP Option Card	X5MBTCP01	
ProfiBus Option Card	X5PROF01	
115 Vac and Encoder Feedback Option Card	X5OPT01	
Remote Keypad for Panel Mount Drives	XRKPM	Includes 12' Ribbon Cable VACON X4 and X5 - Frames 0-2
Remote Keypad for Wall Mount Drives	XRKWM	VACON X4 and X5 - Frames 0-2
Remote Keypad Mounting Kit	XRKMK	VACON X4 and X5 - Frames 3-5
DB Connection Kit	XDBKITS4	VACON X4 and X5 - Frame 4 Only
DB Connection Kit - Frame 5	XDBKITS5	VACON X4 and X5 - Frame 4 Only

VACON X4 AND VACON X5 SPECIFICATIONS

Environmental	Operating temperature	-10°C to +40°C (14°F to 104°F)			
	Storage temperature	-20°C to 65°C (-4°F to 149°F)			
	Humidity	0% to 95% non-condensing			
	Altitude	1,000 m (3,300 ft) without derating			
	Maximum vibration	Per EN50178: Frame Size 0 and 1 5G			
	Acoustic noise	80 dba sound power at 1 m (3 ft)			
	Cooling	1 - 5 HP models: Natural convection 7.5 - 200 HP: Forced air (temperature controlled external fan)			
	Protection Level	1 - 100 HP models: UL Type 4X / IP66 Indoor or Outdoor Use (1 - 30 HP models: 1,000 psi water spray at 6 inches) 125 - 200 HP models: UL Type 3R / IP55			
	Agency approvals	UL, cUL, CE			
Electrical	Input voltage	115 Vac 1 phase, +/- 15%	230 Vac models	460 Vac models	575 Vac models
		200-230 Vac, 3 phase, +/- 15%	406 Vdc	814 Vdc	1017 Vdc
		380-460 Vac, 3 phase, +/- 15%	388 Vdc	776 Vdc	970 Vdc
		575 Vac, 3 phase, +/- 15%	199 Vdc	397 Vdc	497 Vdc
	Line frequency	50 / 60 Hz +/- 2 Hz			
	Source kVA (maximum)	10 times the unit rated kVA (65kA maximum)			
	DC bus voltage for:	115 Vac models	230 Vac models	460 Vac models	575 Vac models
	Overvoltage trip	406 Vdc	406 Vdc	814 Vdc	1017 Vdc
	Dynamic brake activation	388 Vdc	388 Vdc	776 Vdc	970 Vdc
Normal undervoltage (UV) trip	199 Vdc	199 Vdc	397 Vdc	497 Vdc	
Control system	V/Hz or Sensorless Vector Control (SVC) Carrier frequency = 1 to 16 kHz programmable				
Output voltage	0 to 100% of line voltage, 3 phase				
Overload capacity	120% of rated RMS current for 60 seconds (Normal Duty rating) 150% of rated RMS current for 60 seconds (Heavy Duty rating)				
Frequency output	Range: 0.1 - 400Hz; Stability: 0.1Hz, 0.1% analog over 24 hours +/- 10°C				
Control Features	DC holding/injection braking	At start, stop, by frequency with adjustable current level and time or continuous DC injection by digital input			
	Current limit	Four-quadrant adjustable from 5 to 150%			
	Speed ramps	Primary and alternate adjustable from 0.1 to 3200.0 seconds			
	Voltage boost	Adjustable fixed boost or adjustable auto boost			
	Voltage characteristic	V/Hz - Linear, pump, fan or 2-piece linear; Sensorless Vector			
	Timed overload	Adjustable inverse time trip (shear pin, 30 sec, 60 sec, 5 minutes) for standard or inverter-duty motors			
	Protective features	Overcurrent, Overvoltage fault, ground fault, short circuit, Dynamic Brake overload, drive temperature, power wiring fault. Drive-timed overload, input voltage quality, overvoltage ride-through			
	Program Sequence Controller	X4: 9-step, PLC-type functionality to control speed, direction and ramp times based on time, analog input, digital input or pulse count. X5: 25-step, PLC-type functionality that can control speed, direction and ramps based on time, analog input, digital input, or pulse input. Conditional branching, addressable outputs and real time operations possible.			
	PI and PID Feedback	X4: PI Process control available with the use of a customer supplied transducer, either 0-10Vdc, 4-20mA or optical encoder input to the drive. X5: Process control available with the use of a customer supplied transducer, either 0-10Vdc, 4-20mA or optical encoder input to the drive. Includes an optional sleep mode, activated when the loop is satisfied.			

WE ARE DRIVES



VACON[®] X5 HAZLO



DESIGNED FOR THE REAL WORLD

The new VACON X5 HazLo is a first in the world of AC Drives. Designed as an out of the box solution, the VACON X5 HazLo builds on the very foundations of a world class harsh duty drive to create a unique solution for Hazardous Locations. The VACON X5 HazLo has been certified for Class I, II and III; Division 2 locations suitable for several applications in Refineries, Graineries, Gypsum Processing Facilities or anywhere else where ignitable substances are not normally present, but may exist in unlikely scenarios.*

UNIQUE ENCLOSURE

As the VACON X5 HazLo has been designed to meet the requirements for Division 2 Hazardous Locations, there is no longer a need for the bulky, heavy and expensive UL Type 7 Enclosure. Instead, what's left is a UL Type 4X Enclosure that's a perfect fit for your application. Because cooling is no longer a concern, the VACON X5 HazLo provides even greater mounting flexibility due to being much smaller and lighter than Division 1 solutions.

PROVEN USABILITY

The ability to easily program and control a drive from the keypad is often overlooked in Hazardous Location applications due to the drive being installed in an enclosure where adding a viewing window or keypad interface is often very expensive. By using the VACON X5 HazLo in these Division 2 applications, a user is given complete access to all of the functions of the keypad. In addition, having a drive that is simple to program and provides clear and concise visual information ensures that the drive is operating as intended at all times.

VACON® X5 HazLo® AC DRIVE

Features	Description	Benefits
Robust Enclosure	UL Type 4X environmental ratings for Indoor/Outdoor certified enclosure. No derating needed. No purging needed.	<ul style="list-style-type: none"> • Compact size provides cost effective installation • No cooling concerns as an additional enclosure box is not needed
Integrated Brake Resistor	Includes a Brake resistor allowing it to better handle high inertial loads and warm up in cold conditions.	<ul style="list-style-type: none"> • Reduced Installation Costs • Mount in Low Temperatures
Built-in Sequencer	Features a built-in multi-step sequencer that can replace a small PLC in many applications.	<ul style="list-style-type: none"> • Reduced investment costs • Flexible application programming
Standards	UL - ANSI/ISA 12.12.01, 2007, cUL - CAN/CSA C22.2 No. 157-M1987, CAN/CSA C22.2 No. 157	



VACON® X5 HazLo® APPROVED HAZARDOUS LOCATIONS

Classes	Groups	Division 2
I: Gasses, vapors and liquids	A: Acetylene B: Hydrogen, etc. C: Ether, etc. D: Hydrocarbons, fuels, solvents, etc.	Not normally present in an explosive concentration (but may accidentally exist)
II: Dusts	F: Carbon dusts (some are conductive and all are explosive) G: Flour, starch, grain, combustible plastic or chemical	Dust not normally suspended in an ignitable concentration (but may accidentally exist). Dust layers are present.
III: Fibers and flyings	Textiles, wood-working, etc. (easily ignitable, but not likely to be explosive)	Stored or handled in storage (exclusive of manufacturing)

Source: OSHA.gov

VACON® X5 HazLo® AC DRIVE APPLICATIONS

VACON® X5 HazLo® AC Drives are ideal for a variety of applications such as:

Applications in Class 1, Div 2 locations:

- Petroleum refineries, and gasoline storage and dispensing areas.
- Dry cleaning plants where vapors from cleaning fluids can be present.
- Spray finishing areas.
- Aircraft hangars and fuel servicing areas.
- Utility gas plants and operations involving storage and handling of liquefied petroleum gas or natural gas.
- Water and wastewater facilities.

Applications in Class 2 and Class 3, Div 2 locations:

- Grain elevators; flour and feed mills.
- Producers of plastics, medicines and fireworks.
- Producers of starch or candies.
- Spice-grinding plants, sugar plants and cocoa plants.
- Coal preparation plants and other carbon handling or processing areas.
- Textile mills, cotton gins; cotton seed mills, flax processing plants and plants that shape, pulverize or cut wood and create sawdust.

Source: OSHA.gov

X5 HAZLO I/O

Terminal	Description
FWD	Run Forward Selection
REV	Run Reverse Selection
R/J	Run/Jog Selection
DI1	Digital Input 1
DI2	Digital Input 2
DI3	Digital Input 3
DI4	Digital Input 4
DI5	Digital Input 5
MOL	External Motor Overload
+24V	24V Bus for Digital Inputs
+10V	10V Bus for Analog Inputs
Vin1	Analog Input (Voltage)
Acom	Analog Common (Ground)
Cin+	Current Input
Cin-	Current Input
Imet	Analog Output (Current)

Terminal	Description
Acom	Analog Common (Ground)
Vmet	Analog Output (Voltage)
N01	Relay 1 Normally Open
RC1	Relay 1 Common
NC1	Relay 1 Normally Closed
N02	Relay 2 Normally Open
RC2	Relay 2 Common
NC2	Relay 2 Normally Closed
Dcom	Digital Common (Ground)
EN	Drive Enable Terminal
+24V	24V Bus for Digital Inputs
+24V	24V Bus for Digital Inputs
Dcom	Digital Common (Ground)
D01	Digital Output 1
D02	Digital Output 2
DOP	Pulse Train Digital Output

PRODUCT RANGE

VACON X5 HAZLO 480V 3-PH

Product Code		Motor Shaft Power and Current						Frame Size	Dimensions W x H x D (mm) W x H x D (in)	Weight (kg) Weight (lbs)
		High Overload (150%)			Low Overload (120%)					
Safety Yellow	Stainless Steel	HP	kW	Amps	HP	kW	Amps			
VACONX5C40400X	VACONX5C40400Y	30	22	40	40	30	52	T3	286 x 513 x 314 11.19 x 20.19 x 11.73	22.68 50
VACONX5C40500X	VACONX5C40500Y	40	30	52	50	37	65			
VACONX5C40600X	VACONX5C40600Y	50	37	65	60	45	77	T4	326 x 745 x 351 12.84 x 29.35 x 13.8	43.1 95
VACONX5C40750X	VACONX5C40750Y	60	45	77	75	55	96			
VACONX5C41000X	VACONX5C41000Y	75	55	96	100	75	124			

VACON X5 HAZLO 575V 3-PH

Product Code		Motor Shaft Power and Current						Frame Size	Dimensions W x H x D (mm) W x H x D (in)	Weight (kg) Weight (lbs)
		High Overload (150%)			Low Overload (120%)					
Safety Yellow	Stainless Steel	HP	kW	Amps	HP	kW	Amps			
VACONX5C50400X	VACONX5C50400Y	30	22	32	40	30	41	T3	286 x 513 x 314 11.19 x 20.19 x 11.73	22.68 50
VACONX5C50500X	VACONX5C50500Y	40	30	41	50	37	52			
VACONX5C50600X	VACONX5C50600Y	50	37	52	60	45	62	T4	326 x 745 x 351 12.84 x 29.35 x 13.8	43.1 95
VACONX5C50750X	VACONX5C50750Y	60	45	62	75	55	77			
VACONX5C51000X	VACONX5C51000Y	75	55	77	100	75	99			

TYPE CODE KEY

VACON X5

C

4

0500

X

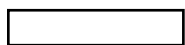

Product



Configuration



Voltage
Rating

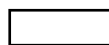

Power
Rating



Enclosure
Class

OPTION	ORDER TYPECODE	NOTE
115 Vac and Encoder Feedback Option Card	X5OPT01X	Must include the "X" suffix for the VACON X5 HazLo
Ethernet IP Option Card	X5EIP01X	
DeviceNet Option Card	X5DNET01X	
ModBus TCP/IP Option Card	X5MBTCP01X	
ProfiBus Option Card	X5PROFI01X	

VACON X5 HAZLO SPECIFICATIONS

Environmental	Operating temperature	-10°C to +40°C (14°F to 104°F)			
	Storage temperature	-20°C to 65°C (-4°F to 149°F)			
	Humidity	0% to 95% non-condensing			
	Altitude	1,000 m (3,300 ft) without derating			
	Maximum vibration	Per EN50178: Frame Size 0 and 1 5G			
	Acoustic noise	80 dba sound power at 1 m (3 ft)			
	Cooling	1 - 5 HP models: Natural convection 7.5 - 200 HP: Forced air (temperature controlled external fan)			
	Protection Level	1 - 100 HP models: UL Type 4X / IP66 Indoor or Outdoor Use (1 - 30 HP models: 1,000 psi water spray at 6 inches) 125 - 200 HP models: UL Type 3R / IP55			
	Agency approvals	UL, cUL			
Electrical	Input voltage	115 Vac 1 phase, +/- 15%	1 HP		
		200-230 Vac, 3 phase, +/- 15%	1-25 HP		
		380-460 Vac, 3 phase, +/- 15%	1-200 HP		
		575 Vac, 3 phase, +/- 15%	1-200 HP		
	Line frequency	50 / 60 Hz +/- 2 Hz			
	Source kVA (maximum)	10 times the unit rated kVA (65kA maximum)			
	DC bus voltage for:	115 Vac models	230 Vac models	460 Vac models	575 Vac models
	Overvoltage trip	406 Vdc	406 Vdc	814 Vdc	1017 Vdc
	Dynamic brake activation	388 Vdc	388 Vdc	776 Vdc	970 Vdc
	Normal undervoltage (UV) trip	199 Vdc	199 Vdc	397 Vdc	497 Vdc
Control system	V/Hz or Sensorless Vector Control (SVC) Carrier frequency = 1 to 16 kHz programmable				
Output voltage	0 to 100% of line voltage, 3 phase				
Overload capacity	120% of rated RMS current for 60 seconds (Normal Duty rating) 150% of rated RMS current for 60 seconds (Heavy Duty rating)				
Frequency output	Range: 0.1 - 400Hz; Stability: 0.1Hz, 0.1% analog over 24 hours +/- 10°C				
Control Features	DC holding/injection braking	At start, stop, by frequency with adjustable current level and time or continuous DC injection by digital input			
	Current limit	Four-quadrant adjustable from 5 to 150%			
	Speed ramps	Primary and alternate adjustable from 0.1 to 3200.0 seconds			
	Voltage boost	Adjustable fixed boost or adjustable auto boost			
	Voltage characteristic	V/Hz - Linear, pump, fan or 2-piece linear; Sensorless Vector			
	Timed overload	Adjustable inverse time trip (shear pin, 30 sec, 60 sec, 5 minutes) for standard or inverter-duty motors			
	Protective features	Overcurrent, Overvoltage fault, ground fault, short circuit, Dynamic Brake overload, drive temperature, power wiring fault. Drive-timed overload, input voltage quality, overvoltage ridethrough			
	Program Sequence Controller	X4: 9-step, PLC-type functionality to control speed, direction and ramp times based on time, analog input, digital input or pulse count. X5: 25-step, PLC-type functionality that can control speed, direction and ramps based on time, analog input, digital input, or pulse input. Conditional branching, addressable outputs and real time operations possible.			
	PI and PID Feedback	X4: PI Process control available with the use of a customer supplied transducer, either 0-10Vdc, 4-20mA or optical encoder input to the drive. X5: Process control available with the use of a customer supplied transducer, either 0-10Vdc, 4-20mA or optical encoder input to the drive. Includes an optional sleep mode, activated when the loop is satisfied.			

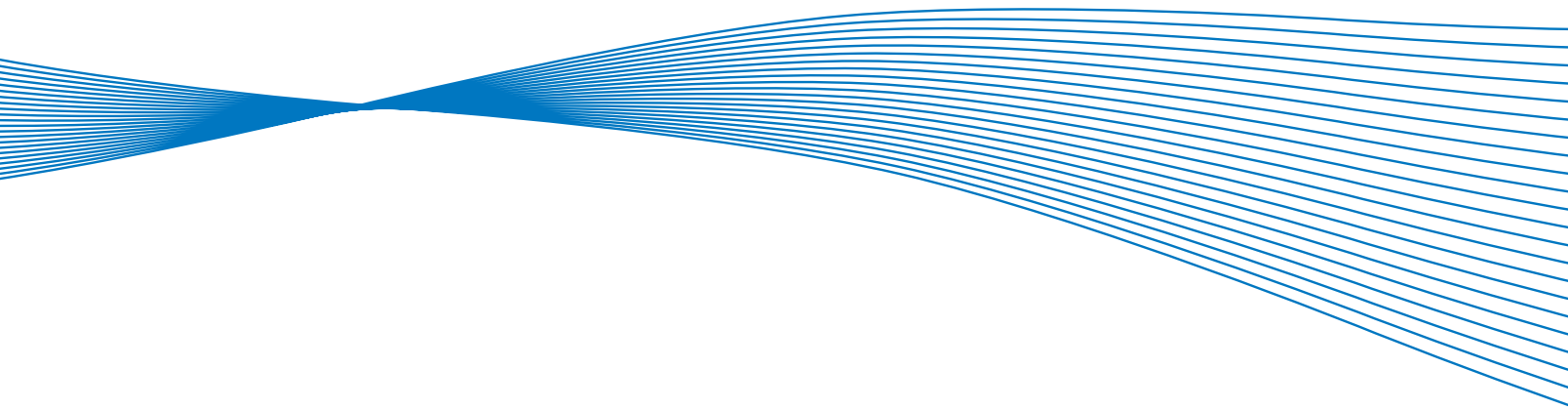

WE ARE DRIVES



VACON[®] NXS



FR4

FR5

FR6

FR7

FR8

FR9

THE RELIABLE CHOICE

The VACON® NXS is a compact AC drive in the power range of 0.50—250 HP (0.55—190kW) and supply voltages of 208—690 V for heavy use in machines, buildings and all branches of industry.

The VACON® NXS is the drive that does it all and then some. No job is too simple or too complex for the seven built-in application packages to solve. The Vacon NX also has several free task specific applications available to make even the most demanding jobs that much quicker to start up.

The VACON® NXS features a modular design that offers several advantages for any installation. The robust power module is designed for efficient cooling and features a snap-on fan unit that is simple to remove and replace. The control box, found on every VACON® NXS drive, is designed to safely separate the control terminals from the power terminals. This modular design also allows the VACON® NXS to be field upgraded to a UL TYPE 12/IP55 enclosure without the need to increase the footprint of the drive.

FEATURES

- Easy to use display panel
- Interactive programming with Start-Up Wizard
- Versatile All-in-One Package
- PID controller and PFC for 1-5 pumps
- Special applications available (water application package, high speed, etc.)
- Five slots for control boards (2 basic boards and 3 option boards)
- High switching frequency, low noise
- Steady state speed error < 1%
- Low torque ripple
- Starting torque > 200%, depending on AC drive sizing
- Suitable for multi-motor applications



INTUITIVE INTERFACE

- Plain Text Display
- Common human interface across all frame sizes
- Multiple language packs for many countries
- Seven built in application packages for easy commissioning



- Simple programming
- Languages for many countries
- Reduces start up time

ULTIMATE FLEXIBILITY

- UL Type 1/IP21 and UL Type 12/IP54 in the same footprint
- Many free specialty application programs
- Built-in AC Line Reactors standard for every frame size
- Five option card slots for communications and additional I/O
- Flange mounting and remote keypad mounting kits available



- Reduces investment costs
- One drive for many applications
- Protection against incoming power spikes
- Mount on a wall or in a cabinet

VACON NX CONTROL UNIT

The Vacon NX Family offers a high-performance control platform for all demanding drive applications. There are five slots (A, B, C, D and E) for I/O boards, and a suitable board can be selected for each slot (see table below).

The Vacon NX Family drives are delivered with OPT-A1 and OPT-A2 boards if the I/O is not specified. In many countries, boards OPT-A1 and OPT-A3 are used as standard I/O as the galvanically isolated thermistor input is often required.

Removable terminals, snap-in card installation, automatic card identification and instructions on the drive help making quick connections. If necessary, the inputs, outputs and fieldbus boards can be added in the field. The Vacon NX Family is simply the most flexible frequency converter series on the market.

An external +24 V supply option enables communication with the control unit even if the mains supply is switched off (e.g. fieldbus communication and parameter settings).



OPTION BOARDS

Type	Card slot					Suitability		I / O signal																	Note				
	A	B	C	D	E	NXS	NXP	DI	DO	DI	AI	AI	AO	AO	RO	RO	+10V _{ref}	Therm	+24V/pt100	42-240 VAC input	DI/DO	DI/DO	DI	Resolver		Out +5V/ +15V/ +24V	Out +15V/ +24V	Out +5V/ +12V/ +15V	
Basic I/O cards (OPT-A)																													
OPT-A1								6	1		2		1																
OPT-A2															2														
OPT-A3															1	1		1											
OPT-A4								2															3/0			1			
OPT-A5								2														3/0				1			
OPT-A8								6	1		2		1					1		2									1)
OPT-A9								6	1		2		1					1		2									2.5 mm ² terminals
OPT-AE									2													3/0				1			DO = Divider+Direction
I/O expander cards (OPT-B)																													
OPT-B1									6										1										Selectable DI/DO
OPT-B2														1	1		1												
OPT-B4											1		2						1										2)
OPT-B5																3													
OPT-B8																			1	3									
OPT-B9								2										1			5								
OPT-BB								2															0/2	2			1		Sin/Cos+EnDat
OPT-BC																						3/3							Encoder out=Resolver simulation
OPT-BE																													EnDat/SSI
Fieldbus cards (OPT-C)																													
OPT-C2																													Modbus RTU
OPT-C3																													
OPT-C4																													
OPT-C5																													
OPT-C6																													
OPT-C7																													
OPT-C8																													Modbus RTU
OPT-CG																													
OPT-CI																													
OPT-CJ																													
OPT-CP																													
OPT-CQ																													

NOTES: Allowed slots for the board are marked in blue.

1) analogue signals galvanically isolated as a group

2) analogue signals galvanically isolated separately

The mechanical design is extremely compact. The UL Type 12 units in particular are the smallest AC drives on the market. All units are suitable for both wall and enclosure mounting with all necessary components: integrated EMC filters, AC chokes, cable protection, dust and water protection. The effective super-cooling principle allows high ambient temperatures and high switching frequencies without derating.

PRODUCT RANGE

VACON NXS 208-240V, 50/60HZ, 3~

Product Code For UL Type 12, replace '2' with '5', e.g. NXS00042A5H1....	Motor Shaft Power and Current						Frame Size	Dimensions W x H x D (mm) W x H x D (in)	Weight (kg) Weight (lbs)
	High Overload (150%)			Low Overload (110%)					
	Power (HP)	Power (kW)	I _H (A)	Power (HP)	Power (kW)	I _L (A)			
NXS 0004	2A2H1SSSA1A2	0.75	0.55	3.7	1	0.75	4.8	FR4 128.01 x 292.1 x 189.99 5.04 x 11.50 x 7.48	4.989 11
NXS 0007	2A2H1SSSA1A2	1	0.75	4.8	1.5	1.1	6.6		
NXS 0008	2A2H1SSSA1A2	1.5	1.1	6.6	2	1.5	7.8		
NXS 0011	2A2H1SSSA1A2	2	1.5	7.8	3	2.2	11		
NXS 0012	2A2H1SSSA1A2	3	2.2	11	4	3	12.5		
NXS 0017	2A2H1SSSA1A2	4	3	12.5	5	4	17.5	FR5 144.01 x 390.9 x 214.12 5.67 x 15.39 x 8.43	8.164 18
NXS 0025	2A2H1SSSA1A2	5	4	17.5	7.5	5.5	25		
NXS 0031	2A2H1SSSA1A2	7.5	5.5	25	10	7.5	31		
NXS 0048	2A2H1SSSA1A2	10	7.5	31	15	11	48	FR6 195.07 x 518.92 x 236.98 7.68 x 20.43 x 9.33	18.597 41
NXS 0061	2A2H1SSSA1A2	15	11	48	20	15	61		
NXS 0075	2A2H0SSSA1A2	20	15	61	25	18.5	75	FR7 236.98 x 591.05 x 257.04 9.33 x 23.27 x 10.12	34.926 77
NXS 0088	2A2H0SSSA1A2	25	18.5	75	30	22	88		
NXS 0114	2A2H0SSSA1A2	30	22	88	40	30	114		
NXS 0140	2A2H0SSSA1A2	40	30	105	50	37	140	FR8 291.08 x 757.93 x 343.91 11.46 x 29.84 x 13.54	58.059 128
NXS 0170	2A2H0SSSA1A2	50	37	140	60	45	170		
NXS 0205	2A2H0SSSA1A2	60	45	170	75	55	205		
NXS 0261	2A2H0SSFA1A2	75	55	205	100	75	261	FR9 480.06 x 1,150.11 x 361.95 18.90 x 45.28 x 14.25	146.056 322
NXS 0300	2A2H0SSFA1A2	100	75	245	125	90	300		

VACON NXS 380-500V, 50/60HZ, 3~

Product Code For UL Type 12, replace '2' by '5', e.g. NXS00035A5H1....	Motor Shaft Power and Current						Frame Size	Dimensions W x H x D (mm) W x H x D (in)	Weight (kg) Weight (lbs)
	High Overload (150%)			Low Overload (110%)					
	Power (HP)	Power (kW)	I _H (A)	Power (HP)	Power (kW)	I _L (A)			
NXS 0003	5A2H1SSSA1A2	1	0.75	2.2	1.5	1.1	3.3	FR4 128.01 x 292.1 x 189.99 5.04 x 11.50 x 7.48	4.989 11
NXS 0004	5A2H1SSSA1A2	1.5	1.1	3.3	2	1.5	4.3		
NXS 0005	5A2H1SSSA1A2	2	1.5	4.3	3	2.2	5.6		
NXS 0007	5A2H1SSSA1A2	3	2.2	5.6	5	3	7.6		
NXS 0009	5A2H1SSSA1A2	5	3	7.6	5	4	9		
NXS 0012	5A2H1SSSA1A2	5	4	9	7.5	5.5	12	FR5 144.01 x 390.9 x 214.12 5.67 x 15.39 x 8.43	8.164 18
NXS 0016	5A2H1SSSA1A2	7.5	5.5	12	10	7.5	16		
NXS 0022	5A2H1SSSA1A2	10	7.5	16	15	11	23		
NXS 0031	5A2H1SSSA1A2	15	11	23	20	15	31	FR6 195.07 x 518.92 x 236.98 7.68 x 20.43 x 9.33	18.597 41
NXS 0038	5A2H1SSSA1A2	20	15	31	25	18.5	38		
NXS 0045	5A2H1SSSA1A2	25	18.5	38	30	22	46		
NXS 0061	5A2H1SSSA1A2	30	22	46	40	30	61	FR7 236.98 x 591.05 x 257.04 9.33 x 23.27 x 10.12	34.926 77
NXS 0072	5A2H0SSSA1A2	40	30	61	50	37	72		
NXS 0087	5A2H0SSSA1A2	50	37	72	60	45	87		
NXS 0105	5A2H0SSSA1A2	60	45	87	75	55	105	FR8 291.08 x 757.93 x 343.91 11.46 x 29.84 x 13.54	58.059 128
NXS 0140	5A2H0SSSA1A2	75	55	105	100	75	140		
NXS 0168	5A2H0SSSA1A2	100	75	140	125	90	170		
NXS 0205	5A2H0SSSA1A2	125	90	170	150	110	205	FR9 480.06 x 1,150.11 x 361.95 18.90 x 45.28 x 14.25	146.056 322
NXS 0261	5A2H0SSFA1A2	150	110	205	200	132	261		
NXS 0300	5A2H0SSFA1A2	200	132	245	200	160	300		

PRODUCT RANGE

VACON NXS 525-690V, 50/60HZ, 3~

Product Code For UL Type 12, replace '2' by '5', e.g. NXS00035A5H1....			Motor Shaft Power and Current						Frame Size	Dimensions W x H x D (mm) W x H x D (in)	Weight (kg) Weight (lbs)
			High Overload (150%)			Low Overload (110%)					
			Power (HP)	Power (kW)*	I _L (A)	Power (HP)	Power (kW)*	I _L (A)			
NXS	0004	6A2L0SSSA1A2	2	1.5	3.2	3	2.2	4.5	FR6	195.07 x 518.92 x 236.98 7.68 x 20.43 x 9.33	18.597 41
NXS	0005	6A2L0SSSA1A2	3	2.2	4.5	-	3	5.5			
NXS	0007	6A2L0SSSA1A2	-	3	5.5	5	4	7.5			
NXS	0010	6A2L0SSSA1A2	5	4	7.5	7.5	5.5	10			
NXS	0013	6A2L0SSSA1A2	7.5	5.5	10	10	7.5	13.5			
NXS	0018	6A2L0SSSA1A2	10	7.5	13.5	15	11	18			
NXS	0022	6A2L0SSSA1A2	15	11	18	20	15	22			
NXS	0027	6A2L0SSSA1A2	20	15	22	25	18.5	27			
NXS	0034	6A2L0SSSA1A2	25	18.5	27	30	22	34			
NXS	0041	6A2L0SSSA1A2	30	22	34	40	30	41			
NXS	0052	6A2L0SSSA1A2	40	30	41	50	37	52	FR7	236.98 x 591.05 x 257.04 9.33 x 23.27 x 10.12	34.926 77
NXS	0062	6A2L0SSSA1A2	50	37	52	60	45	62	FR8	291.08 x 757.93 x 343.91 11.46 x 29.84 x 13.54	58.059 128
NXS	0080	6A2L0SSSA1A2	60	45	62	75	55	80			
NXS	0100	6A2L0SSSA1A2	75	55	80	100	75	100			
NXS	0125	6A2L0SSSA1A2	100	75	100	125	90	125			
NXS	0144	6A2L0SSFA1A2	125	90	125	150	110	144	FR9	480.06 x 1,150.11 x 361.95 18.90 x 45.28 x 14.25	146.056 322
NXS	0170	6A2L0SSFA1A2	150	110	144	-	132	170			
NXS	0208	6A2L0SSFA1A2	-	132	170	200	160	208			

* Power ratings in kW are at 575V. Contact your local Vacon Sales Representative for 690V ratings.



NXS KEYPAD

The text display with functions such as multi-monitoring, parameter copy, parameter backup and start-up wizard makes commissioning easy.

High-power VACON® NXS drives are also available in a compact standalone IP21 or IP54 enclosure. These units are designed for use in applications where the drive has to be compact and easy to install.

The VACON® NXS standalone drives are fully enclosed at the factory and are ready for immediate installation. The drive has integrated fuses as standard and no extra protections are required by the drive. It is also possible to equip the drive with an optional integrated load switch, which further simplifies handling in the field.

VACON NXS 380-500V, 50/60HZ, 3~

Product Code For UL Type 12, replace '2' by '5', e.g. NXS00035A5H1....	Motor Shaft Power and Current						Frame Size	Dimensions W x H x D (mm) W x H x D (in)	Weight (kg) Weight (lbs)
	High Overload (150%)			Low Overload (110%)					
	Power (HP)	Power (kW)	I _H (A)	Power (HP)	Power (kW)	I _L (A)			
NXS 0385 5A2L0SSAA1A2	200	160	300	300	200	385	FR10 595 x 2018 x 602 23.425 x 79.448 x 23.700	340 749.57	
NXS 0460 5A2L0SSAA1A2	300	200	385	350	250	460			
NXS 0520 5A2L0SSAA1A2	350	250	460	450	250	520			
NXS 0590 5A2L0SSAA1A2	450	250	520	500	315	590	FR11 794 x 2018 x 602 31.259 x 79.448 x 23.700	470 1,036.17	
NXS 0650 5A2L0SSAA1A2	500	315	590	550	355	650			
NXS 0730 5A2L0SSAA1A2	550	355	650	600	400	730			

VACON NXS 525-690V, 50/60HZ, 3~

Product Code For UL Type 12, replace '2' by '5', e.g. NXS00035A5H1....	Motor Shaft Power and Current						Frame Size	Dimensions W x H x D (mm) W x H x D (in)	Weight (kg) Weight (lbs)
	High Overload (150%)			Low Overload (110%)					
	Power (HP)	Power (kW)	I _H (A)	Power (HP)	Power (kW)	I _L (A)			
NXS 0261 6A2L0SSAA1A2	200	200	208	250	250	261	FR10 595 x 2018 x 602 23.425 x 79.448 x 23.700	340 749.57	
NXS 0325 6A2L0SSAA1A2	250	250	261	300	315	325			
NXS 0385 6A2L0SSAA1A2	300	315	325	400	355	385			
NXS 0416 6A2L0SSAA1A2	400	355	385	450	400	416			
NXS 0460 6A2L0SSAA1A2	450	400	416	*	450	460	FR11 794 x 2018 x 602 31.259 x 79.448 x 23.700	470 1,036.17	
NXS 0502 6A2L0SSAA1A2	*	450	460	500	500	502			
NXS 0590 6A2L0SSAA1A2	500	500	502	550	560	590			

HARDWARE CONFIGURATIONS, STANDALONE UNITS

FUNCTION	AVAILABILITY
IP21 / UL Type 1	Standard
IP54 (FR10 only) / UL Type 12	Optional (H: +20mm)
Integrated fuses	Standard
Integrated load switch	Optional
EMC filtering L	Standard
EMC filtering T	Optional
Integrated brake chopper (cabling top entry)	Optional (H: +122 mm)



FR10



FR11

TECHNICAL DATA

Mains connection	Input voltage U_{in}	208...240 V; 380...500 V; 525...690 V; (-10%...+10%)
	Input frequency	50...60 Hz ($\pm 10\%$)
	Connection to mains	Once per minute or less (normal case)
Motor connection	Output voltage	$0-U_{in}$
	Continuous output current	High overloadability Amps
		Low overloadability Amps
	Overload Capacity	High: 150% Nominal Amps; 1 min, Low: 110% Nominal Amps; 1 min
	Output frequency	0...320 Hz
	Frequency resolution	0.01 Hz
Control characteristics	Control method	Frequency control V/f; Open Loop Vector Control (speed, torque) Closed Loop Control, Permanent Magnet Synchronous Motor Control (NXP Only)
	Switching frequency	208..240V/380..500V: FR4-6: 1...16 kHz; Factory default: 10 kHz FR7-9: 1...10 kHz; Factory default: 3.6 kHz FR10-11: 1...6 kHz; Factory default: 3.6 kHz 525..690V: FR4-11: 1...6 kHz, Factory default: 1.5 kHz
	Field weakening point	8...320 Hz
	Acceleration time	0...3000 sec
	Deceleration time	0...3000 sec
	Braking	DC brake: 30% * T_N (without brake resistor), flux braking
Ambient conditions	Ambient operating temperature	14 F (no frost)...122 F: High OL (FR10-FR11: max 104 F) 14 F (no frost)...104 F: Low OL (NXS 0416 6 and NXS 0590 6: max 95 F)
	Storage temperature	-40F...158 F
	Relative humidity	0 to 95% RH, non-condensing, non-corrosive, no dripping water
	Air quality: - chemical vapours - mechanical particles	IEC 60721-3-3, unit in operation, class 3C2 IEC 60721-3-3, unit in operation, class 3S2
	Altitude	100% load capacity (no derating) up to 3280 feet 1-% derating for each 328 feet above 3280 feet; max. 9840 feet
	Vibration EN50178/EN60068-2-6	5...150 Hz: Displacement amplitude 1 mm (peak) at 5...15.8 Hz (FR10-FR11: 0.25 mm (peak) at 5...31 Hz) Max acceleration amplitude 1 G at 15.8...150 Hz (FR10 and up: 1 G at 31...150 Hz)
	Shock EN50178, EN60068-2-27	UPS Drop Test (for applicable UPS weights) Storage and shipping: max 15 G, 11 ms (in package)
	Enclosure class	UL Type 1/IP21 and UL Type 12/IP54
EMC	Immunity	Fulfil all EMC immunity requirements
	Emissions	EMC level C1: IEC/EN61800-3 (2004), category C1 EMC level C2: IEC/EN61800-3 (2004), category C2 EMC level C3: IEC/EN61800-3 (2004), category C3 EMC level C4: Low earth-current solution suitable for IT networks, IEC/EN61800-3 (2004), category C4
Safety		EN 50178 (1997), EN 60204-1 (2006), IEC 61800-5, CE, UL, CUL; (see unit nameplate for more detailed approvals)
Control connections (OPT-A1, -A2 or OPT-A1, -A3)	Analogue input voltage	0...+10 V (-10 V...+10 V joystick control), $R_i = 200\text{ k}\Omega$, resolution 0.1%, accuracy $\pm 1\%$
	Analogue input current	0(4)...20 mA, $R_i = 250\ \Omega$ differential, resolution 0.1%, accuracy $\pm 1\%$
	Digital inputs	6, positive or negative logic; 18...30 VDC
	Auxiliary voltage	+24 V, $\pm 15\%$, max. 250 mA
	Output reference voltage	+10 V, +3%, max. load 10 mA
	Analogue output	0(4)...20 mA; R_L max. 500 Ω , resolution 10 bit, accuracy $\pm 2\%$
	Digital output	Open collector output, 50 mA/48 V
	Relay outputs	2 programmable change-over (NO/NC) relay outputs (OPT-A3: NO/NC+NO) Switching capacity: 24 VDC/8 A, 250 VAC/8 A, 125 VDC/0.4 A. Min. switching load: 5 V/10 mA
Thermistor input (OPT-A3)	Galvanically isolated, $R_{trip} = 4.7\text{ k}\Omega$	
Protections		Overvoltage, undervoltage, earth fault, mains supervision, motor phase supervision, overcurrent, unit overtemperature, motor overload, motor stall, motor underload, short-circuit of +24 V and +10 V reference voltages

WE ARE DRIVES



VACON[®] NXP & NXC



CONTINUOUS CONTROL. PURE POWER.

VACON NXP is a premium air-cooled AC drive for use in all applications where reliability, robust performance, precision and power are required. These drives are available in the power range from 0.55 kW to 2,000 kW.

IDEAL FOR DEMANDING APPLICATIONS

As a dedicated AC drives company, Vacon continues to pioneer trends in product design and provide innovative solutions for demanding applications and high power ranges. Our NXP range offers the ultimate in motor control, for both induction and permanent magnet (PM) motors, gearless drive applications and paralleling solutions for high power motors.

VACON NXP is the smart drive of choice. With fast fieldbus options and exceptional programming flexibility, your NXP is easily integrated into any plant's automation system. Satisfied customers also rely on our enclosed cabinet drive solution, VACON NXC, to perform in the most challenging industrial environments such as oil & gas, extrusion, mining, pulp & paper and water & wastewater applications.

With improved functional safety, extensive approvals in place and comprehensive maintenance tools, you can be sure that your Vacon AC drives will give you the best possible control and ensure high operational quality and availability over the entire lifetime of your system.

Our VACON NXP portfolio fulfills key international standards and global requirements, including safety and EMC & Harmonics approvals.

IN HARMONY WITH THE ENVIRONMENT

Vacon is also committed to being an environmentally responsible company and our energy saving products and solutions are a good example of that. We have developed our manufacturing process in order to minimize the impact on the environment. All excess materials in the production and service processes are carefully sorted and recycled. Likewise, we continue to develop innovative solutions utilizing, for example, regenerative energy and smart grid technology to help customers effectively monitor and control energy use and costs.

VACON AT YOUR SERVICE

Vacon drives are sold in over 100 countries, with production and R&D on 3 continents, sales offices in 27 countries and service centers in over 50 locations worldwide.

Whether you are an original equipment manufacturer (OEM), system integrator, brand label customer, distributor or end user, Vacon provides services to help you meet your business targets. Our global service solutions are available 24/7 throughout the product lifecycle with the intent to minimize the total cost of ownership and environmental load.

COUNT ON A SMOOTH RIDE

Vacon has partnered with global elevator manufacturers to provide drives solutions for both IM and PM motors used in high, mid and low rise buildings. Vacon drives are appreciated for their exceptionally smooth performance and approval ratings on harmonics, safety, and technology.

VACON®
NXP & NXC



NXP WALL-MOUNTED RANGE



NXP DRIVE MODULES



NXC DRIVE CABINETS

VACON NXP/NXC

WHAT'S IN IT FOR YOU

Typical segments	Key features	Benefits
<ul style="list-style-type: none"> • Mining & minerals • Compressors • Marine & offshore • Cranes & hoists • Metals • Chemical & refining • Water & wastewater • Oil & gas • Pulp & paper • Cement & glass • General process industry 	Full power and voltage range from 0.55 kW to 2.0 MW for both induction and permanent magnet motors.	Same software tools, same control and option boards allowing the maximum utilisation of NXP features over a wide power range.
	Extensive range of ready-to-use applications for basic to demanding needs.	No additional software engineering required, saving time and money.
	Create your own applications with VACON NC61131-3 Engineering tool.	Customized applications provide added flexibility to meet process requirements.
	Five built-in expansion slots for additional I/O, fieldbus and functional safety boards.	No additional external modules required. Options boards are compact and easy to install at any time.

MULTIPLE OPTIONS



VACON NXP CONTROL

VACON NXP offers a high-performance control platform for all demanding drive applications. The micro controller provides both exceptional processing and calculation power. The VACON NXP supports both induction and permanent magnet motors in open and closed loop control modes. The VACON NXP features built-in PLC functionality without the need for any additional hardware. VACON NC61131-3 Engineering can be used to improve performance and create cost savings by integrating customer-specific functionality into the drive. The same control board is used in all NXP drives, allowing the maximum utilization of NXP control features over a wide power and voltage range.



USER-FRIENDLY KEYPAD

Vacon has ensured that the user interface is intuitive to use. You will enjoy the keypad's well-structured menu system that allows for fast commissioning and trouble-free operation.

- Removable panel with plug-in connection
- Graphical and text keypad with multiple language support
- Text display multi-monitoring function
- Parameter backup and copy function with the panel's internal memory
- Vacon's Startup Wizard ensures a hassle-free set up. Choose the language, application type and main parameters during the first power-up.



DC COOLING FANS

VACON NXP high-performance air-cooled products are equipped with DC fans. This significantly increases the reliability and lifetime of the fan also fulfilling the ERP2015 directive on decreasing fan losses. Likewise, the DC-DC supply board component ratings fulfill industrial requirement levels.



CONFORMAL COATING

To increase performance and durability, conformally coated circuit boards (also known as varnished boards) are provided as standard for power modules.

The upgraded boards offer reliable protection against dust and moisture and extend the lifetime of the drive and critical components.

FIELD BUS OPTIONS

Your VACON NXP is easily integrated within a plant's automation system by using plug-in fieldbus option boards including Profibus DP, Modbus RTU, DeviceNet and CANopen. Fieldbus technology ensures increased control and monitoring of the process equipment with reduced cabling - ideal for industries where the need to ensure that products are produced under the right conditions is of paramount importance. An external +24 V supply option enables communication with the control unit even if the main supply is switched off. Fast drive-to-drive communication is possible using Vacon's fast SystemBus fiber optic communication.

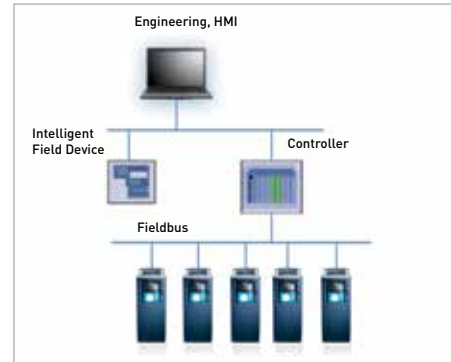

ETHERNET CONNECTIVITY

VACON NXP is the smart drive of choice, as there is no need to purchase additional communication tools. Ethernet connectivity allows remote drive access for monitoring, configuring and troubleshooting. Vacon's Ethernet protocols such as Profinet IO, Ethernet IP and Modbus/TCP are available for all NXP drives. New Ethernet protocols are being continuously developed.



SAFE TORQUE OFF, SAFE STOP 1*

Safe Torque Off (STO) is available for all NXP drives. It prevents the drive from generating torque on the motor shaft and prevents unintentional start-ups. The function also corresponds to an uncontrolled stop in accordance with stop category 0, EN60204-1.

Safe Stop 1 (SS1) initiates the motor deceleration and initiates the STO function after an application specific time delay. The function also corresponds to a controlled stop in accordance with stop category 1, EN 60204-1.

The advantage of the integrated STO and SS1 safety options compared to standard safety technology using electromechanical switchgear is the elimination of separate components and the effort required to wire and service them, while still maintaining the required level of safety at work.

*Requires OPT-AF



ATEX CERTIFIED THERMISTOR INPUT*

Vacon has developed an ATEX approved thermistor input, as an integrated option. Certified and compliant with the European ATEX directive 94/9/EC, the integrated thermistor input is specially designed for the temperature supervision of motors that are placed in areas in which potentially explosive gas, vapor, mist or air mixtures are present and areas with combustible dust. Typical industries requiring such supervision include chemical, petrochemical, marine, metal, mechanical, mining, and oil drilling.

If over-heating is detected, the drive immediately stops feeding energy to the motor. As no external components are needed, the cabling is minimized, improving reliability and saving on both space and costs.

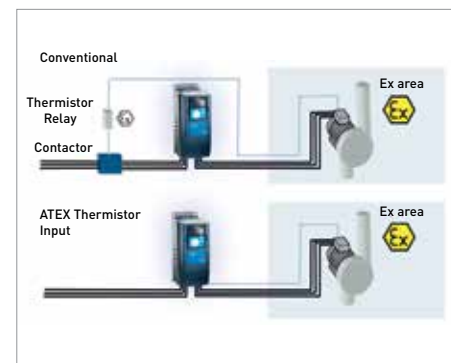

*Requires OPT-AF and IP54/UL Type 12 Enclosure

OPTIONS FOR EVERY APPLICATION



OPTION BOARDS

Our VACON® NXP Control provides exceptional modularity by offering five (A, B, C, D and E) plug-in extension slots. Fieldbus boards, encoder boards as well as wide range of IO boards can simply be plugged-in at any time without the need to remove any other components.

OPTION BOARDS*

Type	Card slot					I/O signal																			Note				
	A	B	C	D	E	DI	DO	DI	AI	AI	AO	AO	RO	RO	+10V _{ref}	Therm	+24V/ EXT +24V	pt100	KTY84	42- 240 VAC input	DI/DO	DI/DO	DI	Re- solver		Out +5V/ +15V/ +24V	Out +15V/ +24V	Out +5V/ +12V/ +15V	
Basic I/O cards (OPT-A)																													
OPT-A1						6	1		2		1				1		2												
OPT-A2													2																
OPT-A3													1	1		1													
OPT-A4						2																	3/0			1			
OPT-A5						2																					1		
OPT-A7																							3/0				1		2 enc. input + 1 enc. output
OPT-A8						6	1		2		1				1		2												1)
OPT-A9						6	1		2		1				1		2												2.5 mm ² terminals
OPT-AE							2																3/0			1			DO = Divider+Direction
OPT-AF ¹							2						1	1		1												EN954-1, cat 3 / ATEX therm.	
OPT-AK																													Sin/Cos/ Marker
OPT-AN						6			2		2														3		1		Limited support
I/O expander cards (OPT-B)																													
OPT-B1							6									1	1												Selectable DI/DO
OPT-B2													1	1		1													2)
OPT-B4									1		2						1												
OPT-B5														3															
OPT-B8																1	3												
OPT-B9																							5						
OPT-BH						2									1														
OPT-BB							2											3	3									1	3 x pt1000; 3 x Ni1000
OPT-BC																													Sin/Cos+ EnDat
OPT-BC																							3/3			1			Encoder out=Resolver simulation
OPT-BE																													EnDat/SSI
Fieldbus cards (OPT-C)																													
OPT-C2																													Modbus RTU, N2
OPT-C3																													
OPT-C4																													
OPT-C5																													
OPT-C6																													
OPT-C7																													
OPT-C8																													Modbus RTU, N2
OPT-CG																													
OPT-CI																													
OPT-CJ																													
OPT-CP																													
OPT-CQ																													
Communication cards (OPT-D)																													
OPT-D1																													
OPT-D2																													
OPT-D3																													
OPT-D6																													
OPT-D7																													

* All Option Boards can be ordered as Varnished boards as well. Simply add -V to the end of the type code. Ex. OPT-CQ-V

¹ OPT-AF requires UL Type 12 (IP54) enclosure for ATEX certification

Vacon DriveSynch is an innovative control concept for running standard drives in parallel to control high-power AC motors or increase the redundancy of a system. This concept suits high power single or multiple winding motors typically above 1 MW.

High power AC drives up to 5 MW can be built using standard drive components and have the following benefits:

- The system is modular and easy to extend
- High total power can be obtained by combining smaller drives
- System redundancy is higher than in a conventional drive because each unit can run independently
- Individual drive is easy to maintain and service
- Identical units reduce the required amount of spare parts thus reducing overall costs
- No special skills are required for the engineering, installation, commissioning and maintenance of high-power drives as they are comprised of standard modules
- It is possible to run multiple winding motors with a phase shift between the windings

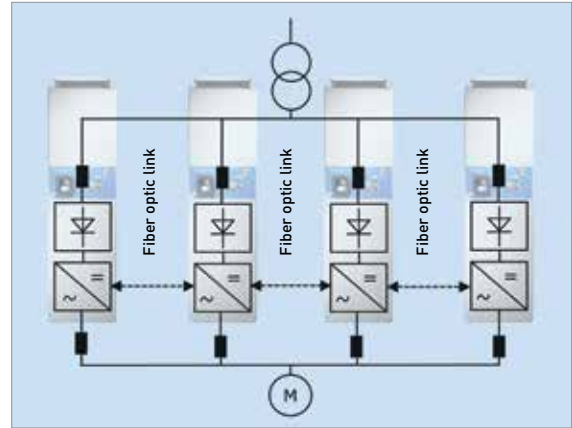

Example of the DriveSynch configuration.

TYPICAL VACON DRIVESYNCH EXAMPLES

VACON NXC 380-500V, 50/60HZ, 3~

AC drive type	Loadability		Motor shaft power		Frame size	Dimensions W x H x D (mm)	Weight (kg)	
	Low (+40°C)	High (+40°C)	400 V supply					
	Rated continuous current I _L (A)	Rated continuous current I _H (A)	10% overload P (kW)	50% overload P (kW)				
2 x NXC 1150	5 A 2 L 0 SSF	2150	1940	1200	1100	2 x FR13	1606 x 2275 x 605	1350
2 x NXC 1300	5 A 2 L 0 SSF	2470	2185	1350	1100			
2 x NXC 1450	5 A 2 L 0 SSF	2755	2470	1500	1350	3 x FR13	1606 x 2275 x 605	1350
3 x NXC 1150	5 A 2 L 0 SSF	3278	2936	1800	1500			
3 x NXC 1300	5 A 2 L 0 SSF	3705	3278	2000	1800			
3 x NXC 1450	5 A 2 L 0 SSF	4133	3705	2250	2000			

Values are given at switching frequency 2.0 kHz.

VACON NXC 380-500V, 50/60HZ, 3~

AC drive type	Loadability		Motor shaft power		Frame size	Dimensions W x H x D (mm)	Weight (kg)	
	Low (+40°C)	High (+40°C)	690 V supply					
	Rated continuous current I _L (A)	Rated continuous current I _H (A)	10% overload P (kW)	50% overload P (kW)				
2 x NXC 0920	6 A 2 L 0 SSF	1748	1500	1710	1520	2 x FR13	1406 x 2275 x 605	1250
2 x NXC 1030	6 A 2 L 0 SSF	1810	1500	1710	1520			
2 x NXC 1180	6 A 2 L 0 SSF*	1950	1630	1900	1610	3 x FR13	1406 x 2275 x 605	1250
3 x NXC 0920	6 A 2 L 0 SSF	2622	2337	2500	2200			
3 x NXC 1030	6 A 2 L 0 SSF	2706	2337	2500	2200			
3 x NXC 1180	6 A 2 L 0 SSF*	2910	2500	2800	2410			

* max. ambient temperature of +35°C.
values are given at switching frequency 2.0 kHz.

VACON NXP WALL-MOUNTED

The VACON NXP Wall-Mounted is one of the most compact and comprehensive drive packages on the market, with all the necessary components integrated in a single frame. For the lower power range, VACON NXP drives are available in a compact IP21/UL Type 1 or IP54/UL Type 12 frame.

FULLY EQUIPPED

VACON NXP wall-mounted units are equipped with internal EMC filtering, and the power electronics are integrated into an all-metal frame. The smaller frame sizes (FR4-FR6) have an integrated brake chopper as standard, and the 380-500 V units can be equipped with an integrated brake resistor. The larger frames (FR7-FR12) can be equipped with an integrated brake chopper as an option.



VACON NXP (FR8)

VACON NXP (FR7)

FEATURES

- Complete voltage range 230...690VAC
- Removable panel with parameter back-up function
- Common control board
- Built-in I/O expandability, 5 slots available and option boards in all frame sizes
- Marine type approvals and functional safety features

BENEFITS

- One type of drive for wide power and voltage range reduces the complexity and the need for additional training
- Easier commissioning – saves time
- Same software tools and applications for the entire range
- Compact and easy to install – saves time and money
- System complexity can be reduced saving engineering time and costs

TYPICAL APPLICATIONS

- Elevators & escalators
- Cranes & hoists
- Winches & cargo pumps
- Pumps & fans
- Conveyors
- Machine tools
- Yaw & pitch control
- Oil pumps
- Winders & unwinders
- Pulp dryers
- Tissue machinery
- Extruders

RATINGS AND DIMENSIONS

Mains Voltage	AC Drive Type		Motor Shaft Power and Current						Frame Size	Dimensions W x H x D (mm) W x H x D (in)	Weight (kg) Weight (lbs)
			High Overload (150%)			Low Overload (110%)					
			Power (HP)	Power (kW)*	I _L [A]	Power (HP)	Power (kW)*	I _L [A]			
208-240 V 50/60 Hz 3~	NXP 0003	2A2H1SSSA1A2	0.5	0.37	2.4	0.75	0.55	3.7	FR4	128.01 x 292.1 x 189.99 5.04 x 11.50 x 7.48	4,989 11
	NXP 0004	2A2H1SSSA1A2	0.75	0.55	3.7	1	0.75	4.8			
	NXP 0007	2A2H1SSSA1A2	1	0.75	4.8	1.5	1.1	6.6			
	NXP 0008	2A2H1SSSA1A2	1.5	1.1	6.6	2	1.5	7.8			
	NXP 0011	2A2H1SSSA1A2	2	1.5	7.8	3	2.2	11			
	NXP 0012	2A2H1SSSA1A2	3	2.2	11	4	3	12.5			
	NXP 0017	2A2H1SSSA1A2	4	3	12.5	5	4	17.5			
	NXP 0025	2A2H1SSSA1A2	5	4	17.5	7.5	5.5	25			
	NXP 0031	2A2H1SSSA1A2	7.5	5.5	25	10	7.5	31			
	NXP 0048	2A2H1SSSA1A2	10	7.5	31	15	11	48	FR6	195.07 x 518.92 x 236.98 7.68 x 20.43 x 9.33	18,597 41
	NXP 0061	2A2H1SSSA1A2	15	11	48	20	15	61	FR7	236.98 x 591.05 x 257.04 9.33 x 23.27 x 10.12	34,926 77
	NXP 0075	2A2H0SSSA1A2	20	15	61	25	18.5	75	FR8	291.08 x 757.93 x 343.91 11.46 x 29.84 x 13.54	58,059 128
	NXP 0088	2A2H0SSSA1A2	25	18.5	75	30	22	88	FR9	480.06 x 1,150.11 x 361.95 18.90 x 45.28 x 14.25	146,056 322
	NXP 0114	2A2H0SSSA1A2	30	22	88	40	30	114			
	NXP 0140	2A2H0SSSA1A2	40	30	105	50	37	140			
	NXP 0170	2A2H0SSSA1A2	50	37	140	60	45	170			
	NXP 0205	2A2H0SSSA1A2	60	45	170	75	55	205			
	NXP 0261	2A2H0SSFA1A2	75	55	205	100	75	261			
NXP 0300	2A2H0SSFA1A2	100	75	245	125	90	300				
380-500 V 50/60 Hz 3~	NXP 0003	5A2H1SSSA1A2	1	0.75	2.2	1.5	1.1	3.3	FR4	128.01 x 292.1 x 189.99 5.04 x 11.50 x 7.48	4,989 11
	NXP 0004	5A2H1SSSA1A2	1.5	1.1	3.3	2	1.5	4.3			
	NXP 0005	5A2H1SSSA1A2	2	1.5	4.3	3	2.2	5.6			
	NXP 0007	5A2H1SSSA1A2	3	2.2	5.6	5	3	7.6			
	NXP 0009	5A2H1SSSA1A2	5	3	7.6	5	4	9			
	NXP 0012	5A2H1SSSA1A2	5	4	9	7.5	5.5	12			
	NXP 0016	5A2H1SSSA1A2	7.5	5.5	12	10	7.5	16			
	NXP 0022	5A2H1SSSA1A2	10	7.5	16	15	11	23			
	NXP 0031	5A2H1SSSA1A2	15	11	23	20	15	31			
	NXP 0038	5A2H1SSSA1A2	20	15	31	25	18.5	38	FR6	195.07 x 518.92 x 236.98 7.68 x 20.43 x 9.33	18,597 41
	NXP 0045	5A2H1SSSA1A2	25	18.5	38	30	22	46	FR7	236.98 x 591.05 x 257.04 9.33 x 23.27 x 10.12	34,926 77
	NXP 0061	5A2H1SSSA1A2	30	22	46	40	30	61	FR8	291.08 x 757.93 x 343.91 11.46 x 29.84 x 13.54	58,059 128
	NXP 0072	5A2H0SSSA1A2	40	30	61	50	37	72	FR9	480.06 x 1,150.11 x 361.95 18.90 x 45.28 x 14.25	146,056 322
	NXP 0087	5A2H0SSSA1A2	50	37	72	60	45	87			
	NXP 0105	5A2H0SSSA1A2	60	45	87	75	55	105			
	NXP 0140	5A2H0SSSA1A2	75	55	105	100	75	140			
	NXP 0168	5A2H0SSSA1A2	100	75	140	125	90	170			
	NXP 0205	5A2H0SSSA1A2	125	90	170	150	110	205			
NXP 0261	5A2H0SSFA1A2	150	110	205	200	132	261				
NXP 0300	5A2H0SSFA1A2	200	132	245	200	160	300				
525-690 V 50/60 Hz 3~	NXP 0004	6A2L0SSSA1A2	2	1.5	3.2	3	2.2	4.5	FR6	195.07 x 518.92 x 236.98 7.68 x 20.43 x 9.33	18,597 41
	NXP 0005	6A2L0SSSA1A2	3	2.2	4.5	-	3	5.5			
	NXP 0007	6A2L0SSSA1A2	-	3	5.5	5	4	7.5			
	NXP 0010	6A2L0SSSA1A2	5	4	7.5	7.5	5.5	10			
	NXP 0013	6A2L0SSSA1A2	7.5	5.5	10	10	7.5	13.5			
	NXP 0018	6A2L0SSSA1A2	10	7.5	13.5	15	11	18			
	NXP 0022	6A2L0SSSA1A2	15	11	18	20	15	22			
	NXP 0027	6A2L0SSSA1A2	20	15	22	25	18.5	27			
	NXP 0034	6A2L0SSSA1A2	25	18.5	27	30	22	34			
	NXP 0041	6A2L0SSSA1A2	30	22	34	40	30	41	FR7	236.98 x 591.05 x 257.04 9.33 x 23.27 x 10.12	34,926 77
	NXP 0052	6A2L0SSSA1A2	40	30	41	50	37	52	FR8	291.08 x 757.93 x 343.91 11.46 x 29.84 x 13.54	58,059 128
	NXP 0062	6A2L0SSSA1A2	50	37	52	60	45	62			
	NXP 0080	6A2L0SSSA1A2	60	45	62	75	55	80			
	NXP 0100	6A2L0SSSA1A2	75	55	80	100	75	100			
	NXP 0125	6A2L0SSFA1A2	100	75	100	125	90	125			
	NXP 0144	6A2L0SSFA1A2	125	90	125	150	110	144			
	NXP 0170	6A2L0SSFA1A2	150	110	144	-	132	170			
	NXP 0208	6A2L0SSFA1A2	-	132	170	200	160	208			

* Power ratings in kW for 525-690V NXP are at 575V. Contact your local Vacon Sales Representative for 690V ratings.



VACON NXP STANDALONE

Premium VACON NXP drives are also available in standalone IP21 or IP54 enclosures. These units are delivered in a compact enclosure, making them perfect for areas with limited space, while still providing full NXP control flexibility.

ROBUST AND RELIABLE

VACON NXP standalone drives are fully enclosed at the factory and ready for immediate installation. The drive is ideal for pumps, fans and other single drive applications. The drive has integrated fuses as standard and no extra protection components are required. It is also possible to equip the drive with an optional integrated load switch, which further simplifies handling in the field.

FEATURES

- Extremely compact cabinet enclosure
- Delivered with ultra rapid AC-fuses
- Optional built-in brake chopper and DC-link connectors

BENEFITS

- Maximize the utilization of available space while reducing the overall costs
- No need to consider any additional protection components



HARDWARE CONFIGURATIONS

Function	Availability
IP21	Standard
IP54 (FR10 only)	Optional
Integrated ultra rapid fuses	Standard
Load switch (IEC or UL version)	Optional
EMC filtering L (EN 61800-3, category C3)	Standard
EMC filtering T (for IT -networks)	Optional
Brake chopper (cabling top entry)	Optional (H: +122 mm)

RATINGS AND DIMENSIONS

VACON NXP 380-500 V 50/60 HZ 3[~]

AC Drive Type			Motor Shaft Power and Current					Frame Size	Dimensions W x H x D (mm)	Weight (kg)	
			High Overload (150%)			Low Overload (110%)					
			Power (HP)	Power (kW)	I _H (A)	Power (HP)	Power (kW)				I _L (A)
NXP 0385	5A2L0SSA	200	160	300	300	200	385	FR10	595 x 2020 x 602	340	
NXP 0460	5A2L0SSA	300	200	385	350	250	460				
NXP 0520	5A2L0SSA	350	250	460	450	250	520				
NXP 0590	5A2L0SSA	450	250	520	500	315	590	FR11	794 x 2020 x 602	470	
NXP 0650	5A2L0SSA	500	315	590	550	355	650				
NXP 0730	5A2L0SSA	550	355	650	600	400	730				

VACON NXP 525-690 V 50/60 HZ 3[~]

AC Drive Type			Motor Shaft Power and Current					Frame Size	Dimensions W x H x D (mm)	Weight (kg)	
			High Overload (150%)			Low Overload (110%)					
			Power (HP)	Power (kW)	I _H (A)	Power (HP)	Power (kW)				I _L (A)
NXP 0261	6A2L0SSA	200	200	208	250	250	261	FR10	595 x 2020 x 602	340	
NXP 0325	6A2L0SSA	250	250	261	300	315	325				
NXP 0385	6A2L0SSA	300	315	325	400	355	385				
NXP 0416	6A2L0SSA*	400	355	385	450	400	416	FR11	794 x 2020 x 602	400	
NXP 0460	6A2L0SSA	450	400	416	*	450	460		794 x 2020 x 602	400	
NXP 0502	6A2L0SSA	*	450	460	500	500	502		794 x 2020 x 602	470	
NXP 0590	6A2L0SSA*	500	500	502	550	560	590				

* max. ambient temperature of +35°C

TYPICAL APPLICATIONS

- Auxiliary equipment
- Pump & fans
- Main propulsion & bow thrusters
- Compressors
- Cranes & lifts



VACON NXP DRIVE MODULE

VACON NXP high-power IP00 drive modules are intended for installation into a cabinet, switchgear or any separate enclosure. Module installation in standard enclosures is easy given the compact design.

DESIGNED TO FIT

VACON NXP drive modules of frame size FR10 - FR12 embody one (FR10 and FR11) or two (FR12) power modules. NXP frame sizes FR13 - FR14 comprise two to four non-regenerative front-end (NFE) units and one (FR13) or two (FR14) inverter units. External AC-chokes are also included in the delivery. The NXP modules are available as both 6-pulse and 12-pulse supply versions.

FEATURES

- Easy cabinet integration with additional assembly kits
- One of the smallest on the market
- Extensive marine type approvals
- DriveSynch features for high power or/and redundancy

BENEFITS

- With optimized module design, less engineering is needed saving time and money
- Compact module size require less cabinet space, while reducing the overall costs
- Improved redundancy and higher powers up to 5.0 MW



HARDWARE CONFIGURATIONS

Function	Availability
Integrated control	Standard
External control	Optional
Integrated brake chopper	Optional (FR 10-12)
6-Pulse Supply	Standard
12-Pulse Supply	Optional
EMC filtering N	Standard
EMC filtering T (for IT -networks)	Optional

RATINGS AND DIMENSIONS

VACON NXP 380-500 V 50/60 HZ 3~

AC drive type			Output Power and Current				Frame size	Dimensions W x H x D (mm)	Weight (kg)
			High Overload (150%)		Low Overload (110%)				
			50% overload P (kW)	Rated continuous current I _H (A)	10% overload P (kW)	Rated continuous current I _L (A)			
NXP 0385	5A0N0SSA-A1A2	160	300	200	385	FR10	500 x 1165 x 506	120	
NXP 0460	5A0N0SSA-A1A2	200	385	250	460				
NXP 0520	5A0N0SSA-A1A2	250	460	250	520				
NXP 0590	5A0N0SSA-A1A2	250	520	315	590				
NXP 0650	5A0N0SSA-A1A2	315	590	355	650	FR11	709 x 1206 x 506	210	
NXP 0730	5A0N0SSA-A1A2	355	650	400	730				
NXP 0820	5A0N0SSA-A1A2	400	730	450	820				
NXP 0920	5A0N0SSA-A1A2	450	820	500	920	FR12	2x (500x1165x506)	2x 210	
NXP 1030	5A0N0SSA-A1A2	500	920	560	1030				
NXP 1150	5A0N0SSF-A1A2	560	1030	630	1150	FR13	2x (239x1030x372)+ 1x (708x1030x553)	2x 67+ 1x 302	
NXP 1300	5A0N0SSF-A1A2	630	1150	710	1300				
NXP 1450	5A0N0SSF-A1A2	710	1300	800	1450				
NXP 1770	5A0N0SSF-A1A2	900	1600	1000	1770				
NXP 2150	5A0N0SSF-A1A2	1100	1940	1200	2150	FR14	4x(239x1030x372)+ 2x(708x1032x553)	4x 67+ 2x 302	

VACON NXP 525-690 V 50/60 HZ 3~

AC drive type			Output Power and Current				Frame size	Dimensions W x H x D (mm)	Weight (kg)
			High Overload (150%)		Low Overload (110%)				
			50% overload P (kW)	Rated continuous current I _H (A)	10% overload P (kW)	Rated continuous current I _L (A)			
NXP 0261	6A0N0SSA-A1A2	200	208	250	261	FR10	500 x 1165 x 506	120	
NXP 0325	6A0N0SSA-A1A2	250	261	315	325				
NXP 0385	6A0N0SSA-A1A2	315	325	355	385				
NXP 0416	6A0N0SSA-A1A2*	315	325	400	416				
NXP 0460	6A0N0SSA-A1A2	355	385	450	460	FR11	709 x 1206 x 506	210	
NXP 0502	6A0N0SSA-A1A2	450	460	500	502				
NXP 0590	6A0N0SSA-A1A2*	500	502	560	590				
NXP 0650	6A0N0SSA-A1A2	560	590	630	650	FR12	2x(500x1165x506)	2x(120)	
NXP 0750	6A0N0SSA-A1A2	630	650	710	750				
NXP 0820	6A0N0SSA-A1A2*	630	650	800	820				
NXP 0920	6A0N0SSF-A1A2	800	820	900	920				
NXP 1030	6A0N0SSF-A1A2	900	920	1000	1030	FR13	2x(239x1030x372)+ 1x(708x1030x553)	2x(67)+ 1x(302)	
NXP 1180	6A0N0SSF-A1A2*	1000	1030	1150	1180				
NXP 1500	6A0N0SSF-A1A2	1300	1300	1500	1500	FR14	3x(239x1030x372)+ 2x(708x103x553) [§]	3x(67)+ 2x(302) [§]	
NXP 1900	6A0N0SSF-A1A2	1500	1500	1800	1900				
NXP 2250	6A0N0SSF-A1A2*	1800	1900	2000	2250				

* max. ambient temperature of +35°C. See "VACON NXP IP00 Modules Installation Manual" for 12-pulse configurations and AC choke dimensions.

TYPICAL APPLICATIONS

- Conveyors
- Cranes & lifts
- High-speed compressors
- Ski lifts
- Main propulsion & bow thrusters
- Extruders
- Winches & cargo pumps
- Oil pumps
- Test benches
- Static power supply
- Grinders & mixers
- Winders & unwinders
- Chippers
- Tunneling Machines



VACON®
NXP & NXC

VACON NXC

Our VACON NXC is designed to meet the most demanding requirements for flexibility, robustness, compactness and service-friendliness. It is a safe choice for any application and available in the 160 to 2000 kW power range and 380-500 V, 500-690 V voltage range.

EXCEPTIONAL PERFORMANCE

Our enclosed VACON NXC variable speed AC drives are compact and well tested to meet harsh operating conditions. They are typically put to work in segments, such as mining, oil & gas, water & wastewater. The reliable thermal handling of the enclosure guarantees extended lifetime of the frequency converter and trouble-free operation in tough environments. Approved EMC solutions ensure reliable operation of the converter without disturbing other electrical equipment.

USER-FRIENDLY

VACON NXC features an easily accessible control compartment for relays, auxiliary terminals and

other equipment and ample space around the power terminals allows for easy installation and connection of power cables. Our trademark handy keypad is located on the door with additional door options including indicators, meters and switches. Bottom plates and earthing claps for 360 degree earthing of motor cables are provided as standard.

SERVICE-FRIENDLY

VACON NXC enclosures are easy to install with lifting lugs for easy handling and can be wall-mounted or free-standing. VACON NXP power units are rail-mounted for easy pull-out, and the optional pull-out jig enables hassle-free servicing of the power unit. No additional cooling fans are required in the enclosure IP21/IP54 and the fans can be easily replaced without having to remove the power unit.



VACON NXC (FR10)

FEATURES

- Robust and type-tested design
- Wide range of standard options
- One of the most compact on the market
- Welded Rittal TS8 frame
- EMC approved (EN61800-3, 2nd env.)
- Service concept with pullout jig
- No additional fans in IP54 enclosure

BENEFITS

- Trouble free installation and operation
- Adapts to your needs w/o engineering
- Easy to fit into small spaces
- Global enclosure availability, easy to extend
- Fast service, easy maintenance

RATINGS & DIMENSIONS

VACON NXC, 6-PULSE SUPPLY

Mains Voltage	AC drive type		Output Power and Current				Frame size	Dimensions W x H x D (mm)	Weight (kg)
			High Overload (150%)		Low Overload (110%)				
			50% overload P (kW)	Rated continuous current I _H (A)	10% overload P (kW)	Rated continuous current I _L (A)			
380-500 V 50/60 Hz 3~	NXC 0261	5 A 2 H 0 SSF	110	205	132	261	FR9	606 x 2275 x 605	371
	NXC 0300	5 A 2 H 0 SSF	132	245	160	300			
	NXC 0385	5 A 2 L 0 SSF	160	300	200	385	FR10	606 x 2275 x 605	403
	NXC 0460	5 A 2 L 0 SSF	200	385	250	460			
	NXC 0520	5 A 2 L 0 SSF	250	460	250	520	FR11	806 x 2275 x 605	577
	NXC 0590	5 A 2 L 0 SSF	250	520	315	590			
	NXC 0650	5 A 2 L 0 SSF	315	590	355	650	FR12	1206 x 2275 x 605	810
	NXC 0730	5 A 2 L 0 SSF	355	650	400	730			
	NXC 0820	5 A 2 L 0 SSF	400	730	450	820	FR13	1406 x 2275 x 605	1000
	NXC 0920	5 A 2 L 0 SSF	450	820	500	920			
	NXC 1030	5 A 2 L 0 SSF	500	920	560	1030	FR14	2806 x 2275 x 605	2440
	NXC 1150	5 A 2 L 0 SSF	560	1030	630	1150			
	NXC 1300	5 A 2 L 0 SSF	630	1150	710	1300	FR13	1406 x 2275 x 605	1150
	NXC 1450	5 A 2 L 0 SSF	710	1300	800	1450			
NXC 1770	5 A 2 L 0 SSF	900	1600	1000	1770	FR14	2806 x 2275 x 605	2440	
NXC 2150	5 A 2 L 0 SSF	1100	1940	1200	2150				
525-690 V 50/60 Hz 3~	NXC 0125	6 A 2 L 0 SSF	90	100	110	125	FR9	606 x 2275 x 605	371
	NXC 0144	6 A 2 L 0 SSF	110	125	132	144			
	NXC 0170	6 A 2 L 0 SSF	132	144	160	170	FR10	606 x 2275 x 605	371
	NXC 0208	6 A 2 L 0 SSF	160	170	200	208			
	NXC 0261	6 A 2 L 0 SSF	200	208	250	261	FR11	806 x 2275 x 605	524 577
	NXC 0325	6 A 2 L 0 SSF	250	261	315	325			
	NXC 0385	6 A 2 L 0 SSF	315	325	355	385	FR12	1206 x 2275 x 605	745
	NXC 0416	6 A 2 L 0 SSF*	315	325	400	416			
	NXC 0460	6 A 2 L 0 SSF	355	385	450	460	FR13	1406 x 2275 x 605	1000
	NXC 0502	6 A 2 L 0 SSF	450	460	500	502			
	NXC 0590	6 A 2 L 0 SSF*	500	502	560	590	FR14	2406 x 2275 x 605	2350
	NXC 0650	6 A 2 L 0 SSF	560	590	630	650			
	NXC 0750	6 A 2 L 0 SSF	630	650	710	750	FR12	1206 x 2275 x 605	745
	NXC 0820	6 A 2 L 0 SSF*	630	650	800	820			
	NXC 0920	6 A 2 L 0 SSF	800	820	900	920	FR13	1406 x 2275 x 605	1000
	NXC 1030	6 A 2 L 0 SSF	900	920	1000	1030			
	NXC 1180	6 A 2 L 0 SSF*	1000	1030	1150	1180	FR14	2806 x 2275 x 605	2440
	NXC 1500	6 A 2 L 0 SSF	1300	1300	1500	1500			
	NXC 1900	6 A 2 L 0 SSF	1500	1500	1800	1900	FR14	2806 x 2275 x 605	2500
	NXC 2250	6 A 2 L 0 SSF*	1800	1900	2000	2250			

* max. ambient temperature of +35°C

HARDWARE CONFIGURATIONS, 6-PULSE SUPPLY

6-pulse	Enclosure		EMC			Brake chopper	Cabling		Input device					Output filters			
	IP21	IP54	L	T	H		Bottom	Top +CIT/+COT	+IFU	+ILS	+IFD	+ICO	+ICB	+OCM/ +OCH	+ODU	+OSI	
380-500 V	FR9	S	O (H: +130)	S	O	-	0	S	O (W: +400)	0	0	0	0	0	0	0	0 (W: +600)
	FR10	S	O (H: +130)	S	O	-	0	S	O (W: +400)	0	0	0	0	0	0	0	0 (W: +600)
	FR11	S	O (H: +130)*	S	O	-	0	S	O (W: +400)	0	0	0	0	0	0	0	0 (W: +600-800)
	FR12	S	O (H: +130)	S	O	-	0	S	O (W: +400)	0	0	0	0	0	0	0	0 (W: +400)
	FR13	S	O (H: +170)	S	O	-	1	S	O (W: +400)	-	-	S	-	0	0	0	0 (W: +800)
	FR14	S	O (H: +170)	S	O	-	1	S	O (W: +600)	-	-	-	-	S	0	S	0 (W: +1600)
525-690 V	FR9	S	O (H: +130)	S	O	-	0	S	O (W: +400)	0	0	0	0	0	0	0	0 (W: +600)
	FR10	S	O (H: +130)	S	O	-	0	S	O (W: +400)	0	0	0	0	0	0	0	0 (W: +600)
	FR11	S	O (H: +130)*	S	O	-	0	S	O (W: +400)	0	0	0	0	0	0	0	0 (W: +600-800)
	FR12	S	O (H: +130)	S	O	-	0	S	O (W: +400)	0	0	0	0	0	0	0	0 (W: +400)
	FR13	S	O (H: +170)	S	O	-	1	S	O (W: +400)	-	-	S	-	0	0	0	0 (W: +800)
	FR14	S	O (H: +170)	S	O	-	1	S	O (W: +600)	-	-	-	-	S	0	S	0 (W: +1600)

S = Standard O = Optional 1 (W: +400) = Contact factory

* NXC07305 and NXC05906, H: +170 mm



VACON NXC LOW-HARMONIC

The VACON NXC low-harmonic drive is the perfect choice for applications where low-harmonics are required. This drive not only meets the most demanding requirements for clean power but also provides other important benefits such as regenerative braking and voltage boost for maximum output power.

CLEAN POWER SAVES MONEY

The low-harmonic cabinet drive offers an excellent total solution to meet even the most demanding power quality requirements. The drive also complies with the IEEE-519, G5/4 harmonic standards.

The low THDi reduces supply currents and allows supply transformers, protection devices and power cables to be dimensioned according to the actual active power. It creates savings for both new and retrofit projects as there's no need to invest in expensive 12- or 18-pulse transformers.

FEATURES

- Clean power with total current harmonics THDi < 5 %
- Over-dimensioning of power transformer or input cables is not required
- Regenerative function available
- Reducing system complexity
- No need for special 12-pulse transformers
- Well-suited for retrofit projects
- Increased flexibility with a wide range of standard options

BENEFITS

- Over-dimensioning of input components is not needed, reducing the total costs
- Voltage boost function for maximum output power
- Braking energy can be fed back to network saving energy costs
- Reduces overall investment costs and optimizes the use of available space



TYPICAL APPLICATIONS

- Pumps & fans
- Water treatment
- Thrusters & main propulsion
- Crushers & conveyors & mills
- Industrial elevators
- Test benches
- Sugar refineries

RATINGS AND DIMENSIONS

Mains Voltage	Low-harmonic drive type		Output Power and Current				Frame size	Dimensions W x H x D (mm)	Weight (kg)
			High Overload (150%)		Low Overload (110%)				
			50% overload P (kW)	Rated continuous current I H (A)	10% overload P (kW)	Rated continuous current I L (A)			
380-500 V 50/60 Hz	NXC 0261	5A2L0RSF	110	205	132	261	AF9	1006 x 2275 x 605	680
	NXC 0300	5A2L0RSF	132	245	160	300			
	NXC 0385	5A2L0RSF	160	300	200	385			
	NXC 0460	5A2L0RSF	200	385	250	460	AF10	1006 x 2275 x 605	700
	NXC 0520	5A2L0RSF	250	460	250	520			
	NXC 0650	5A2L0RSF	315	590	355	650	AF12	2006 x 2275 x 605	1400
	NXC 0730	5A2L0RSF	355	650	400	730			
	NXC 0820	5A2L0RSF	400	730	450	820	AF12	2006 x 2275 x 605	1400
	NXC 0920	5A2L0RSF	450	820	500	920			
	NXC 1030	5A2L0RSF	500	920	560	1030			
	NXC 1150	5A2L0RSF	560	1030	630	1150	AF13	2206 x 2275 x 605	1950
	NXC 1300	5A2L0RSF	630	1150	710	1300			
	NXC 1450	5A2L0RSF	710	1300	800	1450	AF14	4406 x 2275 x 605	3900
	NXC 1770	5A2L0RSF	900	1600	1000	1770			
NXC 2150	5A2L0RSF	1100	1940	1200	2150				
NXC 2700	5A2L0RSF	1200	2300	1500	2700				
525-690 V 50/60 Hz	NXC 0125	6A2L0RSF	90	100	110	125	AF9	1006 x 2275 x 605	680
	NXC 0144	6A2L0RSF	110	125	132	144			
	NXC 0170	6A2L0RSF*	132	144	160	170			
	NXC 0208	6A2L0RSF	160	170	200	208	AF10	1006 x 2275 x 605	700
	NXC 0261	6A2L0RSF	200	208	250	261			
	NXC 0325	6A2L0RSF	250	261	315	325			
	NXC 0385	6A2L0RSF	315	325	355	385	AF12	2006 x 2275 x 605	1400
	NXC 0416	6A2L0RSF*	315	325	400	416			
	NXC 0460	6A2L0RSF	355	385	450	460	AF12	2006 x 2275 x 605	1400
	NXC 0502	6A2L0RSF	450	460	500	502			
	NXC 0590	6A2L0RSF	500	502	560	590			
	NXC 0650	6A2L0RSF	560	590	630	650	AF13	2206 x 2275 x 605	1950
	NXC 0750	6A2L0RSF	630	650	710	750			
	NXC 0820	6A2L0RSF*	650	650	750	820	AF13	2206 x 2275 x 605	1950
	NXC 0920	6A2L0RSF	800	820	900	920			
	NXC 1030	6A2L0RSF	900	920	1000	1030			
	NXC 1180	6A2L0RSF*	1000	1030	1150	1180	AF14	4406 x 2275 x 605	3900
	NXC 1500	6A2L0RSF	1300	1300	1500	1500			
NXC 1900	6A2L0RSF	1500	1500	1800	1900				
NXC 2250	6A2L0RSF*	1800	1900	2000	2250				

* max. ambient temperature of +35 °C

HARDWARE CONFIGURATIONS

Active front-end 380-500 V	Enclosure		EMC		Brake chopper	Cabling		Input device		Output filters	
	IP21	IP54	L	T		Bottom	Top +CIT/+COT	+ILS & +ICB	+OCM/ +OCH	+ODU	+OSI
AF9	S	O (H: +130)	S	O	* (W: +400)	S	O (W: +400)	S	O	O (W: +400)	O (W: +600)
AF10	S	O (H: +130)	S	O	* (W: +400)	S	O (W: +400)	S	O	O (W: +400)	O (W: +600)
AF12	S	O (H: +130)	S	O	* (W: +400)	S	O (W: +400)	S	O	O (W: +400)	O (W: +1200)
AF13	S	O (H: +170)	S	O	* (W: +400)	S	O (W: +400)	S	O	O	O (W: +800)
AF14	S	O (H: +170)	S	O	* (W: +400)	S	O (W: +600)	S	O	S	O (W: +1600)
525-690 V											
AF9	S	O (H: +130)	S	O	* (W: +400)	S	O (W: +400)	S	O	O (W: +400)	O (W: +600)
AF10	S	O (H: +130)	S	O	* (W: +400)	S	O (W: +400)	S	O	O (W: +400)	O (W: +600)
AF12	S	O (H: +130)	S	O	* (W: +400)	S	O (W: +400)	S	O	O (W: +400)	O (W: +1200)
AF13	S	O (H: +170)	S	O	* z(W: +400)	S	O (W: +400)	S	O	O	O (W: +800)
AF14	S	O (H: +170)	S	O	* (W: +400)	S	O (W: +600)	S	O	S	O (W: +1600)

* Contact factory S = Standard O = Optional

VACON NXC OPTIONS

Control terminal options (T group)	
+TIO*	Basic I/O wired to external single-tier terminals
+TID*	Basic I/O wired to external two-tier terminals+additional terminals
+TUP*	Terminals for 230 VAC control voltage
Input device options (I group)	
+ILS*	Load switch
+IFD	Switch fuse and fuses
+ICB*	Circuit breaker
+ICO	Input contactor
+IFU	Input fuses
Main circuit options (M group)	
+MDC	Terminals in cabinet for DC / brake chopper
Output filter options (O group)	
+OCM	Common mode filters
+OCH	Common mode filters with output terminals
+ODU	du/dt filter
+OSI	Sine wave filter
Protection devices (P group)	
+PTR	External thermistor relay
+PES	Emergency stop (cat 0)
+PED	Emergency stop (cat 1)
+PAP	Arc protection
+PIF	Insulation fault sensor
General options	
+G40	400 mm empty cabinet
+G60	600 mm empty cabinet
+G80	800 mm empty cabinet
+GPL	100 mm base
+GPH	200 mm base
+FAT	Factory acceptance tests
+MAR	Marine construction
+SWP	Seaworthy packing

Cabling options (C group)	
+CIT	Input (mains) cabling from top
+COT	Output (motor) cabling from top
Auxiliary equipment (A group)	
+AMF	Motor fan control
+AMH	Motor heater feeder
+AMB	Mechanical brake control
+AMO*	Motor operator for +ICB
+ACH	Cabinet heater
+ACL	Cabinet light
+ACR	Control relay
+AAI	Analogue signal isolator
+AAA	Auxiliary contact (control voltage devices)
+AAC	Auxiliary contact (input device)
+AT1	Auxiliary voltage transformer 200 VA
+AT2*	Auxiliary voltage transformer 750 VA
+AT3	Auxiliary voltage transformer 2500 VA
+AT4	Auxiliary voltage transformer 4000 VA
+ADC*	Power supply 24 VDC 2.5 A
+ACS	230 VAC customer socket
Door-mounted options (D group)	
+DLV	Pilot light (Control voltage on)
+DLD	Pilot light (DO1)
+DLF	Pilot light (FLT)
+DLR	Pilot light (RUN)
+DCO*	Main contactor operation switch
+DRO*	Local / Remote operation switch
+DEP	Emergency stop push-button
+DRP	Reset push-button
+DAM	Analogue meter (A01)
+DAR	Potentiometer for reference
+DCM	Analogue meter & current transformer
+DVM	Analogue voltage meter with selection switch

* Included as standard in low-harmonic drives



THE VACON NXP/NXC PRODUCT RANGE

Mains connection	Input voltage U_{in}	208...240 V; 380...500 V; 525...690 V; -10%...+10% NXC low-harmonic drive 525-690 V; -10%...+10%
	Input frequency	45...66 Hz
	Connection to mains	Once per minute or less (normal case)
Motor connection	Output voltage	$0-U_{in}$
	Continuous output current	High overloadability: I_H , ambient temperature max. +50°C ($\geq FR10 + 40^\circ C$) Low overloadability: I_L , ambient temperature max. +40°C
	Overloadability	High: $1.5 \times I_H$ (1 min/10 min), Low: $1.1 \times I_L$ (1 min/10 min)
	Max. starting current	I_S for 2 s every 20 s
	Output frequency	$0...320$ Hz
Control characteristics	Control performance	Open loop vector control (5-150% of base speed): speed control 0.5%, dynamic 0.3%sec, torque lin. <2%, torque rise time ~5 ms Closed loop vector control (entire speed range): speed control 0.01%, dynamic 0.2% sec, torque lin. <2%, torque rise time ~2 ms
	Switching frequency	NX_2/ Up to and including NX_0061: NX_5: 1...16 kHz; Factory default 10 kHz From NX_0072: 1...6 kHz; Factory default 3.6 kHz NX_6: 1...6 kHz; Factory default 1.5 kHz
	Field weakening point	$8...320$ Hz
	Acceleration time	$0...3000$ sec
	Deceleration time	$0...3000$ sec
	Braking	DC brake: 30% of T_N (without brake resistor), flux braking
Ambient conditions	Ambient operating temperature	-10°C (no frost)...+50°C: I_H ($\geq FR10 + 40^\circ C$) -10°C (no frost)...+40°C: I_L
	Storage temperature	-40°C...+70°C
	Relative humidity	0 to 95% RH, non-condensing, non-corrosive, no dripping water
	Air quality: - chemical vapours - mechanical particles	IEC 60721-3-3, unit in operation, class 3C3 (tested in accordance with IEC60068-2-60, Method I C CH ₂ and SO ₂) IEC 60721-3-3, unit in operation, class 3S2
	Altitude	100% load capacity (no derating) up to 1000 m 1% derating for each 100 m above 1000 m; max. 4866 m (690 V max. 2000 m)
	Vibration EN 50178/EN 60068-2-6	5...150 Hz: Displacement amplitude 1 mm (peak) at 5...15.8 Hz ($\geq FR10$: 0.25 mm (peak) at 5...31 Hz) Max acceleration amplitude 1 G at 15.8...150 Hz ($\geq FR10$: 1 G at 31...150 Hz)
	Shock EN 50178, EN 60068-2-27	UPS Drop Test (for applicable UPS weights) Storage and shipping: max 15 G, 11 ms (in package)
EMC	Immunity	Fulfils all EMC immunity requirements
	Emissions	EMC level C: EN 61800-3, category C1 EMC level H: EN 61800-3, category C2 EMC level L: EN 61800-3, category C3 EMC level T: Low earth-current solution is suitable for IT networks, (can be modified from L/H-level units)
Safety		EN 50178, EN 60204-1, IEC 61800-5-1, CE, UL, CUL; (see unit nameplate for more details)
Functional safety *	STO	EN/IEC 61800-5-2 Safe Torque Off (STO) SIL2, EN ISO 13849-1 PL"d" Category 3, EN 62061: SILCL2, IEC 61508: SIL2.
	SS1	EN /IEC 61800-5-2 Safe Stop 1 (SS1) SIL2, EN ISO 13849-1 PL"d" Category 3, EN /IEC62061: SILCL2, IEC 61508: SIL2.
	ATEX Thermistor input	94/9/EC, CE 0537 Ex 11 [2] GD
Control connections (OPT-A1, -A2 or OPT-A1, -A3)	Analogue input voltage	$0...+10$ V (-10 V...+10 V joystick control), $R_i = 200$ k Ω , resolution 0.1%, accuracy $\pm 1\%$
	Analogue input current	$0(4)...20$ mA, $R_i = 250$ Ω differential, resolution 0.1%, accuracy $\pm 1\%$
	Digital inputs	6, positive or negative logic; 18...30 VDC
	Auxiliary voltage	+24 V, $\pm 15\%$, max. 250 mA
	Output reference voltage	+10 V, +3%, max. load 10 mA
	Analogue output	$0(4)...20$ mA; R_L max. 500 Ω , resolution 10 bit, accuracy $\pm 2\%$
	Digital output	Open collector output, 50 mA/48 V
	Relay outputs	2 programmable change-over (NO/NC) relay outputs (OPT-A3: NO/NC+NO) Switching capacity: 24 VDC/8 A, 250 VAC/8 A, 125 VDC/0.4 A. Min. switching load: 5 V/10 mA
Thermistor input (OPT-A3)	Galvanically isolated, $R_{trip} = 4.7$ k Ω	
Protections		Overvoltage, undervoltage, earth fault, mains supervision, motor phase supervision, overcurrent, unit overtemperature, motor overload, motor stall, motor underload, short-circuit of +24 V and +10 V reference voltages

* with OPT-AF board

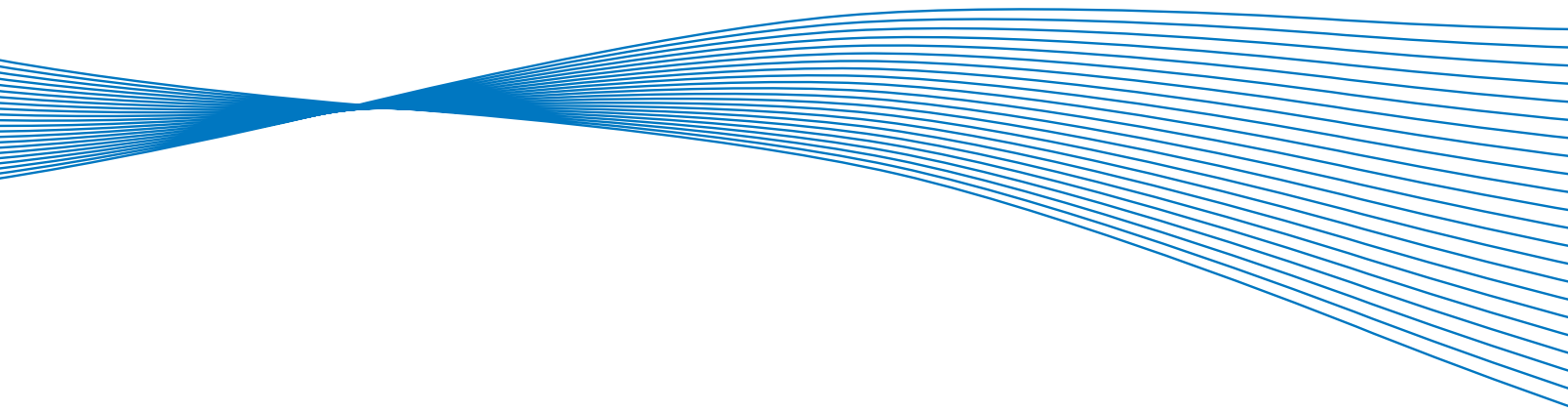

WE ARE DRIVES



**VACON[®] NXP COMMON DC
BUS PRODUCTS**



MODULAR DRIVE SOLUTIONS

Vacon offers a comprehensive range of Common DC bus drive products comprising front-end units, inverter units and brake chopper units in the entire power range and voltages from 380 V to 690 V . The drive components are built on proven VACON NX technology and provide the ideal energy sharing solution for a multitude of power systems.

RELIABLE. ROBUST. PROVEN.

When your goal is to ensure that all AC drives share energy within your industrial system, and that all energy is effectively utilized and redistributed, then VACON Common DC bus drive solutions are the right choice. Our Common DC bus components are used in a multitude of combinations across a wide spectrum of high-power process industries from the pulp & paper, steel, metal & mining and marine cranes to smaller machines and production lines, which also demand cost-effective solutions.

DC bus systems comprise two main categories: regenerative and non-regenerative. In a regenerative DC bus system the front-end unit is capable of generating power back to the mains network. This kind of system is suitable for processes where braking is needed often and the braking power is relatively high. In a non-regenerative system the braking power is redistributed to the other drives in the system via the common DC bus, and possible excess power can be dissipated as heat using an optional brake chopper unit and brake resistors. In small production lines or small paper machines

where braking is needed less often, a non-regenerative common DC bus system is a cost-efficient solution. In high power applications, it is possible to parallel multiple front-end units.

In addition to the welcome cost savings, you'll also benefit from reduced power cabling and installation time and reduced overall footprint of your drive system. Your drive line-up tolerance to voltage dips/sags will be improved and the harmonic distortions your drive system will be minimized.

IN HARMONY WITH THE ENVIRONMENT

Vacon is committed to being an environmentally responsible company and our energy saving products and solutions are a good example of that. Our Common DC bus portfolio fulfills key international standards and global requirements, including safety and EMC & Harmonics approvals. Likewise, we continue to develop innovative solutions utilizing ie. regenerative energy and smart grid technology to help customers effectively monitor and control energy use and costs.

PURE PERFORMANCE

Speed and torque control must be just right when manufacturing top-class stainless steel products. Vacon AC drives have been successfully implemented in various applications in the demanding metal processing industry.

VACON[®] NXP COMMON
DC BUS PRODUCTS



AIR COOLED DRIVE MODULES WITHIN THE VACON NXP COMMON DC BUS PRODUCT RANGE

WHAT'S IN IT FOR YOU

VACON NXP COMMON DC BUS

Typical segments	Key features	Benefits
<ul style="list-style-type: none"> • Metal • Pulp & paper • Crane systems • Mining & minerals • Marine 	Full power(0.55 to 2.2 MW) and voltage (380 to 690V) range for both induction and permanent magnet motors.	Same software tool, same control option boards allowing the maximum utilization of NXP features over a wide power range.
	Five built-in expansion slots for additional I/O, fieldbus and functional safety boards.	No additional modules required. Option boards are compact and easy to install at any time.
	Low harmonic regenerative front end. Cost effective non-regenerative front end.	Optimized drive system configurations enabling minimized overall investment cost. Excessive braking energy can be fed back to network saving energy costs.
	Compact drive modules and easy integration to cabinets.	Optimized module design reduces need for additional engineering and saves in cabinet space reducing overall costs.

TYPICAL APPLICATIONS

- Continuous web systems
- Metal lines eg. roller table systems
- Winders & unwinders
- Crane systems eg. main hoists, gantry & trolley drives
- Centrifuges
- Winches
- Conveyors
- Excavators

THE COMPLETE RANGE

Vacon's common DC bus product portfolio meets all the requirements with a flexible architecture, comprising a selection of active front-ends, non-regenerative front ends, inverters and brake choppers in the entire power range and voltages from 380 V to 690 V.

FLEXIBLE CONFIGURATION, CUSTOMIZED SOLUTIONS

Common DC bus components can be used in a multitude of combinations. In a typical DC bus configuration, the drives that are generating can transfer the energy directly to the drives in motoring mode. Common DC bus drive systems have different kinds of front-end units to meet the requirements of the electricity network and the process where the drives are used. With the right configuration, the drive system can achieve optimal performance and significant energy savings can be made when braking energy is utilized to its full potential.

FRONT-END UNITS

The front-end units convert a mains AC voltage and current into a DC voltage and current. The power is

transferred from the mains to a common DC bus and, in certain cases, vice versa.

ACTIVE FRONT-END (AFE)

The AFE unit is a bidirectional (regenerative) power converter for the front-end of a common DC bus drive line-up. An external LCL filter is used at the input. This unit is suitable in applications where low mains harmonics are required. AFE is able to boost DC link voltage (default +10%) higher than nominal DC link voltage (1,35x UN). AFE needs an external pre-charging circuit. However, AFE does not need any external grid side measurements to operate. AFE units can operate in parallel to provide increased power and/or redundancy without any drive to drive communication between the units. AFE units can also be connected to the same fieldbus with inverters, and controlled and monitored via fieldbus.

A regenerative common DC bus system

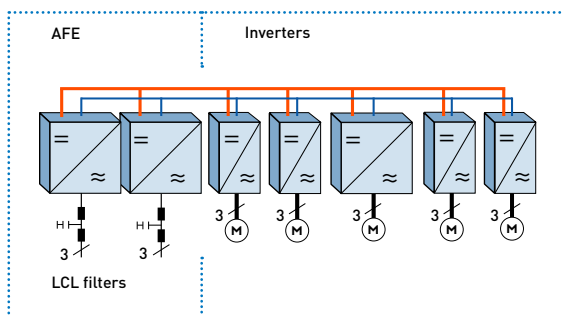

A non-regenerative common DC bus system

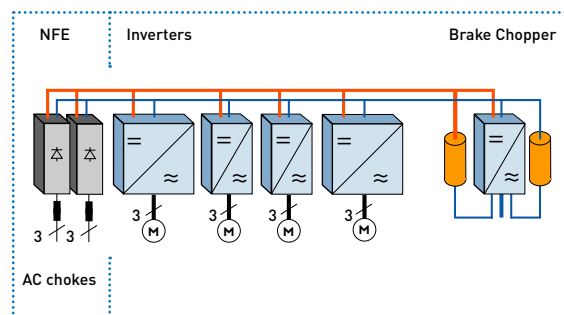

CONSISTENTLY RELIABLE

Vacon's proven performance, reliability and drive system modularity meet the needs of pulp & paper drive systems around the world.

TYPICAL DEVICE CONFIGURATIONS

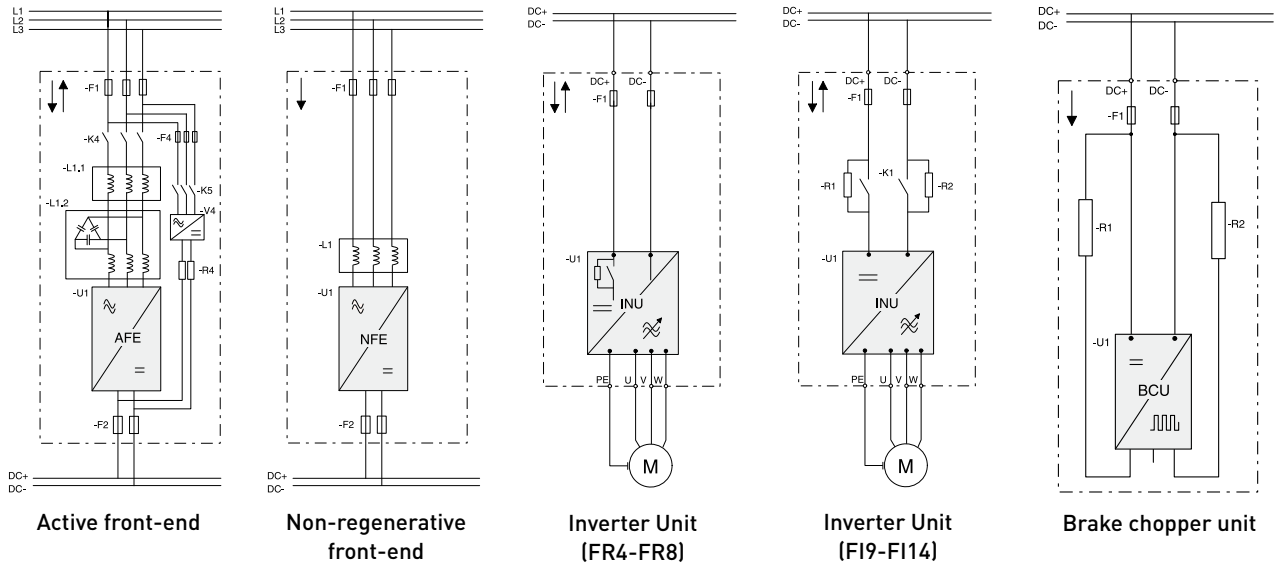

NON-REGENERATIVE FRONT-END (NFE)

The NFE unit is an unidirectional (motoring) power converter for the front-end of a common DC bus drive line-up. The NFE is a device that operates as a diode bridge using diode/thyristor components. A dedicated external choke is used at the input. The NFE unit has the capacity to charge a common DC bus, thus no external pre-charging is needed. This unit is suitable as a rectifying device when a normal level of harmonics is accepted and no regeneration to the mains is required. NFE units can be paralleled to increase power without any drive to drive communication between the units.

A common DC bus system consists of one or more front-end modules and inverter modules connected together by a DC bus

INVERTER UNIT

The INU (Inverter unit) is a bidirectional DC-fed power inverter for the supply and control of AC motors. The INU is supplied from a common DC bus drive line-up. A charging circuit is needed in case the connection possibility to a live DC bus is required. The DC side charging circuit is integrated for powers up to 75 kW (FR4-FR8) and externally located for higher power ratings (FI9-FI14).

BRAKE CHOPPER UNIT

The BCU (Brake chopper unit) is a unidirectional power converter for the supply of excessive energy from a common DC bus drive line-up to resistors where the energy is dissipated as heat. External resistors are needed. By using two brake resistors, the braking power of the brake chopper is doubled.

ELECTRICAL RATINGS

380-500 VAC INVERTER MODULES

Type	Unit			Low overload (AC current)		High overload (AC current)		I_{max}	
	Code	Frame		I_{L-cont} [A]	I_{1min} [A]	I_{H-cont} [A]	I_{1min} [A]	I_{2s} [A]	
INU	NXI	0004	5A2T0CSS	FR4	4.3	4.7	3.3	5.0	6.2
	NXI	0009	5A2T0CSS		9	9.9	7.6	11.4	14
	NXI	0012	5A2T0CSS		12	13.2	9	13.5	18
	NXI	0016	5A2T0CSS	FR6	16	17.6	12	18	24
	NXI	0022	5A2T0CSS		23	25.3	16	24	32
	NXI	0031	5A2T0CSS		31	34	23	35	46
	NXI	0038	5A2T0CSS	FR7	38	42	31	47	62
	NXI	0045	5A2T0CSS		46	51	38	57	76
	NXI	0072	5A2T0CSS		72	79	61	92	122
	NXI	0087	5A2T0CSS	FR8	87	96	72	108	144
	NXI	0105	5A2T0CSS		105	116	87	131	174
	NXI	0140	5A2T0CSS		140	154	105	158	210
	NXI	0168	5A0T0ISF	F19	170	187	140	210	280
	NXI	0205	5A0T0ISF		205	226	170	255	336
	NXI	0261	5A0T0ISF		261	287	205	308	349
	NXI	0300	5A0T0ISF	F110	300	330	245	368	444
	NXI	0385	5A0T0ISF		385	424	300	450	540
	NXI	0460	5A0T0ISF		460	506	385	578	693
	NXI	0520	5A0T0ISF	F112	520	572	460	690	828
	NXI	0590	5A0T0ISF		590	649	520	780	936
	NXI	0650	5A0T0ISF		650	715	590	885	1062
	NXI	0730	5A0T0ISF	F113	730	803	650	975	1170
	NXI	0820	5A0T0ISF		820	902	730	1095	1314
	NXI	0920	5A0T0ISF		920	1012	820	1230	1476
	NXI	1030	5A0T0ISF	F114	1030	1133	920	1380	1656
	NXI	1150	5A0T0ISF		1150	1265	1030	1545	1854
	NXI	1300	5A0T0ISF		1300	1430	1150	1725	2070
	NXI	1450	5A0T0ISF	F114	1450	1595	1300	1950	2340
	NXI	1770	5A0T0ISF		1770	1947	1600	2400	2880
	NXI	2150	5A0T0ISF		2150	2365	1940	2910	3492
NXI	2700	5A0T0ISF		2700	2970	2300	3278	3933	

525-690 VAC INVERTER MODULES

Type	Unit			Low overload (AC current)		High overload (AC current)		I_{max}	
	Code	Frame		I_{L-cont} [A]	I_{1min} [A]	I_{H-cont} [A]	I_{1min} [A]	I_{2s} [A]	
INU	NXI	0004	6A2T0CSS	FR6	4.5	5	3.2	5	6.4
	NXI	0005	6A2T0CSS		5.5	6	4.5	7	9
	NXI	0007	6A2T0CSS		7.5	8	5.5	8	11
	NXI	0010	6A2T0CSS	FR7	10	11	7.5	11	15
	NXI	0013	6A2T0CSS		13.5	15	10	15	20
	NXI	0018	6A2T0CSS		18	20	13.5	20	27
	NXI	0022	6A2T0CSS	FR8	22	24	18	27	36
	NXI	0027	6A2T0CSS		27	30	22	33	44
	NXI	0034	6A2T0CSS		34	37	27	41	54
	NXI	0041	6A2T0CSS	FR9	41	45	34	51	68
	NXI	0052	6A2T0CSS		52	57	41	62	82
	NXI	0062	6A2T0CSS		62	68	52	78	104
	NXI	0080	6A2T0CSS	F19	80	88	62	93	124
	NXI	0100	6A2T0CSS		100	110	80	120	160
	NXI	0125	6A0T0ISF		125	138	100	150	200
	NXI	0144	6A0T0ISF	F110	144	158	125	188	213
	NXI	0170	6A0T0ISF		170	187	144	216	245
	NXI	0208	6A0T0ISF		208	229	170	255	289
	NXI	0261	6A0T0ISF	F112	261	287	208	312	375
	NXI	0325	6A0T0ISF		325	358	261	392	470
	NXI	0385	6A0T0ISF		385	424	325	488	585
	NXI	0416	6A0T0ISF	F113	416	458	325	488	585
	NXI	0460	6A0T0ISF		460	506	385	578	693
	NXI	0502	6A0T0ISF		502	552	460	690	828
	NXI	0590	6A0T0ISF	F114	590	649	502	753	904
	NXI	0650	6A0T0ISF		650	715	590	885	1062
	NXI	0750	6A0T0ISF		750	825	650	975	1170
	NXI	0820	6A0T0ISF	F114	820	902	650	975	1170
	NXI	0920	6A0T0ISF		920	1012	820	1230	1476
	NXI	1030	6A0T0ISF		1030	1133	920	1380	1656
NXI	1180	6A0T0ISF	F114	1180	1298	1030	1464	1755	
NXI	1500	6A0T0ISF		1500	1650	1300	1950	2340	
NXI	1900	6A0T0ISF		1900	2090	1500	2250	2700	
NXI	2250	6A0T0ISF		2250	2475	1900	2782	3335	

380-500 VAC FRONT-END MODULES

Type	Unit		Low overload (AC current)		High overload (AC current)		DC Power *	
	Code	Frame	I _{L-cont} [A]	I _{1min} [A]	I _{H-cont} [A]	I _{1min} [A]	400 V mains P _{L-cont} (kW)	500 V mains P _{L-cont} (kW)
AFE	1 x NXA 0261 5 A0T02SF	1 x FI9	261	287	205	308	176	220
	1 x NXA 0460 5 A0T02SF	1 x FI10	460	506	385	578	310	388
	2 x NXA 0460 5 A0T02SF	2 x FI10	875	962	732	1100	587	735
	1 x NXA 1300 5 A0T02SF	1 x FI13	1300	1430	1150	1725	876	1092
	2 x NXA 1300 5 A0T02SF	2 x FI13	2470	2717	2185	3278	1660	2075
	3 x NXA 1300 5 A0T02SF	3 x FI13	3705	4076	3278	4916	2490	3115
NFE	4 x NXA 1300 5 A0T02SF	4 x FI13	4940	5434	4370	6550	3320	4140
	1 x NXN 0650 6 X0T0SSV	1 x FI9	650	715	507	793	410	513
	2 x NXN 0650 6 X0T0SSV	2 x FI9	1235	1359	963	1507	780	975
	3 x NXN 0650 6 X0T0SSV	3 x FI9	1853	2038	1445	2260	1170	1462
	4 x NXN 0650 6 X0T0SSV	4 x FI9	2470	2717	1927	3013	1560	1950
	5 x NXN 0650 6 X0T0SSV	5 x FI9	3088	3396	2408	3767	1950	2437
	6 x NXN 0650 6 X0T0SSV	6 x FI9	3705	4076	2890	4520	2340	2924

* In case you need to recalculate the power, please use the following formulas:

$$P_{H-cont} = P_{L-cont} \times \frac{I_{H-cont}}{I_{L-cont}}$$

$$P_{1min} = P_{L-cont} \times 1.1 \text{ (Low overload)}$$

$$P_{1min} = P_{H-cont} \times 1.5 \text{ (High overload)}$$

$$P_{L-cont} \times \frac{U_x}{400 \text{ V}}$$

525 - 690 VAC FRONT-END MODULES

Type	Unit		Low overload (AC current)		High overload (AC current)		DC Power *
	Code	Frame	I _{L-cont} [A]	I _{1min} [A]	I _{H-cont} [A]	I _{1min} [A]	690 V mains P _{L-cont} (kW)
AFE	1 x NXA 0170 6 A0T02SF	1 x FI9	170	187	144	216	198
	1 x NXA 0325 6 A0T02SF	1 x FI10	325	358	261	392	378
	2 x NXA 0325 6 A0T02SF	2 x FI10	634	698	509	764	716
	1 x NXA 1030 6 A0T02SF	1 x FI13	1030	1133	920	1380	1195
	2 x NXA 1030 6 A0T02SF	2 x FI13	2008	2209	1794	2691	2270
	3 x NXA 1030 6 A0T02SF	3 x FI13	2987	3286	2668	4002	3405
NFE	4 x NXA 1030 6 A0T02SF	4 x FI13	3965	4362	3542	5313	4538
	1 x NXN 0650 6X0T0SSV	1 x FI9	650	715	507	793	708
	2 x NXN 0650 6X0T0SSV	2 x FI9	1235	1359	963	1507	1345
	3 x NXN 0650 6X0T0SSV	3 x FI9	1853	2038	1445	2260	2018
	4 x NXN 0650 6X0T0SSV	4 x FI9	2470	2717	1927	3013	2690
	5 x NXN 0650 6X0T0SSV	5 x FI9	3088	3396	2408	3767	3363
	6 x NXN 0650 6X0T0SSV	6 x FI9	3705	4076	2890	4520	4036

* In case you need to recalculate the power, please use the following formulas:

$$P_{H-cont} = P_{L-cont} \times \frac{I_{H-cont}}{I_{L-cont}}$$

$$P_{1min} = P_{L-cont} \times 1.1 \text{ (Low overload)}$$

$$P_{1min} = P_{H-cont} \times 1.5 \text{ (High overload)}$$

$$P_{L-cont} \times \frac{U_x}{690 \text{ V}}$$

DIMENSIONS & WEIGHTS

Type	Frame	H (mm)	W (mm)	D (mm)	Weight (kg)
Power Module	FR4	292	128	190	5
	FR6	519	195	237	16
	FR7	591	237	257	29
	FR8	758	289	344	48
	FI9	1030	239	372	67
	FI10	1032	239	552	100
	FI12	1032	478	552	204
	FI13	1032	708	553	306
	FI14*	1032	2*708	553	612

Type	Suitability	H (mm)	W (mm)	D (mm)	Weight (kg)
LCL-filter	AFE FI9	1775	291	515	241 / 245 *
	AFE FI10	1775	291	515	263 / 304 *
	AFE FI13	1442	494	525	477 / 473 *
AC-Choke	NFE	449	497	249	130

* weight is different for 500 / 690 V versions, other dimensions are identical for both voltage classes

* only as inverter unit

ELECTRICAL RATINGS

380-500 VAC BRAKE-CHOPPER MODULES

Type	Unit		Frame	Braking current I_{L-cont}^* [A]	Min. Braking resistor (Per resistor)		Continuous braking power		
	Code				540 VDC [Ω]	675 VDC [Ω]	540 VDC [kW]	675 VDC P [kW]	
BCU	NXB	0004	5A2T08SS	FR4	8	159.30	199.13	5	6
	NXB	0009	5A2T08SS		18	70.80	88.50	11	14
	NXB	0012	5A2T08SS		24	53.10	66.38	15	19
	NXB	0016	5A2T08SS	FR6	32	39.83	49.78	20	25
	NXB	0022	5A2T08SS		44	28.96	36.20	28	35
	NXB	0031	5A2T08SS		62	20.55	25.69	40	49
	NXB	0038	5A2T08SS		76	16.77	20.96	48	61
	NXB	0045	5A2T08SS	FR7	90	14.16	17.70	57	72
	NXB	0061	5A2T08SS		122	10.45	13.06	78	97
	NXB	0072	5A2T08SS		148	8.61	10.76	94	118
	NXB	0087	5A2T08SS	FR8	174	7.32	9.16	111	139
	NXB	0105	5A2T08SS		210	6.07	7.59	134	167
	NXB	0140	5A2T08SS	FI9	280	4.55	5.69	178	223
	NXB	0168	5A0T08SF		336	3.79	4.74	214	268
	NXB	0205	5A0T08SF		410	3.11	3.89	261	327
	NXB	0261	5A0T08SF		522	2.44	3.05	333	416
	NXB	0300	5A0T08SF	FI10	600	2.12	2.66	382	478
	NXB	0385	5A0T08SF		770	1.66	2.07	491	613
	NXB	0460	5A0T08SF		920	1.39	1.73	586	733
	NXB	0520	5A0T08SF	FI13	1040	1.23	1.53	663	828
NXB	1150	5A0T08SF	2300		0.55	0.69	1466	1832	
NXB	1300	5A0T08SF	2600		0.49	0.61	1657	2071	
NXB	1450	5A0T08SF		2900	0.44	0.55	1848	2310	

525 - 690 VAC BRAKE CHOPPER MODULES

Type	Unit		Frame	Braking current I_{L-cont}^* [A]	Min. Braking resistor (Per resistor)		Continuous braking power		
	Code				708 VDC [Ω]	931 VDC [Ω]	708 VDC P [kW]	931 VDC P [kW]	
BCU	NXB	0004	6A2T08SS	FR6	8	238.36	274.65	6.7	9
	NXB	0005	6A2T08SS		10	190.69	219.72	8	11
	NXB	0007	6A2T08SS		14	136.21	156.94	12	15
	NXB	0010	6A2T08SS		20	95.34	109.86	17	22
	NXB	0013	6A2T08SS		26	73.34	84.51	22	29
	NXB	0018	6A2T08SS		36	52.97	61.03	30	40
	NXB	0022	6A2T08SS		44	43.34	49.94	37	48
	NXB	0027	6A2T08SS		54	35.31	40.69	45	59
	NXB	0034	6A2T08SS		68	28.04	32.31	57	75
	NXB	0041	6A2T08SS		FR7	82	23.25	26.79	69
	NXB	0052	6A2T08SS	104		18.34	21.13	87	114
	NXB	0062	6A2T08SS	FR8	124	15.38	17.72	104	136
	NXB	0080	6A2T08SS		160	11.92	13.73	134	176
	NXB	0100	6A2T08SS		200	9.53	10.99	167	220
	NXB	0125	6A0T08SF	FI9	250	7.63	8.79	209	275
	NXB	0144	6A0T08SF		288	6.62	7.63	241	316
	NXB	0170	6A0T08SF		340	5.61	6.46	284	374
	NXB	0208	6A0T08SF		416	4.58	5.28	348	457
	NXB	0261	6A0T08SF	FI10	522	3.65	4.21	436	573
	NXB	0325	6A0T08SF		650	2.93	3.38	543	714
	NXB	0385	6A0T08SF		770	2.48	2.85	643	846
	NXB	0416	6A0T08SF	FI13	832	2.29	2.64	695	914
	NXB	0920	6A0T08SF		1840	1.04	1.19	1537	2021
	NXB	1030	6A0T08SF		2060	0.93	1.07	1721	2263
	NXB	1180	6A0T08SF		2360	0.81	0.93	1972	2593

* total braking current

Standard features	INU					AFE	NFE	BCU					
	NXI AAAA V			NXA AAAA V	NXN AAAA V	NXB AAAA V							
	FR4, 6, 7	FR8	FI9 - FI14	FI9 - FI13	FI9	FR4, 6, 7	FR8	FI9 - FI13					
IP00													
IP21	●					●							
IP54	○					○							
Air cooling	●	●	●	●	●	●	●	●					
Standard board	●	●	●	●	●	●	●	●					
Varnished board					●								
Alphanumeric keypad	●	●	●	●	●	●	●	●					
EMC class T [EN 61800-3 for IT networks]	●	●	●	●	●	●	●	●					
Safety CE / UL	●	●	●	●	●	●	●	●					
Line reactor, external (required)					○								
LCL filter, external (required)					○								
No integrated charging			●	●				●					
Integrated charging (DC side)	●	●			●	●	●						
Diode/thyristor rectifier					●								
IGBT	●	●	●	●	●	●	●	●					
Standard I/O	Card slot					Number of I/O channels							
	A	B	C	D	E								
OPT-A1 Binary input (24 VDC)						6	6	6	6	n/a	6	6	6
OPT-A1 Binary output (24 VDC)						1	1	1	1	n/a	1	1	1
OPT-A1 Analog input						2	2	2	2	n/a	2	2	2
OPT-A1 Analog output						1	1	1	1	n/a	1	1	1
OPT-D7 Voltage measurement						-	-	-	z	n/a	-	-	-
OPT-A2 Relay output (NO/NC)						2	2	2	2	2 (NO)	2	2	2
Options													
Optional I/O cards													
OPT-A3 Relay output + Thermistor input						○	○	○	○	n/a	○	○	○
OPT-A4 Encoder TTL type						○	○	○	-	n/a	-	-	-
OPT-A5 Encoder HTL type						○	○	○	-	n/a	-	-	-
OPT-A7 Double encoder HTL type						○	○	○	-	n/a	-	-	-
OPT-A8 I/O as OPT-A1 (galvanic isolation)						○	○	○	○	n/a	○	○	○
OPT-A9 I/O as OPT-A1 (2.5 mm ² terminals)						○	○	○	○	n/a	○	○	○
OPT-AE Encoder HTL type (Divider + direction)						○	○	○	-	n/a	-	-	-
OPT-AF Safe disable EN954-1, cat 3						○	○	○	-	n/a	-	-	-
I/O expander cards (OPT-B)													
OPT-B1 Selectable I/O						○	○	○	○	n/a	○	○	○
OPT-B2 Relay output						○	○	○	○	n/a	○	○	○
OPT-B4 Analog input/output						○	○	○	○	n/a	○	○	○
OPT-B5 Relay output						○	○	○	○	n/a	○	○	○
OPT-B8 PT100						○	○	○	○	n/a	○	○	○
OPT-B9 Binary input + RO						○	○	○	○	n/a	○	○	○
OPT-BB + EnDat + Sin/Cos 1 Vp-p						○	○	○	-	n/a	-	-	-
OPT-BC Encoder out = Resolver simulation						○	○	○	-	n/a	-	-	-
Fieldbus cards (OPT-C)													
OPT-C2 RS-485 (Multiprotocol)						○	○	○	○	n/a	○	○	○
OPT-C3 Profibus DP						○	○	○	○	n/a	○	○	○
OPT-C4 LonWorks						○	○	○	○	n/a	○	○	○
OPT-C5 Profibus DP (D9-type connector)						○	○	○	○	n/a	○	○	○
OPT-C6 CANopen (slave)						○	○	○	○	n/a	○	○	○
OPT-C7 DeviceNet						○	○	○	○	n/a	○	○	○
OPT-C8 RS-485 (Multiprotocol, D9-type connector)						○	○	○	○	n/a	○	○	○
OPT-CG SELMA 2 protocol (SAMI)						○	○	○	○	n/a	○	○	○
OPT-CI Modbus / TCP (Ethernet)						○	○	○	○	n/a	○	○	○
OPT-CP Profinet I/O (Ethernet)						○	○	○	○	n/a	○	○	○
OPT-CQ Ethernet I/P (Ethernet)						○	○	○	○	n/a	○	○	○
Communication cards (OPT-D)													
OPT-D1 System Bus adapter (2 x fiber optic pairs)						○	○	○	○	n/a	○	○	○
OPT-D2 System Bus adapter (1 x fiber optic pair) & CAN-bus adapter (galvanically decoupled)						○	○	○	○	n/a	○	○	○
OPT-D3 RS232 adapter card (galvanically decoupled), used mainly for application engineering to connect another keypad						○	○	○	○	n/a	○	○	○
OPT-D6 CAN-bus adapter (galvanically decoupled)						○	○	○	○	n/a	○	○	○
OPT-D7 Voltage measurement card						○	○	○	○	n/a	-	-	-

● = included ○ = optional

Supply connection	Input voltage U_{in} [AC] Front-end modules	380-500 VAC / 525-690 VAC -10%...+10% [according to EN60204-1]
	Input voltage U_{in} [DC] Inverter and brake chopper modules	465...800 VDC / 640...1100 VDC. The voltage ripple of the inverter supply voltage, formed in rectification of the electric network's alternating voltage in basic frequency, must be less than 50 V peak-to-peak
	Output voltage U_{out} [AC] Inverter	$3 - 0 \dots U_{in} / 1.4$
	Output voltage U_{out} [DC] Active front-end module	$1.10 \times 1.35 \times U_{in}$ (Factory default)
	Output voltage U_{out} [DC] non-regenerative front-end module	$1.35 \times U_{in}$
Control characteristics	Control performance	Open loop vector control (5-150% of base speed): speed control 0.5%, dynamic 0.3%sec, torque lin. <2%, torque rise time -5 ms Closed loop vector control (entire speed range): speed control 0.01%, dynamic 0.2% sec, torque lin. <2%, torque rise time -2 ms
	Switching frequency	NX_5: 1...16 kHz; Factory default 10 kHz From NX_0072: 1...6 kHz; Factory default 3.6 kHz NX_6: 1...6 kHz; Factory default 1.5 kHz
	Field weakening point	8...320 Hz
	Acceleration time	0...3000 sec
	Deceleration time	0...3000 sec
	Braking	DC brake: 30% of T_N (without brake resistor), flux braking
	Ambient conditions	Ambient operating temperature
Storage temperature		-40°C...+70°C
Relative humidity		0 to 95% RH, non-condensing, non-corrosive, no dripping water
Air quality: - chemical vapours - mechanical particles		IEC 721-3-3, unit in operation, class 3C2 IEC 721-3-3, unit in operation, class 3S2
Altitude		100% load capacity (no derating) up to 1000 m 1.5% derating for each 100 m above 1000 m Max. altitudes: NX_5: 3000 m; NX_6: 2000 m
Vibration EN50178/EN60068-2-6		FR4 - FR8: Displacement amplitude 1 mm (peak) at 5...15.8 Hz Max acceleration 1 G at 15.8...150 Hz FI9 - FI13: Displacement amplitude 0.25 mm (peak) at 5...31 Hz Max acceleration 1 G at 31...150 Hz
Shock EN50178, EN60068-2-27		UPS Drop Test (for applicable UPS weights) Storage and shipping: max 15 G, 11 ms (in package)
Cooling capacity required		approximately 2%
Cooling air required		FR4 70 m³/h, FR6 425 m³/h, FR7 425 m³/h, FR8 650 m³/h FI9 1150 m³/h, FI10 1400 m³/h, FI12 2800 m³/h, FI13 4200 m³/h
Unit enclosure class		FR8, FI9 - 14 (IP00); FR4 - 7 (IP21)
EMC (at default settings)	Immunity	Fulfills all EMC immunity requirements, level T
Safety		CE, UL, CUL, EN 61800-5-1 [2003], see unit nameplate for more detailed approvals
Functional safety *	STO	EN/IEC 61800-5-2 Safe Torque Off (STO) SIL2, EN ISO 13849-1 PL "d" Category 3, EN 62061: SILCL2, IEC 61508: SIL2.
	SS1	EN/IEC 61800-5-2 Safe Stop 1 (SS1) SIL2, EN ISO 13849-1 PL "d" Category 3, EN/IEC62061: SILCL2, IEC 61508: SIL2.
	ATEX Thermistor input	94/9/EC, CE 0537 Ex 11 [2] GD
Control connections	Analogue input voltage	0...+10 V, $R_i = 200 \text{ k}\Omega$, (-10 V...+10 V joystick control) Resolution 0.1%, accuracy $\pm 1\%$
	Analogue input current	0(4)...20 mA, $R_i = 250 \Omega$ differential
	Digital inputs	6, positive or negative logic; 18...30 VDC
	Auxiliary voltage	+24 V, $\pm 15\%$, max. 250 mA
	Output reference voltage	+10 V, +3%, max. load 10 mA
	Analogue output	0(4)...20 mA; R_i max. 500 Ω ; resolution 10 bits Accuracy $\pm 2\%$
	Digital outputs	Open collector output, 50 mA / 48 V
	Relay outputs	2 programmable change-over relay outputs Switching capacity: 24 VDC / 8 A, 250 VAC / 8 A, 125 VDC / 0.4 A Min. switching load: 5 V / 10 mA
Protections	Overvoltage protection	NX_5: 911 VDC; NX_6: 1200 VDC
	Undervoltage protection	NX_5: 333 VDC; NX_6: 460 VDC
	Earth fault protection	Yes
	Motor phase supervision	Trips if any of the output phases is missing
	Overcurrent protection	Yes
	Unit overtemperature protection	Yes
	Motor overload protection	Yes
	Motor stall protection	Yes
	Motor underload protection	Yes
Short-circuit protection of +24 V and +10 V reference voltages	Yes	

WE ARE DRIVES

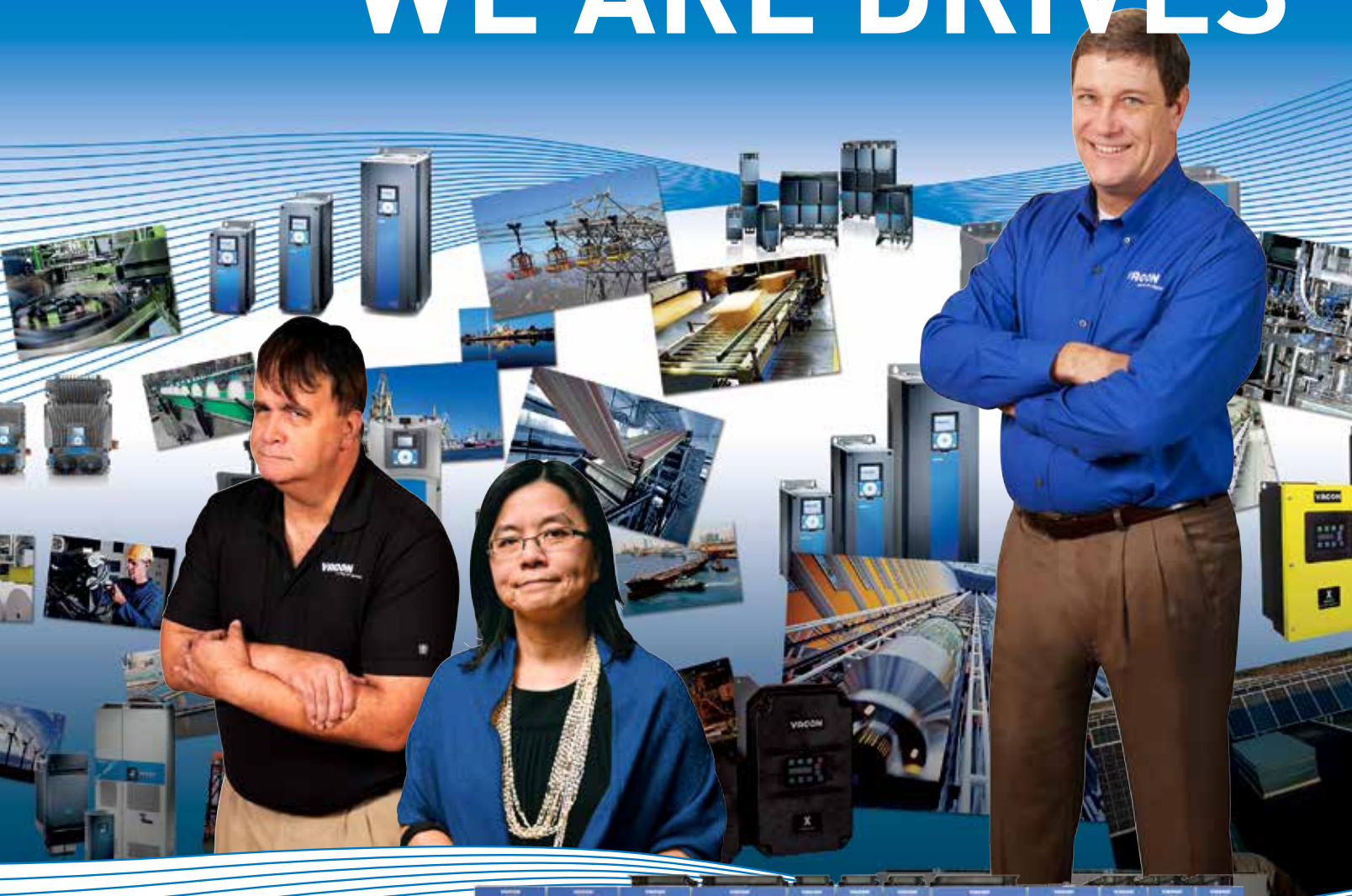

VACON[®] NXP SYSTEM DRIVE



VACON - THE BEST PARTNER FOR RELIABILITY AND PERFORMANCE

Customers in heavy industries, such as Marine, Metals and Pulp & Paper, need drive systems that excel in terms of reliable performance. If you can rely on your system, it leaves you with more time and money to spend on optimizing the rest of the application. Vacon recognizes this, which is why we've been at the forefront of the drive systems business for the past twenty years.

You can now be sure to receive a drive system that is unmatched in terms of quality and ready in a shorter space of time than ever before. That's because we have changed our production approach to bring it into line with what customers are after. VACON® NXP System Drive ensures that you receive an excellent level of quality and service, each and every time.

People – partners and employees alike – are what make Vacon. Nowhere is this truer than in the system drives business. These kinds of large-scale projects often feature many different components which are reliant upon communication on both sides to avoid technical problems anywhere down the line.

DRIVEN BY DRIVES

Our ability to work around the challenges our customers face everyday, regarding efficiency and cost savings, is

the reason why we have reached where we are so quickly. As a company that's focused 100% on AC drives, we live by their performance. By choosing Vacon, you can be sure to receive a top-class drive system – nothing else will do. We also won't compete with system integrators for projects, unlike many other drive suppliers. This enables an atmosphere of mutual trust with our network of system integrators and end-users.

COMPLEX SOLUTIONS MADE SIMPLE

It's essential that you receive a solution with a level of quality that's as consistent as it is excellent. VACON® NXP System Drive provides complex solutions which are simplified through standardization, resulting in a product that will easily integrate into the process. This doesn't prevent you from getting the exact solution you need – we can tailor some elements of the system in order to meet your requirements.



VACON® NXP SYSTEM DRIVE - QUALITY AS STANDARD

RELIABILITY IS KEY

VACON® NXP System Drive brings what customers need above all else – consistent and reliable quality guaranteed. We excel in delivering verified and tested solutions that combine VACON AC Drives, DC bus components and options. No need to worry about waiting for technical data, documentation or piloting – we've done all that before it reaches your premises.

QUICK INSTALLATION

Aside from the quality delivered, VACON® NXP System drive is also easy to adapt. Engineered sections slot in alongside each other, allowing you to arrange integrated transport splits to save space. Alternatively, you can add extra transport sections to speed up installation. All larger modules have slide-out mechanics that facilitate setup and maintenance. This also enables late module delivery, which can be helpful if the system is to be installed in a harsh environment. All sections are grouped depending on their functionality, making it possible to plan each installation phase exactly how you wish.

COST EFFICIENCY

Besides the peace of mind that comes with stress-free installation and setup, you'll also save a lot of time and money. This is because the setup is essentially formulated when you order it, meaning system integrators can get on with designing the rest of the application. The fact that the drive system's setup is uniform also means that it's far easier to provide spare parts.

SAFETY AND SERVICE MEANS A LONGER LIFECYCLE

A complex and wide-ranging solution is not one you want to have to replace, which is why VACON® NXP System Drive is built to last. One of the cornerstones of Vacon's relationship with our partners is a commitment to drives performance that goes far beyond the point of purchase. Items such as busbar systems and high/low power devices are separated into individual compartments, away from each other. This means that, if things go wrong, the problem is compartmentalized and doesn't cause widespread failure. The fact that VACON NXP System Drive is easy to maintain also makes it safer. Service engineers are immediately familiar with the way the system is set up, meaning they can get straight to the focal point.

PROVEN AC DRIVE TECHNOLOGY FOR HEAVY INDUSTRY

Still need a reason to choose Vacon? How about the fact that VACON® NXP drives have been leading the way in the industry for the past decade. Aside from frequency converter units, Vacon can also deliver software and common DC bus components, which combine to make your personal solution. VACON® NXP Common DC bus technology has been the choice for our drive system customers for many years already – VACON NXP® System Drive simply ensures an optimal version of this solution, consistently and quickly.



VACON® NXP
SYSTEM DRIVE

KEY BENEFITS

Complete drive solutions

- Standardized products which fit all your application needs
- Modules can be delivered closer to start of the operation
- Minimized lifetime cost

Premium quality

- **Industry-leading VACON® NXP & VACON® Common DC bus solutions**
- **Safe, tested and verified design**
- **Comprehensive documentation available with each delivery**

Save on time and cost

- Modular design equipped with pull out feature for quick setup & maintenance
- Short setup time
- Easy to train onsite engineers

TYPICAL APPLICATIONS



Marine & Offshore

- Cranes & Hoists
- Thrusters
- Deck machinery



Metals

- Metal plane lines
- Melting and casting
- Rolling mill applications



Pulp & paper

- Conveyors
- Sectional drives
- Debarking drums

AUXILIARY DEVICE SECTION (ADS)

The auxiliary device section includes the common line-up controls. This section can be customized for all application and segment needs. There is one ADS size available.

ADS type	Dimensions, W x H x D (mm)
ADS_600	600 x 2000 x 605

As standard the ADS section has the following equipment:

- Control for the circuit breaker with +ICB selected
- Indication of the mains status (fault, pre-charging and ON)
- Auxiliary power supply 24 V, 5 A
- Auxiliary Transformer, 2500 VA 1-phase supply (in bottom of cabinet)
- Terminals for control and monitoring

As pre-engineered standard options, we can provide the following:

- Emergency stop CAT0 (+PES)
- Emergency stop CAT1 (+PED)
- Insulation fault sensor (+PIF)
- Arc protection (+PAP)*
- Cabinet heater (+ACH)
- Cabinet light (+ACL)
- Auxiliary voltage transformer 4000 VA (+AT4)
- Auxiliary voltage 110 VAC (+AT1)
- Auxiliary power supply 24 V, 10 A (+ADC)
- Cabling from the top (+CIT)
- Empty auxiliary 600 mm cabinet with door (+G60)
- UL approved design and components (+NAR)
- Customer specific option (+CSO)

* +PAP will have sub units in selected sections if needed, please refer to the circuit diagrams.

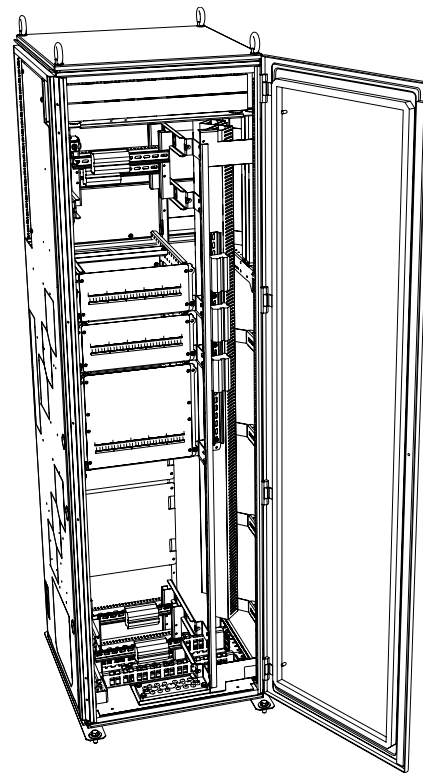

VACON[®] NXP
SYSTEM DRIVE

MAIN INCOMING SECTION (MIS)

The main incoming section includes the main incoming device. The main incoming device and size is dependent on the required current of the complete line-up.

MIS type	Input current	Dimensions, W x H x D (mm)
MIS_630	630 A	400 x 2000 x 605
MIS_1000	1000 A	600 x 2000 x 605
MIS_1250	1250 A	600 x 2000 x 605
MIS_1600	1600 A	600 x 2000 x 605
MIS_2500	2500 A	600 x 2000 x 605
MIS_3200	3200 A	800 x 2000 x 605
MIS_4000	4000 A	800 x 2000 x 605

As standard the MIS section has the following equipment:

- Main incoming device, Load Switch
- Mains connections
- Emergency disconnect push button
- Digital multi instrument with field bus connection

As pre-engineered standard options we can provide the following:

- Air Circuit breaker (+ICB)
- Cabling from the top (+CIT)
- Earth Switch (+ILE)*
- Current transducers (+ITR)
- UL approved design and components (+NAR)
- Arc protection (+PAP)
- Cabinet heater (+ACH)
- Cabinet light (+ACL)

* +ILE requires an additional section.

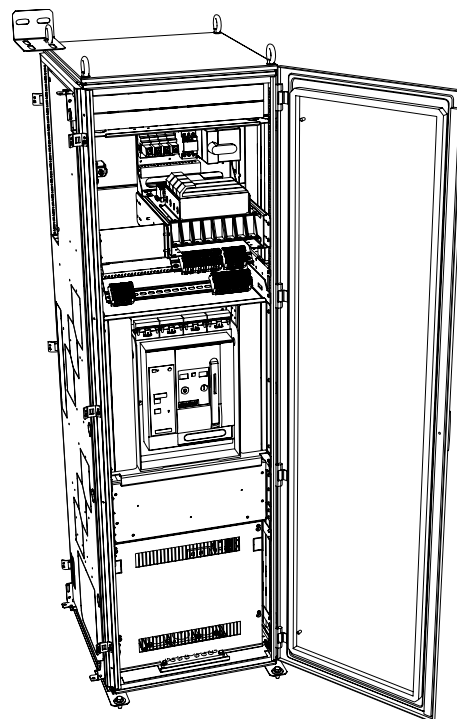

AVAILABLE SECTIONS

NON-REGENERATIVE FRONT-END SECTION (NFS)

The non-regenerative front-end section (NFS) includes one or multiple NXN units from the VACON® product family. The NXN is a non-regenerative supply unit that can be utilized in 6-pulse, 12-pulse, 18-pulse and 24-pulse systems.

NFS type	Number of NXN units	Dimensions, W x H x D (mm)
NFS_1x	1	400 x 2000 x 605
NFS_2x	2	600 x 2000 x 605
NFS_3x	3	800 x 2000 x 605

As standard the NFS section includes the following:

- The NXN unit(s)
- Chokes
- Terminals for control and indication signals
- DC fuses for the Supply Unit
- AC fuses for the filter

As pre-engineered standard options, we can provide the following:

- UL approved design and components (+NAR)
- Arc protection (+PAP)
- Cabinet heater (+ACH)
- Cabinet light (+ACL)

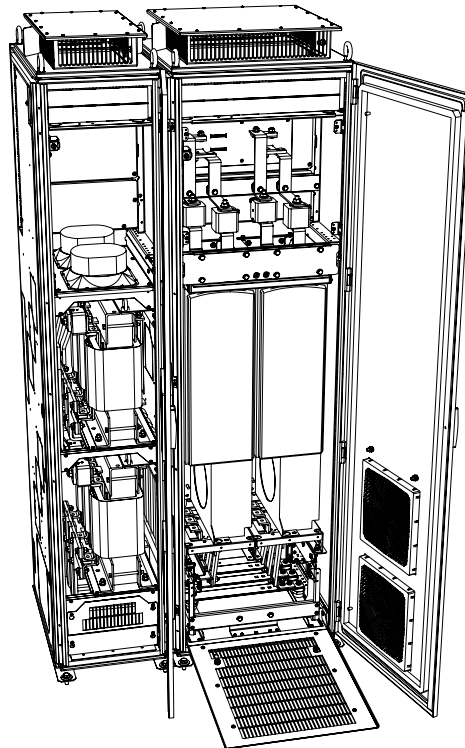

ACTIVE FRONT-END SECTION (AFS)

The active front-end section includes an LCL-filter and an NXA unit from the VACON® product family. The active front-end provides low THD(I) and several units can be connected in parallel providing full or reduced redundancy.

AFS type	Drive size	Dimensions, W x H x D (mm)
AFS_9	F19	800 x 2000 x 605*
AFS_10	F110	800 x 2000 x 605*
AFS_13	F113	1400 x 2000 x 605*

* Dimensions including LCL

As standard the AFS sections include the following:

- LCL Filter
- The NXA unit
- Control unit
- Pre-charging components
- Terminals for control and indication signals
- DC fuses for the Supply Unit
- AC fuses for the filter

As pre-engineered standard options we can provide the following:

- UL approved design and components (+NAR)
- Arc protection (+PAP)
- Cabinet heater (+ACH)
- Cabinet light (+ACL)

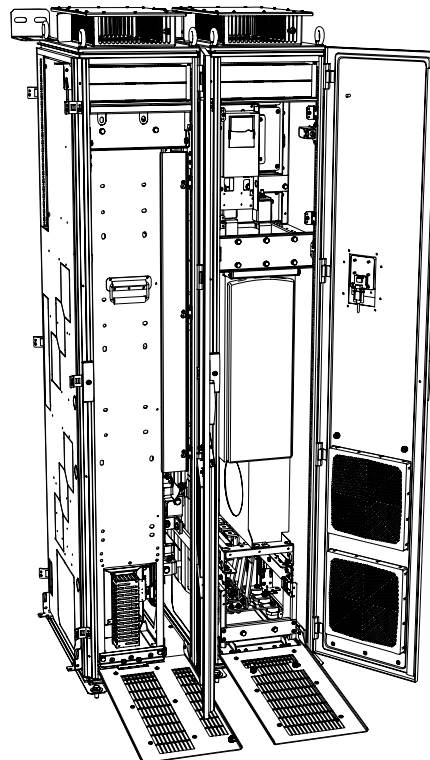

INVERTER UNIT SECTION (IUS) DRIVE SIZES FR4-FR8

The inverter unit section (IUS) includes one or several smaller NXI drives from the VACON® product family. The inverter units are all VACON® NXP drives.

IUS type	Drive size	Maximum amount of units per section	Dimensions, W x H x D (mm)
IUS_4	FR4	3*	400 x 2000 x 605**
IUS_4/6	FR4/FR6	2	400 x 2000 x 605**
IUS_7	FR7	1	400 x 2000 x 605**
IUS_8	FR8	1	400 x 2000 x 605**

* Only option board and fieldbus options

** Top exit +400mm can be shared between two sections

As standard the IUS section includes the following:

- Input fuses (DC fuses)
- The NXI drive(s)
- Control box (integrated into the module)
- Terminals for control and indication signals

As pre-engineered standard options we can provide the following:

- dU/dt (+ODU)
- Common mode filter (+OCM)
- SINE filter (+OSI)
- Input Switch with charging (+ISC)
- Input Switch, DC-disconnect (+ISD)
- Arc detection (+ADU)
- Motor fan control (+AMF)
- Motor heater feeder (+AMH)
- Mechanical break control (+AMB)
- Section light (+SLT)
- Top cabling (+COT)
- UL approved design and components (+NAR)
- Arc protection (+PAP)
- Cabinet heater (+ACH)
- Cabinet light (+ACL)

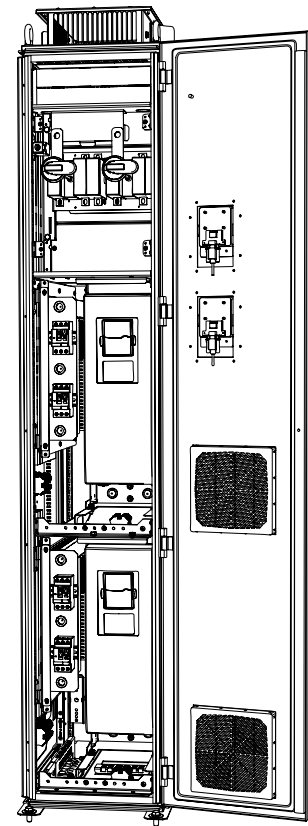

VACON® NXP
SYSTEM DRIVE

INVERTER UNIT SECTION (IUS) DRIVE SIZES FI9-FI14

The inverter unit section (IUS) includes the largest NXI drives from the VACON® product family. The inverter units are all VACON® NXP drives.

MIS type	Drive size	Dimensions, W x H x D (mm)	Dimensions, W x H x D (mm) with space optimization
IUS_9	FI9	800 x 2000 x 605	600 x 2000 x 605
IUS_10	FI10	800 x 2000 x 605	600 x 2000 x 605
IUS_12	FI12	1000 x 2000 x 605	Not available
IUS_13	FI13	1400 x 2000 x 605	Not available
IUS_14	FI14	2400 x 2000 x 605	Not available

As standard the IUS section includes the following:

- Input fuses (DC fuses)
- The NXI drive
- Service platform/module removal
- Outlet for power (for PC etc.)
- Control section and fixed external terminals, 70 pcs

As pre-engineered standard options we can provide the following:

- dU/dt (+ODU)
- Common mode filter (+OCM)
- SINE filter (+OSI)
- Input Switch with charging (+ISC)
- Input Switch, DC-disconnect (+ISD)
- Arc detection (+ADU)
- Motor fan control (+AMF)
- Motor heater feeder (+AMH)
- Mechanical break control (+AMB)
- Section light (+SLT)
- Top cabling (+COT)
- UL approved design and components (+NAR)
- Arc protection (+PAP)
- Cabinet heater (+ACH)
- Cabinet light (+ACL)

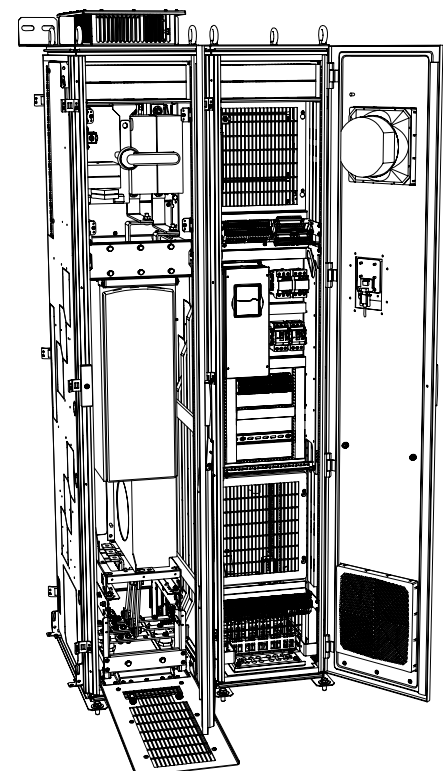



NXP SYSTEM DRIVE OPTION AVAILABILITY

Plus Code	Description	Incoming Sections		Front End Sections		Inverter Sections	
		ADS	MIS	NFS	AFS	IUS (FR4-8)	IUS (FI9-14)
+ACH	Cabinet Heater	0	0	0	0	0	0
+ACL	Cabinet Light	0	0	0	0	0	0
+ADC	Auxiliary Power Supply - 24V, 10A	0	-	-	-	-	-
+ADU	Arc Detection	-	-	-	-	0	0
+AMB	Mechanical Break Control	-	-	-	-	0	0
+AMF	Motor Fan Control	-	-	-	-	0	0
+AMH	Motor Heater Feeder	-	-	-	-	0	0
+AT1	Auxiliary Voltage - 110VAC	0	-	-	-	-	-
+AT4	Auxiliary Voltage Transformer - 4kVA	0	-	-	-	-	-
+CIT	Cable Entry from Top	0	0	-	-	-	-
+COT	Top Cabling	-	-	-	-	0*	0
+CSO	Customer Specific Option	0	-	-	-	-	-
+G60	Empty Auxiliary 600mm Cabinet with Door	0	-	-	-	-	-
+ICB	Air Circuit Breaker	-	0	-	-	-	-
+ILE	Earth Switch	-	0*	-	-	-	-
+ISC	Input Switch with Charging	-	-	-	-	0	0
+ISD	Input Switch, DC-Disconnect	-	-	-	-	0	0
+ITR	Current Transducers	-	0	-	-	-	-
+NAR	UL Approved Design and Components	0	0	0	0	0	0
+OCM	Common Mode Filter	-	-	-	-	0	0
+ODU	dU/dt [dV/dt] Output Filter	-	-	-	-	0	0
+OSI	SINE Filter	-	-	-	-	0	0
+PAP	Arc Protection	0	0	0	0	0	0
+PED	Emergency Stop CAT 1	0	-	-	-	-	-
+PES	Emergency Stop CAT 0	0	-	-	-	-	-
+PIF	Insulation Fault Sensor	0	-	-	-	-	-
+SLT	Section Light	-	-	-	-	0	0

*May Require Additional Cabinet Sections

WE ARE DRIVES



VACON[®] NXP LIQUID COOLED



VACON® NXP
LIQUID COOLED

QUIET. COMPACT. COOL.

VACON NXP liquid cooled drives are the ultimate in space-saving, high power density AC drives, well suited for locations where air-cooling is difficult, expensive or impractical or where installation space is at a premium. Their robust, modular design makes the VACON NXP a suitable platform for all drive needs in demanding applications and are available in the power range from 7.5 to 5300 kW at 380-690 VAC supply voltages.

POWER PACKED

As no air ducts are required, liquid cooled drives are extremely compact and suitable for a wide variety of heavy industries with harsh operating conditions such as marine & offshore, pulp & paper, renewable energy and mining & metal. The VACON NXP liquid cooled drive is an advanced AC drive for induction and permanent magnet motors.

As a high degree of protection (IP54 or higher) can easily be achieved with these drives, they can be installed almost anywhere in the plant/vessel. This significantly reduces the load on the air-conditioning system in the electrical rooms – an important cost and space consideration in many retrofit applications. And since liquid cooled drives do not require large cooling fans, they are also among the most silent AC drive on the market.

We are committed to providing you with the ultimate in high power density. VACON NXP liquid cooled products

have one of the best power/size ratios on the market. For example, our compact 12 pulse, 1.5MW drive includes a built-in rectifier, inverter and optional brake all in same package and can be mounted in an 800mm wide enclosure. Once you've tried liquid cooled, you'll never look back.

IN HARMONY WITH THE ENVIRONMENT

Vacon is also committed to being an environmentally responsible company and our energy saving products and solutions are a good example of that. Our Vacon liquid cooled portfolio fulfills all relevant international standards and global requirements, including marine, safety and EMC & Harmonics approvals. Likewise, we continue to develop innovative solutions utilizing ie. regenerative energy and smart grid technology to help customers effectively monitor and control energy use and costs.



SAVING FUEL AT SEA

In the highly competitive marine sector, increased demand for efficiency is the main reason for using AC drives in fan, winch, propeller, and various special applications across all vessel types, from large luxury liners and cargo ships to tugboats.



VACON® NXP
LIQUID COOLED

WHAT'S IN IT FOR YOU

VACON NXP LIQUID COOLED PRODUCT RANGE

Typical segments	Key features	Benefits
<ul style="list-style-type: none"> • Marine & offshore • Metal • Renewable energy • Mining & minerals • Water & wastewater • Power stations • Pulp & paper • Oil & gas • Machine building 	Full power range from 7.5 to 5.3 MW for both induction motors and permanent magnet motors.	Same software tool, same control option boards allowing for maximum utilization of NXP features over a wide power range.
	Five built-in expansion slots for additional I/O, fieldbus and functional safety boards	No additional modules required. Option boards are compact and easy to install at any time
	Extensive range of ready-to-use applications for basic to demanding needs.	No additional software engineering required, saving time and money.
	High-tech liquid cooled AC drive design, heat loss can be transferred to most convenient place with no need for vast amount of filtered air.	Minimizes investment and operation costs as there is no need for large air conditioning systems. Liquid cooled AC drives installed in high IP class enclosures can be used in demanding environments.
	Compact size and high power density	Possibility to engineer compact solutions that save on floor space and infrastructure needs.



THE LIQUID WAY TO STAY COOL

When comparing cooling technology solutions, it is important to understand the effects on the infrastructure of the electrical room, and the room's requirements. Additional comparison parameters are the geographical location, relevant industry/segment and process.

CLIMATE CONSIDERATIONS

In warm climates it is extremely important to observe the amount of heat load transferred to the electrical room because it is in direct relationship to the electrical energy consumption.

The type-tested switchgears standard EN 60439-1 specifies that the electrical room's 24-hour average temperature should be below +35°C and the maximum temporary temperature cannot exceed +40°C. As a result, the cooling system in electrical rooms is typically comprised of air conditioning chillers, which are dimensioned according to the maximum heat load, the temperature inside the electrical room and the maximum temperature outdoors. The typical electrical energy consumption of air conditioning is approx. 25 - 33% of the cooling power.

The initial investment in liquid cooled AC drives technology is slightly higher than in air cooled AC drives

technology given the unique cooling pipe arrangements and heat exchanger systems. It is also important to consider that a heat exchanger should be compared with ventilation and air conditioning systems with ventilation ducts, ventilation machines and ventilation automation systems.

THE HIGHER THE POWER, THE GREATER THE SAVINGS

Since there is no requirement to provide additional air conditioning capacity or extra ventilation for the areas in which the drives are used, liquid cooled drives may therefore be the most cost-effective option. Likewise, the related savings enable shorter payback times and the higher the power, the greater the savings potential.

The electrical energy cost trend certainly supports a wider use of liquid cooled drives technology, and the number of on-shore installations is growing rapidly.

EXCLUSIVELY DESIGNED FOR LIQUID COOLING

The VACON NXP liquid cooled dissipates less than 5% of its total heat losses to air, only 0.1...0.15% of the drive rated load. A high-tech cooling heatsink enables better cooling efficiency and makes the cooling utilization ratio of the components higher than ever. Many other liquid cooled drives on the market are based on modifications of an air cooled drive, rather than exclusively designed for the purpose.

A DRIVING FORCE IN WIND ENERGY

Vacon products, including liquid cooled drives are essential components in windmill installations that convert kinetic energy produced by the rotating blades into AC power for the local electricity grid.

COOLING TECHNOLOGY ADVANTAGES

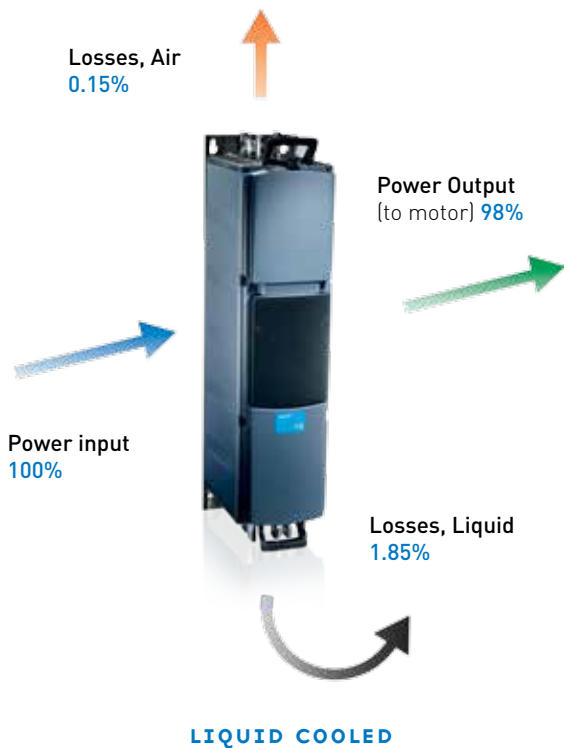

VS



VACON® NXP
LIQUID COOLED

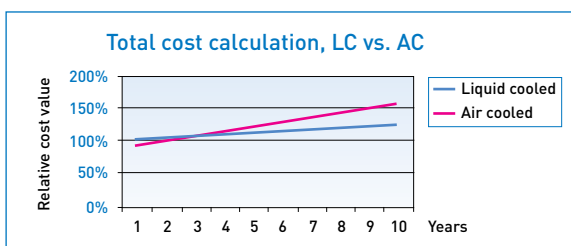

A 400 kW, 690 VAC liquid cooled drive is:

- 32 % of the volume of the air cooled drive
- 50 % of the width of the air cooled drive
- 70 % of the weight of the air cooled drive
- 20 dBA more silent than the air cooled drive



EXTENSIVE PRODUCT PORTFOLIO

Liquid cooled AC drives can be used in a multitude of combinations - from a single dedicated frequency converter to large-scale Common DC bus systems. With the right configuration, optimal performance and significant energy savings can be achieved.

DEDICATED FREQUENCY CONVERTER

The Vacon liquid cooled single drives are available as 6- or 12-pulse frequency converters. Our largest unit, the CH74, can also be used as an 18-pulse converter. A frequency converter consists of a IP00 power unit, control unit and possibly one or more input chokes.

An internal brake chopper is available as standard for our smallest unit CH3. For CH72 (only 6-pulse) and CH74, it is available as internal option while in all other sizes the brake chopper is available as option and installed externally.

ACTIVE FRONT-END (AFE)

The AFE unit is a bi-directional (regenerative) power converter (supply unit) for the front-end of a common liquid cooled DC bus drive line-up. An external LCL filter is used at the input. This unit is suitable in applications where a low level of mains harmonics and high power factor are required. AFE units can operate in parallel to provide increased power and/or redundancy without any drive to drive communication between the units. AFE units can also be connected to the same fieldbus with

inverters, and controlled and monitored via fieldbus. Fuses, LCL filters, pre-charging rectifiers and resistors must be ordered and specified separately.

The LCL filter guarantees that harmonics are not an issue in any network. With a power factor > 0.99 and low harmonics, the supply chain transformers, generators, etc. can be sized very accurately without reserving margins for the reactive power. This can mean a saving of 10 % in supply chain investments. Likewise the payback time is faster as regenerative energy is fed back to the grid.

A regenerative common DC bus system

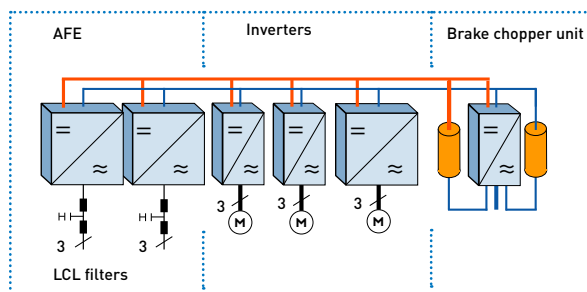

PURE PERFORMANCE

Speed and torque control must be accurate in order for many demanding production lines to reach optimum process control. Vacon AC drives have successfully been implemented in various applications across a wide spectrum of industries.

TYPICAL DEVICE CONFIGURATIONS

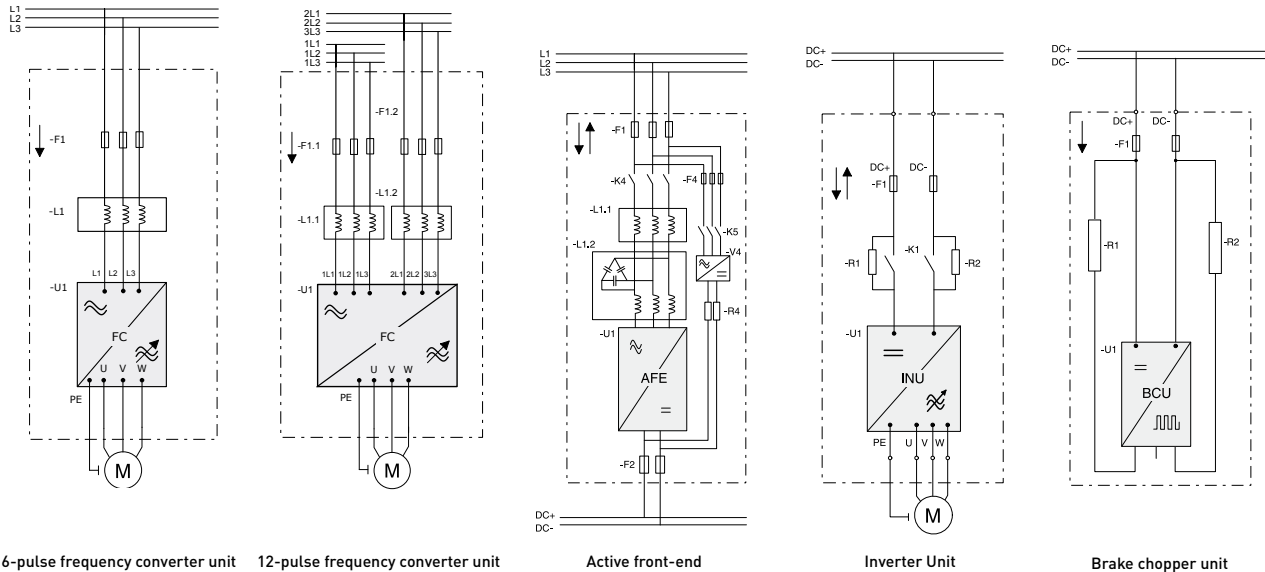

6-pulse frequency converter unit 12-pulse frequency converter unit

Active front-end

Inverter Unit

Brake chopper unit

INVERTER UNIT (INU)

The INU is a bidirectional DC-fed power inverter for the supply and control of AC motors. The INU is supplied from a common DC bus drive line-up. A charging circuit is needed in case a connection to a live DC bus is required. The DC-side charging circuit is external for inverter types.

Pre-charging resistors and switches or fuses are not included in an INU delivery and must be specified and ordered separately.

BRAKE CHOPPER UNIT (BCU)

The BCU is unidirectional power converter for the supply of excessive energy from a common DC bus drive line-up or big single drive to resistors where the energy is dissipated as heat. External resistors are required. However, resistors or fuses are not included in a BCU delivery and must be specified and ordered separately.

BCU's improve drive dynamic performance in a load regenerative operating point and protect common DC bus voltage level from overvoltage. In some cases they also reduce the need for AFE investments.

FUNCTIONAL SAFETY AND RELIABILITY

MARINE APPROVALS

With over 15 years of experience across a wide range of Marine & Offshore AC drives applications, Vacon liquid cooled AC drives fulfill type approvals of major classification societies:

- Type approval: DNV, BV, Lloyd's Register
- Delivery based approval: ABS, GL, Class NK, CCS, KR, RINA

We have delivered AC drives for over 700 propulsion drives systems and 1000 thrusters. Vacon has represented world-first and leading-pioneer AC drive technologies in several Marine & Offshore applications, e.g. diesel-electric propulsion systems with AFE drives, redundant electrical cargo pump systems, hybrid tugboats and shaft generator systems.



VACON NXP LIQUID COOLED ENCLOSED DRIVE

Vacon also offers high power liquid cooled engineered drive packages. For example, a single NXP CH64 cabinet solution can be used with AC motors in power sizes up to 1550kW. The power range can also be extended up to 5MW by using the innovative DriveSynch control concept.

Some of the advantages of this cabinet solution include:

- Bi-directional (regenerative) power converter, optimal performance and significant energy savings can be made when braking energy is utilized to its full potential.
- Current distortion below 5%
- Totally enclosed IP54 cabinet solutions that can be used in demanding environments and no need for large air conditioning systems
- Liquid cooled input and output filters
- Designed for easy installation and maintenance

The Vacon NXP is a state-of-the-art AC drive for use in all applications where robustness, dynamic performance, precision and power are required. Vacon NXP supports both induction motors and permanent magnet motors in open and closed loop control modes as well as high speed motors.



VACON® NXP
LIQUID COOLED

RATING AND DIMENSIONS

MAINS VOLTAGE 525-690 VAC

AC-Drive Type	Rated Current			Electrical Output Power		Chassis	Dimensions WxHxD W/O Cooling Skid [in]
	Thermal I _{TH} [A]	Cont. I _L [A]	Cont. I _H [A]	Motor at I _{TH} (525 VAC) [kW]	Motor at I _{TH} (690 VAC) [kW]		
0820_6	820	745	547	560	800	Ch64	78.41 x 82.67* x 35.43
0920_6	920	836	613	650	850	Ch64	78.41 x 82.67* x 35.43
1030_6	1030	936	687	700	1000	Ch64	78.41 x 82.67* x 35.43
1180_6	1180	1073	787	800	1100	Ch64	78.41 x 82.67* x 35.43
1300_6	1300	1182	867	900	1200	Ch64	78.41 x 82.67* x 35.43
1500_6	1500	1364	1000	1000	1400	Ch64	78.41 x 82.67* x 35.43
1700_6	1700	1545	1133	1150	1550	Ch64	78.41 x 82.67* x 35.43



VACON® NXP
LIQUID COOLED

DEDICATED MARINE APPLICATION

Our **Vacon Marine Application** provides flexibility and performance across all Marine segment applications. We have pioneered several technologies and applications in the field of Marine & Offshore such as redundant electrical cargo pump systems, liquid cooled AFE propulsion systems, pipe-laying tensioners and winches as well as oil exploration fibre cable winches.

Vacon liquid cooled drives fulfill all major approvals and bring many benefits to this segment in particular such as: energy efficiency, improved process availability due to high redundancy, better process quality and control, as well as silent operation and substantially reduced emissions.

- Added benefits:**
- Power extension with Drive Synch
 - Interface for power handling for power management system
 - Black Out prevention logics
 - Freely configurable PI control logic

INTELLIGENT SYSTEM INTERFACE

Our **Vacon System Interface Application (SIA)** provides flexible and extensive interface for use in coordinated drives, which have an overriding control system. The recommended interface to control the system is fieldbus communication through hardwired analogue and digital signals or via keypad and PC control.

Vacon SIA utilizes the most advanced functions of our NXP motor control software and is suitable for demanding drive systems such as those in the pulp & paper and metal industries, processing lines as well as many other standard applications.

- Added benefits:**
- Power extension with Drive Synch
 - Master Follower functions for torque sharing
 - Freely configurable PI control logic

LIQUID TO LIQUID HEAT EXCHANGERS

In cooperation with HVAC professionals, Vacon has designed a range of cooling units based on liquid-to-liquid heat exchangers (HX), which improve the availability and usability of AC drive systems. The cooling units belong to the liquid cooled VACON NXP range and offer reliable and cost-effective cooling without ventilation concerns.

PROVEN RELIABILITY

Vacon's standardized heat exchanger makes the use of liquid cooled drives easier, because a well-planned and sized unit is easier to apply than a project solution. In addition, a standard heat exchanger solution offers proven reliability.

To minimize the risk of possible leaks, splitting the cooling circuit into segments is worthwhile, because even in a large group of AC drives the volume of the liquid stays under 100 litres. An additional advantage of separated cooling segments is the opportunity to use inhibitors and glycol against corrosion, freezing and micro-organisms.

The Vacon heat exchanger has versatile protection and control functions. The whole system is supervised by the drive's control application software, which meets

the standards of our most demanding customers. The operation of the unit can be monitored by an upper level automation system. The system controls the cooling conditions of the drives and supervises the flow, while detecting any possible leaks in the cooling system.

The Vacon heat exchanger can be used in different types of electrical networks where frequencies and voltages may vary, as the cooling pump is controlled by an AC drive. Such networks are typically used in the marine industry and other electrical island networks using diesel generators. This solution offers the added advantage of being able to adjust the flow capacity to meet the demand. Higher than expected pressure losses within the cooling circuit may be easily compensated for by changing the speed of the pump, thus raising the pressure and flow.

A standard cooling unit delivery consists of:

- Self-supporting module rack construction, which can be integrated into generic switchgear and cabinet solutions
- Cooling circuit equipped with threaded joints or flanges
- Heavy industry PVC-C pipework, which is excellent as it is lightweight and prevents corrosion
- Industrial water heat exchanger, three-way-valve, pump, AC drive

Available cooling unit options:

- Stainless steel AISI piping
- Two-way-valve capable of optimizing the quantity of the cooling water, when the temperature of the process liquid is low
- Heat exchanger can be delivered installed inside a Rittal TS8 or VSG VEDA 5000 cabinet
- Double pumps can be selected for marine class requirements, types 120 kW and 300 kW
- Titanium heat exchanger is used in seawater circuits. The structure and performance differs from the fresh water models.



	HXL-M/V/R-040-N-P	HXL/M-M/V/R-120-N-P	HXS/T-M/V/R-070-N-P	HXL/M-M/R-300-N-P
Cooling power	0...40 kW	0...120 kW	0...69 kW	0...300 kW
Mains supply	380...420 VAC	380...420 VAC	380...420 VAC	380...500 VAC
Flow	40...120 l/min	120...360 l/min	120...200 l/min	360...900 l/min
Distribution pressure	0.3 bar / l=10 m, DN32*	HXL: 1 bar / l = 40 m, DN50 HXM: 0.7 bar / l = 30 m, DN50	HXS: 1 bar / l = 40 m, DN50 HXT: 0.7 bar / l = 25 m, DN50	HXL: 1 bar / l = 40 m, DN80 HXM: 0.7 bar / l = 25 m, DN80
Double pump		HXM	HXT	HXM
Cabinets	VEDA, Rittal	VEDA, Rittal	VEDA, Rittal	Rittal

* l = maximum distribution distance with specific DN diameter

VACON NXP LIQUID COOLED FREQUENCY CONVERTERS,
6-PULSE & 12-PULSE¹, MAINS VOLTAGE 400-500 VAC

AC drive type 6-pulse IP00			Drive output current			Motor shaft power		Power loss c/a/T* [kW]	Chassis	Choke type 6-pulse
			Thermal I _{th} [A]	Rated cont. I _L [A]	Rated cont. I _H [A]	Optimum motor at I _{th} (400V) [kW]	Optimum motor at I _{th} (500V) [kW]			
NXP	0016	5A0N1SWS	16	15	11	7.5	11	0.4/0.2/0.6	CH3	CHK0023N6A0
NXP	0022	5A0N1SWS	22	20	15	11	15	0.5/0.2/0.7		CHK0023N6A0
NXP	0031	5A0N1SWS	31	28	21	15	18.5	0.7/0.2/0.9		CHK0038N6A0
NXP	0038	5A0N1SWS	38	35	25	18.5	22	0.8/0.2/1.0		CHK0038N6A0
NXP	0045	5A0N1SWS	45	41	30	22	30	1.0/0.3/1.3		CHK0062N6A0
NXP	0061	5A0N1SWS	61	55	41	30	37	1.3/0.3/1.5		CHK0062N6A0
NXP	0072	5A0N1SWS	72	65	48	37	45	1.2/0.3/1.5	CH4	CHK0087N6A0
NXP	0087	5A0N1SWS	87	79	58	45	55	1.5/0.3/1.8		CHK0087N6A0
NXP	0105	5A0N1SWS	105	95	70	55	75	1.8/0.3/2.1		CHK0145N6A0
NXP	0140	5A0N1SWS	140	127	93	75	90	2.3/0.3/2.6		CHK0145N6A0
NXP	0168	5A0N1SWS	168	153	112	90	110	4.0/0.4/4.4	CH5	CHK0261N6A0
NXP	0205	5A0N1SWS	205	186	137	110	132	5.0/0.5/5.5		CHK0261N6A0
NXP	0261	5A0N1SWS	261	237	174	132	160	6.0/0.5/6.5		CHK0261N6A0
NXP	0300	5A0N0SWF	300	273	200	160	200	4.5/0.5/5.0	CH61	CHK0400N6A0
NXP	0385	5A0N0SWF	385	350	257	200	250	6.0/0.5/6.5		CHK0400N6A0
NXP	0460	5A0N0SWF	460	418	307	250	315	6.5/0.5/7.0	CH72	CHK0520N6A0
NXP	0520	5A0N0SWF	520	473	347	250	355	7.5/0.6/8.1		CHK0520N6A0
NXP	0590	5A0N0SWF	590	536	393	315	400	9.0/0.7/9.7		CHK0650N6A0
NXP	0650	5A0N0SWF	650	591	433	355	450	10.0/0.7/10.7		CHK0650N6A0
NXP	0730	5A0N0SWF	730	664	487	400	500	12.0/0.8/12.8		CHK0750N6A0
NXP	0820	5A0N0SWF	820	745	547	450	560	12.5/0.8/13.3		CHK0820N6A0
NXP	0920	5A0N0SWF	920	836	613	500	600	14.4/0.9/15.3	CH63	CHK1030N6A0
NXP	1030	5A0N0SWF	1030	936	687	560	700	16.5/1.0/17.5		CHK1030N6A0
NXP	1150	5A0N0SWF	1150	1045	766	600	750	18.5/1.2/19.7		CHK1150N6A0
NXP	1370	5A0N0SWF	1370	1245	913	700	900	19.0/1.2/20.2		3 x CHK0520N6A0
NXP	1640	5A0N0SWF	1640	1491	1093	900	1100	24.0/1.4/25.4	CH74	3 x CHK0650N6A0
NXP	2060	5A0N0SWF	2060	1873	1373	1100	1400	32.5/1.8/34.3		3 x CHK0750N6A0
NXP	2300	5A0N0SWF	2300	2091	1533	1250	1500	36.3/2.0/38.3	2 x CH74	3 x CHK0820N6A0
NXP	2470	5A0N0SWF	2470	2245	1647	1300	1600	38.8/2.2/41.0		6 x CHK0520N6A0
NXP	2950	5A0N0SWF	2950	2681	1967	1550	1950	46.3/2.6/48.9		6 x CHK0520N6A0
NXP	3710	5A0N0SWF	3710	3372	2473	1950	2450	58.2/3.0/61.2		6 x CHK0650N6A0
NXP	4140	5A0N0SWF	4140	3763	2760	2150	2700	65.0/3.6/68.6		6 x CHK0750N6A0
2 x NXP	2470	5A0N0SWF	4700	4300	3100	2450	3050	73.7/4.2/77.9		4 x CH74
2 x NXP	2950	5A0N0SWF	5600	5100	3700	2900	3600	88/5/93	12 x CHK0520N6A0	
2 x NXP	3710	5A0N0SWF	7000	6400	4700	3600	4500	110.6/5.7/116.3	12 x CHK0650N6A0	
2 x NXP	4140	5A0N0SWF	7900	7200	5300	4100	5150	123.5/6.9/130.4	12 x CHK0750N6A0	

I_{th} = Thermal maximum continuous RMS current. Dimensioning can be done according to this current if the process does not require any overloadability or the process does not include any load variation or margin for overloadability.

NOTE: Contact your local Vacon Sales Representative for more precise sizing and selection in all other cases.

*] c = power loss into coolant; a = power loss into air; T = total power loss; power losses of input chokes not included. All power losses obtained using max. supply voltage, I_{th} and switching frequency of 3.6 kHz and ClosedLoop control mode. All power losses are worst case losses.

¹: Contact your local Vacon Sales Representative for inquiries about 12-pulse solutions.

RATINGS AND DIMENSIONS

VACON NXP LIQUID COOLED FREQUENCY CONVERTERS, 6-PULSE & 12-PULSE¹, MAINS VOLTAGE 525-690 VAC

AC drive type 6-pulse			Drive output current			Motor shaft power		Power loss c/a/T* [kW]	Chassis	Choke type 6-pulse
			Thermal I _{th} [A]	Rated cont. I _L [A]	Rated cont. I _r [A]	Optimum motor at I _{th} (400V) [kW]	Optimum motor at I _r (500V) [kW]			
NXP	0170	6A0T0SWF	170	155	113	110	160	5.5/0.2/5.7	CH61	CHK0261N6A0
NXP	0208	6A0T0SWF	208	189	139	132	200	6.5/0.3/6.8		CHK0261N6A0
NXP	0261	6A0T0SWF	261	237	174	160	250	6.5/0.3/6.8		CHK0261N6A0
NXP	0325	6A0T0SWF	325	295	217	200	300	7.5/0.4/7.9	CH72	CHK0400N6A0
NXP	0385	6A0T0SWF	385	350	257	250	355	9.0/0.5/9.5		CHK0400N6A0
NXP	0416	6A0T0SWF	416	378	277	250	355	9.4/0.5/9.9		CHK0520N6A0
NXP	0460	6A0T0SWF	460	418	307	300	400	10.0/0.5/10.5		CHK0520N6A0
NXP	0502	6A0T0SWF	502	456	335	355	450	12.0/0.6/12.6		CHK0520N6A0
NXP	0590	6A0T0SWF	590	536	393	400	560	13.0/0.7/13.7	CH63	CHK0650N6A0
NXP	0650	6A0T0SWF	650	591	433	450	600	16.0/0.8/16.8		CHK0650N6A0
NXP	0750	6A0T0SWF	750	682	500	500	700	18.0/0.9/18.9		CHK0750N6A0
NXP	0820	6A0T0SWF	820	745	547	560	800	19.0/1.0/20.0	CH74	3 x CHK0400N6A0
NXP	0920	6A0T0SWF	920	836	613	650	850	21.3/1.2/22.5		3 x CHK0400N6A0
NXP	1030	6A0T0SWF	1030	936	687	700	1000	22.0/1.1/23.1		3 x CHK0400N6A0
NXP	1180	6A0T0SWF	1180	1073	787	800	1100	25.0/1.3/26.3		3 x CHK0400N6A0
NXP	1300	6A0T0SWF	1300	1182	867	900	1200	31.0/1.6/32.6		3 x CHK0520N6A0
NXP	1500	6A0T0SWF	1500	1364	1000	1050	1400	38.0/1.9/39.9		3 x CHK0520N6A0
NXP	1700	6A0T0SWF	1700	1545	1133	1150	1550	38.0/1.9/39.9		3 x CHK0650N6A0
NXP	1850	6A0T0SWF	1850	1682	1233	1250	1650	39.6/2.0/41.6		6 x CHK0400N6A0
NXP	2120	6A0T0SWF	2120	1927	1413	1450	1900	45.0/2.4/47.4		6 x CHK0400N6A0
NXP	2340	6A0T0SWF	2340	2127	1560	1600	2100	55.8/2.9/58.7		2 x CH74
NXP	2700	6A0T0SWF	2700	2455	1800	1850	2450	68.4/3.4/71.8	6 x CHK0520N6A0	
NXP	3100	6A0T0SWF	3100	2818	2066	2150	2800	68.4/3.4/71.8	6 x CHK0520N6A0	
2 x NXP	1850	6A0T0SWF	3500	3200	2300	2400	3150	75.2/3.8/79	4 x CH74	12 x CHK0400N6A0
2 x NXP	2120	6A0T0SWF	4000	3600	2700	2750	3600	85.5/4.6/90.1		12 x CHK0400N6A0
2 x NXP	2340	6A0T0SWF	4400	4000	2900	3050	3950	106/5.5/111.5		12 x CHK0400N6A0
2 x NXP	2700	6A0T0SWF	5100	4600	3400	3500	4600	130/6.5/136.5		12 x CHK0520N6A0
2 x NXP	3100	6A0T0SWF	5900	5400	3900	4050	5300	130/6.5/136.5		12 x CHK0520N6A0

¹: Contact your local Vacon Sales Representative for inquiries about 12-pulse solutions.

STANDARD AIR COOLED CHOKES FOR VACON NX LIQUID COOLED PRODUCT RANGE

Choke type	Losses to air [kW]	Dimensions WxHxD [mm]	Weight [kg]
CHK0023N6A0	145	230 x 179 x 121	10
CHK0038N6A0	170	270 x 209 x 145	15
CHK0062N6A0	210	300 x 214 x 160	20
CHK0087N6A0	250	300 x 233 x 170	26
CHK0145N6A0	380	200 x 292 x 185	37
CHK0261N6A0	460	354 x 357 x 230	53
CHK0400N6A0	610	350 x 421 x 262	84
CHK0520N6A0	810	497 x 446 x 244	115
CHK0650N6A0	890	497 x 496 x 244	130
CHK0750N6A0	970	497 x 527 x 273	170
CHK0820N6A0	1020	497 x 529 x 275	170
CHK1030N6A0	1170	497 x 677 x 307	213
CHK1150N6A0	1420	497 x 677 x 307	213

VACON NXP LIQUID COOLED INVERTER UNITS, DC BUS VOLTAGE 465-800 VDC

AC drive type			Drive output current			Motor shaft power		Power loss c/a/T* [kW]	Chassis
			Thermal I _{th} [A]	Rated cont. I _L [A]	Rated cont. I _H [A]	Optimum motor at I _{th} (540 VDC) [kW]	Optimum motor at I _H (675 VDC) [kW]		
NXP	0016	5A0T1IWS	16	15	11	7.5	11	0.4/0.2/0.6	CH3
NXP	0022	5A0T1IWS	22	20	15	11	15	0.5/0.2/0.7	
NXP	0031	5A0T1IWS	31	28	21	15	18.5	0.7/0.2/0.9	
NXP	0038	5A0T1IWS	38	35	25	18.5	22	0.8/0.2/1.0	
NXP	0045	5A0T1IWS	45	41	30	22	30	1.0/0.3/1.3	
NXP	0061	5A0T1IWS	61	55	41	30	37	1.3/0.3/1.5	
NXP	0072	5A0T0IWS	72	65	48	37	45	1.2/0.3/1.5	CH4
NXP	0087	5A0T0IWS	87	79	58	45	55	1.5/0.3/1.8	
NXP	0105	5A0T0IWS	105	95	70	55	75	1.8/0.3/2.1	
NXP	0140	5A0T0IWS	140	127	93	75	90	2.3/0.3/2.6	
NXP	0168	5A0T0IWS	168	153	112	90	110	2.5/0.3/2.8	CH5
NXP	0205	5A0T0IWS	205	186	137	110	132	3.0/0.4/3.4	
NXP	0261	5A0T0IWS	261	237	174	132	160	4.0/0.4/4.4	
NXP	0300	5A0T0IWF	300	273	200	160	200	4.5/0.4/4.9	CH61
NXP	0385	5A0T0IWF	385	350	257	200	250	5.5/0.5/6.0	
NXP	0460	5A0T0IWF	460	418	307	250	315	5.5/0.5/6.0	CH62
NXP	0520	5A0T0IWF	520	473	347	250	355	6.5/0.5/7.0	
NXP	0590	5A0T0IWF	590	536	393	315	400	7.5/0.6/8.1	
NXP	0650	5A0T0IWF	650	591	433	355	450	8.5/0.6/9.1	
NXP	0730	5A0T0IWF	730	664	487	400	500	10.0/0.7/10.7	
NXP	0820	5A0T0IWF	820	745	547	450	560	12.5/0.8/13.3	CH63
NXP	0920	5A0T0IWF	920	836	613	500	600	14.4/0.9/15.3	
NXP	1030	5A0T0IWF	1030	936	687	560	700	16.5/1.0/17.5	
NXP	1150	5A0T0IWF	1150	1045	766	600	750	18.4/1.1/19.5	
NXP	1370	5A0T0IWF	1370	1245	913	700	900	15.5/1.0/16.5	CH64
NXP	1640	5A0T0IWF	1640	1491	1093	900	1100	19.5/1.2/20.7	
NXP	2060	5A0T0IWF	2060	1873	1373	1100	1400	26.5/1.5/28.0	
NXP	2300	5A0T0IWF	2300	2091	1533	1250	1500	29.6/1.7/31.3	
NXP	2470	5A0T0IWF	2470	2245	1647	1300	1600	36.0/2.0/38.0	2 x CH64
NXP	2950	5A0T0IWF	2950	2681	1967	1550	1950	39.0/2.4/41.4	
NXP	3710	5A0T0IWF	3710	3372	2473	1950	2450	48.0/2.7/50.7	
NXP	4140	5A0T0IWF	4140	3763	2760	2150	2700	53.0/3.0/56.0	
2 x NXP	2470	5A0T0IWF	4700	4300	3100	2450	3050	69.1/3.9/73	4 x CH64
2 x NXP	2950	5A0T0IWF	5600	5100	3700	2900	3600	74.4/4.6/79	
2 x NXP	3710	5A0T0IWF	7000	6400	4700	3600	4500	90.8/5.2/96	
2 x NXP	4140	5A0T0IWF	7900	7200	5300	4100	5150	101.2/5.8/107	

The voltage classes for the inverter units used in the tables above have been defined as follows:

Input 540 VDC = Rectified 400 VAC supply
 Input 675 VDC = Rectified 500 VAC supply

VACON® NXP
LIQUID COOLED

RATINGS AND DIMENSIONS

VACON NXP LIQUID COOLED INVERTER UNITS, DC BUS VOLTAGE 640-1100 VDC

AC drive type			Drive output current			Motor shaft power		Power loss c/a/T* [kW]	Chassis
			Thermal I _{th} [A]	Rated cont. I _L [A]	Rated cont. I _H [A]	Optimum motor at I _{th} (710 VDC) [kW]	Optimum motor at I _H (930 VDC) [kW]		
NXP	0170	6A0T0IWF	170	155	113	110	160	4.5/0.2/4.7	CH61
NXP	0208	6A0T0IWF	208	189	139	132	200	5.5/0.3/5.8	
NXP	0261	6A0T0IWF	261	237	174	160	250	5.5/0.3/5.8	
NXP	0325	6A0T0IWF	325	295	217	200	300	6.5/0.3/6.8	CH62
NXP	0385	6A0T0IWF	385	350	257	250	355	7.5/0.4/7.9	
NXP	0416	6A0T0IWF	416	378	277	250	355	8.0/0.4/8.4	
NXP	0460	6A0T0IWF	460	418	307	300	400	8.5/0.4/8.9	
NXP	0502	6A0T0IWF	502	456	335	355	450	10.0/0.5/10.5	CH63
NXP	0590	6A0T0IWF	590	536	393	400	560	10.0/0.5/10.5	
NXP	0650	6A0T0IWF	650	591	433	450	600	13.5/0.7/14.2	
NXP	0750	6A0T0IWF	750	682	500	500	700	16.0/0.8/16.8	CH64
NXP	0820	6A0T0IWF	820	745	547	560	800	16.0/0.8/16.8	
NXP	0920	6A0T0IWF	920	836	613	650	850	18.0/0.9/18.9	
NXP	1030	6A0T0IWF	1030	936	687	700	1000	19.0/1.0/20.0	
NXP	1180	6A0T0IWF	1180	1073	787	800	1100	21.0/1.1/22.1	
NXP	1300	6A0T0IWF	1300	1182	867	900	1200	27.0/1.4/28.4	
NXP	1500	6A0T0IWF	1500	1364	1000	1050	1400	32.0/1.6/33.6	
NXP	1700	6A0T0IWF	1700	1545	1133	1150	1550	38.0/1.9/39.9	
NXP	1850	6A0T0IWF	1850	1682	1233	1250	1650	34.2/1.8/36.0	2 x CH64
NXP	2120	6A0T0IWF	2120	1927	1413	1450	1900	37.8/2.0/39.8	
NXP	2340	6A0T0IWF	2340	2127	1560	1600	2100	48.6/2.5/51.1	
NXP	2700	6A0T0IWF	2700	2455	1800	1850	2450	57.6/3.0/60.6	
NXP	3100	6A0T0IWF	3100	2818	2066	2150	2800	68.4/3.4/71.8	4 x CH64
2 x NXP	1850	6A0T0IWF	3500	3200	2300	2400	3150	75.2/3.8/79	
2 x NXP	2120	6A0T0IWF	4000	3600	2700	2750	3600	85.5/4.6/90.1	
2 x NXP	2340	6A0T0IWF	4400	4000	2900	3050	3950	106/5.5/111.5	
2 x NXP	2700	6A0T0IWF	5100	4600	3400	3500	4600	130/6.5/136.5	
2 x NXP	3100	6A0T0IWF	5900	5400	3900	4050	5300	130/6.5/136.5	

The voltage classes for the inverter units used in the tables above have been defined as follows:

Input 710 VDC = Rectified 525 VAC supply
 Input 930 VDC = Rectified 690 VAC supply

VACON NXP LIQUID COOLED DIMENSIONS: DRIVES CONSISTING OF ONE MODULE

Chassis	Width [mm]	Height [mm]	Depth [mm]	Weight [kg]
CH3	160	431	246	15
CH4	193	493	257	22
CH5	246	553	264	40
CH61/62	246	658	372	55
CH63	505	923	375	120
Ch64	746	923	375	180
CH72	246	1076	372	90
Ch74	746	1175	385	280

One-module drive dimensions (mounting base included)
 Please note that AC chokes are not included

VACON NXA LIQUID COOLED ACTIVE FRONT-END, DC BUS VOLTAGE 465-800 VDC

AC drive type			AC Current			DC power				Power loss c/a/T* (kW)	Chassis
			Thermal I _{th} [A]	Rated I _L [A]	Rated I _n [A]	400 VAC mains I _{th} (kW)	500 VAC mains I _{th} (kW)	400 VAC mains I _L (kW)	500 VAC mains I _L (kW)		
NXA	0168	5A0T02WS	168	153	112	113	142	103	129	2.5/0.3/2.8	CH5
NXA	0205	5A0T02WS	205	186	137	138	173	125	157	3.0/0.4/3.4	
NXA	0261	5A0T02WS	261	237	174	176	220	160	200	4.0/0.4/4.4	
NXA	0300	5A0T02WF	300	273	200	202	253	184	230	4.5/0.4/4.9	CH61
NXA	0385	5A0T02WF	385	350	257	259	324	236	295	5.5/0.5/6.0	
NXA	0460	5A0T02WF	460	418	307	310	388	282	352	5.5/0.5/6.0	CH62
NXA	0520	5A0T02WF	520	473	347	350	438	319	398	6.5/0.5/7.0	
NXA	0590	5A0T02WF	590	536	393	398	497	361	452	7.5/0.6/8.1	
NXA	0650	5A0T02WF	650	591	433	438	548	398	498	8.5/0.6/9.1	
NXA	0730	5A0T02WF	730	664	487	492	615	448	559	10.0/0.7/10.7	CH63
NXA	0820	5A0T02WF	820	745	547	553	691	502	628	10.0/0.7/10.7	
NXA	0920	5A0T02WF	920	836	613	620	775	563	704	12.4/0.8/12.4	
NXA	1030	5A0T02WF	1030	936	687	694	868	631	789	13.5/0.9/14.4	
NXA	1150	5A0T02WF	1150	1045	767	775	969	704	880	16.0/1.0/17.0	CH64
NXA	1370	5A0T02WF	1370	1245	913	923	1154	839	1049	15.5/1.0/16.5	
NXA	1640	5A0T02WF	1640	1491	1093	1105	1382	1005	1256	19.5/1.2/20.7	
NXA	2060	5A0T02WF	2060	1873	1373	1388	1736	1262	1578	26.5/1.5/28.0	
NXA	2300	5A0T02WF	2300	2091	1533	1550	1938	1409	1762	29.6/1.7/31.3	

VACON NXA LIQUID COOLED ACTIVE FRONT-END, DC BUS VOLTAGE 640-1100 VDC

AC drive type			AC Current			DC power				Power loss c/a/T* (kW)	Chassis
			Thermal I _{th} [A]	Rated I _L [A]	Rated I _n [A]	525 VAC mains I _{th} (kW)	690 VAC mains I _{th} (kW)	525 VAC mains I _L (kW)	690 VAC mains I _L (kW)		
NXA	0170	6A0T02WF	170	155	113	150	198	137	180	4.5/0.2/4.7	CH61
NXA	0208	6A0T02WF	208	189	139	184	242	167	220	5.5/0.3/5.8	
NXA	0261	6A0T02WF	261	237	174	231	303	210	276	5.5/0.3/5.8	
NXA	0325	6A0T02WF	325	295	217	287	378	261	343	6.5/0.3/6.8	CH62
NXA	0385	6A0T02WF	385	350	257	341	448	310	407	7.5/0.4/7.9	
NXA	0416	6A0T02WF	416	378	277	368	484	334	439	8.1/0.4/8.4	
NXA	0460	6A0T02WF	460	418	307	407	535	370	486	8.5/0.4/8.9	
NXA	0502	6A0T02WF	502	456	335	444	584	403	530	10.0/0.5/10.5	CH63
NXA	0590	6A0T02WF	590	536	393	522	686	474	623	10.0/0.5/10.5	
NXA	0650	6A0T02WF	650	591	433	575	756	523	687	13.5/0.7/14.2	
NXA	0750	6A0T02WF	750	682	500	663	872	603	793	16.0/0.8/16.8	
NXA	0820	6A0T02WF	820	745	547	725	953	659	866	16.0/0.8/16.8	CH64
NXA	0920	6A0T02WF	920	836	613	814	1070	740	972	17.8/1.0/18.4	
NXA	1030	6A0T02WF	1030	936	687	911	1197	828	1088	19.0/1.0/20.0	
NXA	1180	6A0T02WF	1180	1073	787	1044	1372	949	1247	21.0/1.1/22.1	
NXA	1300	6A0T02WF	1300	1182	867	1150	1511	1046	1374	27.0/1.4/28.4	
NXA	1500	6A0T02WF	1500	1364	1000	1327	1744	1207	1586	32.0/1.6/33.6	
NXA	1700	6A0T02WF	1700	1545	1133	1504	1976	1367	1796	38.0/1.9/39.9	

* C = power loss into coolant, A = power loss into air, T = total power loss

RATINGS AND DIMENSIONS

VACON NXB LIQUID COOLED EXTERNAL BRAKE CHOPPER, DC BUS VOLTAGE 460-800 VDC

AC drive type			Current				Braking power		Power loss c/a/T* [kW]	Chassis
			BCU rated cont. braking current I _{br} [A]	Rated min resistance @800VDC (Ω)	Rated min resistance @600VDC (Ω)	Rated max input current [Adc]	Rated cont. braking power 2*R@ 800VDC [kW]	Rated cont. braking power 2*R@ 600VDC [kW]		
NXB	0031	5A0T08WS	2*31	25.7	19.5	62	49	37	0.7/0.2/0.9	CH3
NXB	0061	5A0T08WS	2*61	13.1	9.9	122	97	73	1.3/0.3/1.5	
NXB	0087	5A0T08WS	2*87	9.2	7.0	174	138	105	1.5/0.3/1.8	
NXB	0105	5A0T08WS	2*105	7.6	5.8	210	167	127	1.8/0.3/2.1	CH4
NXB	0140	5A0T08WS	2*140	5.7	4.3	280	223	169	2.3/0.3/2.6	
NXB	0168	5A0T08WS	2*168	4.7	3.6	336	267	203	2.5/0.3/2.8	CH5
NXB	0205	5A0T08WS	2*205	3.9	3.0	410	326	248	3.0/0.4/3.4	
NXB	0261	5A0T08WS	2*261	3.1	2.3	522	415	316	4.0/0.4/4.4	
NXB	0300	5A0T08WF	2*300	2.7	2.0	600	477	363	4.5/0.4/4.9	CH61
NXB	0385	5A0T08WF	2*385	2.1	1.6	770	613	466	5.5/0.5/6.0	
NXB	0460	5A0T08WF	2*460	1.7	1.3	920	732	556	5.5/0.5/6.0	CH62
NXB	0520	5A0T08WF	2*520	1.5	1.2	1040	828	629	6.5/0.5/7.0	
NXB	0590	5A0T08WF	2*590	1.4	1.1	1180	939	714	7.5/0.6/8.1	
NXB	0650	5A0T08WF	2*650	1.2	1.0	1300	1035	786	8.5/0.6/9.1	
NXB	0730	5A0T08WF	2*730	1.1	0.9	1460	1162	833	10.0/0.7/10.7	

VACON NXB LIQUID COOLED EXTERNAL BRAKE CHOPPER, DC BUS VOLTAGE 640-1100 VDC

AC drive type			Current			Braking power		Power loss c/a/T* [kW]	Chassis	
			BCU rated cont. braking current I _{br} [A]	Rated min resistance @1100 VDC (Ω)	Rated min resistance @840 VDC (Ω)	Rated max input current [Adc]	Rated cont. braking power 2*R@1100 VDC [kW]			Rated cont. braking power 2*R@840 VDC [kW]
NXB	0170	6A0T08WF	2*170	6.5	4.9	340	372	282	4.5/0.2/4.7	CH61
NXB	0208	6A0T08WF	2*208	5.3	4	416	456	346	5.5/0.3/5.8	
NXB	0261	6A0T08WF	2*261	4.2	3.2	522	572	435	5.5/0.3/5.8	
NXB	0325	6A0T08WF	2*325	3.4	2.6	650	713	542	6.5/0.3/6.8	CH62
NXB	0385	6A0T08WF	2*385	2.9	2.2	770	845	643	7.5/0.4/7.9	
NXB	0416	6A0T08WF	2*416	2.6	2	832	913	693	8.1/0.4/8.4	
NXB	0460	6A0T08WF	2*460	2.4	1.8	920	1010	767	8.5/0.4/8.9	
NXB	0502	6A0T08WF	2*502	2.2	1.7	1004	1100	838	10.0/0.5/10.5	

NOTE: The rated currents in given ambient (+50°C) and coolant (+30°) temperatures are achieved only when the switching frequency is equal to or less than the factory default.

NOTE: Braking power: $P_{brake} = 2 \cdot U_{brake}^2 / R_{resistor}$ when 2 resistors are used

NOTE: Max input DC current: $I_{in,max} = P_{brake,max} / U_{brake}$

VACON NX OPTIONS LIQUID COOLED REGENERATIVE LINE FILTERS

LCL Filter Type	Suitability	Power loss c/a/T* [kW]	Dimensions L _{net} 1pcs, WxHxD [mm]	Dimensions L _{drive} 1pcs, (total 3pcs)WxHxD [mm]	Dimensions C 1pcs, WxHxD [mm]	Total weight [kg]
RLC-0385-6-0	CH62/690VAC: 325A & 385A	2,6/0,8/3,4	580 x 450 x 385	410 x 415 x 385	360 x 265 x 150	458
RLC-0520-6-0	CH62/500-690VAC	2,65/0,65/3,3	580 x 450 x 385	410 x 415 x 385	360 x 265 x 150	481
RLC-0750-6-0	CH62/500VAC, CH63/690VAC	3,7/1/4,7	580 x 450 x 385	410 x 450 x 385	360 x 275 x 335	508
RLC-0920-6-0	CH63/500VAC, CH64/690VAC	4,5/1,4/5,9	580 x 500 x 390	410 x 500 x 400	360 x 275 x 335	577
RLC-1180-6-0	CH63/500VAC, CH64/690VAC	6,35/1,95/8,3	585 x 545 x 385	410 x 545 x 385	350 x 290 x 460	625
RLC-1640-6-0	CH64/500-690VAC	8,2/2,8/11	585 x 645 x 385	420 x 645 x 385	350 x 290 x 460	736
RLC-2300-5-0	CH64/500VAC: 2060A & 2300A	9,5/2,9/12,4	585 x 820 x 370	410 x 820 x 380	580 x 290 x 405	896

VACON NXP LIQUID COOLED FREQUENCY CONVERTER, INTERNAL BRAKE CHOPPER UNIT, BRAKING VOLTAGE 460-800 VDC

Converter Type	Loadability	Braking capacity @ 600 VDC		Braking capacity @ 800 VDC		Chassis
	Rated min resistance [Ω]	Rated cont. braking power [kW]	BCU rated cont. braking current, I_{br} [A]	Rated cont. braking power [kW]	BCU rated cont. braking current, I_{br} [A]	
NX_460-730 5 1)	1.3	276	461	492	615	CH72
NX_1370-2300 5	1.3	276	461	492	615	CH74

1) Only 6 pulse drives

VACON NXP LIQUID COOLED FREQUENCY CONVERTER, INTERNAL BRAKE CHOPPER UNIT, BRAKING VOLTAGE 840-1100 VDC

Converter Type	Loadability	Braking capacity @ 840 VDC		Braking capacity @ 1100 VDC		Chassis
	Rated min resistance [Ω]	Rated cont. braking power [kW]	BCU rated cont. braking current, I_{br} [A]	Rated cont. braking power [kW]	BCU rated cont. braking current, I_{br} [A]	
NX_325-502 6 1)	2.8	252	300	432	392	CH72
NX_820-1700 6	2.8	252	300	432	392	CH74

1) Only 6 pulse drives

The internal brake chopper can also be used in motor application where 2...4 x Ch7x drives are used for a single motor, but in this case the DC connections of the power modules must be connected together.

VACON EXTERNAL BRAKE RESISTORS FOR LIQUID COOLED CH72 (CH74) DRIVES - IP20

Product code	Voltage range [VDC]	Maximum brake power [kW]	Maximum average power [kW] [1 pulse/2min]	Resistance [Ω]	Maximum energy [kJ] (predefined power pulse)	Dimensions W x H x D [mm]	Weight [kg]
BRW-0730-LD-5 ¹⁾	465...800VDC	637 ³⁾	13.3	1.3	1594	480 x 600 x 740	55
BRW-0730-HD-5 ²⁾	465...800VDC	637 ³⁾	34.5	1.3	4145	480 x 1020 x 740	95
BRW-0502-LD-6 ¹⁾	640...1100VDC	516 ⁴⁾	10.8	2.8	1290	480 x 760 x 530	40
BRW-0502-HD-6 ²⁾	640...1100VDC	516 ⁴⁾	28	2.8	3354	480 x 1020 x 740	85

NOTE: Thermal protection switch included

¹⁾ LD = Light Duty: 5s nominal torque braking from nominal speed reduced linearly to zero once per 120s

²⁾ HD = Heavy duty: 3s nominal torque braking at nominal speed + 7s nominal torque braking from nominal speed reduced linearly to zero once per 120s.

³⁾ at 911 VDC

⁴⁾ at 1200 VDC

Mains connection	Input voltage U _{in}	400...500 VAC; 525...690 VAC; [-10%...+10%] 465...800 VDC; 640...1100 VDC [-0%...+0%]
	Input frequency	45...66 Hz
Motor connection	Output voltage	0—U _m
	Output frequency	0...320 Hz
Control characteristics	Control method	Frequency control U/f Open loop vector control (5-150% of base speed): speed control 0.5%, dynamic 0.3%/sec, torque lin. <2%, torque rise time ~5 ms Closed loop vector control (entire speed range): speed control 0.01%, dynamic 0.2% sec, torque lin. <2%, torque rise time ~2 ms
	Switching frequency	NX_5: Up to and including NX_0061: 1...16 kHz; Factory default 10 kHz From NX_0072: 1...12 kHz; Factory default 3.6 kHz NX_6: 1...6 kHz; Factory default 1.5 kHz*
	Field weakening point	8...320 Hz
	Acceleration time	0...3000 sec
	Deceleration time	0...3000 sec
	Braking	DC brake: 30% of TN (without brake resistor), flux braking
Ambient conditions	Ambient operating temperature	-10°C (no frost)...+50°C (at I _n); The NX liquid cooled drives must be used in an heated indoor controlled environment.
	Installation temperature	0...+70°C
	Storage temperature	-40°C...+70°C; no liquid in heatsink under 0°C
	Relative humidity	5 to 96% RH, non-condensing, no dripping water
	Air quality - chemical vapours - mechanical particles*	No corrosive gases IEC 60721-3-3, unit in operation, class 3C2 IEC 60721-3-3, unit in operation, class 3S2 (no conductive dust allowed)
	Altitude	NX_5: (380...500 V): 3000 m ASL; in case network is not corner grounded NX_6: (525...690 V) max. 2000 m ASL. For further requirements, contact factory 100-% load capacity (no derating) up to 1,000 m; above 1,000 m derating of maximum ambient operating temperature by 0,5°C per each 100 m is required.
	Vibration	5...150 Hz
	EN50178/EN60068-2-6	Displacement amplitude 0.25 mm (peak) at 3...31 Hz Max acceleration amplitude 1 G at 31...150 Hz
	Shock EN50178, EN60068-2-27	UPS Drop Test (for applicable UPS weights) Storage and shipping: max 15 G, 11 ms (in package)
	Enclosure class	IP00/Open Frame standard in entire kW/HP range
EMC	Immunity	Fulfills all EMC immunity requirements
	Emissions	EMC level N, T (IT networks)
Safety		EN 50178, EN 60204-1, IEC 61800-5-1, CE, UL, CUL; (see unit nameplate for more details)
Functional safety *)	STO	EN/IEC 61800-5-2 Safe Torque Off (STO) SIL2, EN ISO 13849-1 PL"d" Category 3, EN 62061: SILCL2, IEC 61508: SIL2.
	SS1	EN /IEC 61800-5-2 Safe Stop 1 (SS1) SIL2, EN ISO 13849-1 PL"d" Category 3, EN /IEC62061: SILCL2, IEC 61508: SIL2.
	ATEX Thermistor input	94/9/EC, CE 0537 Ex 11 (2) GD
Approvals	Type tested	SGS Fimko CE, UL
	Type approval	DNV, BV, Lloyd's Register (other marine societies delivery based approvals)
	Approvals our partners have	Ex, SIRA
Liquid cooling	Allowed cooling agents	Drinking water Water-glycol mixture
	Temperature of cooling agent	0...35°C (I _n)(input); 35...55°C, please see manual for further details Temperature rise during circulation max. 5°C No condensation allowed
	System max. working pressure	6 bar/ 40 bar peak
	Pressure loss (at nominal flow)	Varies according to size, please see manual for further details
Protections		Overvoltage, undervoltage, earth fault, mains supervision, motor phase supervision, overcurrent, unit overtemperature, motor overload, motor stall, motor underload, short-circuit of +24 V and +10 V reference voltages.

* with OPT-AF board

WE ARE DRIVES



VACON[®] 8000 SOLAR



A DRIVING FORCE IN RENEWABLE ENERGY

Vacon was founded in Vaasa, Finland in 1993. It has a long history of producing high-quality inverters, power converters and AC drives for demanding renewable energy and industrial applications and operating environments. We have a solid foundation to lean on and we thrive on actively driving the industry forward.

RELIABLE PERFORMANCE

To date, over 7000 MW of renewable peak power capacity has been enabled by Vacon inverters. To put these numbers into perspective, a typical nuclear power plant can produce up to 1000 MW of capacity. And with an R&D team dedicated solely to the development of new solar energy applications, we continue to strengthen the position of renewable energy as one of the cornerstones of our company strategy.

STRONG GLOBAL PRESENCE

Vacon is an established and international company with production on three different continents. A large and continuous flow of parts improves the availability of our products and solutions. We have a global service network: Vacon has offices in 27 countries and extensive partner network in nearly 90 locations.

In accordance with our long history of producing reliable solutions, all the VACON® 8000 SOLAR products are extensively tested before delivery.

HARNESSING THE SUN

Vacon's offering for the solar energy industry is not just limited to our inverter products. Based on our long experience in serving our customers in the renewable energy field, as well as other demanding industries, we can offer you the whole package from products to maintenance services and support for planning and commissioning.

Solar inverters, such as the VACON® 8000 SOLAR, are a vital part of the configuration between solar panels and the general grid. The function of an inverter is simply to convert the captured photovoltaic power into AC, and feed it into the grid.

The VACON 8000 SOLAR covers all the needs of the commercial, industrial and utility sectors. Our products have been designed with ease in mind. They are easy to install, use and maintain. The modular set-up and additional tools give you an enjoyable user experience with numerous benefits.

We take care of all your solar inverter needs. Our wide power range of solar inverters is supported by a variety of string connection boxes as well as medium voltage outdoor stations. We also understand how essential it is to be able to provide first-class commissioning- and maintenance services at any location where you decide to install your solar power plant.

VACON® 8000 SOLAR WITH MULTIMASTER: KEEPS YOUR SUN SHINING EVEN DURING SERVICE

EASE AND RELIABILITY THROUGH MODULARITY

The Solar Multimaster is a unique concept that improves efficiency, reliability and functionality in all large-scale applications. The concept allows a series of one to twelve separate inverter units to be connected together in sequence. This means that only the optimal needed number of inverter modules is powered up for minimal power loss. By rotating the inverters in use we can ensure reduced and equal run-time, thereby extending the entire set-ups overall lifetime.

The entire set-up is centrally controlled via the touch screen on the control unit. This modular approach creates numerous advantages compared to conventional single inverter set-ups. In addition to allowing for optimisation according to sunlight, the modularity allows for repairs and maintenance to be carried out without complete shutdowns. The charging fuse disconnectors allow single units to be safely connected and disconnected while the set-up is up and running.

BY ROTATING INVERTER UNITS IN USE WE ENSURE EQUAL USAGE AND EXTEND THEIR LIFETIME

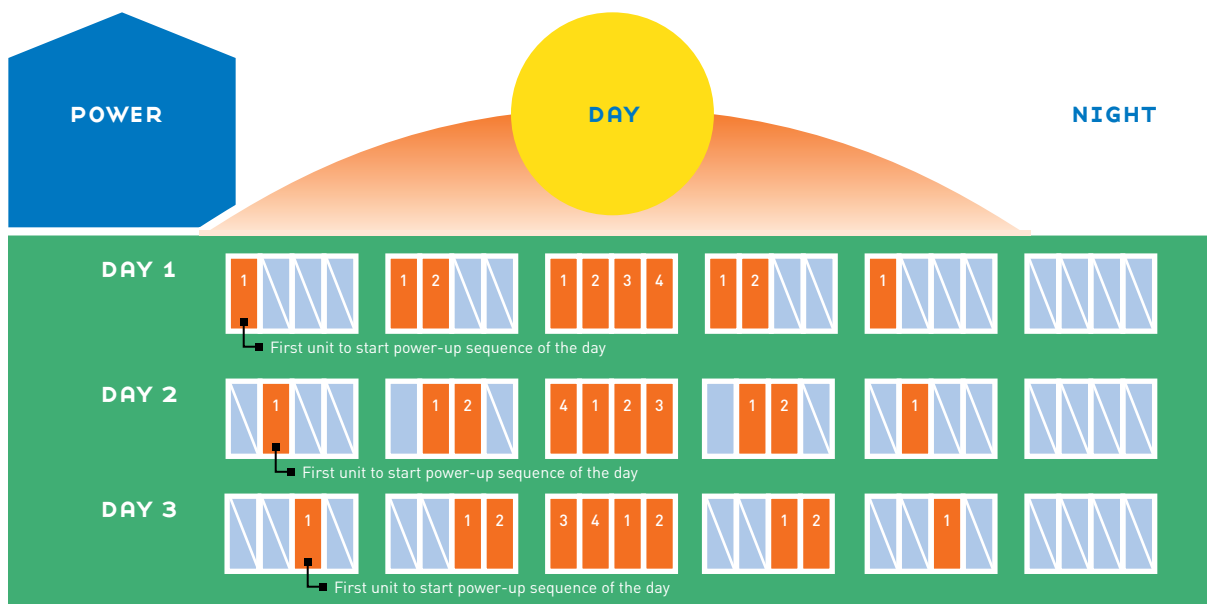

VACON® 8000 SOLAR MULTIMASTER BENEFITS

40% LOWER WEAR AND TEAR OF EACH INVERTER MODULE

The 1 MW VACON 8000 SOLAR Multimaster consists of 5 parallel inverter modules that are started up only when the available power from solar panels require it. In practice, during mornings, evenings and cloudy days only some of the units are active. This reduces the running hours of each module by 40% on a typical installation site. Reduced running hours will result in a longer lifetime and a lower failure rate.

BETTER AVAILABILITY THROUGH REDUNDANCY

If one inverter module in the 1 MW VACON 8000 SOLAR is not operating due to maintenance work or unit failure, the loss of production is only 4%. Typically only 4% of the accumulated energy per year is generated with peak capacity provided by the 5th module. This means that with the VACON 8000 SOLAR you will reach 99% availability even if one of the modules is down for 3 months. The modules are installed in individual cabinet sections. In case of a failure in one of the cabinets, the other modules are protected and the failure is isolated into only one section. The amount of spare parts needed to guarantee fast service is also smaller and less expensive due to the lower power per module.

SIMPLE TRANSFORMER DESIGN

Vacon has patented a switching algorithm that minimizes the circulating currents between inverters and the transformer. This allows you to use a transformer with single secondary winding when connected to the VACON 8000 SOLAR with Multimaster.

OPERATIONAL HOURS

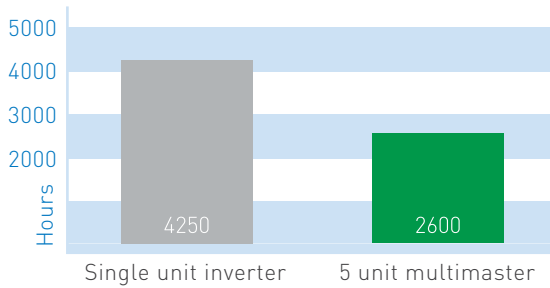

ENERGY LOSS COMPARISON

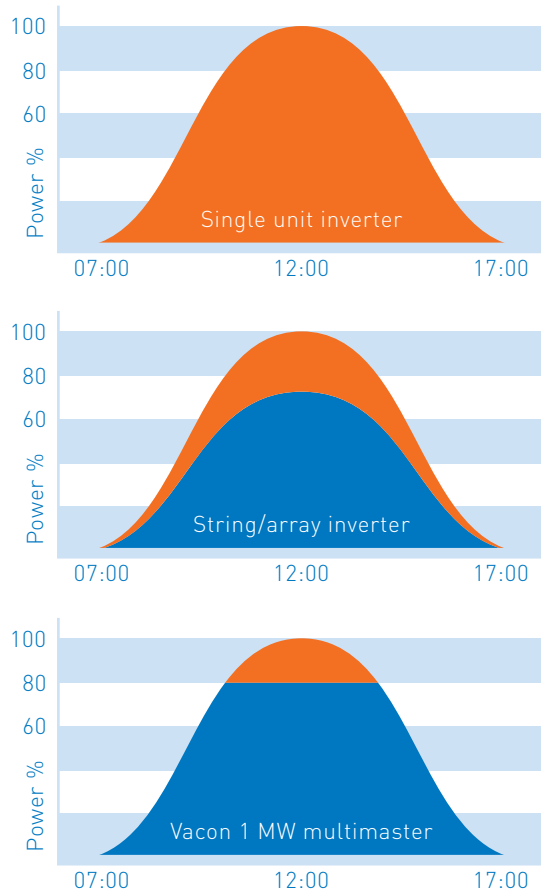



VACON® 8000 SOLAR INVERTER MODULES

In addition to full solar inverter solutions, Vacon also offers a range of key individual solar components to our customers. All our components come with the same benefits as they do in comprehensive Vacon solar solutions i.e. excellent reliability, efficiency, and full grid code support.

SUNSHINE INTO POWER

Inverting solar energy has one major obstacle in its way – to successfully harness power from a PV source into the grid, it is essential that the voltage and frequency is constantly controlled. The amount of energy a photovoltaic system produces is dependent on variables such as cloud cover, the angle of the sun and ambient temperature. We take this into account by decoupling the voltage and current harvested from the Sun to those fed into the grid. This means the PV array can remain at its optimum operating point at any given time and, with the help of state-of-the-art power electronics, voltage and frequency being fed into the grid can be controlled according to grid requirements.

SOLAR INVERTER MODULE

Solar inverter modules utilize close-looped control to feed energy into the grid. Combining these two components with a filter module produces a comprehensive, readily connectable Vacon solar inverter system, with the option of expansion according to the customer's needs. Connectivity to communication networks such as Modbus and Profibus allows the user to constantly monitor and maintain the system to ensure they get the most out of their Vacon Solar module solution. In addition, there is an IEC61131-3 compatible software tool available for the customer's specific application requirements.

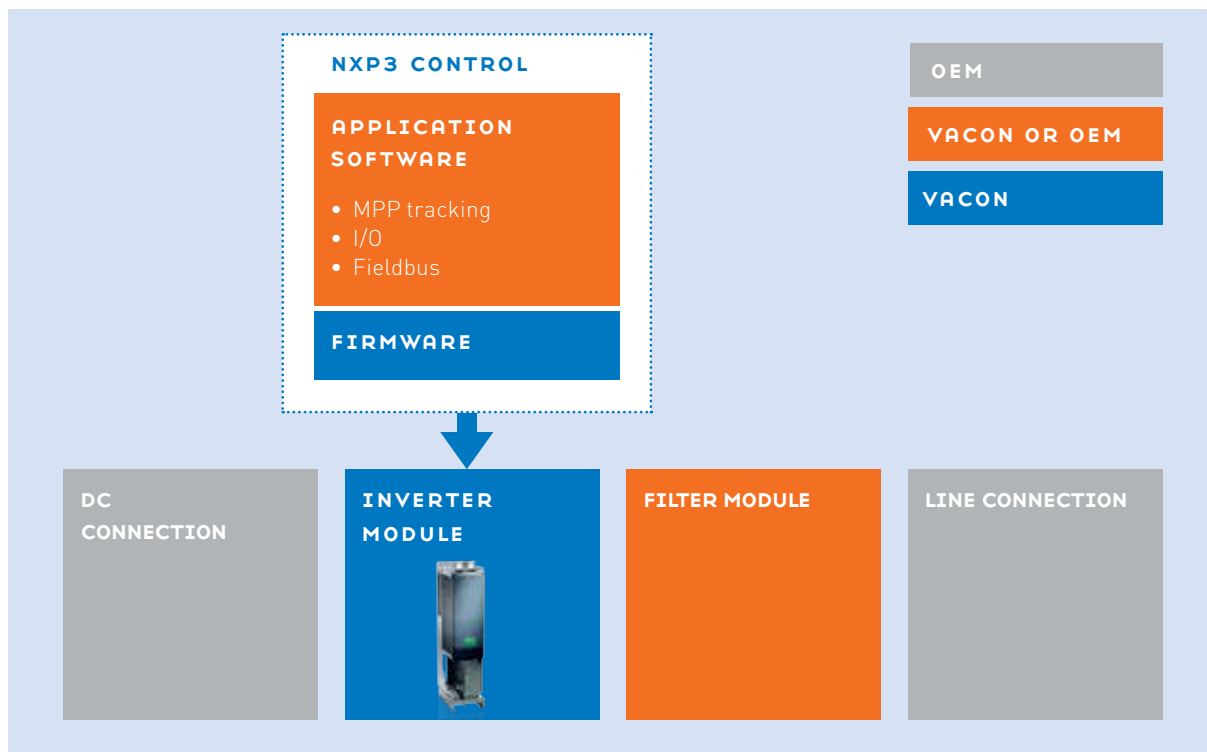

Topology example of a PV inverter system for photovoltaic systems based on Vacon modules for solar inverters. Customers have an option to build their own application software and select the filter, although Vacon can offer both for maximum performance and optimization. Engineering support for solution tailoring is also available.

Module	Device frame	Power kW	Max. current DC A	Current AC A	Min. voltage DC V	Voltage AC V
SXA0145	F110	145	354	299	410	280
SXA0186	F110	186	454	324	410	280
SXA0200	F110	200	488	412	410	280

HIGH-PERFORMANCE CONTROL

Vacon has a high-performance NXP3 control that is perfect for solar applications. The micro controller provides exceptional processing and calculating power, while low harmonic control is available in open- and closed-loop control modes. The Vacon control features built-in PLC functionality without the need for any additional hardware and all customer- specific functionality can be integrated to cut costs and improve performance. The same control is used in all Vacon solar modules, allowing the maximum utilization of control features over a wide power and voltage range.

VOLTAGE MEASUREMENT

To ensure that voltage is under control, it has to be measured constantly. By sensing the amplitude, phase position and phase angle of the grid voltage, the inverter synchronizes to transmit as much energy as is required at any given time. Vacon has designed a board which enables superior performance during demanding grid conditions like in low voltage ride-through situations.

WE ARE DRIVES



VACON[®] PC TOOLS

OPTIMIZE YOUR DRIVE YOUR WAY WITH VACON SOFTWARE TOOLS

COMMISSIONING MADE EASY WITH VACON® LIVE

VACON Live is a free PC tool which communicates directly with the VACON 100 drive via Ethernet or through a USB-to-RS485 interface. This makes for particularly easy installation, commissioning and maintenance.

The drive, as well as process-related values can be graphically monitored in real time. Parameters can be edited, saved for back-up and compared with defaults or a back-up file. You only need to send one service info file to your service provider for quick support. A service info file contains parameters and other data such as history of faults and alarms, as well as drive hardware and software details. Drive software and language support files can be loaded to the drive using VACON Loader software, which is included in the VACON Live tool.

ADDITIONAL FEATURES

- Export service info option which includes parameters, fault history, drive information, firmware information and more
- Create User Groups for common parameters across multiple size drives
- Compare drive parameters to default settings or a saved set of parameters
- Connect to multiple drives via Ethernet
- Name individual drives for easy identification
- Vacon Live automatically searches for PC tool updates

VACON LOADER

- Free Firmware and Software loading application bundled with Vacon Live
- Load firmware updates containing fixes or new features to the Vacon 10 and Vacon 100 HVAC
- Load special Vacon applications to the Vacon 10 and Vacon 100 HVAC
- Load custom application software to the Vacon 10 and Vacon 100 HVAC
- Update functions of the Vacon Micro Communication Adapter (MCA) for Vacon 10

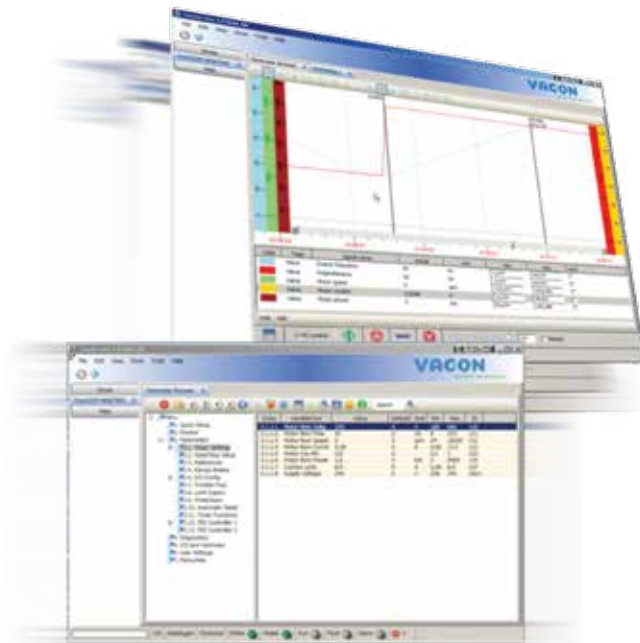

VACON®
PC TOOLS

KEY BENEFITS

Economical

- Save on operating & maintenance costs
- Reduce downtime
- Optimize energy savings
- Minimize costs due to harmonic disruptions

Easy

- Simple to configure and use
- Customize on field with Block Programming
- Easy commissioning & maintenance
- Meet harmonic standards the easy way

DRIVE CUSTOMIZER

Available in VACON 100,
VACON 100 FLOW and VACON 100 X

- User interface for the built-in function block programming
- Easy on site drive customization with VACON Live
- 10 Programmable Function Blocks
- Library of 39 different function blocks (AND, OR, ADD, Fault_Status, etc.)
- Function blocks are executed at 10ms program cycle
- Program is stored in the drive parameters and can be copied to other drives with parameter file.

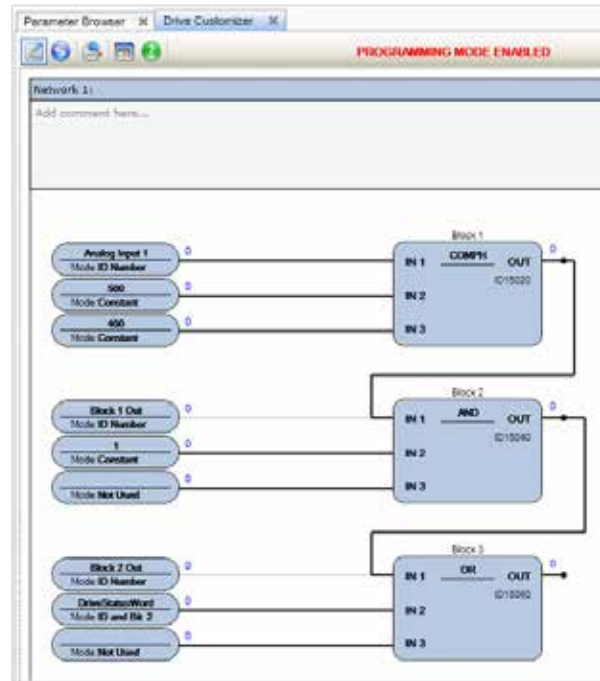

VACON® SAVE

Energy costs account for the majority of your installation's lifetime costs. With VACON Save you can calculate your energy savings in kWh when you implement a VACON 100 to the pumps and fans in your processes. While displaying savings in your own currency, it will also estimate the short payback time of your VACON 100 purchases as well as the reductions in carbon dioxide emissions in your country.

REQUIREMENTS

VACON 100 Family, VACON 20 Cold Plate and VACON 20 X require CAB-USB/485 to interface with the VACON Live PC Tool.

VACON 10 and VACON 20 require VACON-ADP-MCAA-KIT to interface with the VACON Live PC Tool.

Alternately, VACON 20 can use VACON-ADP-PASSIVE and CAB-USB/485 options in combination to interface with the VACON Live PC Tool.

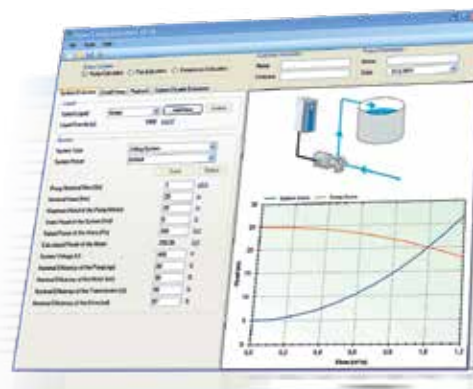

NCDRIVE FOR THE VACON NX FAMILY

The NCDrive is a versatile commissioning and maintenance tool for Vacon. The tool provides four main windows for different purposes: parameter, monitor, operating and diagnostic window. Moreover, there is a data logger and trend recorder for the Vacon NXP drives.

PARAMETER WINDOW

- Parameter values are visible with the parameter name, default value and its minimum and maximum limits
- Parameters can be uploaded or downloaded to/from Vacon AC drives
- Parameters can be edited online or offline. In the online mode, the changes take place immediately in Vacon AC drives
- Parameters can be saved on a computer hard disk in text or Excel format for back-up purposes
- The parameters in Vacon AC drives or in a file can be compared with the parameters in any other parameter file in the computer

MONITOR WINDOW

- Monitoring of eight signals in graphical format on the same time axis
- Minimum sample time of 50 ms with RS232 and of 1 ms with CAN communication
- Minimum and maximum scaling can be modified any time
- Graphical screen can be saved onto the hard disk. It can also be exported in BMP or Excel format.
- The monitoring data can be triggered on condition to debug specific problems.

DIAGNOSTIC WINDOW

- Active faults in Vacon AC drives with associated signal values at the time of fault such as frequency, current, and more
- Fault history with associated signal values at the time of each fault. The last 30 faults can be viewed.

OPERATING WINDOW

- Vacon AC drives can be controlled from the NCDrive and motor can be run as required
- Run, Stop, Fault reset, Coast stop, Direction reverse through simple graphical buttons
- Speed/frequency reference can be set directly, or by using the scroll bar
- Status indication for ready, running, fault, alarm, active control place and datalogger status in the task bar

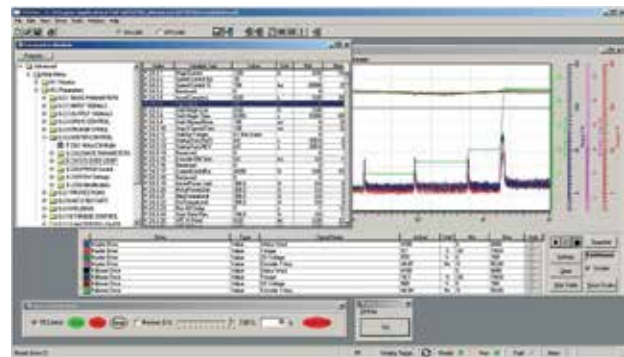

SPECIAL FEATURES FOR VACON NXP

DATALOGGER WINDOW

- Data logged in the drive for eight signals with a minimum sample time of 1 ms
- NCDrive can, for instance, be used to set the signals, trigger condition, and so forth
- The triggered data saved in the drive can be uploaded in graphical form, and can also be exported as BMP or Excel

TREND RECORDER WINDOW

- The data can be saved continuously for longer periods, typically for hours, onto the hard disk
- The saved trend data can be opened any time in graphical format and scrolled through the time axis
- Available only for the Vacon NXP via the CAN bus interface

OTHER FEATURES

- Real-time clock setting in the Vacon NXP
- Parameter, monitor, diagnostic, data logger and trend data can be printed
- Application file database can be generated from the drive
- Firmware and application variables can be monitored for advanced debugging
- Service info keeps the complete information of the drive including hardware, software details, hour counters, parameter settings, and a fault logger

NLOAD, LOADING TOOL

The NLoad is an easy-to-use service tool for downloading applications, language packages, option board software, and system software to Vacon AC drives. The graphical user interface provides an easy point-and-click selection of applications to be downloaded. After a successful download, the drive will be reset, and the custom application is ready to use.

You can download multiple applications to Vacon AC drives and activate the one that is required at the given moment. All hardware, software and option board details are readily available for viewing via the NLoad. The NCDrive uses a simple RS232 communication cable (RS232-1,5M) between the PC and Vacon AC drive. A fast and multidrop CAN communication can be used with the Vacon NXP. The CAN bus cable can be connected to a PC using a USB-to-CAN interface or a CAN-to-Ethernet interface.

SPECIAL VACON NX FAMILY APPLICATIONS

The Vacon NX Family is built on an open application architecture which allows additional functions and capabilities to be added as well as allowing default settings and limits of parameters to be adjusted. Vacon also makes available to the public many special applications to provide solutions for common industries.

VACON NXS APPLICATIONS

ASFIF08 Standard Lift Application

The Lift Application can be used with modern Lift systems. There are functions included that are required to achieve a smooth ride in the lift car.

In the application, constant speeds are presented in [m/s] and also in [Hz], acceleration and deceleration are presented in [m/s²] and jerks are presented in [ms]. Mechanical brake control logic is designed to achieve smooth departures from and landings to floor level. The brake can be set in various ways to meet the different requirements of lift motors and lift control logic. The used hardware can be any Vacon NXS or NXP frequency converter.

ASFIF09 Multi-Master PFC (WATER PACKAGE)

The application is designed to achieve an even wear of the pumps connected to the motors/drives by regularly changing the regulating order of the drives. The application supports max. 3 devices to work in parallel. One drive is leading and regulating (PID) while the others are either stand-by or running at the speed producing the nominal flow in the system.

The autochange of the regulating drive/pump can be performed during run without any notice in the pressure in the pipes. This means also that each drive can become the regulating drive of the system.

Due to the fact that all 3 devices are controlled by its own drive, the system will be controlled even if one or two of the drives are tripped.

VACON NXP APPLICATIONS

APFIF08 NXP Lift application

Same function as in APFIF08 Standard lift application but with PM motor support added.

APFIF09 Marine

Specially designed for Marine segment, but can be used in any demanding application.

Additional functions (compared MP application):

- Most NXP performance features are available
- Advanced power limit functions can be utilized
- Power limits by DI or from fieldbus for both Motoring and Generating side.
- Master Follower function for steering propeller and double winding motors
- Different Torque limits for motoring and generating side
- Cooling monitor input from heat exchange unit
- Brake monitoring input and actual current monitor for immediate brake close.
- Separate speed control tuning for different speeds and loads
- Inching function two different reference
- Possibility to connect FB Process data's to any parameter and some monitoring values
- Identification parameter can be adjust manually
- Analogue input 3 and 4 can control any parameter by ID number
- Support for four analogue outputs

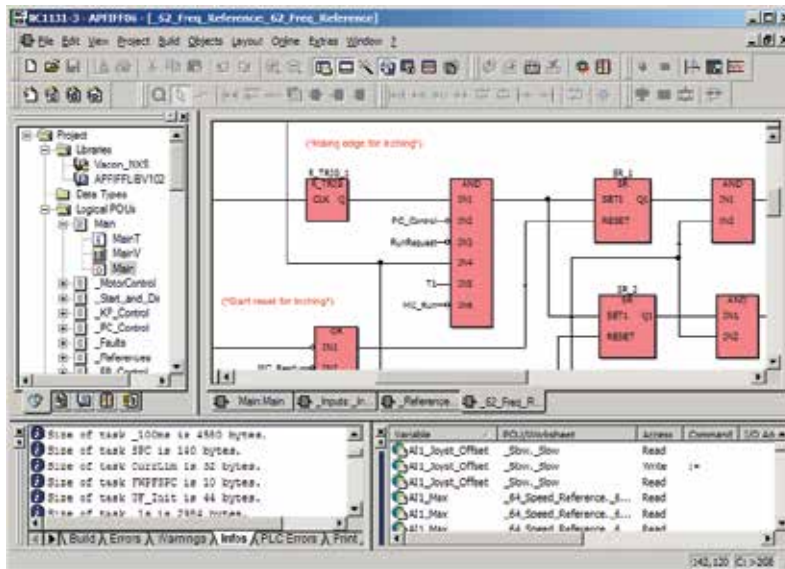

The Vacon NC61131-3 Application Programming Suite consists of tools that offer all that is necessary for making professional and efficient applications. This suite enables you to adapt Vacon AC drives to your application-specific requirements.

The Vacon NC61131-3 Application Programming Suite supports many programming languages which are based on the IEC61131-3 standard. An entire application can be done in a few easy steps by using a specific tool for each programming phase. The Application Programming Suite offers a graphical programming environment for the functional design of an application.

NC61131-3, BLOCK PROGRAMMING TOOL

The NC61131-3 is a block programming tool to make a graphical presentation of the application. The application is made with the user-selected programming language (Function Block Diagram, Structured Text, Sequential Function Chart, or Ladder Diagram). The user selects the necessary functions and function blocks from the library to the worksheet and wires them together in order to define the desired functionality for the application.

The tool incorporates a wide range of IEC features. The PLC type of logic can be programmed with Boolean functions, timers, counters, comparators and flip-flops. In addition, frequency-converter-related functions can be created by using scaling, ramp control, PI(D) control, and more can be added. These features ensure that the drive control and the PLC control can be combined, and external equipment (e.g. small PLCs with control logic) are no longer necessary.

The NC61131-3 also has a new online debugging feature. It displays all the internal variables of the application with their status.

NCDEF, DEFINITION TOOL

The NCDef is a tool to make local control panel definitions for an application. The NCDef is a link between the logic program and keypad layout. This tool is used for creating parameters, variables, references and special buttons for the AC drive. If you want to show text instead of numerical values for a parameter, the tool offers an option to define unique value-to-text conversion pairs.

The NCDef also assists in customizing the menu groups for easy and clear parameter and variable reading via a local control panel. The menu groups can be modified, deleted or added as required.

PURCHASING NC61131-3

A License Fee is required to obtain a copy of NC61131-2 for VACON NXS and VACON NXP. Training is also required and is not included in the price of the NC61131-3 License Fee. Please contact your local Vacon Sales Representative for more information.

VACON[®] AC DRIVES TYPE CODE KEYS

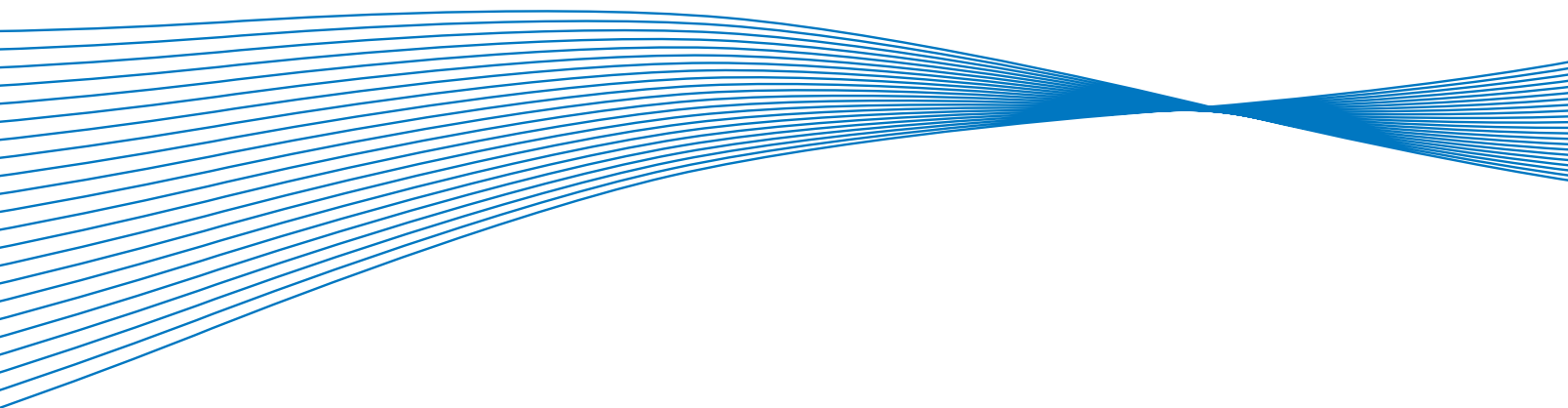

COMPACT AC DRIVES

VACON 10

VACON0010 - 3L - 0006 - 4 - R02 + OPTION CODES

0010	Product Range VACON 10
3L	Input/Function 1L = Single Phase Input (3 Phase Output) 3L = Three Phase Input
0006	Drive Rating in Amps Ex: 0006 = 6A
4	Supply Voltage 1 = 115V 2 = 208-240V 4 = 380-480V 7 = 575V
R02	Regional Modifier Includes: +EMC4 = EMC Level C4 +LS60 = 60Hz NEMA Configuration +QPES = PE Plate Kit
+	
OPTION CODES	See page 16 for list of all VACON 10 +Option Codes

VACON 20

VACON0020 - 3L - 0006 - 4 - R02 + OPTION CODES

0020	Product Range VACON 20
3L	Input/Function 1L = Single Phase Input (3 Phase Output) 3L = Three Phase Input
0006	Drive Rating in Amps Ex: 0006 = 6A
4	Supply Voltage 1 = 115V 2 = 208-240V 4 = 380-480V 7 = 575V
R02	Regional Modifier Includes: +EMC4 = EMC Level C4 +LS60 = 60Hz NEMA Configuration +QPES = PE Plate Kit
+	
OPTION CODES	See page 22 for list of all VACON 10 +Option Codes

VACON 20 COLD PLATE

VACON0020 - 3L - 0006 - 4 - CP + OPTION CODES

0020	Product Range VACON 20
3L	Input/Function 1L = Single Phase Input (3 Phase Output) 3L = Three Phase Input
0006	Drive Rating in Amps Ex: 0006 = 6A
4	Supply Voltage 2 = 208-240V 4 = 380-480V
CP	Product Type Includes: STO Integrated
R02	Regional Modifier includes: +LS60 = 60Hz NEMA Configuration +EMC4 = EMC Level C4
+	
OPTION CODES	See Page 28 for a list of all VACON 20 Cold Plate + Option Codes

VACON 20 X

VACON0020 - 3L - 0006 - 4 - X - R02 + OPTION CODES

0020	Product Range VACON 20
3L	Input/Function 1L = Single Phase Input (3 Phase Output) 3L = Three Phase Input
0006	Drive Rating in Amps Ex: 0006 = 6A
4	Supply Voltage 2 = 208-240 V 4 = 380-480 V
X	IP66/Type 4X drive STO integrated Brake chopper integrated
R02	Regional Modifier includes: +LS60 = 60Hz NEMA Configuration +EMC4 = EMC4 Level C4 +HMTX = Text Keypad IP66 +QGLC = Metal Conduit Adapters
+	
OPTION CODES	See page 35 for list of all VACON 20 X +Option Codes

VACON 100

VACON0100 - 3L - 0006 - 5 - R02 + OPTION CODES

- 0100** — Product Range
VACON 100
- 3L** — Input/Function
3L = Three Phase Input
- 0006** — Drive Rating in Amps
Ex: 0006 = 6A
- 5** — Supply Voltage
2 = 208-240V
5 = 380-500V
- R02** — Regional Modifier Includes:
IP21/UL Type 1
+EMC4 = EMC Level C4
+LS60 = 60Hz NEMA Configuration
+FL03 = Language Pack Including:
- English, French, Spanish
- Brazilian Portugese, Italian, Dutch
+QGLC = Imperial Conduit Openings
+FBIE = ProfiNet and Ethernet/IP
- +**
- OPTION CODES** — See Page 43 for a list of all VACON 100 + Option Codes

VACON 100 FLOW

VACON0100 - 3L - 0006 - 5 - FLOW - R02 + OPTION CODES

- 0100** — Product Range
VACON 100
- 3L** — Input/Function
3L = Three Phase Input
- 0006** — Drive Rating in Amps
Ex: 0006 = 6A
- 5** — Supply Voltage
2 = 208-240V
5 = 380-500V
- FLOW** — Product Type
VACON 100 FLOW
- R02** — Regional Modifier Includes:
IP21/UL Type 1
+EMC4 = EMC Level C4
+LS60 = 60Hz NEMA Configuration
+FL03 = Language Pack Including:
- English, French, Spanish
- Brazilian Portugese, Italian, Dutch
+QGLC = Imperial Conduit Openings
+FBIE = ProfiNet and Ethernet/IP
- +**
- OPTION CODES** — See Page 54 for a list of all VACON 100 FLOW + Option Codes

VACON 100 HVAC

VACON0100 - 3L - 0006 - 4 - HVAC - R02 + OPTION CODES

- 0100** — Product Range
VACON 100
- 3L** — Input/Function
3L = Three Phase Input
- 0006** — Drive Rating in Amps
Ex: 0006 = 6A
- 5** — Supply Voltage
2 = 208-240V
4 = 380-480V
- HVAC** — Product Type
VACON 100 HVAC
- R02** — Regional Modifier Includes:
IP21/UL Type 1
+EMC4 = EMC Level C4
+LS60 = 60Hz NEMA Configuration
+FL03 = Language Pack Including:
- English, French, Spanish
- Brazilian Portugese, Italian, Dutch
+QGLC = Imperial Conduit Openings
- +**
- OPTION CODES** — See Page 63 for a list of all VACON 100 HVAC + Option Codes

VACON 100 X

VACON0100 - 3L - 0006 - 5 - X - R02 + OPTION CODES

- 0100** — Product Range
VACON 100
- 3L** — Input/Function
3L = Three Phase Input
- 0006** — Drive Rating in Amps
Ex: 0006 = 6A
- 5** — Supply Voltage
2 = 208-240V
5 = 380-500V
- X** — IP66/Type 4X
EMC level C2
STO integrated
Brake chopper integrated
- R02** — Regional Modifier Includes:
IP21/UL Type 1
+EMC4 = EMC Level C4
+LS60 = 60Hz NEMA Configuration
+FL03 = Language Pack Including:
- English, French, Spanish
- Brazilian Portugese, Italian, Dutch
+QGLC = Imperial Conduit Openings
+FBIE = ProfiNet and Ethernet/IP
+HMGR = Graphical Keypad
- +**
- OPTION CODES** — See page 69 for list of all VACON 100 X +Option Codes

VACON X SERIES AND VACON NXS

VACON X4

VACON X4 C 4 0050 C

- X4** — **Product Range**
VACON X4
- C** — **Configuration**
C = 60Hz, HP, Imperial Conduit Entry
K = 50Hz, kW, Metric Conduit Entry
- 4** — **Supply Voltage**
1S = 115V Single Phase Input
2S = 200-230V Single Phase Input
2 = 200-230V Three Phase Input
4 = 380-460V Three Phase Input
5 = 575V Three Phase Input
- 0050** — **Horsepower (Low Overload)**
Ex: 0050 = 5 HP
- C** — **Enclosure Rating**
C = UL Type 4X Indoor/Outdoor
D = UL Type 12 Indoor Only
K = UL Type 3R Indoor/Outdoor

VACON X5

VACON X5 C 4 0050 C 09

- X5** — **Product Range**
VACON X5
- C** — **Configuration**
C = 60Hz, HP, Imperial Conduit Entry
K = 50Hz, kW, Metric Conduit Entry
- 4** — **Supply Voltage**
1S = 115V Single Phase Input
2S = 200-230V Single Phase Input
2 = 200-230V Three Phase Input
4 = 380-460V Three Phase Input
5 = 575V Three Phase Input
- 0050** — **Horsepower (Low Overload)**
Ex: 0050 = 5 HP
- C** — **Enclosure Rating**
C = UL Type 4X Indoor/Outdoor
D = UL Type 12 Indoor Only
K = UL Type 3R Indoor/Outdoor
- 09** — **Option Card Support**
09 = No Option Card Support

VACON NXS

NXS 0003 5 - A 2 H 1 S S S - A1 A2 00 00 00

- NXS** — **Product Range**
VACON NXS
- 0003** — **Current Rating (Low Overload)**
Ex: 0003 = 3A
- 5** — **Supply Voltage**
2 = 208-240V Three Phase
5 = 380-500V Three Phase
6 = 525-690V Three Phase
- A** — **Keypad Option**
A = Standard Alpha-Numeric Display
B = No Keypad
F = Dummy Keypad (No interface)
G = Graphical Display (Cyrillic Languages)
- 2** — **Enclosure Class**
2 = IP21/UL Type 1
5 = IP54/UL Type 12
T = Flange Mounting Factory Installed
- H** — **EMC Emission Levels**
C = category C1, EN 61800-3
H = category C2, EN 61800-3
L = category C3, EN 61800-3
T = IT networks (EN61800-3)
- 1** — **Brake Chopper**
0 = No Brake Chopper
1 = Integrated Brake Chopper
2 = Integrated Brake Chopper + Brake Resistor
- S** — **Electrical Modifications**
S = Standard 6-Pulse w/ Integrated Choke
B = DC Bus Connection
- S** — **Mechanical Modifications**
S = Standard Air Cooled Drive
G = Standard Air Cooled Drive, No Conduit Box*
- S** — **Card Modifications**
S = Standard Connection / Not Varnished
V = Standard Connection / Varnished Boards
- A1** — **Option Boards (Installed)**
Each Two-digit code represents a card slot in order from left to right, Slot A, Slot B, Slot C, Slot D, Slot E
- A2**
- 00**
- 00**
- 00**

VACON X5 HAZLO

VACON X5 C 4 0050 X

- X5** — **Product Range**
VACON X5
- C** — **Configuration**
C = 60Hz, HP, Imperial Conduit Entry
K = 50Hz, kW, Metric Conduit Entry
- 4** — **Supply Voltage**
4 = 380-460V Three Phase Input
5 = 575V Three Phase Input
- 0500** — **Horsepower (Low Overload)**
Ex: 0500 = 50 HP
- X** — **Enclosure Rating**
X = UL Type 4X Indoor/
Outdoor, Safety Yellow
Y = UL Type 4X Indoor/Outdoor,
Stainless Steel Enclosure

VACON NXP

NXP 0000 5 - A 0 N 1 S W V - A1 A2 00 00 C3

- NXP** ■ **Product Range**
NXP = Frequency converter or inverter unit
NXA = Active front-end unit
NXB = Brake-chopper unit
- 0000** ■ **Nominal current** (low overload)
0007 = 7 A, 0022 = 22 A, 0205 = 205 A etc.
- 5** ■ **Nominal mains voltage**
2 = 208-240 V
5 = 380-500 V
6 = 525-690 V
- A** ■ **Control keypad**
A = standard alpha-numeric B = no local control keypad
F = dummy panel
- 0** ■ **Enclosure class**
0 = IP00
- N** ■ **EMC emission levels**
C = category C1, EN 61800-3
H = category C2, EN 61800-3
L = category C3, EN 61800-3
T = IT networks (EN61800-3)
N = enclosure required (FR10-FR14)
- 1** ■ **Brake chopper**
0 = no brake chopper
1 = integrated brake chopper (CH3, CH72 (6-pulse) & CH74 only)
- S** ■ **Hardware modifications: supply**
I = Inverter unit; DC-supply,
2 = Active front-end unit
S = Standard supply; 6-pulse connection with chokes
N = Standard supply; 6-pulse connection without chokes
T = 12-pulse connection with chokes
U = 12-pulse connection without chokes
- W** ■ **Hardware modifications: cooling**
W = Liquid-cooled module with aluminium heatsink
P = Liquid-cooled module with nickel-coated aluminium heatsink
- V** ■ **Hardware modifications: boards**
F = Fiber connection, standard (from CH61)
G = Fiber connection, varnished (from CH61)
S = Direct connection, standard
V = Direct connection, varnished

If OPT-AF option board is used
N = IP54 control box, fiber connection, standard boards, (from CH61)
O = IP54 control box, fiber connection, varnished boards, (from CH61)
- A1** ■ **Option boards:**
Each Two-digit code represents a card slot in order from left to right, Slot A, Slot B, Slot C, Slot D, Slot E
- A2**
- 00**
- 00**
- C3**

VACON NXC

NXC 0520 5 - A 2 L 0 S S F - A1 A2 00 00 00 + IFD

- NXC** ■ **Product Range**
NXP = wall-mounted / standalone / module
NXC = cabinet
- 0520** ■ **Nominal current voltage**
0520 = 520 A
- 5** ■ **Nominal mains voltage**
2 = 208-240 V
5 = 380-500 V
6 = 525-690 V
- A** ■ **Control keypad**
A = standard alphanumeric B = no local keypad
F = dummy keypad G = graphic display
- 2** ■ **Enclosure class**
5 = IP54, FR4...7
2 = IP21, FR4...7
0 = IP00, FR8, FR9...14
- L** ■ **EMC emission levels**
C = category C1, EN 61800-3
H = category C2, EN 61800-3
L = category C3, EN 61800-3
T = IT networks (EN61800-3)
N = enclosure required (FR10-FR14)
- 0** ■ **Brake chopper**
0 = no brake chopper
1 = integrated brake chopper
- S** ■ **Supply**
S = 6-pulse
T = 12-pulse
O = 6-pulse + load switch (standalone)
R = Low-harmonic
- S** ■ **Cooling**
S = standard air-cooled
T = through-hole mounting FR4-FR9
- F** ■ **Control**
S = standard FR4-FR8
F = standard FR9 and NXC
A = standard NXP FR10-FR12
N = standard IP00 »
FR10 & NXC with IP54 control unit enclosure
V = as S, but varnished
G = as F, but varnished boards
B = as A, but varnished boards
O = as N, but varnished boards
- A1** ■ **Option boards:**
Each Two-digit code represents a card slot in order from left to right, Slot A, Slot B, Slot C, Slot D, Slot E
- A2**
- 00**
- 00**
- 00**
- +**
- IFD** ■ See Page 110 for a list of all VACON NXC Options

VACON NXP IPOO MODULES

VACON NXN – NON-REGENERATIVE FRONT-END (NFE)

NX N 0650 6 - X 0 T 0 S S V - 00 00 00 00 00

NX	Product generation
N	Module type N = NFE Non-Regenerative Front-End
0650	Nominal current (low overload) eg. 0650 = 650 A only
6	Nominal supply voltage 6 = 380-690 VAC / 513-931 VDC
X	Control keypad X = standard (alpha numeric)
0	Enclosure class 0 = IP00, F19
T	EMC emission level T = IT networks (EN61800-3)
0	Internal brake chopper 0 = N/A (no brake chopper)
S	Delivery include N = NFE module S = NFE module + AC choke
S	S = Standard air cooled drive U = Standard air cooled power unit - external supply for main fan
V	Hardware modifications; module type - S Boards V = Direct connection, varnished boards
00	Option boards; each slot is represented by two characters: No option board possible
00	
00	
00	
00	

VACON NXA – ACTIVE FRONT-END (AFE)

NX A 0261 - V A 0 T 0 2 S F - A1 A2 00 00 00

NX	Product generation
A	Module type A = AFE Active Front-End
AAAA	Nominal current (low overload) eg. 0261 = 261 A, 1030 = 1030 A, etc.
V	Nominal supply voltage 5 = 380-500 VAC / 465-800 VDC 6 = 525-690 VAC / 640-1100 VDC
A	Control keypad A = standard (alpha numeric)
0	Enclosure class 0 = IP00, F19-13
T	EMC emission level T = IT networks (EN61800-3)
0	Internal brake chopper 0 = N/A (no brake chopper)
2	Delivery include 2 = AFE module
S	S = Standard air cooled drive U = Standard air cooled power unit - external supply for main fan
F	Hardware modifications; module type - S Boards F = Fiber connection, standard boards, F19-F113 G = Fiber connection, varnished boards, F19-F113
A1	Option boards: Each Two-digit code represents a card slot in order from left to right, Slot A, Slot B, Slot C, Slot D, Slot E A = Basic I/O Cards B = I/O Expansion Cards C = Communications Cards D = Special Option Cards
A2	
00	
00	
00	

VACON LCL FILTERS FOR AFE

VACON LCL AAAA V A 0 R 0 1 1 T

LCL	Product range LCL = LCL filter for AFE
AAAA	Nominal current eg. 0460 = 460 A, 1300 = 1300 A <small>0261 5 0460 5 1300 5 0170 6 0325 6 1030 6</small>
V	Voltage Class 5 = 380-500 VAC 6 = 525-690 VAC
A	Version (hardware) A = DC fan without DC/DC power supply B = DC fan with integrated DC/DC power supply
0	Enclosure class: 0 = IP00
R	Reserve
0	Reserve
1	Reserve
1	Cooling fan type 1 = DC fan
T	Manufacturer T = Trafotek

VACON NXI – VACON NXP INVERTER UNITS (INU)

NX I 0520 5 - A 2 T 0 C S S - A1 A2 00 00 00

NX	Product generation
I	Module type I = INU Inverter
AAAA	Nominal current (low overload) eg. 0004 = 4 A, 0520 = 520 A, etc.
V	Nominal supply voltage 5 = 380-500 VAC / 465-800 VDC 6 = 525-690 VAC / 640-1100 VDC
A	Control keypad A=standard (alpha numeric)
2	Enclosure class 5 = IP54, FR4-7 2 = IP21, FR4-7 0 = IP00, FR8, F19-14
T	EMC emission level T = IT networks (EN61800-3)
0	0 = N/A (no brake chopper)
C	C = INU - with integrated charging circuit, FR4-FR8 I = INU - no charging circuit, F19-F114
S	S = Standard air cooled drive U = Standard air cooled power unit external supply for main fan
S	Hardware modifications; module type - S Boards S = Direct connection, standard boards, FR4-8 V = Direct connection, varnished boards, FR4-8 F = Fiber connection, standard boards, F19-F114 G = Fiber connection, varnished boards, F19-F114 If OPT-AF option board is used N = IP54 control box, fiber connection, standard boards, F19-F114 O = IP54 control box, fiber connection, varnished boards, F19-F114
A1	Option boards: Each Two-digit code represents a card slot in order from left to right, Slot A, Slot B, Slot C, Slot D, Slot E A = Basic I/O Cards B = I/O Expansion Cards C = Communications Cards D = Special Option Cards
A2	
00	
00	
00	

VACON NXB – BRAKE CHOPPER UNIT (BCU)

NX B 0520 5 - A 2 T 0 8 S S - A1 A2 00 00 00

NX	Product generation
B	Module type B = BCU Brake Chopper Unit
AAAA	Nominal current (low overload) eg. 0004 = 4 A, 0520 = 520 A, etc.
V	Nominal supply voltage 5 = 380-500 VAC / 465-800 VDC 6 = 525-690 VAC / 640-1100 VDC
A	Control keypad A = standard (alpha numeric)
2	Enclosure class 5 = IP54, FR4...7 2 = IP21, FR4-7 0 = IP00, FR8, F19-13
T	EMC emission level T = IT networks (EN61800-3)
0	0 = N/A (no brake chopper)
8	8 = BCU - with integrated charging circuit. FR4-FR8
S	S = Standard air cooled drive U = Standard air cooled power unit - external supply for main fan
S	Hardware modifications; module type - S Boards S = Direct connection, standard boards, FR4-8 V = Direct connection, varnished boards, FR4-8 F = Fiber connection, standard boards, F19-F113 G = Fiber connection, varnished boards, F19-F113
A1	Option boards: Each Two-digit code represents a card slot in order from left to right, Slot A, Slot B, Slot C, Slot D, Slot E A = Basic I/O Cards B = I/O Expansion Cards C = Communications Cards D = Special Option Cards
A2	
00	
00	
00	

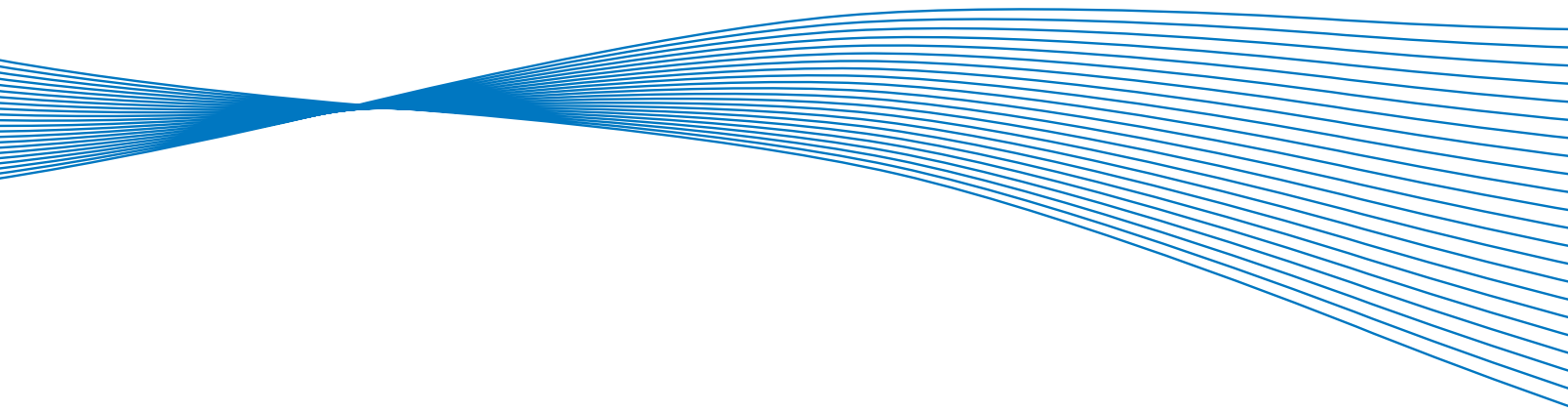

APPENDIX

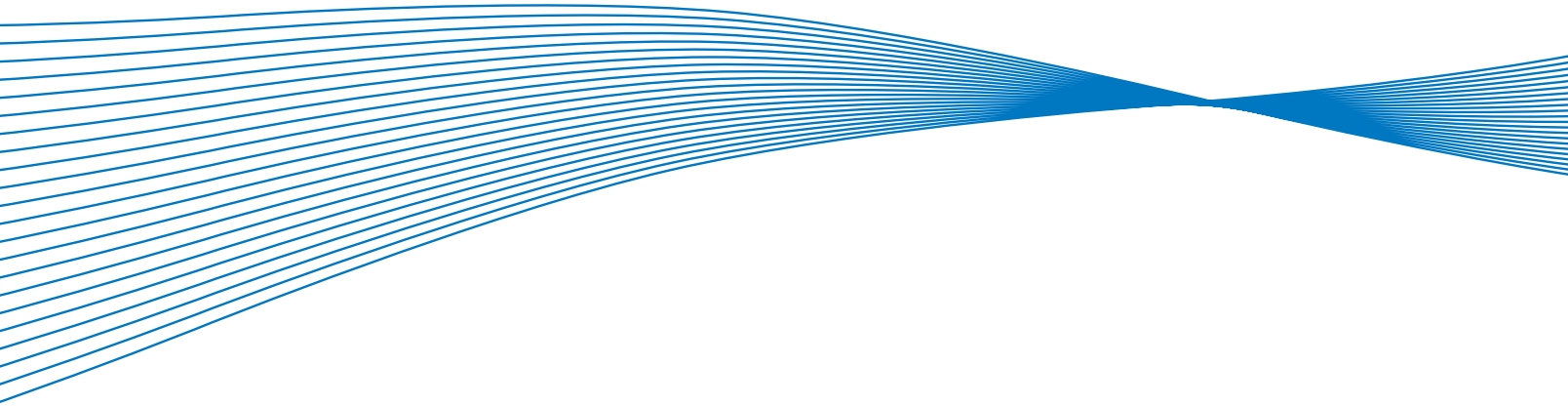

APPLICATION GUIDE BY INDUSTRY REQUIREMENTS

The chart on these pages provides requirements — such as HP range, speed range, load type and torque — when applying AC drives to industrial machinery, including pumps, fans, conveyors or extruders, to name a few, in a variety of industries. It also provides recommended control types for all listed applications: Volts per Hertz, Sensorless Vector, and Flux Vector.

	Application Requirements						Control Type		
	Typical HP Range	Speed Range	Load Type	Regen Loading (NR/RG)	Starting Torque (%)	Running Torque (%)	Volts per Hertz	Sensorless Vector	Flux Vector
AUTOMOTIVE TESTING									
Chassis Testers	100-400	10:1	HO	RG	150	150		X	X
Conveyors	5-250	3:1	HO	NR	150	125	X	X	
Engine Testers	50-400	10:1	HO	RG	150	150		X	X
Fans	5-400	3:1	LO	NR	25	110	X	X	
Pumps	5-400	3:1	LO	NR	40	100	X	X	
Transmission Testing	5-400	10:1	HO	RG	150	150		X	X
CEMENT									
Conveyors/Feeders	10-150	10:1	HO	NR/RG	150	150	X	X	X
Fans	10-400	3:1	LO	NR	25	25	X	X	
Kilns	150-400	5:1	HO	NR	250	250	X	X	X
Packers/Separators	150-400	5:1	HO	NR	150	150	X	X	X
Pumps	10-500	3:1	LO	NR	150	150	X	X	X
FOOD									
Copper	5-100	10:1	HO	NR	50	100	X	X	X
Centrifuge	10-200	10:1	HO	RG	150	125	X	X	X
Conveyors	1-25	10:1	HO	NR	150	125	X	X	X
Extruder	5-100	10:1	HO	NR	150	125	X	X	X
Fans	10-100	3:1	LO	NR	25	110	X	X	
Kettle Cooker	10-200	10:1	HO	NR	100	110	X	X	X
Mixers	1-400	10:1	HO	NR	150	125	X	X	X
Pumps	10-100	3:1	LO	NR	40	100	X	X	
Seamer	5-50	10:1	HO	NR	40	100	X	X	X
Slicer	5-50	10:1	HO	NR	40	100	X	X	X
GLASS									
Float Liners	50-250	20:1	HO	NR	150	125		X	X
Rubber Tire Gantry Cranes	20-300	20:1	HO	NR/RG	150	150			X
Quay Cranes	25-400	20:1	HO	RG	150	150			X
METALS									
Adjustment Drives	1-25	100:1	HO	RG	150	150		X	X
Coiler(s)	100-400	4:1	HO	RG	175	175		X	X
Conveyors	10-400	10:1	HO	NR	150	125	X	X	X
Crop Shear	100-400	4:1	HO	NR/RG	450	450		X	X
Fans-boilers, Oven	150-400	3:1	LO	NR	25	110	X	X	
Helper Rolls	5-25	100:1	HO	RG	100	150		X	X
Low Hp Auxiliary Drives	15-400	20:1	HO	RG	200	200		X	X
Material Handling	5-50	10:1	HO	RG	100	150		X	X
Pumps & Fans	5-300	4:1	LO	NR	100	100	X	X	
Runout Tables (multi-mtr)	100-400	20:1	HO	RG	200	200		X	X
Slitters & Trimmers	10-100	10:1	HO	RG	150	150		X	X
Table Drives	10-400	10:1	HO	NR	150	125	X	X	X
MINING									
Conveyors	100-400	10:1	HO	NR/RG	150	150	X		X
Fans	10-400	3:1	LO	NR	25	25	X	X	
Grinders, Crushers	100-400	10:1	HO	NR/RG	150	150	X	X	
Pumps	10-400	3:1	LO	NR	40	40	X	X	

APPLICATION GUIDE BY INDUSTRY REQUIREMENTS

	Application Requirements						Control Type		
	Typical HP Range	Speed Range	Load Type	Regen Loading (NR/RG)	Starting Torque (%)	Running Torque (%)	Volts per Hertz	Sensorless Vector	Flux Vector
MISC.									
Elevators	1-150	10:1	HO	RG	275	275			X
Wind Tunnels	5-400	10:1	LO	RG	50	125	X	X	
PULP & PAPER									
Boiler Fans	50-400	3:1	LO	NR	25	110	X	X	
Calenders	25-400	10:1	HO	NR	150	110	X	X	X
Dry End Paper Machine	5-400	10:1	HO	RG	100	200		X	X
Fans & Pumps	20-400	3:1	LO	NR	25	100	X	X	
Paper Converting-Transport	3-150	10:1	HO	NR/RG	150	150	X	X	X
Paper Rolls	2-25	10:1	HO	NR/RG	50	150		X	X
Pumps: Feed, Couch Pit Liquor, Water	5-400	3:1	LO	NR	40	100	X	X	
Pumps-Thickeners, Fans, Decker, Washer	5-400	3:1	HO	NR	150	125	X	X	X
Screw Conveyors	15-400	10:1	HO	NR	150	125	X	X	X
Slitters	5-50	10:1	HO	NR	25	100	X	X	X
Wet End Paper Machine	100-400	10:1	HO	NR	100	150		X	X
Winder Auxiliaries	5-100	20:1	HO	RG	50	150		X	X
Winder Drums	50-400	20:1	HO	RG	100	200		X	X
Winder/Unwind	100-400	20:1	HO	RG	100	200		X	X
PETROCHEMICAL									
Beam Pump (Pump Jack)	5-400	3:1	HO	RG	100	125	X	X	X
Compressors	50-400	3:1	LO	NR	40	100	X	X	
Progressive Cavity Pump	5-400	3:1	HO	NR	100	125	X	X	X
RUBBER/PLASTICS									
Calenders, Mills	25-400	10:1	HO	RG	200	150		X	X
Compressors	10-400	3:1	LO	NR	40	100	X	X	
Conveyors	1-100	10:1	HO	NR	150	125	X	X	X
Extruders, Mixers	5-400	10:1	HO	NR	200	200	X	X	X
Fans	10-400	3:1	LO	NR	25	110	X	X	
Pelletizers	25-400	10:1	HO	NR	150	125	X	X	X
Process-Transport Rolls	1-400	10:1	HO	RG	50	150		X	X
TEXTILES									
Fans	5-400	10:1	HO	NR	25	110	X	X	X
Fiber Spinning	1-400	10:1	HO	NR	20	100	X	X	X
Range Drives	50-400	10:1	HO	NR	150	150		X	X
Transport Rolls	10-400	20:1	HO	RG	150	150		X	X
WATER/WASTEWATER									
Chemical Feed Pumps	1-150	3:1	LO	NR	40	40	X	X	
Fans	5-400	3:1	LO	NR	25	25	X	X	
Fresh Water Pumps	10-400	3:1	LO	NR	40	40	X	X	
Heating & Ventilation	5-400	3:1	LO	NR	25	25	X	X	
Lift Stations	5-400	3:1	LO	NR	40	40	X	X	
Slurry Pumps	5-400	3:1	LO	NR	150	150	X	X	
Waste Water Pumps	10-400	3:1	LO	NR	40	40	X	X	

HO = High Overload (150%)
 LO = Low Overload (110%)
 RG = Regenerating Load
 NR = Non Regenerating Load

ENCLOSURE SPECIFICATIONS

Vacon drive products are constructed to be environmentally versatile – whether the application is indoors, outdoors, or in extremely harsh washdown situations. Our products are packaged and independently certified to meet both UL Type and European IP rating enclosure systems.

The UL Type system is used primarily in North America and the IP system is used in Europe and the rest of the world. Our products are packaged in UL Type and IP enclosures to meet virtually any application.

UL Type 1 – Enclosures constructed for indoor use to provide a degree of protection to personnel against incidental contact with the enclosed equipment and to provide a degree of protection against falling dirt.

UL Type 3R – Enclosures constructed for either indoor or outdoor use to provide a degree of protection to personnel against incidental contact with the enclosed equipment; to provide a degree of protection against falling dirt, rain, sleet, and snow; and that will be undamaged by the external formation of ice on the enclosure.

UL Type 4X – Enclosures constructed for either indoor or outdoor use to provide a degree of protection to personnel against incidental contact with the enclosed equipment; to provide a degree of protection against falling dirt, rain, sleet, snow, windblown dust, splashing water, hose-directed water, and corrosion; and that will be undamaged by the external formation of ice on the enclosure.

UL Type 12 – Enclosures constructed (without knockouts) for indoor use to provide a degree of protection to personnel against incidental contact with the enclosed equipment; to provide a degree of protection against falling dirt; against circulating dust, lint, fibers, and flyings; against dripping and light splashing of non-corrosive liquids; and against light splashing and consequent seepage of oil and non-corrosive coolants.

It is important to specify the difference between NEMA enclosure ratings and UL Type enclosure ratings. If a product is deemed to have a NEMA rated enclosure it has been designed with the intent to meet the requirements as described above. To receive the UL Type enclosure ratings, the product must be independently verified by a certified UL testing agency to meet the testing requirements of UL.

IP RATING TABLE

SOLIDS		LIQUIDS	
0	No protection	0	No protection
1	Protected against objects > 50mm (hands)	1	Protection against dripping water or condensation
2	Protected against objects > 12mm (fingers)	2	Protection against water spray 15 degree from vertical
3	Protected against objects > 2.5mm (tools/wires)	3	Protection against water spray 60 degree from vertical
4	Protected against objects > 1mm (small tools)	4	Protection against water spray from all directions
5	Protected against dust, limited ingress	5	Protection against low pressure jets of water
6	Totally protected against dust	6	Protected against high pressure water jets and heavy seas
7	N/A	7	Protection against the effects of immersion (6 inches to 3.3 feet)
8	N/A	8	Protected against immersion

UL Type ratings (and NEMA ratings) are not equivalent to the IP Ratings used for international evaluations as described in IEC 529. The drive manufacturer must specify which IP rating and which NEMA/UL Type rating applies for each drive family. NEMA enclosures are classified by type (e.g., Type 1, Type 4, etc.). IP enclosures employ a two-digit system to classify enclosures. The first digit defines the degree of protection provided against contact with solid objects and the second digit defines the protection level against water (e.g., IP54). The higher the number, the more protection provided.

VACON UL TYPE AND IP RATINGS COMPARISON

UL Type Rating	Approximate IP Rating	Vacon Drive
Open Chassis (UL Open Type)	IP00, IP20, IP21	VACON 10, VACON 20, VACON 20 Cold Plate, VACON NXP IP00 Modules, VACON 100 IP00 Modules
UL Type 1	IP21	VACON NXS, VACON NXP, VACON 100, VACON 100 FLOW, VACON 100 HVAC, VACON 10 (with UL Type 1 Conversion Kit), VACON 20 (with UL Type 1 Conversion Kit)
UL Type 12	IP54/IP55	VACON NXS, VACON NXP, VACON 100, VACON 100 FLOW, VACON 100 HVAC
UL Type 3R	IP54, Outdoor Rated	Vacon X Series (125HP and Above)
UL Type 4X	IP66	VACON X Series (up to 100HP), VACON 100 X, VACON 20 X

EMC AND INSTALLATION ENVIRONMENT

The product family standard EN61800-3 sets limits for both emissions and immunity to radio frequency disturbances. The environment has been divided into the first and second environments, in practice, public and industrial networks, respectively.





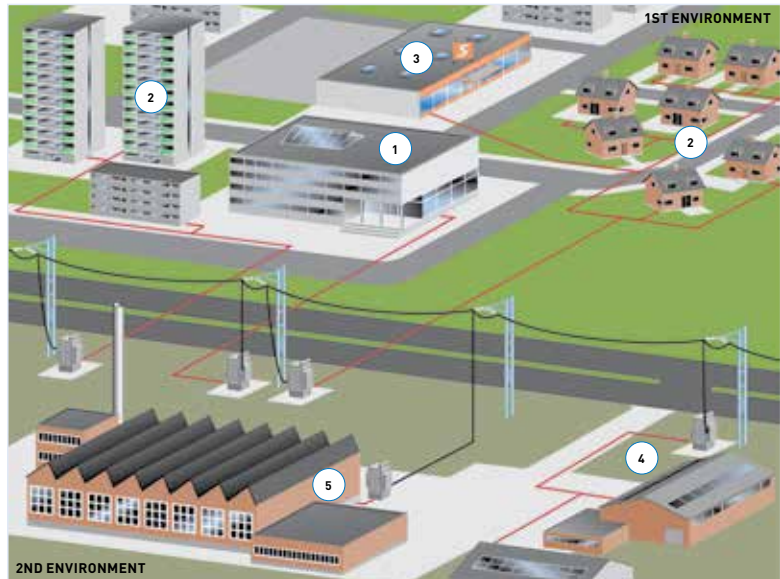

Radio Frequency Interference (RFI) filters are typically required to meet the EN61800-3 standard. These filters are integrated in the Vacon NXP as standard.

The 208–240 V and 380–500 V ranges of the Vacon NXP (FR4-FR9) meet the requirements of the first and second environments (H level: EN61800-3, category C2). No additional RFI filters or cabinets are required. The FR10-FR14 and the 500–690 V ranges of the Vacon NXP meet the requirements of the second environment (L-level: EN61800-3, category C3).



The units in the frame sizes FR4, FR5 and FR6 (with a voltage range from 380 to 500 V) are also available with extremely low-emission integrated EMC filters (C level: EN61800-3, category C1). This is sometimes required in very sensitive locations such as hospitals.

EMC SELECTION TABLE

	1	2	3	4	5	
						
Vacon NXP EMC	Hospital	Residential Area	Commercial	Light Industry Area	Heavy Industry	Marine
C (Category C1)	O					
H (Category C2)	R	R	R	O	O	
L (Category C3)				R	R	
T (Category C4)					R (IT)	R (IT)

Many of Vacon electronic drive products and accessories meet CE, UL, cUL, and C-Tick standards. Products that meet specified standards are identified in this catalog.



The European Community – The CE mark is the official marking for electronic products and equipment sold or put into service anywhere in the European Community. It signifies that the product meets all safety and environmental requirements defined under European Directives.



Underwriters Laboratories Inc. – When a product carries this mark, it means UL found that representative samples of this product met UL's safety requirements. These requirements are primarily based on UL's own published Standards of Safety.



Underwriters' Laboratories of Canada – UL introduced this new Listing Mark in early 1998. It indicates compliance with both Canadian and U.S. requirements. Products with this type of mark have been evaluated for both U.S. and Canadian safety requirements, which have somewhat different safety requirements.

Underwriters' Laboratories has a reciprocal agreement with the Canadian Standards Association where the cUL mark is considered equivalent to the CSA mark for meeting Canadian Safety Standards.



The Canadian Standards Association (CSA) – a non-government, non-profit association that operates internationally to set standards for products and services through testing, certification, and inspections for safety and performance. CSA enhances public safety and health while contributing to environmental preservation.



Australian Compliance – C-Tick is the mark of compliance with testing/evaluation standards in Australia, as developed by a number of organizations, including the Australian Communication Authority.

If you have any questions regarding these agency approvals, please contact your local Vacon sales representative.



Bureau Veritas

The French certification society, Bureau Veritas (BV), issued Marine approvals for the Vacon NX Family of drives on July 24, 2006. Bureau Veritas, founded 1828, is an international group with a core business of conformity assessment, applied in the areas of quality, health, safety, environment and social responsibility.



Det Norske Veritas

The Norwegian certification society, Det Norske Veritas (DNV), issued Marine approvals for the Vacon NX Family of drives on June 18, 2007. DNV Certification is a division of Det Norske Veritas (DNV) an independent foundation established in 1864 as a ship classification society. DNV is one of the world's leading classification societies, and helps the maritime industry manage risk in all phases of the ships life, through ship classification, statutory certification, fuel testing and a range of technical, business risk, financial and competency related services. DNV approval was renewed in November 2012 and is valid until 2014.



American Bureau of Shipping

The American certification society, The American Bureau of Shipping (ABS), issued Marine approvals for the Vacon NX Family of drives on March 30, 2010. The American Bureau of Shipping was founded in 1862 to promote maritime safety. Today, the American Bureau of Shipping strives to be the most efficient provider of marine and offshore classification services and achieves that goal through the innovative thinking, enthusiasm and professionalism of our staff.



Eni

The Italian certification society, Eni, issued approvals for Vacon drives up to 500kW on October 18, 2010 and drives above 500kW on January 22, 2010. Eni, founded in 1953, operates in the oil and gas, electricity generation and sale, petrochemicals, oilfield services construction and engineering industries. In these businesses it has a strong edge and leading international market position.



Lloyd's Register

The British certification society, The Lloyd's Register Group, issued approvals for all Vacon NXS air cooled, Vacon NXP air cooled and Vacon NXP liquid cooled products on April 12, 2011. The Lloyd's Register Group, founded in 1760, is a global independent risk management and safety assurance organization. They provide independent assurance and expert advice across a range of sectors related to transportation and energy.

If you have any questions regarding these marine and offshore approvals, please contact your local Vacon sales representative.

AC drive applications come in all shapes and sizes but they are grouped into one of three basic categories: Constant Torque, Variable Torque or Constant Horsepower. Each system has unique characteristics and sizing of the drive is dependent on the application type as well as the specific characteristics of the given load. A look at each type will help determine in which application category your machine resides.

CONSTANT TORQUE

Constant torque applications are the most common type of load. The basic characteristic is that load demands are the same throughout the designed speed range of the machine. The drive system, consisting of the AC drive and motor, can supply constant torque because the motor can deliver the required horsepower proportional to the speed across the operating range. Matching drive and motor performance is essential to making sure you have enough power for the application. Constant torque loads are found in most industrial environments. Applications such as conveyers, positive displacement pumps, extruders, and hoists are good examples of this loading characteristic. Overloads, shock loading and high-inertia loads are also potential loading issues that are found in constant torque applications. This is where the issue of Normal Duty versus Heavy Duty comes into play.

Three basic characteristics are true for constant torque applications:

1. The same amount of torque is needed to move the load regardless of the operating speed.
2. The load usually requires more torque to break the load loose and start the load moving than to keep it moving.
3. The load has the potential to exceed the motor power rating during operation.

VARIABLE TORQUE

Fans and centrifugal pumps comprise the majority of loads found in the variable torque group. In a fan application, the torque demand will vary with the square of the change in speed and the power requirement will vary as the cube of the change in speed. At full speed, the load requirement is 100% torque and power, but a 50% change in speed creates a 75% decrease in torque demand and a 88% decrease in power required. Fans will occasionally have inertia issues that must be overcome on starting.

Pumps have a similar load characteristic, but often have static pressure issues that must be overcome by the motor making them a little stubborn to start.

For this reason, AC drives are excellent solutions for control of variable torque applications and provide both energy savings and a payback on the drive cost over a short time frame. It is important to look at the load inertia of a fan or the static pressure issues of a pump to consider the overall torque requirements and the short term overload requirements of the load.

CONSTANT HORSEPOWER

Sizing a drive on a constant horsepower application is the most difficult of the three types of applications. In this application type, the speed and torque demands have an inverse relationship. Torque demand is high at low speeds and is low at high speeds. Typical applications, such as center winders and some machine tools, require additional care when selecting a drive/motor combination. Sizing a drive/motor combination for any application is based on the torque demand both at starting and during operating speeds. But you must also account for the designed speed range and torque capacity of the motor. All AC motors have a designed operating range in which they can develop the optimum torque capacity based on the horsepower nameplate rating. Motors operating outside this designed speed range will not develop the torque required for the application. The current demand of the motor to develop this torque is the point at which the drive must be sized. Although drives are rated in horsepower, current capacity will be the deciding factor for reliable operation.

DRIVE OVERLOAD CAPACITY

Each of the Load Characteristics listed describes controlling a load from zero to the base speed of the motor. During acceleration and when extra load is momentarily applied, the demand on the motor and drive can exceed 100% of the capacity of the pair. Every drive and motor has overload capacity built into it for these occasions and the drives are self-protected to prevent damage. Drives like the Vacon X4 and X5 have a dual rating from an overload perspective. Both a Low Overload and a High Overload rating are available on each model. Repeated fast speed changes with high-inertia loads, excessive static friction, short term overloads, shock loading, or in the case of pumps, static pressure loads are potential reasons that might drive you to choose the High Overload rating of the inverter for sizing purposes. If there are no such issues, sizing the drive based on the Low Overload rating is appropriate. These ratings difference are represented as:

- Low Overload - 110% (120% for Vacon X Series) of nominal current for 60s every 10min
- High Overload - 150% of nominal current for 60s every 10min

ELECTRICAL APPLICATION FORMULAS

ELECTRICAL FORMULAS

OHMS LAW:

$$\text{Amperes} = \text{Volts} / \text{Ohms}$$

$$\text{Ohms} = \text{Volts} / \text{Amperes}$$

$$\text{Volts} = \text{Amperes} \times \text{Ohms}$$

POWER IN DC CIRCUITS:

$$\text{Watts} = \text{Volts} \times \text{Amperes}$$

$$\text{Horsepower} = \frac{\text{Volts} \times \text{Amperes}}{746}$$

$$\text{Kilowatts} = \frac{\text{Volts} \times \text{Amperes}}{1000}$$

$$\text{Kilowatt-Hours} = \frac{\text{Volts} \times \text{Amperes} \times \text{Hours}}{1000}$$

POWER IN AC CIRCUITS:

Kilovolt-Amperes (KVA):

$$\text{KVA (Single-Phase)} = \frac{\text{Volts} \times \text{Amperes}}{1000}$$

$$\text{KVA (Three-Phase)} = \frac{\text{Volts} \times \text{Amperes} \times 1.73}{1000}$$

Kilowatt (Kw):

$$\text{Kw (Single-Phase)} = \frac{\text{Volts} \times \text{Amperes} \times \text{Power Factor}}{1000}$$

$$\text{Kw (Two-Phase)} = \frac{\text{Volts} \times \text{Amps} \times \text{Power Factor} \times 1.42}{1000}$$

$$\text{Kw (Three-Phase)} = \frac{\text{Volts} \times \text{Amps} \times \text{Power Factor} \times 1.73}{1000}$$

$$\text{Power Factor} = \frac{\text{Kilowatts}}{\text{Kilovolts} \times \text{Amperes}}$$

CONVERSION FACTORS

	MULTIPLY	BY	TO OBTAIN
Length	Meters	3.281	Feet
	Meters	39.37	Inches
	Inches	.0254	Meters
	Feet	.3048	Meters
	Millimeters	.0394	Inches
Torque	Newton-Meters	.7376	Ft-Lb
	Ft-Lb	1.3558	Newton-Meter
	In-Lb	.08333	Ft-Lb
	Ft-Lb	12.00	In-Lb
Rotation	RPM	6.00	Degrees/Sec.
	RPM	.1047	Rad./Sec.
	Degrees/Sec.	.1667	RPM
	Rad./Sec.	9.549	RPM
Moment of Inertia	Newton-Meters ²	2.42	Lb-Ft ²
	Oz-In ²	.000434	Lb-Ft ²
	Lb-In ²	.00694	Lb-Ft ²
	Slug-Ft ²	32.17	Lb-Ft ²
	Oz-In-Sec ²	.1675	Lb-Ft ²
	Lb-In-Sec ²	2.68	Lb-Ft ²
Power	kW	1.34	HP
	Lb-Ft/Min	.0000303	HP
Temperature	Degree C - (Degree F - 32) x 5/9		
	Degree F - (Degree C x 9/5) + 32		

MECHANICAL FORMULAS

HOW TO CALCULATE TORQUE

If the horsepower and base speed of a motor are known, the full-load torque of the motor is determined by:

$$T = \frac{5250 \times \text{HP}}{N}$$

T = Torque (Ft-Lb)
 HP = Horsepower
 N = Base Speed of Motor (RPM)

HOW TO CALCULATE HORSEPOWER

For Rotating Objects:

$$\text{HP} = \frac{TN}{63,000}$$

T = Torque (In-Lb)
 N = Speed (RPM)

OR:

$$\text{HP} = \frac{TN}{5250}$$

T = Torque (Ft-Lb)
 N = Speed (RPM)

For Objects in Linear Motion:

$$\text{HP} = \frac{FV}{396,000}$$

F = Force (Lb)
 V = Velocity (Inches/Minute)

OR:

$$\text{HP} = \frac{FV}{33,000}$$

F = Force (Lb)
 V = Velocity (FPM)

For Pumps:

$$\text{HP} = \frac{(\text{GPM}) \times (\text{Head in Feet}) \times (\text{Specific Gravity})}{3950 \times (\text{Efficiency of Pump})}$$

For Fans and Blowers:

$$\text{HP} = \frac{\text{CFM} \times (\text{Pressure in Lbs/Sq Ft})}{33,000 \times \text{Efficiency}}$$

Time for motor to reach operating speed (seconds):

$$\text{Seconds} = \frac{WK^2 \times \text{Speed Change}}{308 \times \text{Avg. Accelerating Torque}}$$

$$WK^2 = \text{Inertia of Rotor} + \text{Inertia of Load. (LB-FT)}^2$$

$$\text{Average Accelerating Torque} = \frac{(\text{FLT} + \text{BDT}) + \text{BDT} + \text{LRT}}{3}$$

FLT = Full Load Torque
 BDT = Breakdown Torque
 LRT = Locked Rotor Torque

$$\text{Load } WK^2 \text{ (at Motor Shaft)} = \frac{WK^2 \text{ (Load)} \times \text{Load RPM}^2}{\text{Motor RPM}^2}$$

$$\text{Shaft Stress (Lbs/Sq In)} = \frac{\text{HP} \times 321,000}{\text{RPM} \times \text{Shaft Diameter}}$$

Speed:

$$\text{Synchronous RPM} = \frac{\text{Hertz} \times 120}{\text{Poles}}$$

$$\text{Percent Slip} = \frac{\text{Synchronous RPM} - \text{Full Load RPM}}{\text{Synchronous RPM}} \times 100$$

GLOSSARY

A–C

AC (Alternating Current)	A type of current in which the flow of electrons alternates back and forth as the voltage force alternates between pushing and pulling on electrons.	BACnet	BACnet is a communications protocol for building automation and control networks, designed to allow for applications such as heating, ventilating, and air-conditioning control, lighting control, access control, and fire detection systems and their associated equipment to be controlled from a central console.
Acceleration	A change in velocity as a function of time. Acceleration usually refers to increasing speed of the motor, and deceleration to decreasing speed. Speed is directly proportional to frequency.	Breakaway Torque	The torque required to start a machine in motion. Almost always greater than the running torque.
Accuracy	A measure of the difference between expected position and actual position of a motor or mechanical system. Motor accuracy is usually specified as an angle representing the maximum deviation from expected position.	Brushless Motor	Class of motors that operate using electronic commutation of phase currents, rather than electromechanical (brush-type) commutation. Brushless motors typically have a permanent magnet rotor and a wound stator.
Ambient Temperature	The temperature of the cooling medium, usually air, immediately surrounding the motor or another device.	Bypassing	A means of switching control of the motor from the drive to a starter.
Analog I/O	A type of I/O that may have a value within a set range.	C-Face Mounting	Standards NEMA mounting design, where the mounting holes in the face are threaded to receive the mating mount.
Analog Input	An input to the drive consisting of a variable signal for dynamic adjustment of a setting. Typically either speed or Torque reference.	Canbus	A network used in products with multiple microcontrollers that need to communicate with each other.
Analog Output	An output from a controller that is variable voltage or current in relationship to a real-time parameter.	Carrier Frequency	The rate of change of the PWM signal as measured at the motor terminals. Carrier is twice the switching frequency.
Angular Accuracy	The measure of shaft positioning accuracy on a servo or stepping motor.	CE Mark	The European requirements for equipment sold within the EU. Drives have to comply with the Low Voltage directive and the EMC portions of the specifications.
Armature	Another name for the rotor, which is more commonly referred to in DC motors.	Class B Insulation	A NEMA insulation specification. Class B insulation is rated to an operating (internal) temperature of 130°C.
Back EMF	The voltage generated when a permanent magnet motor is rotated. This voltage is proportional to motor speed and is present regardless of whether the motor winding(s) are energized or de-energized.		

Class F Insulation	A NEMA insulation specification. Class F insulation is rated to an operating (internal) temperature of 155°C.	Continuous Stall Current (I_{CS}) (Amperes)	Amount of current applied to a motor (at locked rotor conditions), which results in rated temperature rise. Refer also to definition of “Continuous Stall Torque.”
Class H Insulation	A NEMA insulation specification. Class H insulation is rated to an operating (internal) temperature of 180°C.	Continuous Stall Torque (T_{CS}) (lb-in)	The amount of torque at zero speed, which a motor can continuously deliver without exceeding its thermal rating.
Closed Loop	A broadly applied term, relating to any system in which the output is measured and compared to the input. The output is then adjusted to reach the desired condition. Typical feedback is for speed, pressure, temperature and position.	Converter	An electrical circuit that changes AC power to DC power.
Closed Loop Vector	A common term referring to the control of an AC motor to produce full torque across the entire speed range of the motor down to and including zero speed. This is only accomplished with the addition of a feedback device on the motor shaft.	Current	The actual flow, and strength of flow, of electrons. Shown in amperes or Amps.
Cogging	A term used to describe non-uniform angular velocity. Cogging appears as jerkiness, especially at low speeds.	Current at Peak Torque (IPK) (Amperes)	The amount of input current required to develop “peak torque.” This is often outside the linear torque/current relationship.
Constant Horsepower	A load in applications where the amount of work to be done is independent of speed and torque, or that requires constant tension.	Current, Rated	The maximum allowable continuous current a motor can handle without exceeding motor temperature limits.
Constant Torque	Loads in applications where the amounts of force needed is independent of speed, and are the most common in industrial applications.	DC (Direct Current)	A type of current in which electrons flow in one continual direction.
Continuous Rated Current (I_{CR}) (Amperes)	The maximum allowable continuous current a motor can handle without exceeding the motor temperature limits.	DeviceNet®	The DeviceNet® network is an open low-level network that provides connections between simple industrial devices (such as sensors and actuators) and higher-level devices (such as PLC controllers and computers).
Continuous Rated Torque (T_{CR}) (lb-in)	The maximum allowable continuous torque a motor can handle without exceeding the motor temperature limits.	D-Flange Mounting	This type of mount has clearance holes on the flange, and the mounting bolts stick out through the flange from the motor side. This mount is common in cases where the motor is integral to the machine.

GLOSSARY

E—F

Digital I/O	A type of I/O which can be either on or off.	Encoder	A feedback device which converts mechanical motion into electronic signals. The most commonly used, rotary encoders, output digital pulses corresponding to incremental angular motion. For example, a 1000-line encoder produces 1000 pulses every mechanical revolution. The encoder consists of a glass or metal wheel with alternating transparent and opaque stripes, detected by optical sensors to produce the digital outputs. Metal tooth gears and magnetic pickups are commonly used as well.
Digital Input	An input to a controller to activate a feature such as direction preset speeds or auxiliary functions.	Ethernet	A local-area network (LAN) architecture developed by Xerox Corporation in cooperation with DEC and Intel in 1976. Ethernet uses a bus or star topology and supports data transfer rates of 10 Mbps. A newer version of Ethernet, called 100Base-T (or Fast Ethernet), supports data transfer rates of 100 Mbps. And the newest version, Gigabit Ethernet supports data rates of 1 gigabit (1,000 megabits) per second.
Digital Output	An output from a controller to show the status of the controller's operation. Typically shows when a condition is true or false.	E-trAC®	Family name of AC drives built by TB Wood's
Diode Rectifier	Similar to SCRs, but diodes do not have a gate and thus cannot be controlled. Diodes only allow the positive portion of AC power to pass through the converter. Most AC drives use diodes.	Feedback	A signal which is transferred from the output back to the input for use in a closed loop system.
DPBV (Dripproof Blower Ventilated)	Type of motor cooled by blowing air through the inside of the motor using an attached blower.	Feedback Devices	Sensors on the motor, or on a process line, that monitor actual performance. Transducers and encoders are examples.
Drive	An electronic device that controls torque, speed and/or position of an AC or brushless motor.	Field Test	A means of determining the nature of the load, if it is not obvious.
Duty Cycle	For a repetitive cycle, the ratio of on time to total cycle time. Duty cycle (%) = [On time / (On time + Off time)] x 100%.	Flux Vector (closed loop vector)	A common term referring to the control of an AC motor to produce full torque across the entire speed range of the motor down to and including zero speed. This is only accomplished with the addition of a feedback device on the motor shaft.
Dynamic Braking	A means of braking when a motor acts as a generator and the drive dissipates the excess energy.		
EPROM	Electronic Programmable Read Only Memory		
EEPROM	Erasable Electronic Programmable Read Only Memory		
Efficiency	The ratio of power output to power input.		
Enclosure	An outer covering that protects electrical devices that comprise the control aspects of the drive.		

Four Quadrant	Refers to a motion system that can operate in all four quadrants; i.e., velocity in either direction or torque in either direction. This means that the motor can accelerate, run, and decelerate in either direction.	Holding Torque	Sometimes called static torque, holding torque specifies the maximum external torque that can be applied to a stopped, energized motor without causing the rotor to rotate. Generally used as a figure of merit when comparing motors.
Frequency	A reference to how often AC changes polarity, and is measured in units of Hertz (or cycles per second).	Horsepower (HP)	An index of the amount of work a machine or motor can perform. One horsepower is equal to 746 watts. Since power is equal to torque multiplied by speed, horsepower is a measure of a motor's torque and speed capability; e.g., a 1 HP motor will produce 36 lb-in. at 1,750 rpm. Formula: $HP = \text{Torque (lb-in.)} \times \text{Speed (RPM)} / 63,025$ or $HP = \text{Torque (lb-ft.)} \times \text{Speed (RPM)} / 5,252$ or $HP = \text{Volts} \times \text{Amps} \times \text{Efficiency} / 746$
Frequency Resolution	The increment of control provided within the design of the controller. In most AC drives, the analog resolution is stated as a number of bits used in the microprocessor. The higher the bit count, the better the resolution. In units with a digital keypad, the resolution is in how small of an increment the Hertz can be adjusted. Typically in either 0.01 or 0.05 Hz steps.	IEC	The International Electro-technical Commission, which writes international standards for electrical devices.
Frequency Stability	The long-term variance of the speed signal to the motor. Provided in a percentage of commanded signal. For example, 0.1% over 24h +/- 10°C change.	IEEE	The Institute of Electrical and Electronic Engineers, which is an association that writes standards.
Frequency-Switching	The rate at which the output power devices are turned on and off as part of the Inverter section of the drive. See also PWM Frequency and Carrier Frequency.	Inductance (L) (mH = millihenries)	The electrical equivalent to mechanical inertia; that is, the property of a circuit, which has a tendency to resist current flow when no current is flowing, and when current is flowing has a tendency to maintain that current flow. Line/Load reactors are an example of how this characteristic helps suppress spikes and surges over and above the norm.
Friction	A resistance to motion caused by contact with a surface. Friction can be constant with varying speed (Coulomb friction) or proportional to speed (viscous friction).	Inductance (Mutual)	Mutual inductance is the property that exists between two current-carrying conductors or coils when magnetic lines of force from one link with those of the other. The basis for how a transformer works.
Harmonics	A special type of noise resulting from AC drives sinusoidal waves with higher frequencies than the main power supply, which are transmitted back to the AC line.		

GLOSSARY

I–M

Inertia	The property of an object to resist change in velocity unless acted upon by an outside force. Higher inertia objects require larger torque to accelerate and decelerate. Inertia is dependent upon the mass and shape of the object.	Load Cells	A type of feedback device that provides signals based upon characteristics of the connected application. Usually measures weight or force.
Inertial Match	For most efficient operation, the system-coupling ratio should be selected so that the reflected inertia of the load is equal to the rotor inertia of the motor.	LonWorks	Enables control of several processes at once and allows convenient keypad programming. LONWORKS is a registered trademark of Echelon Corporation.
Injection Braking	A means of braking an AC motor by sending DC voltage to the motor to create a non-rotating magnetic field.	Metasys (N2)	An open system since 1992 used in many different applications. It allows communication through device level networks at the factory floor, cell level networks (field buses) at the manufacturing level and 10/100 Ethernet for upward communications
Insulated Gate Bipolar Transistor (IGBT)	A transistor used in AC drives to generate AC power from DC power through a control strategy called Pulse Width Modulation (PWM). IGBTs have replaced standard bipolar transistors over the years because of their higher efficiencies and higher switching frequencies that help with quiet motor operation.	Mid-range Instability	A phenomenon in which a step motor can fall out of synchronism due to a loss of torque at mid-range speeds. The torque loss is due to the interaction of the motor's electrical characteristics and the driver's electronics. Some drivers have circuitry to eliminate or reduce the effects of mid-range instability.
Insulation Class	The rating assigned to the maximum temperature capability of the insulating components in a motor or other piece of equipment.	MODBUS®	MODBUS Protocol is a messaging structure developed by Modicon in 1979. It is used to establish master-slave/client-server communication between intelligent devices and transfer discrete/ analog I/O and register data between control devices.
Inverter	A component of an AC drive that takes the regulated DC power and changes it back into a form of regulated (controlled) AC power. Also a common term used for an AC Drive.	MODBUS® RTU	MODBUS network using RTU (Remote Terminal Unit) Mode. This mode uses greater character density to allow better data throughput than ASCII for the same baud rate. Each message must be transmitted in a continuous stream.
I/O	Input/Output		
IrDA	Infrared Data Association Standards		
Load	The equipment being driven by the motor.		

NEMA	The National Electrical Manufacturers Association, which creates standards followed in the USA. The organization that sets standards for motors and other industrial electrical equipment.	Packaging	The metal or plastic enclosure protecting the internal drive components.
Noise	Disruptions in a power or control system. Can be high or low frequency based on use of line suppression devices such as reactors, or controls devices such as shielded or twisted cable can help minimize its affect.	Phases	A reference to how many currents (or voltage forces) are transmitted at one time.
NTC (Negative Temperature Coefficient)	A negative temperature coefficient thermistor is used to detect and protect a motor winding from exceeding its maximum temperature rating. Resistance of the device decreases with an increase in temperature.	PI Control	Proportional-Integral-acting control.
Open Loop Vector	A type of AC regulator that controls motor speed without feedback devices, regulates the current output to the motor, and controls the rotor/shaft speed by controlling the frequency of the magnetic flux in the stator. Also referred to as sensorless vector.	PID	A Proportional-Integral-Derivative controller (PID) is a standard feedback loop component in industrial control applications. It measures an “output” of a process and controls an “input”, with a goal of maintaining the output at a target value, which is called the “set point”.
Open-Loop	A system in which there is no feedback. Motor motion is expected to faithfully follow the input command. Typical control scheme for both Volts per Hertz and Sensorless Vector Control.	Poles	Refers to the number of magnetic poles arranged on the rotor of the motor. In an AC motor, the number of poles has a direct relationship to the base speed of the motor.
Overload Capacity	The ability of a drive to withstand currents above its continuous rating. It is defined by NEMA as 150% of the rated full-load current for “standard industrial motors” for one minute.	Power	<ol style="list-style-type: none"> 1. The rate at which work is done. In motion control, power is equal to torque multiplied by speed. 2. The rate of doing work or expending energy. It may be written as: Power (watts) = force x distance/ time. Expressed in electrical terms it is voltage x current = power (watts)
		Power Factor	Ratio of true power (kW) to apparent power (kVA).
		PROFIBUS DP	A performance optimized version of PROFIBUS, specifically dedicated to time-critical communication between automation systems and distributed peripherals.

GLOSSARY

P—R

PSLC	Programmable Sequence Logic Controller allows the user to implement complex functions and limits based upon speed and load as well as other thresholds along with assigning desired ramps and dwell times.	Regulator	The control portion of the drive that determines what voltage and current is supplied to the motor, and the circuit through which power is supplied to the motor.
PTC (Positive Temperature Coefficient)	A positive temperature coefficient thermistor is used to detect and protect a motor winding from exceeding its maximum temperature rating. Resistance of the device increases with an increase in temperature.	Repeatability	The degree to which a parameter such as position or velocity can be duplicated.
Pull-out Torque	The maximum friction loads, at a particular inertial load, that can be applied to the shaft of a synchronous motor (running at constant speed) and not cause it to lose synchronism.	Resistance	The “frictional” force in wires opposing the flow of current.
Pulse Width Modulation (PWM)	A control strategy which uses Insulated Gate Bipolar Transistors to approximate an AC power supply by switching a DC supply voltage on and off at fixed frequencies. The length of the on/off interval or voltage waveform is variable.	Resistance, Hot (RH) (Ohms line-to-line)	The motor’s terminal resistance value specified at the hot winding temperature, which is at the motor’s maximum rated temperature.
Rated Current	The amount of current flowing through the drive/motor when under full load.	Resolution	The smallest increment into which a parameter can be broken down. For example, a 1000 line encoder has a resolution of 1/1000 of a revolution.
Reference	The analog or digital signal given to a Drive for either speed or torque command.	Resolver	An electromagnetic feedback device that converts angular shaft position into analog signals. These signals can be processed in various ways, such as with an RDC (resolver-to-digital converter) to produce digital position information. There are two basic types of resolvers: transmitter and receiver. A transmitter-type is designed for rotor primary excitation and stator secondary outputs. Position is determined by the ratio of the sine output amplitude to cosine output amplitude. A receiver-type is designed for stator primary excitations and rotor secondary output. Position is determined by the phase shift between the rotor output signal and one of the primary excitation signals.
Regeneration	The action during motor braking in which the motor acts as a generator and takes kinetic energy from the load, converts it to electrical energy, and returns it to the controller.	Resonance	Oscillatory behavior caused by mechanical limitations. This behavior is usually thought of as continuous.
Regenerative Braking	A form of dynamic braking in which the power is dissipated back into the main AC line, rather than through resistors.		

Ringing	Oscillation of a system following a sudden change in state. Usually will diminish over time.	Speed	Describes the linear or rotational velocity of a motor or other object in motion.
Rotor	The moving part of the motor.	Speed Range	The designed operational limits of an AC drive motor combination. Typically stated as a ratio such as 20:1 to indicate base frequency down to 1/20 th of its base speed (1800 to 90 rpm).
Sensorless Vector	A control scheme used in AC drives to assist the motor in developing full torque capacity over the largest speed range. A motor model designed into the software of the drive makes assumptions based on commanded speed and current to calculate rotor position. These calculations are used to adjust the PWM signal and thus voltage and frequency to the motor.	Speed Regulation	The ability to have the load run at the precise speed it is commanded. Usually requires a feedback device and software within the control to look at the commanded speed and the actual speed and make the necessary adjustment.
Servo	A high-performance control utilizing similar control scheme to a Flux Vector drive but coupled with a low-inertia PM motor.	Stall Torque	The amount of torque developed with voltage applied and shaft locked, or not rotating. Also known as locked-rotor torque.
Settling Time	The time required for a parameter to stop oscillating or ringing and reach its final value.	Stator	The non-moving part of the motor. Specifically, it is the iron core with the wire winding in it that is pressed into the frame shell. The winding pattern determines the voltage constant of the motor.
Shaft	The part of the rotor that extends outside of the motor case and connects to the equipment to be rotated.	Synchronized	A motor rotating at a speed corresponding correctly to the applied frequency is said to be synchronized. Load torque in excess of the motor's capacity (rated torque) will cause a loss of synchronism.
Shock Loading	A load that produces extremely high peak torque for very short duration. This type of load is associated with conveyORIZED grinding, crushing and separation processes.	Synchronous Speed	The rotational speed on an AC motor if the rotor and the stator are exactly at the same point in time. This speed assumes no slip is occurring.
SCR (Silicon Control Rectifier)	A gated diode that only allows current to pass through it when the current reaches a certain value, which turns on the SCR. DC drive converters typically use this device to transform AC current into a variable and tightly controlled form of DC current.	Tachometer	A device that monitors the actual speed of the motor. Feedback signal is usually an analog DC signal rated at so many volts per 1000 RPM.

GLOSSARY

T–W

TCP	Transmission Control Protocol, is one of the main protocols in TCP/IP networks. Whereas the IP protocol deals only with packets, TCP enables two hosts to establish a connection and exchange streams of data. TCP guarantees delivery of data and also guarantees that packets will be delivered in the same order in which they were sent.	Torque-Braking (Dynamic Braking)	The amount of braking capacity designed into the drive for stopping a regenerative load or torque required to stop the load.
TCP/IP	See above.	Torque-Starting	The amount of torque it takes to accelerate the load to full speed.
Thermal Protection	A thermal sensing device mounted to the motor to protect it from overheating. This is accomplished by disconnecting the motor phases from the drive in an over-temperature condition.	Torque-to-Inertia Ratio	Defined as the motor's holding torque divided by the inertia of its rotor. The higher the ratio, the higher a motor's maximum acceleration capability will be.
Thermal Resistance (Rth) (°C/watt)	An indication of how effectively a unit rids itself of heat; a measure of temperature rise per watts lost.	User/Operator Interface	A means of allowing an operator to program control references to the drive/motor system, and to monitor motor and drive operating conditions.
Thermostat	A temperature sensitive pilot duty device mounted on the interior of the motor to protect it from overheating.	Variable Torque Load	Loads in applications that exhibit both increases in torque and horsepower as speed increases.
Torque	Measure of angular force that produces rotational motion. This force is defined by a linear force multiplied by a radius; e.g. lb-in. Torque is an important parameter of any motion control system. Formula: Torque (lb-ft.) = 5,250 x HP/RPM	Variable Voltage Control	A reference to drives because they manipulate the voltage supplied to the motor.
Torque Constant (KT = lb-ft/A)	An expression of the relationship between input current and output torque. For each ampere of current, a fixed amount of torque is produced.	Velocity	The change in position as a function of time. Velocity has both a magnitude and sign.
		Voltage	The force that pushes or pulls electrons, causing them to flow.
		Voltage Spikes	A type of noise in which large quantities are suddenly transmitted across the line.
		Volts Per Hertz	A type of AC control scheme that controls the frequency of AC power output to the motor, and does not use feedback devices.

1. GENERAL

To the extent not otherwise agreed in writing, these general terms and conditions of sale (“General Terms”) shall apply to all Contracts, offers and order confirmations regarding Vacon’s sale of its Products to any Purchaser of such Products.

2. DEFINITIONS

The following definitions shall apply to these General Terms:

- (i) **“Confidential Information”** shall mean any technological and technical know-how, inventions, product data, processes, designs, drawings, specifications, economic information and any other information, which is marked or notified as being confidential or should, in the exercise of reasonable judgment under the circumstances, be considered as confidential.
- (ii) **“Contract”** shall mean any contract or agreement between the Parties regarding the sale and purchase of Products.
- (iii) **“High Speed Product”** shall mean any Product that is capable of controlling motor operating at the frequency rate of 600 Hz or above.
- (iv) **“IPR”** shall mean any patent, utility model, design patent, design, software, copyright, trademark, know-how, trade secrets and any other intellectual property right.
- (v) **“Party”** shall mean Vacon or the Purchaser separately and “Parties” shall mean Vacon and the Purchaser jointly.
- (vi) **“Products”** shall mean frequency converters, power converters and inverters, their spare and/ or replacement parts as well as optional devices and accessories and other products sold and delivered by Vacon.
- (vii) **“Purchaser”** shall mean any entity purchasing Products from Vacon.
- (viii) **“Service Provider”** shall mean any Subsidiary of Vacon or an independent service provider authorized by Vacon to provide services relating to the Products on behalf of Vacon.
- (ix) **“Subsidiary”** shall mean any company that is directly or indirectly controlled by Vacon Plc. Control means the power to direct management and policies through ownership, voting rights, contract or otherwise.
- (x) **“Third Party Components”** shall mean third party software and/or components which Vacon has licensed or otherwise sourced from a third party to be used as part of Products.
- (xi) **“Vacon”** shall mean Vacon Plc or its Subsidiary selling the Product to the Purchaser.

3. VALIDITY OF QUOTATIONS AND FORMATION OF CONTRACT

3.1 Written quotations by Vacon are valid for thirty (30) days unless otherwise stated in the quotation or terminated earlier by written notice. Oral quotations, unless accepted by the Purchaser, expire at the end of the day they are made.

3.2 Each Contract shall be concluded by a separate

written agreement between the Parties or by a written confirmation by Vacon of the Purchaser’s order. In the case of accepting an oral quotation, a written Contract must be executed within thirty (30) days from the acceptance, otherwise the price and delivery terms may be subject to re-negotiation.

3.3 The Purchaser’s orders are binding when received by Vacon. Vacon’s confirmation of the Purchaser’s order is conditional on the Purchaser’s acceptance of these General Terms. Acceptance of delivery of Products without prior objection to these General Terms shall constitute such acceptance.

4. TERMINATION AND CANCELLATION

4.1 Any order by the Purchaser may be terminated by the Purchaser only by written notice and upon payment of reasonable termination charges, including but not limited to all costs incurred by Vacon until the termination notice is received by Vacon and any and all profit loss sustained by Vacon as a result of such termination.

4.2 Vacon shall have the right to cancel any confirmed order and/or Contract at any time by written notice with immediate effect if the Purchaser (i) breaches any provisions of the Contract and fails to correct such breach within fourteen (14) days from the notice by Vacon demanding such correction, or (ii) enters into any proceeding under law for the relief of debtors, is declared bankrupt, fails to pay its invoices when due or otherwise becomes insolvent.

5. DELIVERY TERM AND TRANSFER OF TITLE

5.1 The Products will be delivered, and are priced, Ex Works (Incoterms, the latest effective version) at Vacon’s production site, unless otherwise agreed in the Contract.

5.2 Title to the Products will pass to the Purchaser when the sales price has been paid in full to Vacon.

6. PRICES AND PAYMENT TERM

6.1 The prices for Products are as agreed in the Contract and are exclusive of VAT and other similar taxes and public charges. Unless otherwise agreed in the Contract, all prices are subject to change without notice. In the event of a price change, the effective date of the change will be the date of the new price or price list, letter or electronic notification. New pricing will be applied in all quotations made by Vacon and in orders confirmed by Vacon after such effective date.

6.2 Unless otherwise agreed, the Products will be invoiced on the date of shipment. Payments shall be made within thirty (30) days from the date of Vacon’s invoice.

6.3 If the Purchaser fails to make any payment in due time, Vacon may, at its discretion, consider the Contract breached, claim all unpaid amounts, claim interest for delayed payment(s) and cancel or suspend any pending deliveries to the Purchaser. Unless otherwise agreed, the delay interest is fifteen per cent (15 %) per annum, however, not more than the highest permitted interest rate under the mandatory provisions of the applicable law.

7. WARRANTY

- 7.1 Vacon hereby warrants that the Products
- (i) will comply with the specifications jointly and specifically agreed to by the Parties, or, in the absence of such jointly and specifically agreed specifications, Vacon's standard specifications in effect at the time of manufacture, and that
 - (ii) the Products, as originally delivered by Vacon, are free from defects in material and workmanship.
- 7.2 Vacon shall not be responsible for any defects due to the Purchaser's negligence or misuse, modification or rework, combination, incorrect installation, commissioning or maintenance, unauthorized dismantling, abnormal or exceptional working, installation, commissioning or operation conditions, or the Purchaser's failure to adhere to Vacon's instructions and specifications. Neither shall Vacon be responsible for (i) normal wear and tear, (ii) for defects arising from the use of spare parts other than those approved by Vacon, or (iii) for damages arising from the Purchaser's failure to ensure information security in the environment where the Products are used.
- 7.3 The warranty period is
- eighteen (18) months from the date of shipment of the Product from Vacon; or twelve (12) months from the commissioning thereof; whichever occurs first; or
 - such longer warranty period as required by the mandatory provisions of the applicable law; or
 - thirty-six (36) months from date of shipment from Vacon; or twenty-four (24) months from the commissioning thereof; whichever occurs first for Vacon X-Series.
- 7.4 The warranty period for repaired or replaced Product or its part shall be equivalent to the remaining warranty period of the originally delivered Product or three (3) months from the repair or replacement of such Product or its part, whichever is longer.
- 7.5 Provided that the Purchaser has notified in writing Vacon (or its Service Provider as provided for in section 7.6 below) of the defect within five (5) working days after discovery of the defect and within the above warranty period, Vacon shall, at its discretion, (i) either repair the defective Product, (ii) replace the defective Product by an equivalent non-defective Product, or (iii) refund the purchase price of the defective Products. In case Vacon decides to replace the defective Products and requests the return of such defective Products, the Purchaser shall refrain from any actions preventing or interfering with a proper analysis of the cause of the defect, store the defective Products in proper conditions and deliver the defective Products to Vacon (or its Service Provider, as the case may be) within five (5) working days from Vacon's request. Vacon shall reimburse the transportation costs arising from the return of defective Products under the warranty herein provided that the forwarding agent recommended by Vacon has been used. Vacon is not responsible for any additional costs and expenses caused by the dismantling, installation or commissioning of a repaired or replaced Product, travelling, accommodation, daily allowances or time used for travelling by the authorized service personnel.

7.6 All communication relating to claims shall be between the Purchaser and the Service Provider and possible returns of defective Products shall be made by the Purchaser to such Service Provider.

7.7 The warranties above and in section 9.2 are exclusive and are in lieu of all other warranties, whether written or oral, implied or statutory. VACON AND THE PURCHASER HEREBY WAIVE ANY WARRANTY OF MERCHANTABILITY AND WARRANTY OF FITNESS FOR A PARTICULAR USE. Vacon shall not be liable for any other activity and/or cost than those set forth in section 7.5 above.

8. PURCHASER'S WARRANTIES

8.1 The Purchaser hereby represents and warrants that if the Contract covers any High Speed Products, the Purchaser shall comply with all applicable provisions (if any) of the Council Regulations (EC) setting up a Community regime for the control of exports, transfer, brokering and transit of dual-use items, and other applicable control regime as valid from time to time.

8.2 The Purchaser further represents and warrants that any Products shall not be used, nor transferred to third parties to be applied, in connection with a nuclear facility nor in production, development, handling, operation, maintenance, storage, detection, identification or dissemination chemical, biological or nuclear weapons or other nuclear explosive devices or the development, production, maintenance or storage of missiles capable of delivering such weapons.

8.3 Vacon retains the right to redeem the Products (without any compensation to the Purchaser) in case the information provided by the Purchaser or otherwise regarding the end user of the Product seems, at the sole discretion of Vacon, to be false.

9. INTELLECTUAL PROPERTY RIGHTS

9.1 The sale and delivery of any Products to the Purchaser shall not transfer, confer or grant to the Purchaser any IPR to the Products or related documents, save the right of normal use and/or sale of Product and related documents in the Purchaser's ordinary business.

9.2 Vacon hereby warrants that the Products, as delivered, do not infringe upon any IPR of third parties in the country of delivery. In case of any infringement, or anticipated infringement, the Purchaser shall immediately notify Vacon in writing thereof, empower Vacon to defend the case and give Vacon any support requested. Vacon may, at its sole discretion, either (i) replace the infringing Product with a non-infringing Product that materially corresponds to the agreed specification of the relevant Product, (ii) acquire to the Purchaser a royalty-free license to use the Product, or (iii) redeem the infringing Product and return the corresponding sales price. The warranty and remedies above are the sole remedies available to the Purchaser in case of a possible infringement of third party IPRs.

10. THIRD PARTY COMPONENTS

Vacon's delivery may contain Third Party Components. Vacon shall be entitled, at its sole discretion and at any time, to add, remove or replace any Third Party Components in any Product. All IPRs to the Third Party Components shall belong to such third party. Vacon or the third party will grant the Purchaser a limited, non-exclusive and non-transferable license to use the Third Party Component solely in connection with the use of Product and subject to such third party's license and other delivery terms and conditions. Vacon neither assumes any liability nor gives any warranty of any kind for the Third Party Components and the Purchaser shall entirely satisfy itself with the warranty and indemnity, if any, granted by such Third Party Component supplier.

11. FORCE MAJEURE

Vacon shall not be liable to the Purchaser for failing to fulfill its obligations as a result of circumstances beyond its reasonable control, including without limitation fire, explosion, accident, strike, lockout, flood, drought, embargo, war (whether declared or not), riot, natural disasters or acts of the public enemy, action of any governmental authority, general shortage of material or transportation, or the delay or non-performance of a sub-contractor due to the above reasons.

12. CONFIDENTIALITY

Each Party shall, during the term of the Contract and thereafter, hold in confidence and not disclose to any third party any Confidential Information which has been disclosed to it by the other Party in connection with the Contract or otherwise learned by it in connection with the delivery of the Products. The Parties shall not use any Confidential Information for any other purpose than for the proper performance of the Contract and the delivery of the Products. The above obligations of confidentiality and non-use shall not apply to Confidential Information which the receiving Party by written records demonstrate (i) was in its possession prior to the first receipt thereof from the disclosing Party, and/or (ii) which becomes a matter of public knowledge without a breach of the confidentiality obligation hereunder, and/or (iii) which is obtained from a third party under circumstances permitting its disclosure to others.

13. LIMITATION OF LIABILITY

Each Party's maximum liability to the other for damages arising from the sale and purchase of Products shall never exceed the net invoiced value of the relevant Product. In no event shall either Party be liable to the other for loss of production, loss of profits, business, revenue, data or goodwill, cost of capital, losses arising from plant shut down, labor charges or other consequential, incidental, indirect, special or punitive damages.

The aforesaid limitations of liability shall not, however, apply in cases where damages are caused by (i) willful misconduct or gross negligence, (ii) culpable injury to life, body or health, (iii) defects which have maliciously been concealed or whose absence has been specifically guaranteed or (iv) personal injury or damages to property when there is strict liability under the applicable mandatory product liability laws for such damages.

14. SEVERABILITY

The provisions of these General Terms are intended to be severable. If any provision or part thereof is held invalid, then the rest of the General Terms shall remain in full force and effect.

15. GOVERNING LAW AND DISPUTE RESOLUTION

15.1 These General Terms as well as any other terms of the Contract shall be governed by the laws of the country/ state in which the contracting Vacon entity is located, without, however, giving effect to the rules on conflict of laws within such jurisdiction. The Vienna (UN) Convention on Contracts for the International Sale of Goods shall not apply. 15.2 Any dispute, controversy or claim arising out of or relating to the Contract, or the breach, termination or validity thereof shall be finally settled by arbitration. The arbitration shall be governed by (i) the Commercial Arbitration Rules of the American Arbitration Association ("AAA") for disputes governed by U.S. law, (ii) the Arbitration Rules of the China International Economic and Trade Arbitration Commission ("CIETAC") for disputes governed by Chinese law, or (iii) by the Rules of Arbitration of the International Chamber of Commerce ("ICC") for disputes governed by any other law than those mentioned above. The place of arbitration shall be Vacon's domicile, and the arbitration shall be conducted in the English language. Notwithstanding the foregoing, (i) Vacon shall, however, be entitled to lodge claims concerning the collection of outstanding debts in any court having jurisdiction over the Purchaser; and (ii) the parties agree that nothing herein shall be construed to prevent parties from seeking injunctive relief for immediate and irreparable harm in such circumstances where such equitable relief is necessitated and no immediate adequate remedy at law is available.

DISTRIBUTOR POLICY

DISTRIBUTOR STOCK

A Distributor must maintain adequate stock to service his trading area in order to be considered an authorized Stocking Distributor and qualify for assistance with training, sales and promotional activities. The Distributor and Vacon Sales Representative will cooperate to:

1. Establish aims, objectives and sales goals by product line.
 - a. Consider the industry in the area, the similar stock presently available, the competitive situation and the Distributor's financial position.
 - b. Review the potential we have developed and sales goals we have established.
2. Determine sizes, styles and types of each product line developed.

It is our objective to avoid Distributor stocks that do not move and have insufficient turns.

MARKETING OPPORTUNITIES

Vacon is an industry leader in AC Drives and has many sales and marketing tools available for you to promote Vacon and our breadth of AC Drives products. For all promotional and literature needs, please visit www.shop.cpipromo.com/store/vacon/. Further sales promotional programs, advertising, marketing and training related questions or needs can be directed to your local sales representative or North American Marketing Manager, Nicki Bowling at nicki.bowling@vacon.com. Vacon retains all rights, including all intellectual property rights, to advertising, literature and sales promotional materials provided. Each Distributor must return all such materials if the Distributor relationship is terminated for any reason and the Distributor must cease using such materials, including materials posted on any internet site. We are committed to providing you with the tools you need to be successful.

SALES TRAINING AND FIELD ASSISTANCE

We will assist our Distributors through our sales education program and Sales Representatives. Sales meetings may be conducted at the Distributor's place of business. In addition, they will work with the Distributor to:

1. Recommend stock, inventory levels, turnover expectations, literature requirements, etc.

2. Aid in training or familiarizing Distributor sales personnel with our products.
3. Acquaint sales personnel with competitive products, point out weaknesses and strengths, and develop counter selling plans.
4. Aid in developing integrated sales and marketing promotional programs for the trading areas.
5. Help close sales to important prospects.
6. Investigate and resolve complaints.

RETURNED GOODS

The policy for returning products for defects in workmanship or materials is covered under the "Product Reliability" section. Distributors who may want to return products that are overstocked or slow moving must obtain prior approval and a Returned Goods Authorization number from Customer Service. This number must be referenced on the returned goods shipment. It allows us to identify the contents of the shipment, the Distributor who originated it and the reason for return. All returns must be sent by prepaid freight and will be subject to a 15% restocking charge. There will be additional charges as necessary for re-boxing and refurbishing. Returned goods must have been manufactured and/or sold by Vacon and must be in new and salable condition. They will be inspected at the factory and if reconditioning is necessary it will be charged to the Distributor. We reserve the right to reject products that are obsolete or not in the original, unopened box.

DISTRIBUTOR STOCK ADJUSTMENT PROGRAM

In addition to our Returned Goods Policy, we provide Distributors with opportunities to adjust their initial stock order. New Distributors may find that their initial inventory does not properly reflect buying trends in their area. New Distributors may, within one year of their initial inventory purchases, return slow-moving products for equal exchange on other items in the same product category. Such returns must be accompanied by an order at least equal in value to the returned products. After the first year, they may return slow-moving products of a value less than or equal to half the value of an accompanying order for new items in the same product category. These stock adjustments must follow our Returned Goods Policy: prior approval, returned goods authorization number, prepaid shipping, saleable condition and current design.

RETURNS

On occasion, distributors may be allowed to return unsold inventory. This material must be in unopened original boxes and of current revision to be considered for restock. This type of request must have management’s approval prior to a RGA being issued. A restocking fee will be deducted from credit amount. Customer is responsible for all freight charges to Vacon.

Order entry errors (wrong model, wrong quantity, etc.) can be returned to Vacon via the RGA system. Shipping costs will be responsibility of Vacon. Account number will be provided (standard shipping only). Vacon North America provides the best warranty and service in the industry! These guidelines allow us to continually improve our response time whenever a service situation arises. As always, we appreciate your business and support.

TERMINATION

Vacon reserves the right to terminate a Distributor whenever we believe that such action is in our best interest. A termination for cause, depending on the circumstances, may be effective immediately or upon any notice period that we believe is appropriate. Vacon North America is under no obligation to accept return of any remaining inventory.

PROCEDURE FOR HANDLING WARRANTY CLAIMS

PRODUCT RETURN PROCEDURE

All Product returns must be made with prior consent of Vacon and with the use of a Returned Goods Authorization (RGA) number. In addition, a valid Purchase Order is required to cover Product inspection costs per fee schedule below in event Warranty is not justified. The Customer is responsible for all freight charges for Product shipments to Vacon.

To initiate a claim under Warranty and request RGA, the Customer may utilize the following contact options depending on installation location:

USA /Mexico - Contact Vacon, Inc. via phone at 1-877-822-6606 or email vaconrgasystem@vacon.com with details of the problem, model number, and the unit’s serial number to request RGA

Canada - Contact Vacon Canada via phone at 905-643-5401 with details of the problem, model number, and the unit’s serial number to request RGA

Product return instructions will be provided at time of RGA issuance. Returns must be made within two weeks or RGA will be cancelled.

Validity of the Warranty Claim will be determined by Vacon after inspection and analysis is completed following Product return. The Product in its entirety must be returned or the Warranty claim will be denied. In event Warranty is not justified by Vacon determination, Non-Warranty procedures will then apply. For valid warranty claims, Vacon will repair or replace the Product at its option. Vacon may also at its option offer to repair in place. However, in event Warranty is not valid, the Customer will be responsible for associated in and out technician charges per published service rate schedules.

If time is of the essence, the Customer may elect to have a replacement Product shipped while the RGA process is underway. This option is available for Products with ratings below 100HP. Replacement Products are normally shipped within one business day. A valid purchase order is required for replacement Products. Once RGA process is completed and Warranty claim is validated, the Customer will be credited for the replacement Product purchase and inspection fees. Should Warranty not be validated, the Customer will be responsible for the replacement Product invoice, standard shipping costs and inspection fees and be given the option to have the returned Product repaired, scrapped in place or returned to Customer as is.

INITIAL INSPECTION FEES

All prices listed in U.S. dollars/Canadian dollars.

Product	Inspection Fee
Accessories and option cards	\$75.00
Vacon 10, Vacon 20	\$75.00
All other Products < 10HP	\$150.00
All other Products 15HP to 200HP	\$250.00
All other Products 250HP to 500HP	\$350.00
All other Products > 500HP	\$400.00
Legacy Products (CX)	\$500.00

EXPEDITE: Same day Inspections will be billed at an Expedite Fee of \$500.00.

POLICIES AND PROCEDURES

PROCEDURE FOR NON WARRANTY REPAIRS

PRODUCT RETURN PROCEDURE

All Product returns must be made with prior consent of Vacon and with the use of a Returned Goods Authorization (RGA) number. In addition, a valid Purchase Order is required to cover Product inspection costs per fee schedule below. The Customer is responsible for all freight charges for Product shipments to Vacon.

To request RGA, the Customer may utilize the following contact options depending on installation location:

USA /Mexico - Contact Vacon, Inc. via phone at 1-877-822-6606 or email vaconrgasystem@vacon.com with details of the problem, model number, and the unit's serial number to request RGA

Canada - Contact Vacon Canada via phone at 905-643-5401 with details of the problem, model number, and the unit's serial number to request RGA

Product return instructions will be provided at time of RGA issuance. Returns must be received within two weeks or the RGA will be cancelled.

Once inspection and analysis is completed by Vacon following Product return, the customer will be given a good faith quotation for repairs. The Product will be held for 15 working days and if there is no response from the Customer on the disposition of the unit, it will be returned to the customer freight collect as is and inspection fees will be invoiced.

If, following Customer approval to proceed, additional

problems are found during the repair process, the Customer will be notified and given a revised quotation detailing expenses incurred to date and additional fees needed to complete repairs. If customer elects to not proceed further, the Product will be returned to customer as is or scrapped in place at Customer direction. Inspection fees and repair costs incurred to date will be invoiced.

Products returned that are found to have no problems will be thoroughly tested and returned to the customer. Inspection fees will apply.

Products returned for evaluation only will be analyzed and a service report will be sent to the Customer along with an invoice for the applicable inspection fee.

If Vacon determines that the returned Product is not feasible or uneconomical to repair, the customer will be notified and the Product will be returned to customer as is or scrapped in place at Customer direction. Inspection fees will be invoiced.

All repairs are warranted per Vacon's Warranty Terms and Conditions.

INITIAL INSPECTION FEES

Product	Inspection Fee
Accessories and option cards	\$75.00
Vacon 10, Vacon 20	\$75.00
All other Products < 10HP	\$150.00
All other Products 15HP to 200HP	\$250.00
All other Products 250HP to 500HP	\$350.00
All other Products > 500HP	\$400.00
Legacy Products (CX)	\$500.00

EXPEDITE: Same day Inspections will be billed at an Expedite Fee of \$500.00.

FIELD SERVICE TERMS AND RATES

**FIELD SERVICE RATES NORTH AMERICA *
ALL PRICES LISTED IN U.S. DOLLARS/CANADIAN DOLLARS.**

*Continental U.S., Canada and Mexico Only

Service Time	Definition	Service Representative	Systems Specialist
Straight, Travel & Standby	8 Hrs/Day 8:00AM-5:00PM Monday-Friday	\$175.00 / Hour	\$205.00 / Hour
Weekday Overtime, Travel & Standby	Hrs Before 8:00AM or Beyond 5:00PM	\$262.50 / Hour	\$307.50 / Hour
Saturday Overtime, Travel & Standby	12:00AM Saturday to Midnight Saturday	\$262.50 / Hour	\$307.50 / Hour
Sunday Overtime, Travel & Standby	12:00AM Sunday to Midnight Sunday	\$350.00 / Hour	\$410.00 / Hour
Holiday Travel & Standby	New Years Good Friday Memorial Day July 4th Labor Day Thanksgiving Christmas	\$437.50 / Hour	\$487.50 / Hour
Commissioning Monday-Friday	Maximum 10 Hours / Day Hours Between 7:00AM and 7:00PM	\$1,800.00 / Day	\$2,100.00 / Day
Commissioning Other Time	Overtime Saturday & Sunday New Years Good Friday Memorial Day July 4th Labor Day Thanksgiving Christmas	Situational Hourly Rates Apply	Situational Hourly Rates Apply

Standby Time: Considered the same as service time and billed at the appropriate rates listed above.

POLICIES AND PROCEDURES

APPLICABLE RATE CHARGE

Service Representative, rates will be charged for field service, field repair and commissioning of products and systems.

Systems Specialist, rates will be charged for specially trained employees for applications, troubleshooting and the commissioning of specially designed systems.

Commissioning days specified or agreed on for a given system or drives are the days normally required to commission a system or drive of this complexity. It must not be assumed that the representative will always be in the customer's plant for this number of days. These days are assigned to include the time and expenses associated with behind scenes start-up activities. These activities include, but not limited to, preparation time, reporting time, technical assistance and miscellaneous costs included in start-up service.

Warranty service provided during the normal workday hours of 8:00 AM to 5:00 PM, Monday through Friday. Customer requests for warranty work on an overtime basis will be considered and the time will be limited by the availability of a representative. The customer will be responsible for the premium portion of the overtime hours.

Warranty labor provided only if Vacon is the provider of the commissioning services. At such time that the commissioning is completed and the customer has accepted the Vacon products, warranty coverage will be in accordance with the standard product warranty as described in the Warranty Terms and Conditions.

MINIMUM BILLING

The minimum daily charge for Field Service is four (4) hours at the appropriate rate plus expenses.

OFF SHIFT PREMIUM

Requests for off shift service will be billed at 15% over appropriate rates.

TRAVEL TIME

Travel Time is defined as any time spent traveling to the jobsite from the representatives Home/Office location or from the representative's previous jobsite. Travel time will be invoiced at appropriate rates listed above.

TRAVEL & LIVING EXPENSES

Auto travel rate (Company Car) - USA: \$0.60/Mile
Auto travel rate (Company Car) - Canada: \$0.54/km
Public Transportation/Auto Rental At Cost**
Lodging, meals, phone, misc., etc. At Cost**
**A 20% handling fee will be added to actual cost

PRICE/PAYMENTS/TAXES

The price for service will be at the rates published currently by VACON, Inc and in effect at the times, the service is performed. Terms are cash net 30 days. VACON, Inc has no obligation to provide service to a customer with a 30-day past due balance.

Taxes as required are added to invoices, service rates do not include taxes or fees.

All payments made in U.S. dollars drawn on a U.S. bank.
All payments made in Canadian dollars drawn on a Canadian bank.

Vacon maintains the following insurance coverage:

- Worker's Compensation and Employee's Liability Insurance
- Comprehensive and General Liability
- Auto Liability and Property Damage

RISK COMPENSATION

All service rates are subject to increase as compensation for performing service in a war hazard zone. All service rates for service performed in a war hazard area will be negotiated before the service engineer is dispatched.

NORTH AMERICA

The following terms and conditions apply to all services which Vacon provides, either by direct employees or contracts to an independent third party, and the service is performed by visitation to the customer's facility. The customer understands that the terms and conditions set below shall be controlling, and any other or additional terms and conditions signed or unsigned can have no effect. Services provided under these terms and conditions only.

FOREIGN SERVICE

The following terms and conditions apply to all service which Vacon provides, by either direct employees or contracts to an independent third party, and the service is performed by visitation to the customer's facility. The customer understands that the terms and conditions set below shall be controlling, and any other or additional terms and conditions signed or unsigned can have no effect. Service will be provided under these terms and conditions only.

Purchaser is expected to have an English speaking interpreter available during all working hours and to advise special visa or other arrangements necessary (if other than standard passport).

If the total length of stay exceeds 21 calendar days due to causes not the responsibility of Vacon, or without prior agreement, Vacon may elect to have its service representative's return to the U.S. and then make a second trip, as necessary, at the purchaser's expense.

TERMS AND CONDITIONS ON THE SALE OF SERVICES

1. General

To the extent not otherwise agreed in writing, these general terms and conditions (“General Terms”) shall apply to any Contracts, offers and order confirmations regarding Vacon’s sale of its Services to any Purchaser of such Services.

Vacon’s separate General Terms and Conditions for the Sale of Products shall be applied to the sale of Products when such Products are sold separately or sold, repaired or replaced or otherwise provided to the Purchaser as part of or in connection with Services, subject, however, to the provision in section 6.4 below.

2. Definitions

The following definitions shall apply to these General Terms:

- (i) “**Confidential Information**” shall mean any technological and technical know-how, inventions, product data, processes, designs, drawings, specifications, economic information and any other information, which is marked or notified as being confidential or should, in the exercise of reasonable judgment under the circumstances, be considered as confidential.
- (ii) “**Contract**” shall mean any contract or agreement between the Parties regarding the sale and purchase of Services.
- (iii) “**IPR**” shall mean any patent, utility model, design patent, design, software, copyright, trademark, know-how, trade secrets and any other intellectual property right.
- (iv) “**Other Charges**” shall mean costs, such as but not limited to, travelling, daily allowances and accommodation costs, transportation costs, handling fee, extra circumstantial costs, packaging costs, material and tools costs or any other costs arising from or relating to the performance of the Services.
- (v) “**Party**” shall mean Vacon or the Purchaser separately and “**Parties**” shall mean Vacon and the Purchaser jointly.
- (vi) “**Product(s)**” shall mean frequency converters, power converters and inverters, their spare and/ or replacement parts as well as optional devices and accessories and other products sold and delivered by Vacon separately or in connection with the Services.
- (vii) “**Purchaser**” shall mean any entity purchasing Services from Vacon.
- (viii) “**Service Provider**” shall mean any Subsidiary of Vacon or an independent service provider authorized by Vacon to provide services relating to the Services on behalf of Vacon.
- (ix) “**Service(s)**” shall mean maintenance, repair or commissioning of the application of Products, training or any other kind of services related to Vacon’s Products provided by the Service Provider to the Purchaser. Any engineering services shall, however, be subject to a separate written agreement between the Parties.

- (x) “**Subsidiary**” shall mean any company that is directly or indirectly controlled by Vacon Plc. Control means the power to direct management and policies through ownership, voting rights, contract or otherwise.
- (xi) “**Vacon**” shall mean Vacon Plc or its Subsidiary selling the Services to the Purchaser.

3. Validity of Quotations and Formation of Contract

- 3.1 Written quotations by Vacon are valid for thirty (30) days unless otherwise stated in the quotation or terminated earlier by written notice. Oral quotations, unless accepted by the Purchaser, expire at the end of the day they are made.
- 3.2 Each Contract shall be concluded by a separate written agreement between the Parties or by a written confirmation by Vacon of the Purchaser’s order. In the case of accepting an oral quotation, a written Contract must be executed within thirty (30) days from the acceptance, otherwise the prices, delivery dates and other such terms may be subject to re-negotiation.
- 3.3 The Purchaser’s orders are binding upon the Purchaser when received by Vacon and upon Vacon when confirmed by it in writing. Vacon’s confirmation of the Purchaser’s order is conditional on the Purchaser’s acceptance of these General Terms. Acceptance of delivery of Services without prior objection to these General Terms shall constitute such acceptance.

4 Changes to Delivery Dates, Termination or Cancellation

- 4.1 Any changes to confirmed delivery dates proposed by either Party due to reasons other than circumstances described in section 11 (Force Majeure) are subject to a prior written approval by the other Party. Said approval may be conditional upon an agreement between the Parties regarding the compensation of additional costs incurred by a Party due to such proposed change.
- 4.2 Any order by the Purchaser may be terminated by the Purchaser only by written notice and upon payment of reasonable termination charges, including but not limited to all costs incurred by Vacon until the termination notice is received by Vacon and any and all profit loss sustained by Vacon as a result of such termination.
- 4.3 Vacon shall have the right to cancel any confirmed order and/or Contract at any time by written notice with immediate effect if the Purchaser (i) breaches any provisions of the Contract and fails to correct such breach within fourteen (14) days from the notice by Vacon demanding such correction, or (ii) enters into any proceeding under law for the relief of debtors, is declared bankrupt, fails to pay its invoices when due or otherwise becomes insolvent.

5. Performance of Services

- 5.1 The Services will be performed at locations and at times set forth in the Contract.
- 5.2 In the event of an urgent Service request from the Purchaser, the terms and practical details for the performance of Services may be agreed orally between the Parties. Such orally agreed terms and details shall be confirmed in writing, e.g. by email, as soon as practically possible.

6. Prices and Payment Term

6.1 The prices and Other Charges for Services are as agreed in an offer by Vacon accepted by Purchaser, or an order by the Purchaser confirmed by Vacon or in the Contract and are exclusive of VAT and other similar taxes and public charges.

6.2 The Services and Other Charges will be priced based on Vacon's price list, as valid from time to time, in a case there is no written Contract between the Parties or otherwise offered by Vacon.

6.3 Unless otherwise agreed, all prices and costs are subject to change without notice. In the event of a price change, the effective date of the change will be the date of the new price or price list, letter or electronic notification. New pricing will be applied in all quotations made by Vacon and in orders confirmed by Vacon after such effective date.

6.4 Unless otherwise agreed, the Services will be invoiced after the performance of the Services. Payments shall be made within fourteen (14) days from the date of Vacon's invoice. If Products sold to the Purchaser as part of or in connection with Services are invoiced on the same invoice as the Services, the same payment term shall apply to such Products.

6.5 If the Purchaser fails to make any payment in due time, Vacon may, at its discretion, consider the Contract breached, claim all unpaid amounts, claim interest for delayed payment(s) and cancel or suspend any pending performance of Services to the Purchaser. Unless otherwise agreed, the delay interest is fifteen per cent (15 %) per annum, however, not more than the highest permitted interest rate under the mandatory provisions of the applicable law.

7. Liability and Warranty

7.1 Vacon hereby warrants that the Services are performed in a professional manner by a person with adequate experience and expertise for the task. Further, the Services shall fulfil the requirements and characteristics set forth in the Contract. Services are performed by using Vacon's own working methods and instructions.

7.2 Vacon shall not be responsible for any failures in the performance of Services due to the Purchaser's negligence or misuse, modification or rework, combination, incorrect installation, commissioning or maintenance, unauthorized dismantling, abnormal or exceptional working, installation, commissioning or operation conditions, or the Purchaser's failure to adhere to Vacon's instructions and specifications. Neither shall Vacon be responsible for failure to perform the Services if it is not (i) safe for the personnel of Vacon or the Service Provider to carry out the Services at an agreed location or (ii) practically possible due to wear and tear of Products, or the use of spare parts other than those approved by Vacon, or (iii) the Purchaser's failure to ensure information security in the environment where the Services are performed or utilized.

7.3 Vacon's liability for the Purchaser for possible errors, defects or any other shortcomings in the sale or delivery of Services shall be limited in all cases to remedying of such errors according to section 7.4.

7.4 Provided that the Purchaser has notified in writing Vacon (or its Service Provider as provided for in section 7.5 below) of the defect in the performance of Service within five (5) working days after discovery of the defect, not, however, later than after three (3) months from the delivery of the Service in question, Vacon shall, at its discretion, either re-perform the Services or refund the purchase price of the failed Services.

7.5 All communication relating to claims based on Services provided by any Service Provider shall be between the Purchaser and such Service Provider.

7.6 The warranties above in section 7.1 are exclusive and are in lieu of all other warranties, whether written or oral, implied or statutory VACON AND THE PURCHASER HEREBY WAIVE ANY WARRANTY OF MERCHANTABILITY AND WARRANTY OF FITNESS FOR A PARTICULAR USE. Vacon shall not be liable for any other activity and/or cost than those set forth in section 7.4 above.

8. Purchaser's Warranties and Responsibilities

8.1 The Purchaser hereby represents and warrants that it shall comply with all applicable provisions (if any) of the Council Regulations (EC) setting up a Community regime for the control of exports, transfer, brokering and transit of dual-use items, and other applicable control regime as valid from time to time.

8.2 The Purchaser shall deliver the data and materials agreed to be provided by the Purchaser as well as other items in a form following Vacon's instructions.

8.3 The Purchaser shall be responsible for the instructions, data and material provided by it. The Purchaser shall also be liable for the use of such data and materials for the Services performed by Vacon or its Service Provider.

8.4 The Purchaser shall obtain and maintain at all times sufficient general liability and property insurance coverage.

9. Intellectual Property Rights

The sale and delivery of any Services to the Purchaser shall not transfer, confer or grant to the Purchaser any IPR to the Services, Products or related documents, save the right of normal use of related documents in the Purchaser's ordinary business.

10. Service Providers

Vacon shall be entitled, at its sole discretion and at any time to use Service Providers to perform the Services on behalf of Vacon. Vacon shall be responsible for the performance of such Service Providers as for its own. Vacon shall, however, not be responsible for any acts or omissions by such Service Providers under or relating to contracts executed directly by and between the Purchaser and the Service Provider.

11. Force Majeure

11.1 Vacon shall not be liable to the Purchaser for failing to fulfill its obligations as a result of circumstances beyond its reasonable control, including without limitation fire, explosion, accident, strike, lockout, flood, drought, embargo, war (whether declared or not), riot, natural disasters, sudden sickness of a person carrying out the Service in question or acts of the public enemy, action of any governmental authority, general shortage of material or transportation, or the delay or non-performance of a sub-contractor due to the above reasons.

11.2 If it has become evident that the fulfillment of the Contract will be delayed for more than four (4) months due to a force majeure event, each Party shall be entitled to cancel the Contract to the extent it is reasonable, by notifying the other Party thereof in writing without either Party having the right to claim damages.

12. Confidentiality

Each Party shall, during the term of the Contract and thereafter, hold in confidence and not disclose to any third party any Confidential Information which has been disclosed to it by the other Party in connection with the Contract or otherwise learned by it in connection with the delivery of the Services. The Parties shall not use any Confidential Information for any other purpose than for the proper performance of the Contract and the delivery of the Services. The above obligations of confidentiality and non-use shall not apply to Confidential Information which the receiving Party by written records demonstrate (i) was in its possession prior to the first receipt thereof from the disclosing Party, and/ or (ii) which becomes a matter of public knowledge without a breach of the confidentiality obligation hereunder, and/or (iii) which is obtained from a third party under circumstances permitting its disclosure to others.

13. Limitation of Liability

Each Party's maximum liability to the other for damages arising from the sale and purchase of Services shall never exceed the net invoiced value of the relevant Service. In no event shall either Party be liable to the other for loss of production, loss of profits, business, revenue, data or goodwill, cost of capital, losses arising from plant shut down, labor costs or other consequential, incidental, indirect, special or punitive damages.

The aforesaid limitations of liability shall not, however, apply in cases where damages are caused by (i) willful misconduct or gross negligence, or (ii) culpable injury to life, body or health.

14. Severability

The provisions of these General Terms are intended to be severable. If any provision or part thereof is held invalid, then the rest of the General Terms shall remain in full force and effect.

15. Governing Law and Dispute Resolution

15.1 These General Terms as well as any other terms of the Contract shall be governed by the laws of the country/ state in which the contracting Vacon entity is located, without, however, giving effect to the rules on conflict of laws within such jurisdiction. The Vienna (UN) Convention on Contracts for the International Sale of Goods shall not apply.

15.2 Any dispute, controversy or claim arising out of or relating to the Contract, or the breach, termination or validity thereof shall be finally settled by arbitration. The arbitration shall be governed by (i) the Commercial Arbitration Rules of the American Arbitration Association ("AAA") for disputes governed by U.S. law, (ii) the Arbitration Rules of the China International Economic and Trade Arbitration Commission ("CIETAC") for disputes governed by Chinese law, or (iii) by the Rules of Arbitration of the International Chamber of Commerce ("ICC") for disputes governed by any other law than those mentioned above. The place of arbitration shall be Vacon's domicile, and the arbitration shall be conducted in the English language. Notwithstanding the foregoing, (i) Vacon shall, however, be entitled to lodge claims concerning the collection of outstanding debts in any court having jurisdiction over the Purchaser; and (ii) the Parties agree that nothing herein shall be construed to prevent Parties from seeking injunctive relief for immediate and irreparable harm in such circumstances where such equitable relief is necessitated and no immediate adequate remedy at law is available.

16. Amendment of the General Terms

Vacon reserves the right to amend these General Terms by notifying the Purchaser and delivering the amended terms and conditions to the Purchaser before the terms and conditions come into force.

If the Purchaser objects to the entry into force of such amended terms and conditions, the Purchaser shall notify Vacon thereof in writing within fourteen (14) days of the receipt of the amended terms and conditions. In that case the current terms and conditions shall continue to be applied to the Contract between Vacon and the Purchaser and, unless the Parties agree otherwise in writing, the Contract between the Parties shall terminate after thirty (30) days from the receipt of the Purchaser's notification by Vacon.

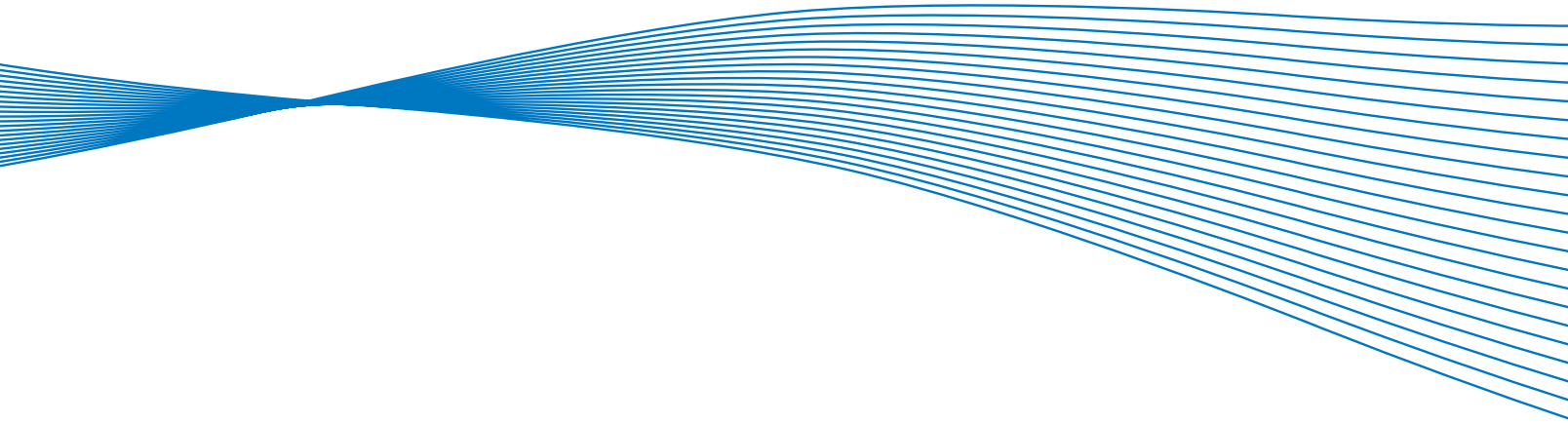

EVERY AC motor
deserves **A VACON DRIVE**

www.vacon.com
1-877-VACON-06
1-877-822-6606

Vacon Partner