

Geniox

Catalogue



This catalogue presents a technical description of the Geniox air handling unit, its components and accessories. Geniox is designed as a modular air handling unit. Each function is placed into an air handling unit casing consisting of one or more modules. It is available in 12 sizes with airflows from 750 to 48,000 m³/h (0.2-13.3 m³/s).

Geniox units are designed in SystemairCAD, a design program which ensures an optimal dimensioning of the unit's functions. When the unit design is finished, SystemairCAD makes a technical calculation and automatically generates a complete technical documentation in pdf format for the selected unit. Download SystemairCAD on Systemair's website.



Contents

Comfort ventilation by Systemair	4
Geniox	6
Geniox, innovative solutions	8
Geniox functions	10
Systemair Access; Complete control system	12
Configure Geniox with SystemairCAD	13
Quick selection of Geniox	14
Directives and certifications	16
Standards	17
Geniox casing	18
Roof unit	20
Pre-painted unit	21
Plug fan	22
Rotary heat exchanger	24
Plate heat exchanger	26
Run-around coil heat exchangers	28
Heating coil	29
Cooling coil	30
Change-over coil	31
Integrated reversible heat pump	32
Air humidifier	34
Panel filter	36
Bag filter	37
Metal filter	38
Carbon filter	39
Damper	40
Sound attenuator	42
Inspection section	43
Empty section	44
Outdoor air section	45
Supporting legs	46
Standard base frame and base frame with high legs	47
Base frame with forklift holes	48
Assembly brackets	49
Duct connection part	50



Comfort ventilation by Systemair

Comfort ventilation describes the ventilation systems most often used in hospitals, hotels, schools, and offices. The purpose of this ventilation system is to create a healthy and comfortable indoor climate. Geniox is designed in flexible modules. This gives you the freedom to choose precisely the features that you need.



As a rule of thumb, ventilation accounts for 40% of a building's energy consumption. That means there is a significant potential for improvement. Geniox aims to exploit that potential and reduce the percentage. Geniox air handling units feature the most energy efficient motors. The unit employs the latest advances in energy recovery technology, and the casing is designed to reduce any energy loss in the process.

The design program SystemairCAD will always inform you of the projected energy class of your chosen unit. In SystemairCAD, you also have the possibility to calculate the lowest energy consumption combined with the best possible fan for VAV operation by applying alternative operating points. SystemairCAD calculations are certified by Eurovent.

- Modular construction.
- Fully customised.
- Freedom of choice.
- Robust design.
- High air tightness.
- High efficiency.
- Easy to select, order, and install.
- Safe and precise delivery.

Geniox



Geniox is designed as a modular air handling unit. Each function is placed into an air handling unit casing consisting of one or more modules. The modular functions can be configured for many different applications to make up the heart of any ventilation system.

- Geniox, modular air handling unit:
12 sizes with airflows 750-48,000 m³/h (0.2-13.3 m³/s).
- With rotary heat exchanger, run-around coil heat exchangers, cross flow heat exchanger, or counter flow heat exchanger.
- Plug fan with EC motor IE5, PM motor IE4, or AC motor IE3.
- Filter classes: Coarse 65% (G4), ePM10 60% (M5), ePM2.5 50% (M6), ePM1 60% (F7), ePM1 75% (F8), ePM1 85% (F9), CITY-FLO ePM1 60% (F7 City-Flo), metal filter (G2) or carbon filter.
- With water heating coil, electric heating coil, and/or cooling coil.
- Can be supplied with integrated heat pump.
- Can be supplied with humidifier/adiabatic cooling.
- With Systemair Access control system, without control system, or Controller Ready.
- For indoor or outdoor installation.
- Eurovent certified.

Geniox airflows

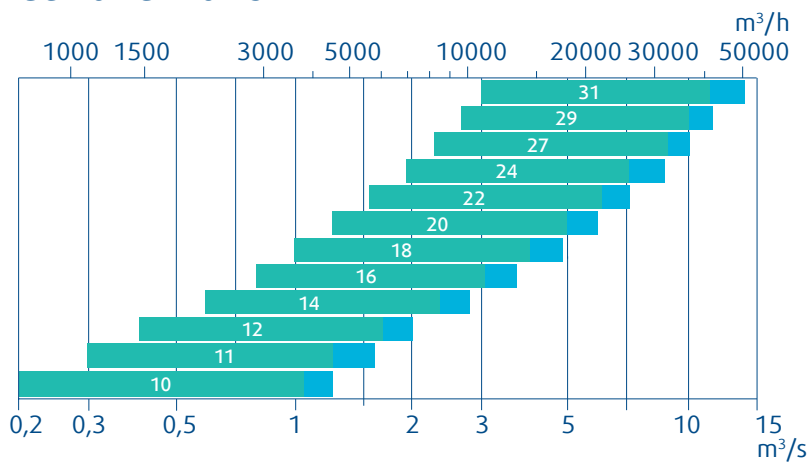

- Airflow range for Geniox complying with Ecodesign.
- Full airflow range for Geniox.

The above airflows are calculated with rotary heat exchanger and EC motors.



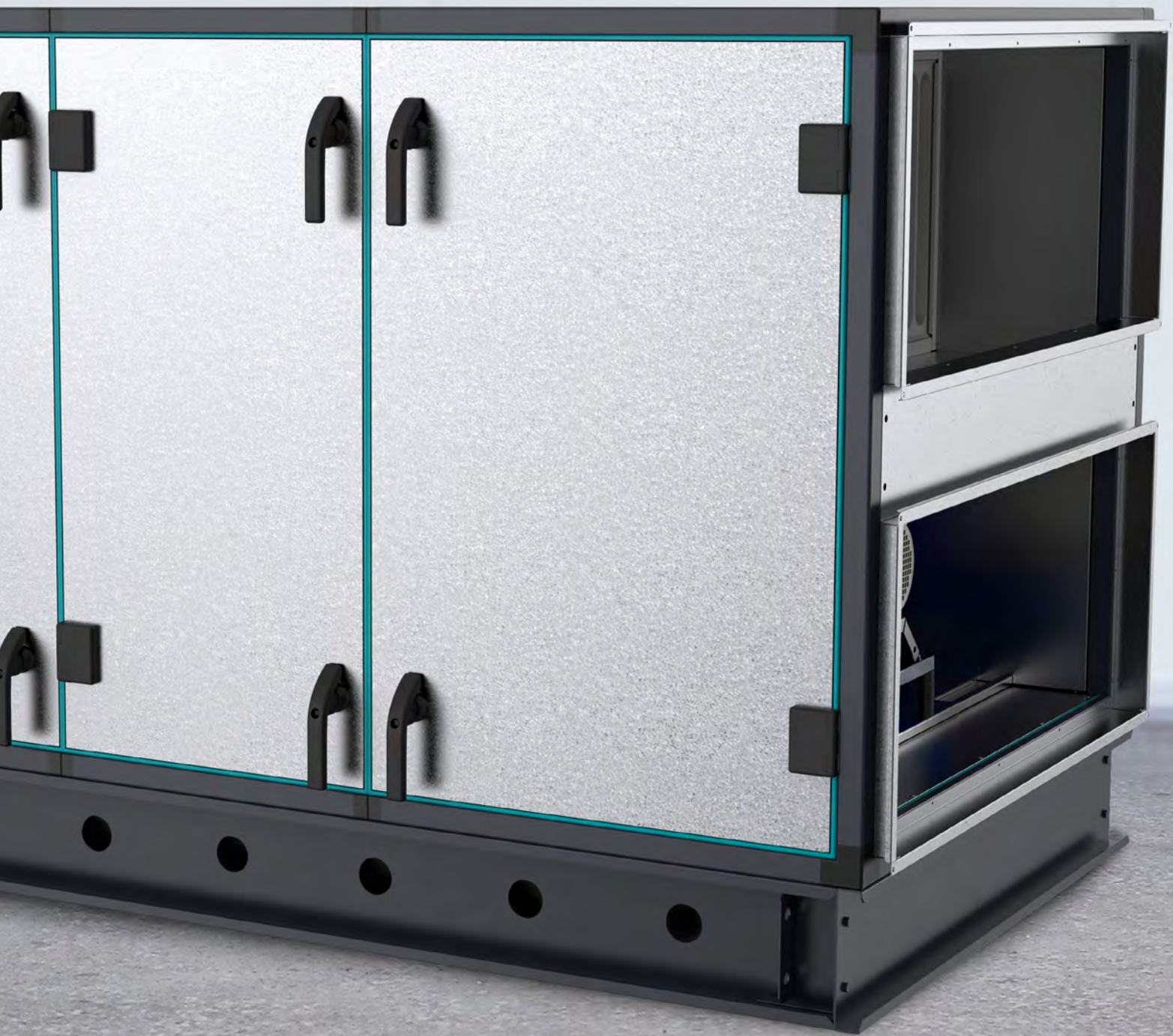

Geniox, innovative solutions



Casing

- Thermal bridging class TB2.
 - Thermal insulation class T2.
 - Deflection class D1.
 - Air leakage class L1.
- Official model box
EN 1886 results.

Panels. Elimination of thermal bridges. Separation between inner sheet and outer sheet (0,8 mm) with 60 mm insulating mineral wool. Density: 60 kg/m³. Aluzinc AZ 185 or pre-painted steel sheets in black RAL 9005 or in light grey RAL 7035 ensure a corrosion protection class C4 according to the standard EN ISO 12944-2:2000.

Frame profiles.

- Corrosion class C4.
- Powder-painted
Z275 galvanized profiles inside, 1,0/1,5 mm.



Handles and hinges. Practical handles and hinges make it possible to take off all doors and provide a space-saving solution that is easy to service.



Inspection windows. The windows have been designed exclusively for Systemair and provide a large area for easy inspection.

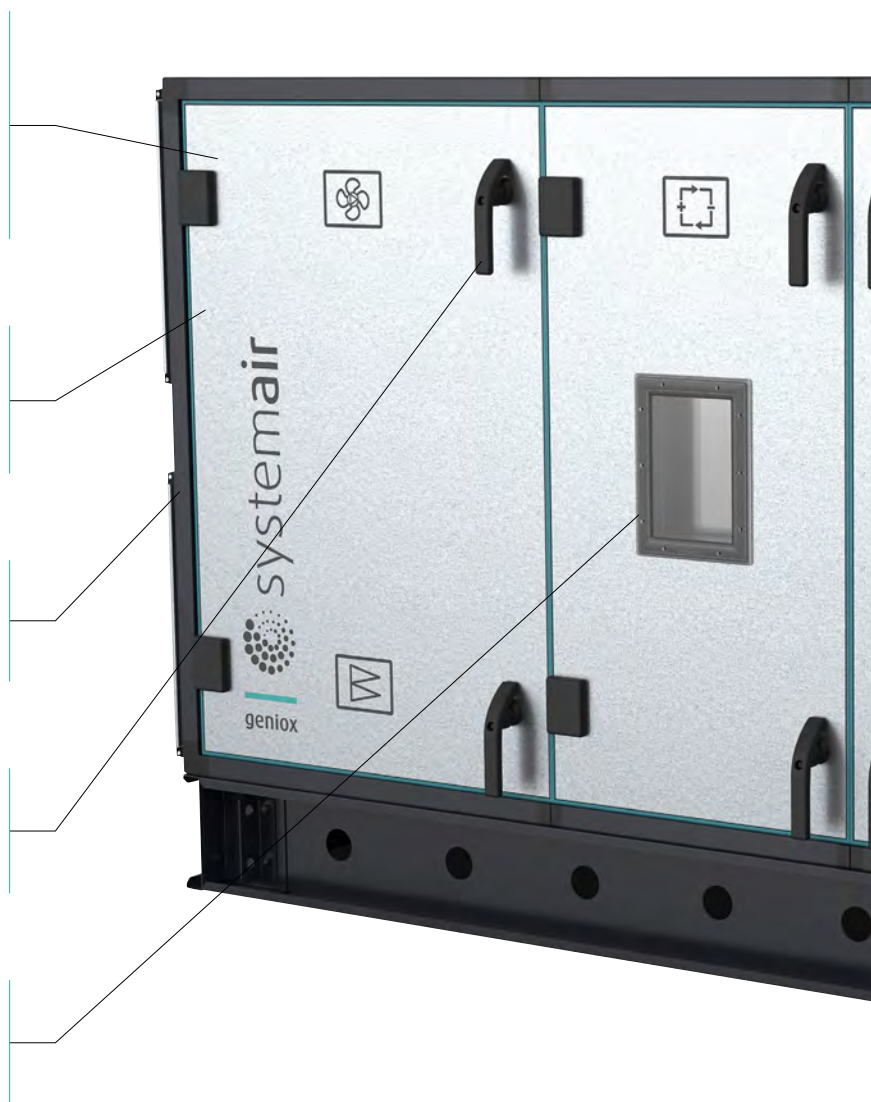



Service and maintenance. All doors provide easy access for cleaning and service.

Transportation. Casing design and standard packaging allows for easy transportation.



Roof unit. Geniox is available as roof unit, designed for outdoor installation. In this version the unit is assembled on a base frame. The roof unit can be delivered with three different types of roof:

Steel profile roof, Aluzinc protected corrugated steel sheets and profiles for fastening and finishing the roof.

Rubber sheeting roof and bitumen membrane roof, very easy to handle and has a good weather protection.

Pre-painted unit. Black RAL 9005 or light grey RAL 7035. Frame profiles in RAL 7024 for both solutions.



Operating pressure

Difference between external and internal pressure:
0 - 2000 Pa.

Operating temperatures

Standard design: -40/+40 °C
Special design: -40/+60 °C.

Directives. Geniox fulfils the following directives:

- Machinery Directive 2006/42/EC
- Ecodesign Directive 1253/2014
- EMC Directive 2014/30/EU
- Low Voltage Directive 2014/35/EU
- Pressure Equipment Directive 2014/68/EU.



Eurovent certification

Geniox is constructed in accordance with European standards and is certified by Eurovent.



Geniox functions

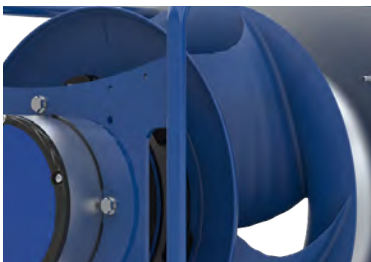

The plug fan has the impeller fitted with air foiled blades to obtain the highest possible efficiency. The fan is a single inlet, free-blowing fan where the unit casing acts as fan housing. The plug fan has a static efficiency of up to

75%. The plug fan can be supplied with EC motor (IE5), PM motor (IE4), or AC motor (IE3). Fan impeller and motor are statically and dynamically balanced.



The rotary heat exchanger is available in three variants: Condensation, sorption hybrid and sorption heat exchanger. Generally, the rotary heat exchanger has a high efficiency from 75% to 87% depending on operating conditions. It can recover moisture and is the heat exchanger that requires the least space. The sorption hybrid exchanger recovers more moisture, and therefore contributes to the humidification of the supply air. The sorption exchanger dehumidifies the air more, making it particularly suitable for dehumidifying the outdoor air, for example before cooling.

avoided. There is no transfer of moisture between the two airflows.

The cross flow exchanger has an efficiency of up to 85% depending on air speed and unit size. It is made of aluminium for comfort.

The counter flow exchanger has a efficiency of up to 90% and is supplied only in aluminium. The heat exchangers are fitted with by-pass for capacity control and for frost protection, and have a built-in drip tray with slope.

The plate heat exchanger is available in two variants: Cross flow and counter flow heat exchangers. Generally, the plate heat exchanger has a high efficiency. It has separated airflows, and thus the transfer of odours to the supply air is

The run-around coil heat exchangers have an efficiency of up to 80% depending on air speed through the coil, and are used, where the two airflows must be kept completely separate, or where the airflows are in different places.



The heating coil is used for heating the supply air. The heating can be effected by hot water or condensation of refrigerant. These coils consist of copper tubes and aluminium fins. Heating can also be effected by electricity. These coils consist of heating elements of stainless steel and have built-in safety control system.

evaporative refrigerant. A cooling coil for evaporation has the liquid distributor placed in the unit. These coils consist of copper tubes and aluminium fins.

The cooling coil is used for cooling the supply air. It can be effected by cold water or direct

The change-over coil is basically a cooling coil for cold water, which can also be used for heating by changing the water temperature from cold to warm as required.

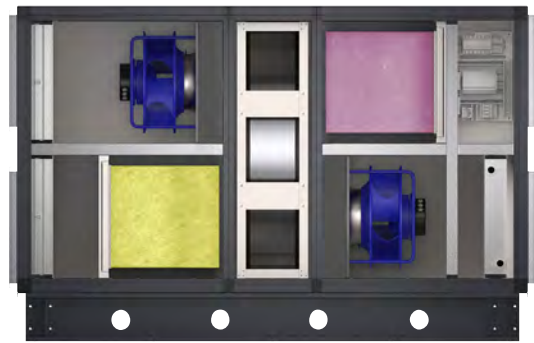

The heat pump is an integrated reversible heat pump system built into a unit section. The system consists of a reversible heat pump and a rotary heat exchanger that enables both heating and cooling. The unit is equipped with scroll

compressors, and cooling/heating capacity is stepless variable in the range 5-100%. The heat pump is based on R-410A refrigerant. The heat pump is equipped with a complete control system.



The humidifier is made as a complete unit, which includes humidification elements, tray and frame made of stainless steel AISI 304, circulation pump, irrigation regulation valves, overflow, bleed-off regulation valve, float valve for controlling the water supply to the tray and valve for emptying the tray. The function of the

humidifier is based on the natural process that water evaporates when air passes a wet surface. The humidifier can either be placed in the supply air after a heating coil or used as indirect adiabatic cooling by placing it in the extract air before a heat exchanger.

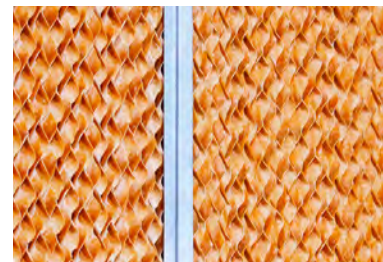

The panel filter is a basic filter class Coarse 65% (G4) according to EN ISO 16890 with a short building length. It is designed on pleated filter principle.

The bag filter is a bag filter, which design provides a large filter area. The filter has a long lifetime and thus good overall economy. The filter can be supplied in the filter classes Coarse 65% (G4), ePM10 60% (M5), ePM2.5 50% (M6), ePM1 60% (F7), ePM1 75% (F8), ePM1

85% (F9), or CITY-FLO ePM1 60% (F7 City-Flo) according to EN ISO 16890. CITY-FLO ePM1 60% is a filter with particle and molecular filtration, specially designed for use in urban areas and areas with heavy traffic. Bag filters are available in 2 lengths; 520 and 640 mm.

Metal filter. Class G2.

Carbon filter. Carbon type CEX003 in a cylindrical cartridge.



The dampers comply with tightness class 4 C according to EN 1751:2014. The dampers have counter rotating aerodynamically shaped damp-

er blades made of aluminium, which ensure a low pressure loss when open.



The sound attenuator is an absorption attenuator with baffles. It is used to reduce the sound power

level from the air handling unit to the duct system. Can be delivered for dry and wet cleaning.

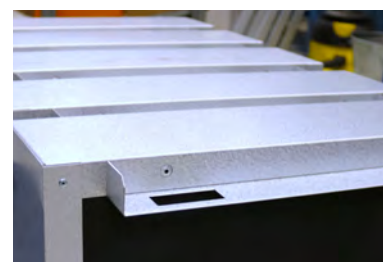



Systemair Access; Complete control system

Systemair Access is the complete control system for Geniox. Access has been developed by Systemair for Geniox air handling units. Access can be controlled with the NaviPad control panel.

We have selected the most important functions for NaviPad to make it simple and user-friendly for you. NaviPad has an intuitive user interface, as you know from your smartphone. It is easy to gain an overview of the Access controller where you can connect all external components.

- The NaviPad control panel has a 7" touch screen.
- We have developed a logical navigation structure, inspired by smartphones.

- Name and connect up to 9 air handling units to the same control panel.
- BMS communication via ModBus, BACnet as well as cloud access to Systemair Connect.
- Dynamic flow chart: Press the function, change the setting and go!
- Quickly and safely connect external sensors to the controller.
- Editable name on external components for better overview.
- Plug and play – prepared for easy start-up and operation.



Download SystemairCAD
from Systemair's website.

Configure Geniox with SystemairCAD

SystemairCAD is a user-friendly design program which ensures an optimal dimensioning of the air handling unit's functions. When the unit design is finished, SystemairCAD makes a technical calculation and automatically generates a complete technical documentation in pdf format for the selected unit.

The documentation includes the following highlights:

- Technical data
- Detailed drawing
- Shipping, dimensions and weights
- Control system description like control functions, flow chart and connection diagrams
- Molliere diagram

- Specification text
- ErP 2018
- LCC calculations.

The drawn to scale drawings from SystemairCAD can be exported to other CAD software and for use in BIM and:

- Export of DXF files 2D and 3D.
- Export of DMR files to Autodesk Revit.
- SystemairCAD project files can be opened directly in AutoCAD via MagiCAD plugin and in Autodesk Revit via Revit plugin.

Quick selection of Geniox

Rotary heat exchanger		Unit size											
		10	11	12	14	16	18	20	22	24	27	29	31
Unit	Width	1082	1182	1282	1482	1682	1882	2082	2282	2482	2782	2982	3182
	Height*	1082	1182	1282	1482	1682	1882	2082	2282	2482	2764	2964	3164
	Length	2282	2282	2282	2282	2282	2282	2382	2464	2464	2946	3146	3146

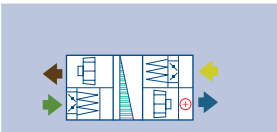

The above dimensions are a guideline only. Accurate values and combinations are calculated in SystemairCAD.
* Height excl. legs/base frame.

Plate heat exchanger Counter flow heat exchanger		Unit size						
		10	11	12	14	16	18	20
Unit	Width	1082	1182	1282	1482	1682	1882	2082
	Height*	1082	1182	1282	1482	1682	1882	2082
	Length	3182	3382	3382	3482	3782	3782	3982

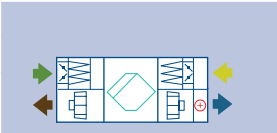

The above dimensions are a guideline only. Accurate values and combinations are calculated in SystemairCAD. * Height excl. legs/base frame.

Design an air handling unit

Geniox contains countless combination options. To ease the process of designing a unit the most popular combinations are illustrated here.

Key to symbols

Exhaust air Extract air
Outdoor air Supply air

Plate heat exchanger Cross flow heat exchanger		Unit size											
		10	11	12	14	16	18	20	22	24	27	29	31
Unit	Width	1082	1182	1282	1482	1682	1882	2082	2282	2482	2782	2982	3182
	Height*	1082	1182	1282	1482	1682	1882	2082	2282	2482	2764	2964	3164
	Length	2982	3082	3182	3382	3582	3782	3782	4446	4746	4946	5446	5446

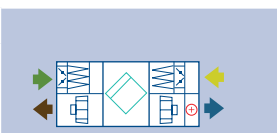

The above dimensions are a guideline only. Accurate values and combinations are calculated in SystemairCAD.
* Height excl. legs/base frame.

Integrated reversible heat pump		Unit size								
		10	11	12	14	16	18	20	22	24
Unit	Width	1082	1182	1282	1482	1682	1882	2082	2282	2482
	Height*	1082	1182	1282	1482	1682	1882	2082	2282	2482
	Length	3282	3282	3282	3282	3482	3482	4082	4346	4546

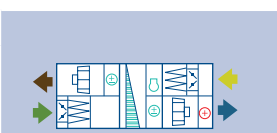

The above dimensions are a guideline only. Accurate values and combinations are calculated in SystemairCAD.
* Height excl. legs/base frame.



Directives and certifications



Eurovent certification

Geniox air handling units are Eurovent certified. This ensures the conformity between the calculated performance in SystemairCAD design program, and the measured performance at independent test laboratories. Certificate 17.07.012.

Eurovent energy classification

Geniox air handling units are energy classified according to Eurovent's guidelines for air handling units. The energy class expresses the unit's total energy consumption. The energy class is calculated by the design program SystemairCAD based on the actual data of the designed unit.

Ecodesign Directive

The Ecodesign Directive 1253/2014 prescribes minimum requirements regarding heat recovery efficiency, fan efficiency, SFP internal values, and operation of the air handling unit. The selection software SystemairCAD is updated with an automatic Ecodesign calculation that will tell you if the requirements for 2018 are fulfilled.

Machinery directive

Geniox air handling units are manufactured according to the safety demands of the EU Machinery Directive 2006/42/EC. This is confirmed through the issuance of corresponding Declaration of Conformity and CE label.

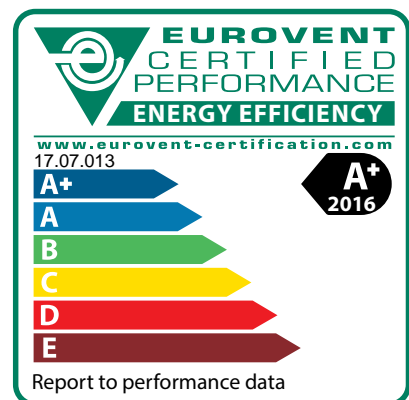
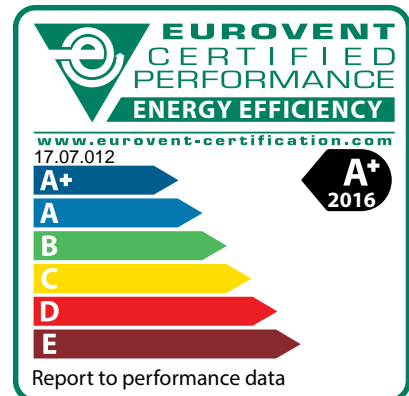



Standards

The Geniox design is based on the demands in the following CEN and ISO standards:

EN 305:1997

Heat exchangers. Definition and test procedures.

EN 308:1997

Heat exchangers. Test procedures.

EN 378-1&2:2016

Refrigerating systems and heat pumps safety and environmental requirements.

EN ISO 16890

Air filters for general ventilation.

EN 1216:1999

Heat exchangers.

EN 1751:2014

Aerodynamic testing of dampers and valves.

EN 1886:2008

Air handling units.
Mechanical performance.

EN 13053:2011

Ratings and performance for units and components.

EN 13779:2007

Ventilation for non-residential buildings. Performance requirements.

EN 60204-1:2006

Machine safety.
Electrical equipment of machines.

EN ISO 3741:2010

Determination of sound power level in reverberation rooms.

EN ISO 5136:2009

Determination of sound power level in a duct.

EN ISO 12100:2011

Safety of machinery.

EN ISO 12944-2:2000

Corrosion protection.
Classification of environments.

DS 428

Danish Standard for fire technical precautions, indoor air handling units comply with class A2-s1,d0.

Geniox casing

Air handling unit casing

The casing protects the inside functions and is very effective for thermal and sound insulation.

Thermal insulation

Class T2. Sound and thermal insulating mineral wool, which is completely encapsulated between two steel sheets. Thickness: 60 mm. Density: 60 kg/m³.

Thermal bridging factor

Class TB2.

Acoustic insulation of casing

Octave band Hz	Insulation dB
125	14
250	25
500	27
1000	26
2000	28
4000	30
8000	41

Deflection

Class D1.

Air leakage

L1.

Mechanical performances are the results of official model box test (EN 1886).

Operating pressure

Difference between external and internal pressure:
0 - 2000 Pa.

General temperatures

General temperatures for air in the air handling unit:
Standard design: -40/+40 °C
Special design: -40/+60 °C.



Frame profiles and corners. Geniox is constructed using a framing profile, 1,0/1,5 mm. The frame profiles are made of Z275 galvanized profiles inside and externally powder-painted. The result is a strong and robust construction

able to resist twisting and lateral movement, making the unit extremely stable and strong. The design of the corners is ABS which ensures minimal thermal bridging.



Panels. The panels of Geniox are built using a sandwich construction with double sheets and 60 mm mineral wool for sound and heat insulation. The mineral wool is completely encapsulated, since the panels are closed on all sides. The panels with Aluzinc AZ 185 surface are not only highly corrosion-resistant, but present an attractive, uniform appearance that can last for

many years. The panels are also available as pre-painted steel sheets in black RAL 9005 or light grey RAL 7035. The frame profiles are always pre-painted in RAL 7024. The Aluzinc AZ 185 and the pre-painted steel sheet ensure a corrosion protection in class C4 according to EN ISO 12944-2:2000.



Handles and hinges. Practical handles and hinges make it possible to disassemble all doors and provide a space saving solution that is easy to service. All doors will have one handle with a lock. Doors with 2 handles: Lock placed in top

handle. Doors with 3 handles: Lock placed in middle handle. Doors with 4 handles: Lock placed in one of the middle handles. Stacked air handling unit: The lock will be placed in the bottom handle of the top doors.



Filter by-pass leakage

Class F9 according to EN 1886.

Free area in front of and above the unit

When positioning the unit, we recommend that an area in front of the inspection side with the same width as the unit is kept free for

service and inspection and also for replacement of fans, heat exchanger, and coils, if needed.

For safe access to the cabinet with electrical components, if placed on top of the unit, the free area from the upper edge of the cabinet to the ceiling must be at least 700 mm.



Inspection windows. The windows have been designed exclusively for Systemair and provide

a large area for easy inspection.

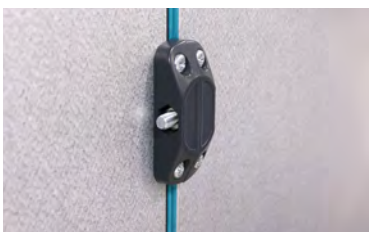

Assembly brackets. A Geniox air handling unit consisting of several sections can be quickly and

efficiently assembled by using the assembly brackets on the outside.



Inspection doors. Geniox has large inspection doors, making service access easy. The doors are mounted using solid hinges with easily removable pins. This means that the doors can be easily removed, if there is no room for nor-

mal opening of the doors. The doors are sealed using rubber profiles and have heavy-duty handles with minimum 1 lock on each door. They can only be locked and unlocked using a key.



Roof unit

The Geniox air handling unit is available as a roof unit for outdoor installation.

Function

For the outdoor installation the unit is assembled on a base frame and features a roof construction which together with the double sealing of the panels provides protection against the effects of the weather.

The roof unit can be delivered with three different types of roof:

Bitumen membrane roof

Manufactured of polyester, reinforced bitumen material fitted to the unit by a heating process. The bitumen roof is a very close and robust roofing completely finished from factory.

Rubber sheeting roof

Manufactured of rubber fitted to the unit by a glueing process. The rubber roof is a very tight and robust roof completely finished from factory. The colour of the rubber roof is light grey.

Steel profile roof

Manufactured of Aluzinc protected, corrugated steel sheets, and profiles for fastening and finishing the roof. This type of roof is supplied for local assembly on the air handling unit. The steel profile roof is a robust roof.

Air intake and exhaust are available with louvers for effective protection against rain and snow. We recommend placing the exhaust air on the back of the unit by adding an outdoor air section. Exhaust can also be placed above air intake in the end of the unit.



Pre-painted unit

The Geniox air handling unit is available with black or light grey pre-painted steel sheets.

Function

The black variant of Geniox is especially suitable for outdoor units when a good blending in with a dark facade and dark roof is required. The light grey variant is well-suited for both indoor and outdoor installation with a fine and even look.

Variants

The sheets are made of pre-painted galvanized steel sheets in black (RAL 9005, gloss 30) or light grey (RAL

7035, gloss 30). When ordering air intake and outlet with louvers these are also painted in black (RAL 9005, gloss 30) or light grey (RAL 7035, gloss 30).

When choosing rubber sheeting roof or bitumen membrane roof, the roof lining will also be in black or light grey.

The frame profiles and corners will be delivered in RAL 7024 as standard for both solutions. The baseframe can be delivered in RAL 7024 for both solutions.

For all variants of the Geniox unit apply that they all come with green panel gaskets. Duct connections will not be painted.

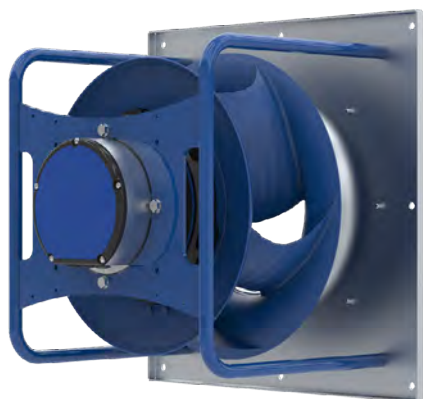

EC Bluefin plug fan.

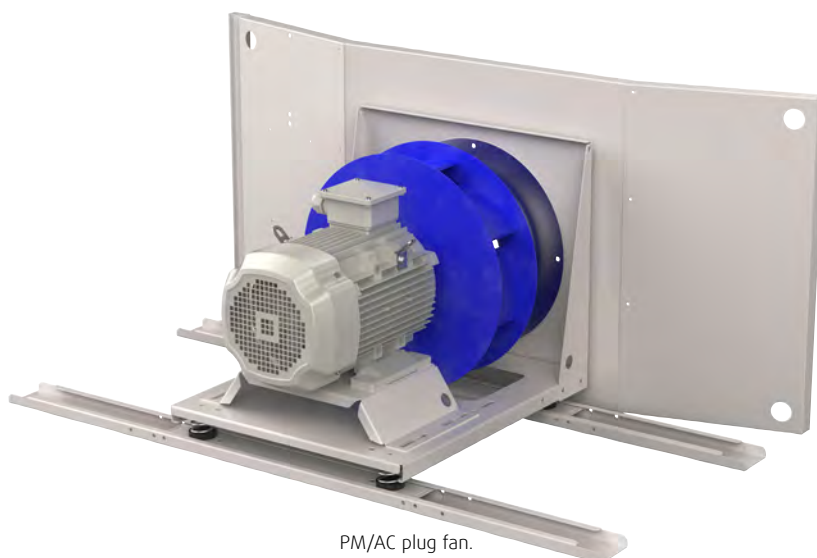

PM/AC plug fan.

Plug fan

The plug fan is built into an acoustically insulated air handling unit.

Construction

Single inlet plug fan with open outlet into the air handling unit. The fan impeller is fitted directly to the motor. Static efficiency up to 75%. To optimise the plug fan efficiency in the operating point, the fans can be selected in several variations:

- S: Low airflow
- M: Medium airflow
- L: High airflow.

Variants

The plug fan comes in two variants:

EC Bluefin

Compact plug fan with an effective composite impeller, where all details are optimised in order to achieve a high efficiency. The impeller is fitted directly to an EC external rotor motor with integrated variable speed control. The EC motor is in efficiency class IE5. An EC motor is characterized by a high efficiency and excellent control features. Several fans can be positioned in parallel operation at larger units. The fans are mounted on the end wall of the fan section.

PM/AC

Plug fan with an effective impeller fitted to the motor shaft. Depending on size, the impeller is made of composite material or painted steel. PM and AC motors are stepless controllable via frequency converter. Two fans can be positioned in parallel operation at larger units. The fans are mounted on vibration steel springs on the bottom of the fan section.

The PM/AC fan can be supplied with two types of motors for 3 x 400 V AC:

PM: Permanent magnet – synchronous motor. Efficiency class IE4 according to EN 60034-31. The motor has a very high efficiency. The rotor is made of magnetic material, which eliminates the slip and reduces heat generation and losses in the motor. Two frequency converters with the same control signal control parallel operation of twin fans.

AC: Induction – asynchronous motor. Efficiency class IE3 according to EN 60034-30:2009. One frequency converter controls parallel operation of twin fans.

Positioning in the air handling unit

A plug fan supplies air at the fan section outlet with a low and even air speed. Therefore, it is an advantage to position air handling components on the outlet side of the fan.

Service-friendly

The plug fan has a large inspection door providing easy access for service. The plug fan PM/AC in sizes 10-14 has the fan and motor assembled on guide rails, which allow easy extraction from the unit.

Sound data

The design program SystemairCAD calculates the fan sound power level L_w (ref. 1 pW). The calculations are based on measurements carried out according to the following standards:

- EN ISO 5136:2009, Determination of sound power level in a duct.
- EN ISO 3741:2010, Determination of sound power level in reverberation rooms.

SystemairCAD also calculates the sound power levels for all duct connections to the unit.

Balancing

The fan is balanced both statically and dynamically.

Operating temperatures

Temperature range: -10/+40 °C.

Airflow calculation

The inlet cone is equipped with a pressure nozzle. This can be used to determine the current airflow using the K-factor and the formula:

$$V = \sqrt{\Delta P_m} \times K$$

V = Airflow in m³/h

ΔP_m = Measured pressure in Pa (according to sketch)

K = K-factor for the current fan (according to table).

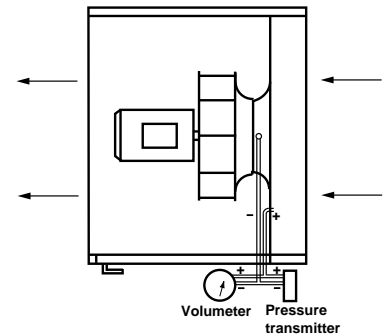

Plug fan EC Bluefin

Impeller ø mm	Material	K-factor	Fan type EC Bluefin
250	Composite	67	10-S, 11-S
280	Composite	85	10-M
310	Composite	106	10-L, 11-M, 12-S
350	Composite	140	11-L, 12-M, 14-S
400	Composite	180	12-L, 14-M, 16-S
450	Composite	220	14-L, 16-M, 18-S
500	Composite	280	16-L, 20-S
560	Composite	355	18-M, 20-M, 22-S
2 x 450	Composite	440	18-L, 20-L, 22-M, 24-S
2 x 500	Composite	560	27-S
2 x 560	Composite	710	22-L, 24-M, 27-M, 29-S
3 x 500	Composite	840	24-L, 27-L, 29-M, 31-S
3 x 560	Composite	1065	29-L, 31-M
4 X 500	Composite	1120	31-L

Plug fan PM/AC

Impeller ø mm	Material	K-factor	Fan type PM/AC
220	Steel	47	10-S
250	Composite	60	10-M, 11-S
280	Composite	75	10-L, 11-M
310	Composite	95	11-L, 12-S
350	Composite	121	12-M, 14-S
400	Composite	154	12-L, 14-M, 16-S
450	Composite	197	14-L, 16-M, 18-S
500	Composite	252	16-L, 18-M, 20-S
560	Composite	308	18-L, 20-M, 22-S
2 x 450	Composite	394	20-L
630	Composite	381	22-M, 24-S
2 x 500	Composite	504	22-L, 24-M, 27-S
2 x 560	Composite	616	24-L, 27-M, 29-S
2 x 630	Composite	762	27-L, 29-M, 31-S
2 x 710	Steel	980	29-L, 31-M
2 x 800	Steel	1240	31-L



Rotary heat exchanger

Regenerative heat exchanger with high efficiency.

Versions

The rotary heat exchanger is available in 4 versions:

- **A:** Low pressure drop
= standard efficiency
- **B:** Normal pressure drop
= normal efficiency
- **C:** Medium high pressure drop
= medium high efficiency
- **D:** High pressure drop
= high efficiency

Variants

The rotary heat exchanger is available in 3 variants: Condensation, sorption hybrid, and sorption heat exchanger.

ST - Condensation heat exchanger:

Winter: This variant is mainly used for recovery of heat from the extract air. However, there may also be recovered moisture from the extract air through condensation at low outdoor temperatures.

Summer: Recovery of cooling energy from the extract air. Available in version: A, B, C, and D.

SH - Sorption hybrid exchanger:

Winter: This variant has a hygroscopic surface so that recovery of heat and moisture is possible before condensation. In this way, high extract air enthalpy content can contribute to the heating and humidification of the supply air.

Summer: Recovery of cooling energy from the extract air and light dehumidification of outdoor air before cooling. Available in version: A, B, and D.

HM - Sorption heat exchanger:

Winter: Recovery of heat and moisture from the extract air. In this way, high extract air enthalpy content can deliver a large contribution to the heating and humidification of the supply air.

Summer: Recovery of cooling energy from the extract air and dehumidification of outdoor air before cooling. Large power savings for cooling can be achieved hereby as less energy is required for condensation loss on the cooling coil. Available in version: A, B, C, and D.

Rotor

The rotor is made with a hub with bearings and two layers of aluminium. The first layer is smooth and the second is corrugated. The two layers are rolled up to the required outer diameter, and then fixed in a very stable construction. The height of the corrugation determines the pressure drop as well as the mass of the rotor and thus also the efficiency. Foil width is 200 mm.

Sealing

In order to safeguard against leakage between the airflows, the heat exchanger is fitted with highly effective brush type seals.

Service-friendly

The heat exchanger is equipped with a large inspection door. The exchangers in sizes Geniox 10 to 16 can be pulled out for inspection.

Division of large heat exchangers

On account of transport the exchangers from size 22 can be supplied divided in the height.

The lower half of the exchanger and the hub of the rotor are assembled into the lower half of the AHU casing. All other parts of the heat exchanger are supplied for local assembly.

Purging sector

The exchanger is with a purging sector that flushes the rotor matrix with outside air before it rotates into the supply air duct. In this way only outside air is present in the matrix, and the carry over of exhaust air to supply air is minimised.

Drive system

An electronic control unit and a slow rotating motor drive the exchanger. This provides an accurate and stepless regulation of the rotor speed. In this way the exchanger efficiency is controlled. The drive system can also be set up for constant speed. In this way the exchanger provides full heat recovery when it is in operation.

Mains connection

1 x 230 V, 50/60 Hz.

Operation indication

The control unit has a LED that indicates the actual operating situation.

Control signal

The control unit can be regulated by an external 0-10 VDC control signal. For

condensation and sorption hybrid heat exchanger 0-10 V corresponds to 0-12 rpm, and for sorption heat exchanger to 0-20 rpm.

Alarm connections

Built-in relay for connection to an alarm system. By an undesirable operating situation an alarm is triggered.

Protection

Built-in protection against unstable voltage supplies from the mains. Built-in overcurrent protection, which protects the motor against overloading.

Rotary alarm switch

Built-in system for monitoring the rotor operation position. Gives a signal by way of an alarm connection, if the rotor operation is interrupted unintentionally.

Purging

Outside of the normal operating period the rotor is turned slowly 12 sec. every 15 min. in order to purge the rotor with clean air.

Cooling recovery

The heat exchanger can be activated for the recovery of cooling energy via the external control signal.

Direction variants

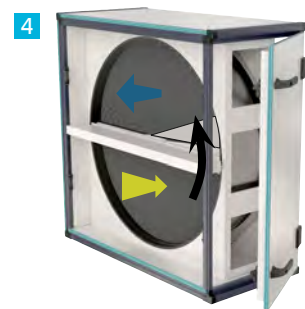
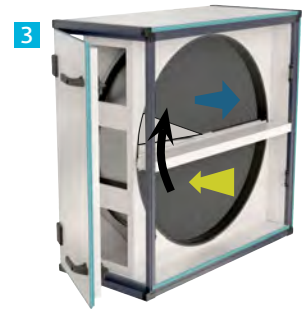
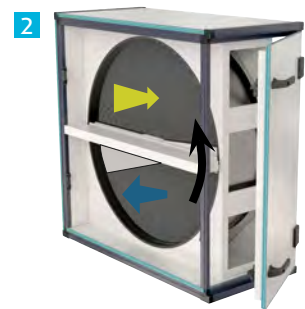
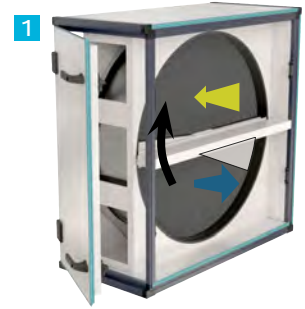

Supply air ← → Extract air

Data for rotor drive system, condensation and sorption hybrid exchangers

Unit size	Type	Motor		Control unit			
		Torque, Nm	Power, W	Type	Voltage, V	Current, A	Max. fuse
10-18	90 TYD-M	2,8	85	RHC 200	1 x 230	0,4	10 A
20-31	120 TYD-M	5,5	145	RHC 200	1 x 230	0,6	10 A

Data for rotor drive system, sorption heat exchanger

Unit size	Type	Motor		Control unit			
		Torque, Nm	Power, W	Type	Voltage, V	Current, A	Max. fuse
10-14	90 TYD-M	2,8	85	RHC 200	1 x 230	0,4	10 A
16-22	120 TYD-M	5,5	145	RHC 200	1 x 230	0,6	10 A
24-31	120 TYD-L	7,5	370	RHC 200	1 x 230	1,6	10 A

Mains electrical connection must not be cut-off outside the normal operating period, as this will terminate the purging function.

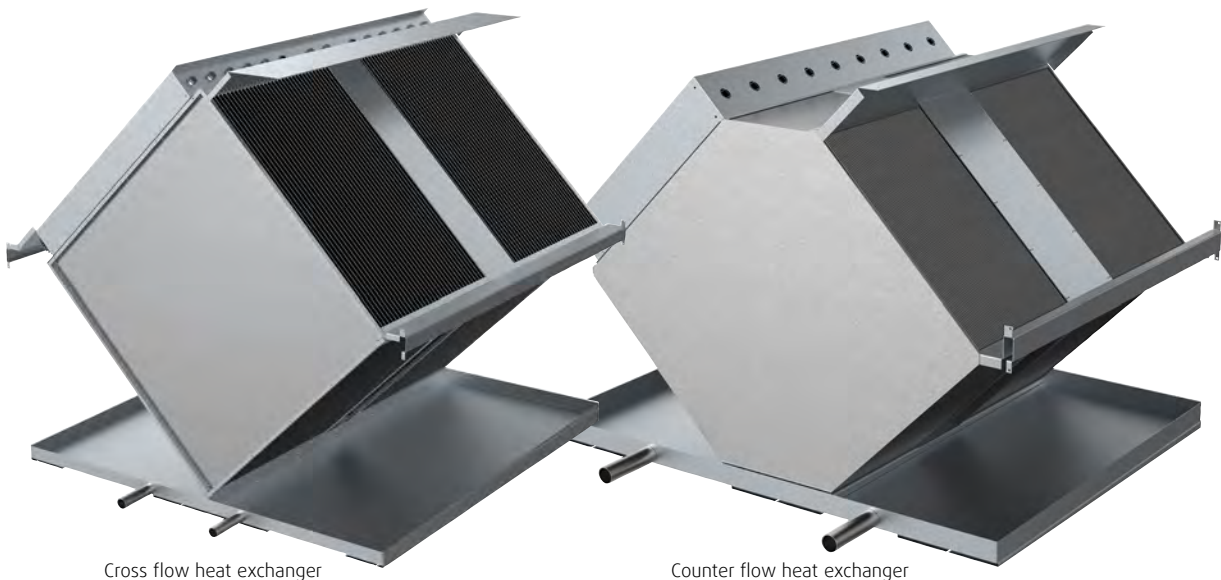

Cross flow heat exchanger

Counter flow heat exchanger

Plate heat exchanger

Recuperative plate heat exchanger with high efficiency.

Application

The plate heat exchanger is used where there are special requirements for separation of the two airflows, e.g. in order to avoid transfer of odours to the supply air. The heat exchangers are made of seawater resistant aluminium for use in environments where no corrosive elements are present in the air to corrode aluminium

Variants

- Cross flow heat exchanger (x).
Unit sizes 10-31.
Efficiency of up to 85%, depending on heat exchanger version and on operation conditions.
- Counter flow heat exchanger (c).
Unit sizes 10-20.
Efficiency up to 90%, depending on operating conditions.

Versions

The cross flow heat exchanger (x) is available for Geniox 10-31 in 4 versions with different distances between the plates. This assures numerous options when dimensioning efficiency and pressure drop of the heat exchanger and therefore great flexibility when adjusting the heat exchanger. Is also available in a corrosion protected version.

By-pass

The heat exchanger is supplied with a built-in by-pass that can regulate the heat recovery from 0-100%. The by-pass function is comprised of a damper for the heat exchanger and a damper for the by-pass airway. The by-pass function is located in the middle of the plate heat exchanger. Consequently, the heat exchanger is divided.

Service-friendly

The heat exchanger is equipped with large inspection doors that provide

access for inspection and service. As the heat exchanger has no rotating part, it requires very little service.

De-icing

If the outdoor air is very cold, usually below $-5\text{ }^{\circ}\text{C}$, there is a risk of frost and ice accumulation in the exhaust air side of the exchanger. By regulating bypass dampers the exchanger can automatically defrost and prevent ice accumulation.

Drip tray with slope

A drip tray made of stainless steel or Aluzinc AZ 185. is fitted beneath the heat exchanger for collection of the water that can condense. The drip tray drain outlet must be fitted with two water traps that are designed for the actual pressure difference. Refer to the assembly instructions. Both heat exchangers are fitted with a drip tray with slope in both extract and supply air sections (40 mm outlet).

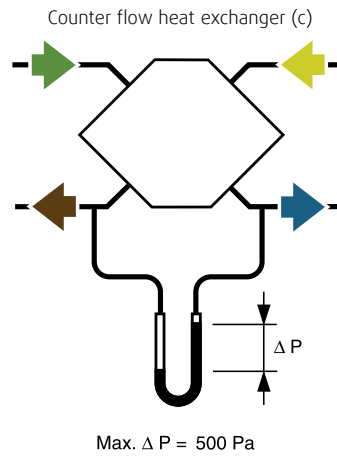
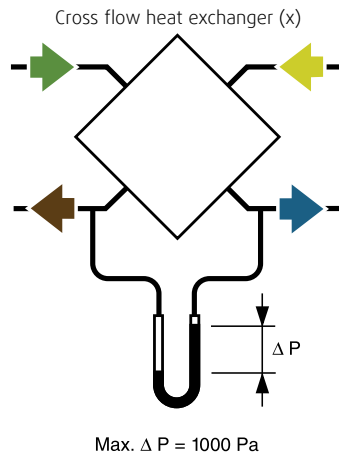

Air direction variants
Extract air, diagonal downstream

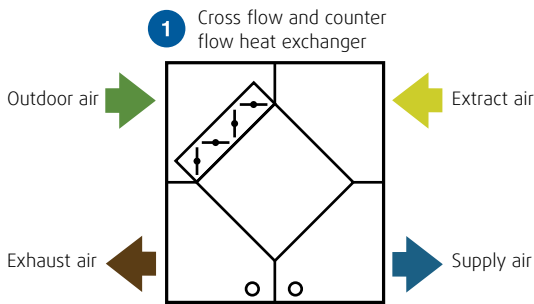

Air direction variants
Extract air, diagonal upstream *

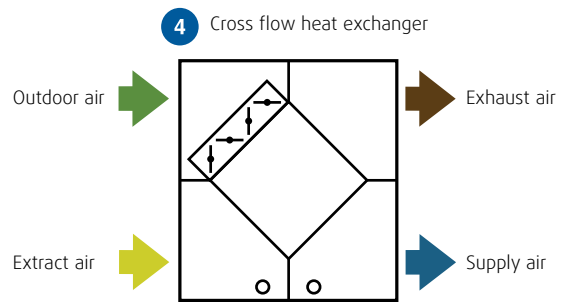
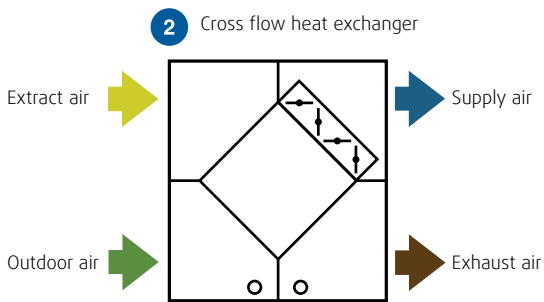
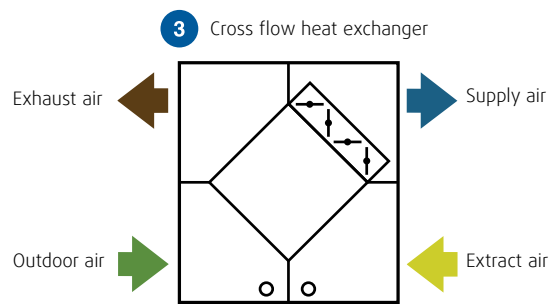

* Air directions with upstream extract air (3 and 4) should only be used when the moisture content of the extract air, before the heat exchanger, is less than the following values:

Supply air before heat exchanger °C	0	-10	-20	-30
Extract air before heat exchanger max. g water/kg air	10	8	6	4

Otherwise, there is a risk of water accumulating in the heat exchanger.

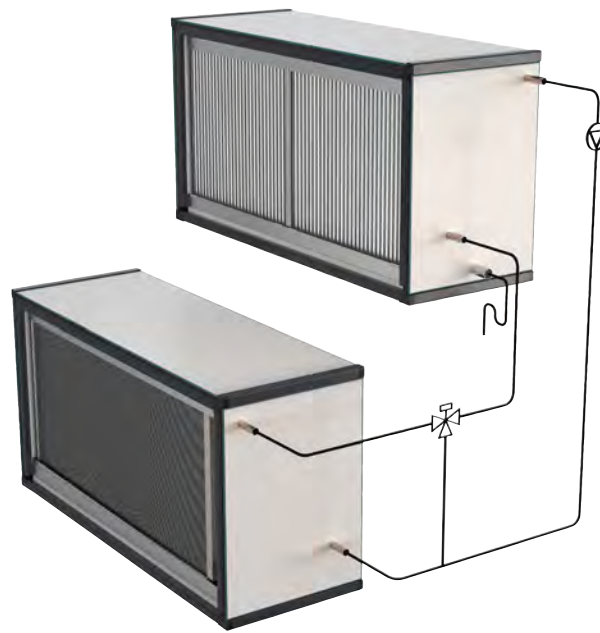

Run-around coil heat exchangers

Heat exchanger system using two water coils to transfer via pipe system the cold/heat between extract and supply units.

Application

The run-around coil heat exchangers are used where it is a requirement that the two airflows must be kept completely separated, or where they are at a distance from each other. The coils must be connected with a piped circuit in which a water/glycol mixture is circulated. Efficiency $\geq 70\%$.

Variants

Standard – Coil completely built into the unit.

MAX – Full size coil which is wider than the unit. Fins surface corresponds to the inside cross section area of the air handling unit.

Construction

The heat exchanger coils consist of copper tubes with aluminium fins.

Copper tubes

Z – Copper tubes $\varnothing 10$ mm. Used for lower capacity heat exchangers.

Y – Copper tubes $\varnothing 15$ mm. Used for higher capacity heat exchangers.

Fins

Al – Standard aluminium.

Alup – Aluminium with a synthetic coating. Used for mildly corrosive air.

Drip tray with slope

In the extract air section a tray for collection of condensed

water is standard. In the supply air section it is an option. The tray is available in stainless steel and in Aluzinc AZ 185. The drip tray drain outlet must be fitted with a water trap that is designed for the actual pressure difference (40 mm outlet). Refer to the assembly instructions.

Droplet eliminator

The run-around coil heat exchangers are available with a droplet eliminator in the extract air section.

Regulation

A motorised valve built into the pipe circuit regulates the heat exchanger capacity.

Piped circuit example

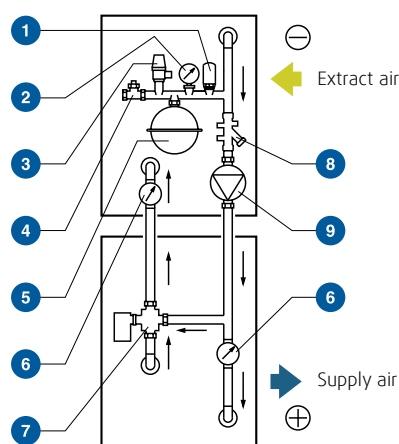

1. Air vent
2. Manometer
3. Safety valve
4. Feed valve
5. Pressure expansion
6. Thermometer
7. Motorised valve
8. Flow measuring valve
9. Pump



Heating coil

Air heater

Heating media

W – Hot water.

Max. temperature 100 °C,
max. working pressure 10 Bar.

Available for temperatures up to
130 °C.

C – Condensation of refrigerant.

Max. working pressure depending
on the type of refrigerant.

E – Electrical heating.

Variants

Standard – Heating coil completely
built into the unit.

MAX – Heating coil which is wider
than the unit, i.e. full-size coil. Hot
water and condensation coils only.

Construction

Water coils and condensation coils
are made of copper tubing and
aluminum fins. Coils for electrical
heating consist of stainless steel
tube heating elements.

Copper tubes

Z – Copper tubes \varnothing 10 mm. Used for
lower capacity heating coils.

Y – Copper tubes \varnothing 15 mm. Used for
higher capacity heating coils.

Fins

Al – Standard aluminium.

Alup – Aluminium with a synthetic
coating. Used for mildly corrosive air.

Frost protection

Heating coils for hot water are
available with a connection piece for
the fitting of a temperature sensor
in the water circuit.

Electrical heating

The inspection door, which can be
opened only by using a key, provides
access to a terminal box for the
electrical connections. The coil has
a built-in safety thermostat with
an automatic reset function and an
overheating thermostat with manual
resetting.



Cooling coil

Air cooler

Cooling media

W – Cold water.

Max. working pressure 10 Bar.

D – Evaporation.

Max. working pressure depending on the type of refrigerant.

Variants

Standard – Cooling coil completely built into the unit.

MAX – Cooling coil which is wider than the unit, i.e. full-size coil to increase surface area and lower pressure drop. Connection on the outside.

Construction

The water coils are made of copper tubing and aluminum fins.

Copper tubes

Z – Copper tubes $\varnothing 10$ mm.

Used for lower capacity cooling coils.

Y – Copper tubes $\varnothing 15$ mm.

Used for higher capacity cooling coils.

Fins

Al – Standard aluminium.

Alup – Aluminium with a synthetic coating. Used for mildly corrosive air.

Pipe connections

The connection pipes for the cooling coil are placed outside of the air handling unit. The cooling coil for evaporation has the liquid distributor placed inside the unit section. The

expansion valve can be fitted to the connection piece outside of the unit.

Drip tray with slope in 3 directions

The cooling coil section is fitted with a stainless steel or Aluzinc AZ 185 drip tray with slope for collection of condensed water. The drip tray drain outlet must be fitted with a water trap that is designed for the actual pressure difference ($\varnothing 40$ mm outlet). Refer to the assembly instructions.

Droplet eliminator

The cooling coil is available with a droplet eliminator that prevents condensed water droplets from being carried into the airflow.



Change-over coil

Heating of air with hot water/glycol. Cooling of air with cold water/glycol.

Heating/cooling media

W – Hot/cold water.

Max. working pressure 10 Bar.

Variants

Standard – Heating/cooling coil completely built into the unit.

MAX – Heating/cooling coil which is wider than the unit, i.e. full-size coil to increase surface area and lower pressure drop.

Construction

Water coils are made of copper tubing and aluminum fins.

Copper tubes

Y – Copper tubes \varnothing 15 mm

Z – Copper tubes \varnothing 10 mm.

Fins

Al – Standard aluminium.

Alup – Aluminium with a synthetic coating. Used for mildly corrosive air.

Pipe connections

The connection pipes for the cooling coil are placed outside of the air handling unit.

Drip tray with slope

The cooling coil section is fitted with a stainless steel or Aluzinc AZ 185 drip tray with slope for collection of condensed water. The drip tray drain outlet must be fitted with a water trap that is designed for the actual pressure difference (\varnothing 40 mm outlet). Refer to the assembly instructions.

Droplet eliminator

The change-over coil is available with a droplet eliminator that prevents condensed water droplets from being carried into the airflow.

Frost protection

The heating/cooling coil is available with a connection piece for the fitting of a temperature sensor in the water circuit.



Integrated reversible heat pump

The integrated heat pump system is built into a unit section. The system consists of a reversible heat pump and a rotary heat exchanger that enables both heating and cooling. The heat pump system can be supplied for Geniox 10 to 24.

Ready for operation at delivery

The integrated heat pump system is supplied as a complete unit that is ready for operation immediately after installation, as it is configured and tested from the factory. The installation is very simple, as the heat pump system is placed between the unit sections and connected to power supply and control signals as well as condensate drain. The integrated heat pump system is equipped with complete control system, which controls the safety functions and capacity regulation. The control system can communicate both with Systemair Access control system and other control solutions.

Construction

The integrated heat pump system is constructed with a 4-way reversing valve so that the system can heat or cool the supply air. Additionally, a rotary heat exchanger is built-in for efficient heat recovery. The

combination of heat pump and rotary heat exchanger ensures excellent operating economy in both heating and cooling situations. The integrated heat pump system is equipped with two scroll compressors (1 compressor for Geniox 10 and 11). The capacity is controlled through the modulating digital function on one of the scroll compressors.

Capacity control

The capacity of the integrated heat pump system can be controlled between 5-100% via a 0-10 V DC signal from the air handling unit's control system. In addition, the control system controls the cooling recovery with the rotary heat exchanger when cooling is required. The outdoor air is cooled by the rotary heat exchanger when the temperature of the extract air is lower than the temperature of the outdoor air. In cooling mode, heat is discharged from the compressor

system via the condenser in the exhaust air after the rotary heat exchanger.

Refrigerant

Type R-410A.

Electrical connection

- 3 x 400 V + N + PE.
- Start/stop signal.
- Heating/cooling mode signal.
- 0-10 V DC for capacity control.
- Alarm signal.

Service-friendly

The integrated heat pump system has a very service-friendly design with easy access to all components inside the large inspection doors.

Drip tray with slope

The stainless steel drip tray with slope must be connected to a water trap with sufficient locking height (ø 40 mm outlet).

Cooling and heating capacity, example with Geniox 18 with heat pump

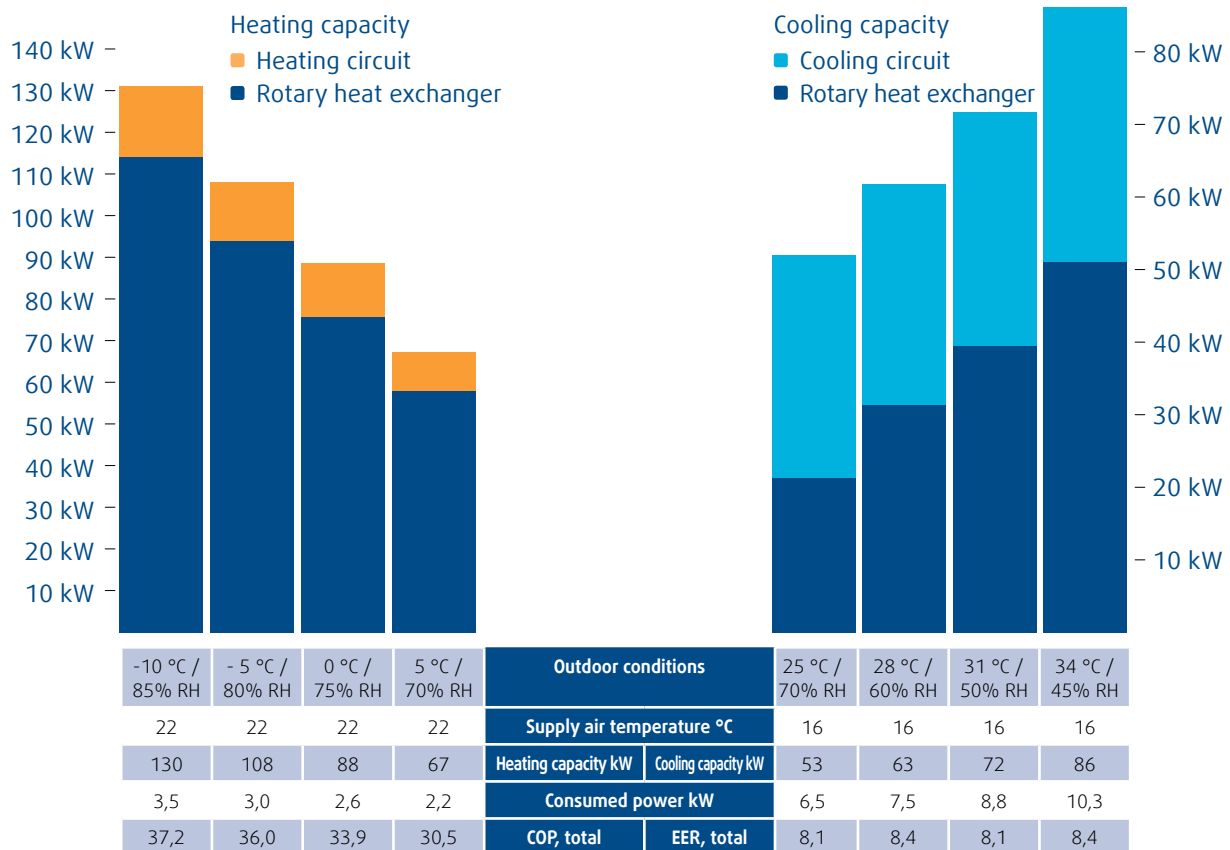

Performance example: Geniox 18 with 2,5 m³/s. Extract 22 °C/35% RH. Defrosting is not taken into account.

Performance example: Geniox 18 with 2,5 m³/s. Extract 23 °C/63% RH.

Cooling capacity

Unit size	10	11	12	14	16	18	20	22	24
Recommended max. airflow m³/s	0,8	1,2	1,6	2,0	2,5	3,0	4,0	4,8	5,3
Total cooling capacity kW	27	41	55	65	79	102	137	165	181
Capacity from the cooling circuit kW	12	18	24	29	34	44	59	73	77
EER, total	7,2	7,1	6,7	6,9	7,1	7,6	8,0	7,5	8,2

Outdoor conditions: 34 °C/45% RH. Supply air: 16 °C. Extract air conditions: 23 °C/63% RH.



Air humidifier

Humidifier for adiabatic cooling and humidification.

Function

The function is based on the natural process that water evaporates when air passes a wet surface. By uptake of water vapor in the air, the temperature will decrease due to the fact that heat for the evaporation comes from the air. This is an adiabatic cooling, which means that the enthalpy content of the air is unchanged during the process. This ensures that humidification occurs without releasing drops, unless this is affected by entrainment. Entrainment may be avoided by passing the humidification elements with a suitable low speed or by mounting droplet eliminators, which can handle this. The humidifier is VDI 6022 certified.

Application

The humidifier can be placed in the supply air after a heating coil which can preheat the air before humidification. Max. air velocity is 5.0 m/s. There may also be a need for an after heating coil in order to achieve the desired supply air temperature. In areas

with high outdoor temperature and low humidity, placement of the humidifier in the supply air can be used as adiabatic cooling with great advantage. Indirect adiabatic cooling can be achieved by placing it in the extract air before a plate heat exchanger. It is recommended to use a corrosion-protected heat exchanger.

Construction

The humidifier is designed as a complete unit that fits the internal dimensions of Geniox. The unit comprises humidification elements, tray and frame made of stainless steel, circulation pump, balancing valves for irrigation, overflow, valve for adjusting bleed off, float valve for controlling the water supply to the tray and valve for emptying the tray. Droplet eliminator is included if necessary and sensor for protection of pump at low water level. The drain is led out of the section, and can be selected either on the inspection side or the backside. The drain must be connected to a water trap with sufficient locking

height. The humidifier can be step-controlled as illustrated on the next page.

Humidification elements

HU-CELL humidification elements are stainless steel frames which contain corrugated fiberglass plates arranged in cross-channel configuration. The corrugated cross-channel configuration ensures that the air is in contact with a large surface area for evaporation, and at the same time provides a low pressure drop.

The glass fiber material is impregnated with a stabilizing and absorbent additive which makes it possible to absorb water without loss of stability. The element is of inorganic material, and is therefore not a feed source for bacteria and mould. The material contains silver ions, which act as a growth inhibitor. This increases the resistance to the growth of microorganisms and helps to release deposits from the water on the material, so that this remains clean. Silver ions are encapsulated in a chemical mixture, which ensures that their particles do not dissolve to either water or air.

The elements are supplied in the following thicknesses 75 mm, 100 mm, 125 mm, and 150 mm. This makes it possible to optimize the pressure drop depending on the desired humidification/cooling requirement.

Control system is not supplied.

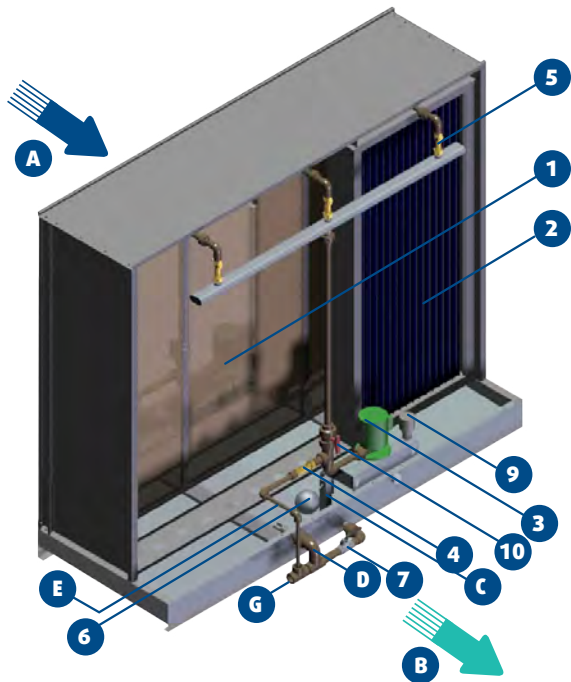

- A. Process air
- B. Humidified air
- C. Water supply
- D. Overflow
- E. Constant bleed off
- F. Drainage
- G. Water outlet to drain
- 1. Humidification element
- 2. Droplet eliminator (optional)
- 3. Water recirculations pump
- 4. Bleed off regulation valve
- 5. Irrigation regulation valves
- 6. Float valve
- 7. Draining valve
- 8. Filling solenoid valve (optional)
- 9. Max/min water level detector
- 10. Cut-off valve (depending on model)

Unit size	Number of stage valves/solenoid coil 24 V as standard and 230 V as an option
10	2
11	2
12	2
14	2
16	3
18	3
20	3
22	4
24	4
27	5
29	5
31	5

There are always 1 valve/solenoid coil supply water and 1 motor drain valves/solenoid coil 24 V as standard and 230 V as an option for both.

Operating principles

HEF2E (Recirculated water, standard on/off)

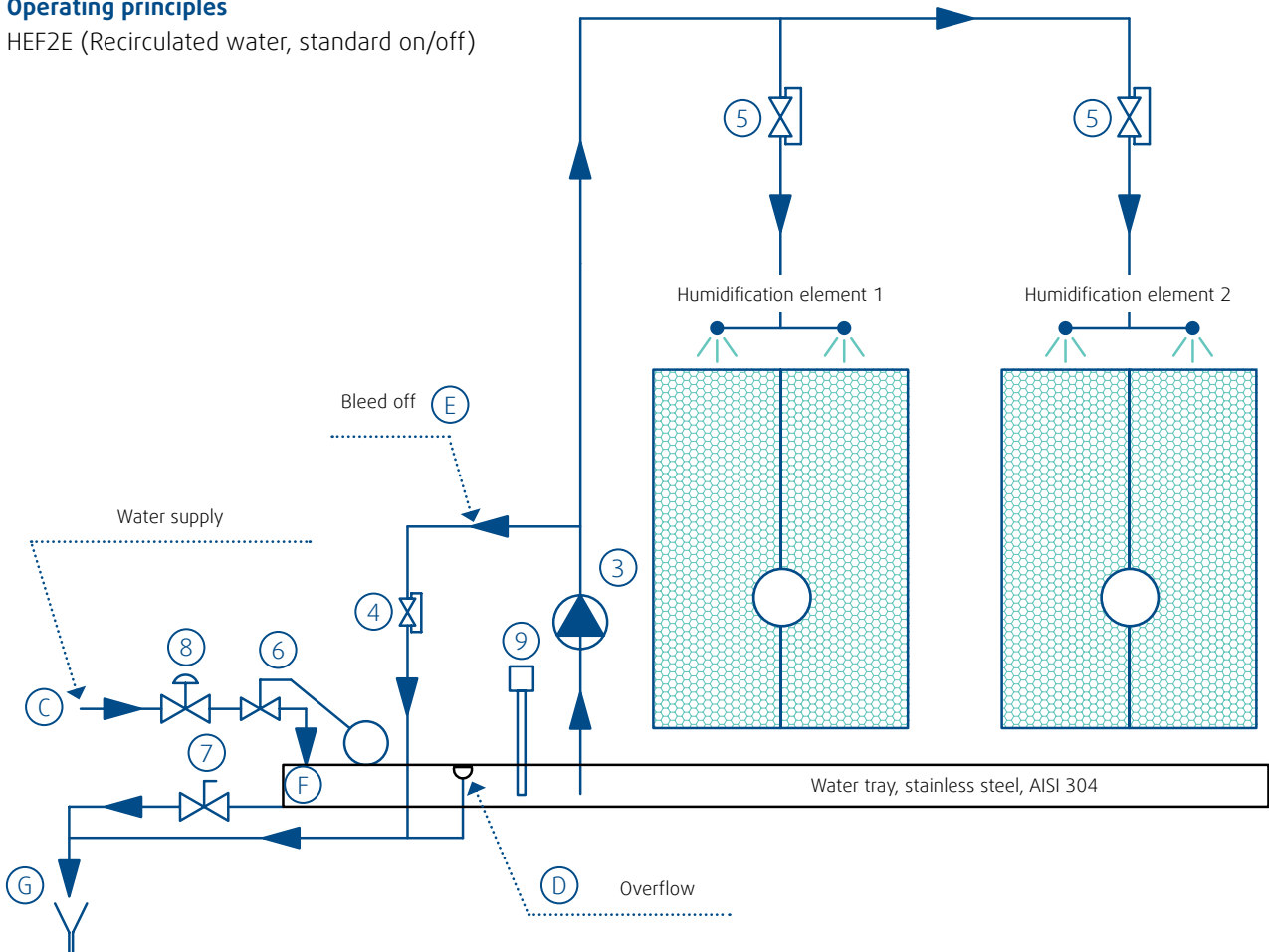



Panel filter

Prefilter

Filter classification

Coarse 65% (G4) according to EN ISO 16890.

Filter material

Synthetic polyester fibres.

Filter surface area

Large surface area due to the pleated filter form.

Filter frame

Framework encasing the filter with U-profiles of aluzinc.

Accessories

- U-tube manometer
- Magnehelic manometer
- Pressure outlet tab
- Spare filter
- Filter guard (on/off).

Unit size	Number and size
10	1x[792x392x48]
11	2x[490x392x48]
12	1x[490x490x48] + 1x[592x490x48]
14	2x[490x592x48] + 1x[287x592x48]
16	3x[490x592x48]
18	2x[490x392x48] + 4x[592x392x48]
20	3x[592x592x48] + 3x[592x287x48]
22	6x[592x490x48] + 2x[287x490x48]
24	3x[592x592x48] + 4x[490x592x48] + 1x[490x490x48]
27	2x[592x592x48] + 8x[490x592x48]
29	6x[592x592x48] + 4x[490x592x48]
31	5x[592x592x48] + 5x[592x490x48] + 5x[592x287x48]

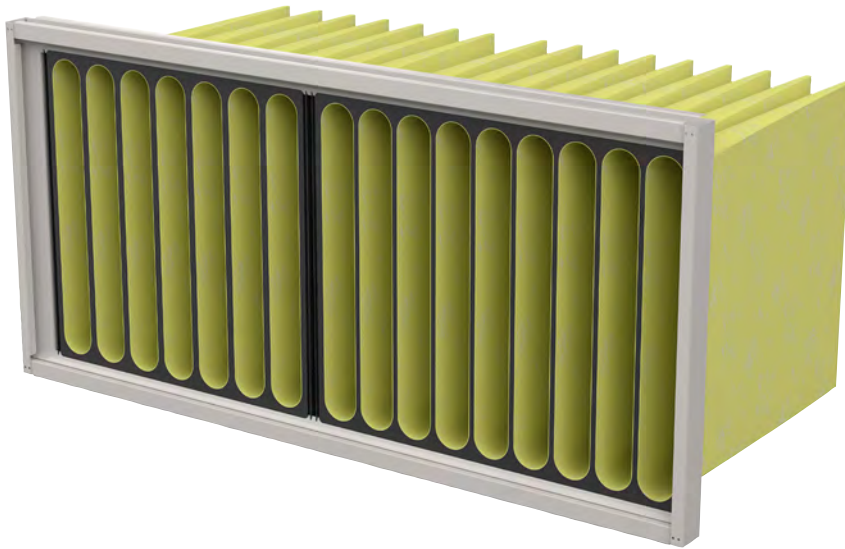

Bag filter

Prefilter, medium or fine filter.

Filter classification

Coarse 65% (G4), ePM10 60% (M5), ePM2.5 50% (M6), ePM1 60% (F7), ePM1 75% (F8), ePM1 85% (F9) or CITY-FLO ePM1 60% (F7 City-Flo) according to EN ISO 16890.

- ePM10 60% (M5), ePM2.5 50% (M6), ePM1 60% (F7), ePM1 75% (F8), ePM1 85% (F9): Glass fibre material.
- CITY-FLO ePM1 60% (F7 City-Flo): Glass fibre and coal with a wide spectrum.

Filter material

- Coarse 65% (G4): Synthetic material.

ePM1 60% (F7), ePM1 75% (F8), ePM1 85% (F9) are available in two lengths; 520 and 640 mm.

Filter frame

The filter cells are supplied with 25 mm standard plastic frame. Therefore, used filters can be disposed of in their entirety by combustion.

Sealing

Rubber sealing strips are fixed to the filter cells. Air tightness according to EN 1886:2008.

Fitting the filter cells

The cells are sealed with the enclosed sealing strips from Camfil. They are mounted on the filter profile (filter profile by ABS and TPE) with ease in a sliding movement.

Positioning of an ePM1 85% (F9) filter

The class ePM1 85% (F9) filter should always be positioned in the positive pressure side of the supply air unit (EN 1886:2008).

Accessories

- U-tube manometer
- Inclined tube manometer
- Magnehelic manometer
- Pressure outlet tab
- Stainless steel bottom plate
- Spare filter set
- Inspection window
- LED-light with external switch.

Unit size	Number and size of frames	Number of pockets in each filter cell					
		Coarse 65% L = 370 mm	ePM 10 60% L = 520 mm	ePM 2.5 50% L = 520 mm	ePM1 60%, 75% and 85% L = 520 mm	ePM1 60%, 75% and 85% L = 640 mm	CITY-FLO ePM1 60% L = 520 mm
10	1x[792x392]	12	12	12	12	12	12
11	2x[490x392]	8	8	8	8	8	8
12	1x[490x490] + 1x[592x490]	8+6	8+8	8+8	8+8	8+8	8+8
14	2x[490x592] + 1x[287x592]	5+8	5+5	8+5	8+5	8+5	8+5
16	3x[490x592]	5	5	8	8	8	8
18	2x[490x392] + 4x[592x392]	8+10	8+10	8+10	8+10	8+10	8+10
20	3x[592x592] + 3x[592x287]	6+6	6+6	10+10	10+10	10+10	10+10
22	6x[592x490] + 2x[287x490]	6+5	6+5	10+5	10+5	10+5	10+5
24	3x[592x592] + 1x[490x592] + 3x[592x490] + 1x[490x490]	6+5+6+8	6+5+6+8	10+8+10+8	10+8+10+8	10+8+10+8	10+8+10+8
27	2x[592x592] + 8x[490x592]	6+5	6+5	10+8	10+8	10+8	10+8
29	6x[592x592] + 4x[490x592]	6+5	6+5	10+8	10+8	10+8	10+8
31	5x[592x592] + 5x[592x490] + 5x[592x287]	6+6+6	6+6+6	10+10+10	10+10+10	10+10+10	10+10+10



Metal filter

Prefilter

Filter class

G2 according to EN ISO 16890.

Filter frame

Stainless steel.

Cleaning

Washable.

Filter material

The filter cells are made from electro-galvanised aluminium thread that is weaved together.

Application

The metal filter is used as a prefilter in the extract air, where there may be grease particles in the air. However, there should always be a grease filter in the cooker hood. The metal filter is also efficient as a prefilter where there is dust, sand, flour, paint or oil in the outdoor air.

Accessories

- U-tube manometer
- Magnehelic manometer
- Stainless steel base
- Filter guard (on/off)
- Spare filter
- LED light with external switch.

Filter area

Very large surface, without additional air resistance.

Unit size	Number and size
10	1x[792x392x40]
11	2x[490x392x40]
12	1x[490x490x40] + 1x[592x490x40]
14	2x[490x592x40] + 1x[287x592x40]
16	3x[490x592x40]
18	2x[490x392x40] + 4x[592x392x40]
20	3x[592x592x40] + 3x[592x287x40]
22	6x[592x490x40] + 2x[287x490x40]
24	3x[592x592x40] + 4x[490x592x40] + 1x[490x490x40]
27	2x[592x592x40] + 8x[490x592x40]
29	6x[592x592x40] + 4x[490x592x40]
31	5x[592x592x40] + 5x[592x490x40] + 5x[592x287x40]



Carbon filter

Supply air, recirculation, or exhaust filter.

Filtermaterial

- Carbon type CEX003 in a cylindrical cartridge.
- Length 450 mm.
Max. air flow 1,120 m³/h, 135 Pa.
- The air flow and pressure are applicable for 16 cylinders on a 610 x 610 mm bottom plate.

Filter cartridge

Cartridge frame in solid cast plastic.

Application

A molecular filter for high efficiency and long term control of molecular pollution in sensitive buildings and the processing industry. The carbon filter is effective against airborne molecules, such as odours, Volatile Organic Components (VOCs), toxic gasses, and corroding elements. The filter can also be used as a recirculation or exhaust filter.

Limit values

Temperature: -20 - +60 °C
Humidity: RH max. 70%
Recommended contact time:
Min. 0.2 sec. (calculated in SystemairCAD).

Placement

The carbon filter is typically placed as a prefilter in the supply air. To ensure that the filter does not get dirty, you should always place an ePM1 60% (F7) filter in front of the carbon filter.

Accessories

- Spare filter
- Inspection window
- LED light with external switch.

Unit size	Type	Number of cartridges
10	F 10 Carbon (CamCarb Green CG 2600-CEX003)	10
11	F 11 Carbon (CamCarb Green CG 2600-CEX003)	18
12	F 12 Carbon (CamCarb Green CG 2600-CEX003)	21
14	F 14 Carbon (CamCarb Green CG 2600-CEX003)	32
16	F 16 Carbon (CamCarb Green CG 2600-CEX003)	36
18	F 18 Carbon (CamCarb Green CG 2600-CEX003)	55
20	F 20 Carbon (CamCarb Green CG 2600-CEX003)	72
22	F 22 Carbon (CamCarb Green CG 2600-CEX003)	84
24	F 24 Carbon (CamCarb Green CG 2600-CEX003)	98
27	F 27 Carbon (CamCarb Green CG 2600-CEX003)	128
29	F 29 Carbon (CamCarb Green CG 2600-CEX003)	136
31	F 31 Carbon (CamCarb Green CG 2600-CEX003)	162



Damper

The dampers can be used as shut-off dampers for intake, extract, exhaust, and outdoor air. The dampers can also be used for mixing and recirculation.

Air tightness classification

- Class 4 (leakage through a closed damper).
 - Class C (casing leakage).
- According to EN 1751:2014.

Damper blades

Aerodynamically formed aluminium profiles. Can be supplied as an insulated option.

Bearings

Synthetic bearings with large bearing surfaces.

Sealing

Rubber sealing strips between the damper blades. Special sealing between frame and damper blades.

Shafts



12 mm steel

Blade pivoting system

Composite gears combined with steel rods.

Blade position indicator

Arrow for indication of the blade position.

Damper motor

The dampers are activated by a motor for each damper.

Motor bracket

Bracket for fixing of a damper motor for each damper.

Damper types

There are four types of dampers for each unit size. The dampers can be placed in end, top, or back of the unit and between airflows, allowing high flexibility.

Damper type	Internal in unit	External on unit
1	Full face, top, and end of unit. Geniox 10-24 one damper motor, Geniox 27-31 two damper motors.	Full face, top of unit. Geniox 10-24 one damper motor.
2	Half face, top of unit, and mixing damper. Geniox 10-24 one damper motor, Geniox 27-31 two damper motors.	Half face, top of unit. Geniox 10-24 one damper motor.
3		Full face, back of unit. Geniox 10-20 one damper motor.
4		Half face, back of unit. Geniox 10-31 one damper motor.



Dampers external on unit – Duct connection sizes, 20 mm flange connection

Damper type		10	11	12	14	16	18	20	22	24	27	29	31
1	W	750	850	950	1150	1350	1550	1750	1950	2150	-	-	-
	H	400	400	500	600	700	800	900	1000	1100	-	-	-
2	W	750	850	950	1150	1350	1550	1750	1950	2150	-	-	-
	H	200	200	300	300	400	400	500	500	600	-	-	-
3	W	800	900	1000	1200	1400	1600	1800	-	-	-	-	-
	H	400	400	500	600	700	800	900	-	-	-	-	-
4	W	400	400	500	600	700	800	900	1000	1100	1200	1300	1400
	H	400	400	500	600	700	800	900	1000	1100	1200	1300	1400

Dampers internal in unit – Duct connection sizes

Damper type		10	11	12	14	16	18	20	22	24	27	29	31
1	W	1000	1100	1200	1400	1600	1800	2000	2200	2400	2700	2900	3100
	H	400	450	500	600	700	800	900	1000	1100	1200	1300	1400
2	W	1000	1100	1200	1400	1600	1800	2000	2200	2400	2700	2900	3100
	H	300	300	400	400	500	500	600	600	700	700	800	800

Required torque (Nm) for each damper motor with varying pressure drops

Pressure drop	10	11	12	14	16	18	20	22	24	27	29	31
0 Pa	4	5	6	7	8	9	11	12	14	15	17	18
500 Pa	7	8	10	11	13	14	16	17	19	21	23	24
1000 Pa	9	11	13	15	17	19	20	22	24	26	28	29



Sound attenuator

The sound attenuator is used to reduce the sound power level from the air handling unit to the duct system.

Construction

The sound attenuator is an absorption attenuator with baffles made of rockwool. The baffles are surface treated in order to prevent the absorption material fibres from being carried away. Is also available for installation on duct.

Variants

1. Baffles with standard lining. Each baffle is enclosed in an Aluzinc frame.
2. Baffles with standard lining for dry cleaning. The air handling unit casing has large inspection doors for easy cleaning.
3. Baffles with a synthetic lining, ideal for wet cleaning. Each baffle is enclosed in a stainless steel frame. The air handling unit casing has large inspection doors for easy cleaning.

Attenuation dB	Mid-frequency Hz							
	63	125	250	500	1000	2000	4000	8000
Geniox, length 600	3	7	11	18	29	32	29	20
Geniox, length 900	5	11	17	25	36	39	36	28
Geniox, length 1200	7	15	23	32	43	46	43	36
Geniox, length 1500	9	19	29	39	50	53	50	44
Geniox, length 1800	11	23	35	46	57	60	57	52



Inspection section

The inspection section is used where the option of service, inspection, or measuring is required, before or after an air handling function.

Construction

The inspection section consists of an empty unit casing with an inspection door.

Accessories

- Inspection window fitted into the inspection door.
- LED lamp with external switch.
- Pressure outlet tab.



Empty section

Used in units where space is required to fit a component, e.g. a temperature sensor, or to have the option of applying an extra air handling function at a later date.

Construction

The empty section consists of an empty unit casing, where the side panels are assembled with screws.

Accessories

- Inspection window fitted into the inspection door
- LED lamp with external switch.



Outdoor air section

The outdoor air section is used for air intake and outlet in roof units.

Function

The outdoor air section has air intake through the end of the unit, and outlet of exhaust air through the back wall of the unit.

Construction

The outdoor air section consists of an air handling unit casing with inspection door. The openings for air intake and outlet have louvers for effective protection against rain and snow. The outdoor air section can be delivered pre-painted.

Type 1

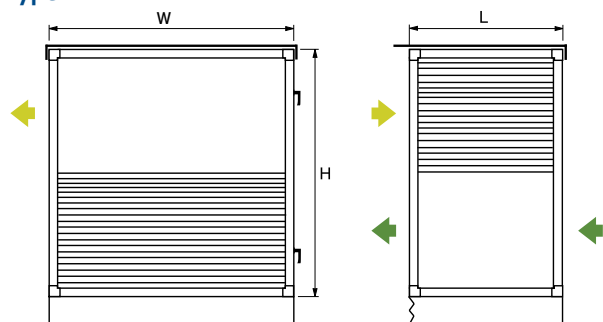

Type 2

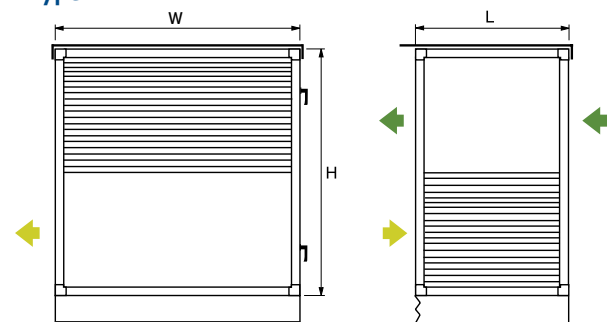

← Exhaust air Outdoor air →

Dimensions

Unit size	10	11	12	14	16	18	20	22	24	27	29	31
Width W	1082	1182	1282	1482	1682	1882	2082	2282	2482	2782	2982	3182
Height H	1082	1182	1282	1482	1682	1882	2082	2282	2482	2764	2964	3164
Length L	600	600	800	900	1000	1100	1200	1300	1400	1500	1700	1900



Supporting legs

Units in sizes Geniox 10-18 for indoor installation can be supplied with supporting legs.

Construction

Supporting legs are made of Magnelis ZM310. Pre-painting in RAL 7024 of the supporting legs is an option. They are 118 mm high, and have feet which are adjustable from 30-55 mm.

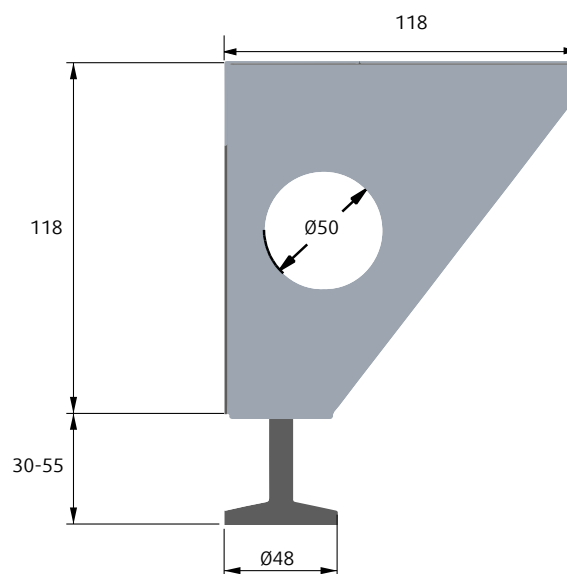



Standard base frame and base frame with high legs

Standard base frame

Units for indoor installation can be supplied with base frame in height 118 mm with \varnothing 50 mm holes or 218 mm with \varnothing 80 mm holes. The base frame has feet which are adjustable from 30-55 mm.

Minimum length of base frame is 400 mm. Maximum length of the base frame is 6000 mm for units Geniox 10-24 and 4600 mm for units Geniox 27-31. Longer units are supplied divided on two or more base frames. The base frame is self-supporting, but as a minimum it must be supported in each corner and on the longitudinal profiles for each 1500 mm.

Construction

The base frame consists of strong, galvanized steel profiles, 118 mm or 218 mm height assembled with bolts. The unit can be delivered installed on the base frame from factory, or the base frame can be delivered separately. Pre-painting in RAL 7024 of the base frame is an option.

Base frame with high legs

It is possible to choose additional high legs for base frames. These legs will always be 250 mm high and they will be delivered with feet which can be adjusted 120 mm. This facilitates easy access for cleaning under the unit. The length and width of the unit determines the number of legs needed. Pre-painting is an option for the base frame as well as for the high legs.

Geniox air handling units for outdoor installation

Geniox air handling units for outdoor installation are always supplied with 218 mm base frame with \varnothing 80 mm holes. As extra protection against corrosion, base frames for outdoor installation can be supplied pre-painted. The unit will always be installed on the base frame when delivered.

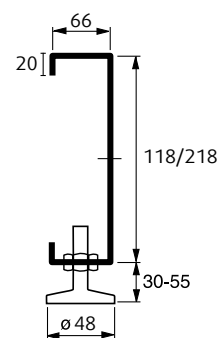

Standard base frame



Base frame with forklift holes

Geniox air handling units for indoor installation

In order to save time on the building site it is an option to choose a unit delivered on a base frame with forklift holes. This is an option for Geniox sizes 10-31 (not applicable for units with heat pumps).

Construction

The height of the base frame is always 118 mm. Minimum length of section is 700 mm in order to ensure enough space for the forklift holes. The unit will always be installed on the base frame when delivered, and the base frame will be adjusted to the lengths of the unit sections, max. 2882 mm. The base frame is made of 3 mm galvanized steel sheets. The base frame can be delivered pre-painted, RAL 7024.



Assembly brackets

The assembly bracket is designed to ensure an airtight connection between the casing sections.

Assembly brackets

For air handling units divided in sections, the assembly brackets are mounted externally. Screws and nuts are delivered separately. For air handling units mounted on a base

frame and assembled in the factory, the assembly brackets are mounted inside the unit. The brackets ensure that the sections are aligned at the end of the assembly.

Construction

The brackets are made of zinc and pre-painted in dark grey.



Duct connection part

The connection part is used when connecting duct work to the Geniox air handling unit, either as rigid connection or as rigid and flexible connection.

Variants

End of unit.
 Top half face.
 Top full face.
 Back of unit.

Dimensions

Unit size		10	11	12	14	16	18	20	22	24	27	29	31
End of unit	D	1000	1100	1200	1400	1600	1800	2000	2200	2400	2700	2900	3100
	E	400	450	500	600	700	800	900	1000	1100	1200	1300	1400
Top half face	D	1000	1100	1200	1400	1600	1800	2000	2200	2400	2700	2900	3100
	E	300	300	400	400	500	500	600	600	700	700	800	800
Top full face	D	1000	1100	1200	1400	1600	1800	2000	2200	2400	2700	2900	3100
	E	500	500	600	700	800	900	1000	1100	1200	1300	1400	1500
Back of unit	D	600	600	700	900	900	1100	1100	1300	1300	1500	1700	1900
	E	500	550	600	700	800	900	1000	1100	1200	1300	1400	1500

Duct connection part

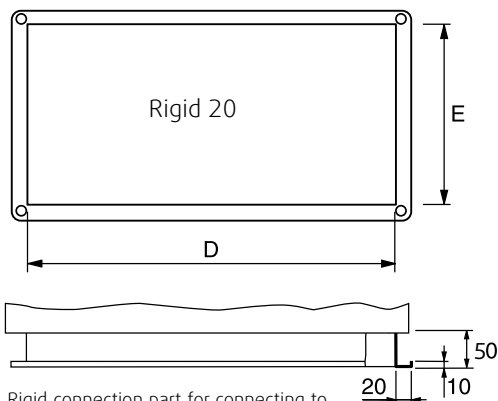

Rigid connection part for connecting to 20 mm LS profile for C-rail, and for 20 mm EP/LSM profile with holes in the corners.

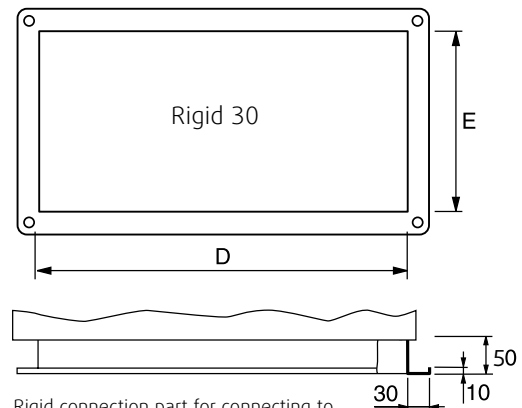

Rigid connection part for connecting to 30 mm EP/LSM profile with holes in the corners.

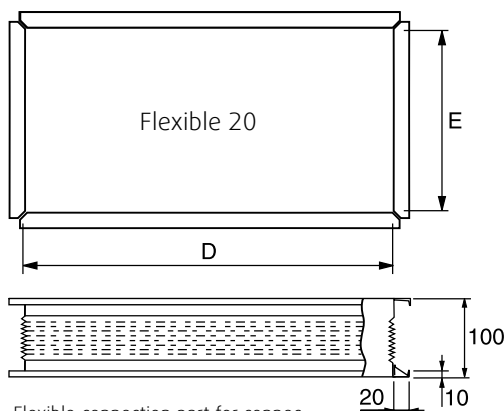

Flexible connection part for connecting to 20 mm LS profile for C-rail. For mounting in continuation of rigid connection part.

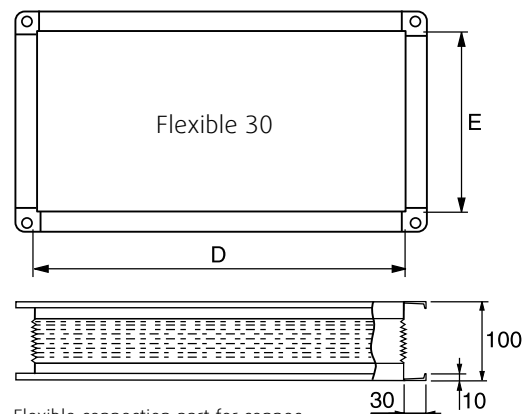

Flexible connection part for connecting to 30 mm EP/LSM profile with holes in the corners. For mounting in continuation of rigid connection part.

