



NIBE GROUP MEMBER

APPLIED SYSTEMS

Product Catalogue 2021



| Chillers | Heat pumps | Fan coils | Terminal units |
| Solutions to control the integrated system |



A global organisation
with companies
and a presence
worldwide

NIBE Group is a global organisation that contributes to a smaller carbon footprint and better utilisation of energy. In its three business areas – Climate Solutions, Element and Stoves – we develop, manufacture and market a wide range of eco-friendly, energy-efficient solutions for indoor climate comfort in all types of property, plus components and solutions for intelligent heating and control in industry and infrastructure.

From its beginning in Markaryd, in the province Småland ***more than 60 years ago, NIBE has grown into an international company with more than 15,000 employees and a presence worldwide.*** From the very start, the company was driven by a strong culture of entrepreneurship and a passion for responsible business operation. Its success factors are long-term investments in sustainable product development and strategic acquisitions. Combined, these factors have brought about strong, targeted growth, which generated sales of just over SEK 20 billion (EUR 2 billion).





Be the change
you want to see
in the world



Our focus on world-class solutions in sustainable energy contributes to the global goal to reduce emissions of greenhouse gases into the atmosphere.

Our entire value chain, from vision to end customers, must be based on the principles of sustainability in our business principles.

We are responsible not only for the financial results of our operations but also for their social and environmental impact.

NIBE's responsibility forms the Group's framework for sustainability efforts in four different areas:



IN
BUSINESS



FOR THE
ENVIRONMENT



RESPONSIBILITY
FOR EMPLOYEES



LOCAL SOCIAL
RESPONSIBILITY

Change
your perspective!
Solutions
that look
to the future.



Inverter scroll compressors

4 kW 131 kW



ELECTA ECO
4÷15,5 kW
Web code: EE001
PAGE 22



Electa-ECOS-B
3,2÷9,5 kW
Web code: EESB1
PAGE 24



Electa-ECOS-T
3,1÷9,5 kW
Web code: EEST1
PAGE 26



MidiPACK-I
18,8÷30,4 kW
Web code: CYI02
PAGE 34



new

MidiPACK-I ECO
29,5÷55,2 kW
Web code: MDI12
PAGE 40



MidiPACK-I
37,4÷71 kW
Web code: CYI12
PAGE 42

Hermetic scroll compressors

6 kW 131 kW



Mini-Y NF
5,6÷11,3 kW
Web code: MYN01
PAGE 32



Compact-Y MD
32,3÷63,7 kW
Web code: CY011
PAGE 44



POKER
28,8÷115,2 kW
Web code: PK001
PAGE 46



Compact-Y NF
15,5÷26,6 kW
Web code: CYP01
PAGE 36

Compact-Y SM
15,7÷29,5 kW
Web code: CY001
PAGE 38



Inverter screw compressors

510 kW 1307 kW



FullPOWER VFD (1+i)
518÷1307,4 kW
Web code: FPV21
PAGE 88



FullPOWER VFD
510÷1001,5 kW
Web code: FPV11
PAGE 86

Semi-hermetic screw compressors

317 kW 1307 kW



FullPOWER HE-A
317÷1325 kW
Web code: FPE11
PAGE 90

FullPOWER SE
319÷1271 kW
Web code: FP011
PAGE 94

Oil-free centrifugal compressors

267 kW 1307 kW



Air-water heat pump for domestic hot water.

**Electa-SAN**

200 -300 l
Web code: ESW01
PAGE 28

**EasyPACK-I**

67,1÷130,4 kW
Web code: EAI01
PAGE 50

917 kW

new

**EasyPACK ECO**

69,4÷153,7 kW
Web code: EAS02
PAGE 52

**EasyPACK**

63,7÷144,4 kW
Web code: EAS01
PAGE 52

**Y-Pack FREECOOLING**

170÷361 kW
Web code: YKF11
PAGE 70

**WinPACK HE-A**

91,6÷345 kW
Web code: WKE11
PAGE

**WinPACK SE**

97,6÷328,6 kW
Web code: WK011
PAGE 60

**WinPACK-R HE-A**

221,4÷372 kW
Web code: WKE21
PAGE 66

**WinPACK-R SE**

214,2÷345,7 kW
Web code: WK021
PAGE 68

**WinPOWER HE-A**

337,3÷916,8 kW
Web code: WPE11
PAGE 76

**WinPOWER SE**

335÷861,8 kW
Web code: WP011
PAGE 83



new

**WinPOWER ECO**

359,7÷664,5 kW
Web code: WPE05
PAGE 76

**Z-Power SE**

1404,4÷1.609,7 kW
Web code: ZP001
PAGE 98



1600 kW

**Z-Power FREECOOLING**

469÷1.216 kW
Web code: ZPF01
PAGE 100

949 kW

**TurboPOWER**

267,0÷1101 kW
Web code: TP011
PAGE 104

**TurboPOWER ECO**

323,2÷948,6 kW
Web code: TP014
PAGE 106



ONLY COOLING



HEAT PUMP



POLYVALENT SYSTEMS

CHILLERS - HEAT PUMPS

Air-cooled
Centrifugal fans

PAGE 109

Inverter scroll compressors

16 kW

160 kW

Hermetic scroll compressors



Compact-ID
16,4÷27,5 kW
Web code: CIDO1
PAGE 110



Y-Pack C-PF
32,3÷160,2 kW
Web code: YKC11
PAGE 112

Water cooled - Condenserless units

PAGE 117

Water cooled
Hermetic scroll compressors

5 kW



Comby-Flow
5,3÷11,9 kW
Web code: CF001
PAGE 118



Y-Flow
15,5÷41,7 kW
Web code: YF011
PAGE 120



Y-Flow
41,2÷448,8 kW
Web code 245÷2185: YF021 - Web code 4180÷4410: YF031
PAGE <?>

Condenserless units
Hermetic scroll compressors

13 kW



Y-Flow E
13,7÷36,9 kW
Web code: YFC11
PAGE 134



Y-Flow E
39,8÷320,9 kW
Web code 245÷2185: YFC21 - Web code 4180÷4360: YFC31
PAGE 136

EXP - Polyvalent systems

Air cooled - Axial fans

PAGE 141

Hermetic scroll compressors

18 kW



Compact-Y EXP SM
17,7÷29,1 kW
Web code: CYX11
PAGE 142



Compact-Y EXP MD
33,8÷61,6 kW
Web code: CYX21
PAGE 144



WinPACK ECO EXP
135,7÷333,6 kW
Web code: WKX15
PAGE 148

Inverter scroll compressors



EasyPACK-I EXP
64,4÷133,2 kW
Web code : EAX01
PAGE 146

Water cooled

Hermetic scroll compressors

5 kW

438 kW



Comby-Flow EXP
5,5÷12,2 kW
Web code: CFX01
PAGE 156



Y-Flow EXP
44,2÷437,8 kW
Web code 245÷2185: YFX21 - Web code 4180÷4410: YFX31
PAGE 158

Condensing units

PAGE 163



CUY01
16,4÷31,5 kW
Web code: CUY01
PAGE 164



CUY11
34,5÷162,6 kW
Web code: CUY11
PAGE 165

System accessories

Remote condensers

PAGE 167



CCAMY
23÷218 kW
Web code Mod. 115÷240: CRYA1
Mod. 245÷2185: CRYA2
PAGE 168

Inverter screw compressors



FullIFLOW VFD (1+i)

389,5÷1701,1 kW

Web code: FFE03

PAGE 126



FullIFLOW ECO VFD (1+i)

285,6÷1217,2 kW

Web code: FFE04

PAGE 128

Semi-hermetic screw compressors



new



FullIFLOW DX

201,7÷1.455,2 kW

Web code: FFD03

PAGE 130

1628 kW

**Condenserless units
Semi-hermetic screw compressors**



Z-Flow E

171,9÷1.424,8 kW

Web code: ZFC01

PAGE 138



1425 kW

648 kW



Y-Pack EXP

80,7÷332,9 kW

Web code: YKX11

PAGE 150



new



WinPOWER ECO EXP

352,7÷645,5 kW

Web code: WPX05

PAGE 76



WinPOWER EXP

361,2÷648,1 kW

Web code: WPX01

PAGE 154



Pumping units
AS 300÷2500 l
Web code: GPA01
PAGE 172



Boilers for domestic hot wa
KACS
200-300-500 l
Web code: ACCBL
PAGE 174



Thermal flywheel
KSI
25-50-100-200 l
Web code: ACCSB
PAGE.7

		WALL MOUNTING INSTALLATION	FLOOR, CEILING, RECESSED WALL OR FALSE CEILING INSTALLATION		
FAN COILS	PAGE 179 - CONTROLS PAGE 217	Inverter Brushless motor	<p>IDROWALL-I 2,0÷3,5 kW Web code: IDRO1 PAGE 214</p> 	<p>BRIO-I SLIM 1,0÷4,0 kW Web code: BRIS1 PAGE 182</p> 	<p>YARDY-I EV3 1,9÷8,6 kW Web code: YARI3 PAGE 190</p>  <p>air'suite</p>
		Standard motor			<p>YARDY EV3 1,1÷8,5 kW Web code: YARV3 PAGE 192</p>  <p>air'suite</p>

TERMINAL UNITS	Air handling terminal units 850÷16500 m³/h	PAGE 230	 <p>Terminal unit UTNA Platinum 6,4÷70 kW Web code: UTAP1 PAGE 18</p>		
	Compact heat recoveries 100÷5300 m³/h	PAGE 234	<p>Heat recovery unit Electa-REK Thermodynamic heat recovery 200-300-150/450 m³/h Web code: ERK01 PAGE 234</p> 	<p>Heat recovery unit UTNR-A Platinum Counterflow heat recovery 400÷4.700 m³/h Web code: UTNR3 PAGE 26</p> 	<p>Heat recovery unit UTNR-HE Platinum Rotative heat recovery 310÷4.250 m³/h Web code: UTHE3 PAGE 30</p> 
		<p>Heat recovery unit UTNR-HP Thermodynamic heat recovery 350÷4.500 m³/h Web code: UTHP1 PAGE 38</p> 	<p>Heat recovery unit VMC-E Counterflow heat recovery 250÷1.000 m³/h Web code: VMC01 PAGE 40</p> 		

DUCTED INSTALLATION

FALSE CEILING CASSETTE



YARDY-ID2
2,4÷6,4 kW
Web code: YAI2
PAGE 202



DIVA-I
2,8÷10,8 kW
Web code: DIV1
PAGE 208



DIVA-XLI DIVA-XLI SWING
12,6÷15,1 kW
Web code: DIX1 - Web code: DIXS1 -
Web code controls: ACREG
PAGE 210

YARDY-DUCT2
2,0÷5,8 kW
Web code: YADC2
PAGE 204



YARDY-HP
7,2÷20,5 kW
Web code: YAHP1
PAGE 206



DIVA
2,0÷11,1 kW
Web code: DIVA1
PAGE 212



MANAGEMENT SYSTEMS, CONTROL AND MONITORING

INTEGRATED SYSTEM MANAGEMENT

PAGE 258

SYS-T0
System Touch Manager & Web APP



CONTROL AND MONITORING VIA ETHERNET

PAGE 272

RHOSS WEB SERVER



REMOTE MONITORING

PAGE 270

RHOSS MONITORING:
Mobile - Cloud - Real time



CHILLER MANAGEMENT SOFTWARE

SIR - RHOSS INTEGRATED SEQUENCER - PAGE 268

MTM - MULTI TECHNOLOGY MANAGER - PAGE 262

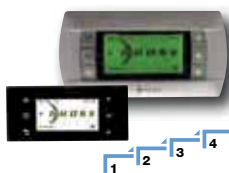

RHOSS: the conscious choice for an ecological future

EFFICIENCY, TECHNOLOGY and ECOLOGY: the three key words for a sustainable future.

Rhoss has always been careful to create comfort, and invests and researches new solutions to be applied to equipment dedicated to the HVAC world: efficiency and technology are firm points in the development of new products in order to make them more and more compatible with the environment which we live in.

The progressive elimination of fluorinated refrigerants (HFCs), established by the new EU regulation, provides for a gradual reduction of the quantities placed on the market, expressed as the equivalent in tons of CO₂. This should lead to a reduction of HFC consumption of 79% by 2030.

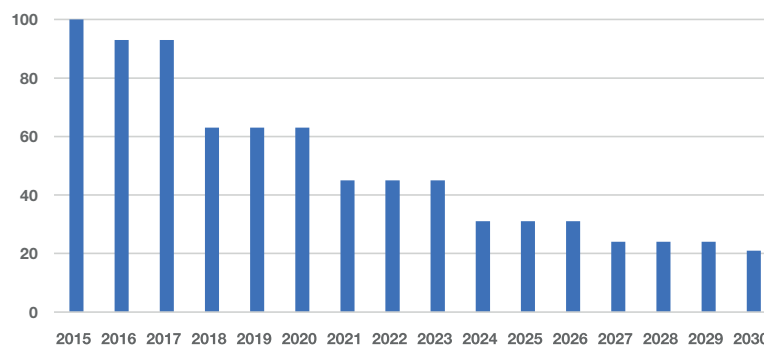

Volume di riferimento (100%) corrispondente alla media annuale della quantità totale di CO₂ equivalente immessa all'interno dell'UE nel periodo dal 2009 al 2012.

The application of this legislation will lead to the introduction and increasingly massive use of new low-GWP (Global Warming Potential) gases, consistent with the evolution of technology.

In fact, in the world market of refrigerants, depending on the technology used, there are many solutions that allow for a reduction in GWP, with respect to the gas traditionally used in the HVAC sector.



The following table indicates some examples of refrigerant gases and related GWP.

Refrigerant	GWP (UNI EN 378-1 2017)	
R407C	1774	
R134a	1450	
R410A	2088	
R513A	631	✓
R1233zd	4,5	✓
R1234ze	7	✓
R32/R452 B	675	✓
R454 B	466	✓

Rhoss has long started this process of harmonisation with the new “green” gases, testing and experimenting with new solutions, without precluding any possibility.

Furthermore, all the ranges in the catalogue for which Rhoss provides solutions with low GWP refrigerant are distinguished by a specific mark.

The gradual phase-down of high GWP refrigerants is also accompanied by the demand for increasingly efficient and low-consumption products as required by the European Ecodesign Directive. This provides the specifications for an environmentally friendly design of all energy-using products and through Regulations 813/2013 and 2016/2281 imposed minimum seasonal winter (SCOP) and summer (SEER) efficiency requirements for the introduction of chillers and heat pumps in the European market.

The product performance tables, therefore, indicate the SEER and SCOP indexes, in line with the requirements of the directive.

Our certifications, in 360 degrees



ISO 9001:2015 Certification

RHOSS Spa provides quality goods designed for environmental comfort, making them available and accessible thanks to the advanced technological and organisational level achieved, and, above all, to the committed, reliable and dedicated approach that RHOSS personnel take to their job every day. The organisation and operations of the business are based on a Quality Management System. The Quality System currently implemented with the new ISO 9001-2015 version is based on rules and practices that are established and agreed on with the entire organisation.



ISO 14001:2015 Certification

RHOSS Spa supplies quality goods designed for environmental comfort. With the same commitment, it pays attention to environmental issues, considering correct management and efficient control of its environmental aspects of prime importance, engaging in Environmental Protection and in full compliance with the standards in force and with specific requirements. For this reason, Management has decided to implement an environmental certification system, based on the requirements of the international standard UNI EN ISO 14001, applying it to all the activities carried out within the company and especially to its production activities.



EUROVENT certification for CHILLERS, HEAT PUMPS (CCP-HP) AND FAN-COILS (FCU)

Rhoss participates in the Eurovent certification programmes for chillers, heat pumps and fan coils. The performance of Rhoss products is therefore guaranteed by tests performed by an accredited third party certification company.



EUROVENT certification for AIR HANDLING UNITS (AHU)

Rhoss participates in the Eurovent certification programme for the Air handling units with the ADV and NEXTAIR range according to the EN 13053 standard; certification of mechanical characteristics according to EN1886; and the energy classification of the machines.



LEED certification - Leadership in Energy & Environmental Design

Rhoss participates in the certification protocol of LEED buildings. The international system is based on the entire building life cycle from design and construction to management and maintenance.

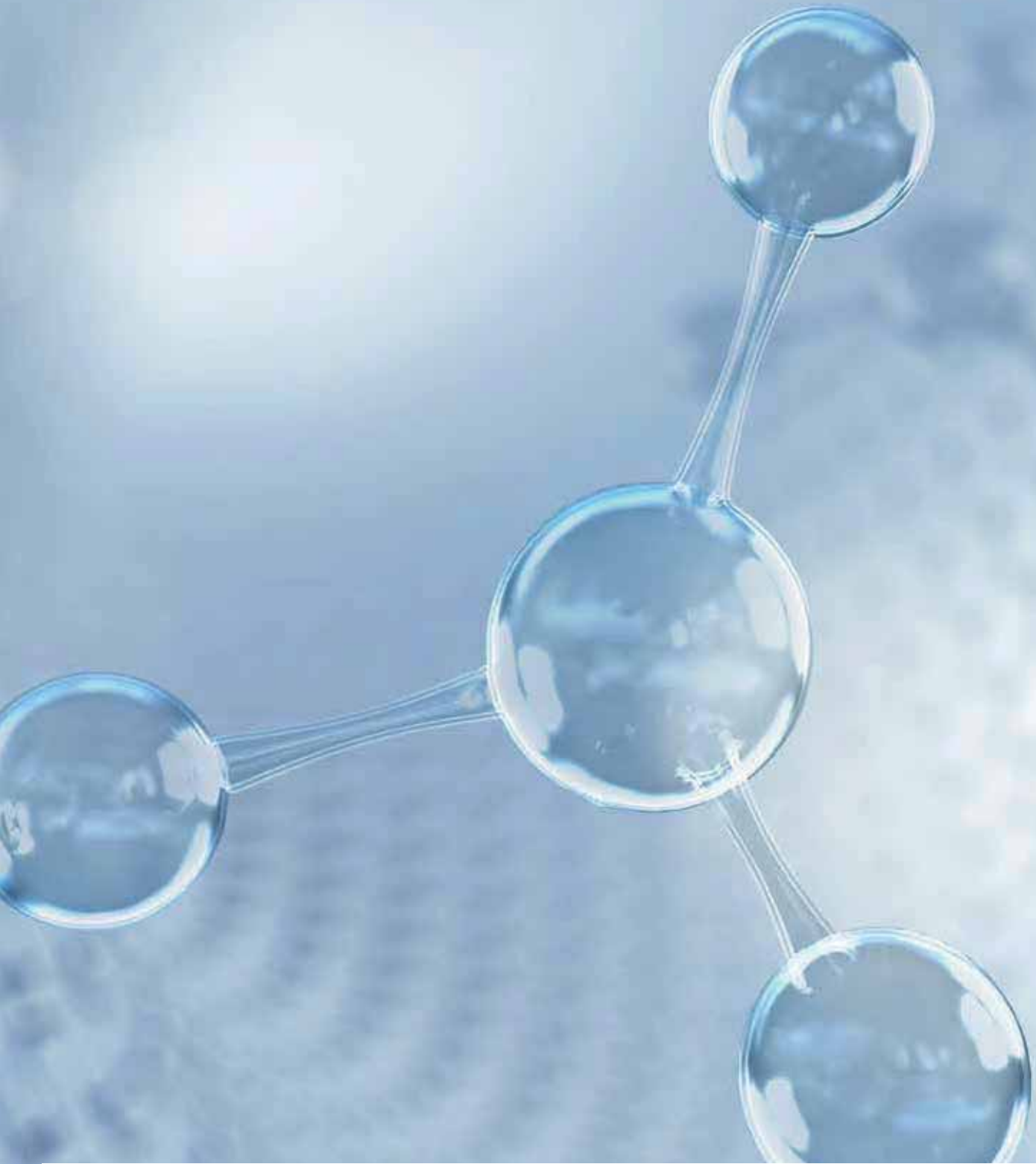

2

2-pipe systems
AUTOMATIC or SELECT modes

Summer **"AUTOMATIC"**
cooling and domestic hot water

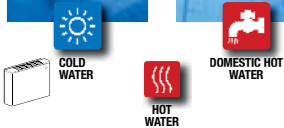

Winter **"SELECT"**
heating and domestic hot water

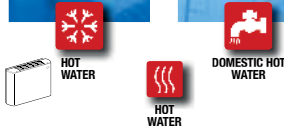

4

4 or 6-pipe systems **
AUTOMATIC mode throughout the year

6

Summer
cooling

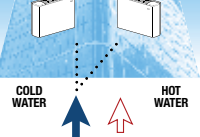

Mid-season
cooling and heating

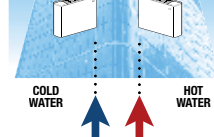

Winter
heating

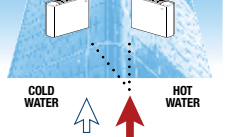

Innovation is in our DNA



The assurance of a quality product is obtained by means of thorough tests in the R&D Lab, one of the largest testing labs in Europe.

Every Rhoss unit is subjected to rigorous operating tests before being launched on the market, simulating the most extreme operating conditions.

EXP Systems is the multi-purpose ecological system designed by RHOSS to satisfy cold and hot water demands simultaneously or independently with a single unit. It is designed for use in 2, 4 and 6-pipe systems, at any time of year.

This flexibility allows it to be used in several types of construction, thereby allowing any subsequent change in the intended use.

An entire range with air and water cooled from 5 to 700 KW with TER* index up to 8.

* TER Total Efficiency Ratio in total heat recovery mode AUTOMATIC 2.
** 6-pipe systems achievable with the WinPOWER EXP, WinPOWER ECO EXP, EasyPACK-1 EXP ranges.

Polyvalent systems
the evolution of energy Savings

Download the complete document:

<http://www.rhoss.com/download>



VPF solution by RHOSS: the new plant engineering breakthrough

Cooling systems with VPF (Variable Primary Flow), ideal for medium to large cooling capacities, are an interesting alternative to more conventional constant flow systems. In fact, the solutions designed by Rhoss offer benefits like reduced pumping unit energy consumption with consequent cost savings, as well as reliability and simplified system control.

Using these systems contributes significantly to achieving more LEED building certification credits.

Variable flow systems

The Rhoss VPF solution can be summarised as follows:

The primary circuit pump or double pump is inverter-controlled to regulate the flow and thereby reduce pumping power [$P = f(Q^3)$].

The customer provides the inverter pump/pumps to control the secondary one. VPF testing in the Rhoss R&D Lab, regardless of the solution, has shown that the amount of water is important to stabilise operation and reduce how often the cooling unit turns ON/OFF. A primary side external tank (TANK) is recommended, connected to the unit, with a minimum volume of 5 l/kW or less if the Tank&Pump inside the unit is used.

Using 2-way "V2" valves for the terminals and a minimum number of 3-way "V3" valves is recommended to ensure a 20% minimum flow when the terminals are closed.

The set up for managing the variable flow rate, VPF_R, is supplied in many product ranges and indicated in the technical data sheets of this catalogue.



VPF solution by RHOSS
the new plant engineering frontier
Download the complete document:

<http://www.rhoss.com/download>

Download the video:

<http://www.rhoss.com/download>



Rhoss VPF Solution (Variable Primary Flow)

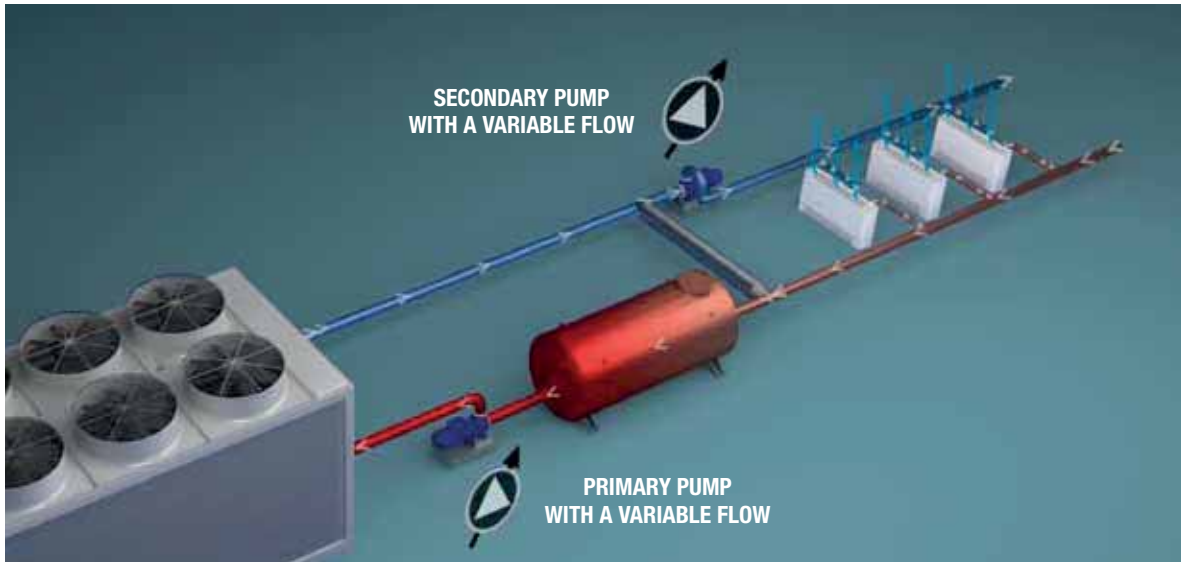

VPF RHOSS - The most efficient solution for variable flow systems

Comparison of the Rhoss VPF system and other pumping systems, when the load required changes. Annual savings are very high in terms of energy and costs, in the Mediterranean area as well as in Central European cities, which are applicable to 100 kW cooling units installed in systems running 24/7 (hospitals, hotels, etc.). The table indicates another important fact: the equivalent area of the photovoltaic system required to produce the electrical kW/h saved by the Rhoss system. This index shows how effective the proposed solution is.

	Annual energy consumed for pumping	Rhoss system savings	Surface area of photovoltaic system required to achieve the same savings as with the Rhoss system
	[kW/h]	[kW/h]	[m ²]
Primary constant flow and constant secondary	14.903	86%	81
Primary constant flow and variable secondary	7.472	71%	34
Conventional VPF system	5.442	60%	21
Rhoss VPF system	2.166		

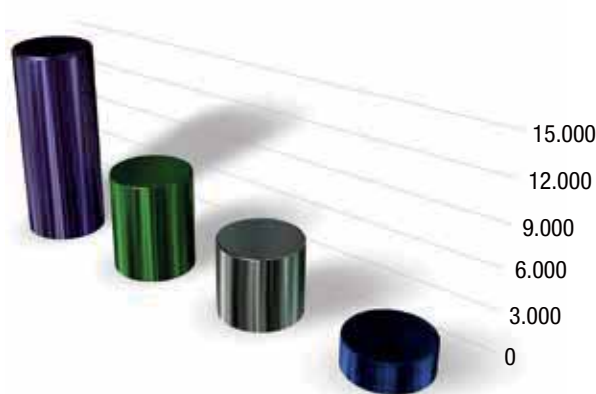

* Example of comparative results for 100 kW cooling unit installed in the plant with a variable load operating 24 hours a day (hospitals, hotels, etc.) in the northern Italy and central Europe climatic area.



- Primary constant flow and constant secondary
- Primary constant flow and variable secondary
- Traditional VPF system
- Conventional VPF system

Advantages of the RHOSS VPF solution:

1 A stable, functional solution for system adjustment

2 Energetically advantageous solution with real pumping energy savings

3 Safe solution for the chiller

4 Validated solution even with multiple chillers connected in parallel

Readily available Rhoos solutions

UpToDate is the ideal tool for selecting the Rhoos product range and verify the technical data of each model. The integrated calculation engine requires the verification of feasibility of the proposed solution, the selection and technical dimensioning of the catalogue models.

A unique and fast way to always find the ideal solution for any application together with the high technology proposed by Rhoos products.

- Comprehensive instruments for choosing Rhoos products suitable for your needs.
- Fast search of Rhoos products.
- Always updated on the latest news.
- Detailed technical reports in 7 languages.
- Chiller sorter also available on tablets and smartphones as a WEB application.

CHILLER selection



Fan-coil and hydronic terminal selection

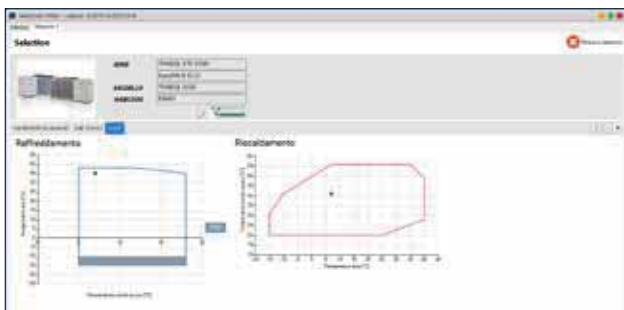

Utente: _____ Data: 30/11/2020

Riferimento: _____

SELEZIONE

Serie: EasyPACK ECO
 THAEQI 270-2150

Modello: THAEQI 2120

Webcode: EASQ2

Le immagini sono a puro scopo indicativo e possono non rappresentare esattamente i modelli e gli allestimenti oggetto del presente documento. Le prestazioni indicate confermano le prestazioni del software certificato di proprietà esclusiva dell'Ente e sono da non considerare come riferimento.

CARATTERISTICHE COSTRUTTIVE

Refrigeratori d'acqua e pompe di calore reversibili monoblocco con condensazione ad aria e ventilatori elicoidali.
 Serie a compressori ermetici scroll e refrigerante R32.
 Q: Versione supercondensata con investimento focalizzante dei compressori e ventilatori a velocità ridotta

ALIMENTAZIONE ELETTRICA: 400V/3PH/50HZ
 TIPO BATTERIE: BRA - BATTERIA RAME ALLUMINIO
 CONTROLLO CONDENSAGIONE: FC-CONTROLLO DI COND.
 VALV. ESPANSIONE ELETTRICA: EV-VALVOLA SPARSA ELETTRONICA
 FIMTURA DE: TQE - TETTO Q.E.
 OTTIMIZZAZIONE SFRONZATA: EO - OTTIMIZZAZIONE PER
 RIVESTIMENTO INCONGRUANTE: INS-INSONORIZZAZIONE COMPRESS.
 VERSIONI: 10/11/12/13/14/15/16/17/18/19/20/21/22/23/24/25/26/27/28/29/30/31/32/33/34/35/36/37/38/39/40/41/42/43/44/45/46/47/48/49/50/51/52/53/54/55/56/57/58/59/60/61/62/63/64/65/66/67/68/69/70/71/72/73/74/75/76/77/78/79/80/81/82/83/84/85/86/87/88/89/90/91/92/93/94/95/96/97/98/99/100

UP-TO-DATE

Report

Nome: _____ Data: 30/11/2020

Referimento: _____

Le immagini sono a puro scopo indicativo e possono non rappresentare esattamente i modelli e gli allestimenti oggetto del presente documento. Le prestazioni indicate confermano le prestazioni del software certificato di proprietà esclusiva dell'Ente e sono da non considerare come riferimento.

CARATTERISTICHE COSTRUTTIVE

Refrigeratori d'acqua e pompe di calore reversibili monoblocco con condensazione ad aria e ventilatori elicoidali.
 Serie a compressori ermetici scroll e refrigerante R32.
 Q: Versione supercondensata con investimento focalizzante dei compressori e ventilatori a velocità ridotta

ALIMENTAZIONE ELETTRICA: 400V/3PH/50HZ
 TIPO BATTERIE: BRA - BATTERIA RAME ALLUMINIO
 CONTROLLO CONDENSAGIONE: FC-CONTROLLO DI COND.
 VALV. ESPANSIONE ELETTRICA: EV-VALVOLA SPARSA ELETTRONICA
 FIMTURA DE: TQE - TETTO Q.E.
 OTTIMIZZAZIONE SFRONZATA: EO - OTTIMIZZAZIONE PER
 RIVESTIMENTO INCONGRUANTE: INS-INSONORIZZAZIONE COMPRESS.
 VERSIONI: 10/11/12/13/14/15/16/17/18/19/20/21/22/23/24/25/26/27/28/29/30/31/32/33/34/35/36/37/38/39/40/41/42/43/44/45/46/47/48/49/50/51/52/53/54/55/56/57/58/59/60/61/62/63/64/65/66/67/68/69/70/71/72/73/74/75/76/77/78/79/80/81/82/83/84/85/86/87/88/89/90/91/92/93/94/95/96/97/98/99/100



Electa-ECO - THAITI 106÷116

Electa-ECOS-B - MHAITI 104÷110 + IUB 06-10

Electa-ECOS-T - MHAITI 104÷110 + IUT 06-10

Electa-SAN - TWCZ 200-300

Mini-Y NF - THAEY 105÷111 NF

MidiPACK-I - TCAITY-THAITY 120÷130

Compact-Y NF Plus - THAEY 115÷127 NF

Compact-Y SM - THAEY 122÷130

MidiPACK-I ECO - TCAITI-THAITI 131÷155

MidiPACK-I - TCAITY-THAITY 138÷262

Compact-Y MD - TCAEY 238÷265 / THAEY 233÷265

POKER - THAEY 234 H.T.

EasyPACK ECO - TCAEI-THAEI 270÷2150

EasyPACK-I - TCAIY-THAIY 270÷2130

EasyPACK - TCAEY-THAEY 269÷2146

WinPACK HE-A - TCAEY-THAEY 2110÷4340

WinPACK SE - TCAEY-THAEY 2110÷4340

WinPACK-R HE-A - TCAETY-TCAEQY 4235÷4370

WinPACK-R SE - TCAEBY-TCAESY 4225÷4345

Y-Pack FREECOOLING - TFAEY-TGAEY 4160÷4320

WinPOWER ECO - TCAEU-THAEU 4370÷6660

WinPOWER HE-A - TCAEY 4385÷8920 / THAEY 4385÷6700

WinPOWER SE - TCAEY 4360÷8860

FullPOWER VFD - TCAITZ-TCAIQZ 2565÷21005

FullPOWER VFD (1+i) - TCAITZ-TCAIQZ 2560÷21310

FullPOWER HE-A - TCAVTZ-TCAVQZ 2345÷21335

FullPOWER SE - TCAVBZ 2335÷21275

Z-Power SE - TCAVZ 21400÷21600

Z-Power FREECOOLING - TFAVBZ - TFAVIZ - TFAVSZ 2420÷21100

TurboPOWER - TCATBZ-TCATTZ 1300÷31100 / TCATQZ 1300÷3990

TurboPOWER ECO - TCATTE-TCATQE 1330÷3950



CHILLERS - HEAT PUMPS

Air cooled - Axial fans

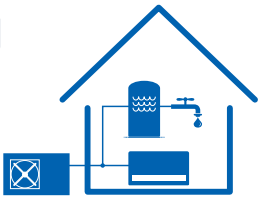

Electa-ECO

THAITI 106÷116

Cooling capacity: 4-13 kW - Heating capacity: 6-15.5 kW

INVERTER



Touch-screen control panel as standard



Electa-ECO
THAITI 106-108



Electa-ECO THAITI
110-114-116

- Low GWP R32 refrigerant
- Energy class A+++ / A++
- Temperature of the produced water up to 60°C
- Domestic hot water production from -25°C to +45°C outdoor air
- 3-way diverter valve management for DHW
- Touch-screen control panel as standard
- APP for managing the unit via smartphone (iOS and Android)

Packaged reversible air-cooled heat pumps with axial fans. Range with hermetic rotary DC Inverter compressors and R32 refrigerant gas.

Construction features

- Compressor: hermetic, twin rotary DC Inverter with steam injection, complete with thermal protection and casing heater
- Expansion valve: electronic.
- Cooling circuit with economiser
- Water side heat exchanger: adequately insulated stainless steel plates, complete with antifreeze heater.
- Air side heat exchanger: finned coil with copper pipes and aluminium-manganese fins with Golden Fin anti-corrosion treatment in epoxy resin and hydrophilic treatment.
- Fan: axial type impeller with DC brushless motors, equipped with internal thermal protection, accident protection grilles and proportional electronic device for continuous fan rotation speed regulation.
- Structure: made of galvanised and painted steel plate RAL9002, complete with condensate drain pan and unit base antifreeze heater.
- Control: microprocessor electronic control with touch-screen control panel with remote control option, for integrated management of the heat pump and the heating system, according to the various requirements relating to the use of the energy sources.
 - 3-way diverter valve management for production of domestic hot water.
 - Rapid heating function for domestic hot water.
 - Anti-legionella cycle function, with activation timer.
 - Auxiliary or supplementary heat source management.
 - Operation in silent mode with timer.
 - Weekly and daily time bands.
 - Holiday mode and antifreeze function.
 - Power consumption limiting function.

- 2-way on/off valve management for shutting off a part of the system, in heating or cooling mode.
- Management through room thermostat, as an alternative to the touch-screen panel.
- Unit activation from external contact (remote ON/OFF)
- Unit complete with:
 - Outdoor temperature probe for set-point compensation.
 - Remote ambient air temperature probe, for managing the unit according to the ambient set-point (10 m).
 - Water temperature probe for domestic hot water tank (20 m).
 - Water temperature probe for auxiliary or supplementary heat source (5 m).
 - Connection cable for touch-screen (8 m).
- RS485 interface for serial communication with other devices (Modbus RTU protocol).
- iOS and Android APP for managing the unit via smartphone and tablet.

Version

- T - High efficiency.

Models

- THAITI: heat pump unit.

PUMP set-up

- Pump unit complete with: EC circulator, automatic air vent valve, safety valve, flow switch, expansion tank, water filter.

Separately supplied accessories

- KVDEV - 3-way valve for the production of domestic hot water, managed by regulation.
- KRIT - Supplementary electrical resistance.
- KSA - Rubber anti-vibration mounts.
- KPRT - 20 m touch-screen connection cable as an alternative to the cable supplied as standard.



THAITI MODEL		106 M	108 M	110 M	114 M	116 M	116 T
① Heating capacity	kW	6	7,5	10	14	15,5	15,5
① Absorbed power	kW	1,58	2,0	2,7	4,18	4,7	4,7
① C.O.P.		3,8	3,75	3,7	3,35	3,3	3,3
② Heating capacity	kW	6	7,5	10	14	15,5	15,5
② Absorbed power	kW	1,2	1,63	2,17	3,22	3,6	3,6
② C.O.P.		5	4,6	4,61	4,35	4,31	4,3
③ Cooling capacity	kW	4	5	7,8	12	13	13
③ Absorbed power	kW	1,29	1,61	2,48	4,14	4,91	4,73
③ E.E.R.		3,1	3,1	3,15	2,9	2,65	2,75
④ Sound pressure	dB(A)	38	39	43	44	46	46
③ Available circulator head	kPa	69	66	77	50	42	42
Electrical supply	V-ph-Hz	230-1-50	230-1-50	230-1-50	230-1-50	230-1-50	400-3+N-50
DIMENSIONS AND WEIGHTS		106 M	108 M	110 M	114 M	116 M	116 T
L - Width	mm	1150	1150	1200	1200	1200	1200
H - Height	mm	758	758	878	878	878	878
P - Depth	mm	345	345	460	460	460	460
⑤ Weight	kg	109	109	166	166	166	166

Data at the following conditions:

- ① Air: 7°C D.B. - 6°C W.B. - Water: 40/45°C.
- ② Air: 7°C D.B. - 6°C W.B. - Water: 30/35°C.
- ③ Air: 35°C D.B. - Water: 12/7°C.
- ④ In open field (Q = 2) at 5 m from the unit.
- ⑤ Weight refers to the most complete set up.

Performance according to EN 14511

SEASONAL ENERGY PERFORMANCE		106 M	108 M	110 M	114 M	116 M	116 T
THAITI MODEL SEASONAL PERFORMANCE IN HEATING MODE - Low temperature application 35°C							
③ Pdesignh (EN 14825)	kW	5	6	9	11	13	13
③ SCOP (EN 14825)		4,7	4,65	4,48	4,28	4,18	4,18
④ η_s	%	185	183	176	168	164	164
④ Energy class		A+++	A+++	A+++	A+++	A++	A++
THAITI MODEL SEASONAL PERFORMANCE IN HEATING MODE - Medium temperature application 55°C							
③ Pdesignh (EN 14825)	kW	6	7	8	11	13	13
③ SCOP (EN 14825)		3,23	3,25	3,23	3,2	3,2	3,2
④ η_s	%	126	127	126	125	125	125
④ Energy class		A++	A++	A++	A++	A++	A++

③ In Average climatic conditions.

④ Seasonal energy efficiency: ambient heating in Average climate (EU Regulations No.811/2013 and No.813/2013)

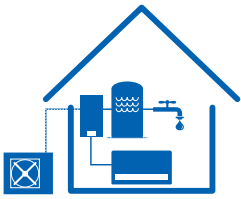

Electa-ECOS-B

MHAITI 104÷110 + IUB 06-10

Cooling capacity: 3.2-6.5 kW - Heating capacity: 4-9.5 kW

INVERTER



- Low GWP R32 refrigerant
- Energy class A+++
- Temperature of the produced water up to 60°C
- Domestic hot water production from -25°C to +45°C outdoor air
- Indoor unit complete with circulator, expansion tank, 3-way valve for DHW and electrical resistance.
- Touch-screen control panel.
- APP for managing the unit via smartphone (iOS and Android)

Two-section reversible air-water heat pumps.

Range with hermetic rotary DC Inverter compressors and R32 refrigerant gas.

Construction features

MHAITI outdoor unit

- Compressor: hermetic, twin rotary DC Inverter with steam injection, complete with thermal protection and casing heater
- Expansion valve: electronic.
- Cooling circuit with economiser
- Air side heat exchanger: finned coil with copper pipes and aluminium-manganese fins with Golden Fin anti-corrosion treatment in epoxy resin and hydrophilic treatment, complete with protection grilles.
- Fan: axial type impeller with DC brushless motors, equipped with internal thermal protection, accident protection grilles and proportional electronic device for continuous fan rotation speed regulation.
- Structure: made of galvanised and painted steel plate RAL9002, complete with condensate drain pan and unit base antifreeze heater.

IUB indoor unit

Hydronic module for wall mounting installation:

- Structure: made of galvanised and painted steel plate.
- Water side heat exchanger: adequately insulated stainless steel plates, complete with antifreeze heater.
- Pump unit complete with: EC circulator, automatic air vent valve, safety valve, flow switch, expansion tank, pressure gauge, water filter.
- 3-way valve for the production of domestic hot water.
- Supplementary electrical resistance, system side.
- Control: microprocessor electronic control with touch-screen panel for integrated management of the heat pump and the heating system, according to the various requirements relating to the use of the energy sources:
 - 3-way diverter valve management for production of domestic hot water.
 - Rapid heating function for domestic hot water.

- Anti-legionella cycle function, with activation timer.
- Auxiliary or supplementary heat source management.
- Operation in silent mode with timer.
- Weekly and daily time bands.
- Holiday mode and antifreeze function.
- Power consumption limiting function.
- 2-way on/off valve management for shutting off a part of the system, in heating or cooling mode.
- Management through room thermostat, as an alternative to the touch-screen panel.
- Unit activation from external contact (remote ON/OFF)
- Unit complete with:
 - Outdoor temperature probe for set-point compensation.
 - Remote ambient air temperature probe, for managing the unit according to the ambient set-point.
 - Water temperature probe for domestic hot water tank (20 m).
 - Communication cable between outdoor and indoor units.
- RS485 interface for serial communication with other devices (Modbus RTU protocol).
- iOS and Android APP for managing the unit via smartphone and tablet.

Version

T - High efficiency.

Models

MHAITI+USB: 2-section air-water heat pump.

Separately supplied accessories

KSA - Rubber anti-vibration mounts.



MHAITI outdoor unit		104	106	108	110
IUB indoor unit		06	06	10	10
① Heating capacity	kW	4	5,9	8	9,5
① Absorbed power	kW	1,02	1,51	2,14	2,64
① C.O.P.		3,92	3,91	3,74	3,6
② Heating capacity	kW	4	6	8	9,5
② Absorbed power	kW	0,78	1,2	1,7	2,07
② C.O.P.		5,13	5,00	4,71	4,59
③ Cooling capacity	kW	3,2	4,1	5,3	6,5
③ Absorbed power	kW	0,94	1,28	1,73	2,27
③ E.E.R.		3,42	3,2	3,06	2,86
④ Cooling capacity	kW	3,8	5,8	7,0	8,5
④ Absorbed power	kW	0,82	1,32	1,75	2,24
④ E.E.R.		4,63	4,40	4,00	3,79
⑤ Sound pressure (external unit)	dB(A)	37	37	41	42
③ Available circulator head	kPa	76	74	70	63
Electrical supply	V-ph-Hz	230-1-50	230-1-50	230-1-50	230-1-50
Internal unit electrical resistance	no. x kW	2 x 1,5	2 x 1,5	2 x 3,0	2 x 3,0
Refrigeration lines max length/height difference	m / m	20 / 15	20 / 15	25 / 15	25 / 15
MHAITI outdoor unit		104	106	108	110
L - Width	mm	975	975	980	980
H - Height	mm	702	702	788	788
P - Depth	mm	396	396	427	427
Weight	kg	55	55	82	82
IUB indoor unit		06	06	10	10
L - Width	mm	460	460	460	460
H - Height	mm	860	860	860	860
P - Depth	mm	315	315	315	315
Weight	kg	62	62	62	62

Data at the following conditions:

- ① Air: 7°C D.B. - 6°C W.B. - Water: 40/45°C.
 - ② Air: 7°C D.B. - 6°C W.B. - Water: 30/35°C.
 - ③ Air: 35°C D.B. - Water: 12/7°C.
 - ④ Air: 35°C D.B. - Water: 23/18°C.
 - ⑤ In open field (Q = 2) at 5 m from the unit.
 - ⑥ Weight refers to the most complete set up.
- Performance according to EN 14511

ENERGY PERFORMANCE		MHAITI	104	106	108	110
		IUB	06	06	10	10
AMBIENT HEATING - Low temperature application 35°C						
③ Pdesignh (EN 14825)	kW		5	6	7	9
③ SCOP (EN 14825)			4,66	4,54	4,60	4,60
④ η_s	%		184	179	181	181
④ Energy class			A+++	A+++	A+++	A+++
AMBIENT HEATING - Average application temperature 55°C						
③ Pdesignh (EN 14825)	kW		5	5	7	8
③ SCOP (EN 14825)			3,27	3,25	3,31	3,25
④ η_s	%		128	127	129	127
④ Energy class			A++	A++	A++	A++

- ③ In Average climatic conditions.
- ④ Seasonal energy efficiency: ambient heating in Average climate (EU Regulations No.811/2013 and No.813/2013)

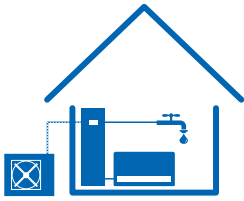

Electa-ECOS-T

MHAITI 104÷110 + IUT 06-10

Cooling capacity: 3.1-6.5 kW - Heating capacity: 4-9.5 kW

INVERTER



- Low GWP R32 refrigerant
- Energy class A+++
- Temperature of the produced water up to 60°C
- Domestic hot water production from -25°C to +45°C outdoor air
- Floor indoor unit complete with circulator, expansion tank, 3-way valve, DHW tank and electrical resistance.
- Touch-screen control panel.
- APP for managing the unit via smartphone (iOS and Android)



Two-section reversible air-water heat pumps with integrated tank for domestic hot water.

Range with hermetic rotary DC Inverter compressors and R32 refrigerant gas.

Construction features

MHAITI outdoor unit

- Compressor: hermetic, twin rotary DC Inverter with steam injection, complete with thermal protection and casing heater
- Expansion valve: electronic.
- Cooling circuit with economiser
- Air side heat exchanger: finned coil with copper pipes and aluminium-manganese fins with Golden Fin anti-corrosion treatment in epoxy resin and hydrophilic treatment.
- Fan: axial type impeller with DC brushless motors, equipped with internal thermal protection, accident protection grilles and proportional electronic device for continuous fan rotation speed regulation.
- Structure: made of galvanised and painted steel plate RAL9002, complete with condensate drain pan and unit base antifreeze heater.

IUT indoor unit

Hydronic module for floor installation:

- Structure: made of galvanised and painted steel plate.
- Water side heat exchanger: adequately insulated stainless steel plates, complete with antifreeze heater.
- Pump unit complete with: EC circulator, automatic air vent valve, safety valve, flow switch, expansion tank, pressure gauge, water filter.
- 3-way valve for the production of domestic hot water.
- Supplementary electrical resistance, system side.
- Domestic hot water buffer tank, complete with water temperature probe, anode and electrical resistance (3 kW).
- Control: electronic with microprocessor and touch-

screen control panel for integrated management of the heat pump and the heating system, according to the various requirements relating to the use of the energy sources:

- Domestic hot water production.
- Rapid heating function for domestic hot water.
- Anti-legionella cycle function, with activation timer.
- Auxiliary or supplementary heat source management.
- Operation in silent mode with timer.
- Weekly and daily time bands.
- Holiday mode and antifreeze function.
- Power consumption limiting function.
- 2-way on/off valve management for shutting off a part of the system, in heating or cooling mode.
- Management through room thermostat, as an alternative to the touch-screen panel.
- Unit activation from external contact (remote ON/OFF).
- Unit complete with:
 - Outdoor temperature probe for set-point compensation.
 - Remote ambient air temperature probe, for managing the unit according to the ambient set-point.
 - Communication cable between outdoor and indoor units.
- RS485 interface for serial communication with other devices (Modbus RTU protocol).
- iOS and Android APP for managing the unit via smartphone and tablet.

Version

T - High efficiency.

Models

MHAITI+IUT: 2-section air-water heat pump.

Separately supplied accessories

KSA - Rubber anti-vibration mounts.



MHAITI outdoor unit		104	106	108	110
IUT indoor unit		06	06	10	10
① Heating capacity	kW	4	5,9	8	9,5
① Absorbed power	kW	1,02	1,51	2,14	2,64
① C.O.P.		3,92	3,91	3,74	3,6
② Heating capacity	kW	4	6	8	9,5
② Absorbed power	kW	0,78	1,2	1,7	2,07
② C.O.P.		5,13	5,00	4,71	4,59
③ Cooling capacity	kW	3,2	4,1	5,3	6,5
③ Absorbed power	kW	0,94	1,28	1,73	2,27
③ E.E.R.		3,42	3,2	3,06	2,86
④ Cooling capacity	kW	3,8	5,8	7,0	8,5
④ Absorbed power	kW	0,82	1,32	1,75	2,24
④ E.E.R.		4,63	4,40	4,00	3,79
⑤ Sound pressure (external unit)	dB(A)	37	37	41	42
③ Available circulator head	kPa	73	70	66	58
DHW tank capacity	l	185	185	185	185
Electrical supply	V-ph-Hz	230-1-50	230-1-50	230-1-50	230-1-50
Internal unit electrical resistance	kW	2 x 1,5	2 x 1,5	2 x 3,0	2 x 3,0
Refrigeration lines max Height difference / length	m / m	20 / 15	20 / 15	25 / 15	25 / 15
DIMENSIONS AND WEIGHTS					
MHAITI outdoor unit		104	106	108	110
L - Width	mm	975	975	980	980
H - Height	mm	702	702	788	788
P - Depth	mm	396	396	427	427
Weight	kg	55	55	82	82
IUT indoor unit		06	06	10	10
L - Width	mm	600	600	600	600
H - Height	mm	1750	1750	1750	1750
P - Depth	mm	600	600	600	600
Empty weight	kg	209	209	209	209

Data at the following conditions:

- ① Air: 7°C D.B. - 6°C W.B. - Water: 40/45°C.
 - ② Air: 7°C D.B. - 6°C W.B. - Water: 30/35°C.
 - ③ Air: 35°C D.B. - Water: 12/7°C.
 - ④ Air: 35°C D.B. - Water: 23/18°C.
 - ⑤ In open field (Q = 2) at 5 m from the unit.
 - ⑥ Weight refers to the most complete set up.
- Performance according to EN 14511

ENERGY PERFORMANCE		MHAITI	104	106	108	110
		IUT	06	06	10	10
AMBIENT HEATING - Average application temperature 55°C						
③ P _{designh} (EN 14825)	kW		5	5	7	8
③ SCOP (EN 14825)			3,27	3,25	3,31	3,25
④ η _s	%		128	127	129	127
④ Energy class			A++	A++	A++	A++
WATER HEATING						
Load profile			L	L	L	L
⑤ η _{wh}	%		101	101	89	89
⑤ Energy class			A	A	A	A

- ③ In Average climatic conditions.
- ④ Seasonal energy efficiency: ambient heating in Average climate (EU Regulations No.811/2013 and No.813/2013)
- ⑤ Water heating energy efficiency in Average climate (+7°C). (Regulations (EU) No.811/2013 and No.813/2013)

Electa-SAN

TWCZ 200-300

Capacity: 200-300 L



- **Renewable energy water heater**
- **Standard version and with additional coil for solar thermal**
- **Domestic hot water production up to 65°C (up to 75°C with supplementary electrical resistance)**
- **Heat pump operation with outdoor air temperature from -10°C to +43°C**
- **Contact for integration with photovoltaic system**

Air-water heat pump for the production of domestic hot water. Rotary hermetic compressor and R134a refrigerant gas.

Construction features

- Carbon steel tank with double layer vitrification and internal treatment according to standards DIN 4753-3 and UNI 10025.
- Anti-corrosion magnesium anode to ensure the durability of the tank.
- Condenser wrapped externally to the boiler, free from scaling and chiller liquid-water contamination.
- Auxiliary coil for use in combination with solar panels (TWCZ-S only)
- Thermal insulation in thick expanded polyurethane (PU) (45 mm).
- External coating in RAL7035 grey plastic material
- Acoustically insulated plastic top cover.
- High efficiency compressor with R134a refrigerant.
- Electronic expansion valve.
- Safety devices for high and low gas pressure.
- Electrical resistance available in the unit as a back-up (with an integrated safety thermostat at 90°C), which ensures hot water at a constant temperature even in extreme winter conditions.

Electronic control and user interface for unit management:

- Tank temperature display.
- Water set-point adjustment.
- Clock display and switch-on and shutdown timer.
- Electrical resistance management, in manual mode or in automatic integration.
- Anti-legionella cycle function, with activation timer.
- Defrost with automatic activation of supplementary electrical resistance.
- Indication of any alarms and malfunctions.
- ON-OFF contact to start the unit from an external switch.
- Contact for integration with a photovoltaic system: the temperature set is raised to the highest possible value, on photovoltaic inverter enabling.
- Option to manage domestic hot water recirculation or solar integration.

Version

- TWCZ-B: water heater with heat pump.
- TWCZ-S: water heater with heat pump and additional coil for solar thermal.

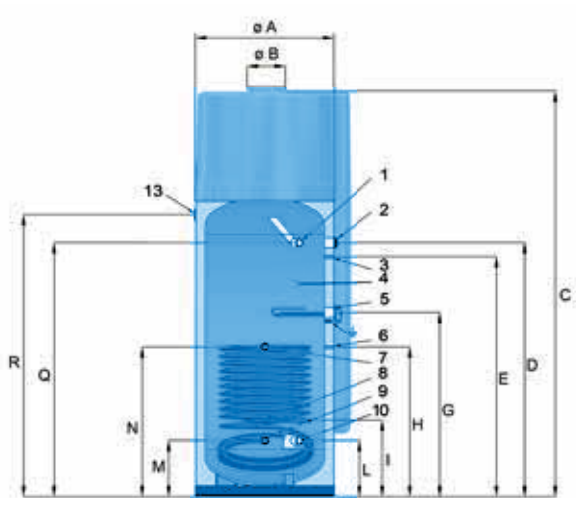

Model	A	B	C	D	E	G	H	I	L	M	N	Q	R
200	654	177	1638	1007	862	742	567	-	257	257	692	927	1063
300	654	177	1888	1177	1112	852	692	352	257	257	692	1177	1313

No.	TYPE OF CONNECTION	MODEL 200 - 300
1.	Hot water delivery	1"
2.	Anode	1"1/4
3.	Tank upp. temp. probe	ø 10
4.	Recirculation / Tank temp. auxiliary probe (model 200)	1/2"
5.	Electrical resistance	1"1/4
6.	Tank low. temp. probe	ø 10
7.	Solar energy delivery	1"
8.	Tank temp. auxiliary probe (model 300)	ø 10
9.	Solar energy return	1"
10.	Domestic cold water inlet	1"
13.	Condensate drain	ø 16



OUTDOOR

- Indoor installation

The unit is intended to be installed inside buildings in garages, utility rooms, basements, pantries, laundries or in other spaces inside the home, which are more favourable for operation than outdoor environmental conditions.

The layout of the air inlet and outlet connections makes the unit suitable for various connection modes, without ducting or with inlet/outlet ducting in a room adjacent to the unit.

As a secondary effect, during operation, the unit reduces the temperature and humidity of the environment in which the unit is installed or air is fed in.

SAFETY DISTANCES

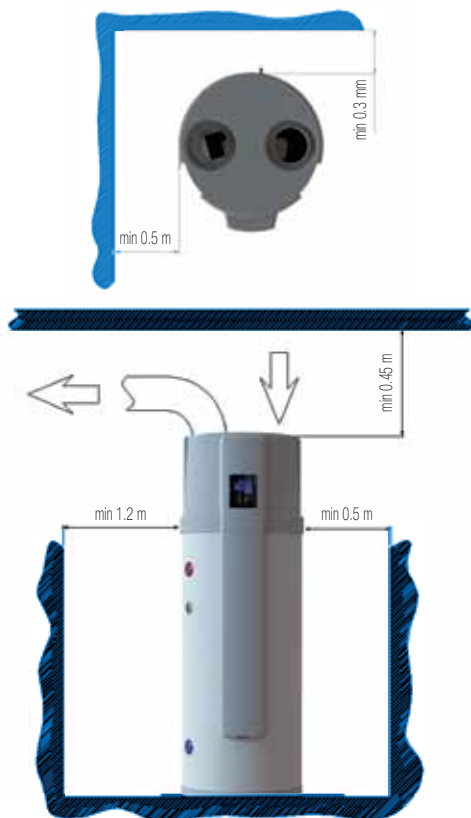

MINIMUM INSTALLATION ROOM VOLUME

The optimal working ambient temperature is 20°C.

If installed without an air exhaust duct, the installation room must have a minimum volume of 20 m³, with adequate ventilation.

MAXIMUM DUCT LENGTH

Duct diameter 160 mm: maximum length 4.3 m (intake+ejection without bends)

Duct diameter 180 mm: maximum length 8m (suction+ejection without bends)

OPERATING RANGE

	°C	TWCZ
Inlet air/working ambient temperature	-10÷43	
Water temperature	10÷65 (75*)	

*with supplementary electrical resistance



Electa-SAN

TWCZ 200-300

MODEL		TWCZ-B 200	TWCZ-B 300	TWCZ-S 200	TWCZ-S 300
Tank capacity	l	228	286	220	278
① Heating capacity	W	1870	1870	1870	1870
Absorbed power	W	503	503	503	503
Electrical resistance power	W	1200	1200	1200	1200
Maximum tank operating pressure	bar	10	10	10	10
② COPDHW		2,64	2,85	2,64	2,85
③ COPDHW		2,81	3,03	2,81	3,03
① Top-up times	h:min	05:38	06:57	05:38	06:57
① Top-up times with active resistance	h:min	03:03	03:46	03:03	03:46
② Maximum volume of DHW usable at 40°C	l	291	390	291	390
Solar thermal coil surface	m ²	-	-	1,2	1,2
Maximum solar coil operating pressure	bar	-	-	6	6
Nominal air flow	m ³ /h	450	450	450	450
Air flow rate at the maximum available static pressure 60 Pa	m ³ /h	350	350	350	350
Internal sound power	db(A)	58	58	58	58
④ Sound pressure	db(A)	43	43	43	43
Electrical supply	V-ph-Hz	230-1-50	230-1-50	230-1-50	230-1-50
Maximum absorbed power	W	765	765	765	765
Absorbed power in standby (Pes)	W	40	40	40	40
Protection rating	IP	IPX1	IPX1	IPX1	IPX1

Data at the following conditions:

- ① Air 20°C D.B. - 15°C W.B.; water from 15°C to 55°C.
- ② Air 7°C D.B. - 6°C W.B.; water from 10°C to 55°C (EN 16147).
- ③ Air 14°C D.B. - 12°C W.B.; water from 10°C to 55°C (EN 16147).
- ④ According to ISO 3744:2010 at 1 m from the unit

DIMENSIONS AND WEIGHTS

MODEL		TWCZ-B 200	TWCZ-B 300	TWCZ-S 200	TWCZ-S 300
L - Width	mm	655	655	655	655
H - Height	mm	1638	1888	1638	1888
P - Depth	mm	706	706	706	706
Empty weight	kg	112	122	127	137
Weight with a full water tank	kg	326	393	333	400

ENERGY PERFORMANCE

		TWCZ-B 200	TWCZ-B 300	TWCZ-S 200	TWCZ-S 300
WATER HEATING					
④ Load profile		L	XL	L	XL
④ η_{wh}	%	101	117	101	117
④ Energy class		A	A	A	A
④ Annual energy consumption	kWh/annum	1012	1426	1012	1426

- ④ Water heating energy efficiency in average climatic conditions (+7°C). (Regulations (EU) No.812/2013 and No.814/2013)

Mini-Y NF

THAEY 105÷111 NF

Cooling capacity: 5.6-11.3 kW - Heating capacity: 5.7-11.8 kW



- Compact units and Plug&Play
- Hot water up to -15°C outdoor air

Packaged reversible air-cooled heat pumps with axial fans. Range with scroll hermetic compressors and R410A refrigerant gas.

Construction features

- Compressor: hermetic, rotary scroll type, complete with thermal protection.
- Water side heat exchanger: adequately insulated stainless steel plates, complete with antifreeze heater and water flow differential pressure switch.
- Air side heat exchanger: featuring finned coil with copper pipes and aluminium fins with hydrophilic treatment and complete with protective mesh.
- Fan: external rotor axial type electric fans equipped with internal thermal protection, accident protection grilles and proportional electronic device for continuous fan rotation speed regulation.
- Control: microprocessor electronic control with Adaptive Function Plus logic.
- Structure: made of galvanised and painted steel plate, complete with condensate drain pan and unit base antifreeze heater.

Models

- THAEY: heat pump unit.

PUMP set-up

- Pump unit complete with: circulator, membrane expansion tank, manual air vent valve, safety valve.

TANK&PUMP set up

- Pump unit complete with: inertial buffer tank, circulator, membrane expansion tank, manual air vent valve, automatic air vent valve, safety valve.

Factory fitted accessories

- Soft-start device (for models with 230V power supply).
- Compressor casing heater.
- Digital input for double set-point.
- 4-20 mA analogue signal for shifting set-point.
- Low water set-point temperature.

Separately supplied accessories

- 3-way valve for the production of domestic hot water.
- Additional electrical resistance for heat pump, managed by regulation.
- Outdoor air temperature probe for set-point compensation.
- Rubber anti-vibration mounts.
- Water filter.
- Antifreeze heater on the tank.
- Remote keypad with display.
- Clock board.
- Interfaces for serial communication with other devices.
- Serial converter (RS485/USB).
- Rhoss supervisors for unit monitoring and remote management.



THEAY NF MODEL		105	107	109	111
① Heating capacity	kW	5,71	7,33	9,3	11,35/11,8
① Absorbed power	kW	2,19	2,84	3,5	4,65/5,65
① C.O.P.		2,61	2,58	2,66	2,44/2,09
② Heating capacity	kW	5,9	7,7	9,4	11,9/12,3
② Absorbed power	kW	1,68	2,07	2,63	3,30/3,30
② C.O.P.		3,52	3,72	3,58	3,61/3,73
③ Heating capacity	kW	3,8	4,6	6,1	7,3/7,3
③ Absorbed power	kW	1,65	2,13	2,69	3,35/3,38
③ C.O.P.		2,3	2,16	2,27	2,18/2,16
④ Cooling capacity	kW	5,6	7	9	10,9/11,3
④ E.E.R.		2,71	2,58	2,64	2,62/2,61
⑤ Sound pressure	dB(A)	46	47	47	47
Scroll/step compressor	no.	1/1	1/1	1/1	1/1
Buffer tank water content	l	19	19	30	30
④ Available circulator head	kPa	55	55	85	75
Electrical supply	V-ph-Hz	230-1-50	230-1-50 / 400-3+N-50	230-1-50 / 400-3+N-50	230-1-50 / 400-3+N-50
DIMENSIONS AND WEIGHTS		105	107	109	111
L - Width	mm	990	990	990	990
H - PUMP height	mm	905	905	1085	1085
H - TANK&PUMP height	mm	905	905	1295	1295
P - Depth	mm	380	380	380	380
⑥ Weight	kg	141	143	167	176

Data at the following conditions:

- ① Air: 7°C D.B. - 6°C W.B. - Water: 40/45°C.
 - ② Air: 7°C D.B. - 6°C W.B. - Water: 30/35°C.
 - ③ Air: -7°C D.B. - Water: 30/35°C.
 - ④ Air: 35°C D.B. - Water: 12/7°C.
 - ⑤ In open field (Q = 2) at 5 m from the unit.
 - ⑥ Weight refers to the most complete setup.
- Performance according to EN 14511

SEASONAL ENERGY PERFORMANCE		105	107	109	111
THEAY NF MODEL SEASONAL PERFORMANCE IN HEATING MODE					
③ Pdesignh (EN 14825)	kW	6	7	9	11
③ SCOP (EN 14825)		3,2	3,31	3,2	3,3
④ η_s	%	125	129	125	129
④ Energy class		A+	A+	A+	A+

- ③ In Average climatic conditions, low temperature application (35°C)
- ④ Seasonal energy efficiency: low temperature heating in Average climate (EU Regulations No.811/2013 and No.813/2013)

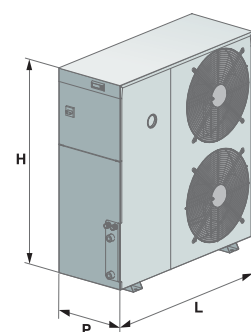

MidiPACK-I

TCAITY-THAITY 120÷130

Cooling capacity: 18.8-29.3 kW - Heating capacity: 20-30.4 kW

INVERTER



- Hot water up to -15°C outdoor air
- Temperature of the produced water up to 60°C
- Version with pump or with pump and storage tank
- Integrated MASTER/SLAVE control



Water chillers and packaged reversible air-cooled heat pumps with axial fans. Range with scroll hermetic compressors, DC Inverter and R410A refrigerant gas.

Construction features

- Compressor: scroll type, rotary, hermetic with Inverter actuation, complete with thermal protection and casing heater.
- Water side heat exchanger: adequately insulated stainless steel plates, complete with antifreeze heater and water flow differential pressure switch.
- Air side heat exchanger: featuring finned coil with copper pipes and aluminium fins for TCAITY with hydrophilic treatment for THAITY, complete with protection grilles.
- Fan: external rotor axial type electric fans equipped with internal thermal protection, accident protection grilles and proportional electronic device for continuous fan rotation speed regulation.
- Control: microprocessor electronic control with Adaptive Function Plus logic.
- Structure: made of galvanised and painted steel plate, complete with condensate drain pan and unit base antifreeze heater for THAITY.
- The unit is also complete with:
 - outdoor air temperature probe for set-point compensation;
 - electronic expansion valve;
 - display of cooling circuit high and low pressure;
 - Master/Slave control up to 4 units in parallel;
 - clock board.

Version

T - High efficiency.

Models

TCAITY: unit designed for cooling only.
THAITY: heat pump unit.



PUMP set-up

- Pump unit complete with: EC circulator with 3 speed selector or continuous speed regulation or electric pump, membrane expansion tank, manual air vent valve, safety valve and pressure gauge.

TANK&PUMP set up

- Pump unit complete with: inertial buffer tank, circulator or electric circulation pump, membrane expansion tank, manual air vent valve, safety valve, and pressure gauge.

Factory fitted accessories

- Forced Download. Compressor partialisation or switch-off to limit power and current consumption (digital input).
- Condensing control with fans with EC motor.
- Silenced set up.
- Antifreeze heater on the tank.
- Circulator/electric pump antifreeze heater.
- Pre-painted copper/coils or copper/copper coils.
- Digital input for double set-point.
- 4-20 mA analogue signal for shifting set-point.

Separately supplied accessories

- 3-way valve for the production of domestic hot water, managed by regulation.
- Additional electrical resistance for heat pump, managed by regulation.
- Remotely controllable outdoor air temperature probe for set-point compensation.
- Water filter.
- Rubber anti-vibration mounts.
- Remote keypad with display.
- Interfaces for serial communication with other devices.
- RS485/USB serial converter.
- Rhoss supervisors for unit monitoring and remote management.



TCAITY MODEL		120	125	130
❶ Cooling capacity	kW	18,8	25,2	29,3
❶ Absorbed power	kW	6,53	8,72	10,17
❶ E.E.R.		2,88	2,89	2,88
THAITY MODEL		120	125	130
❷ Heating capacity	kW	20	25,6	30,4
❷ Absorbed power	kW	6,15	7,83	9,5
❷ C.O.P. NOM		3,25	3,27	3,2
❸ Heating capacity	kW	21,1	26,1	30,7
❸ Absorbed power	kW	5,2	6,41	7,62
❸ C.O.P.		4,06	4,07	4,03
❹ Heating capacity	kW	14,8	18,1	21,3
❹ Absorbed power	kW	4,92	6,51	7,61
❹ C.O.P.		3,01	2,78	2,8
❶ Cooling capacity	kW	18,5	24,1	28,3
❶ E.E.R.		2,7	2,75	2,71
TCAITY-THAITY MODEL		120	125	130
❺ Sound pressure	dB(A)	47	50	51
❶ PO circulator available head	kPa	77	80	67
Buffer tank water content	l	110	110	110
Electrical supply	V-ph-Hz	400-3+N-50	400-3+N-50	400-3+N-50
DIMENSIONS AND WEIGHT		120	125	130
L - PUMP width	mm	1522	1522	1522
L - TANK&PUMP width	mm	1625	1625	1625
H - PUMP height	mm	1280	1280	1280
H - TANK&PUMP height	mm	1590	1590	1590
P - PUMP Depth	mm	600	600	600
P - TANK&PUMP Depth	mm	600	600	600
❻ PUMP Weight	kg	245	265	275
❻ TANK&PUMP Weight	kg	445	465	475

Data at the following conditions:

- ❶ Air: 35°C D.B. - Water: 12/7°C.
- ❷ Air: 7°C D.B. - 6°C W.B. - Water: 40/45°C.
- ❸ Air: 7°C D.B. - 6°C W.B. - Water: 30/35°C.
- ❹ Air: -7°C D.B. - Water: 30/35°C.
- ❺ In open field (Q = 2) at 5 m from the unit.
- ❻ Weight refers to the most complete setup.

Performance according to EN 14511. PO setup.

SEASONAL ENERGY PERFORMANCE		120	125	130
TCAITY MODEL SEASONAL PERFORMANCE IN COOLING MODE				
❶ P _{designc} (EN 14825)	kW	18,8	25,2	29,3
❶ SEER (EN 14825)		4,31	4,36	4,32
❷ η _{s,c}	%	169	171	170
THAITY MODEL SEASONAL PERFORMANCE IN HEATING MODE				
❸ P _{designh} (EN 14825)	kW	21	26	30
❸ SCOP (EN 14825)		4,17	3,63	3,88
❹ η _s	%	164	142	152
❹ Energy class		A++	A+	A++

- ❶ Low temperature application (7°C)
- ❷ Seasonal energy efficiency: low temperature cooling (EU Regulation 2016/2281)
- ❸ In Average climatic conditions, low temperature application (35°C)
- ❹ Seasonal energy efficiency: low temperature heating in Average climate (EU Regulations No.811/2013 and No.813/2013)

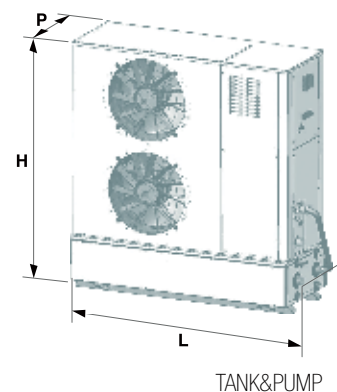

Compact-Y NF Plus

THAETY 115÷127 NF

Cooling capacity: 15.5-26.6 kW - Heating capacity: 16.6-30.4 kW



- Hot water up to -15°C outdoor air
- Temperature of the produced water up to 60°C
- Plug&Play unit with integrated hydraulic module
- Included evaporating/condensing control

Packaged reversible air-cooled heat pumps with axial fans. Range with scroll hermetic compressors and R410A refrigerant gas.

Construction features

- Compressor: hermetic, rotary scroll compressor, complete with thermal protection and casing heater for mod. 127.
- Water side heat exchanger: adequately insulated stainless steel plates, complete with antifreeze heater and water flow differential pressure switch.
- Air side heat exchanger: featuring finned coil with copper pipes and aluminium fins with hydrophilic treatment and complete with protection grille.
- Fan: external rotor axial type electric fans equipped with internal thermal protection, accident protection grilles and proportional electronic device for continuous fan rotation speed regulation.
- Control: microprocessor electronic control with Adaptive Function Plus logic.
- Structure: made of galvanised and painted steel plate, complete with condensate drain pan and unit base antifreeze heater.

Version

- T - High efficiency/temperature version.

Models

- THAETY: heat pump unit.

PUMP set-up

- Pump unit complete with: circulator or electric circulation pump, membrane expansion tank, manual air vent valve, safety valve and pressure gauge.

TANK&PUMP set up

- Pump unit complete with: inertial buffer tank, circulator or electric circulation pump, membrane expansion tank, manual air vent valve, automatic air vent valve, safety valve, and pressure gauge.

Factory fitted accessories

- Soft-start device.
- Silenced set up.
- Antifreeze heater on the tank.
- Compressor casing heater (mod. 115-124).
- Digital input for double set-point.
- 4-20 mA analogue signal for shifting set-point.
- Low water set-point temperature.

Separately supplied accessories

- 3-way valve for the production of domestic hot water, managed by regulation.
- Additional electrical resistance for heat pump, managed by regulation.
- Outdoor air temperature probe for set-point compensation.
- Rubber anti-vibration mounts.
- Water filter.
- Remote keypad with display.
- Clock board.
- Interfaces for serial communication with other devices.
- Serial converter (RS485/USB).
- Rhoss supervisors for unit monitoring and remote management.



THAETY NF MODEL		115	117	122	124	127
① Heating capacity	kW	16,6	17,7	23,4	25,9	30,4
① Absorbed power	kW	5,72	6,32	8,18	9,08	10,03
① C.O.P.		2,9	2,8	2,86	2,85	3,03
② Heating capacity	kW	18	19	24,8	27,8	32,3
② Absorbed power	kW	4,33	4,53	5,9	6,59	7,58
② C.O.P.		4,16	4,19	4,2	4,22	4,26
③ Heating capacity	kW	11,7	12	15,7	17,9	20,8
③ C.O.P.		2,77	2,77	2,8	2,77	2,84
④ Cooling capacity	kW	15,5	17,6	22,5	23,9	26,6
④ Absorbed power	kW	5,81	6,62	8,14	9,45	10,11
④ E.E.R.		2,67	2,66	2,75	2,53	2,63
⑤ Sound pressure	dB(A)	50	50	52	52	53
⑤ Silenced setup sound pressure	dB(A)	46	46	49	49	50
Scroll/step compressor	no.	1/1	1/1	1/1	1/1	1/1
Buffer tank water content	l	35	35	45	45	45
④ PO circulator/P1 electric pump nominal available head	kPa	75/147	64/136	66/131	69/130	63/116
Electrical supply	V-ph-Hz	400-3+N-50	400-3+N-50	400-3+N-50	400-3+N-50	400-3+N-50
DIMENSIONS AND WEIGHT		115	117	122	124	127
L - PUMP width	mm	1230	1230	1230	1230	1535
L - TANK&PUMP width	mm	1522	1522	1522	1522	1822
H - Height	mm	1090	1090	1280	1280	1510
P - Depth	mm	580	580	600	600	695
⑥ Weight	kg	215	225	278	288	320

Data at the following conditions:

- ① Air: 7°C D.B. - 6°C W.B. - Water: 40/45°C.
- ② Air: 7°C D.B. - 6°C W.B. - Water: 30/35°C.
- ③ Air: -7°C D.B. - Water: 30/35°C.
- ④ Air: 35°C D.B. - Water: 12/7°C.
- ⑤ In open field (Q = 2) at 5 m from the unit.
- ⑥ Weight refers to the most complete setup.

Performance according to EN 14511. Setup with circulator.

Important note:

- With circulator (PO/ASPO setup) the units are not suitable for radiant cooling operation.
- Permissible heat exchanger thermal gradient $\Delta T = 4-8^{\circ}\text{C}$.

SEASONAL ENERGY PERFORMANCE		115	117	122	124	127
THAETY NF MODEL SEASONAL PERFORMANCE IN HEATING MODE						
③ Pdesignh (EN 14825)	kW	18	18	24	27	32
③ SCOP (EN 14825)		3,62	3,74	3,72	3,74	3,68
④ η_s	%	142	146	146	146	144
④ Energy class		A+	A+	A+	A+	A+

③ In Average climatic conditions, low temperature application (35°C)

④ Seasonal energy efficiency: low temperature heating in Average climate (EU Regulations No.811/2013 and No.813/2013)

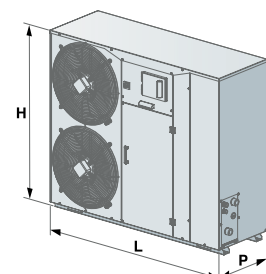

Compact-Y SM

THAEY 122÷130

Cooling capacity: 22.7-29 kW - Heating capacity: 23.5-34 kW



- **Plug&Play unit with integrated hydraulic module**

Packaged reversible air-cooled heat pumps with axial fans. Range with scroll hermetic compressors and R410A refrigerant gas.

Construction features

- Compressor: hermetic, rotary scroll compressor, complete with thermal protection and casing heater for mod. 127-130.
- Water side heat exchanger: adequately insulated stainless steel plates, complete with antifreeze heater and water flow differential pressure switch.
- Air side heat exchanger: finned coil with copper pipes and aluminium fins, complete with protection grilles.
- Fan: external rotor axial type electric fans equipped with internal thermal protection and accident protection grilles.
- Control: microprocessor electronic control with Adaptive Function Plus logic.
- Structure: in galvanised and painted steel plate, complete with condensate drain pan.

Models

- THAEY: heat pump unit.

PUMP set-up

- Pump unit complete with: circulator or electric circulation pump, membrane expansion tank, manual air vent valve, safety valve and pressure gauge.

TANK & PUMP set up

- Pump unit complete with: inertial buffer tank, circulator or electric circulation pump, membrane expansion tank, manual air vent valve, automatic air vent valve, safety valve, and pressure gauge.

Factory fitted accessories

- Soft-start device.
- Silenced set up.
- Condensing control.
- Antifreeze heater on the buffer tank.
- Compressor casing heater (mod. 122).
- Unit base antifreeze heater for operation in heat pump mode at low outdoor air temperatures.
- Digital input for double set-point
- 4-20 mA analogue signal for shifting set-point.
- Low water set-point temperature.
- Pre-painted copper/coils or copper/copper coils.

Separately supplied accessories

- Rubber anti-vibration mounts.
- Condensing control.
- Water filter.
- 3-way valve for the production of domestic hot water.
- Outdoor air temperature probe for set-point compensation.
- Additional electrical resistance for heat pump, managed by regulation.
- Remote keypad with display.
- Clock board.
- Interfaces for serial communication with other devices.
- Serial converter (RS485/USB).
- Rhoss supervisors for unit monitoring and remote management.



THAEY MODEL		122	127	130
① Heating capacity	kW	23,5	30,3	34
① Absorbed power	kW	7,94	10,16	11,25
① C.O.P.		2,96	3,02	3,02
② Heating capacity	kW	24	30,9	34,5
② C.O.P.		3,75	3,80	3,72
③ Cooling capacity	kW	22,7	26,7	29
③ Absorbed power	kW	7,99	10,23	11,84
③ E.E.R.		2,84	2,64	2,45
④ Sound pressure	dB(A)	52	53	53
④ Silenced setup sound pressure	dB(A)	49	50	50
Scroll/step compressor	n.	1/1	1/1	1/1
Circuits	no.	1	1	1
Buffer tank water content	l	45	45	45
③ Circulator/standard electric pump nominal available head	kPa	64/131	61/116	57/112
Electrical supply	V-ph-Hz	400-3+N-50	400-3+N-50	400-3+N-50
DIMENSIONS AND WEIGHT		122	127	130
L - PUMP width	mm	1230	1535	1535
W - TANK & PUMP width	mm	1522	1822	1822
H - Height	mm	1280	1510	1510
P - Depth	mm	600	695	695
⑤ THAEY weight	kg	278	320	380

Data at the following conditions:

- ① Air: 7°C D.B. - 6°C W.B. - Water: 40/45°C.
- ② Air: 7°C D.B. - 6°C W.B. - Water: 30/35°C.
- ③ Air: 35°C - Water: 12/7°C.
- ④ In open field (Q = 2) at 5 m from the unit.
- ⑤ Weight refers to the most complete setup.

Performance according to EN 14511. Setup with electric pump.

SEASONAL ENERGY PERFORMANCE		122	127	130
THAEY MODEL SEASONAL PERFORMANCE IN HEATING MODE				
③ Pdesignh (EN 14825)	kW	24	32	36
③ SCOP (EN 14825)		3,21	3,26	3,2
④ η_s	%	125	127	125
④ Energy class		A+	A+	A+

- ③ In Average climatic conditions, low temperature application (35°C)
- ④ Seasonal energy efficiency: low temperature heating in Average climate (EU Regulations No.811/2013 and No.813/2013)

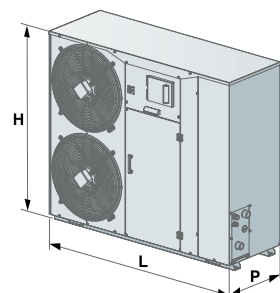

MidiPACK-I ECO

TCAITI-THAITI 131÷155

new

Cooling capacity: 29.5÷55.2 kW - Heating capacity: 32.4÷58.8 kW

INVERTER



- Efficient and eco-friendly unit in R32
- Hot water up to -15°C outdoor air
- Temperature of the produced water up to 60°C
- Plug&Play unit with integrated hydraulic module
- Optional EC fans and inverter-based circulation pump
- Integrated MASTER/SLAVE control



Water chillers and packaged reversible air-cooled heat pumps with axial fans.

Series with scroll hermetic compressors, DC Inverter and R32 refrigerant gas.

Construction features

- Compressor: scroll type, rotary, hermetic with Inverter actuation, complete with thermal protection and casing heater.
- Water side heat exchanger: adequately insulated stainless steel plates, complete with antifreeze heater and water flow differential pressure switch.
- Air side heat exchanger: finned coil with copper pipes and aluminium fins, complete with protection grilles.
- Fan: external rotor axial type electric fans equipped with internal thermal protection, accident protection grilles and proportional electronic device for continuous fan rotation speed adjustment.
- Control: microprocessor electronic control with Adaptive Function Plus logic.
- Structure: made of galvanised and painted steel plate
- The unit is also complete with:
 - outdoor air temperature probe for compensation of the Set-point;
 - display of cooling circuit high and low pressure;
 - electronic expansion valve;
 - Master/Slave control up to 4 units in parallel;
 - clock board.

Version

T - High efficiency.

Models

TCAITI: unit designed for cooling only.
THAITI: heat pump unit.

PUMP set up

Pump unit with single or double electric pump, including an automatic actuation pump in standby, complete with expansion tank, air vent valves, safety valve and water side pressure gauge. The pumps are available in low or high pressure head versions, and with INVERTER operation.

TANK&PUMP set up

- Pump unit complete with inertial buffer tank and single or double electric pump, including an automatic actuation pump in standby, complete with expansion tank, air vent valves, safety valve and water side pressure gauge. The pumps are available in low or high pressure head versions, and with INVERTER operation.

Factory fitted accessories

- Pre-painted copper/aluminium coils with hydrophilic treatment or copper/copper.
- Desuperheater.
- 100% heat recovery unit (only TCAITI)
- 3-way diverter valve for domestic hot water production, managed by the adjustment.
- Condensing control with fans with EC motor.
- Base antifreeze heater
- Antifreeze heater for buffer tank and electric pumps
- Forced Download. Compressor partialisation or switch-off to limit power and current consumption (digital input).
- Double safety valves.
- Refrigerant leak detector
- Digital input for double set-point.
- 4-20 mA analogue signal for shifting set-point.
- Energy parameters measurement.
- Silenced set up.
- Cooling circuit high and low pressure gauges.
- Low water set-point temperature.

Separately supplied accessories

- 3-way valve for the production of domestic hot water, managed by the adjustment.
- Remotely controllable outdoor air temperature probe for compensation of the Set-point.
- Additional electrical resistance for heat pump, managed by the adjustment.
- Rubber anti-vibration mounts.
- Water filter.
- Thermostat with display.
- Remote keypad with display.
- Interfaces for serial communication with other devices.
- Serial converter (RS485/USB).
- Rhoss supervisors for unit monitoring and remote management.



TCAITI MODEL		131	140	148	155
❶ Cooling capacity	kW	30,1	38,7	48	55,2
❶ Absorbed power	kW	10,13	13,07	15,84	18,46
❶ E.E.R.		2,97	2,96	3,03	2,99
THAITI MODEL		131	140	148	155
❷ Heating capacity	kW	32,4	42	53,2	58,8
❷ Absorbed power	kW	9,67	12,61	15,88	18,32
❷ C.O.P.		3,35	3,33	3,35	3,21
❸ Heating capacity	kW	32,9	42,9	53,8	59,5
❸ Absorbed power	kW	7,99	10,51	13,03	15,14
❸ C.O.P.		4,12	4,08	4,13	3,93
❹ Heating capacity	kW	22,8	29,1	36,9	40,9
❹ Absorbed power	kW	7,65	10	12,42	14,4
❹ C.O.P.		2,98	2,91	2,97	2,84
❶ Cooling capacity	kW	29,5	38,3	47,1	54
❶ E.E.R.		2,88	2,91	2,96	2,91
TCAITI-THAITI MODELS		131	140	148	155
❺ Sound pressure	dB(A)	51,5	53,5	54,5	55,5
Scroll compressor	no.	1-inverter	1-inverter	1-inverter	1-inverter
Circuits	no.	1	1	1	1
Buffer tank water content (TANK&PUMP)	l	150	150	150	150
❶ Standard head pump nominal available head (TCAITI)	kPa	129	122	116	110
Electrical supply	V-ph-Hz	400-3+N-50	400-3+N-50	400-3+N-50	400-3+N-50
DIMENSIONS AND WEIGHT		131	140	148	155
L - Width	mm	2315	2315	2315	2315
H - Height	mm	1580	1580	1580	1580
P - Depth	mm	1000	1000	1000	1000
❻ TCAITI weight	kg	450	470	480	490
❻ THAITI weight	kg	470	490	500	510

Data at the following conditions:

- ❶ Air: 35°C D.B. - Water: 12/7°C.
 - ❷ Air: 7°C D.B. - 6°C W.B. - Water: 40/45°C.
 - ❸ Air: 7°C D.B. - 6°C W.B. - Water: 30/35°C.
 - ❹ Air: -7°C D.B. - Water: 30/35°C.
 - ❺ In open field (Q = 2) at 5 m from the unit.
 - ❻ Weight referred to the unit without load and not accessorised.
- Performance according to EN 14511.

SEASONAL ENERGY PERFORMANCE		131	140	148	155
TCAITI MODEL SEASONAL PERFORMANCE IN COOLING MODE					
❶ Pdesignc (EN 14825)	kW	30,1	38,7	48	55,2
❶ SEER (EN 14825)		4,65	4,82	4,91	4,7
❷ ηs,c	%	183	190	193	185
THAITI MODEL SEASONAL PERFORMANCE IN HEATING MODE					
❸ Pdesignh (EN 14825)	kW	30	38	48	54
❸ SCOP (EN 14825)		3,9	3,91	3,95	3,9
❹ ηs	%	153	154	155	153
❹ Energy class		A++	A++	A++	A++

- ❶ Low temperature application (7°C)
- ❷ Seasonal energy efficiency: low temperature cooling (EU Regulation 2016/2281)
- ❸ In Average climatic conditions, low temperature application (35°C)
- ❹ Seasonal energy efficiency: low temperature heating in Average climate (EU Regulations No.811/2013 and No.813/2013)

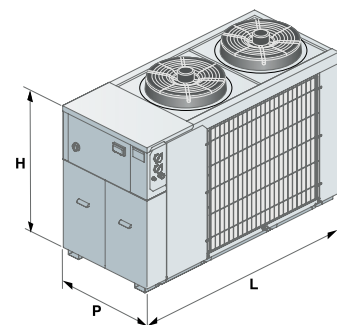

MidiPACK-I

TCAITY-THAITY 138÷262

Cooling capacity: 37.4-62.6 kW - Heating capacity: 40.2-71 kW

INVERTER



- Hot water up to -15°C outdoor air
- Temperature of the produced water up to 60°C
- Plug&Play unit with integrated hydraulic module
- Optional EC fans and inverter-based circulation pump
- Multi-purpose for systems with 2 pipes + DHW (with optional RC100)
- Integrated MASTER/SLAVE control



Water chillers and packaged reversible air-cooled heat pumps with axial fans.

Range with scroll hermetic compressors, DC Inverter and R410A refrigerant gas.

Construction features

- Compressor: scroll type, rotary, hermetic with Inverter actuation, complete with thermal protection and casing heater.
- Water side heat exchanger: adequately insulated stainless steel plates, complete with antifreeze heater and water flow differential pressure switch.
- Air side heat exchanger: finned coil with copper pipes and aluminium fins, complete with protection grilles.
- Fan: external rotor axial type electric fans equipped with internal thermal protection, accident protection grilles and proportional electronic device for continuous fan rotation speed regulation.
- Control: microprocessor electronic control with Adaptive Function Plus logic.
- Structure: made of galvanised and painted steel plate
- The unit is also complete with:
 - outdoor air temperature probe for set-point compensation;
 - display of cooling circuit high and low pressure;
 - electronic expansion valve;
 - Master/Slave control up to 4 units in parallel;
 - clock board.

Version

T - High efficiency.

Models

TCAITY: unit designed for cooling only.
THAITY: heat pump unit.

PUMP set-up

Pump unit with single or double electric pump, including an automatic actuation pump in standby, complete with expansion tank, air vent valves, safety valve and water side pressure gauge. The pumps are available in low or high pressure head versions, and with INVERTER operation.

TANK&PUMP set up

- Pump unit complete with inertial buffer tank and single or double electric pump, including an automatic actuation pump in standby, complete with expansion tank, air vent valves, safety valve and water side pressure gauge. The pumps are available in low or high pressure head versions, and with INVERTER operation.

Factory fitted accessories

- Pre-painted copper/aluminium coils with hydrophilic treatment or copper/copper.
- Desuperheater.
- 100% heat recovery unit.
- 3-way diverter valve for the production of domestic hot water, managed by regulation.
- Condensing control with fans with EC motor.
- Base antifreeze heater
- Antifreeze heater for buffer tank and electric pumps
- Forced Download. Compressor partialisation or switch-off to limit power and current consumption (digital input).
- Refrigerant leak detector
- Digital input for double set-point.
- 4-20 mA analogue signal for shifting set-point.
- Energy parameters measurement.
- Silenced set up.
- Cooling circuit high and low pressure gauges.

Separately supplied accessories

- 3-way valve for the production of domestic hot water, managed by regulation.
- Remotely controllable outdoor air temperature probe for set-point compensation.
- Additional electrical resistance for heat pump, managed by regulation.
- Rubber anti-vibration mounts.
- Water filter.
- Thermostat with display.
- Remote keypad with display.
- Interfaces for serial communication with other devices.
- Serial converter (RS485/USB).
- Rhoss supervisors for unit monitoring and remote management.



TCAITY MODEL		138	146	154	262
① Cooling capacity	kW	37,4	47,7	55,1	62,6
① Absorbed power	kW	13,6	16,1	18,4	22,8
① E.E.R.		2,76	2,97	2,99	2,75
THAITY MODEL		138	146	154	262
② Heating capacity	kW	40,2	52,1	58,7	71
② Absorbed power	kW	12,5	16,2	18,2	22,2
② C.O.P.		3,21	3,22	3,23	3,2
③ Heating capacity	kW	40,2	54,2	60,4	74
③ Absorbed power	kW	10,3	14,3	15,9	20,2
③ C.O.P.		3,91	3,8	3,81	3,67
④ Heating capacity	kW	28,3	38,6	42,3	51
④ Absorbed power	kW	9,7	13,4	14,9	19,5
④ C.O.P.		2,92	2,89	2,83	2,62
① Cooling capacity	kW	36,7	46,1	54	61,4
① E.E.R.		2,69	2,9	2,92	2,7
TCAITY-THAITY MODEL		138	146	154	262
⑤ Sound pressure	dB(A)	54	55	55	57
Scroll compressor	n.	1-inverter	1-inverter	1-inverter	1-inverter + 1
Circuits	no.	1	1	1	1
Buffer tank water content (TANK&PUMP)	l	80	150	150	150
① Standard head pump nominal available head (TCAITY)	kPa	124	98	107	111
Electrical supply	V-ph-Hz	400-3+N-50	400-3+N-50	400-3+N-50	400-3+N-50
DIMENSIONS AND WEIGHTS		138	146	154	262
L - Width	mm	1660	2315	2315	2315
H - Height	mm	1570	1570	1570	1570
P - Depth	mm	1000	1000	1000	1000
⑥ TCAITY weight	kg	540	635	695	825
⑥ THAITY weight	kg	550	655	725	845

Data at the following conditions:

- ① Air: 35°C D.B. - Water: 12/7°C.
- ② Air: 7°C D.B. - 6°C W.B. - Water: 40/45°C.
- ③ Air: 7°C D.B. - 6°C W.B. - Water: 30/35°C.
- ④ Air: -7°C D.B. - Water: 30/35°C.
- ⑤ In open field (Q = 2) at 5 m from the unit.
- ⑥ Weight refers to the most complete setup.
Performance according to EN 14511.

SEASONAL ENERGY PERFORMANCE		138	146	154	262
TCAITY MODEL SEASONAL PERFORMANCE IN COOLING MODE					
① Pdesignc (EN 14825)	kW	37,4	47,7	55,1	62,6
① SEER (EN 14825)		4,33	4,31	4,27	4,31
② ηs,c	%	170	169	168	169
THAITY MODEL SEASONAL PERFORMANCE IN HEATING MODE					
③ Pdesignh (EN 14825)	kW	40	54	60	75
③ SCOP (EN 14825)		3,9	3,85	3,84	4,19
④ ηs	%	153	151	150	165
④ Energy class		A++	A++	A++	-

- ① Low temperature application (7°C)
- ② Seasonal energy efficiency: low temperature cooling (EU Regulation 2016/2281)
- ③ In Average climatic conditions, low temperature application (35°C)
- ④ Seasonal energy efficiency: low temperature heating in Average climate (EU Regulations No.811/2013 and No.813/2013)

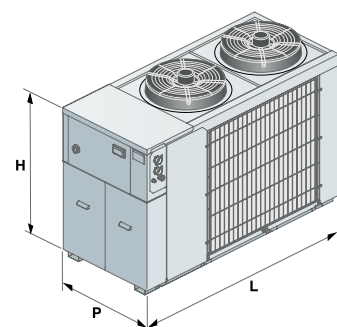

Compact-Y MD

TCAEY 238÷265 / THAEY 233÷265

Cooling capacity: 32.3-64.6 kW - Heating capacity: 37.8-68.3 kW



- **3 capacity steps (mod. 245-265)**
- **HT65 version for 65°C water production (°)**

Water chillers and packaged reversible air-cooled heat pumps with axial fans. Range with scroll hermetic compressors and R410A refrigerant gas.

Construction features

- Compressor: hermetic, rotary scroll type, complete with thermal protection and casing heater. 3 capacity steps with high efficiency at partial loads for models 245-265.
- Water side heat exchanger: adequately insulated stainless steel plates, complete with antifreeze heater and water flow differential pressure switch.
- Air side heat exchanger: finned coil with copper pipes and aluminium fins, complete with protection grilles.
- Fan: external rotor helical type electric fan equipped with internal thermal protection, accident protection grilles and proportional electronic device for continuous fan speed regulation.
- Control: microprocessor electronic control with Adaptive Function Plus logic.
- Structure: made of galvanised and painted sheet steel.

Models

- TCAEY: unit designed for cooling only.
- THAEY: heat pump unit.

PUMP set-up

- Pump unit complete circulator, single or double electric pump, including an automatic actuation pump in standby (mod. 245-265), expansion tank, air bleed valves, safety valve and water side pressure gauge.

TANK&PUMP set up

- Pump unit complete inertial buffer tank, circulator,

single or double electric pump, including an automatic actuation pump in standby (mod. 245-265), expansion tank, air bleed valves, safety valve and water side pressure gauge.

Factory fitted accessories

- Soft-start device.
- Silenced set up.
- 15% desuperheater.
- 100% heat recovery unit.
- Refrigerant circuit high and low pressure gauges (mod. 245-265).
- Buffer tank antifreeze heater.
- Electric pump antifreeze heater (mod. 245-265).
- Digital input for double set-point
- 4-20 mA analogue signal for shifting set-point.
- Low water set-point temperature.
- Pre-painted copper/coils or copper/copper coils.

Separately supplied accessories

- Outdoor air temperature probe for set-point compensation.
- Additional electrical resistance for heat pump, managed by regulation.
- Rubber anti-vibration mounts.
- Water filter.
- Remote keypad with display.
- Clock board.
- Interfaces for serial communication with other devices.
- Serial converter (RS485/USB).
- Rhoss supervisors for unit monitoring and remote management.



TCAEY MODEL (P1 set up)		233	238	245	250	260	265
❶ Cooling capacity	kW	-	39,4	44,8	51,9	59,8	64,6
❶ Absorbed power	kW	-	12,83	17,43	19,73	22,15	24,01
❶ E.E.R.		-	3,07	2,57	2,63	2,7	2,65
THAEY MODEL							
❷ Heating capacity	kW	37,8	42,1	48,1	56,2	62,6	68,3
❷ Absorbed power	kW	12,54	13,19	16,82	18,97	20,86	23,71
❷ C.O.P.		3,01	3,19	2,86	2,96	3	2,88
❶ Cooling capacity		32,3	38,5	42,3	50,3	57,8	61,6
❶ E.E.R.		2,59	2,95	2,49	2,68	2,64	2,54
TCAEY-THAEY MODEL		233	238	245	250	260	265
❸ Sound pressure	dB(A)	54	54	56	56	57	57
❸ Silenced setup sound pressure	dB(A)	51	51	53	53	54	54
Scroll/step compressor	n.	2/2	2/2	2/3	2/3	2/3	2/3
Circuits	no.	1	1	1	1	1	1
Buffer tank water content (TANK&PUMP)	l	80	150	150	150	150	150
❶ Available nominal head of standard electric pump (TCAEY)	kPa	106	87	113	102	87	74
Electrical supply	V-ph-Hz	400-3+N-50	400-3+N-50	400-3+N-50	400-3+N-50	400-3+N-50	400-3+N-50
DIMENSIONS AND WEIGHTS		233	238	245	250	260	265
L - Width	mm	1660	2315	2315	2315	2315	2315
H - Height	mm	1570	1570	1570	1570	1570	1570
P - Depth	mm	1000	1000	1000	1000	1000	1000
❷ TCAEY weight	kg	-	625	725	750	775	820
❷ THAEY weight	kg	475	645	745	770	795	840

Data at the following conditions:

- ❶ Air: 35°C - Water: 12/7°C.
 - ❷ Air: 7°C D.B. - 6°C W.B. - Water: 40/45°C.
 - ❸ In open field (Q = 2) at 5 m from the unit.
 - ❹ Weight refers to the most complete set up.
- Performance according to EN 14511

SEASONAL ENERGY PERFORMANCE		233	238	245	250	260	265
TCAEY MODEL SEASONAL PERFORMANCE IN COOLING MODE (P1 set up)							
❶ Pdesignc (EN 14825)	kW	-	39,4	44,8	51,9	59,8	64,6
❶ SEER (EN 14825)		-	4,26	4,24	4,35	4,31	4,27
❷ $\eta_{s,c}$	%	-	167	167	171	170	168
THAEY MODEL SEASONAL PERFORMANCE IN HEATING MODE							
❸ Pdesignh (EN 14825)	kW	36	41	49	56	62	70
❸ SCOP (EN 14825)		3,72	3,72	3,61	3,58	3,56	3,66
❹ η_s	%	146	146	141	140	140	144
❹ Energy class		A+	A+	A+	A+	A+	A+

- ❶ Low temperature application (7°C)
- ❷ Seasonal energy efficiency: low temperature cooling (EU Regulation 2016/2281)
- ❸ In Average climatic conditions, low temperature application (35°C)
- ❹ Seasonal energy efficiency: low temperature heating in Average climate (EU Regulations No.811/2013 and No.813/2013)

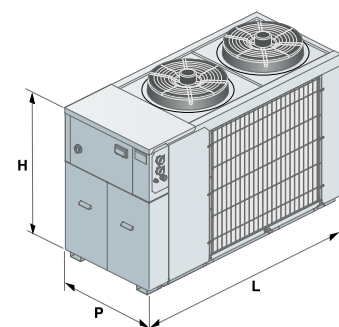

POKER

THAETY 234 H.T.

Cooling capacity: 28.8-115.2 kW - Heating capacity: 33.8-135.2 kW



- **Modular range: up to 4 units may be combined**
- **Total system redundancy with multiple modules installed**
- **Cascade management including DHW with multiple modules installed**
- **Hot water production from -20°C to 40°C outdoor air**
- **Temperature of the produced water up to 60°C**

Modular reversible heat pumps for high temperature water production, air cooled with axial fans. Range with scroll hermetic compressors and R410A refrigerant gas.

Construction features

- Compressors: hermetic scroll type rotary compressors with steam injection, thermal protection and casing heater.
- Water side heat exchanger: adequately insulated stainless steel plates, complete with antifreeze heater and water flow differential pressure switch.
- Air side heat exchanger: finned coil heat exchanger, with copper pipes and aluminium fins with hydrophilic treatment.
- Fan: external rotor helical type electric fan and permanent magnet motor (EC brushless) for electronic speed control, equipped with internal thermal protection and accident protection grilles.
- Control: microprocessor electronic control with Adaptive Function Plus logic.
- Structure: suitably sound-proofed, galvanised and painted steel plate, complete with antifreeze heater on the condensate drain pan.
- The unit is also complete with:
 - outdoor air temperature probe for set-point compensation;
 - display of cooling circuit high and low pressure;
 - clock board.

Version

T - High efficiency/temperature version.

Set ups

- PUMP P1 - Unit complete with: electric circulation pump and manual air vent valve.
- PUMP P1 V3V - Unit complete with: electric circulation pump, manual air vent valve, 3-way diverter valve for the production of domestic hot water.
- PUMP P1 DS - Unit complete with: electric circulation pump to the main heat exchanger, manual air vent valve and desuperheater complete with antifreeze heater.

Separately sold kits are COMPULSORY

- Remote keypad with back-lit LCD display, which can be wall-mounted or installed on the machine.
- Side buffer panels.

Separately sold kits are MANDATORY

- when multiple modules are installed in parallel
- Connection hoses between modules.
 - Panels and telephone cables for module connection.

Factory fitted accessories

- Forced Download. Compressor partialisation or switch-off to limit power and current consumption (digital input). When multiple modules are connected in parallel, a KCSC accessory must be purchased in order to enable this signal.
- Set up with oversized head pump.
- Soft-Start device.
- Unit with copper/pre-painted aluminium or copper/copper condensation coils.
- Flow switch and hot wire heaters protecting pump and piping down to -20°C outdoor air.
- Silenced set up (muffled compressors).
- Cooling circuit high and low pressure gauges.
- Digital input for double set-point.
- 4-20 mA analogue signal for shifting set-point.

Separately supplied accessories

- **Digital input and output** concentrator (KCSC).
- Rubber anti-vibration mounts.
- Water filter.
- Right-hand connection kit.
- 3-way diverter valve to manage the production of domestic hot water complete with protective casing and hoses for machine connection. For downstream installation of the group of machines. Not compatible with PUMP V3V set up.
- Additional electrical resistance for heat pump managed by regulation.
- Interfaces for serial communication with other devices.
- Serial converter (RS485/USB).
- Rhoss supervisors for unit monitoring and remote management.



THAETY H.T. MODEL		234			
		1 modulo	2 moduli	3 moduli	4 moduli
① Heating capacity	kW	33,8	67,6	101,4	135,2
① Absorbed power	kW	9,85	19,71	29,56	39,42
① C.O.P.		3,42	3,42	3,42	3,42
② Heating capacity	kW	23,49	46,98	70,47	93,96
② Absorbed power	kW	9,83	19,66	29,48	39,31
② C.O.P.		2,39	2,39	2,39	2,39
③ Heating capacity	kW	33,9	67,88	101,82	135,76
③ Absorbed power	kW	8,11	16,24	24,36	32,48
③ C.O.P.		4,18	4,18	4,18	4,18
④ Cooling capacity	kW	28,8	57,6	86,4	115,2
④ E.E.R.		2,93	2,93	2,93	2,93
⑤ Sound pressure	dB(A)	43	46	47	48
⑤ Silenced setup sound pressure	dB(A)	41	44	45	46
Scroll/step compressor	no.	2/2	4/4	6/6	8/8
④ Electric pump nominal available head	kPa	137	137	137	137
Electrical supply	V-ph-Hz	400-3-50	400-3-50	400-3-50	400-3-50
DIMENSIONS AND WEIGHTS		1 modulo	2 moduli	3 moduli	4 moduli
L - Width	mm	1297	2541	3785	5029
H - Height	mm	2152	2152	2152	2152
P - Depth	mm	1224	1224	1224	1224
⑥ Weight	kg	510 (relativo ad un singolo modulo)			

Data at the following conditions:

- ① Air: 7°C D.B. - 6°C W.B. - Water: 40/45°C.
- ② Air: -7°C D.B. - Water: 40/45°C.
- ③ Air: 7°C D.B. - 6°C W.B. - Water: 30/35°C.
- ④ Air: 35°C D.B. - Water: 12/7°C.
- ⑤ In open field (Q = 2) at 10 m from the unit.
- ⑥ Weight refers to P1 DS setup.

Performance according to EN 14511

SEASONAL ENERGY PERFORMANCE		234			
		1 modulo	2 moduli	3 moduli	4 moduli
THAETY H.T. MODEL SEASONAL PERFORMANCE IN HEATING MODE - Low temperature application 35°C					
③ Pdesignh (EN 14825)	kW	32	65	98	131
③ SCOP (EN 14825)		3,94	4	4,05	4,12
④ η_s	%	155	157	159	162
④ Energy class		A++	A++	-	-
THAETY H.T. MODEL SEASONAL PERFORMANCE IN HEATING MODE - Medium temperature application 55°C					
③ Pdesignh (EN 14825)	kW	33	66	99	131
③ SCOP (EN 14825)		3,09	3,14	3,21	3,28
④ η_s	%	121	123	125	128
④ Energy class		A+	A+	-	-

③ In Average climatic conditions

④ Seasonal energy efficiency: heating in Average climate (EU Regulations No.811/2013 and No.813/2013)

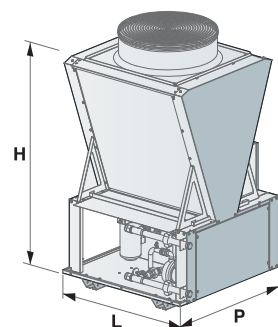

EasyPACK ECO

TCAEI-THAEI 270÷2150



Cooling capacity: 69.4-153.7 kW - Heating capacity: 75.2-152.3 kW



THAEI 2150 with coil protection
metal filters accessory

TCAEI 285 with coil protection
metal filters accessory



- Efficient and eco-friendly range in R32
- Full optional unit
- Integrated MASTER/SLAVE control
- Partial heat recovery with pump and mixing valve

Water chillers and packaged reversible air-cooled heat pumps with axial fans. Range with hermetic scroll compressors and R32 refrigerant.

Construction features

- Compressor: scroll type, rotary, hermetic complete with thermal protection and casing heater.
- 3 capacity steps with high efficiency at partial loads.
- Water side heat exchanger: with stainless steel plates, complete with closed cell polyurethane foam rubber insulation and water flow differential pressure switch.
- Air side heat exchanger: featuring micro-channels (TCAEI) or finned coil with copper pipes and aluminium fins (THAEI).
- Fan: external rotor axial type electric fans equipped with internal thermal protection, accident protection grilles and proportional electronic device for continuous fan rotation speed regulation.
- Control: microprocessor electronic control with Adaptive Function Plus logic.
- Structure: load-bearing structure made of galvanised and painted steel plate with polyester powder coating.
- The unit is also complete with:
 - compressor and fan circuit breaker switches;
 - electronic expansion valve;
 - display of cooling circuit high and low pressure;
 - Master/Slave control up to 4 units in parallel;
 - clock board;
 - control of Variable Primary Flow (VPF_R).

Versions

- T - High efficiency version with oversized condensing section (TCAEI-THAEI).
- Q - Super-silenced version complete with compressor technical compartment soundproofing, reduced speed fans and oversized condensing section (TCAEQI-THAEQI).

Models

- TCAEI: high efficiency unit designed for cooling only.
- TCAEQI: super silenced unit designed for cooling only.
- THAEI: heat pump unit.
- THAEQI: super silenced heat pump unit.

Factory fitted accessories

- PUMP with single or double electric pump, one of which automatic in standby. The electric pumps are available in the low or high head versions.
- TANK&PUMP with 230 - 440 litre integrated buffer tank (depending on the sizes) and single or double electric pump, complete with expansion tank, air vent valves, safety valve and water side pressure gauge.
- Inverter pump control for unit start-up.
- Desuperheater.
- Desuperheater with pump and mixing valve
- 100% heat recovery unit (TCAEI)
- Condensing control with fans with EC motor (fitted as standard in TCAEQI-THAEQI 270-285).
- Condensing control with over-pressure fans (T version only)
- Power factor correction capacitors ($\cos\phi > 0.94$).
- Forced limit of power consumption.
- Forced noise limit.
- Energy parameter measuring device.
- Soft starter.
- Technical compressor compartment soundproofing.
- Compressor soundproof enclosures.
- Cooling circuit outlet and inlet valves (TCAEI-TCAEQI).
- Cooling circuit outlet valves (THAEI-THAEQI).
- Refrigerant leak detector.
- Cooling circuit high and low pressure gauges.
- Double safety valves.
- Metal filters or coil protection nets.
- Microchannel coils with E-coating treatment, copper/copper, copper/aluminium, pre-painted copper/aluminium or with hydrophilic treatment depending on versions.
- Control of min/max power supply voltage and backup battery
- Digital input for double set-point.
- 4-20 mA analogue signal for shifting set-point.
- Evaporator antifreeze heater, electrical panel, buffer tank, electric pumps and heat exchangers for heat recovery, if applicable, and base.
- Low temperature water production.
- Interfaces for serial communication with other devices.
- Rubber anti-vibration mounts.

Separately supplied accessories

- Remote keypad with display.
- Thermostat with display.
- Rhoss supervisors for unit monitoring and remote management.
- Rhoss sequencer for integrated management of multiple chillers.



TCAETI-TCAEQI MODEL		270	285	2100	2110	2120	2140	2150	
①	Nominal cooling capacity	kW	74,1	88,6	101	110,5	121,7	140,8	153,7
①	Nominal cooling capacity	kW	72,5	85,8	98,5	108	119,3	137,6	149,5
①	E.E.R.		3,15	3,11	3,26	3,18	3,27	3,18	3,13
①	E.E.R.		3,04	2,95	3,14	3,06	3,15	3,06	2,97
①	Absorbed power	kW	23,5	28,5	30,98	34,75	37,22	44,28	49,11
①	Absorbed power	kW	23,85	29,08	31,37	35,29	37,87	44,97	50,34
THAETI-THAEQI MODEL		270	285	2100	2110	2120	2140	2150	
②	Nominal heating capacity	kW	76,1	89,4	100,3	109,1	123	139,4	152,3
②	Nominal heating capacity	kW	75,2	88	98,2	106,6	121,2	138,9	150,1
②	C.O.P.		3,23	3,25	3,31	3,25	3,28	3,25	3,26
②	C.O.P.		3,27	3,25	3,32	3,25	3,33	3,32	3,29
①	Nominal cooling capacity	kW	71	83,8	96,1	105,6	117	133,7	146,1
①	Nominal cooling capacity	kW	69,4	81,9	93,5	101,1	113,8	130,6	141,7
②	Absorbed power	kW	23,56	27,51	30,3	33,57	37,5	42,89	46,72
②	Absorbed power	kW	23	27,08	29,58	32,8	36,4	41,84	45,62
TCAEI-THAEI MODEL		270	285	2100	2110	2120	2140	2150	
③	TCAETI-THAETI sound pressure	dB(A)	50	52	54	54	55	56	56
③	TCAEQI-THAEQI sound pressure	dB(A)	44	46	47	47	49	50	50
④	TCAETI-THAETI sound power	dB(A)	82	84	85,5	86	87	88	88
④	TCAEQI-THAEQI sound power	dB(A)	76	78	79	79	81	82	82
	Scroll/step compressor	n.	2/3	2/3	2/3	2/3	2/3	2/3	2/3
	Circuits	n.	1	1	1	1	1	1	1
	Electrical supply	V-ph-Hz	400-3+N-50	400-3+N-50	400-3+N-50	400-3+N-50	400-3+N-50	400-3+N-50	400-3+N-50
DIMENSIONS AND WEIGHTS		270	285	2100	2110	2120	2140	2150	
	L - Width	mm	3250	3250	3250	3250	3450	3450	3450
	TCAETI-THAETI H - Height	mm	1700	1700	1800	1800	2000	2000	2000
	TCAEQI-THAEQI H - Height	mm	1540	1540	1800	1800	2000	2000	2000
	P - Depth	mm	1210	1210	1210	1210	1520	1520	1520
⑤	TCAETI weight	kg	795	825	875	880	1065	1165	1170
⑤	THAETI weight	kg	885	915	965	970	1170	1270	1275

Data at the following conditions:

- ① Air: 35°C - Water: 12/7°C
- ② Air: 7°C, D.B. - 6°C W.B. - Water: 40/45°C.
- ③ In open field (Q = 2) at 10 m from the unit.
- ④ Total sound power level in dB(A) based on measurements carried out in accordance with regulation UNI EN-ISO 9614.
- ⑤ Weight referred to the unit without load and not accessorised.

■ TCAEQI-THAEQI super-silenced versions.

Performance according to EN 14511.

SEASONAL ENERGY PERFORMANCE		270	285	2100	2110	2120	2140	2150	
TCAETI MODEL SEASONAL PERFORMANCE IN COOLING MODE									
①	P _{designc} (EN 14825)	kW	74,1	88,6	101	110,5	121,7	140,8	153,7
①	SEER (EN 14825)		4,5	4,47	4,63	4,62	4,55	4,58	4,49
②	η _{s,c}	%	177	176	182	182	179	180	177
TCAEQI MODEL SEASONAL PERFORMANCE IN COOLING MODE									
①	P _{designc} (EN 14825)	kW	72,5	85,8	98,5	108	119,3	137,6	149,5
①	SEER (EN 14825)		4,45	4,39	4,46	4,45	4,4	4,4	4,29
②	η _{s,c}	%	175	173	175	175	173	173	169
THAETI MODEL SEASONAL ENERGY PERFORMANCE IN HEATING MODE									
③	P _{designh} (EN 14825)	kW	60	71	80	87	98	112	122
③	SCOP (EN 14825)		4,07	4,11	4,11	4,12	4	4,12	4,07
④	η _s	%	160	161	161	162	157	162	160
④	Energy class		A++	-	-	-	-	-	-
THAEQI MODEL SEASONAL ENERGY PERFORMANCE IN HEATING MODE									
③	P _{designh} (EN 14825)	kW	60	70	78	85	96	111	120
③	SCOP (EN 14825)		4,13	4,19	4,09	4,03	3,99	4,08	4,04
④	η _s	%	162	164	161	158	156	160	159
④	Energy class		A++	A++	-	-	-	-	-

- ① Low temperature application (7°C)
- ② Seasonal energy efficiency: low temperature cooling (EU Regulation 2016/2281)
- ③ In Average climatic conditions, low temperature application (35°C)
- ④ Seasonal energy efficiency: low temperature heating in Average climate (EU Regulations No.811/2013 and No.813/2013)

EasyPACK-I

TCAIY-THAIY 270÷2130

Cooling capacity: 67.1-130.4 kW - Heating capacity: 71.2-134.6 kW

INVERTER



- Chillers and heat pumps with inverter compressors
- Precise and efficient power modulation
- Plug&Play unit with integrated hydronic module and heat recovery
- Integrated MASTER/SLAVE control



THAIY 2130 with coil protection metal filters accessory

TCAIY 2100 with coil protection metal filters accessory

Water chillers and packaged reversible air-cooled heat pumps with axial fans. Range with scroll hermetic compressors, DC Inverter and R410A refrigerant.

Construction features

- Compressor: scroll type, rotary, hermetic and with Inverter actuation (1+i) complete with thermal protection and casing heater.
- Continuous regulation with high efficiency at partial loads.
- Water side heat exchanger: with stainless steel plates, complete with closed cell polyurethane foam rubber insulation and water flow differential pressure switch.
- Air side heat exchanger: featuring micro-channels (TCAIY) or finned coil with copper pipes and aluminium fins (THAIY).
- Fan: external rotor axial type electric fans with internal thermal protection, accident protection grilles. The electric fans, based on the sizes, are EC fans or fitted with a proportional electronic device for continuous regulation of the rotation speed of the fans.
- Control: microprocessor electronic control with Adaptive Function Plus logic.
- Structure: load-bearing structure made of galvanised and painted steel plate with polyester powder coating.
- The unit is also complete with:
 - compressor and fan circuit breaker switches;
 - electronic expansion valve;
 - display of cooling circuit high and low pressure;
 - Master/Slave control up to 4 units in parallel;
 - clock board;
 - control of Variable Primary Flow (VPF_R).

Versions

- T - High efficiency version with oversized condensing section (TCAIY-THAIY).
- Q - Super-silenced version complete with compressor technical compartment soundproofing, reduced speed fans and oversized condensing section (TCAIQY-THAIQY).

Models

- TCAIY: high efficiency unit designed for cooling only.
- TCAIQY: super silenced unit designed for cooling only.
- THAIY: heat pump unit.
- THAIQY: super silenced heat pump unit.

Factory fitted accessories

- PUMP with single or double electric pump, one of which automatic in standby. The electric pumps are available in the low or high head versions.
- TANK&PUMP with 230 - 440 litre integrated buffer tank (depending on the sizes) and single or double electric pump, complete with expansion tank, air vent valves, safety valve and water side pressure gauge.
- Inverter pump control for unit start-up.
- Desuperheater.
- 100% heat recovery unit
- Condensing control with fans with EC motor (standard in sizes 270-2100).
- Condensing control with over-pressure fans (T version only)
- Power factor correction capacitors ($\cos\phi > 0.94$).
- Forced limit of power consumption.
- Forced noise limit.
- Energy parameter measuring device.
- Optimised energy efficiency.
- Soft starter.
- Technical compressor compartment soundproofing.
- Compressor soundproof enclosures.
- Cooling circuit outlet and inlet valves.
- Refrigerant leak detector.
- Cooling circuit high and low pressure gauges.
- Double safety valves.
- Metal filters or coil protection nets.
- Microchannel coils with E-coating treatment, copper/copper, copper/aluminium or pre-painted copper/aluminium depending on the versions.
- Control of min/max power supply voltage.
- Digital input for double set-point.
- 4-20 mA analogue signal for shifting set-point.
- Evaporator antifreeze heater, electrical panel, buffer tank, electric pumps and heat exchangers for heat recovery, if applicable.
- Interfaces for serial communication with other devices.
- Rubber anti-vibration mounts.

Separately supplied accessories

- Remote keypad with display.
- Thermostat with display.
- Rhoss supervisors for unit monitoring and remote management.
- Rhoss sequencer for integrated management of multiple chillers.



TCAITY-TCAIQY MODEL		270	280	290	2100	2115	2130	
①	Nominal cooling capacity	kW	69,8	82,6	90,3	97,9	130,4	
①	Nominal cooling capacity	kW	67,8	80,8	87,7	93,4	125,5	
①	E.E.R.		3,16	3,17	3,15	3,02	3,14	
①	E.E.R.		3,01	3,06	3	2,84	3,01	
①	Absorbed power	kW	22,09	26,06	28,67	32,42	41,53	
①	Absorbed power	kW	22,52	26,41	29,23	32,89	41,69	
THAIY-THAIQY MODEL		270	280	290	2100	2115	2130	
②	Nominal heating capacity	kW	73,4	85,4	92,5	100,6	134,6	
②	Nominal heating capacity	kW	71,2	83,4	90,4	98,7	130,6	
②	C.O.P.		3,37	3,34	3,36	3,34	3,32	
②	C.O.P.		3,31	3,33	3,32	3,3	3,36	
①	Nominal cooling capacity	kW	67,1	79,3	86,8	93,5	126,5	
①	Nominal cooling capacity	kW	65	77,9	84,7	90,3	123,5	
②	Absorbed power	kW	21,78	25,57	27,53	30,12	40,54	
②	Absorbed power	kW	21,51	25,05	27,23	29,91	38,87	
TCAIY-THAIY MODEL		270	280	290	2100	2115	2130	
③	TCAITY-THAIY sound pressure	dB(A)	52	53	53	55	56	
③	TCAIQY-THAIQY sound pressure	dB(A)	45	46	46	49	50	
④	TCAITY-THAIY sound power	dB(A)	84	85	85	85	88	
④	TCAIQY-THAIQY sound power	dB(A)	77	77,5	77,5	77,5	82	
	Scroll/step compressor	n.	1+i / regolazione continua					
	Circuits	n.	1	1	1	1	2	
	Electrical supply	V-ph-Hz	400-3+N-50	400-3+N-50	400-3+N-50	400-3+N-50	400-3+N-50	
DIMENSIONS AND WEIGHTS		270	280	290	2100	2115	2130	
	L - Width	mm	3250	3250	3250	3450	3450	
	H - Height	mm	1540	1540	1540	2000	2000	
	P - Depth	mm	1210	1210	1210	1520	1520	
⑤	TCAITY weight	kg	765	790	795	800	1145	
⑤	THAIY weight	kg	880	915	920	925	1345	

Data at the following conditions:

- ① Air: 35°C - Water: 12/7°C
 - ② Air: 7°C, D.B. - 6°C W.B. - Water: 40/45°C.
 - ③ In open field (Q = 2) at 10 m from the unit.
 - ④ Total sound power level in dB(A) based on measurements carried out in accordance with regulation UNI EN-ISO 9614.
 - ⑤ Weight referred to the unit without load and not accessorised.
- TCAIQY-THAIQY super-silenced versions.
Performance according to EN 14511.

SEASONAL ENERGY PERFORMANCE		270	280	290	2100	2115	2130
TCAITY MODEL SEASONAL PERFORMANCE IN COOLING MODE							
①	P _{designc} (EN 14825)	kW	69,8	82,6	90,3	97,9	130,4
①	SEER (EN 14825)		4,59	4,69	4,65	4,6	4,27
②	η _{s,c}	%	181	184	183	181	168
TCAIQY MODEL SEASONAL PERFORMANCE IN COOLING MODE							
①	P _{designc} (EN 14825)	kW	67,8	80,8	87,7	93,4	125,5
①	SEER (EN 14825)		4,49	4,58	4,49	4,45	4,11
②	η _{s,c}	%	176	180	177	175	161
THAIY MODEL SEASONAL ENERGY PERFORMANCE IN HEATING MODE							
③	P _{designh} (EN 14825)	kW	71	80	87	95	126
③	SCOP (EN 14825)		4,09	4,19	4,17	4,15	3,99
④	η _s	%	161	164	164	163	156
④	Energy class		-	-	-	-	-
THAIQY MODEL SEASONAL ENERGY PERFORMANCE IN HEATING MODE							
③	P _{designh} (EN 14825)	kW	67	78	85	93	133
③	SCOP (EN 14825)		3,99	4,1	4,05	4,06	3,88
④	η _s	%	157	161	159	160	155
④	Energy class		A++	-	-	-	-

- ① Low temperature application (7°C)
- ② Seasonal energy efficiency: low temperature cooling (EU Regulation 2016/2281)
- ③ In Average climatic conditions, low temperature application (35°C)
- ④ Seasonal energy efficiency: low temperature heating in Average climate (EU Regulations No.811/2013 and No.813/2013)

EasyPACK

TCAEY-THAEY 269÷2146

Cooling capacity: 63.7-144.4 kW - Heating capacity: 70.3-151.7 kW



TCAEY 289 with coil protection
metal filters accessory



- **Complete and flexible range of accessories and set-ups**
- **Multi-purpose for systems with 2 pipes+DHW (with optional RC100)**
- **Integrated MASTER/SLAVE control**
- **HT65 version for 65°C water production (°)**

Water chillers and packaged reversible air-cooled heat pumps with axial fans.
Range with scroll hermetic compressors and R410A refrigerant.

Construction features

- Compressor: scroll type, rotary, hermetic complete with thermal protection and casing heater.
- 3 capacity steps with high efficiency at partial loads.
- Water side heat exchanger: with stainless steel plates, complete with closed cell polyurethane foam rubber insulation and water flow differential pressure switch.
- Air side heat exchanger: featuring micro-channels or finned coil with copper pipes and aluminium fins depending on models/sizes.
- Fan: external rotor axial type electric fans equipped with internal thermal protection and accident protection grilles. The electric fans, based on the versions, are fitted with a proportional electronic device for continuous regulation of the rotation speed of the fans.
- Control: microprocessor electronic control with Adaptive Function Plus logic.
- Structure: load-bearing structure made of galvanised and painted steel plate with polyester powder coating.
- The unit is also complete with:
 - fan and compressor circuit breaker switches;
 - display of cooling circuit high and low pressure;
 - Master/Slave control up to 4 units in parallel;
 - clock board;
 - control of Variable Primary Flow (VPF_R).

Versions

- B - Standard version (TCAEY).
- T - High efficiency version with oversized condensing section (TCAEY-THAEY).
- S - Silenced version complete with compressor compartment soundproofing, reduced speed fans, and oversized condensing section (TCAESY-THAESY).
- Q - Super-silenced version complete with compressor technical compartment soundproofing, super-reduced speed fans and oversized condensing section (TCAEQY-THAEQY).

Models

- TCAEY: standard unit designed for cooling only.
- TCAEY: high efficiency unit designed for cooling only.
- TCAESY: silenced unit designed for cooling only.
- TCAEQY: super silenced unit designed for cooling only.
- THAEY: heat pump unit.
- THAESY: silenced heat pump unit.
- THAEQY: super silenced heat pump unit.

Factory fitted accessories

- Shell and tube evaporator.
- PUMP with single or double electric pump, one of which automatic in standby. The electric pumps are available in the low or high head versions.
- TANK&PUMP with 230 to 440 litre integrated buffer tank (depending on models) and single or double electric pump, complete with expansion tank, air vent valves, safety valve, and water side pressure gauge.
- Inverter pump control for unit start-up.
- Desuperheater.
- 100% heat recovery unit
- Electronic expansion valve.
- Condensing control (standard in B-S-Q versions).
- Condensing control with fans with EC motor.
- Condensing control with over-pressure fans (B-T version only)
- Power factor correction capacitors ($\cos\phi > 0.94$).
- Forced limit of power consumption.
- Forced noise limit.
- Energy parameter measuring device.
- Optimised energy efficiency.
- Soft starter.
- Technical compartment soundproofing.
- Compressor soundproof enclosures.
- Cooling circuit outlet and inlet valves.
- Refrigerant leak detector.
- Cooling circuit high and low pressure gauges.
- Double safety valves.
- Metal filters or coil protection nets.
- Microchannel coils with E-coating treatment, copper/copper or pre-painted copper/aluminium depending on the versions.
- Control of min/max power supply voltage.
- Digital input for double set-point.
- 4-20 mA analogue signal for shifting set-point.

(°) Refer to the specific documentation to check available models and accessories.



TCAEBY 269

- Evaporator antifreeze heater, electrical panel, buffer tank, electric pumps and heat exchangers for heat recovery, if applicable.
- Buffer tank integrative heaters.
- Low temperature water production.
- Interfaces for serial communication with other devices.
- Rubber anti-vibration mounts.

Separately supplied accessories

- Remote keypad with display.
- Thermostat with display.
- Rhoss supervisors for unit monitoring and remote management.
- Rhoss sequencer for integrated management of multiple chillers.

TCAEY MODEL		269	279	289	296	2112	2125	2146
❶	Nominal cooling capacity	kW	65,6	72,1	77,6	86,5	105,5	-
❶	E.E.R.		2,74	2,81	2,81	2,62	2,79	-
❶	Absorbed power	kW	23,94	25,66	27,62	33,02	37,81	-
TCAEY-TCAESY-TCAEQY MODEL		269	279	289	296	2112	2125	2146
❶	Nominal cooling capacity	kW	69,2	79,1	90,1	96,1	112	125,5
❶	Nominal cooling capacity	kW	67,7	76,7	87,6	92,1	108	122
❶	Nominal cooling capacity	kW	64,7	71,2	84,6	89,6	101,1	116,5
❶	E.E.R.		3,12	3,18	3,12	3,11	3,1	3,12
❶	E.E.R.		2,92	3,05	2,95	2,92	2,94	2,99
❶	E.E.R.		2,82	2,72	2,8	2,72	2,53	2,72
❶	Absorbed power	kW	22,18	24,87	28,88	30,9	36,13	40,22
❶	Absorbed power	kW	23,18	25,15	29,69	31,54	36,73	40,8
❶	Absorbed power	kW	22,94	26,18	30,21	32,94	39,96	42,83
THAEY-THAESY-THAEQY MODEL		269	279	289	296	2112	2125	2146
❷	Nominal heating capacity	kW	73,4	82,4	92,4	100,5	118,5	133,1
❷	Nominal heating capacity	kW	70,8	80,4	90,4	98	115	129,1
❷	Nominal heating capacity	kW	70,3	77,3	88,4	95,4	111	125,5
❷	C.O.P.		3,35	3,36	3,31	3,28	3,31	3,25
❷	C.O.P.		3,32	3,36	3,31	3,29	3,3	3,27
❷	C.O.P.		3,31	3,3	3,27	3,26	3,21	3,23
❶	Nominal cooling capacity	kW	67,2	76,7	86,6	93,6	107,5	121,5
❶	Nominal cooling capacity	kW	66,2	74,7	85,7	89,6	104,6	119
❶	Nominal cooling capacity	kW	63,7	69,7	82,7	86,6	99,1	112,1
❷	Absorbed power	kW	21,91	24,52	27,92	30,64	35,8	40,95
❷	Absorbed power	kW	21,33	23,93	27,31	29,79	34,85	39,48
❷	Absorbed power	kW	21,24	23,42	27,03	29,26	34,58	38,85
TCAEY-THAEY MODEL		269	279	289	296	2112	2125	2146
❸	TCAEY sound pressure	dB(A)	50	50	50	50	52	-
❸	TCAEY-THAEY sound pressure	dB(A)	50	51	51	51	53	54
❸	TCAESY-THAESY sound pressure	dB(A)	46	47	47	47	49	50
❸	TCAEQY-THAEQY sound pressure	dB(A)	42	42	43	43	46	47
❹	TCAEY sound power	dB(A)	82	82	82	82	84	-
❹	TCAEY-THAEY sound power	dB(A)	82	83	83	83	85	86
❹	TCAESY-THAESY sound power	dB(A)	78	79	79	79	81	82
❹	TCAEQY-THAEQY sound power	dB(A)	74	74	75	75	78	79
	Scroll/step compressor	n.	2/3	2/3	2/3	2/3	2/3	2/3
	Circuits	n.	1	1	1	1	1	1
	Electrical supply	V-ph-Hz	400-3+N-50	400-3+N-50	400-3+N-50	400-3+N-50	400-3+N-50	400-3+N-50
DIMENSIONS AND WEIGHT		269	279	289	296	2112	2125	2146
	W - Width of version B	mm	2650	2650	2650	3250	-	-
	W - Width of version T - S - Q	mm	3250	3250	3250	3250	3450	3450
	H - Height of version B	mm	1700	1700	1700	1700	-	-
	H - Height of version T - S	mm	1700	1700	1700	1700	2000	2000
	H - Height of version Q	mm	1520	1520	1520	1520	2000	2000
	D - Depth of version B	mm	1210	1210	1210	1210	-	-
	D - Depth of version T - S - Q	mm	1210	1210	1210	1210	1520	1520
❺	TCAEY weight	kg	755	760	795	800	980	-
❺	TCAEY weight	kg	850	865	870	905	1195	1255
❺	THAEY weight	kg	915	930	935	980	1280	1355

Data at the following conditions:

- ❶ Air: 35°C - Water: 12/7°C
- ❷ Air: 7°C, D.B. - 6°C W.B. - Water: 40/45°C.
- ❸ In open field (Q = 2) at 10 m from the unit.
- ❹ Total sound power level in dB(A) based on measurements carried out in accordance with regulation UNI EN-ISO 9614.
- ❺ Weight referred to the unit without load and not accessorised.

■ TCAESY-THAESY silenced versions.

■ TCAEQY-THAEQY super-silenced versions.

Performance according to EN 14511.

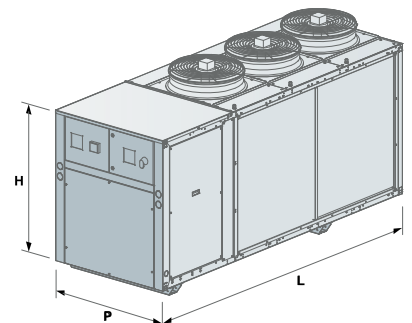

SEASONAL ENERGY PERFORMANCE		269	279	289	296	2112	2125	2146
TCAEBY MODEL SEASONAL PERFORMANCE IN COOLING MODE								
①	P _{designc} (EN 14825)	kW	65,6	72,1	77,6	86,5	105,5	-
①	SEER (EN 14825)		4,35	4,19	4,2	4,14	4,34	-
②	$\eta_{s,c}$	%	171	164	165	163	170	-
TCAETY MODEL SEASONAL PERFORMANCE IN COOLING MODE								
①	P _{designc} (EN 14825)	kW	69,2	79,1	90,1	96,1	112	125,5
①	SEER (EN 14825)		4,43	4,35	4,45	4,48	4,46	4,41
②	$\eta_{s,c}$	%	174	171	175	176	175	173
TCAESY MODEL SEASONAL PERFORMANCE IN COOLING MODE								
①	P _{designc} (EN 14825)	kW	67,7	76,7	87,6	92,1	108	122
①	SEER (EN 14825)		4,34	4,35	4,35	4,37	4,4	4,42
②	$\eta_{s,c}$	%	170	171	171	172	173	174
TCAEQY MODEL SEASONAL PERFORMANCE IN COOLING MODE								
①	P _{designc} (EN 14825)	kW	64,7	71,2	84,6	89,6	101,1	116,5
①	SEER (EN 14825)		4,27	4,17	4,3	4,23	4,16	4,17
②	$\eta_{s,c}$	%	168	164	169	166	163	164
THAETY MODEL SEASONAL ENERGY PERFORMANCE IN HEATING MODE								
③	P _{designh} (EN 14825)	kW	66	74	84	91	108	121
③	SCOP (EN 14825)		3,99	3,97	3,91	3,9	4,03	3,9
④	η_s	%	157	156	153	153	158	153
④	Energy class		A++	-	-	-	-	-
THAESY MODEL SEASONAL ENERGY PERFORMANCE IN HEATING MODE								
③	P _{designh} (EN 14825)	kW	64	73	82	89	104	117
③	SCOP (EN 14825)		3,98	4	3,92	3,93	4,02	3,96
④	η_s	%	156	157	154	154	158	155
④	Energy class		A++	-	-	-	-	-
THAEQY MODEL SEASONAL ENERGY PERFORMANCE IN HEATING MODE								
③	P _{designh} (EN 14825)	kW	64	70	80	86	100	114
③	SCOP (EN 14825)		3,98	3,97	3,92	3,92	3,93	3,92
④	η_s	%	156	156	154	154	154	154
④	Energy class		A++	A++	-	-	-	-

- ① Low temperature application (7°C)
- ② Seasonal energy efficiency: low temperature cooling (EU Regulation 2016/2281)
- ③ In Average climatic conditions, low temperature application (35°C)
- ④ Seasonal energy efficiency: low temperature heating in Average climate (EU Regulations No.811/2013 and No.813/2013)

WinPACK HE-A

TCAEY-THAEY 2110÷4340

Cooling capacity: 91.6-345 kW - Heating capacity: 110.5-357 kW



THAEY 4270 with coil protection nets accessory

- High energy efficiency chillers and heat pumps
- Standard electronic expansion valve
- Multi-purpose for systems with 2 pipes + DHW (with optional RC100)
- Built-in MASTER/SLAVE control

Water chillers and packaged reversible air-cooled heat pumps with axial fans. Range with scroll hermetic compressors and R410A refrigerant.

Construction features

- Compressor: scroll type, rotary, hermetic complete with thermal protection and casing heater.
 - 2, 3 or 4 capacity steps with high efficiency at partial loads.
- Water side heat exchanger: with stainless steel plates, complete with closed cell polyurethane foam rubber insulation and water flow differential pressure switch.
- Air side heat exchanger: featuring micro-channels or finned coil with copper pipes and aluminium fins depending on models/sizes.
 - Fan: external rotor axial type electric fans with internal thermal protection, accident protection grilles.
 - Control: microprocessor electronic control with Adaptive Function Plus logic.
 - Structure: load-bearing structure made of galvanised and painted steel plate with polyester powder coating.
 - The unit is also complete with:
 - fan and compressor circuit breaker switches;
 - display of cooling circuit high and low pressure;
 - electronic expansion valve;
 - Master/Slave control up to 4 units in parallel;
 - clock board;
 - control of Variable Primary Flow (VPF_R).

Versions

- T - High efficiency version with oversized condensing section (TCAEY-THAEY).
- Q - Super-silenced version complete with soundproofing compressor technical compartment, super-reduced speed fans and oversized condensing section (TCAEQY-THAEQY).

Models

- TCAEY: high efficiency unit designed for cooling only.
- TCAEQY: super silenced unit designed for cooling only.
- THAEY: heat pump unit.
- THAEQY: super silenced heat pump unit.

Factory fitted accessories

- Shell and tube evaporator.
- PUMP with single or double electric pump, one of which automatic in standby. The electric pumps are available in the low or high head versions.
- TANK&PUMP with integrated buffer tank from 300 to 700 litres (depending on models) and single or double electric pump, complete with expansion tank, air vent valves, safety valve, and water side pressure gauge.
- Inverter pump control for unit start-up.
- Desuperheater.
- 100% heat recovery unit.
- Condensing control.
- Condensing control with fans with EC motor (standard in Q versions).
- Condensing control with over-pressure fans.
- Power factor correction capacitors ($\cos\phi > 0.94$).
- Forced limit of power consumption.
- Forced noise limit.
- Energy parameter measuring device.
- Optimised energy efficiency.
- Soft starter.
- Soundproofed compressor box or technical compartment soundproofing.
- Compressor soundproof enclosures.
- Cooling circuit outlet and inlet valves.
- Refrigerant leak detector.
- Cooling circuit high and low pressure gauges.
- Double safety valves.
- Metal filters or coil protection nets.
- Microchannel coils with E-coating treatment, copper/



TCAEQY 2150
with Tank&Pump

copper or pre-painted copper/aluminium depending on the versions.

- Control of min/max power supply voltage.
- Digital input for double set-point.
- 4-20 mA analogue signal for shifting set-point.
- Evaporator antifreeze heater, electrical panel, buffer tank, electric pumps and heat exchangers for heat recovery, if applicable.
- Buffer tank integrative heaters.
- Low temperature water production.
- Interfaces for serial communication with other devices.
- Anti-vibration mounts.

Separately supplied accessories

- Remote keypad with display.
- Thermostat with display.
- Rhoss supervisors for unit monitoring and remote management.
- Rhoss sequencer for integrated management of multiple chillers.

WinPACK HE-A

TCAEY-THAEY 2110÷4340

TCAEY-TCAEQY MODEL		2110	2120	2140	2150	2170	2200	2220	4240	4270	4310	4340	
❶	Nominal cooling capacity	kW	110,5	121,5	138,4	156,4	175,4	200,3	223,2	241,3	276,3	309,1	345,1
❶	Nominal cooling capacity	kW	100,6	108,6	126,5	140,5	155,5	181,4	199,4	218,4	251,4	280,2	318,2
❶	E.E.R.		3,13	3,1	3,13	3,11	3,1	3,11	3,1	3,1	3,1	3,1	3,1
❶	E.E.R.		2,73	2,6	2,69	2,65	2,6	2,64	2,61	2,56	2,68	2,62	2,63
❶	Absorbed power	kW	35,3	39,2	44,2	50,3	56,6	64,4	72	77,8	88,8	99,7	111,3
❶	Absorbed power	kW	36,8	41,8	47	53	59,8	68,7	76,4	85	93,8	106,9	121
THAEY-THAEQY MODEL		2110	2120	2140	2150	2170	2200	2220	4240	4270	4310	4340	
❷	Nominal heating capacity	kW	114,5	124,5	141,6	161,6	181,7	204,8	233,9	249,8	282,8	321	357
❷	Nominal heating capacity	kW	110,5	118,5	136,5	153,6	171,6	194,7	221,8	236,7	266,7	301	341,9
❷	C.O.P.		3,22	3,22	3,21	3,22	3,23	3,22	3,21	3,2	3,2	3,2	3,2
❷	C.O.P.		3,28	3,29	3,27	3,26	3,26	3,23	3,26	3,12	3,11	2,95	3,08
❶	Nominal cooling capacity	kW	101,6	112,6	126,5	145,4	161,4	186,3	209,3	231,3	263,3	301,1	334,1
❶	Nominal cooling capacity	kW	91,6	100,6	118,6	130,6	144,5	169,5	187,4	206,5	238,4	270,3	302,3
❷	Absorbed power	kW	35,6	38,7	44,1	50,2	56,3	63,6	72,9	78,1	88,4	100,3	111,6
❷	Absorbed power	kW	33,7	36	41,7	47,1	52,6	60,3	68	75,9	85,8	102	111
TCAEY-TCAEQY-THAEY-THAEQY MODEL		2110	2120	2140	2150	2170	2200	2220	4240	4270	4310	4340	
❸	TCAEY sound pressure	dB(A)	55	56	57	57	58	59	59	58	60	60	62
❸	THAEY sound pressure	dB(A)	53	54	55	55	56	57	57	58	60	60	62
❸	TCAEQY-THAEQY sound pressure	dB(A)	47	47	48	48	49	50	50	51	53	53	54
❹	TCAEY sound power	dB(A)	87	88	89	89	90	91	91	90	92	92	94
❹	THAEY sound power	dB(A)	85	86	87	87	88	89	89	90	92	92	94
❹	TCAEQY-THAEQY sound power	dB(A)	79	79	80	80	81	82	82	83	85	85	86
	Scroll/step compressor	n.	2/3	2/3	2/2	2/3	2/2	2/3	2/2	4/4	4/4	4/4	4/4
	Circuits	n.	1	1	1	1	1	1	1	2	2	2	2
	Electrical supply	V-ph-Hz	400-3-50	400-3-50	400-3-50	400-3-50	400-3-50	400-3-50	400-3-50	400-3-50	400-3-50	400-3-50	400-3-50
DIMENSIONS AND WEIGHTS		2110	2120	2140	2150	2170	2200	2220	4240	4270	4310	4340	
	L - Width	mm	3600	3600	3600	3600	4550	4550	4550	4800	4800	5300	5300
	H - Height	mm	2440	2440	2440	2440	2440	2440	2440	2030	2030	2030	2030
	P - Depth	mm	1350	1350	1350	1350	1350	1350	1350	2090	2090	2090	2090
❺	TCAEY weight	kg	1090	1100	1110	1130	1280	1300	1320	2290	2390	2520	2640
❺	TCAEQY weight	kg	1250	1260	1270	1290	1440	1460	1480	2420	2520	2650	2770
❺	THAEY weight	kg	1380	1410	1420	1500	1670	1690	1780	2470	2570	2720	2840
❺	THAEQY weight	kg	1420	1450	1460	1540	1710	1730	1820	2600	2700	2850	2970

Data at the following conditions:

- ❶ Air: 35°C - Water: 12/7°C.
- ❷ Air: 7°C, D.B. 6°C W.B. - Water: 40/45°C.
- ❸ In open field (Q = 2) at 10 m from the unit.
- ❹ Total sound power level in dB(A) based on measurements carried out in accordance with regulation UNI EN-ISO 9614.
- ❺ Weight referred to the unit without load and not accessorised.

■ TCAEQY-THAEQY super-silenced versions.

Performance according to EN 14511.

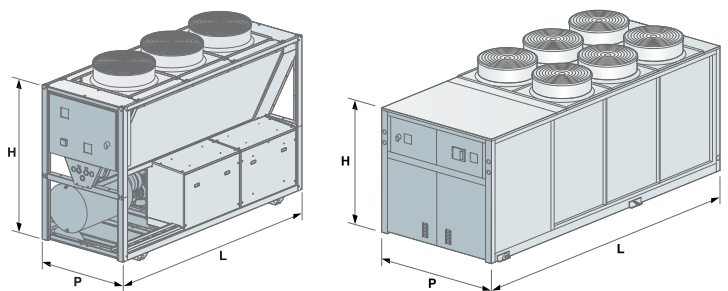

SEASONAL ENERGY PERFORMANCE		2110	2120	2140	2150	2170	2200	2220	4240	4270	4310	4340	
TCAEQY MODEL SEASONAL PERFORMANCE IN COOLING MODE													
①	P _{designc} (EN 14825)	kW	110,5	121,5	138,4	156,4	175,4	200,3	223,2	241,3	276,2	309,1	345
①	SEER (EN 14825)		4,36	4,39	4,21	4,35	4,38	4,34	4,34	4,4	4,4	4,4	4,38
②	$\eta_{s,c}$	%	171	173	165	171	172	170	171	173	173	173	172
TCAEQY MODEL SEASONAL PERFORMANCE IN COOLING MODE													
①	P _{designc} (EN 14825)	kW	100,6	108,6	126,5	140,5	155,5	181,4	199,4	218,4	251,4	280,2	318,2
①	SEER (EN 14825)		4,3	4,13	4,15	4,23	4,12	4,24	4,13	4,21	4,3	4,31	4,26
②	$\eta_{s,c}$	%	169	162	163	166	162	167	162	166	169	170	167
THAETY MODEL SEASONAL PERFORMANCE IN HEATING MODE													
③	P _{designh} (EN 14825)	kW	96	104	118	135	150	173	201	211	242	273	302
③	SCOP (EN 14825)		3,53	3,51	3,75	3,49	3,76	3,39	3,57	3,64	3,62	3,64	3,63
④	η_s	%	138	138	147	137	148	133	140	142	142	143	142
THAEQY MODEL SEASONAL PERFORMANCE IN HEATING MODE													
③	P _{designh} (EN 14825)	kW	91	98	113	127	141	165	190	199	227	254	288
③	SCOP (EN 14825)		3,62	3,61	3,84	3,59	3,88	3,53	3,65	3,56	3,54	3,37	3,52
④	η_s	%	142	141	151	141	152	138	143	139	139	132	138

① Low temperature application (7°C)

② Seasonal energy efficiency: low temperature cooling (EU Regulation 2016/2281)

③ In Average climatic conditions, low temperature application (35°C)

④ Seasonal energy efficiency: low temperature heating in Average climate (EU Regulations No.811/2013 and No.813/2013)

WinPACK SE

TCAEY-THAEY 2110÷4340

Cooling capacity: 97.6-328.6 kW - Heating capacity: 109.5-354.6 kW

TCAESY 2200
with Tank&Pump

- High performance range with extended working limits
- Wide range of accessories
- Compact version B for replacement markets
- Multi-purpose for systems with 2 pipes + DHW (with optional RC100)
- Built-in MASTER/SLAVE control

Water chillers and packaged reversible air-cooled heat pumps with axial fans. Range with scroll hermetic compressors and R410A refrigerant.

Construction features

- Compressor: scroll type, rotary, hermetic complete with thermal protection and casing heater.
- 2, 3 or 4 capacity steps with high efficiency at partial loads.

Water side heat exchanger: with stainless steel plates, complete with closed cell polyurethane foam rubber insulation and water flow differential pressure switch.

- Air side heat exchanger: featuring micro-channels or finned coil with copper pipes and aluminium fins depending on models/sizes.
- Fan: external rotor axial type electric fans with internal thermal protection, accident protection grilles. The electric fans, based on the models, are fitted with a proportional electronic device for continuous regulation of the rotation speed of the fans.
- Control: microprocessor electronic control with Adaptive Function Plus logic.
- Structure: load-bearing structure made of galvanised and painted steel plate with polyester powder coating.
- The unit is also complete with:
 - fan and compressor circuit breaker switches;
 - display of cooling circuit high and low pressure;
 - Master/Slave control up to 4 units in parallel;
 - clock board;
 - control of Variable Primary Flow (VPF_R).

Versions

- B - Standard version (TCAEY-THAEY).
- S - Silenced version complete with compressor technical compartment soundproofing, reduced speed fans (TCAESY-THAEY).

Models

- TCAEY: standard unit designed for cooling only.
- TCAESY: silenced unit designed for cooling only.
- THAEY: heat pump unit.
- THAESY: silenced heat pump unit

Factory fitted accessories

- Shell and tube evaporator.
- PUMP with single or double electric pump, one of which automatic in standby. The electric pumps are available in the low or high head versions.
- TANK&PUMP with integrated buffer tank from 300 to 700 litres (depending on models) and single or double electric pump, complete with expansion tank, air vent valves, safety valve, and water side pressure gauge.
- Inverter pump control for unit start-up.
- Desuperheater.
- 100% heat recovery unit.
- Electronic expansion valve.
- Condensing control (standard in models TCAEY, TCAESY, THAEY).
- Condensing control with fans with EC motor.
- Condensing control with over-pressure fans.
- Power factor correction capacitors ($\cos\phi > 0.94$).
- Forced limit of power consumption.
- Forced noise limit.
- Energy parameter measuring device.
- Optimised energy efficiency.
- Soft starter.
- Soundproofed compressor box or technical compartment soundproofing.
- Compressor soundproof enclosures.
- Cooling circuit outlet and inlet valves.
- Refrigerant leak detector.
- Cooling circuit high and low pressure gauges.
- Double safety valves.



THAEBY 4310 with coil
protection nets accessory

- Metal filters or coil protection nets.
- Microchannel coils with E-coating treatment, copper/copper and pre-painted copper/aluminium depending on the versions.
- Control of min/max power supply voltage.
- Digital input for double set-point.
- 4-20 mA analogue signal for shifting set-point.
- Evaporator antifreeze heater, electrical panel, buffer tank, electric pumps and heat exchangers for heat recovery, if applicable.
- Buffer tank integrative heaters.
- Low temperature water production.
- Interfaces for serial communication with other devices.
- Anti-vibration mounts.

Separately supplied accessories

- Remote keypad with display.
- Thermostat with display.
- Rhoss supervisors for unit monitoring and remote management.
- Rhoss sequencer for integrated management of multiple chillers.

WinPACK SE

TCAEY-THAEY 2110÷4340

TCAEY-TCAESY MODEL		2110	2120	2140	2150	2170	2200	2220
❶	Nominal cooling capacity	kW	106,5	114,4	127,4	147,3	165,2	212,1
❶	Nominal cooling capacity	kW	102,5	110,4	122,4	142,3	159,2	205,1
❶	E.E.R.		2,81	2,79	2,8	2,81	2,81	2,8
❶	E.E.R.		2,72	2,67	2,65	2,71	2,7	2,7
❶	Absorbed power	kW	37,9	41	45,5	52,4	58,8	75,8
❶	Absorbed power	kW	37,7	41,3	46,2	52,5	59	76
THAEY-THAESY MODEL		2110	2120	2140	2150	2170	2200	2220
❷	Nominal heating capacity	kW	112,6	123,7	139,7	158,8	176,9	229,1
❷	Nominal heating capacity	kW	109,5	121,7	135,7	155,8	173,9	226
❷	C.O.P.		3,05	3,08	3,08	3,04	3,06	3,07
❷	C.O.P.		3,1	3,13	3,1	3,13	3,1	3,13
❶	Nominal cooling capacity	kW	99,5	110,4	123,4	142,3	159,3	206,1
❶	Nominal cooling capacity	kW	97,6	106,5	117,5	136,4	152,3	199,2
❷	Absorbed power	kW	36,9	40,2	45,4	52,2	57,8	74,6
❷	Absorbed power	kW	35,3	38,9	43,8	49,8	56,1	72,2
TCAEY-TCAESY-THAEY-THAESY MODEL		2110	2120	2140	2150	2170	2200	2220
❸	TCAEY sound pressure	dB(A)	55	56	56	57	58	59
❸	THAEY sound pressure	dB(A)	53	54	54	55	56	57
❸	TCAESY sound pressure	dB(A)	49	50	50	51	52	53
❸	THAESY sound pressure	dB(A)	49	50	50	51	52	53
❹	TCAEY sound power	dB(A)	87	88	88	89	90	91
❹	THAEY sound power	dB(A)	85	86	86	87	88	89
❹	TCAESY sound power	dB(A)	81	82	82	83	84	85
❹	THAESY sound power	dB(A)	81	82	82	83	84	85
	Scroll/step compressor	n.	2/3	2/3	2/2	2/3	2/2	2/2
	Circuits	n.	1	1	1	1	1	1
	Electrical supply	V-ph-Hz	400-3-50	400-3-50	400-3-50	400-3-50	400-3-50	400-3-50
DIMENSIONS AND WEIGHT		2110	2120	2140	2150	2170	2200	2220
	W - TCAEY-TCAESY width	mm	2650	2650	2650	3600	3600	4550
	W - THAEY-THAESY width	mm	2650	2650	2650	3600	3600	4550
	H - TCAEY-TCAESY height	mm	2440	2440	2440	2440	2440	2440
	H - THAEY-THAESY height	mm	2440	2440	2440	2440	2440	2440
	D - TCAEY-TCAESY depth	mm	1350	1350	1350	1350	1350	1350
	D - THAEY-THAESY depth	mm	1350	1350	1350	1350	1350	1350
❺	TCAEY weight	kg	990	1000	1010	1160	1180	1340
❺	TCAESY weight	kg	1110	1120	1130	1280	1300	1460
❺	THAEY weight	kg	1250	1310	1320	1470	1480	1730
❺	THAESY weight	kg	1250	1310	1320	1470	1480	1730

Data at the following conditions:

- ❶ Air: 35°C - Water: 12/7°C.
- ❷ Air: 7°C, D.B. 6°C W.B. - Water: 40/45°C.
- ❸ In open field (Q = 2) at 10 m from the unit.
- ❹ Total sound power level in dB(A) based on measurements carried out in accordance with regulation UNI EN-ISO 9614.
- ❺ Weight referred to the unit without load and not accessorised.

■ TCAESY-THAESY silenced versions.

Performance according to EN 14511.

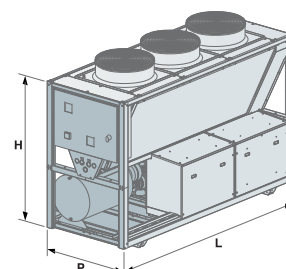

SEASONAL ENERGY PERFORMANCE		2110	2120	2140	2150	2170	2200	2220	
TCAEBY MODEL SEASONAL PERFORMANCE IN COOLING MODE									
①	P _{designc} (EN 14825)	kW	106,5	114,4	127,4	147,3	165,2	188,1	212,1
①	SEER (EN 14825)		4,16	4,15	4,13	4,17	4,14	4,27	4,13
②	$\eta_{s,c}$	%	164	163	162	164	163	168	162
TCAESY MODEL SEASONAL PERFORMANCE IN COOLING MODE									
①	P _{designc} (EN 14825)	kW	102,5	110,4	122,4	142,3	159,2	183,2	205,1
①	SEER (EN 14825)		4,19	4,18	4,11	4,23	4,15	4,22	4,16
②	$\eta_{s,c}$	%	164	164	161	166	163	166	163
THAEBY MODEL SEASONAL PERFORMANCE IN HEATING MODE									
③	P _{designh} (EN 14825)	kW	95	104	119	134	149	170	200
③	SCOP (EN 14825)		3,38	3,4	3,67	3,36	3,64	3,35	3,53
④	η_s	%	132	133	144	131	142	131	138
THAESY MODEL SEASONAL PERFORMANCE IN HEATING MODE									
③	P _{designh} (EN 14825)	kW	92	102	115	131	146	167	197
③	SCOP (EN 14825)		3,47	3,49	3,71	3,5	3,73	3,39	3,62
④	η_s	%	136	136	145	137	146	133	142

① Low temperature application (7°C)

② Seasonal energy efficiency: low temperature cooling (EU Regulation 2016/2281)

③ In Average climatic conditions, low temperature application (35°C)

④ Seasonal energy efficiency: low temperature heating in Average climate (EU Regulations No.811/2013 and No.813/2013)

WinPACK SE

TCAEY-THAEY 2110÷4340

TCAEY-THAEY MODEL		4150	4170	4200	4220	4240	4270	4310	4340	
①	Nominal cooling capacity	kW	146,3	166,4	189,2	213,2	229,2	256	299,9	328,7
①	Nominal cooling capacity	kW	142,3	161,4	182,3	207,2	224,2	250	291	319,7
①	E.E.R.		2,99	2,9	2,83	2,92	2,8	2,8	2,81	2,76
①	E.E.R.		2,93	2,82	2,67	2,82	2,68	2,66	2,68	2,61
①	Absorbed power	kW	48,9	57,4	66,9	73	81,9	91,4	106,7	119,1
①	Absorbed power	kW	48,6	57,2	68,3	73,5	83,7	94	108,6	122,5
THAEY-THAEY MODEL		4150	4170	4200	4220	4240	4270	4310	4340	
②	Nominal heating capacity	kW	152,7	172,6	197,8	225,9	249	281,3	319,3	354,6
②	Nominal heating capacity	kW	147,7	167,6	192,8	219,9	245	278,3	315,2	345,5
②	C.O.P.		3,09	3,14	3,04	3,04	3,03	3,01	3,01	2,98
②	C.O.P.		3,1	3,12	3,09	3,09	3,09	3,05	3,07	3,03
①	Nominal cooling capacity	kW	141,3	163,4	186,2	209,1	227,1	253,9	295,9	324,7
①	Nominal cooling capacity	kW	136,4	156,4	180,3	200,2	220,2	248	286,1	313,8
②	Absorbed power	kW	49,4	55	65,1	74,3	82,2	93,5	106,1	119
②	Absorbed power	kW	47,6	53,7	62,4	71,2	79,3	91,2	102,7	114
TCAEY-THAEY-THAEY-THAEY MODEL		4150	4170	4200	4220	4240	4270	4310	4340	
③	TCAEY sound pressure	dB(A)	57	57	57	58	60	60	60	61
③	THAEY sound pressure	dB(A)	54	54	56	56	58	60	60	61
③	TCAESY sound pressure	dB(A)	51	51	51	52	54	54	56	57
③	THAESY sound pressure	dB(A)	50	50	52	52	54	55	56	57
④	TCAEY sound power	dB(A)	89	89	89	90	92	92	92	93
④	THAEY sound power	dB(A)	86	86	88	88	90	92	92	93
④	TCAESY sound power	dB(A)	83	83	83	84	86	86	88	89
④	THAESY sound power	dB(A)	82	82	84	84	86	87	88	89
	Scroll/step compressor	n.	4/4	4/4	4/4	4/4	4/4	4/4	4/4	4/4
	Circuits	n.	2	2	2	2	2	2	2	2
	Electrical supply	V-ph-Hz	400-3-50	400-3-50	400-3-50	400-3-50	400-3-50	400-3-50	400-3-50	400-3-50
DIMENSIONS AND WEIGHT		4150	4170	4200	4220	4240	4270	4310	4340	
	W - TCAEY-TCAESY width	mm	3600	3600	3600	4550	4550	4550	4800	4800
	W - THAEY-THAESY width	mm	3450	3450	3700	3700	4800	4800	4800	4800
	H - TCAEY-TCAESY height	mm	2440	2440	2440	2440	2440	2440	2030	2030
	H - THAEY-THAESY height	mm	2000	2000	2030	2030	2030	2030	2030	2030
	D - TCAEY-TCAESY depth	mm	1350	1350	1350	1350	1350	1350	2090	2090
	D - THAEY-THAESY depth	mm	1520	1520	2090	2090	2090	2090	2090	2090
⑤	TCAEY weight	kg	1165	1185	1190	1335	1670	1690	2400	2410
⑤	TCAESY weight	kg	1300	1320	1325	1470	1830	1850	2440	2450
⑤	THAEY weight	kg	1450	1525	1725	1800	2375	2460	2580	2595
⑤	THAESY weight	kg	1475	1550	1765	1840	2415	2500	2620	2635

Data at the following conditions:

- ① Air: 35°C - Water: 12/7°C.
- ② Air: 7°C, D.B. 6°C W.B. - Water: 40/45°C.
- ③ In open field (Q = 2) at 10 m from the unit.
- ④ Total sound power level in dB(A) based on measurements carried out in accordance with regulation UNI EN-ISO 9614.
- ⑤ Weight referred to the unit without load and not accessorised.

■ TCAESY-THAESY silenced versions.

Performance according to EN 14511.

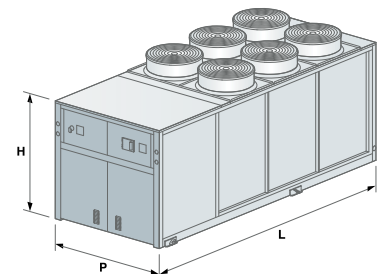

SEASONAL ENERGY PERFORMANCE		4150	4170	4200	4220	4240	4270	4310	4340	
TCAEBY MODEL SEASONAL PERFORMANCE IN COOLING MODE										
①	P _{designc} (EN 14825)	kW	146,3	166,4	189,2	213,2	229,2	256	299,9	328,6
①	SEER (EN 14825)		4,3	4,26	4,3	4,33	4,26	4,32	4,26	4,25
②	$\eta_{s,c}$	%	169	167	169	170	168	170	167	167
TCAESY MODEL SEASONAL PERFORMANCE IN COOLING MODE										
①	P _{designc} (EN 14825)	kW	142,3	161,4	182,3	207,2	224,2	250	291	319,7
①	SEER (EN 14825)		4,35	4,28	4,19	4,33	4,24	4,25	4,26	4,21
②	$\eta_{s,c}$	%	171	168	165	170	167	167	167	165
THAEBY MODEL SEASONAL PERFORMANCE IN HEATING MODE										
③	P _{designh} (EN 14825)	kW	129	145	168	192	211	240	271	301
③	SCOP (EN 14825)		3,41	3,47	3,33	3,33	3,35	3,33	3,34	3,32
④	η_s	%	133	136	130	130	131	130	131	130
THAESY MODEL SEASONAL PERFORMANCE IN HEATING MODE										
③	P _{designh} (EN 14825)	kW	125	140	164	187	207	238	267	292
③	SCOP (EN 14825)		3,41	3,45	3,4	3,4	3,44	3,39	3,41	3,37
④	η_s	%	134	135	133	133	135	132	133	132

① Low temperature application (7°C)

② Seasonal energy efficiency: low temperature cooling (EU Regulation 2016/2281)

③ In Average climatic conditions, low temperature application (35°C)

④ Seasonal energy efficiency: low temperature heating in Average climate (EU Regulations No.811/2013 and No.813/2013)

WinPACK-R HE-A

TCAETY-TCAEQY 4235÷4370

Cooling capacity: 221.4-372 kW



- High energy efficiency compact chillers
- Standard electronic expansion valve
- Integrated MASTER/SLAVE control



TCAETY 4290 with Tank&Pump and BCI, RPB, RPE, FI10 accessories

Packaged air-cooled water chillers with axial fans. Range with scroll hermetic compressors and R410A refrigerant.

Construction features

- Compressor: scroll type, rotary, hermetic complete with thermal protection and casing heater.
- 4 capacity steps with high efficiency at partial loads.
- Water side heat exchanger: with stainless steel plates, complete with closed cell polyurethane foam rubber insulation and water flow differential pressure switch.
- Air side heat exchanger: with micro-channels.
- Fan: external rotor axial type electric fans with internal thermal protection, accident protection grilles.
- Control: microprocessor electronic control with Adaptive Function Plus logic.
- Structure: load-bearing structure made of galvanised and painted steel plate with polyester powder coating.
- The unit is also complete with:
 - fan and compressor circuit breaker switches;
 - display of cooling circuit high and low pressure;
 - electronic expansion valve;
 - Master/Slave control up to 4 units in parallel;
 - clock board;
 - control of Variable Primary Flow (VPF_R).

Versions

- T - High efficiency version with oversized condensing section.
- Q - Super-silenced version complete with compressor technical compartment soundproofing, super-reduced speed fans and oversized condensing section.

Models

- TCAETY: high efficiency unit designed for cooling only.
- TCAEQY: super silenced unit designed for cooling only.

Factory fitted accessories

- Shell and tube evaporator.
- PUMP with single or double electric pump, one of which automatic in standby. The electric pumps are available in the low or high head versions.
- TANK&PUMP with 700 - 1000 litre integrated buffer tank (depending on models) and single or double electric pump, complete with expansion tank, air vent valves, safety valve and water side pressure gauge.
- Inverter pump control for unit start-up.
- Desuperheater.

- 100% heat recovery unit.
- Condensing control.
- Condensing control with fans with EC motor (standard in Q versions).
- Condensing control with over-pressure fans.
- Power factor correction capacitors ($\cos\phi > 0.94$).
- Forced limit of power consumption.
- Forced noise limit.
- Energy parameter measuring device.
- Optimised energy efficiency.
- Soft starter.
- Soundproofed compressor box.
- Compressor soundproof enclosures.
- Cooling circuit outlet and inlet valves.
- Refrigerant leak detector.
- Cooling circuit high and low pressure gauges.
- Double safety valves.
- Coil protection nets.
- Micro-channel coils with E-coating treatment.
- Control of min/max power supply voltage.
- Digital input for double set-point.
- 4-20 mA analogue signal for shifting set-point.
- Evaporator antifreeze heater, electrical panel, buffer tank, electric pumps and heat exchangers for heat recovery, if applicable.
- Low temperature water production.
- Interfaces for serial communication with other devices.
- Anti-vibration mounts.

Separately supplied accessories

- Remote keypad with display.
- Thermostat with display.
- Rhoss supervisors for unit monitoring and remote management.
- Rhoss sequencer for integrated management of multiple chillers.



TCAETY-TCAEQY MODEL		4235	4260	4290	4330	4370
① Nominal cooling capacity	kW	235,3	261,3	292,2	334	372
① Nominal cooling capacity	kW	221,4	243,4	269,4	312,1	343,1
① E.E.R.		3,27	3,2	3,12	3,19	3,15
① E.E.R.		3,12	2,88	2,68	2,89	2,75
① Absorbed power	kW	72	81,7	93,7	104,7	118,1
① Absorbed power	kW	71	84,5	100,5	108	124,8
TCAETY-TCAEQY MODEL		4235	4260	4290	4330	4370
② TCAETY sound pressure	dB(A)	59	60	61	62	63
② TCAEQY sound pressure	dB(A)	50	51	52	53	54
③ TCAETY sound power	dB(A)	91	92	93	94	95
③ TCAEQY sound power	dB(A)	82	83	84	85	86
Scroll/step compressor	n.	4/4	4/4	4/4	4/4	4/4
Circuits	n.	2	2	2	2	2
Electrical supply	V-ph-Hz	400-3-50	400-3-50	400-3-50	400-3-50	400-3-50
DIMENSIONS AND WEIGHTS		4235	4260	4290	4330	4371
L - Width	mm	3650	3650	3650	4750	4750
H - Height	mm	2450	2450	2450	2450	2450
P - Depth	mm	2260	2260	2260	2260	2260
④ TCAETY weight	kg	1620	1820	1985	2265	2310
④ TCAEQY weight	kg	1895	2095	2260	2540	2585

Data at the following conditions:

- ① Air: 35°C - Water: 12/7°C.
- ② In open field (Q = 2) at 10 m from the unit.
- ③ Total sound power level in dB(A) based on measurements carried out in accordance with regulation UNI EN-ISO 9614.
- ④ Weight referred to the unit without load and not accessorised.

■ TCAEQY super-silenced versions.

Performance according to EN 14511.

SEASONAL ENERGY PERFORMANCE		4235	4260	4290	4330	4370
TCAETY MODEL SEASONAL PERFORMANCE IN COOLING MODE						
① Pdesignc (EN 14825)	kW	235,3	261,3	292,2	334	372
① SEER (EN 14825)		4,45	4,46	4,44	4,6	4,54
② ηs,c	%	175	175	175	181	179
TCAEQY MODEL SEASONAL PERFORMANCE IN COOLING MODE						
① Pdesignc (EN 14825)	kW	221,4	243,4	269,4	312,1	343,1
① SEER (EN 14825)		4,39	4,34	4,32	4,43	4,42
② ηs,c	%	173	171	170	174	174

- ① Low temperature application (7°C)
- ② Seasonal energy efficiency: low temperature cooling (EU Regulation 2016/2281)

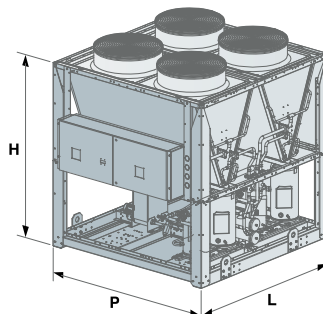

WinPACK-R SE

TCAEBY-TCAESY 4225÷4345

Cooling capacity: 214.2-345.7 kW



TCAESY 4245 with Tank&Pump and PTL, RPE accessories



- **Compact chillers also for replacement markets**
- **High performance range with extended operating limits**
- **Simplified installation thanks to pumping unit accessories**
- **Integrated MASTER/SLAVE control**

Packaged air-cooled water chillers with axial fans. Range with scroll hermetic compressors and R410A refrigerant.

Construction features

- Compressor: scroll type, rotary, hermetic complete with thermal protection and casing heater.
- 4 capacity steps with high efficiency at partial loads.
- Water side heat exchanger: with stainless steel plates, complete with closed cell polyurethane foam rubber insulation and water flow differential pressure switch.
- Air side heat exchanger: with micro-channels.
- Fan: external rotor axial type electric fans with internal thermal protection, accident protection grilles.
- Control: microprocessor electronic control with Adaptive Function Plus logic.
- Structure: load-bearing structure made of galvanised and painted steel plate with polyester powder coating.
- The unit is also complete with:
 - fan and compressor circuit breaker switches;
 - display of cooling circuit high and low pressure;
 - Master/Slave control up to 4 units in parallel;
 - clock board;
 - control of Variable Primary Flow (VPF_R).

Versions

- B - Standard version.
- S - Silenced version complete with compressor technical compartment soundproofing and reduced speed fans.

Models

- TCAEBY: standard unit designed for cooling only.
- TCAESY: silenced unit designed for cooling only.

Factory fitted accessories

- Shell and tube evaporator.
- PUMP with single or double electric pump, one of which automatic in standby. The electric pumps are available in the low or high head versions.
- TANK&PUMP with 500 - 700 litre integrated buffer tank (depending on models) and single or double electric pump, complete with expansion tank, air vent valves, safety valve and water side pressure gauge.
- Inverter pump control for unit start-up.

- Desuperheater.
- 100% heat recovery unit.
- Electronic expansion valve.
- Condensing control (standard in S versions).
- Condensing control with fans with EC motor.
- Condensing control with over-pressure fans.
- Power factor correction capacitors (cosφ > 0.94).
- Forced limit of power consumption.
- Forced noise limit.
- Energy parameter measuring device.
- Optimised energy efficiency.
- Soft starter.
- Soundproofed compressor box.
- Compressor soundproof enclosures.
- Cooling circuit outlet and inlet valves.
- Refrigerant leak detector.
- Cooling circuit high and low pressure gauges.
- Double safety valves.
- Coil protection nets.
- Micro-channel coils with E-coating treatment.
- Control of min/max power supply voltage.
- Digital input for double set-point.
- 4-20 mA analogue signal for shifting set-point.
- Evaporator antifreeze heater, electrical panel, buffer tank, electric pumps and heat exchangers for heat recovery, if applicable.
- Low temperature water production.
- Interfaces for serial communication with other devices.
- Anti-vibration mounts.

Separately supplied accessories

- Remote keypad with display.
- Thermostat with display.
- Rhoss supervisors for unit monitoring and remote management.
- Rhoss sequencer for integrated management of multiple chillers.



TCAEBY-TCAESY MODEL		4225	4245	4265	4315	4345
① Nominal cooling capacity	kW	220,2	241,2	264	313,9	345,7
① Nominal cooling capacity	kW	214,2	234,2	252,1	305	333,8
① E.E.R.		3	2,81	2,61	2,88	2,81
① E.E.R.		2,9	2,67	2,4	2,76	2,66
① Absorbed power	kW	73,4	85,8	101,1	108,9	123
① Absorbed power	kW	73,9	87,7	105	110,5	125,5
TCAEBY-TCAESY MODEL		4225	4245	4265	4315	4345
② Sound pressure	dB(A)	58	59	60	61	62
② Sound pressure	dB(A)	52	53	54	56	57
③ Sound power	dB(A)	90	91	92	93	94
③ Sound power	dB(A)	84	85	86	88	89
Scroll/step compressor	n.	4/4	4/4	4/4	4/4	4/4
Circuits	n.	2	2	2	2	2
Electrical supply	V-ph-Hz	400-3-50	400-3-50	400-3-50	400-3-50	400-3-50
DIMENSIONS AND WEIGHTS		4225	4245	4265	4315	4345
L - Width	mm	2550	2550	2550	3650	3650
H - Height	mm	2450	2450	2450	2450	2450
P - Depth	mm	2260	2260	2260	2260	2260
④ TCAEBY weight	kg	1300	1500	1650	1985	2000
④ TCAESY weight	kg	1460	1660	1810	2215	2230

Data at the following conditions:

- ① Air: 35°C - Water: 12/7°C.
- ② In open field (Q = 2) at 10 m from the unit.
- ③ Total sound power level in dB(A) based on measurements carried out in accordance with regulation UNI EN-ISO 9614.
- ④ Weight referred to the unit without load and not accessorised.

■ TCAESY silenced versions

Performance according to EN 14511.

SEASONAL ENERGY PERFORMANCE		4225	4245	4265	4315	4345
TCAEBY MODEL SEASONAL PERFORMANCE IN COOLING MODE						
① Pdesignc (EN 14825)	kW	220,2	241,2	264	313,9	345,7
① SEER (EN 14825)		4,31	4,31	4,3	4,34	4,34
② ηs,c	%	169	169	169	170	171
TCAESY MODEL SEASONAL PERFORMANCE IN COOLING MODE						
① Pdesignc (EN 14825)	kW	214,2	234,2	252,1	305	333,8
① SEER (EN 14825)		4,28	4,27	4,26	4,3	4,3
② ηs,c	%	168	168	167	169	169

- ① Low temperature application (7°C)
- ② Seasonal energy efficiency: low temperature cooling (EU Regulation 2016/2281)

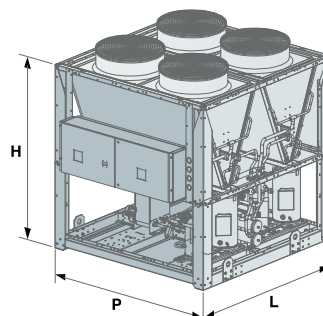

Y-Pack FREECOOLING

TFAEY-TGAEY 4160÷4320

Cooling capacity: 170-361 kW



TFAEY 4230 with coil protection nets accessory



- **NO GLYCOL version available**
- **Plug&Play Range**

Packaged air-cooled water chillers in Freecooling mode (TFAEY) and Freecooling NO-GLYCOL mode (TGAEY) with axial fans. Range with scroll hermetic compressors and R410A refrigerant.

Construction features

- Compressor: scroll type, rotary, hermetic complete with thermal protection and casing heater.
- 4 capacity steps with high efficiency at partial loads.
- Water side heat exchanger (evaporator): with stainless steel plates, complete with closed cell polyurethane foam rubber insulation and water flow differential pressure switch (TFAEY) or flow switch (TGAEY).
- Heat exchanger (water-water) in Freecooling NO-GLYCOL: with stainless steel plates, complete with closed cell polyurethane foam rubber insulation and water flow differential pressure switch.
- Air side heat exchanger (condenser): featuring finned coil with copper pipes and aluminium fins.
- Fan: external rotor axial type electric fans equipped with internal thermal protection, accident protection grilles and proportional electronic device for continuous fan rotation speed regulation.
- Control: microprocessor electronic control with Adaptive Function Plus logic.
- Structure: load-bearing structure made of galvanised and painted steel plate with polyester powder coating.
- The unit is also complete with:
 - fan and compressor circuit breaker switches;
 - clock board;
 - water side 3-way modulating valve.

Versions

- T - High efficiency version (TFAEY-TGAEY).
- S - Silenced version complete with compressor technical compartment soundproofing and reduced speed fans (TFAESY - TGAESY).

Models

- TFAEY: high efficiency unit in Freecooling mode.
- TFAESY: silenced unit in Freecooling mode.
- TGAEY: high efficiency unit in NO-GLYCOL Freecooling mode.
- TGAESY: silenced unit in NO-GLYCOL Freecooling mode.

Factory fitted accessories

- PUMP with single or double electric pump, including an automatic actuation pump in standby complete with safety valve. The electric pumps are available in the low or high head versions.
- Electronic expansion valve.
- Power factor correction capacitors ($\cos\phi > 0.94$).
- Soft starter.
- Cooling circuit high and low pressure gauges.
- Metal filters or coil protection nets.
- Copper/copper or copper/pre-painted aluminium coils.
- Digital input for double set-point.
- 4-20 mA analogue signal for shifting set-point.
- Evaporator antifreeze heater, electric pumps if applicable.
- Interfaces for serial communication with other devices.
- Anti-vibration mounts.

Separately supplied accessories

- Remote keypad with display.
- Rhoss supervisors for unit monitoring and remote management.

TFAETY-TFAESY MODEL		4160	4180	4200	4230	4260	4290	4320	
FREE-COOLING OFF									
❶	Nominal cooling capacity	kW	178	202	224	251	286	326	361
❶	Nominal cooling capacity	kW	170	197	215	240	274	312	344
❶	E.E.R.		3,31	3,41	3,27	3,2	3,34	3,2	3,09
❶	E.E.R.		3,21	3,32	3,11	3,11	3,22	3,09	2,92
❶	Absorbed power	kW	53,8	59,3	68,4	78,5	85,6	102	117
❶	Absorbed power	kW	53	59,3	69,2	77,2	85,2	100,9	117,9
FREE-COOLING ON 100%									
❷	Nominal cooling capacity	kW	178	202	224	251	286	326	361
❷	Nominal cooling capacity	kW	170	197	215	240	274	312	344
❷	E.E.R.		21,3	24,4	26,9	20,5	22,8	19,5	21,5
❷	E.E.R.		33	37,8	41,4	31,7	35,2	30	32,9
❷	Absorbed power	kW	8	8	8	12	12	16	16
❷	Absorbed power	kW	5	5	5	7,5	7,5	10	10
❷	Total Free-cooling Temperature	°C	0,3	1	0,4	0,7	0,9	0,4	-0,8
❷	Total Free-cooling Temperature	°C	-1,3	-0,8	-1,5	-1,3	-1,1	-1,6	-3,0
TFAETY-TFAESY MODEL			4160	4180	4200	4230	4260	4290	4320
❸	Sound pressure	dB(A)	60	63	63	65	65	66	66
❸	Sound pressure	dB(A)	55	56	56	58	59	60	60
❹	Sound power	dB(A)	89	91	91	93	93	94	94
❹	Sound power	dB(A)	85	86	86	88	89	90	90
	Scroll/step compressor	n.	4/4	4/4	4/4	4/4	4/4	4/4	4/4
	Circuits	n.	2	2	2	2	2	2	2
	Electrical supply	V-ph-Hz	400-3+N-50	400-3+N-50	400-3+N-50	400-3+N-50	400-3+N-50	400-3+N-50	400-3+N-50
DIMENSIONS AND WEIGHTS			4160	4180	4200	4230	4260	4290	4320
	L - Width	mm	4.800	4.800	4.800	4.800	5.300	5.300	5.300
	H - Height	mm	2.030	2.030	2.030	2.030	2.030	2.030	2.030
	P - Depth	mm	2.090	2.090	2.090	2.090	2.090	2.090	2.090
❺	TFAETY-TFAESY Weight	kg	2.370	2.820	2.920	3.020	3.230	3.380	3.430
❺	TGAETY-TGAESY Weight	kg	2.470	2.970	3.070	3.170	3.280	3.430	3.480

Data at the following conditions:

- ❶ Air: 30°C - Water: 15/10°C - Ethylene glycol 30%.
- ❷ Water: 15/10°C - Ethylene glycol 30%.
- ❸ In open field (Q = 2) at 10 m from the unit.
- ❹ Total sound power level in dB(A) based on measurements carried out in accordance with regulation UNI EN-ISO 9614.
- ❺ Weight referred to the accessorised unit without load.
- TFAESY silenced version.

SEASONAL ENERGY PERFORMANCE		4160	4180	4200	4230	4260	4290	4320	
TFAETY MODEL SEASONAL PERFORMANCE IN COOLING MODE									
❺	P _{designR}	kW	158,2	179,4	198,9	222,8	254	289,5	320,5
❺	SEPR		5,29	5,39	5,32	5,22	5,33	5,24	5,19
TFAESY MODEL SEASONAL PERFORMANCE IN COOLING MODE									
❺	P _{designR}	kW	151,2	175,1	191	213,1	243,5	277,1	305,5
❺	SEPR		5,28	5,31	5,24	5,19	5,27	5,21	5,14
TGAETY MODEL SEASONAL PERFORMANCE IN COOLING MODE									
❺	P _{designR}	kW	155,3	178,4	197,4	220,6	250,9	286,9	317,1
❺	SEPR		5,21	5,24	5,24	5,14	5,21	5,14	5,02
TGAESY MODEL SEASONAL PERFORMANCE IN COOLING MODE									
❺	P _{designR}	kW	148,5	171,6	188,9	211,1	240,7	274,2	300,9
❺	SEPR		5,1	5,16	5,18	5,16	5,15	5,02	5,02

- ❺ Application for high temperature (7°C) process chiller (EU Regulation 2016/2281)

WinPOWER ECO

TCAEU-THAEU 4370÷6660

Cooling capacity: 359.7-664.5 kW - Heating capacity: 368.3-654.5 kW



- **Efficient and eco-friendly range in R454B**
- **SEER up to 5.38 with FIEC accessory (EC fans)**
- **Extended operating limits**
- **Up to 6 capacity steps**
- **Integrated MASTER/SLAVE control**



TCAEU 6660
with PTL1, BCI accessory

Air cooled water chillers and reversible heat pumps with axial fans.

Range with scroll hermetic compressors and R454B refrigerant.

Construction features

- Compressor: scroll type, rotary, hermetic complete with thermal protection and casing heater.
- Up to 6 capacity steps with high efficiency at partial loads.
- Water side heat exchanger: with stainless steel plates, complete with closed cell polyurethane foam rubber insulation, water flow differential pressure switch and Victaulic fittings.
- Air side heat exchanger: featuring micro-channels (TCAEU) or finned coil with copper pipes and aluminium fins (THAEU).
- Fan: external rotor axial type electric fans equipped with internal thermal protection, accident protection grilles and proportional electronic device for continuous fan rotation speed adjustment.
- Control: microprocessor electronic control with Adaptive Function Plus logic.
- Structure: load-bearing structure made of galvanised and painted steel plate with polyester powder coating.
- The unit is also complete with:
 - fan and compressor circuit breaker switches;
 - display of cooling circuit high and low pressure;
 - electronic expansion valve;
 - clock board;
 - Master/Slave control up to 4 units in parallel;
 - control of Variable Primary Flow (VPF_R).

Versions

- T - High efficiency version (TCAEU - THAEU).
- Q - Super silenced version complete with compressor technical compartment soundproofing and reduced speed fans (TCAEUQ - THAEUQ).

Models

- TCAEU: high efficiency unit designed for cooling only.
- TCAEUQ: super silenced unit designed for cooling only.
- THAEU: high efficiency heat pump unit.
- THAEUQ: super silenced heat pump unit.



Factory fitted accessories

- Shell and tube evaporator.
- PUMP with single or double electric pump, one of which automatic in standby. The electric pumps are available in the low or high head versions.
- TANK&PUMP with 700 or 1000 litre integrated buffer tank (depending on size) and single or double electric pump, complete with expansion tank, air vent valves, safety valve and water side pressure gauge.
- Inverter pump control for unit start-up.
- Desuperheater.
- 100% heat recovery unit (TCAEU).
- Condensing control with fans with EC motor.
- Condensing control with over-pressure fans (T version only).
- Power factor correction capacitors ($\cos\phi > 0.94$).
- Forced limit of power consumption.
- Forced noise limit.
- Energy parameter measuring device.
- Soft starter.
- Soundproofed compressor box or Compressor box and soundproofed cooling circuit (THAEU).
- Compressor soundproof enclosures.
- Cooling circuit outlet and intake valves (TCAEU).
- Cooling circuit outlet valves (THAEU).
- Refrigerant leak detector.
- Cooling circuit high and low pressure gauges.
- Double safety valves
- Coil protection nets or buffer panels.
- Microchannel coils with E-coating treatment, copper/copper, pre-painted copper/aluminium or with hydrophilic treatment depending on versions.
- Control of min/max power supply voltage.
- Digital input for double set-point.
- 4-20 mA analogue signal for shifting set-point.
- Evaporator antifreeze heater, electrical panel, coil tanks, buffer tank, electric pumps and heat exchangers for heat recovery, if applicable.
- Low temperature water production.
- Interfaces for serial communication with other devices.

- Colour touch user keypad (fitted on the machine or remotely) with 7" display.
- Spring anti-vibration mounts.
- Protective packaging.

Separately supplied accessories

- Remote keypad with display.
- Thermostat with display.
- Rhoss supervisors for unit monitoring and remote management.
- Rhoss sequencer for integrated management of multiple chillers.

WinPOWER ECO

TCAEU-THAEU 4370÷6660

TCAEU-TCAEU MODEL		4370	4410	4450	5490	5520	5560	6600	6630	6660	
❶	Nominal cooling capacity	kW	374,7	407,7	450,6	490,6	521,6	562,5	604,5	632,6	664,5
❶	Nominal cooling capacity	kW	365,7	398,7	438,6	479,6	510,6	546,6	593,5	618,6	645,5
❶	E.E.R.		3,36	3,32	3,27	3,3	3,27	3,26	3,28	3,27	3,26
❶	E.E.R.		3,26	3,23	3,12	3,21	3,18	3,12	3,22	3,18	3,12
❶	Absorbed power	kW	110,5	121,7	136,8	147,5	158,3	170,9	182,2	191,8	201,9
❶	Absorbed power	kW	111,2	122,5	139,3	148,4	159,1	173,9	182,7	193,3	205,6
TCAEU-TCAEU MODEL		4370	4410	4450	5490	5520	5560	6600	6630	6660	
❸	TCAEU sound pressure	dB(A)	62	62,5	62,5	63,5	63,5	63,5	64	64	65
❸	TCAEU sound pressure	dB(A)	54	54,5	54,5	55,5	55,5	55,5	56	56	56
❹	TCAEU sound power	dB(A)	94	95	95	96	96	96	97	97	98
❹	TCAEU sound power	dB(A)	86	87	87	88	88	88	89	89	89
	Scroll/step compressor	n.	4/4	4/4	4/4	5/5	5/5	5/5	6/6	6/6	6/6
	Circuits	n.	2	2	2	2	2	2	2	2	2
	Electrical supply	V-ph-Hz	400-3-50	400-3-50	400-3-50	400-3-50	400-3-50	400-3-50	400-3-50	400-3-50	400-3-50
DIMENSIONS AND WEIGHTS		4370	4410	4450	5490	5520	5560	6600	6630	6660	
	L - Width	mm	4840	4840	4840	5940	5940	5940	7100	7100	7100
	H - Height	mm	2480	2480	2480	2480	2480	2480	2480	2480	2480
	P - Depth	mm	2260	2260	2260	2260	2260	2260	2260	2260	2260
❺	TCAEU weight	kg	2545	2645	2690	3190	3230	3265	3910	3960	3990
❺	TCAEU weight	kg	2790	2890	2920	3465	3505	3540	4240	4290	4320
THAETU-THAEU MODEL		4370	4410	4450	5490	5520	5560	6600	6630	6660	
❷	Nominal heating capacity	kW	374,3	405,3	440,4	488,4	513,4	552,4	597,5	628,4	654,5
❷	Nominal heating capacity	kW	368,3	400,3	434,4	480,4	505,4	544,4	588,5	618,4	645,5
❷	C.O.P.		3,41	3,34	3,32	3,37	3,36	3,35	3,35	3,33	3,34
❷	C.O.P.		3,47	3,41	3,37	3,42	3,41	3,41	3,4	3,38	3,38
❶	Nominal cooling capacity	kW	367,7	400,7	440,6	484,6	505,6	553,5	597,5	623,6	654,5
❶	Nominal cooling capacity	kW	359,7	390,7	429,7	472,6	493,6	538,6	583,5	607,6	637,5
❶	E.E.R.		3,34	3,24	3,21	3,22	3,21	3,2	3,27	3,25	3,24
❶	E.E.R.		3,25	3,14	3,08	3,12	3,1	3,06	3,16	3,13	3,1
❷	Absorbed power	kW	109,3	122,8	136,1	149,3	156,5	171,4	181,2	190,3	200,5
❷	Absorbed power	kW	109,7	123,6	138,3	150,4	158,1	174,3	182,8	192,5	203,8
THAETU-THAEU MODEL		4370	4410	4450	5490	5520	5560	6600	6630	6660	
❸	THAETU sound pressure	dB(A)	62	62,5	62,5	63,5	63,5	63,5	64	64	65
❸	THAEU sound pressure	dB(A)	54	54,5	54,5	55,5	55,5	55,5	56	56	56
❹	THAETU sound power	dB(A)	94	95	95	96	96	96	97	97	98
❹	THAEU sound power	dB(A)	86	87	87	88	88	88	89	89	89
	Scroll/step compressor	n.	4/4	4/4	4/4	5/5	5/5	5/5	6/6	6/6	6/6
	Circuits	n.	2	2	2	2	2	2	2	2	2
	Electrical supply	V-ph-Hz	400-3-50	400-3-50	400-3-50	400-3-50	400-3-50	400-3-50	400-3-50	400-3-50	400-3-50
DIMENSIONS AND WEIGHTS		4370	4410	4450	5490	5520	5560	6600	6630	6660	
	L - Width	mm	4840	4840	4840	5940	5940	5940	7100	7100	7100
	H - Height	mm	2480	2480	2480	2480	2480	2480	2480	2480	2480
	P - Depth	mm	2260	2260	2260	2260	2260	2260	2260	2260	2260
❺	THAETU weight	kg	2545	2645	2690	3190	3230	3265	3910	3960	3990
❺	THAEU weight	kg	2790	2890	2920	3465	3505	3540	4240	4290	4320

Data at the following conditions:

- ❶ Air: 35°C - Water: 12/7°C.
 - ❷ Air: 7°C, D.B. 6°C W.B. - Water: 40/45°C.
 - ❸ In open field (Q = 2) at 10 m from the unit.
 - ❹ Total sound power level in dB(A) based on measurements carried out in accordance with regulation UNI EN-ISO 9614.
 - ❺ Weight referred to the unit without load and not accessorised.
- TCAEU super-silenced versions.
Performance according to EN 14511.

SEASONAL ENERGY PERFORMANCE		4370	4410	4450	5490	5520	5560	6600	6630	6660
TCAETU MODEL SEASONAL PERFORMANCE IN COOLING MODE										
①	P _{designc} (EN 14825)	kW	374,7	407,7	450,6	490,6	521,6	562,5	604,5	664,5
①	SEER (EN 14825)		4,99	4,84	4,81	4,99	4,92	4,86	5,03	4,96
②	η _{s,c}	%	196	190	189	197	194	191	198	195
TCAEQU MODEL SEASONAL PERFORMANCE IN COOLING MODE										
①	P _{designc} (EN 14825)	kW	365,7	398,7	438,6	479,6	510,6	546,6	593,5	645,5
①	SEER (EN 14825)		4,95	4,79	4,76	4,97	4,9	4,84	4,99	4,91
②	η _{s,c}	%	195	189	187	196	193	191	196	193
THAETU MODEL SEASONAL PERFORMANCE IN COOLING MODE										
①	P _{designc} (EN 14825)	kW	-	-	-	484,6	505,6	553,5	597,5	654,5
①	SEER (EN 14825)		-	-	-	4,95	4,86	4,82	4,97	4,9
②	η _{s,c}	%	-	-	-	195	191	190	196	195
THAEQU MODEL SEASONAL PERFORMANCE IN COOLING MODE										
①	P _{designc} (EN 14825)	kW	-	-	-	-	493,6	538,6	583,5	637,5
①	SEER (EN 14825)		-	-	-	-	4,84	4,79	4,94	4,87
②	η _{s,c}	%	-	-	-	-	191	189	195	192
THAETU MODEL SEASONAL PERFORMANCE IN HEATING MODE										
③	P _{designh} (EN 14825)	kW	307	335	363	-	-	-	-	-
③	SCOP (EN 14825)		3,87	3,83	3,81	-	-	-	-	-
④	η _s	%	152	150	149	-	-	-	-	-
THAEQU MODEL SEASONAL PERFORMANCE IN HEATING MODE										
③	P _{designh} (EN 14825)	kW	303	330	358	397	-	-	-	-
③	SCOP (EN 14825)		3,93	3,89	3,85	3,88	-	-	-	-
④	η _s	%	154	153	151	152	-	-	-	-

- ① Low temperature application (7°C)
- ② Seasonal energy efficiency: low temperature cooling (EU Regulation 2016/2281)
- ③ In Average climatic conditions, low temperature application (35°C)
- ④ Seasonal energy efficiency: low temperature heating in Average climate (EU Regulations No.811/2013 and No.813/2013)

WinPOWER HE-A

TCAEY 4385÷8920 / THAEY 4385÷6700

Cooling capacity: 354.2-916.8 kW - Heating capacity: 383.3-698.9 kW

TCAEY 4415
with BCI, PTL, RPE accessory

- **High energy efficiency chillers**
- **Extended operating limits**
- **Up to 6 capacity steps**
- **Multi-purpose for systems with 2 pipes + DHW (with optional RC100)**
- **Built-in MASTER/SLAVE control**

Air cooled water chillers and reversible heat pumps with axial fans.

Range with scroll hermetic compressors and R410A refrigerant.

Construction features

- Compressor: scroll type, rotary, hermetic complete with thermal protection and casing heater.
- Up to 6 capacity steps with high efficiency at partial loads.
- Water side heat exchanger: with stainless steel plates, complete with closed cell polyurethane foam rubber insulation, water flow differential pressure switch and Victaulic fittings.
- Air side heat exchanger: featuring micro-channels (TCAEY) or finned coil with copper pipes and aluminium fins (THAEY).
- Fan: external rotor axial type electric fans, equipped with internal thermal protection, accident protection grilles and a proportional electronic device for continuous fan rotation speed regulation (T version; fans with an EC motor are standard in the Q version).
- Control: microprocessor electronic control with

Adaptive Function Plus logic.

- Structure: load-bearing structure made of galvanised and painted steel plate with polyester powder coating.
- The unit is also complete with:
 - fan and compressor circuit breaker switches;
 - display of cooling circuit high and low pressure;
 - electronic expansion valve;
 - clock board;
 - Master/Slave control up to 4 units in parallel;
 - control of Variable Primary Flow (VPF_R).

Versions

- T - High efficiency version with oversized condensing section (TCAEY - THAEY).
- Q - Super-silenced version complete with compressor technical compartment soundproofing, reduced speed fans and oversized condensing section (TCAEQY-THAEQY).

Models

- TCAEY: high efficiency unit designed for cooling only.
- TCAEQY: super silenced unit designed for cooling only.
- THAEY: high efficiency heat pump unit.
- THAEQY: super silenced heat pump unit.



TCAEQY 8920



THAET 4460
with BFI accessory

Factory fitted accessories

- Shell and tube evaporator.
- PUMP with single or double electric pump, one of which automatic in standby. The electric pumps are available in the low or high head versions.
- TANK&PUMP with 700 or 1000 litre integrated buffer tank (depending on size) and single or double electric pump, complete with expansion tank, air vent valves, safety valve and water side pressure gauge.
- Inverter pump control for unit start-up (TCAETY, TCAEQY, THAET).
- Desuperheater.
- 100% heat recovery unit.
- Condensing control with fans with EC motor (standard in Q versions).
- Condensing control with over-pressure fans.
- Power factor correction capacitors ($\cos\phi > 0.94$).
- Forced limit of power consumption.
- Forced noise limit.
- Energy parameter measuring device.
- Soft starter.
- Soundproofed compressor box or Compressor box and soundproofed cooling circuit (THAET).
- Compressor soundproof enclosures.
- Cooling circuit outlet and inlet valves.
- Refrigerant leak detector.
- Cooling circuit high and low pressure gauges.
- Double safety valves
- Metal filters (THAET) or coil protection nets.

- Microchannel coils with E-coating treatment, copper/copper or pre-painted copper/aluminium depending on the versions.
- Control of min/max power supply voltage.
- Digital input for double set-point.
- 4-20 mA analogue signal for shifting set-point.
- Evaporator antifreeze heater, electrical panel, buffer tank, electric pumps and heat exchangers for heat recovery, if applicable.
- Low temperature water production.
- Interfaces for serial communication with other devices.
- Anti-vibration mounts.

Separately supplied accessories

- Remote keypad with display.
- Thermostat with display.
- Rhoss supervisors for unit monitoring and remote management.
- Rhoss sequencer for integrated management of multiple chillers.

WinPOWER HE-A

TCAEY 4385÷8920 / THAEY 4385÷6700

TCAEY-TCAEQY MODEL		4385	4415	4460	5525	6570	6625	
①	Nominal cooling capacity	kW	385	414	460,8	524,5	569,5	623,1
①	Nominal cooling capacity	kW	372,1	400	440,9	492,7	535,7	585,4
①	E.E.R.		3,24	3,16	3,13	3,19	3,17	3,1
①	E.E.R.		3,12	2,97	2,9	2,98	2,89	2,7
①	Absorbed power	kW	118,9	131,1	147,3	164,5	179,7	201
①	Absorbed power	kW	119,3	134,7	152	165,3	185,4	216,8
TCAEY-TCAEQY MODEL		4385	4415	4460	5525	6570	6625	
③	TCAEY sound pressure	dB(A)	62,5	63,5	64,5	64,5	64,5	64,5
③	TCAEQY sound pressure	dB(A)	54,5	54,5	55,5	55,5	55,5	55,5
④	TCAEY sound power	dB(A)	95	96	97	97	97	97
④	TCAEQY sound power	dB(A)	87	87	88	88	88	88
	Scroll/step compressor	n.	4/4	4/4	4/4	5/5	6/6	6/6
	Circuits	n.	2	2	2	2	2	2
	Electrical supply	V-ph-Hz	400-3-50	400-3-50	400-3-50	400-3-50	400-3-50	400-3-50
DIMENSIONS AND WEIGHTS		4385	4415	4460	5525	6570	6625	
	L - Width	mm	4840	4840	4840	5940	5940	5940
	H - Height	mm	2450	2450	2450	2450	2450	2450
	P - Depth	mm	2260	2260	2260	2260	2260	2260
⑤	TCAEY weight	kg	2440	2460	2510	2980	3200	3210
⑤	TCAEQY weight	kg	2715	2735	2785	3300	3565	3575

THAEY-THAEQY MODEL		4385	4415	4460	5525	6570	6625	
②	Nominal heating capacity	kW	386,9	425	464,2	520,4	571,5	626,8
②	Nominal heating capacity	kW	383,3	420,8	458,3	512,5	556,2	622,1
②	C.O.P.		3,2	3,2	3,2	3,2	3,2	3,2
②	C.O.P.		3,33	3,3	3,3	3,28	3,28	3,29
①	Nominal cooling capacity	kW	359,2	399	439,9	498,7	538,6	584,4
①	Nominal cooling capacity	kW	354,2	385,1	421,1	474,8	507,8	546,6
①	E.E.R.		2,97	2,96	2,95	3,02	2,95	2,9
①	E.E.R.		2,91	2,82	2,75	2,84	2,72	2,53
②	Absorbed power	kW	121	132,9	145,1	162,7	178,6	195,9
②	Absorbed power	kW	115,1	127,5	138,9	156,3	169,6	189,1
THAEY-THAEQY MODEL		4385	4415	4460	5525	6570	6625	
③	THAEY sound pressure	dB(A)	62,5	63,5	64,5	64,5	64,5	64,5
③	THAEQY sound pressure	dB(A)	54,5	54,5	55,5	55,5	55,5	55,5
④	THAEY sound power	dB(A)	95	96	97	97	97	97
④	THAEQY sound power	dB(A)	87	87	88	88	88	88
	Scroll/step compressor	n.	4/4	4/4	4/4	5/5	6/6	6/6
	Circuits	n.	2	2	2	2	2	2
	Electrical supply	V-ph-Hz	400-3-50	400-3-50	400-3-50	400-3-50	400-3-50	400-3-50
DIMENSIONS AND WEIGHTS		4385	4415	4460	5525	6570	6625	
	L - Width	mm	4840	4840	4840	5940	5940	5940
	H - Height	mm	2450	2450	2450	2450	2450	2450
	P - Depth	mm	2260	2260	2260	2260	2260	2260
⑤	THAEY weight	kg	3030	3200	3250	3830	4040	4070
⑤	THAEQY weight	kg	3395	3565	3615	4310	4520	4550

Data at the following conditions:

- ① Air: 35°C - Water: 12/7°C.
 - ② Air: 7°C, D.B. 6°C W.B. - Water: 40/45°C.
 - ③ In open field (Q = 2) at 10 m from the unit.
 - ④ Total sound power level in dB(A) based on measurements carried out in accordance with regulation UNI EN-ISO 9614.
 - ⑤ Weight referred to the unit without load and not accessorised.
- TCAEQY super-silenced versions.
Performance according to EN 14511.

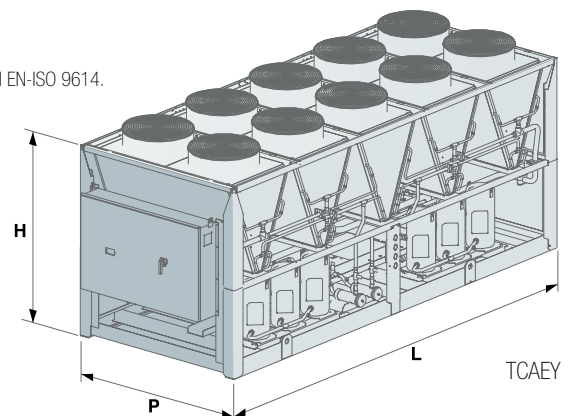

SEASONAL ENERGY PERFORMANCE		4385	4415	4460	5525	6570	6625	
TCAETY MODEL SEASONAL PERFORMANCE IN COOLING MODE								
①	P _{designc} (EN 14825)	kW	385	414	460,8	524,5	569,5	623,1
①	SEER (EN 14825)		4,78	4,75	4,77	4,76	4,78	4,77
②	$\eta_{s,c}$	%	188	187	188	187	188	188
TCAEQY MODEL SEASONAL PERFORMANCE IN COOLING MODE								
①	P _{designc} (EN 14825)	kW	372,1	400	440,9	492,7	535,7	585,4
①	SEER (EN 14825)		4,91	4,91	4,89	4,91	4,86	4,87
②	$\eta_{s,c}$	%	193	193	192	193	191	192
THAETY MODEL SEASONAL PERFORMANCE IN COOLING MODE								
①	P _{designc} (EN 14825)	kW	-	-	439,9	498,7	538,6	584,3
①	SEER (EN 14825)		-	-	4,68	4,68	4,66	4,67
②	$\eta_{s,c}$	%	-	-	184	184	184	184
THAEQY MODEL SEASONAL PERFORMANCE IN COOLING MODE								
①	P _{designc} (EN 14825)	kW	-	-	421,1	474,8	507,8	546,6
①	SEER (EN 14825)		-	-	4,81	4,81	4,82	4,81
②	$\eta_{s,c}$	%	-	-	189	189	190	189
THAETY MODEL SEASONAL PERFORMANCE IN HEATING MODE								
③	P _{designh} (EN 14825)	kW	354	388	-	-	-	-
③	SCOP (EN 14825)		3,53	3,56	-	-	-	-
④	η_s	%	138	139	-	-	-	-
THAEQY MODEL SEASONAL PERFORMANCE IN HEATING MODE								
③	P _{designh} (EN 14825)	kW	350	385	-	-	-	-
③	SCOP (EN 14825)		3,8	3,8	-	-	-	-
④	η_s	%	149	149	-	-	-	-

① Low temperature application (7°C)

② Seasonal energy efficiency: low temperature cooling (EU Regulation 2016/2281)

③ In Average climatic conditions, low temperature application (35°C)

④ Seasonal energy efficiency: low temperature heating in Average climate (EU Regulations No.811/2013 and No.813/2013)

WinPOWER HE-A

TCAEY 4385÷8920 / THAEY 4385÷6700

TCAEY-TCAEQY MODEL		6665	6700	7760	8820	8870	8920
①	Nominal cooling capacity	kW	665,3	695,2	758,3	819,9	916,8
①	Nominal cooling capacity	kW	634,5	663,5	728,6	790,1	867,6
①	E.E.R.		3,16	3,13	3,14	3,15	3,13
①	E.E.R.		2,96	2,91	2,93	2,93	2,86
①	Absorbed power	kW	210,6	222,2	241,5	260,3	277,1
①	Absorbed power	kW	214,4	228	248,7	269,7	303,4
TCAEY-TCAEQY MODEL		6665	6700	7760	8820	8870	8920
③	TCAEY sound pressure	dB(A)	65,5	65,5	65,5	65,5	66
③	TCAEQY sound pressure	dB(A)	56,5	57,5	58	58	59
④	TCAEY sound power	dB(A)	98	98	98	98	99
④	TCAEQY sound power	dB(A)	89	90	91	91	92
	Scroll/step compressor	n.	6/6	6/6	7/6	8/6	8/6
	Circuits	n.	2	2	2	2	2
	Electrical supply	V-ph-Hz	400-3-50	400-3-50	400-3-50	400-3-50	400-3-50
DIMENSIONS AND WEIGHTS		6665	6700	7760	8820	8870	8920
	L - Width	mm	7100	7100	8250	9350	9350
	H - Height	mm	2450	2450	2450	2450	2450
	P - Depth	mm	2260	2260	2260	2260	2260
⑤	TCAEY weight	kg	3715	3740	4250	4650	4770
⑤	TCAEQY weight	kg	4080	4105	4655	5105	5225

THAEY-THAEQY MODEL		6665	6700
②	Nominal heating capacity	kW	662,6
②	Nominal heating capacity	kW	656,1
②	C.O.P.		3,21
②	C.O.P.		3,33
①	Nominal cooling capacity	kW	633,5
①	Nominal cooling capacity	kW	606,7
①	E.E.R.		3,02
①	E.E.R.		2,8
②	Absorbed power	kW	206,5
②	Absorbed power	kW	197
THAEY-THAEQY MODEL		6665	6700
③	THAEY sound pressure	dB(A)	65,5
③	THAEQY sound pressure	dB(A)	56,5
④	THAEY sound power	dB(A)	98
④	THAEQY sound power	dB(A)	89
	Scroll/step compressor	n.	6/6
	Circuits	n.	2
	Electrical supply	V-ph-Hz	400-3-50
DIMENSIONS AND WEIGHTS		6665	6700
	L - Width	mm	6840
	H - Height	mm	2450
	P - Depth	mm	2260
⑤	THAEY weight	kg	4680
⑤	THAEQY weight	kg	5210

Data at the following conditions:

- ① Air: 35°C - Water: 12/7°C.
 - ② Air: 7°C, D.B. 6°C W.B. - Water: 40/45°C.
 - ③ In open field (Q = 2) at 10 m from the unit.
 - ④ Total sound power level in dB(A) based on measurements carried out in accordance with regulation UNI EN-ISO 9614.
 - ⑤ Weight referred to the unit without load and not accessorised.
- TCAEQY super-silenced versions.
Performance according to EN 14511.

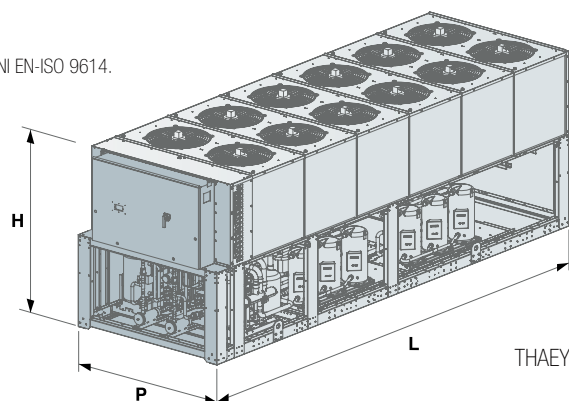

SEASONAL ENERGY PERFORMANCE		6665	6700	7760	8820	8870	8920	
TCAETY MODEL SEASONAL PERFORMANCE IN COOLING MODE								
①	P _{designc} (EN 14825)	kW	665,3	695,2	758,3	819,9	870	916,8
①	SEER (EN 14825)		4,76	4,77	4,77	4,76	4,76	4,77
②	$\eta_{s,c}$	%	187	188	188	188	187	188
TCAEQY MODEL SEASONAL PERFORMANCE IN COOLING MODE								
①	P _{designc} (EN 14825)	kW	634,5	663,5	728,6	790,1	830,2	867,6
①	SEER (EN 14825)		4,88	4,9	4,85	4,86	4,88	4,87
②	$\eta_{s,c}$	%	192	193	191	191	192	192
THAETY MODEL SEASONAL PERFORMANCE IN COOLING MODE								
①	P _{designc} (EN 14825)	kW	633,5	660,3	-	-	-	-
①	SEER (EN 14825)		4,65	4,68	-	-	-	-
②	$\eta_{s,c}$	%	183	184	-	-	-	-
THAEQY MODEL SEASONAL PERFORMANCE IN COOLING MODE								
①	P _{designc} (EN 14825)	kW	606,7	631,5	-	-	-	-
①	SEER (EN 14825)		4,83	4,84	-	-	-	-
②	$\eta_{s,c}$	%	190	191	-	-	-	-
THAETY MODEL SEASONAL PERFORMANCE IN HEATING MODE								
③	P _{designh} (EN 14825)	kW	-	-	-	-	-	-
③	SCOP (EN 14825)		-	-	-	-	-	-
④	η_s	%	-	-	-	-	-	-
THAEQY MODEL SEASONAL PERFORMANCE IN HEATING MODE								
③	P _{designh} (EN 14825)	kW	-	-	-	-	-	-
③	SCOP (EN 14825)		-	-	-	-	-	-
④	η_s	%	-	-	-	-	-	-

① Low temperature application (7°C)

② Seasonal energy efficiency: low temperature cooling (EU Regulation 2016/2281)

③ In Average climatic conditions, low temperature application (35°C)

④ Seasonal energy efficiency: low temperature heating in Average climate (EU Regulations No.811/2013 and No.813/2013)

WinPOWER SE

TCAEY 4360÷8860

Cooling capacity: 359.8-861.8 kW



TCAEY 4435
with Tank&Pump and
RPB, RPE accessories



- **Version B compact and high-performance for replacement markets**
- **Up to 6 capacity steps**
- **Simplified installation thanks to pumping unit accessories**
- **Built-in MASTER/SLAVE control**

Air cooled water chillers with axial fans.
Range with scroll hermetic compressors and R410A refrigerant.

Construction features

- Compressor: scroll type, rotary, hermetic complete with thermal protection and casing heater.
- Up to 6 capacity steps with high efficiency at partial loads.
- Water side heat exchanger: with stainless steel plates, complete with closed cell polyurethane foam rubber insulation, water flow differential pressure switch and Victaulic fittings.
- Air side heat exchanger: with micro-channels.
- Fan: external rotor axial type electric fans equipped with internal thermal protection, accident protection grilles and proportional electronic device for continuous fan rotation speed regulation.
- Control: microprocessor electronic control with Adaptive Function Plus logic.
- Structure: load-bearing structure made of galvanised and painted steel plate with polyester powder coating.
- The unit is also complete with:
 - fan and compressor circuit breaker switches;

- display of cooling circuit high and low pressure;
- electronic expansion valve;
- clock board;
- Master/Slave control up to 4 units in parallel;
- control of Variable Primary Flow (VPF_R).

Versions

- B - Base version (TCAEY).

Models

- TCAEY: unit intended for cooling only.



TCAEBY 8860
with BCI accessory

Factory fitted accessories

- Shell and tube evaporator.
- PUMP with single or double electric pump, one of which automatic in standby. The electric pumps are available in the low or high head versions.
- TANK&PUMP with 700 or 1000 litre integrated buffer tank (depending on size) and single or double electric pump, complete with expansion tank, air vent valves, safety valve and water side pressure gauge.
- Desuperheater.
- 100% heat recovery unit.
- Condensing control with fans with EC motor.
- Condensing control with over-pressure fans.
- Power factor correction capacitors ($\cos\phi > 0.94$).
- Forced limit of power consumption.
- Forced noise limit.
- Energy parameter measuring device.
- Soft starter.
- Soundproofed compressor box.
- Compressor soundproof enclosures.
- Cooling circuit outlet and inlet valves.
- Refrigerant leak detector.
- Cooling circuit high and low pressure gauges.
- Double safety valves.
- Coil protection nets.

- Micro-channel coils with E-coating treatment.
- Control of min/max power supply voltage.
- Digital input for double set-point.
- 4-20 mA analogue signal for shifting set-point.
- Evaporator antifreeze heater, electrical panel, buffer tank, electric pumps and heat exchangers for heat recovery, if applicable.
- Low temperature water production.
- Interfaces for serial communication with other devices.
- Anti-vibration mounts.

Separately supplied accessories

- Remote keypad with display.
- Thermostat with display.
- Rhoss supervisors for unit monitoring and remote management.
- Rhoss sequencer for integrated management of multiple chillers.

WinPOWER SE

TCAEY 4360÷8860

TCAEY MODEL		4360	4390	4435	5500	6540	6590
① Nominal cooling capacity	kW	359,8	389,6	434,6	496,3	538,9	587,9
① E.E.R.		2,9	2,84	2,81	2,96	2,9	2,77
① Absorbed power	kW	124,1	137,2	154,7	167,7	185,9	212,3
TCAEY MODEL		4360	4390	4435	5500	6540	6590
② Sound pressure	dB(A)	62	63	64	64	64	64
③ Sound power	dB(A)	94	95	96	96	96	96
Scroll/step compressor	n.	4/4	4/4	4/4	5/5	6/6	6/6
Circuits	n.	2	2	2	2	2	2
Electrical supply	V-ph-Hz	400-3-50	400-3-50	400-3-50	400-3-50	400-3-50	400-3-50
DIMENSIONS AND WEIGHTS		4360	4390	4435	5500	6540	6590
L - Width	mm	3740	3740	3740	4840	4840	4840
H - Height	mm	2450	2450	2450	2450	2450	2450
P - Depth	mm	2260	2260	2260	2260	2260	2260
④ TCAEY weight	kg	2130	2140	2200	2670	2860	2890

Data at the following conditions:

- ① Air: 35°C - Water: 12/7°C.
- ② In open field (Q = 2) at 10 m from the unit.
- ③ Total sound power level in dB(A) based on measurements carried out in accordance with regulation UNI EN-ISO 9614.
- ④ Weight referred to the unit without load and not accessorised.

Performance according to EN 14511.

SEASONAL ENERGY PERFORMANCE		4360	4390	4435	5500	6540	6590
TCAEY MODEL SEASONAL PERFORMANCE IN COOLING MODE							
① P _{design,c} (EN 14825)	kW	359,8	389,6	434,6	496,3	538,9	587,9
① SEER (EN 14825)		4,6	4,59	4,58	4,58	4,61	4,56
② $\eta_{s,c}$	%	181	180	180	180	181	179

- ① Low temperature application (7°C)
- ② Seasonal energy efficiency: low temperature cooling (EU Regulation 2016/2281)

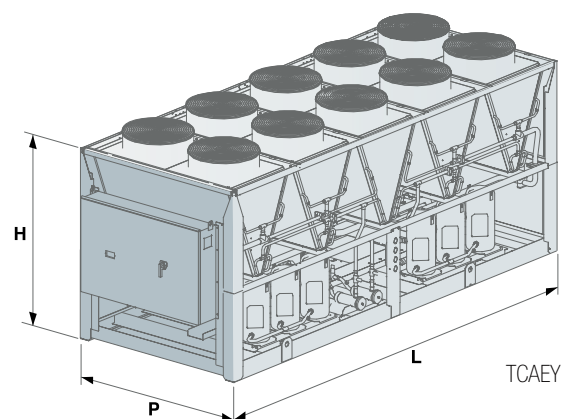

TCAEBY MODEL		6635	6670	7730	8790	8830	8860
① Nominal cooling capacity	kW	637,7	666,5	732,4	784	827,1	861,8
① E.E.R.		2,93	2,9	2,93	2,84	2,81	2,8
① Absorbed power	kW	217,7	229,9	250	276,1	294,4	307,8
TCAEBY MODEL		6635	6670	7730	8790	8830	8860
② Sound pressure	dB(A)	64,5	64,5	64,5	64,5	65	66
③ Sound power	dB(A)	97	97	97	97	98	99
Scroll/step compressor	n.	6/6	6/6	7/6	8/6	8/6	8/6
Circuits	n.	2	2	2	2	2	2
Electrical supply	V-ph-Hz	400-3-50	400-3-50	400-3-50	400-3-50	400-3-50	400-3-50
DIMENSIONS AND WEIGHTS		6635	6670	7730	8790	8830	8860
L - Width	mm	5940	5940	7150	7150	7150	7150
H - Height	mm	2450	2450	2450	2450	2450	2450
P - Depth	mm	2260	2260	2260	2260	2260	2260
④ TCAEBY weight	kg	3205	3230	3870	4020	4100	4120

Data at the following conditions:

- ① Air: 35°C - Water: 12/7°C.
- ② In open field (Q = 2) at 10 m from the unit.
- ③ Total sound power level in dB(A) based on measurements carried out in accordance with regulation UNI EN-ISO 9614.
- ④ Weight referred to the unit without load and not accessorised.

Performance according to EN 14511.

SEASONAL ENERGY PERFORMANCE		6635	6670	7730	8790	8830	8860
TCAEBY MODEL SEASONAL PERFORMANCE IN COOLING MODE							
① P _{designc} (EN 14825)	kW	637,7	666,5	732,4	784	827,1	861,8
① SEER (EN 14825)		4,6	4,6	4,57	4,58	4,57	4,57
② $\eta_{s,c}$	%	181	181	180	180	180	180

- ① Low temperature application (7°C)
- ② Seasonal energy efficiency: low temperature cooling (EU Regulation 2016/2281)

FullPOWER VFD

TCAITZ-TCAIQZ 2565÷21005

Cooling capacity: 510-1001.5 kW

INVERTERTCAITZ 2565
with BCI60 accessory

- **Variable Vi screw compressor suitable for all applications**
- **Continuous power regulation from 12.5 to 100%**
- **High efficiency levels**
- **Wide range of accessories**
- **Built-in MASTER/SLAVE control**

Packaged air-cooled water chillers with axial fans.

Range with semi-hermetic screw compressors with variable Vi, inverter regulation and R134a refrigerant gas.

Construction features

- Compressor: high energy efficiency semi-hermetic screw compressor with variable Vi intrinsic compression ratio, star-delta limited start, inverter rotation regulation, complete with integral protection, casing heater, oil level sensor and refrigerant gas outlet piping shut-off valve.
- Water side heat exchanger: dry expansion shell and tube exchanger with counterflow heat exchange, complete with closed cell polyurethane foam rubber insulation, water flow differential pressure switch and Victaulic fittings.
- Air side heat exchanger: with micro-channels.
- Fan: external rotor axial type electric fans, equipped with internal thermal protection, accident protection grilles and a proportional electronic device for continuous fan rotation speed regulation (T version; fans with an EC motor are standard in the Q version).
- Control: microprocessor electronic control.
- Structure: made of galvanised and painted steel plate with polyester powder coating.
- The unit is also complete with:
 - display of cooling circuit high/low pressure;
 - electronic expansion valve;
 - clock board;
 - Master/Slave control up to 4 units in parallel;
 - control of Variable Primary Flow (VPF_R).

Versions

- T - High efficiency version with oversized condensing section (TCAITZ).
- Q - Super-silenced version complete with compressor technical compartment soundproofing, super-reduced speed fans and oversized condensing section (TCAIQZ).

Models

- TCAITZ: high efficiency unit designed for cooling only.
- TCAIQZ: super silenced unit designed for cooling only.

Factory fitted accessories

- PUMP with single or double electric pump, one of which automatic in standby. The electric pumps are available in the low or high head versions.
- Inverter pump control for unit start-up.
- Desuperheater.
- 100% heat recovery unit.
- Condensing control with fans with EC motor (standard in Q versions).
- Condensing control with over-pressure fans.
- Power factor correction capacitors ($\cos\phi > 0.94$).
- Compressor circuit breaker switches.
- Electro-mechanical flow switch.
- EMC anti-disturbance filters.
- Forced limit of power consumption.
- Forced noise limit.
- Energy parameter measuring device.
- Soundproofed compressor box.
- Cooling circuit intake valves.
- Refrigerant leak detector.
- Cooling circuit high and low pressure gauges.
- Double safety valves.
- Coil protection nets.
- Micro-channel coils with E-coating treatment.
- Control of min/max power supply voltage.
- Digital input for double set-point.
- 4-20 mA analogue signal for shifting set-point.
- Evaporator antifreeze heater, electrical panel, electric pumps and heat exchangers for heat recovery if applicable.
- Interfaces for serial communication with other devices.
- Anti-vibration mounts.

Separately supplied accessories

- Remote keypad with display.
- Thermostat with display.
- Rhoss supervisors for unit monitoring and remote management.
- Rhoss sequencer for integrated management of multiple chillers.



TCAITZ-TCAIQZ MODEL		2565	2615	2685	2775	2845	2945	21005	
①	Nominal cooling capacity	kW	562,4	610,9	680,5	772,5	844,9	1001,5	
①	Nominal cooling capacity	kW	510	555,4	633	717,9	791,5	934,2	
①	E.E.R.		3,11	3,15	3,13	3,13	3,11	3,11	
①	E.E.R.		2,77	2,85	2,79	2,86	2,78	2,79	
①	Absorbed power	kW	180,8	193,9	217,4	246,8	271,7	301,3	
①	Absorbed power	kW	184,1	194,9	226,9	251	284,7	303,8	
TCAITZ-TCAIQZ MODEL			2565	2615	2685	2775	2845	2945	21005
②	Sound pressure	dB(A)	69,5	70	70	71	71	72	
②	Sound pressure	dB(A)	59,5	60	60	61	62	63	
③	Sound power	dB(A)	102	103	103	104	104	105	
③	Sound power	dB(A)	92	93	93	94	95	96	
Screw/step compressor		n.	2/ REGOLAZIONE CONTINUA						
Circuits		n.	2	2	2	2	2	2	
Electrical supply		V-ph-Hz	400-3-50	400-3-50	400-3-50	400-3-50	400-3-50	400-3-50	
DIMENSIONS AND WEIGHTS			2565	2615	2685	2775	2845	2945	21005
L - Width		mm	6090	7250	7250	8350	8350	10550	
H - Height		mm	2450	2450	2450	2450	2450	2450	
P - Depth		mm	2260	2260	2260	2260	2260	2260	
④	TCAITZ weight	kg	4220	4650	4750	5070	5190	5850	
④	TCAIQZ weight	kg	4600	5050	5150	5470	5590	6250	

Data at the following conditions:

- ① Air: 35°C - Water: 12/7°C.
 - ② In open field (Q = 2) at 10 m from the unit.
 - ③ Total sound power level in dB(A) based on measurements carried out in accordance with regulation UNI EN-ISO 9614.
 - ④ Weight referred to the unit without load and not accessorised.
- TCAIQZ super-silenced versions.
Performance according to EN 14511.

SEASONAL ENERGY PERFORMANCE		2565	2615	2685	2775	2845	2945	21005
TCAITZ MODEL SEASONAL PERFORMANCE IN COOLING MODE								
①	P _{design,c} (EN 14825)	kW	562,4	610,9	680,5	772,5	844,9	1001,5
①	SEER (EN 14825)		5,31	5,24	5,28	5,26	5,26	5,29
②	η _{s,c}	%	209	206	208	207	207	208
TCAIQZ MODEL SEASONAL PERFORMANCE IN COOLING MODE								
①	P _{design,c} (EN 14825)	kW	510	555,4	633	717,9	791,5	934,2
①	SEER (EN 14825)		5,06	5,06	5,05	5,03	5,07	5,11
②	η _{s,c}	%	199	200	199	198	200	202

- ① Low temperature application (7°C)
- ② Seasonal energy efficiency: low temperature cooling (EU Regulation 2016/2281)

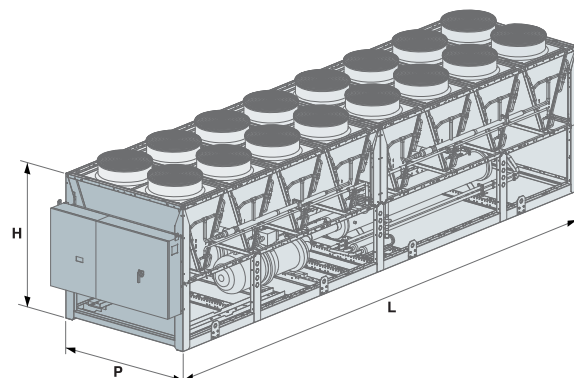

FullPOWER VFD (1+i)

TCAITZ-TCAIQZ 2560÷21310

Cooling capacity: 518-1307.4 kW

INVERTER



TCAITZ 2560
with BCI60 accessory

- Continuous power regulation from 12.5 to 100%
- High efficiency levels
- Wide range of accessories
- Integrated MASTER/SLAVE control

Air cooled water chillers with axial fans.
Range with stepless semi-hermetic screw compressors and variable Vi with inverter regulation and R134a refrigerant gas.

Construction features

- Compressor: high energy efficiency semi-hermetic screw driven by fixed speed motor with linear capacity control and variable Vi regulated by inverter (12.5-100%), limited inrush start, complete with integral protection, casing heater, oil level sensor and shut-off valve on refrigerant gas outlet piping.
- Water side heat exchanger: dry expansion shell and tube exchanger with counterflow heat exchange, complete with closed cell polyurethane foam rubber insulation, water flow differential pressure switch and Victaulic fittings.
- Air side heat exchanger: with micro-channels.
- Fan: external rotor axial type electric fans, equipped with internal thermal protection, accident protection grilles and a proportional electronic device for continuous fan rotation speed regulation (T version; fans with an EC motor are standard in the Q version).
- Control: microprocessor electronic control.
- Structure: made of galvanised and painted steel plate with polyester powder coating.
- The unit is also complete with:
 - display of cooling circuit high/low pressure;
 - electronic expansion valve;
 - clock board;
 - Master/Slave control up to 4 units in parallel;
 - control of Variable Primary Flow (VPF_R).

Versions

- T - High efficiency version with oversized condensing section (TCAITZ).
- Q - Super-silenced version complete with compressor technical compartment soundproofing, super-reduced speed fans and oversized condensing section (TCAIQZ).

Models

- TCAITZ: high efficiency unit designed for cooling only.
- TCAIQZ: super silenced unit designed for cooling only.

Factory fitted accessories

- PUMP with single or double electric pump, one of which automatic in standby. The electric pumps are available in the low or high head versions.
- Inverter pump control for unit start-up.
- Desuperheater.
- 100% heat recovery unit.
- Condensing control with fans with EC motor (standard in Q versions).
- Condensing control with over-pressure fans.
- Power factor correction capacitors ($\cos\phi > 0.94$).
- Compressor circuit breaker switches.
- Electro-mechanical flow switch.
- EMC anti-disturbance filters.
- Forced limit of power consumption.
- Forced noise limit.
- Energy parameter measuring device.
- Soft starter
- Soundproofed compressor box.
- Cooling circuit intake valves.
- Refrigerant leak detector.
- Cooling circuit high and low pressure gauges.
- Double safety valves.
- Coil protection nets.
- Micro-channel coils with E-coating treatment.
- Control of min/max power supply voltage.
- Digital input for double set-point.
- 4-20 mA analogue signal for shifting set-point.
- Evaporator antifreeze heater, electrical panel, electric pumps and heat exchangers for heat recovery if applicable.
- Interfaces for serial communication with other devices.
- Anti-vibration mounts.

Separately supplied accessories

- Remote keypad with display.
- Thermostat with display.
- Rhoss supervisors for unit monitoring and remote management.
- Rhoss sequencer for integrated management of multiple chillers.



TCAITZ-TCAIQZ MODEL		2560	2600	2670	2710	2770	2860	2930	2980	21080	21160	21310	
❶	Nominal cooling capacity	kW	561,4	602,2	671,6	712,3	766,5	861,7	933,1	978,8	1079,8	1156,8	1307,4
❶	Nominal cooling capacity	kW	517,9	553,5	633,9	670,7	707	804,2	869,5	909,4	1009,5	1067,6	1192,4
❶	E.E.R.		3,11	3,17	3,15	3,13	3,19	3,15	3,23	3,2	3,16	3,16	3,17
❶	E.E.R.		2,74	2,86	2,79	2,76	2,85	2,8	2,84	2,83	2,82	2,81	2,81
❶	Absorbed power	kW	180,5	189,9	213,2	227,6	240,3	273,6	288,9	305,9	341,7	366,1	412,4
❶	Absorbed power	kW	189	193,5	227,2	243	248,1	287,2	306,2	321,3	357,9	379,9	424,3
TCAITZ-TCAIQZ MODEL		2560	2600	2670	2710	2770	2860	2930	2980	21080	21160	21310	
❷	Sound pressure	dB(A)	68,5	69	69	69	70	70	71	71	71	71	72
❷	Sound pressure	dB(A)	58,5	59	59	59	60	61	61	61	62	62	63
❸	Sound power	dB(A)	101	102	102	102	103	103	104	104	104	104	105
❸	Sound power	dB(A)	91	92	92	92	93	94	94	94	95	95	96
	Screw/step compressor	n.	1+i / REGOLAZIONE CONTINUA										
	Circuits	n.	2	2	2	2	2	2	2	2	2	2	2
	Electrical supply	V-ph-Hz	400-3-50	400-3-50	400-3-50	400-3-50	400-3-50	400-3-50	400-3-50	400-3-50	400-3-50	400-3-50	400-3-50
DIMENSIONS AND WEIGHTS		2560	2600	2670	2710	2770	2860	2930	2980	21080	21160	21310	
	L - Width	mm	6090	7250	7250	7250	8350	8350	9400	10550	10550	10550	11750
	H - Height	mm	2450	2450	2450	2450	2450	2450	2450	2450	2450	2450	2450
	P - Depth	mm	2260	2260	2260	2260	2260	2260	2260	2260	2260	2260	2260
❹	TCAITZ weight	kg	4390	4770	4840	4850	5690	5790	6250	6500	6610	6970	7330
❹	TCAIQZ weight	kg	4770	5170	5240	5250	6090	6190	6650	6900	7010	7370	7730

Data at the following conditions:

- ❶ Air: 35°C - Water: 12/7°C.
- ❷ In open field (Q = 2) at 10 m from the unit.
- ❸ Total sound power level in dB(A) based on measurements carried out in accordance with regulation UNI EN-ISO 9614.
- ❹ Weight referred to the unit without load and not accessorised.

■ TCAIQZ super-silenced versions.
Performance according to EN 14511.

SEASONAL ENERGY PERFORMANCE		2560	2600	2670	2710	2770	2860	2930	2980	21080	21160	21310	
TCAITZ MODEL SEASONAL PERFORMANCE IN COOLING MODE													
❶	P _{design,c} (EN 14825)	kW	561,4	602,2	671,6	712,3	766,5	861,7	933,1	978,8	1079,8	1156,8	1307,4
❶	SEER (EN 14825)		4,95	4,94	4,97	4,94	4,94	4,99	4,93	4,97	4,95	4,96	4,97
❷	η _{s,c}	%	195	195	196	194	195	196	194	196	195	195	196
TCAIQZ MODEL SEASONAL PERFORMANCE IN COOLING MODE													
❶	P _{design,c} (EN 14825)	kW	517,9	553,5	633,9	670,7	707	804,2	869,5	909,4	1009,5	1067,6	1192,4
❶	SEER (EN 14825)		4,83	4,85	4,84	4,85	4,87	4,85	4,84	4,84	4,87	4,83	4,88
❷	η _{s,c}	%	190	191	191	191	192	191	191	191	192	190	192

- ❶ Low temperature application (7°C)
- ❷ Seasonal energy efficiency: low temperature cooling (EU Regulation 2016/2281)

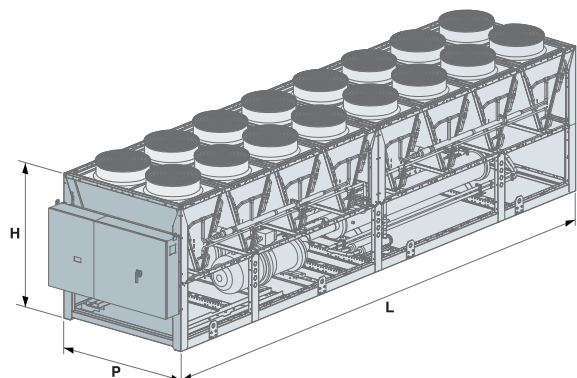

FULLPOWER HE-A

TCAVTZ-TCAVQZ 2345÷21335

Cooling capacity: 329-1325 kW



TCAVQZ 2715

TCAVTZ 2425
with FIAP and BCI accessory

- **High energy efficiency chillers**
- **Extended operating limits**
- **Linear capacity control (25-100%)**
- **Wide range of accessories**
- **Built-in MASTER/SLAVE control**

Air cooled water chillers with axial fans.
Range with semi-hermetic screw compressors and R134a refrigerant gas.

Construction features

- Compressor: high energy efficiency semi-hermetic screw compressor with linear capacity control (25-100%). Star-delta limited start and complete with integral protection, casing heater and refrigerant gas outlet piping shut-off valve.
- Water side heat exchanger: dry expansion shell and tube exchanger with counterflow heat exchange, complete with closed cell polyurethane foam rubber insulation, water flow differential pressure switch and Victaulic fittings.
- Air side heat exchanger: with micro-channels.
- Fan: external rotor axial type electric fans, equipped with internal thermal protection, accident protection grilles and a proportional electronic device for continuous fan rotation speed regulation (T version; fans with an EC motor are standard in the Q version).
- Control: microprocessor electronic control.
- Structure: made of galvanised and painted steel plate with polyester powder coating.
- The unit is also complete with:
 - display of cooling circuit high/low pressure;
 - electronic expansion valve;
 - clock board;
 - Master/Slave control up to 4 units in parallel;
 - control of Variable Primary Flow (VPF_R).

Versions

- T - High efficiency version with oversized condensing section (TCAVTZ).
- Q - Super-silenced version complete with soundproof compressor technical compartment, reduced speed fans and oversized condensing section (TCAVQZ).

Models

- TCAVTZ: high efficiency unit designed for cooling only.
- TCAVQZ: super silenced unit designed for cooling only.

Factory fitted accessories

- PUMP with single or double electric pump, one of which automatic in standby. The electric pumps are available in the low or high head versions.
- Inverter pump control for unit start-up.
- Desuperheater.
- 100% heat recovery unit.
- Condensing control with fans with EC motor (standard in Q versions).
- Condensing control with over-pressure fans.
- Power factor correction capacitors ($\cos\phi > 0.94$).
- Compressor circuit breaker switches.
- Electro-mechanical flow switch.
- Oil level sensor.
- Forced limit of power consumption.
- Forced noise limit.
- Energy parameter measuring device.
- Soft starter.
- Soundproofed compressor box.
- Cooling circuit intake valves.
- Refrigerant leak detector.
- Cooling circuit high and low pressure gauges.
- Double safety valves.



TCAVTZ 2585
with BCI accessory and P1 pump unit

- Coil protection nets.
- Micro-channel coils with E-coating treatment.
- Control of min/max power supply voltage.
- Digital input for double set-point.
- 4-20 mA analogue signal for shifting set-point.
- Evaporator antifreeze heater, electrical panel, electric pumps and heat exchangers for heat recovery if applicable.
- Low temperature water production.
- Interfaces for serial communication with other devices.
- Anti-vibration mounts.

Separately supplied accessories

- Remote keypad with display.
- Thermostat with display.
- Rhoss supervisors for unit monitoring and remote management.
- Rhoss sequencer for integrated management of multiple chillers.

FullPOWER HE-A

TCAVTZ-TCAVQZ 2345÷21335

TCAVTZ-TCAVQZ MODEL		2345	2385	2425	2475	2525	2585	2655	2715
① Nominal cooling capacity	kW	339,9	379,6	423,7	474,3	524,8	577,3	655,8	712,2
① Nominal cooling capacity	kW	329	370,6	408,8	475,3	506	552,5	632	693,3
① E.E.R.		3,24	3,23	3,2	3,23	3,2	3,18	3,23	3,21
① E.E.R.		3,16	3,14	3,05	3,14	3,04	2,91	2,98	2,92
① Absorbed power	kW	104,9	117,5	132,4	146,8	164	181,5	203	221,9
① Absorbed power	kW	104,1	118,0	134,0	151,4	166,4	189,9	212,1	237,4
TCAVTZ-TCAVQZ MODEL		2345	2385	2425	2475	2525	2585	2655	2715
② Sound pressure	dB(A)	65,5	65,5	65,5	65,5	65,5	66,5	66,5	66,5
② Sound pressure	dB(A)	56,5	56,5	56,5	56,5	56,5	57,5	57,5	57,5
③ Sound power	dB(A)	98	98	98	98	98	99	99	99
③ Sound power	dB(A)	89	89	89	89	89	90	90	90
Screw/step compressor	n.	2/ REGOLAZIONE CONTINUA LINEARE (25-100%)							
Circuits	n.	2	2	2	2	2	2	2	2
Electrical supply	V-ph-Hz	400-3-50	400-3-50	400-3-50	400-3-50	400-3-50	400-3-50	400-3-50	400-3-50
DIMENSIONS AND WEIGHTS		2345	2385	2425	2475	2525	2585	2655	2715
L - Width	mm	4840	4840	4840	5990	5990	5990	7150	7150
H - Height	mm	2450	2450	2450	2450	2450	2450	2450	2450
P - Depth	mm	2260	2260	2260	2260	2260	2260	2260	2260
④ TCAVTZ weight	kg	3040	3045	3070	3415	4170	4200	4690	4720
④ TCAVQZ weight	kg	3315	3320	3345	3690	4550	4580	5090	5120

Data at the following conditions:

- ① Air: 35°C - Water: 12/7°C.
 - ② In open field (Q = 2) at 10 m from the unit.
 - ③ Total sound power level in dB(A) based on measurements carried out in accordance with regulation UNI EN-ISO 9614.
 - ④ Weight referred to the unit without load and not accessorised.
- TCAVQZ super-silenced versions.
Performance according to EN 14511.

SEASONAL ENERGY PERFORMANCE		2345	2385	2425	2475	2525	2585	2655	2715
TCAVTZ MODEL SEASONAL PERFORMANCE IN COOLING MODE									
① P _{designc} (EN 14825)	kW	339,9	379,6	423,7	474,3	524,8	577,3	655,8	712,2
① SEER (EN 14825)		4,75	4,74	4,7	4,76	4,73	4,74	4,73	4,74
② $\eta_{s,c}$	%	187	187	185	187	186	187	186	187
TCAVQZ MODEL SEASONAL PERFORMANCE IN COOLING MODE									
① P _{designc} (EN 14825)	kW	329	370,6	408,8	475,3	506	552,5	632	693,3
① SEER (EN 14825)		4,83	4,81	4,83	4,82	4,82	4,83	4,83	4,81
② $\eta_{s,c}$	%	190	189	190	190	190	190	190	189

- ① Low temperature application (7°C)
- ② Seasonal energy efficiency: low temperature cooling (EU Regulation 2016/2281)

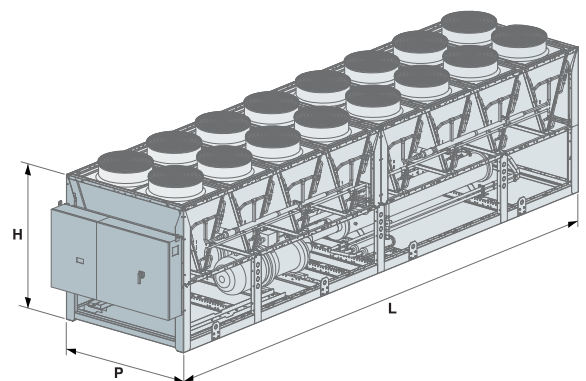

TCAVTZ-TCAVQZ MODEL		2765	2815	2885	2955	21025	21105	21175	21335
①	Nominal cooling capacity	kW	760,7	813,3	879,7	955,9	1020,5	1100,8	1324,5
①	Nominal cooling capacity	kW	746,9	787,6	835,1	912,2	970,9	1051,2	1279,1
①	E.E.R.		3,19	3,24	3,19	3,27	3,22	3,2	3,17
①	E.E.R.		2,91	3,03	2,89	2,99	2,9	2,93	2,87
①	Absorbed power	kW	238,5	251	275,8	292,3	316,9	344	368,2
①	Absorbed power	kW	256,7	259,9	289,0	305,1	334,8	358,8	442,6
TCAVTZ-TCAVQZ MODEL		2765	2815	2885	2955	21025	21105	21175	21335
②	Sound pressure	dB(A)	67	67	68	68	68	69	69
②	Sound pressure	dB(A)	58	59	60	60	60	60	61
③	Sound power	dB(A)	100	100	101	101	101	102	102
③	Sound power	dB(A)	91	91	93	93	93	93	94
Screw/step compressor		n.	2/ REGOLAZIONE CONTINUA LINEARE (25-100%)						
Circuits		n.	2	2	2	2	2	2	2
Electrical supply		V-ph-Hz	400-3-50	400-3-50	400-3-50	400-3-50	400-3-50	400-3-50	400-3-50
DIMENSIONS AND WEIGHTS		2765	2815	2885	2955	21025	21105	21175	21335
L - Width		mm	7150	8250	8250	9350	9350	10450	11550
H - Height		mm	2450	2450	2450	2450	2450	2450	2450
P - Depth		mm	2260	2260	2260	2260	2260	2260	2260
④	TCAVTZ weight	kg	4740	5565	5995	6520	6585	6950	7355
④	TCAVQZ weight	kg	5140	5965	6395	6920	6985	7350	7755

Data at the following conditions:

- ① Air: 35°C - Water: 12/7°C.
 - ② In open field (Q = 2) at 10 m from the unit.
 - ③ Total sound power level in dB(A) based on measurements carried out in accordance with regulation UNI EN-ISO 9614.
 - ④ Weight referred to the unit without load and not accessorised.
- TCAVQZ super-silenced versions.
Performance according to EN 14511.

SEASONAL ENERGY PERFORMANCE		2765	2815	2885	2955	21025	21105	21175	21335
TCAVTZ MODEL SEASONAL PERFORMANCE IN COOLING MODE									
①	P _{design,c} (EN 14825)	kW	760,7	813,3	879,7	955,9	1020,5	1100,8	1324,5
①	SEER (EN 14825)		4,75	4,71	4,73	4,71	4,75	4,75	4,76
②	η _{s,c}	%	187	185	186	185	187	187	187
TCAVQZ MODEL SEASONAL PERFORMANCE IN COOLING MODE									
①	P _{design,c} (EN 14825)	kW	746,9	787,6	835,1	912,2	970,9	1051,2	1279,1
①	SEER (EN 14825)		4,83	4,83	4,84	4,83	4,81	4,83	4,82
②	η _{s,c}	%	190	190	191	190	189	190	190

- ① Low temperature application (7°C)
- ② Seasonal energy efficiency: low temperature cooling (EU Regulation 2016/2281)

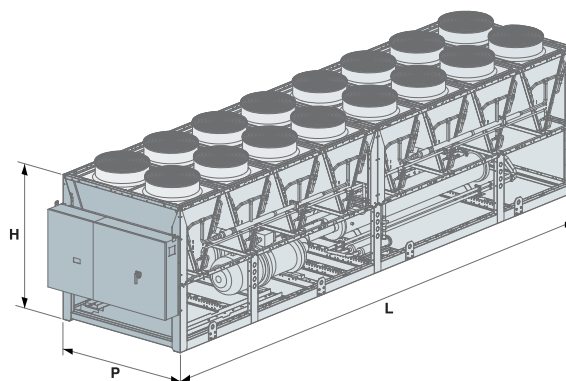

FULLPOWER SE

TCAVBZ 2335÷21275

Cooling capacity: 328.8-1271 kW



TCAVBZ 2865
with BCI accessory

TCAVBZ 2515
with FIAP and BCI accessory

- Efficient range in R134a
- Operation up to -50°C outdoor air
- Linear capacity control (25-100%)
- Wide range of accessories
- Integrated MASTER/SLAVE control

Air cooled water chillers with axial fans.
Range with semi-hermetic screw compressors and R134a refrigerant gas.

Construction features

- Compressor: high energy efficiency semi-hermetic screw compressor with linear capacity control (25-100%). Star-delta limited start and complete with integral protection, casing heater and refrigerant gas outlet piping shut-off valve.
- Water side heat exchanger: dry expansion shell and tube exchanger with counterflow heat exchange, complete with closed cell polyurethane foam rubber insulation, water flow differential pressure switch and Victaulic fittings.
- Air side heat exchanger: with micro-channels.
- Fan: external rotor axial type electric fans equipped with internal thermal protection, accident protection grilles and proportional electronic device for continuous fan rotation speed regulation.
- Control: microprocessor electronic control.
- Structure: made of galvanised and painted steel plate with polyester powder coating.
- The unit is also complete with:
 - display of cooling circuit high/low pressure;
 - electronic expansion valve;
 - clock board;
 - Master/Slave control up to 4 units in parallel;
 - control of Variable Primary Flow (VPF_R).

Versions

- B - Standard version (TCAVBZ).

Models

- TCAVBZ: unit designed for cooling only.

Factory fitted accessories

- PUMP with single or double electric pump, one of which automatic in standby. The electric pumps are available in the low or high head versions.
- Desuperheater.
- 100% heat recovery unit.
- Condensing control with fans with EC motor.
- Condensing control with over-pressure fans.
- Power factor correction capacitors ($\cos\phi > 0.94$).
- Compressor circuit breaker switches.
- Electro-mechanical flow switch.
- Oil level sensor.
- Forced limit of power consumption.
- Forced noise limit.
- Energy parameter measuring device.
- Soft starter.
- Soundproofed compressor box.
- Cooling circuit intake valves.
- Refrigerant leak detector.
- Cooling circuit high and low pressure gauges.
- Double safety valves.
- Coil protection nets.
- Micro-channel coils with E-coating treatment.
- Control of min/max power supply voltage.
- Digital input for double set-point.
- 4-20 mA analogue signal for shifting set-point.
- Evaporator antifreeze heater, electrical panel, electric pumps and heat exchangers for heat recovery if applicable.
- Low temperature water production.
- Interfaces for serial communication with other devices.
- Anti-vibration mounts.



TCAVBZ 21275
with MCHXE accessory

Separately supplied accessories

- Remote keypad with display.
- Thermostat with display.
- Rhoss supervisors for unit monitoring and remote management.
- Rhoss sequencer for integrated management of multiple chillers.

FULLPOWER SE

TCAVBZ 2335÷21275

TCAVBZ MODEL		2335	2365	2405	2465	2515	2565	2645	2705	
①	Nominal cooling capacity	kW	328,8	364,4	400,4	460	512,8	559,6	641,2	701,6
①	E.E.R.		3,01	2,9	2,85	3,01	2,91	2,85	2,94	2,91
①	Absorbed power	kW	109,2	125,7	140,5	152,8	176,2	196,4	218,1	241,1
TCAVBZ MODEL		2335	2365	2405	2465	2515	2565	2645	2705	
②	Sound pressure	dB(A)	65	65	66	66	66	66	66,5	66,5
③	Sound power	dB(A)	97	97	98	98	98	98	99	99
	Screw/step compressor	n.	2/ REGOLAZIONE CONTINUA LINEARE (25-100%)							
	Circuits	n.	2	2	2	2	2	2	2	
	Electrical supply	V-ph-Hz	400-3-50	400-3-50	400-3-50	400-3-50	400-3-50	400-3-50	400-3-50	
DIMENSIONS AND WEIGHTS		2335	2365	2405	2465	2515	2565	2645	2705	
	L - Width	mm	3740	3740	3740	4840	4840	4840	5990	5990
	H - Height	mm	2450	2450	2450	2450	2450	2450	2450	2450
	P - Depth	mm	2260	2260	2260	2260	2260	2260	2260	2260
④	TCAVBZ weight	kg	2700	2710	2730	3140	3700	3910	4230	4260

Data at the following conditions:

- ① Air: 35°C - Water: 12/7°C.
- ② In open field (Q = 2) at 10 m from the unit.
- ③ Total sound power level in dB(A) based on measurements carried out in accordance with regulation UNI EN-ISO 9614.
- ④ Weight referred to the unit without load and not accessorised.

Performance according to EN 14511.

SEASONAL ENERGY PERFORMANCE		2335	2365	2405	2465	2515	2565	2645	2705	
TCAVBZ MODEL SEASONAL PERFORMANCE IN COOLING MODE										
①	P _{design,c} (EN 14825)	kW	328,8	364,4	400,4	460	512,8	559,6	641,2	701,6
①	SEER (EN 14825)		4,64	4,59	4,55	4,65	4,6	4,55	4,64	4,57
②	η _{s,c}	%	183	181	179	183	181	179	183	180

- ① Low temperature application (7°C)
- ② Seasonal energy efficiency: low temperature cooling (EU Regulation 2016/2281)

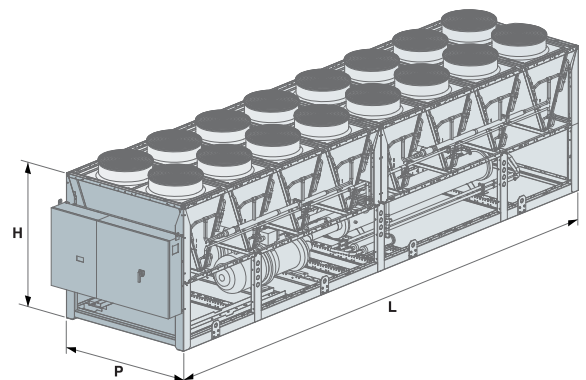

TCAVBZ MODEL		2755	2805	2865	2935	2995	21075	21115	21275
① Nominal cooling capacity	kW	751,1	797,5	857,9	930,2	985,7	1072,1	1110,7	1271
① E.E.R.		2,89	3	2,9	2,98	2,92	3,06	2,94	3,06
① Absorbed power	kW	259,9	265,8	295,8	312,1	337,6	350,4	377,8	415,4
TCAVBZ MODEL		2755	2805	2865	2935	2995	21075	21115	21275
② Sound pressure	dB(A)	67,5	67,5	68	68	68	69	69	69
③ Sound power	dB(A)	100	100	101	101	101	102	102	102
Screw/step compressor	n.	2/ REGOLAZIONE CONTINUA LINEARE (25-100%)							
Circuits	n.	2	2	2	2	2	2	2	2
Electrical supply	V-ph-Hz	400-3-50	400-3-50	400-3-50	400-3-50	400-3-50	400-3-50	400-3-50	400-3-50
DIMENSIONS AND WEIGHTS		2755	2805	2865	2935	2995	21075	21115	21275
L - Width	mm	5990	7150	7150	8250	8250	9350	9350	10450
H - Height	mm	2450	2450	2450	2450	2450	2450	2450	2450
P - Depth	mm	2260	2260	2260	2260	2260	2260	2260	2260
④ TCAVBZ weight	kg	4290	5280	5700	6070	6130	6620	6640	7000

Data at the following conditions:

- ① Air: 35°C - Water: 12/7°C.
- ② In open field (Q = 2) at 10 m from the unit.
- ③ Total sound power level in dB(A) based on measurements carried out in accordance with regulation UNI EN-ISO 9614.
- ④ Weight referred to the unit without load and not accessorised.

Performance according to EN 14511.

SEASONAL ENERGY PERFORMANCE		2755	2805	2865	2935	2995	21075	21115	21275
TCAVBZ MODEL SEASONAL PERFORMANCE IN COOLING MODE									
① P _{design,c} (EN 14825)	kW	751,1	797,5	857,9	930,2	985,7	1072,1	1110,7	1271
① SEER (EN 14825)		4,56	4,57	4,57	4,58	4,55	4,58	4,57	4,65
② η _{s,c}	%	179	180	180	180	179	180	180	183

- ① Low temperature application (7°C)
- ② Seasonal energy efficiency: low temperature cooling (EU Regulation 2016/2281)

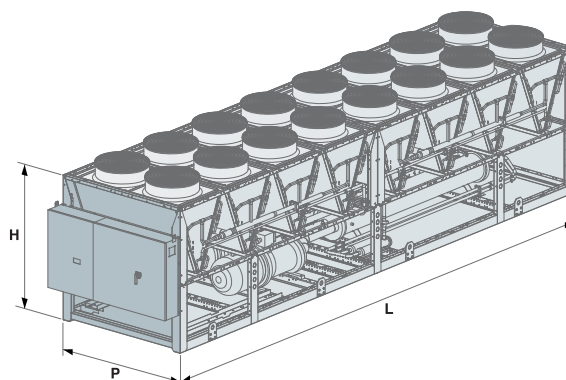

Z-Power SE

TCAVZ 21400÷21600

Cooling capacity: 1404.4-1,609.7 kW



TCAVSZ 21600 with DS accessory and pump unit

- Installation flexibility up to 1,600 kW
- Standard electronic expansion valve
- Integrated MASTER/SLAVE control

Air cooled water chillers with axial fans.
Range with semi-hermetic screw compressors and R134a refrigerant gas.

Construction features

- Compressor: high energy efficiency semi-hermetic screw compressor, with star-delta limited start and complete with integral protection, casing heater and refrigerant gas outlet piping shut-off valve.
- Electronic expansion valve: as standard on all models.
- Water side heat exchanger: dry expansion shell and tube exchanger with counterflow heat exchange, complete with closed cell polyurethane foam rubber insulation, water flow differential pressure switch and Victaulic fittings.
- Air side heat exchanger: finned coil with copper pipes and aluminium fins.
- Fan: external rotor axial type electric fans equipped with internal thermal protection, protection grilles and proportional electronic device for continuous fan rotation speed adjustment.
- Control: microprocessor electronic control.
- Structure: made of galvanised and painted steel plate with polyester powder coating.
- The unit is also complete with:
 - display of cooling circuit high/low pressure;
 - Master/Slave control up to 4 units in parallel;
 - clock board;
 - control of Variable Primary Flow (VPF_R).

Versions

- B - Standard version (TCAVBZ).
- I - Soundproofed version with soundproofing lining of the compressors (TCAVIZ).

Models

- TCAVBZ: unit designed for cooling only.
- TCAVIZ: soundproofed unit designed for cooling only.

Factory fitted accessories

- Desuperheater.
- 100% heat recovery unit.
- Thermostat with display for heat recovery unit/desuperheater.
- Condensing control with fans with EC motor.
- Power factor correction capacitors ($\cos\phi > 0.94$).
- Compressor and fan circuit breaker switches.
- Forced limit of power consumption.
- Inlet compressor shut-off valves.
- Low and high pressure gauges for each cooling circuit.
- Bottom compartment protection nets.
- Coil protection nets.
- Compressors with linear capacity control (25-100 %).
- Evaporator antifreeze resistance and heat exchangers for heat recovery if present.
- Digital input for double set-point.
- Compressor oil level sensor.
- Control of min/max power supply voltage.
- 4-20 mA analogue input for shifting set-point.
- Low temperature water production.
- Pre-painted copper/aluminium or copper/copper coils.
- Interfaces for serial communication with other devices.
- Spring anti-vibration mounts.

Separately supplied accessories

- Remote keypad with display.
- Rhoss supervisors for unit monitoring and remote management.
- Rhoss sequencer for integrated management of multiple chillers.



TCAVBZ-TCAVIZ MODEL		21400	21500	21600
① Nominal cooling capacity	kW	1404,4	1497,6	1609,7
① E.E.R.		3,1	3,1	3,1
① Absorbed power	kW	453,03	483,1	519,26
② Sound pressure	dB(A)	70	71	71
③ Sound power	dB(A)	103	104	104
Screw/step compressor	n.	2/6	2/6	2/6
Circuits	n.	2	2	2
Electrical supply	V-ph-Hz	400-3-50	400-3-50	400-3-50
DIMENSIONS AND WEIGHTS		21400	21500	21600
L - Width	mm	10.980	12.980	12.980
H - Height	mm	2.430	2.430	2.430
P - Depth	mm	2.260	2.260	2.260
④ TCAVBZ weight	kg	9310	10220	10460
④ TCAVIZ weight	kg	9660	10540	10780

Data at the following conditions:

- ① Air: 35°C - Water: 12/7°C.
- ② In open field (Q = 2) at 10 m from the unit.
- ③ Total sound power level in dB(A) based on measurements carried out in accordance with regulation UNI EN-ISO 9614.
- ④ Weight without load refers to the unit accessorised with RPE - KRP.

Performance according to EN 14511.

SEASONAL ENERGY PERFORMANCE		21400	21500	21600
TCAVBZ-TCAVIZ MODEL SEASONAL PERFORMANCE IN COOLING MODE				
① P _{design,c} (EN 14825)	kW	1404,4	1497,6	1609,7
① SEER (EN 14825)		4,56	4,6	4,59
② $\eta_{s,c}$	%	179	181	180

- ① Low temperature application (7°C)
- ② Seasonal energy efficiency: low temperature cooling (EU Regulation 2016/2281)

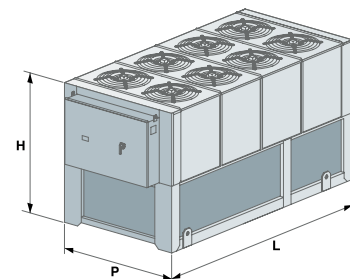

Z-Power FREECOOLING

TFAVBZ - TFAVIZ - TFAVSZ 2420÷21100

Cooling capacity: 469-1,216 kW



TFAVBZ 2500
with FMB accessory

- High efficiency
- Standard electronic expansion valve
- Extended operation limits

Air cooled water chillers in Freecooling mode with axial fans. Range with semi-hermetic screw compressors and R134a refrigerant gas.

Construction features

- Compressor: high energy efficiency semi-hermetic screw compressor, with star-delta limited start and complete with integral protection, casing heater and refrigerant gas outlet piping shut-off valve.
- 2 circuits/ 6 capacity steps.
- Water side heat exchanger: counterflow dry expansion shell and tube type, complete with: differential pressure switch, air vent valve, water drain cock, closed cell polyurethane foam rubber insulation with protection film against UVA rays. Victaulic connections.
- Air side heat exchanger: consisting of coil made of copper pipes and aluminium fins divided into two sections: one dedicated to the condensation of the refrigerant gas and one dedicated to cooling the water in free-cooling mode.
- 3-way modulating valve to divert the water flow from the system towards the free-cooling coil or directly towards the evaporator.
- Fan: external rotor axial type electric fans, equipped with internal thermal protection, accident protection grilles and a proportional electronic device for pressurised and continuous fan rotation speed regulation up to an outdoor air temperature of -15°C.
- Control: electronic microprocessor control prepared for the connection with the main BMS available on the market (MODBUS RTU, LON, BacNet).
- Structure: load-bearing structure made of galvanised and painted steel plate with polyester powder coating. The unit is also complete with:
 - display of cooling circuit high and low pressure;
 - clock board

Versions

- B - High efficiency standard version (TFAVBZ).
- I - Soundproofed version with soundproofing lining on the compressor compartment (TFAVIZ).
- S - Silenced version with soundproofing lining on the compressor compartment and reduced speed fans (TFAVSZ).

Models

- TFAVBZ: high efficiency base unit in Freecooling mode.
- TFAVIZ: soundproofed unit in Freecooling mode.
- TFAVSZ: silenced unit in Freecooling mode.

Factory fitted accessories

- Condensing control -20°C with fans with EC motor.
- Power factor correction capacitors ($\cos\phi > 0.94$).
- Compressor and fan circuit breaker switches.
- Forced limit of power consumption.
- Inlet compressor shut-off valves.
- Low and high pressure gauges for each cooling circuit.
- Bottom compartment protection nets.
- Coil protection nets.
- Coil protection metal filter.
- Compressors with linear capacity control (25-100 %).
- Evaporator antifreeze heater.
- Digital input for double set-point.
- Low water temperature.
- Double high pressure safety valve with exchange valve.
- Stainless steel cooling circuit.
- Electrical panel heater.
- Soft starter.
- Compressor oil level sensor.
- Control of min/max power supply voltage.
- 4-20 mA analogue signal for shifting set-point.
- Pre-painted copper/coils or copper/copper coils.
- Interfaces for serial communication with other devices.
- Spring anti-vibration mounts.

Separately supplied accessories

- Remote keypad with display.
- Rhoss supervisors for unit monitoring and remote management.



TFAVBZ - TFAVIZ - TFAVSZ MODEL		2420	2450	2500	2560	2660	2750	
FREE-COOLING OFF								
❶	Nominal cooling capacity	kW	481	512	574	636	825	
❶	Nominal cooling capacity	kW	469	499	555	618	811	
❶	E.E.R.		3,79	3,79	3,7	3,72	3,74	
❶	E.E.R.		3,78	3,78	3,6	3,68	3,75	
❶	Absorbed power	kW	127	135	155	171	202	
❶	Absorbed power	kW	124	132	154	168	216	
FREE-COOLING ON 100%								
❷	Nominal cooling capacity	kW	481	512	574	636	825	
❷	Nominal cooling capacity	kW	469	499	555	618	811	
❷	E.E.R.		24,05	25,6	28,7	26,5	23,63	
❷	E.E.R.		37,5	39,89	44,43	41,19	36,84	
❷	Absorbed power	kW	20	20	20	24	32	
❷	Absorbed power	kW	12,5	12,5	12,5	15	20	
❷	Total Free-cooling Temperature	°C	2,4	1,8	1,1	1,8	2,3	
❷	Total Free-cooling Temperature	°C	1,2	0,5	0	0,8	1,1	
TFAVBZ - TFAVSZ MODEL			2420	2450	2500	2560	2660	2750
❸	Sound pressure	dB(A)	65	65	65	66	68	68
❸	Sound pressure	dB(A)	60	60	60	60	62	62
❹	Sound power	dB(A)	98	98	98	99	101	101
❹	Sound power	dB(A)	92	92	92	93	95	95
	Scroll/step compressor	n.	2/6	2/6	2/6	2/6	2/6	2/6
	Circuits	n.	2	2	2	2	2	2
	Electrical supply	V-ph-Hz	400-3-50	400-3-50	400-3-50	400-3-50	400-3-50	400-3-50
DIMENSIONS AND WEIGHTS			2420	2450	2500	2560	2660	2750
	L - Width	mm	6130	6130	6130	7160	10080	10080
	H - Height	mm	2580	2580	2580	2580	2580	2580
	P - Depth	mm	2260	2260	2260	2260	2260	2260
❺	TFAVBZ weight	kg	4850	5700	5780	6470	8180	8280
❺	TFAVIZ - TFAVSZ weight	kg	5090	6000	6080	6770	8560	8660

Data at the following conditions:

- ❶ Air: 30°C - Water: 15/10°C - Ethylene glycol 30%.
 - ❷ Water: 15/10°C - Ethylene glycol 30%.
 - ❸ In open field (Q = 2) at 10 m from the unit on the coil side.
 - ❹ Total sound power level in dB(A) based on measurements carried out in accordance with regulation UNI EN-ISO 9614.
 - ❺ Weight referred to the unit without load and not accessorised.
- ☐ TFAVSZ silenced version.

SEASONAL ENERGY PERFORMANCE		2420	2450	2500	2560	2660	2750	
TFAVBZ - TFAVIZ MODEL SEASONAL PERFORMANCE IN COOLING MODE								
❺	PdesignR	kW	419,8	447,6	501,5	554,3	658,9	745,2
❺	SEPR		5,59	5,59	5,57	5,57	5,6	5,61
TFAVSZ MODEL SEASONAL PERFORMANCE IN COOLING MODE								
❺	PdesignR	kW	408,8	435,9	484,8	538,7	641,9	731,1
❺	SEPR		5,64	5,64	5,62	5,65	5,63	5,63

- ❺ Application for high temperature (7°C) process chiller (EU Regulation 2016/2281)

Z-Power FREECOOLING

TFAVBZ - TFAVIZ - TFAVSZ 2420÷21100

TFAVBZ - TFAVIZ - TFAVSZ MODEL		2800	2850	2920	2990	21050	21100
FREE-COOLING OFF							
① Nominal cooling capacity	kW	885	944	1019	1093	1155	1216
① Nominal cooling capacity	kW	867	922	1000	1071	1129	1186
① E.E.R.		3,71	3,66	3,69	3,72	3,68	3,64
① E.E.R.		3,66	3,57	3,68	3,69	3,61	3,55
① Absorbed power	kW	238,5	258	276	294	314	334
① Absorbed power	kW	237	258	272	290	313	334
FREE-COOLING ON 100%							
② Nominal cooling capacity	kW	885	944	1019	1093	1155	1216
② Nominal cooling capacity	kW	867	922	1000	1071	1129	1186
② E.E.R.		27,66	29,5	25,48	27,33	28,88	30,4
② E.E.R.		43,36	46,12	39,99	42,84	45,15	47,44
② Absorbed power	kW	32	32	40	40	40	40
② Absorbed power	kW	20	20	25	25	25	25
② Total Free-cooling Temperature	°C	1,2	0,6	1,1	1,6	1,1	0,5
② Total Free-cooling Temperature	°C	0	-0,7	0	0,3	-0,5	-1
TFAVBZ - TFAVSZ MODEL		2800	2850	2920	2990	21050	21100
③ Sound pressure	dB(A)	68	68	69	69	69	69
③ Sound pressure	dB(A)	62	62	63	63	63	63
④ Sound power	dB(A)	101	101	102	102	102	102
④ Sound power	dB(A)	95	95	96	96	96	96
Scroll/step compressor	n.	2/6	2/6	2/6	2/6	2/6	2/6
Circuits	n.	2	2	2	2	2	2
Electrical supply	V-ph-Hz	400-3-50	400-3-50	400-3-50	400-3-50	400-3-50	400-3-50
DIMENSIONS AND WEIGHTS		2800	2850	2920	2990	21050	21100
L - Width	mm	10080	10080	12080	12080	12080	12080
H - Height	mm	2580	2580	2580	2580	2580	2580
P - Depth	mm	2260	2260	2260	2260	2260	2260
⑤ TFAVBZ weight	kg	8740	9155	10245	10255	10580	10640
⑤ TFAVIZ - TFAVSZ weight	kg	9120	9535	10625	10635	10960	11020

Data at the following conditions:

- ① Air: 30°C - Water: 15/10°C - Ethylene glycol 30%.
- ② Water: 15/10°C - Ethylene glycol 30%.
- ③ In open field (Q = 2) at 10 m from the unit on the coil side.
- ④ Total sound power level in dB(A) based on measurements carried out in accordance with regulation UNI EN-ISO 9614.
- ⑤ Weight referred to the unit without load and not accessorised.

☐ TFAVSZ silenced version.

SEASONAL ENERGY PERFORMANCE		2800	2850	2920	2990	21050	21100
TFAVBZ - TFAVIZ MODEL SEASONAL PERFORMANCE IN COOLING MODE							
⑤ PdesignR	kW	796,8	847	917,5	983,2	1038,8	1092,7
⑤ SEPR		5,56	5,54	5,6	5,61	5,61	5,58
TFAVSZ MODEL SEASONAL PERFORMANCE IN COOLING MODE							
⑤ PdesignR	kW	779	825,5	898,2	961,1	1013,1	1063,4
⑤ SEPR		5,61	5,6	5,65	5,63	5,68	5,6

- ⑤ Application for high temperature (7°C) process chiller (EU Regulation 2016/2281)



TurboPOWER

TCATBZ-TCATTZ 1300÷31100 / TCATQZ 1300÷3990

Cooling capacity: 267.0-1101 kW



TCATTZ 31100 with
FIAP accessory

TCATBZ 1400 with PTL-RPE-
FIAP accessories

- Efficient, quiet and low start-up current oil-free compressor
- High energy efficiency chillers.
- Wide range of accessories
- Integrated MASTER/SLAVE control

Air cooled water chillers with axial fans.
Range with oil-free centrifugal compressors and R134a refrigerant gas.

Construction features

- Compressor: high energy efficiency, oil free, centrifugal compressor with limited start, equipped with magnetic levitation bearings and complete with integral protection and intake and delivery shut-off valves.
- Water side heat exchanger: flooded type shell and tube, complete with closed cell polyurethane foam rubber insulation, water flow differential pressure switch and Victaulic fittings.
- Air side heat exchanger: with micro-channels.
- Fan: external rotor axial type electric fans with internal thermal protection, accident protection grilles. Version B is equipped with a proportional electronic device for continuous fan rotation speed regulation, while versions T-Q are equipped with EC motor fans.
- Control: microprocessor electronic control.
- Structure: made of galvanised and painted steel plate with polyester powder coating.
- The unit is also complete with:
 - display of cooling circuit high/low pressure;
 - electronic expansion valve;
 - double safety valve;
 - clock board;
 - Master/Slave control up to 4 units in parallel;
 - control of Variable Primary Flow (VPF_R).

Versions

- B - Basic version, soundproofed technical compressor compartment (TCATBZ).
- T - High-efficiency version, soundproofed technical compressor compartment (TCATTZ).
- Q - Super silenced version, super-soundproofed technical compartment, reduced speed fans (TCATQZ).

Models

- TCATBZ: standard unit designed for cooling only.
- TCATTZ: high efficiency unit designed for cooling only.
- TCATQZ: super silenced unit designed for cooling only.

Factory fitted accessories

- PUMP with single or double electric pump, one of which automatic in standby. The electric pumps are available in the low or high head versions.
- Inverter pump control for unit start-up.
- Condensing control with fans with EC motor (standard in T-Q versions).
- Condensing control with over-pressure fans.
- Power factor correction capacitors ($\cos\phi > 0.94$).
- Compressor circuit breaker switches.
- Electro-mechanical flow switch.
- Forced limit of power consumption.
- Forced noise limit.
- Energy parameter measuring device.
- Soundproofed compressor box.
- Refrigerant leak detector.
- Cooling circuit high and low pressure gauges.
- Coil protection nets.
- Micro-channel coils with E-coating treatment.
- Control of min/max power supply voltage.
- Digital input for double set-point.
- 4-20 mA analogue signal for shifting set-point.
- Evaporator antifreeze heater, electrical panel, electric pumps, if applicable.
- Interfaces for serial communication with other devices.
- Anti-vibration mounts.

Separately supplied accessories

- Remote keypad with display.
- Rhoss supervisors for unit monitoring and remote management.
- Rhoss sequencer for integrated management of multiple chillers.



TCATBZ-TCATTZ-TCATQZ MODEL		1300	1400	2500	2590	2680	2760	2820	2880	3990	31100
① TCATBZ nominal cooling capacity	kW	284,9	376,6	489,2	577,8	675,1	749,2	808,9	874,4	982,2	1089,1
① TCATTZ nominal cooling capacity	kW	298,8	402,3	498,1	593,6	685	760	820,8	882,3	993,1	1101
① TCATQZ nominal cooling capacity	kW	267,1	369,7	463,4	541,2	639,5	721,5	792,1	871,6	970,4	-
① E.E.R. TCATBZ		3,2	3,18	3,26	3,22	3,2	3,2	3,22	3,14	3,25	3,22
① E.E.R. TCATTZ		3,46	3,42	3,46	3,48	3,37	3,52	3,5	3,33	3,47	3,45
① E.E.R. TCATQZ		3,22	3,32	3,25	3,28	3,21	3,24	3,36	3,31	3,27	-
① TCATBZ absorbed power	kW	89	118,4	150,1	179,4	211	234,1	251,2	278,5	302,2	338,2
① TCATTZ absorbed power	kW	86,4	117,6	144	170,6	203,3	215,9	234,5	265	286,2	319,1
① TCATQZ absorbed power	kW	83	111,4	142,6	165	199,2	222,7	235,7	263,3	296,8	-
TCATBZ-TCATTZ-TCATQZ MODEL		1300	1400	2500	2590	2680	2760	2820	2880	3990	31100
② TCATBZ sound pressure	dB(A)	60	62	62,5	62,5	63	64	64	64	64	65
② TCATTZ sound pressure	dB(A)	60	62	62,5	62,5	63	64	64	64	64	65
② TCATQZ sound pressure	dB(A)	55	56	56,5	57	58	58	58	59	59	-
③ TCATBZ sound power	dB(A)	92	94	95	95	96	97	97	97	97	98
③ TCATTZ sound power	dB(A)	92	94	95	95	96	97	97	97	97	98
③ TCATQZ sound power	dB(A)	87	88	89	90	91	91	91	92	92	-
Compressor/steps	n.	1/REGOLAZIONE CONTINUA	1/REGOLAZIONE CONTINUA	2/REGOLAZIONE CONTINUA	2/REGOLAZIONE CONTINUA	2/REGOLAZIONE CONTINUA	2/REGOLAZIONE CONTINUA	2/REGOLAZIONE CONTINUA	2/REGOLAZIONE CONTINUA	3/REGOLAZIONE CONTINUA	3/REGOLAZIONE CONTINUA
Circuits	n.	1	1	1	1	1	1	1	1	2	2
Electrical supply	V-ph-Hz	400-3-50	400-3-50	400-3-50	400-3-50	400-3-50	400-3-50	400-3-50	400-3-50	400-3-50	400-3-50
DIMENSIONS AND WEIGHT		1300	1400	2500	2590	2680	2760	2820	2880	3990	31100
W - Width of version B	mm	3840	4940	6090	7250	8350	9450	9450	10550	11650	12810
W - Width of version T	mm	3840	4940	6090	7250	8350	9450	10550	11650	11650	12810
W - Width of version Q	mm	3840	4940	6090	7250	8350	9450	10550	11650	12810	-
H - Height	mm	2450	2450	2450	2450	2450	2450	2450	2450	2450	2450
P - Depth	mm	2260	2260	2260	2260	2260	2260	2260	2260	2260	2260
④ TCATBZ weight	kg	2390	2740	3490	3950	4350	4800	4910	5210	6040	6560
④ TCATTZ weight	kg	2410	2760	3470	3980	4320	4840	5140	5440	6000	6520
④ TCATQZ weight	kg	2390	2730	3500	3960	4350	4800	5160	5460	6500	-

Data at the following conditions:

- ① Air: 35°C - Water: 12/7°C
- ② In open field (Q = 2) at 10 m from the unit.
- ③ Total sound power level in dB(A) based on measurements carried out in accordance with regulation UNI EN-ISO 9614.
- ④ Weight referred to the unit without load and not accessorised.

■ TCATQZ super silenced versions

Performance according to EN 14511.

SEASONAL ENERGY PERFORMANCE		1300	1400	2500	2590	2680	2760	2820	2880	3990	31100
TCATBZ MODEL SEASONAL PERFORMANCE IN COOLING MODE											
① P _{designc} (EN 14825)	kW	284,9	376,6	489,2	577,8	675,1	749,2	808,8	874,4	982,1	1088,9
① SEER (EN 14825)		5,3	5,18	5,34	5,26	5,35	5,21	5,26	5,21	5,35	5,31
② $\eta_{s,c}$	%	209	204	211	207	211	205	207	205	211	210
TCATTZ MODEL SEASONAL PERFORMANCE IN COOLING MODE											
① P _{designc} (EN 14825)	kW	298,8	402,3	498,1	593,6	685	760,1	820,8	882,3	993,1	1100,9
① SEER (EN 14825)		5,63	5,75	5,85	5,83	5,91	6,03	5,97	5,94	5,99	5,94
② $\eta_{s,c}$	%	222	227	231	230	234	238	236	235	237	234
TCATQZ MODEL SEASONAL PERFORMANCE IN COOLING MODE											
① P _{designc} (EN 14825)	kW	267,1	369,7	463,4	541,2	639,5	721,5	792,1	871,6	970,3	-
① SEER (EN 14825)		5,65	5,76	5,88	5,81	5,9	5,96	5,98	5,98	6,02	-
② $\eta_{s,c}$	%	223	227	232	230	233	235	236	236	238	-

- ① Low temperature application (7°C)
- ② Seasonal energy efficiency: low temperature cooling (EU Regulation 2016/2281)

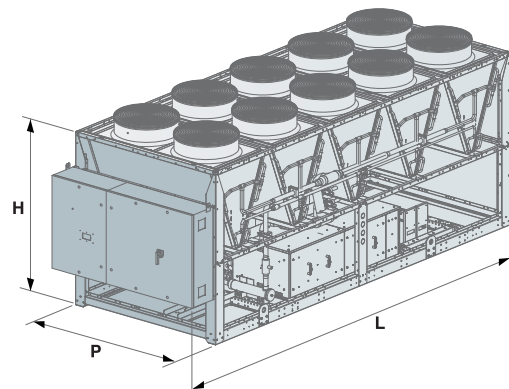

TurboPOWER ECO

TCATTE-TCATQE 1330÷3950

Cooling capacity: 323.2-948.6 kW



TCATTE 3950 with FIAP accessory

TCATTE 1330 with PTL-RPE-FIAP accessories

- High energy efficiency chillers
- Efficient, quiet and low start-up current oil-free compressor
- HFO R1234ze ecological gas
- Integrated MASTER/SLAVE control

Air cooled water chillers with axial fans.

Range with oil-free centrifugal compressors and R1234ze refrigerant gas.

Construction features

- Compressor: high energy efficiency, oil free, centrifugal compressor with limited start, equipped with magnetic levitation bearings and complete with integral protection and intake and delivery shut-off valves. The compressor was specifically designed for R1234ze gas with zero environmental impact.
- Water side heat exchanger: spray flooded type shell and tube exchanger, complete with closed cell polyurethane foam rubber insulation, water flow differential pressure switch and Victaulic fittings.
- Air side heat exchanger: with micro-channels.
- Fan: external rotor helical type EC motor electric fans with internal thermal protection and accident protection grilles.
- Control: microprocessor electronic control.
- Structure: made of galvanised and painted steel plate with polyester powder coating.
- The unit is also complete with:
 - display of cooling circuit high/low pressure;
 - electronic expansion valve;
 - double safety valve;
 - leak detector;
 - clock board;
 - Master/Slave control up to 4 units in parallel;
 - control of Variable Primary Flow (VPF_R).

Versions

- T - High-efficiency version, soundproofed technical compressor compartment (TCATTE).
- Q - Super silenced version, super-soundproofed technical compartment, reduced speed fans (TCATQE).

Models

- TCATTE: high efficiency unit designed for cooling only.
- TCATQE: super silenced unit designed for cooling only.

Factory fitted accessories

- PUMP with single or double electric pump, one of which automatic in standby. The electric pumps are available in the low or high head versions.
- Inverter pump control for unit start-up.
- Condensing control with over-pressure fans.
- Power factor correction capacitors ($\cos\phi > 0.94$).
- Compressor circuit breaker switches.
- Electro-mechanical flow switch.
- Forced limit of power consumption.
- Forced noise limit.
- Energy parameter measuring device.
- Soundproofed compressor box.
- Cooling circuit high and low pressure gauges.
- Coil protection nets.
- Micro-channel coils with E-coating treatment.
- Control of min/max power supply voltage.
- Digital input for double set-point.
- 4-20 mA analogue signal for shifting set-point.
- Evaporator antifreeze heater, electrical panel, electric pumps, if applicable.
- Interfaces for serial communication with other devices.
- Anti-vibration mounts.

Separately supplied accessories

- Remote keypad with display.
- Rhoss supervisors for unit monitoring and remote management.
- Rhoss sequencer for integrated management of multiple chillers.



TCATTE-TCATQE MODEL		1330	2400	2470	2550	2660	3790	3950	
❶	Nominal cooling capacity	kW	334,2	399,1	470	548,9	660,5	792,1	948,6
❶	Nominal cooling capacity	kW	323,2	386,1	450,1	536,9	639,7	767,3	916,9
❶	E.E.R.		3,45	3,44	3,5	3,45	3,4	3,49	3,46
❶	E.E.R.		3,45	3,39	3,46	3,37	3,38	3,45	3,43
❶	Absorbed power	kW	96,9	116	134,3	159,1	194,3	227	274,2
❶	Absorbed power	kW	93,7	113,9	130,1	159,3	189,3	222,4	267,3
TCATTE-TCATQE MODEL		1330	2400	2470	2550	2660	3790	3950	
❸	TCATTE sound pressure	dB(A)	62	62,5	62,5	63	64	64	65
❸	TCATQE sound pressure	dB(A)	56	56,5	57	58	58	59	60
❹	TCATTE sound power	dB(A)	94	95	95	96	97	97	98
❹	TCATQE sound power	dB(A)	88	89	90	91	91	92	93
			1/	2/	2/	2/	2/	3/	3/
	Compressor/steps	n.	REGOLAZIONE CONTINUA	REGOLAZIONE CONTINUA	REGOLAZIONE CONTINUA	REGOLAZIONE CONTINUA	REGOLAZIONE CONTINUA	REGOLAZIONE CONTINUA	REGOLAZIONE CONTINUA
	Circuits	n.	1	1	1	1	1	2	2
	Electrical supply	V-ph-Hz	400-3-50	400-3-50	400-3-50	400-3-50	400-3-50	400-3-50	400-3-50
DIMENSIONS AND WEIGHTS		1330	2400	2470	2550	2660	3790	3950	
	L - Width	mm	4940	6090	7250	8350	9450	11650	12810
	H - Height	mm	2450	2450	2450	2450	2450	2450	2450
	P - Depth	mm	2260	2260	2260	2260	2260	2260	2260
❺	TCATTE weight	kg	2770	3410	3960	4270	4880	6280	6840
❺	TCATQE weight	kg	2790	3440	3990	4300	4910	6310	6880

Data at the following conditions:

- ❶ Air: 35°C - Water: 12/7°C
 - ❸ In open field (Q = 2) at 10 m from the unit.
 - ❹ Total sound power level in dB(A) based on measurements carried out in accordance with regulation UNI EN-ISO 9614.
 - ❺ Weight referred to the unit without load and not accessorised.
- TCATQE super silenced versions
Performance according to EN 14511.

SEASONAL ENERGY PERFORMANCE		1330	2400	2470	2550	2660	3790	3950	
TCATTE MODEL SEASONAL PERFORMANCE IN COOLING MODE									
❶	P _{design,c} (EN 14825)	kW	334,2	399,1	470	548,9	660,5	792	948,6
❶	SEER (EN 14825)		5,73	5,77	5,77	5,82	5,83	6,01	6
❷	η _{s,c}	%	226	228	228	230	230	238	237
TCATQE MODEL SEASONAL PERFORMANCE IN COOLING MODE									
❶	P _{design,c} (EN 14825)	kW	323,2	386,1	450,1	536,9	639,7	767,2	916,8
❶	SEER (EN 14825)		5,74	5,79	5,84	5,83	5,88	6,06	5,98
❷	η _{s,c}	%	226	229	231	230	232	239	236

- ❶ Low temperature application (7°C)
- ❷ Seasonal energy efficiency: low temperature cooling (EU Regulation 2016/2281)

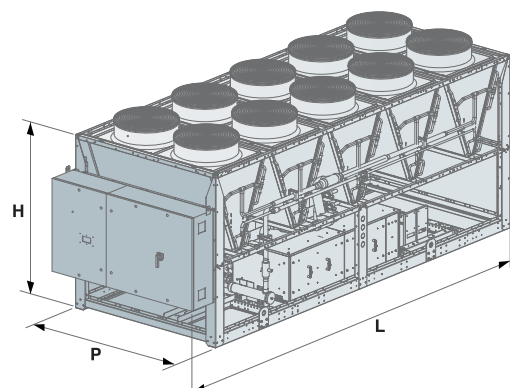



CHILLERS - HEAT PUMPS

Air cooled - Centrifugal fans

Compact-ID

TCCITY-THCITY 117÷128

Cooling capacity: 16.4-27.5 kW - Heating capacity: 17.7-28.5 kW

INVERTER



- **PLUG-FANS with low consumption EC motor**
- **Vertically or horizontally ducted delivery.**
- **Hot water up to -15°C outdoor air**
- **Temperature of the produced water up to 60°C**
- **Integrated MASTER/SLAVE control**
- **Inertial buffer tank**



Packaged air-cooled water chillers and reversible heat pumps with Plug-Fans with EC motor. Range with scroll hermetic compressors, DC Inverter and R410A refrigerant gas.

- Compressor: scroll type, rotary, hermetic with Inverter actuation, complete with thermal protection and casing heater.
- Water side heat exchanger: adequately insulated stainless steel plates, complete with antifreeze heater and water flow differential pressure switch.
- Air side heat exchanger: featuring a finned coil with copper pipes and aluminium fins for TCCITY and with hydrophilic treatment for THCITY, complete with protection grilles.
- Fan: Plenum electric fan with directly coupled, low consumption EC motor fitted with internal thermal protection and accident protection grilles. Removable fan unit section for on-site positioning.
- Vertical condensing air delivery, horizontal outlet easily transformed on-site.
- Proportional electronic device for the continuous regulation of the fan rotation speed up to a temperature of outdoor air of -10°C when running as a chiller.
- Control: microprocessor electronic control with Adaptive Function Plus logic.
- Structure: made of galvanised and painted steel plate, complete with condensate drain pan and unit base antifreeze heater for THCITY.
- The unit is also complete with:
 - outdoor air temperature probe for set-point compensation;
 - electronic expansion valve;
 - display of cooling circuit high and low pressure;
 - Master/Slave control up to 4 units in parallel;
 - clock board.

Version

T - High efficiency.

Models

TCCITY: unit designed for cooling only.
THCITY: heat pump unit.

PUMP set-up

- Pump unit complete with: EC circulator with 3 speed selector or continuous speed regulation or electric pump, membrane expansion tank, manual air vent valve, safety valve and pressure gauge.

TANK&PUMP set up

- Pump unit complete with: inertial buffer tank, circulator or electric circulation pump, membrane expansion tank, manual air vent valve, safety valve, and pressure gauge.

Factory fitted accessories

- Forced Download. Compressor partialisation or switch-off to limit power and current consumption (digital input).
- Antifreeze heater on the tank.
- Circulator/electric pump antifreeze heater.
- Pre-painted copper/coils or copper/copper coils.
- Digital input for double set-point.
- 4-20 mA analogue signal for shifting set-point.

Accessories supplied loose

- 3-way valve for the production of domestic hot water, managed by regulation.
- Additional electrical resistance for heat pump, managed by regulation.
- Remotely controllable outdoor air temperature probe for set-point compensation.
- Delivery anti-vibration fitting.
- Suction duct fitting.
- Water filter.
- Rubber anti-vibration mounts.
- Remote keypad with display.
- Interfaces for serial communication with other devices.
- RS485/USB serial converter.
- Rhoss supervisors for unit monitoring and remote management.



TCCITY MODEL		117	124	128
① MIN/NOM/MAX cooling capacity	kW	16,4	24,3	27,5
① NOM absorbed power	kW	5,24	8,15	9,01
① E.E.R. NOM		3,13	2,98	3,05
THCITY MODEL		117	124	128
② MIN/NOM/MAX heating capacity	kW	17,7	24,3	28,5
② NOM absorbed power	kW	5,33	7,48	8,88
② C.O.P. NOM		3,32	3,25	3,21
③ MIN/NOM/MAX heating capacity	kW	18,8	25	29,1
③ NOM absorbed power	kW	4,59	6,1	7,28
③ C.O.P. NOM		4,1	4,1	4
④ MIN/NOM/MAX heating capacity	kW	12,3	18,1	22,9
④ NOM absorbed power	kW	4,14	6,65	7,46
④ C.O.P. NOM		2,97	2,72	3,07
① MIN/NOM/MAX cooling capacity		16,2	23,8	27
① E.E.R. NOM		2,98	2,84	2,91
TCCITY - THCITY MODEL		117	124	128
⑤ Fan delivery sound pressure	dB(A)	53	53	56
⑤ Machine body sound pressure	dB(A)	42	42	45
Fan nominal air flow	m ³ /h	7600	7600	8640
Fan available static pressure	Pa	80	80	80
① PO circulator available head	kPa	89	89	76
Buffer tank water content	l	110	110	110
Electrical supply	V-ph-Hz	400-3+N-50	400-3+N-50	400-3+N-50
DIMENSIONS AND WEIGHT		117	124	128
L - PUMP width	mm	1522	1522	1522
L - TANK&PUMP width	mm	1625	1625	1625
H - PUMP height	mm	1280	1280	1280
H - TANK&PUMP height	mm	1590	1590	1590
P - PUMP Depth	mm	815	815	815
P - TANK&PUMP Depth	mm	815	815	815
⑥ PUMP Weight	kg	275	285	295
⑥ TANK&PUMP Weight	kg	445	455	465

Data at the following conditions:

- ① Air: 35°C D.B. - Water: 12/7°C.
- ② Air: 7°C D.B. - 6°C W.B. - Water: 40/45°C.
- ③ Air: 7°C D.B. - 6°C W.B. - Water: 30/35°C.
- ④ Air: -7°C D.B. - Water: 30/35°C.
- ⑤ In open field (Q = 2) at 5 m from the unit and ducted fan.
- ⑥ Weight refers to the most complete setup.

Performance according to EN 14511. PO/PIO setup.

SEASONAL ENERGY PERFORMANCE		117	124	128
TCCITY MODEL SEASONAL PERFORMANCE IN COOLING MODE				
① Pdesignc (EN 14825)	kW	16,4	24,3	27,5
① SEER (EN 14825)		4,54	4,52	4,59
② $\eta_{s,c}$	%	179	178	181
THCITY MODEL SEASONAL PERFORMANCE IN HEATING MODE				
③ Pdesignh (EN 14825)	kW	19	28	35
③ SCOP (EN 14825)		4,14	3,53	3,69
④ η_s	%	162	138	145
④ Energy class		A++	A+	A+

- ① Low temperature application (7°C)
- ② Seasonal energy efficiency: low temperature cooling (EU Regulation 2016/2281)
- ③ In Average climatic conditions, low temperature application (35°C)
- ④ Seasonal energy efficiency: low temperature heating in Average climate (EU Regulations No.811/2013 and No.813/2013)

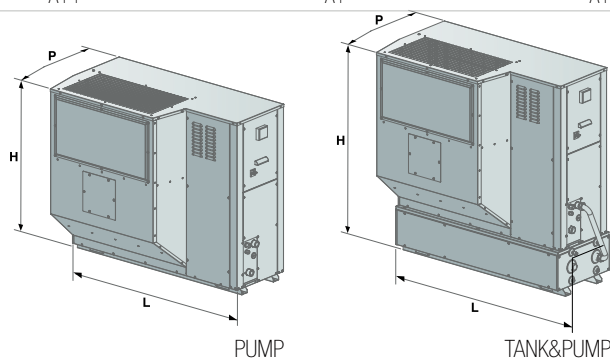

Y-Pack C-PF

TCCETY-THCETY 233÷2160

Cooling capacity: 32.3-160.2 kW - Heating capacity: 37.7-175.6 kW



- High energy efficiency range
- “Plug-Fan” type centrifugal fans with EC motor (brushless)
- Multi-purpose for systems with 2 pipes + DHW (with optional RC100)
- Integrated MASTER/SLAVE control



TCCETY 2130

THCETY 270

High efficiency air cooled water chillers and packaged reversible heat pumps with plug-fan type centrifugal fans with EC motors.

Range with scroll hermetic compressors and R410A refrigerant.

Construction features

- Compressor: scroll type, rotary, hermetic complete with thermal protection and casing heater.
 - 2 or 3 capacity steps depending on the models, to obtain excellent load modulation along with high energy efficiency at partial loads.
- Water side heat exchanger: with stainless steel plates, complete with closed cell polyurethane foam rubber insulation and water flow differential pressure switch.
- Air side heat exchanger: featuring finned coil with copper pipes and aluminium fins.
 - Plug-Fan type centrifugal electric fans with EC motors, equipped with internal thermal protection arranged in single row with horizontal outlet.
- Horizontal outlet of the evaporation condensing air opposite side to finned coil or vertical outlet can be easily transformed on site.
- Proportional electronic device for continuous fan rotation speed regulation up to an outdoor air temperature of -15°C in chiller mode and up to an outdoor air temperature of 40°C in heat pump mode.
 - Control: microprocessor electronic control with Adaptive Function Plus logic.
 - Load-bearing structure and panelling made of painted and galvanised sheet steel (RAL 9018); galvanised sheet steel base
 - The unit is also complete with:
 - fan and compressor circuit breaker switches;
 - display of cooling circuit high and low pressure;
 - Master/Slave control up to 4 units in parallel;
 - clock board;
 - control of Variable Primary Flow (VPF_R).

Versions

- T - High efficiency version (TCCETY-THCETY).

Models

- TCCETY: unit for cooling only.
- THCETY: reversible heat pump unit.

Factory fitted accessories

- PUMP with single or double electric pump, including an automatic actuation pump in standby, complete with expansion tank, safety valve and water side pressure gauge. The electric pumps are available in the low or high head versions.
- TANK&PUMP with integrated buffer tank and single or double electric pump, complete with expansion tank, air vent valves, safety valve and water side pressure gauge.
- Inverter pump control for unit start-up.
- Desuperheater.
- 100% heat recovery unit.
- Low temperature water production.
- Electronic expansion valve.
- Power factor correction capacitors ($\cos\phi > 0.94$).
- Forced limit of power consumption.
- Energy parameter measuring device.
- Optimised energy efficiency.
- Soft starter.
- Compressor soundproofing.
- Cooling circuit outlet and inlet valves.
- Refrigerant leak detector.
- Cooling circuit high and low pressure gauges.
- Double safety valves.
- Copper/copper or copper/pre-painted aluminium coils.
- Control of min/max power supply voltage.
- Digital input for double set-point.
- 4-20 mA analogue signal for shifting set-point.
- Evaporator antifreeze heater, buffer tank, pumps and heat exchangers for heat recovery if applicable.
- Interfaces for serial communication with other devices.
- Anti-vibration mounts.

Separately supplied accessories

- Remote keypad with display.
- Thermostat with display.
- Rhoss supervisors for unit monitoring and remote management.
- Rhoss sequencer for integrated management of multiple chillers.



TCCEY MODEL		233	238	245	250	260	265	270
❶ Nominal cooling capacity	kW	32,3	38,5	43,9	51	58,9	63,7	69,9
❶ E.E.R.		2,61	2,77	2,7	2,73	2,67	2,6	2,83
❶ Absorbed power	kW	12,38	13,9	16,26	18,55	21,98	24,5	24,53
THCEY MODEL		233	238	245	250	260	265	270
❷ Nominal heating capacity	kW	37,7	42,1	48,1	56,2	62,5	68,3	79,4
❷ C.O.P.		3	3	3,01	2,96	2,97	2,86	3,23
❷ Absorbed power in winter mode	kW	12,57	14,03	15,98	18,8	20,9	23,72	24,36
❶ Nominal cooling capacity	kW	32,3	38,5	42,3	50,3	57,8	61,6	69,1
❸ Sound power	dB(A)	82	82	83	85	85	85	85
Scroll/step compressor	n.	2/2	2/2	2/3	2/3	2/3	2/3	2/3
Circuits	no.	1	1	1	1	1	1	1
Fan nominal air flow	m³/h	13000	13000	13000	26000	26000	26000	26000
Fan maximum available static pressure	Pa	250	250	250	250	250	250	250
Electrical supply	V-ph-Hz	400-3+N-50	400-3+N-50	400-3+N-50	400-3+N-50	400-3+N-50	400-3+N-50	400-3+N-50
DIMENSIONS		233	238	245	250	260	265	270
L - Width	mm	2650	2650	2650	2650	2650	2650	3650
H - Height	mm	1920	1920	1920	1920	1920	1920	1920
P - Depth	mm	870	870	870	870	870	870	1100
❹ TCCEY weight	kg	820	820	850	885	890	890	1120
❹ THCEY weight	kg	840	840	875	910	910	910	1175

Data at the following conditions:

- ❶ Air: 35°C - Water: 12/7°C and ESP: 250 Pa.
 - ❷ Air: 7°C D.B. - 6°C W.B. - Water: 40/45°C and ESP: 250 Pa.
 - ❸ Total sound power level in dB(A) based on measurements carried out in accordance with regulation UNI EN-ISO 9614.
 - ❹ Weight referred to the unit without load and not accessorised.
- Performance according to EN 14511.

SEASONAL ENERGY PERFORMANCE		233	238	245	250	260	265	270
TCCEY MODEL SEASONAL PERFORMANCE IN COOLING MODE								
❶ P _{designc} (EN 14825)	kW	32,3	38,5	43,9	51	58,9	63,7	69,9
❶ SEER (EN 14825)		4,54	4,54	4,56	4,51	4,53	4,57	4,59
❷ η _{s,c}	%	179	178	179	177	178	180	181
THCEY MODEL SEASONAL PERFORMANCE IN HEATING MODE								
❸ P _{designh} (EN 14825)	kW	31	35	41	48	52	59	66
❸ SCOP (EN 14825)		3,52	3,27	3,86	3,52	3,46	3,57	3,71
❹ η _s	%	138	128	152	138	136	140	145
❹ Energy class		A+	A+	A++	A+	A+	A+	A+

- ❶ Low temperature application (7°C)
- ❷ Seasonal energy efficiency: low temperature cooling (EU Regulation 2016/2281)
- ❸ In Average climatic conditions, low temperature application (35°C)
- ❹ Seasonal energy efficiency: low temperature heating in Average climate (EU Regulations No.811/2013 and No.813/2013)

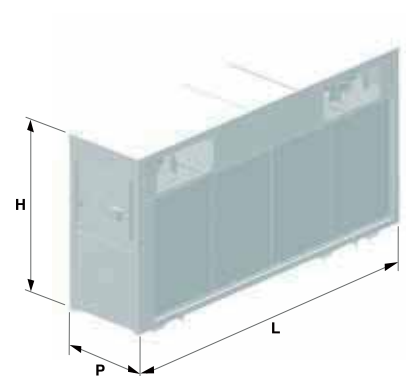

Y-Pack C-PF

TCCEY-THCEY 233÷2160

TCCEY MODEL		280	290	2100	2115	2130	2145	2160
① Nominal cooling capacity	kW	79,1	87,5	100,6	113,9	125,3	142,3	160,2
① E.E.R.		2,89	2,81	2,71	2,9	2,87	2,86	2,86
① Absorbed power	kW	27,37	31,03	36,72	38,28	43,66	49,07	55,43
THCEY MODEL		280	290	2100	2115	2130	2145	2160
② Nominal heating capacity	kW	86,3	96,4	111,5	122,5	139,6	157,6	175,6
② C.O.P.		3,36	3,18	3,16	3,21	3,3	3,21	3,2
② Absorbed power in winter mode	kW	25,53	30,31	34,95	37,69	42,3	48,49	54,2
① Nominal cooling capacity	kW	77,4	84,9	98,9	110,6	123,4	140,8	159,3
③ Sound power	dB(A)	85	86	88	88	88	89	89
Scroll/step compressor	n.	2/2	2/3	2/3	2/3	2/2	2/3	2/2
Circuits	no.	1	1	1	1	1	1	1
Fan nominal air flow	m ³ /h	26000	27000	39000	39000	39000	52000	52000
Fan maximum available static pressure	Pa	250	250	250	250	250	250	250
Electrical supply	V-ph-Hz	400-3+N-50	400-3+N-50	400-3+N-50	400-3+N-50	400-3+N-50	400-3+N-50	400-3+N-50
DIMENSIONS		280	290	2100	2115	2130	2145	2160
L - Width	mm	3650	3650	3650	4450	4450	4450	4450
H - Height	mm	1920	1920	1920	2320	2320	2320	2320
P - Depth	mm	1100	1100	1100	1100	1100	1100	1100
④ TCCEY weight	kg	1290	1330	1395	1610	1665	1740	1750
④ THCEY weight	kg	1350	1390	1460	1680	1745	1825	1825

Data at the following conditions:

- ① Air: 35°C - Water: 12/7°C and ESP: 250 Pa.
- ② Air: 7°C D.B. - 6°C W.B. - Water: 40/45°C and ESP: 250 Pa.
- ③ Total sound power level in dB(A) based on measurements carried out in accordance with regulation UNI EN-ISO 9614.
- ④ Weight referred to the unit without load and not accessorised.
Performance according to EN 14511.

SEASONAL ENERGY PERFORMANCE		280	290	2100	2115	2130	2145	2160
TCCEY MODEL SEASONAL PERFORMANCE IN COOLING MODE								
① P _{designc} (EN 14825)	kW	79,1	87,5	100,6	113,9	125,3	142,3	160,2
① SEER (EN 14825)		4,53	4,54	4,54	4,58	4,48	4,56	4,47
② $\eta_{s,c}$	%	178	179	179	180	176	179	176
THCEY MODEL SEASONAL PERFORMANCE IN HEATING MODE								
③ P _{designh} (EN 14825)	kW	71	80	93	102	117	132	147
③ SCOP (EN 14825)		4,12	3,66	3,58	3,67	4,05	3,63	3,93
④ η_s	%	162	143	140	144	159	142	154

- ① Low temperature application (7°C)
- ② Seasonal energy efficiency: low temperature cooling (EU Regulation 2016/2281)
- ③ In Average climatic conditions, low temperature application (35°C)
- ④ Seasonal energy efficiency: low temperature heating in Average climate (EU Regulations No.811/2013 and No.813/2013)

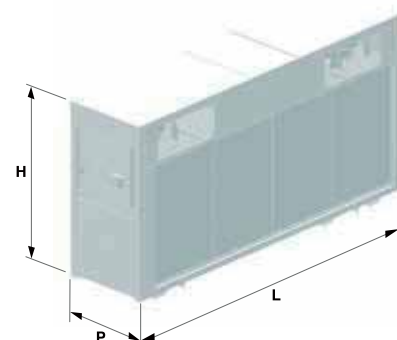

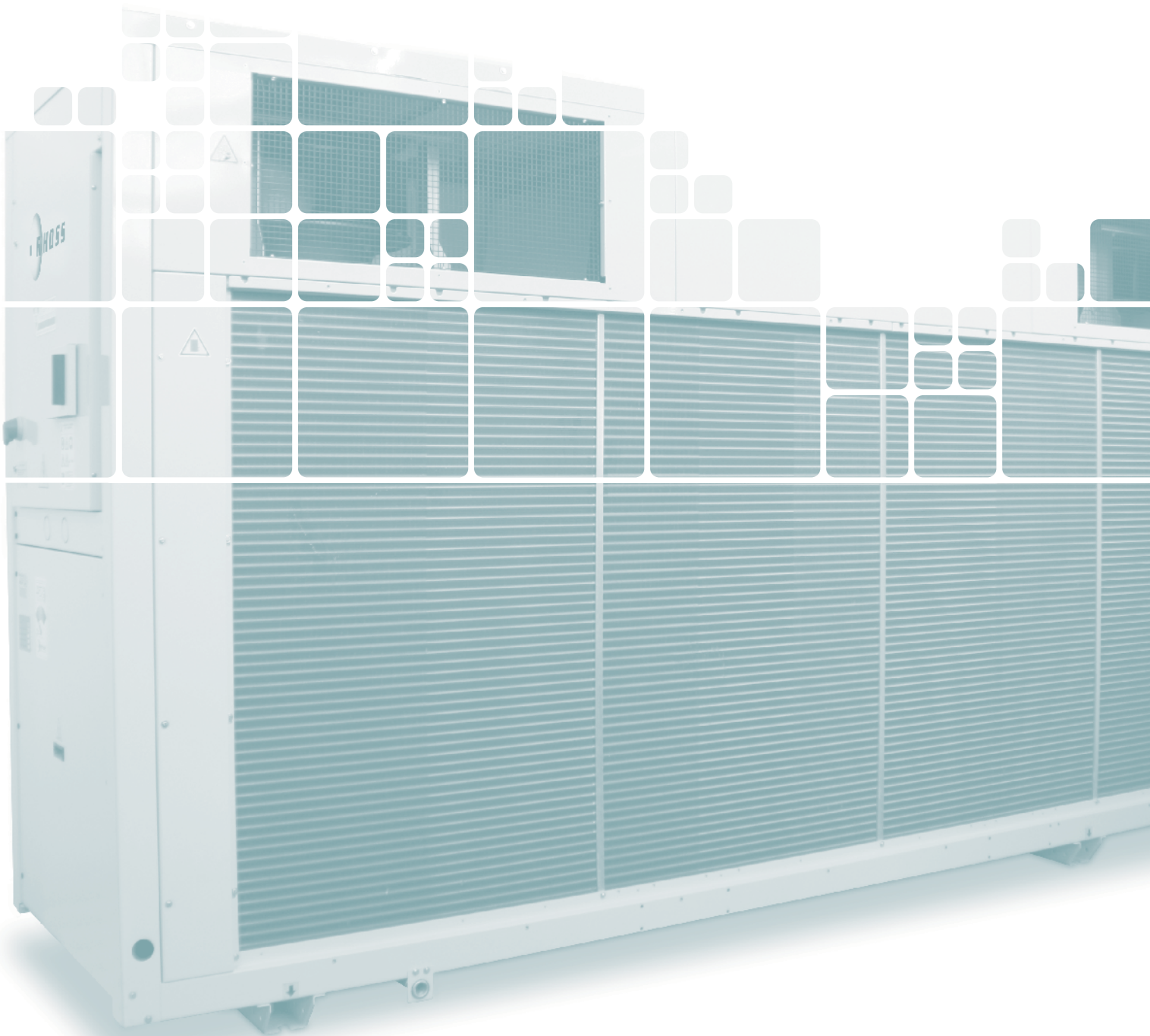

Comby-Flow - THHEY 105÷112

Y-Flow - TCHEY-THHEY 115÷240

Y-Flow - TCHEY 245÷4360 / THHEY 245÷4410

FullFLOW VFD (1+i) - TCHITL 1390÷21700

FullFLOW ECO VFD (1+i) - TCHITE 1280÷21220

FullFLOW DX - TCHVTL 1200÷21450

Y-Flow E - TCEEY 115÷240

Y-Flow E - TCEEBY 245÷4360

Z-Flow E - TCEVZ 1200÷31630

A low-angle, upward-looking shot of a large, circular glass atrium. The structure is composed of multiple concentric rings of glass panels, creating a dome-like effect. The sky is visible through the glass, showing a blue sky with light clouds. In the center of the atrium, there is a circular inset image showing a blue ocean with waves. The text is overlaid on this inset.

CHILLERS - HEAT PUMPS

Water cooled - Condenserless

Comby-Flow

THHEY 105÷112

Cooling capacity: 5.3-11.9 kW - Heating capacity: 6.6-13.7 kW



• Extremely compact and silent units

Packaged water cooled reversible heat pumps on cooling circuit with water-cooling system. Range with scroll hermetic compressors and R410A refrigerant gas.

Construction features

- Compressor: hermetic, rotary scroll type, complete with thermal protection.
- Primary side (user) heat exchanger: adequately insulated stainless steel plates, complete with antifreeze heater and water flow differential pressure switch.
- Well or mains side (disposal) heat exchanger: with suitably insulated stainless steel plates, complete with antifreeze heater and water flow differential pressure switch.
- Control: microprocessor electronic control with Adaptive Function Plus logic.
- Structure: made of galvanised and painted steel plate with polyester powder coating, complete with soundproofed compressor.

Models

- THHEY: heat pump unit.

STANDARD set up

- Without electric circulation pump.
Primary side (user): membrane expansion tank, safety valve, water drain valve, manual air vent valve, and pressure gauge.

PUMP set up

- With electric circulation pump.
Primary side (user): pump unit complete with electric circulation pump, membrane expansion tank, safety valve, water drain valve, manual air vent valve and pressure gauge.

Factory fitted accessories

- Pressure switch valve and bypass solenoid valve (only THHEY).
- Low temperature water production.
- Digital input for double set-point
- 4-20mA analogue signal for shifting set-point.

Separately supplied accessories

- Buffer tank.
- Buffer tank connection pipes.
- Water filter.
- Rubber anti-vibration mounts.
- Antifreeze heater on the buffer tank.
- Low pressure switch.
- 3-way valve for the production of domestic hot water.
- Outdoor air temperature probe for set-point compensation.
- Additional electrical resistance for heat pump, managed by regulation.
- Remote keypad with display.
- Clock board.
- Interfaces for serial communication with other devices.
- Serial converter (RS485/USB).
- Rhoss supervisors for unit monitoring and remote management.



THHEY MODEL		105	107	109	112
① Heating capacity	kW	6,58	8,1	10,9	14
① Absorbed power	kW	2,08	2,8	3,35	4,5
① C.O.P.		3,16	2,89	3,03	3,1
② Heating capacity	kW	7,5	9,7	12,7	15
② Absorbed power	kW	1,6	2,1	2,72	3,33
② C.O.P.		4,68	4,61	4,67	4,51
③ Heating capacity (geothermal)	kW	5,4	7,3	9,4	11,3
③ Absorbed power (geothermal)	kW	1,5	2,15	2,78	3,34
③ C.O.P. (geothermal)		3,62	3,39	3,38	3,39
④ Cooling capacity	kW	5,3	6,8	9,2	11,9
④ Absorbed power	kW	1,6	2,19	2,79	3,67
④ E.E.R.		3,31	3,11	3,3	3,24
⑤ Sound pressure	dB(A)	49	51	51	53
Scroll/step compressor	no.	1/1	1/1	1/1	1/1
KA buffer tank water content	l	20	20	30	30
④ Available circulator head	kPa	47	55	82	77
Electrical supply	V-ph-Hz	230-1-50	230-1-50 / 400-3+N-50	230-1-50 / 400-3+N-50	230-1-50 / 400-3+N-50
DIMENSIONS AND WEIGHTS		105	107	109	112
L - Width	mm	585	585	660	660
H - STANDARD height - PUMP	mm	535	535	535	535
H - STANDARD height - PUMP + KA	mm	855	855	855	855
P - Depth	mm	386	386	420	420
⑥ Weight	kg	78	83	94	97
KA Weight	kg	28	28	33	33

Data at the following conditions:

- ① Hot water: 40/45°C - Evaporator water: 10/7°C.
- ② Hot water: 30/35°C - Evaporator water: 10/7°C.
- ③ Hot water: 30/35°C - Evaporator water: 0/-3°C, 30% glycol.
- ④ Chilled water: 12/7°C - Condenser water: 30/35°C.
- ⑤ In open field (Q = 2) at 1 m from the unit.
- ⑥ Weight refers to the most complete setup.

Performance according to EN 14511. Standard Setup

KA = buffer tank.

KTC = connecting pipe.

SEASONAL ENERGY PERFORMANCE		105	107	109	112
THHEY MODEL SEASONAL PERFORMANCE IN HEATING MODE					
③ Pdesignh (EN 14825)	kW	9	12	16	19
③ SCOP (EN 14825)		5,38	5,56	5,54	5,18
④ η_s	%	207	214	214	199
④ Energy class		A+++	A+++	A+++	A+++

③ In Average climatic conditions, low temperature application (35°C)

④ Seasonal energy efficiency: low temperature heating in Average climate (EU Regulations No.811/2013 and No.813/2013)

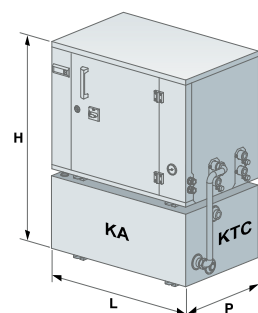
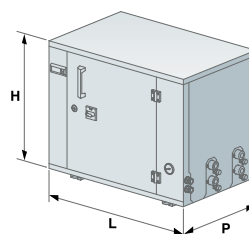

Y-Flow

TCHEY-THHEY 115÷240

Cooling capacity: 15.5-41.7 kW - Heating capacity: 17.4-45.1 kW



- Applications with well water, water mains or geothermal probes
- Plug&Play Unit with upward hydraulic connections



Packaged water-cooled water chillers and reversible heat pumps on the cooling circuit with water-cooling system. Range with scroll hermetic compressors and R410A refrigerant gas.

Construction features

- Compressor: hermetic rotary scroll complete with thermal protection and crankcase heater.
- Primary side (user) heat exchanger: adequately insulated stainless steel plates, complete with antifreeze heater and water flow differential pressure switch.
- Disposal unit side (well/mains/geothermal probes) heat exchanger: adequately insulated stainless steel plates, complete with antifreeze heater and water flow differential pressure switch (for THHEY).
- Control: microprocessor electronic control with Adaptive Function Plus logic.
- Structure: made of galvanised and painted steel plate with polyester powder coating, internally covered with soundproof panelling.

Models

- TCHEY: unit designed for cooling only.
- THHEY: heat pump unit.

Factory fitted accessories

- PUMP:
 - Primary side (user): pump unit complete with electric circulation pump with standard or oversized head, membrane expansion tank, safety valve, water fill/drain valve, manual air vent valve and pressure gauge.
 - Disposal side (geothermal probes/dry cooler): pump unit complete with phase cutting electric pump, water fill/drain valve and manual air vent valve.
- Silenced set up.
- Pressure switch valve with water flow lock solenoid.
- Pressure switch valve with water flow lock solenoid and bypass solenoid valve.
- Water circuit heat pump (for TCHEY only).
- Soft-start device.
- Low temperature water production.
- Digital input for double set-point.
- 4-20mA analogue signal for shifting set-point.

Separately supplied accessories

- 3-way valve for the production of domestic hot water.
- Additional electrical resistance for heat pump, managed by regulation.
- Outdoor air temperature probe for set-point compensation.
- Free-cooling kit.
- Water filter.
- Rubber anti-vibration mounts.
- Remote keypad with display.
- Clock board.
- Interfaces for serial communication with other devices.
- Serial converter (RS485/USB).
- Rhoss supervisors for unit monitoring and remote management.



TCHEY MODEL		115	118	122	125	230	240
❶ Cooling capacity	kW	15,5	18,4	22,7	26,3	30,5	41,7
❶ Absorbed power	kW	3,27	3,49	4,5	5,01	6,64	8,07
❶ E.E.R.		4,74	5,27	5,04	5,25	4,59	5,17
THHEY MODEL		115	118	122	125	230	240
❷ Heating capacity	kW	17,4	20,2	25,1	28,9	35,9	45,1
❷ Absorbed power	kW	3,95	4,41	5,59	6,3	8,05	10,11
❷ C.O.P.		4,4	4,58	4,49	4,59	4,46	4,46
❸ Heating capacity	kW	18,6	21,5	26,6	30,7	38,5	47,9
❸ Absorbed power	kW	3,29	3,55	4,45	5,04	6,63	8,09
❸ C.O.P.		5,66	6,05	5,97	6,09	5,81	5,92
❹ Heating capacity (geothermal)	kW	13,4	15,3	18,6	21,7	27,7	33,8
❹ C.O.P. (geothermal)		4,12	4,21	4,37	4,49	4,23	4,3
❶ Cooling capacity	kW	13,9	16,3	20	23,1	27,3	35,9
❶ E.E.R.		3,81	4,13	4,15	4,19	3,79	4,09
TCHEY - THHEY MODEL		115	118	122	125	230	240
❺ Sound pressure	dB(A)	42	42	46	47	48	52
Scroll/step compressor	n.	1/1	1/1	1/1	1/1	2/2	2/2
Circuits	no.	1	1	1	1	1	1
❶ Std system side electric pump available head	kPa	88	81	73	113	105	115
Electrical supply	V-ph-Hz	400-3+N-50	400-3+N-50	400-3+N-50	400-3+N-50	400-3+N-50	400-3+N-50
DIMENSIONS AND WEIGHTS		115	118	122	125	230	240
L - Width	mm	700	700	700	700	700	700
H - STANDARD height - PUMP	mm	1140	1140	1140	1140	1140	1140
P - Depth	mm	560	560	780	780	780	780
❻ Weight	kg	193	193	230	254	278	298

Data at the following conditions:

- ❶ Chilled water: 12/7°C - Condenser water: 30/35°C.
- ❷ Hot water: 40/45°C - Evaporator water: 10/7°C.
- ❸ Hot water: 30/35°C - Evaporator water: 10/7°C.
- ❹ Hot water: 30/35°C - Evaporator water: 0/-3°C, 30% glycol.
- ❺ In open field (Q = 2) at 1 m from the unit, with silenced setup.
- ❻ Weight refers to the most complete setup.

Performance according to EN 14511.

SEASONAL ENERGY PERFORMANCE		115	118	122	125	230	240
TCHEY MODEL SEASONAL PERFORMANCE IN COOLING MODE							
❶ P _{designc} (EN 14825)	kW	15,5	18,4	22,7	26,3	30,5	41,7
❶ SEER (EN 14825)		5,33	5,57	5,55	5,7	6,06	5,81
❷ $\eta_{s,c}$	%	210	220	219	225	239	229
THHEY MODEL SEASONAL PERFORMANCE IN HEATING MODE							
❸ P _{designh} (EN 14825)	kW	23	27	33	38	48	59
❸ SCOP (EN 14825)		6,1	6,43	6,44	6,54	6,67	6,8
❹ η_s	%	236	249	249	254	259	264
❹ Energy class		A+++	A+++	A+++	A+++	A+++	A+++

- ❶ Low temperature application (7°C)
- ❷ Seasonal energy efficiency: low temperature cooling (EU Regulation 2016/2281)
- ❸ In Average climatic conditions; low temperature application (35°C)
- ❹ Seasonal energy efficiency: low temperature heating in Average climate (EU Regulations No.811/2013 and No.813/2013)



Y-Flow

TCHEY 245÷4360 / THHEY 245÷4410

Cooling capacity: 41.2-373.9 kW - Heating capacity: 50.2-464.4 kW



- Applications with well water, water mains or geothermal probes
- Integrated MASTER/SLAVE control
- HT65 version for 65°C water production (°)



TCHEY 2100

Packaged water-cooled water chillers and reversible heat pumps on the cooling circuit with water-cooling system. Range with scroll hermetic compressors and R410A refrigerant gas.

Construction features

- Compressor: hermetic rotary scroll complete with thermal protection and crankcase heater.
- Primary side (user) heat exchanger: adequately insulated stainless steel plates, complete with antifreeze heater and water flow differential pressure switch.
- Disposal unit side (well/mains/geothermal probes) heat exchanger: adequately insulated stainless steel plates, complete with antifreeze heater and water flow differential pressure switch (for THHEY).
- Control: microprocessor electronic control with Adaptive Function Plus logic.
- Structure: made of galvanised and painted steel plate with polyester powder coating.
- The unit is also complete with:
 - compressor circuit breaker switches;
 - display of cooling circuit high and low pressure;
 - Master/Slave control up to 4 units in parallel;
 - clock board;
 - 0-10V analogue signal for condensing/evaporating control performed by external device;
 - control of Variable Primary Flow (VPF_R).

Versions

- LT - Hot water production up to 52°C.
- HT - Hot water production up to 55°C.

Models

- TCHEY: unit designed for cooling only.
- THHEY: heat pump unit.

Factory fitted accessories

- PUMP primary side (user): with single or double electric pump, including an automatic pump in standby, complete with expansion tank, safety valve, water fill/drain valve, air vent valve and pressure gauge. The electric pumps are available in the low or high pressure head versions. →
- PUMP disposal side (geothermal probes/dry cooler): with single or double electric pump regulated via inverter including an automatic actuation pump in standby. →
- Desuperheater. →
- 100% heat recovery unit (mod. 245-4360). →
- Water circuit heat pump (for TCHEY only).
- Inverter pump control for unit start-up.
- Power factor correction capacitors ($\cos\phi > 0.94$).
- Soft-starter.
- Energy parameter measuring device.
- Cooling circuit outlet and inlet valves.
- Refrigerant leak detector.
- Forced limit of power consumption.
- Cooling circuit high and low pressure gauges.
- Double safety valves.
- Silenced set up.
- Control of min/max power supply voltage.
- Low temperature water production.
- Digital input for double set-point.
- 4-20mA analogue signal for shifting set-point.
- Interfaces for serial communication with other devices.
- Rubber anti-vibration mounts.

(°) Refer to the specific documentation to check available models and accessories.

→ The units can be equipped with up to a maximum of 2 electric pumps in mod. 245-2185 and 4 electric pumps in mod. 4180-4410. The PUMP set up is not included when there is a recovery unit or desuperheater.



THEY 4260

Separately supplied accessories

- 3-way modulating condensing control valve.
- 2-way modulating condensing control valve.
- Outdoor air temperature probe for set-point compensation.
- Free-cooling kit (mod. 245-2185).
- Water filter.
- Remote keypad with display.
- Thermostat with display.
- Serial converter (RS485/USB).
- Rhoss supervisors for unit monitoring and remote management.
- Rhoss sequencer for integrated management of multiple chillers.

Y-Flow

TCHEY 245÷4360 / THHEY 245÷4410

TCHEY HT MODEL		245	250	260	270	275	290	2100	2115	2130	2145	2165	2185
① Cooling capacity	kW	45,1	53,1	60,4	69	75,6	89,8	102,8	117	130,7	145,4	165,1	184,3
① Absorbed power	kW	9,8	11,34	13,1	14,93	16,39	19,1	22,34	25,43	28,78	31,67	36,85	41,79
① E.E.R.		4,6	4,68	4,61	4,62	4,61	4,7	4,6	4,6	4,54	4,59	4,48	4,41
THHEY HT MODEL		245	250	260	270	275	290	2100	2115	2130	2145	2165	2185
② Heating capacity	kW	50,2	59	67,8	75,6	84	102,2	116,5	133,6	147,7	163,2	186,6	209,4
② Absorbed power	kW	12,18	13,91	15,87	17,66	19,85	23,76	28,2	31,36	35,25	39,32	45,73	51,96
② C.O.P.		4,12	4,24	4,27	4,28	4,23	4,3	4,13	4,26	4,19	4,15	4,08	4,03
① Cooling capacity	kW	41,3	48,5	55,2	63	69,2	82	96,1	109,3	120,8	134,5	152,4	170,1
① E.E.R.		4,32	4,38	4,36	4,31	4,31	4,31	4,3	4,35	4,3	4,29	4,08	4,02
TCHEY - THHEY MODEL		245	250	260	270	275	290	2100	2115	2130	2145	2165	2185
③ Sound power	dB(A)	67	67	68	68	69	70	71	72	73	74	74	75
Scroll/step compressor	n.	2/2	2/2	2/2	2/2	2/3	2/2	2/3	2/3	2/3	2/2	2/3	2/2
Circuits	n.	1	1	1	1	1	1	1	1	1	1	1	1
Electrical supply	V-ph-Hz	400-3+N-50	400-3+N-50	400-3+N-50	400-3+N-50	400-3+N-50	400-3+N-50	400-3+N-50	400-3+N-50	400-3+N-50	400-3+N-50	400-3+N-50	400-3+N-50
DIMENSIONS AND WEIGHTS		245	250	260	270	275	290	2100	2115	2130	2145	2165	2185
④ L - Width	mm	1020	1020	1020	1020	1020	1020	1270	1270	1270	1270	1270	1270
⑤ L - Width	mm	1250	1250	1250	1250	1250	1250	1500	1500	1500	1500	1500	1500
H - Height	mm	1470	1470	1470	1470	1470	1470	1620	1620	1620	1620	1620	1620
P - Depth	mm	870	870	870	870	870	870	870	870	870	870	870	870
⑥ Weight TCHEY LT	kg	395	405	410	425	435	450	695	710	730	755	770	775
⑥ Weight TCHEY HT	kg	425	430	440	460	470	480	740	770	800	825	850	855
⑥ Weight THHEY LT	kg	405	415	425	440	450	460	700	720	750	755	790	800
⑥ Weight THHEY HT	kg	435	445	455	470	480	495	755	790	820	845	870	880

Data at the following conditions:

- ① Chilled water: 12/7°C. - Condenser water: 30/35°C.
- ② Hot water: 40/45°C. - Evaporator water: 10/7°C.
- ③ Total sound power level in dB(A) based on measurements carried out in accordance with regulation UNI EN-ISO 9614.
- ④ Width referring to the unit with standard setup or supplied with "recovery" or "desuperheater" accessories.
- ⑤ Width referring to the PUMP setup, up to a maximum of 2 pumps in mod. 245-2185 (2 user side or disposal unit side pumps or 1 user side pump + 1 disposal unit side pump) and up to a maximum of 4 pumps in mod. 4180-4410 (2 pumps on user side and 2 pumps on disposal unit side).
- ⑥ Empty weight
Performance according to EN 14511.

SEASONAL ENERGY PERFORMANCE		245	250	260	270	275	290	2100	2115	2130	2145	2165	2185
TCHEY HT MODEL SEASONAL PERFORMANCE IN COOLING MODE													
① Pdesignc (EN 14825)	kW	45,1	53,1	60,4	69	75,6	89,8	102,8	117	130,7	145,4	165,1	184,3
① SEER (EN 14825)		5,75	5,98	6,08	5,94	6,26	6,04	6,02	6,17	6,1	6,01	6,2	5,9
② $\eta_{s,c}$	%	227	236	240	235	248	239	238	244	241	237	245	233
THHEY HT MODEL SEASONAL PERFORMANCE IN COOLING MODE													
① Pdesignc (EN 14825)	kW	-	-	-	-	-	-	-	-	-	-	-	-
① SEER (EN 14825)		-	-	-	-	-	-	-	-	-	-	-	-
② $\eta_{s,c}$	%	-	-	-	-	-	-	-	-	-	-	-	-
THHEY HT MODEL SEASONAL PERFORMANCE IN HEATING MODE													
③ Pdesignh (EN 14825)	kW	61	71	81	91	101	122	140	159	174	196	224	250
③ SCOP (EN 14825)		6,54	6,59	6,48	6,46	6,72	6,38	6,1	6,38	6,16	6,1	6,16	5,89
④ η_s	%	254	255	251	251	261	247	236	247	239	236	239	228
④ Energy class		A+++	-	-	-	-	-	-	-	-	-	-	-

- ① Low temperature application (7°C)
- ② Seasonal energy efficiency: low temperature cooling (EU Regulation 2016/2281)
- ③ In Average climatic conditions, low temperature application (35°C)
- ④ Seasonal energy efficiency: low temperature heating in Average climate (EU Regulations No.811/2013 and No.813/2013)

TCHEY HT MODEL		4180	4205	4235	4260	4290	4330	4360	4410	
❶	Cooling capacity	kW	180,9	206,9	232,6	260,2	287,5	326	363,1	-
❶	Absorbed power	kW	37,45	42,83	48,25	54,2	60,27	69,36	79,1	-
❶	E.E.R.		4,83	4,83	4,82	4,8	4,77	4,7	4,59	-
THHEY HT MODEL		4180	4205	4235	4260	4290	4330	4360	4410	
❷	Heating capacity	kW	201,8	230,5	258,7	291,7	323,7	369	413,8	464,1
❷	Absorbed power	kW	45,55	52,86	60,3	67,83	75,63	87,64	99,23	116,6
❷	C.O.P.		4,43	4,36	4,29	4,3	4,28	4,21	4,17	3,98
❶	Cooling capacity	kW	160,7	183,7	206,8	231,7	255,4	293	330,4	374
❶	E.E.R.		4,42	4,29	4,22	4,19	4,16	4,14	4,16	4,1
TCHEY - THHEY MODEL		4180	4205	4235	4260	4290	4330	4360	4410	
❸	Sound power	dB(A)	77	77	78	79	80	81	82	83
	Scroll/step compressor	n.	4/3	4/3	4/3	4/3	4/3	4/3	4/3	4/3
	Circuits	n.	2	2	2	2	2	2	2	2
	Electrical supply	V-ph-Hz	400-3-50	400-3-50	400-3-50	400-3-50	400-3-50	400-3-50	400-3-50	400-3-50
DIMENSIONS AND WEIGHTS		4180	4205	4235	4260	4290	4330	4360	4410	
❹	L - Width	mm	2600	2600	2600	2600	2600	2600	2600	2600
❺	L - Width	mm	3734	3734	3734	3734	3734	3734	3734	3734
	H - Height	mm	1860	1860	1860	1860	1860	1860	1860	1860
	P - Depth	mm	870	870	870	870	870	870	870	870
❻	Weight TCHEY LT	kg	1350	1410	1440	1460	1500	1530	1570	-
❻	Weight TCHEY HT	kg	1440	1470	1510	1540	1600	1650	1680	-
❻	Weight THHEY LT	kg	1380	1440	1470	1500	1530	1560	1600	1750
❻	Weight THHEY HT	kg	1470	1500	1550	1570	1630	1680	1720	1790

Data at the following conditions:

- ❶ Chilled water: 12/7°C. - Condenser water: 30/35°C.
- ❷ Hot water: 40/45°C. - Evaporator water: 10/7°C.
- ❸ Total sound power level in dB(A) based on measurements carried out in accordance with regulation UNI EN-ISO 9614.
- ❹ Width referring to the unit with standard setup or supplied with "recovery" or "desuperheater" accessories.
- ❺ Width referring to the PUMP setup, up to a maximum of 2 pumps in mod. 245-2185 (2 user side or disposal unit side pumps or 1 user side pump + 1 disposal unit side pump) and up to a maximum of 4 pumps in mod. 4180-4410 (2 pumps on user side and 2 pumps on disposal unit side).
- ❻ Empty weight
Performance according to EN 14511.

SEASONAL ENERGY PERFORMANCE		4180	4205	4235	4260	4290	4330	4360	4410	
TCHEY HT MODEL SEASONAL PERFORMANCE IN COOLING MODE										
❶	P _{designc} (EN 14825)	kW	180,9	206,9	232,6	260,2	287,5	326	363,1	-
❶	SEER (EN 14825)		5,89	6,1	6,3	6,32	6,36	6,28	6,21	-
❷	$\eta_{s,c}$	%	233	241	249	250	251	248	245	-
THHEY HT MODEL SEASONAL PERFORMANCE IN COOLING MODE										
❶	P _{designc} (EN 14825)	kW	-	-	-	-	255,4	293	330,4	374
❶	SEER (EN 14825)		-	-	-	-	6,05	6	6,11	5,7
❷	$\eta_{s,c}$	%	-	-	-	-	239	237	241	225
THHEY HT MODEL SEASONAL PERFORMANCE IN HEATING MODE										
❸	P _{designh} (EN 14825)	kW	262	302	340	383	-	-	-	-
❸	SCOP (EN 14825)		6,93	6,68	6,54	6,52	-	-	-	-
❹	η_s	%	269	259	253	253	-	-	-	-
❹	Energy class		-	-	-	-	-	-	-	-

- ❶ Low temperature application (7°C)
- ❷ Seasonal energy efficiency: low temperature cooling (EU Regulation 2016/2281)
- ❸ In Average climatic conditions, low temperature application (35°C)
- ❹ Seasonal energy efficiency: low temperature heating in Average climate (EU Regulations No.811/2013 and No.813/2013)

FullFLOW VFD (1+i)

TCHITL 1390÷21700

Cooling capacity: 389.5-1701.1 kW

INVERTER

- Non-flammable reduced GWP gas
- High efficiency levels
- Continuous power regulation
- Various soundproofing options
- Touch interface (optional)
- Free-Cooling management
- Integrated MASTER/SLAVE control



TCHITL 21000 with TOBT accessory

Water-cooled water chillers.
Range with semi-hermetic screw compressors with variable V_i , inverter regulation and R513A refrigerant gas.

Construction features

- Compressor: high energy efficiency semi-hermetic screw driven by fixed speed motor with linear capacity control and/or variable V_i regulated by inverter (25%-100% single-compressor sizes, 12.5-100% bi-compressor sizes), limited start, complete with integral protection, casing heater, oil level sensor and shut-off valves on delivery and intake piping.
- Water side heat exchanger (evaporator): low refrigerant charge spray flooded type shell and tube exchanger, complete with closed cell polyurethane foam rubber insulation, water flow differential pressure switch and Victaulic fittings.
- Water side heat exchanger (condenser): tube and shell complete with safety valve, service valve on the high-pressure refrigerant gas circuit, and a water flow differential pressure switch and Victaulic fittings.
- Control: microprocessor electronic control.
- Structure: made of galvanised and painted steel plate with polyester powder coating.
- The unit is also complete with:
 - clock board;
 - electronic expansion valve;
 - display of cooling circuit high/low pressure;
 - Master/Slave control up to 4 units in parallel;
 - 0-10V analogue signal for condensing control from external device;
 - control of Variable Primary Flow (VPF_R).

Versions

- T - High efficiency version

Models

- TCHITL: unit designed for cooling only.

Factory fitted accessories

- Free-Cooling management
- Dry-Cooler management
- 100% heat recovery unit.
- Set up for heat pump operation.
- Power factor correction capacitors ($\cos\phi > 0.94$).
- Circuit breaker switches.
- Forced limit of power consumption.
- Soft starter.
- Electro-mechanical flow switch.
- EMC anti-disturbance filters.
- Energy parameter measuring device.
- Compressor soundproof enclosures.
- Full acoustic casing.
- Refrigerant leak detector.
- Double safety valves.
- Digital input for double set-point.
- 4-20 mA analogue signal for shifting set-point.
- Evaporator antifreeze heater.
- Control of min/max power supply voltage.
- Interfaces for serial communication with other devices.
- Colour touch user keypad (fitted on the machine or remotely) with 7" display.
- Anti-vibration mounts.

Separately supplied accessories

- Remote keypad with display.
- Outdoor air temperature probe for set-point compensation
- Thermostat with display.
- Rhoss supervisors for unit monitoring and remote management.
- Rhoss sequencer for integrated management of multiple chillers.



TCHITL MODEL		1390	1490	1600	2720	2810	2900	21000	21110	21260	21360	21520	21700
❶ Nominal cooling capacity	kW	389,5	486,5	610,4	727,4	816,3	920,3	1001,3	1117,2	1260,2	1361,1	1524,2	1701,1
❶ E.E.R.		5,18	5,16	5,11	5,5	5,41	5,5	5,45	5,32	5,36	5,4	5,57	5,55
❶ Absorbed power	kW	75,2	94,3	119,5	132,3	150,9	167,3	183,7	210	235,1	252,1	273,6	306,5
❷ Sound power	dB(A)	97	99	101	98	98	100	100	102	103	103	102	103
❷ Sound power with enclosure accessory	dB(A)	93	95	97	94	94	96	96	98	99	99	98	99
Screw/step compressor	n.	1/ REGOLAZIONE CONTINUA	1/ REGOLAZIONE CONTINUA	1/ REGOLAZIONE CONTINUA	2/ REGOLAZIONE CONTINUA	2/ REGOLAZIONE CONTINUA	2/ REGOLAZIONE CONTINUA	2/ REGOLAZIONE CONTINUA	2/ REGOLAZIONE CONTINUA	2/ REGOLAZIONE CONTINUA	2/ REGOLAZIONE CONTINUA	2/ REGOLAZIONE CONTINUA	2/ REGOLAZIONE CONTINUA
Circuits	n.	1	1	1	2	2	2	2	2	2	2	2	2
Electrical supply	V-ph-Hz	400-3-50	400-3-50	400-3-50	400-3-50	400-3-50	400-3-50	400-3-50	400-3-50	400-3-50	400-3-50	400-3-50	400-3-50
DIMENSIONS AND WEIGHTS		1390	1490	1600	2720	2810	2900	21000	21110	21260	21360	21520	21700
L - Width	mm	3859	3859	3859	3990	3990	3990	4329	4407	4407	4407	4501	4586
H - Height	mm	1830	1830	1830	2040	2040	2040	2040	2040	2080	2080	2090	2090
P - Depth	mm	1531	1531	1591	1676	1676	1676	1676	1814	1844	1844	1979	2024
❸ TCHITL weight	kg	2460	2530	2605	4700	4830	4915	5385	5600	6325	6455	7765	8115

Data at the following conditions:

- ❶ Chilled water: 7/12°C. - Condenser inlet water: 30/35°C.
- ❷ Total sound power level in dB(A) based on measurements carried out in accordance with regulation UNI EN-ISO 9614.
- ❸ Empty weight.

Performance according to EN 14511.

SEASONAL ENERGY PERFORMANCE		1390	1490	1600	2720	2810	2900	21000	21110	21260	21360	21520	21700
TCHITL MODEL SEASONAL PERFORMANCE IN COOLING MODE													
❶ Pdesignc (EN 14825)	kW	389,5	486,5	610,4	727,4	816,3	920,3	1001,3	1117,2	1260,2	1361,1	1524,2	1701,1
❶ SEER (EN 14825)		8,52	8,22	8,16	8,18	8,43	8,34	8,1	8,04	8	8,03	8,1	7,96
❷ $\eta_{s,c}$	%	338	326	323	324	334	331	321	319	317	318	321	316

- ❶ Low temperature application (7°C)
- ❷ Seasonal energy efficiency: low temperature cooling (EU Regulation 2016/2281)

FullFLOW ECO VFD (1+i)

TCHITE 1280÷21220

Cooling capacity: 285.6-1217.2 kW

INVERTER

- HFO R1234ze ecological gas
- High efficiency levels
- Continuous power regulation
- Various soundproofing options
- Touch interface (optional)
- Free-Cooling management
- Integrated MASTER/SLAVE control



TCHITE 21000 with TOBT accessory

Water-cooled water chillers.
Range with semi-hermetic screw compressors with variable Vi, inverter regulation and R1234ze refrigerant gas.

Construction features

- Compressor: high energy efficiency semi-hermetic screw driven by fixed speed motor with linear capacity control and/or variable Vi regulated by inverter (25-100% single-compressor sizes, 12.5-100% bi-compressor sizes), limited start, complete with integral protection, casing heater, oil level sensor and shut-off valves on delivery and intake piping.
- Water side heat exchanger (evaporator): low refrigerant charge spray flooded type shell and tube exchanger, complete with closed cell polyurethane foam rubber insulation, water flow differential pressure switch and Victaulic fittings.
- Water side heat exchanger (condenser): tube and shell complete with safety valve, service valve on the high-pressure refrigerant gas circuit, and a water flow differential pressure switch and Victaulic fittings.
- Control: microprocessor electronic control.
- Structure: made of galvanised and painted steel plate with polyester powder coating.
- The unit is also complete with:
 - clock board;
 - electronic expansion valve;
 - display of cooling circuit high/low pressure;
 - Master/Slave control up to 4 units in parallel;
 - 0-10V analogue signal for condensing control from external device;
 - control of Variable Primary Flow (VPF_R).

Versions

- T - High efficiency version

Models

- TCHITE: unit designed for cooling only.

Factory fitted accessories

- Free-Cooling management
- Dry-Cooler management
- 100% heat recovery unit.
- Set up for heat pump operation.
- Power factor correction capacitors ($\cos\phi > 0.94$).
- Circuit breaker switches.
- Forced limit of power consumption.
- Soft starter.
- Electro-mechanical flow switch.
- EMC anti-disturbance filters.
- Energy parameter measuring device.
- Compressor soundproof enclosures.
- Full acoustic casing.
- Refrigerant leak detector.
- Double safety valves.
- Digital input for double set-point.
- 4-20 mA analogue signal for shifting set-point.
- Evaporator antifreeze heater.
- Control of min/max power supply voltage.
- Interfaces for serial communication with other devices.
- Colour touch user keypad (fitted on the machine or remotely) with 7" display.
- Anti-vibration mounts.

Separately supplied accessories

- Remote keypad with display.
- Outdoor air temperature probe for set-point compensation.
- Thermostat with display.
- Rhoss supervisors for unit monitoring and remote management.
- Rhoss sequencer for integrated management of multiple chillers.



TCHITE MODEL		1280	1340	1430	2520	2580	2650	2710	2800	2890	2970	21090	21220
① Nominal cooling capacity	kW	285,6	346,6	434,5	524,4	584,4	648,4	719,4	800,4	897,3	974,3	1091,2	1217,2
① E.E.R.		5,2	5,19	5,05	5,47	5,44	5,43	5,5	5,33	5,32	5,39	5,54	5,54
① Absorbed power	kW	54,9	66,8	86	95,9	107,4	119,4	130,8	150,2	168,7	180,8	197	219,7
② Sound power	dB(A)	97	99	101	98	98	100	100	102	103	103	102	103
② Sound power with enclosure accessory	dB(A)	93	95	97	94	94	96	96	98	99	99	98	99
Screw/step compressor	n.	1/ REGOLAZIONE CONTINUA	1/ REGOLAZIONE CONTINUA	1/ REGOLAZIONE CONTINUA	2/ REGOLAZIONE CONTINUA	2/ REGOLAZIONE CONTINUA	2/ REGOLAZIONE CONTINUA	2/ REGOLAZIONE CONTINUA	2/ REGOLAZIONE CONTINUA	2/ REGOLAZIONE CONTINUA	2/ REGOLAZIONE CONTINUA	2/ REGOLAZIONE CONTINUA	2/ REGOLAZIONE CONTINUA
Circuits	n.	1	1	1	2	2	2	2	2	2	2	2	2
Electrical supply	V-ph-Hz	400-3-50	400-3-50	400-3-50	400-3-50	400-3-50	400-3-50	400-3-50	400-3-50	400-3-50	400-3-50	400-3-50	400-3-50
DIMENSIONS AND WEIGHTS		1280	1340	1430	2520	2580	2650	2710	2800	2890	2970	21090	21220
L - Width	mm	3859	3859	3859	4008	4008	3990	4329	4407	4407	4407	4501	4586
H - Height	mm	1830	1830	1830	1910	1910	2040	2040	2040	2040	2040	2080	2080
P - Depth	mm	1531	1531	1591	1676	1676	1676	1676	1814	1844	1844	1964	2009
③ TCHITE weight	kg	2335	2440	2535	4095	4190	4735	5205	5355	5620	5765	6790	7135

Data at the following conditions:

- ① Chilled water: 7/12°C. - Condenser inlet water: 30/35°C.
- ② Total sound power level in dB(A) based on measurements carried out in accordance with regulation UNI EN-ISO 9614.
- ③ Empty weight.

Performance according to EN 14511.

SEASONAL ENERGY PERFORMANCE

TCHITE MODEL SEASONAL PERFORMANCE IN COOLING MODE

① Pdesignc (EN 14825)	kW	285,6	346,6	434,5	524,4	584,4	648,4	719,4	800,4	897,3	974,3	1091,2	1217,2
① SEER (EN 14825)		8,41	8,18	8,09	8,11	8,34	8,23	7,84	8,02	7,88	7,94	7,97	7,96
② $\eta_{s,c}$	%	333	324	321	321	331	326	311	318	312	315	316	315

- ① Low temperature application (7°C)
- ② Seasonal energy efficiency: low temperature cooling (EU Regulation 2016/2281)

FullFLOW DX

TCHVTL 1200÷21450

new

Cooling capacity: 201.7-1.455.2 kW



- Non-flammable reduced GWP gas
- Various soundproofing options
- Touch interface (optional)
- Free-Cooling management
- Integrated MASTER/SLAVE control

Water-cooled water chillers.
Range with stepless semi-hermetic screw compressors and R513A ecological refrigerant gas.

Construction features

- Compressor: high energy efficiency semi-hermetic screw compressor with control of linear capacity, with star-delta or part-winding start up (depending on models) and complete with integral protection, casing heater and refrigerant gas outlet piping shut-off valve.
- Water side heat exchanger (evaporator): dry expansion shell and tube exchanger with counterflow heat exchange, complete with closed cell polyurethane foam rubber insulation, water flow differential pressure switch and Victaulic fittings. Antifreeze heater sizes 1200-1230.
- Water side heat exchanger (condenser): tube and shell complete with differential pressure switch, safety valve, service valve on the high-pressure refrigerant gas circuit.
- Control: microprocessor electronic control.
- Structure: made of galvanised and painted steel plate with polyester powder coating.
- The unit is also complete with:
 - clock board;
 - display of cooling circuit high/low pressure;
 - electronic expansion valve;
 - Master/Slave control up to 4 units in parallel;
 - 0-10V analogue signal for condensing control from external device;
 - control of Variable Primary Flow (VPF_R).

Versions

- T - High efficiency version

Models

- TCHVTL: unit designed for cooling only.

Factory fitted accessories

- 100% heat recovery unit.
- Free-Cooling Management.
- Dry-Cooler Management.
- Set up for heat pump operation.
- Condenser Victaulic fittings.
- Power factor correction capacitors ($\cos\phi > 0.94$).
- Circuit breaker switches.
- Forced limit of power consumption.
- Soft starter.
- Inlet compressor shut-off valves.
- Energy parameter measuring device.
- Electro-mechanical flow switch.
- Digital input for double set-point.
- Compressor soundproof enclosures.
- Refrigerant leak detector.
- Full acoustic casing.
- Compressor oil level sensor.
- Double safety valves.
- Control of min/max power supply voltage.
- 4-20 mA analogue signal for shifting set-point.
- Evaporator antifreeze heater (sizes 1290-21450).
- Interfaces for serial communication with other devices.
- Colour touch user keypad (fitted on the machine or remotely) with 7" display.
- Anti-vibration mountings supplied loose.
- Protective packaging

Separately supplied accessories

- Remote keypad with display.
- Outdoor air temperature probe for set-point compensation
- Thermostat with display.
- Rhoss supervisors for unit monitoring and remote management.
- Rhoss sequencer for integrated management of multiple chillers.



TCHVTL MODEL		1200	1230	1290	1320	1380
① Nominal cooling capacity	kW	201,7	229,7	289,7	315,6	374,5
① E.E.R.		4,66	4,65	4,73	4,65	4,74
① Absorbed power	kW	43,3	49,4	61,2	67,9	79
② Sound power	dB(A)	94	94	96	96	96
Screw/step compressor	no.	1 / REGOLAZIONE CONTINUA LINEARE 50-100%				
Circuits	no.	1	1	1	1	1
Electrical supply	V-ph-Hz	400-3-50				
DIMENSIONS AND WEIGHT		1200	1230	1290	1320	1380
L - Width	mm	2860	2860	3460	3460	3460
H - Height	mm	1670	1670	1670	1670	1670
P - Depth	mm	1000	1000	1000	1000	1000
③ TCHVTL weight	kg	1300	1320	1720	1730	1740

Data at the following conditions:

- ① Chilled water: 7/12°C. - Condenser inlet water: 30/35°C.
- ② Total sound power level in dB(A) based on measurements carried out in accordance with regulation UNI EN-ISO 9614.
- ③ Empty weight.

Performance according to EN 14511.

SEASONAL ENERGY PERFORMANCE		1200	1230	1290	1320	1380
TCHVTL MODEL SEASONAL PERFORMANCE IN COOLING MODE						
① P _{designc} (EN 14825)	kW	201,7	229,7	289,7	315,6	374,5
① SEER (EN 14825)		5,82	5,82	5,62	5,73	5,82
② η _{s,c}	%	230	230	222	226	230

- ① Low temperature application (7°C)
- ② Seasonal energy efficiency: low temperature cooling (EU Regulation 2016/2281)

TCHVTL MODEL		2430	2490	2540	2620	2690	2770	2860	2950
① Nominal cooling capacity	kW	433,6	487,5	543,5	618,4	691,4	774,4	859,4	950,4
① E.E.R.		4,9	4,77	4,8	4,77	4,81	4,9	4,9	4,92
① Absorbed power	kW	88,5	102,2	113,2	129,6	143,7	158	175,4	193,2
② Sound power	dB(A)	97	97	97	97	97	98	98	99
Screw/step compressor	no.	2 / REGOLAZIONE CONTINUA LINEARE 25-100%							
Circuits	no.	2	2	2	2	2	2	2	2
Electrical supply	V-ph-Hz	400-3-50							
DIMENSIONS AND WEIGHT		2430	2490	2540	2620	2690	2770	2860	2950
L - Width	mm	4060	4060	4060	4210	4240	4670	4710	4850
H - Height	mm	1850	1850	1850	1900	1900	1980	1980	2130
P - Depth	mm	1320	1320	1320	1320	1320	1320	1320	1320
③ TCHVTL weight	kg	2400	2400	2750	3140	3260	3510	3630	4640

Data at the following conditions:

- ① Chilled water: 7/12°C. - Condenser inlet water: 30/35°C.
- ② Total sound power level in dB(A) based on measurements carried out in accordance with regulation UNI EN-ISO 9614.
- ③ Empty weight.

Performance according to EN 14511.

SEASONAL ENERGY PERFORMANCE		2430	2490	2540	2620	2690	2770	2860	2950
TCHVTL MODEL SEASONAL PERFORMANCE IN COOLING MODE									
① P _{designc} (EN 14825)	kW	433,6	487,5	543,5	618,4	691,4	774,4	859,4	950,4
① SEER (EN 14825)		6,58	6,46	6,43	6,39	6,39	6,54	6,45	6,39
② η _{s,c}	%	260	255	254	253	252	259	255	253

- ① Low temperature application (7°C)
- ② Seasonal energy efficiency: low temperature cooling (EU Regulation 2016/2281)

FuIIFLOW DX

TCHVTL 1200÷21450

TCHVTL MODEL		21030	21100	21180	21250	21310	21390	21450
①	Nominal cooling capacity	kW	1025,4	1098,3	1173,2	1250,2	1310,3	1455,2
①	E.E.R.		4,9	4,86	4,86	4,87	4,85	4,83
①	Absorbed power	kW	209,3	226	241,4	256,7	270,2	301,3
②	Sound power	dB(A)	99	99	99	99	99	100
	Screw/step compressor	no.	2 / REGOLAZIONE CONTINUA LINEARE 25-100%					
	Circuits	no.	2	2	2	2	2	2
	Electrical supply	V-ph-Hz	400-3-50					
DIMENSIONS AND WEIGHT		21030	21100	21180	21250	21310	21390	21450
	L - Width	mm	4850	4850	4850	5150	5160	5130
	H - Height	mm	2130	2230	2230	2230	2250	2350
	P - Depth	mm	1320	1320	1320	1320	1320	1320
③	TCHVTL weight	kg	4680	4830	4940	5030	5220	5590

Data at the following conditions:

- ① Chilled water: 7/12°C. - Condenser inlet water: 30/35°C.
 - ② Total sound power level in dB(A) based on measurements carried out in accordance with regulation UNI EN-ISO 9614.
 - ③ Empty weight.
- Performance according to EN 14511.

SEASONAL ENERGY PERFORMANCE		21030	21100	21180	21250	21310	21390	21450
TCHVTL MODEL SEASONAL PERFORMANCE IN COOLING MODE								
①	P _{design,c} (EN 14825)	kW	1025,4	1.098,3	1.173,2	1.250,2	1.310,3	1.391,2
①	SEER (EN 14825)		6,38	6,38	6,41	6,41	6,43	6,39
②	η _{s,c}	%	252	252	253	253	254	253

- ① Low temperature application (7°C)
- ② Seasonal energy efficiency: low temperature cooling (EU Regulation 2016/2281)

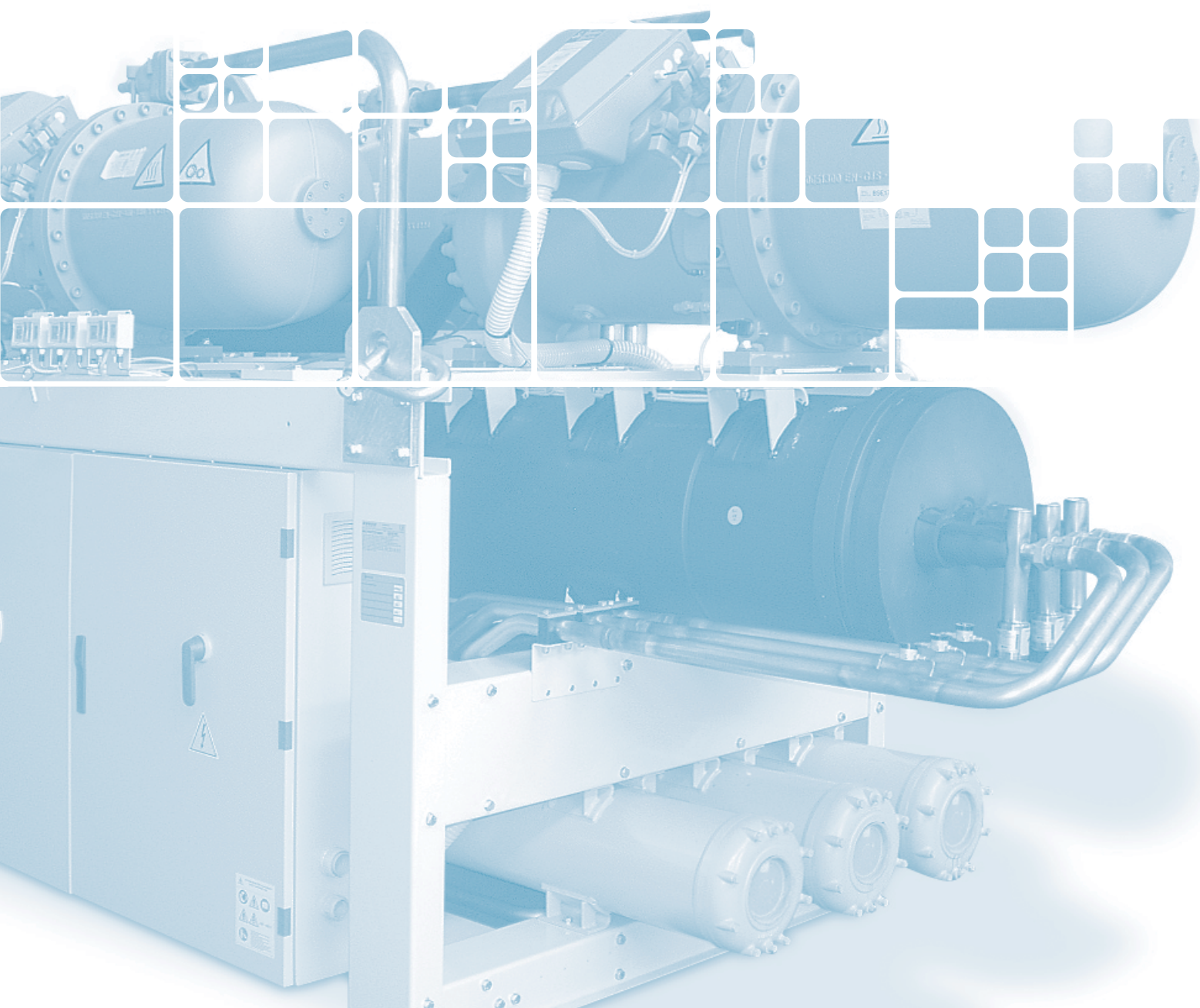

Y-Flow E

TCEEY 115÷240

Cooling capacity: 13.7-36.9 kW



- **Efficient condenserless unit in R410A**

Cooling only condenserless units. Range with scroll hermetic compressors and R410A refrigerant gas.

Construction features

- Compressor: hermetic rotary scroll complete with thermal protection and crankcase heater.
- Water side heat exchanger: adequately insulated stainless steel plates, complete with antifreeze heater and water flow differential pressure switch.
- Control: microprocessor electronic control, with Adaptive Function Plus logic.
- Structure: in galvanised and painted steel plate coated with polyester powder, internally lined with soundproof panelling.

Models

TCEEY: unit designed for cooling only.

Factory fitted accessories

- PUMP - Primary side (user): pump unit complete with electric circulation pump, membrane expansion tank, safety valve, water fill/drain valve, manual air vent valve, and pressure gauge. The electric pumps are available with low or high head.
- Soft start device.
- Silenced set up with double panelling in the compressor compartment.
- Digital input for double set-point.
- 4-20 mA analogue signal for shifting set-point.

Separately supplied accessories

- Outdoor air temperature probe for set-point compensation.
- Water filter.
- Rubber anti-vibration mounts.
- Remote keypad with LCD display.
- Clock board.
- Interfaces for serial communication with other devices.
- Serial converter (RS485/USB).



TCEEY MODEL		115	118	122	125	230	240
❶ Nominal cooling capacity	kW	13,7	16,4	20,1	23,3	26,8	36,9
❶ EER		3,26	4	3,65	3,76	3,12	3,69
❶ Absorbed power (*)	kW	4,2	4,1	5,5	6,2	8,6	10
❶ Available head of standard electric pump	kPa	89	80	73	114	107	113
❶ Available head of high head pump	kPa	164	146	163	152	129	135
❷ Sound power	dB(A)	58	58	62	63	64	67
❷ Silenced setup sound power	dB(A)	53	53	57	58	59	62
Scroll/ step compressors	n.	1/1	1/1	1/1	1/1	2/2	2/2
Circuits	n.	1	1	1	1	1	1
Electrical supply	V-ph-Hz	400-3+N-50	400-3+N-50	400-3+N-50	400-3+N-50	400-3+N-50	400-3+N-50
DIMENSIONS AND WEIGHTS		115	118	122	125	230	240
L - Width	mm	700	700	700	700	700	700
H - Height	mm	1140	1140	1140	1140	1140	1140
P - Depth	mm	560	560	780	780	780	780
❸ Weight	kg	166	166	191	214	234	251

Data at the following conditions:

- ❶ Chilled water: 12/7°C - Condensing temperature: 50°C (dew point)
 - ❷ Sound power level in dB(A) based on measurements carried out in accordance with regulation UNI EN ISO 9614
 - ❸ Weight refers to the most complete setup
- (*) Unit without electric pumps.

Y-Flow E

TCEEBY 245÷4360

Cooling capacity: 39.8-320.9 kW



• Built-in MASTER/ SLAVE control

Cooling only condenserless units to couple with remote condensers. Range with scroll hermetic compressors and R410A refrigerant gas.

Construction features

- Compressor: hermetic rotary scroll complete with thermal protection and crankcase heater.
- Water side heat exchanger: adequately insulated stainless steel plates, complete with antifreeze heater and water flow differential pressure switch.
- Control: microprocessor electronic control, with Adaptive Function Plus logic.
- Structure: made of galvanised and painted steel plate with polyester powder coating.
- The unit is also complete with:
 - compressor circuit breaker switches;
 - display of cooling circuit high and low pressure;
 - Master/Slave control up to 4 units in parallel;
 - clock board;
 - 0-10V analogue signal for condensing control from external device.

Models

- TCEEBY: unit designed for cooling only.

Factory fitted accessories

- PUMP primary side (user): pump unit complete with single or double electric circulation pump, membrane expansion tank, safety valve, water fill/drain valve, manual air vent valve and pressure gauge. The electric pumps are available with low or high head.
- VPF control.
- Inverter pump control for unit start-up.
- Power factor correction capacitors ($\cos\phi > 0.94$)
- Cooling circuit high and low pressure gauges.
- Power factor correction capacitors.
- Soft start device.
- Forced limit of power consumption.
- Energy parameter measuring device.
- Control of min/max power supply voltage.
- Double safety valves.
- Silenced set up.
- Interfaces for serial communication with other devices.
- Digital input for double set-point.
- 4-20 mA analogue signal for shifting set-point.
- Rubber anti-vibration mounts (or spring-operated for models 4180-4360) supplied unassembled.

Separately supplied accessories

- Outdoor air temperature probe for set-point compensation.
- Water filter.
- Rubber anti-vibration mounts.
- Clock board.
- Remote keypad with display.
- Serial converter (RS485/USB).



TCEEBY MODEL		245	250	260	270	275	290	2100	2115	2130	2145	2165	2185	
①	Nominal cooling capacity	kW	39,8	47,3	53,6	61,3	67,9	80,6	91,7	103,4	115	128,2	145,7	162,3
①	EER		3,29	3,38	3,3	3,76	3,39	3,49	3,38	3,34	3,29	3,34	3,26	3,19
①	Absorbed power (*)	kW	12,1	14	16,2	18,2	20	23,1	27,1	31	35	38,4	44,7	50,8
①	Available head of standard electric pump	kPa	116	108	134	94	84	86	117	119	133	117	119	106
①	Available head of high head pump	kPa	182	187	171	185	177	180	169	178	190	176	177	172
②	Sound power	dB(A)	67	67	68	68	69	70	71	72	73	74	74	75
②	Silenced setup sound power	dB(A)	63	63	64	64	65	66	67	68	69	70	70	71
	Scroll/ step compressors	n.	2/2	2/2	2/2	2/2	2/2	2/2	2/2	2/2	2/2	2/2	2/2	2/2
	Circuits	n.	1	1	1	1	1	1	1	1	1	1	1	1
	Electrical supply	V-ph-Hz	400-3+N-50	400-3+N-50	400-3+N-50	400-3+N-50	400-3+N-50	400-3+N-50	400-3+N-50	400-3+N-50	400-3+N-50	400-3+N-50	400-3+N-50	400-3+N-50
DIMENSIONS AND WEIGHTS			245	250	260	270	275	290	2100	2115	2130	2145	2165	2185
	L - Width	mm	1020	1020	1020	1020	1020	1020	1270	1270	1270	1270	1270	1270
	W - Width (PUMP setup)	mm	1250	1250	1250	1250	1250	1250	1500	1500	1500	1500	1500	1500
	H - Height	mm	1470	1470	1470	1470	1470	1470	1620	1620	1620	1620	1620	1620
	P - Depth	mm	870	870	870	870	870	870	870	870	870	870	870	870
③	Weight	kg	380	390	390	400	400	420	660	670	690	710	720	720

TCEEBY MODEL			2185	4180	4205	4235	4260	4290	4330
①	Nominal cooling capacity	kW	162,3	161,2	182,9	205	229,4	253,8	287,4
①	EER		3,19	3,53	3,5	3,48	3,49	3,5	3,42
①	Absorbed power (*)	kW	50,8	45,7	52,3	58,9	65,8	72,6	84
①	Available head of standard electric pump	kPa	106	140	132	114	117	111	136
①	Available head of high head pump	kPa	172	195	200	196	240	273	241
②	Sound power	dB(A)	75	77	77	78	79	80	81
②	Silenced setup sound power	dB(A)	71	75	75	76	77	78	79
	Scroll/ step compressors	n.	2/2	4/4	4/4	4/4	4/4	4/4	4/4
	Circuits	n.	1	2	2	2	2	2	2
	Electrical supply	V-ph-Hz	400-3+N-50	400-3-50	400-3-50	400-3-50	400-3-50	400-3-50	400-3-50
DIMENSIONS AND WEIGHTS			2185	4180	4205	4235	4260	4290	4330
	L - Width	mm	1270	2600	2600	2600	2600	2600	2600
	W - Width (PUMP setup)	mm	1500	3734	3734	3734	3734	3734	3734
	H - Height	mm	1620	1860	1860	1860	1860	1860	1860
	P - Depth	mm	870	870	870	870	870	870	870
③	Weight	kg	720	1310	1370	1390	1410	1440	1460

Data at the following conditions:

- ① Chilled water: 12/7°C - Condensing temperature: 50°C (dew point)
 - ② Sound power level in dB(A) based on measurements carried out in accordance with regulation UNI EN ISO 9614
 - ③ Weight referred to the unit without load and not accessorised.
- (*) Unit without electric pumps.

Recommended combinations with CCAMY condensers for TCEEBY models 4180-4360

TCEEBY MODEL	4180	4205	4235	4260	4290	4330
CCAMY MODEL	CCAMY 290	CCAMY 2110	CCAMY 2115	CCAMY 2130	CCAMY 2145	CCAMY 2165
	CCAMY 290	CCAMY 2110	CCAMY 2115	CCAMY 2130	CCAMY 2145	CCAMY 2165

SEASONAL ENERGY PERFORMANCE			4180	4205	4235	4260	4290	4330
TCEEBY + CCAMBY MODEL SEASONAL PERFORMANCE IN COOLING MODE								
①	P _{designc} (EN 14825)	kW	160,6	182,2	204,2	228,5	252,9	286,3
①	SEER (EN 14825)		4,19	4,22	4,24	4,25	4,26	4,27
②	η _{s,c}	%	165	166	167	167	167	168
TCEEBY + CCAMSY MODEL SEASONAL PERFORMANCE IN COOLING MODE								
①	P _{designc} (EN 14825)	kW	160,6	182,2	204,2	228,5	252,9	286,3
①	SEER (EN 14825)		4,18	4,21	4,23	4,22	4,24	4,24
②	η _{s,c}	%	164	165	166	166	167	167
TCEEBY + CCAMQY MODEL SEASONAL PERFORMANCE IN COOLING MODE								
①	P _{designc} (EN 14825)	kW	160,6	182,2	204,2	228,5	252,9	286,3
①	SEER (EN 14825)		4,14	4,18	4,19	4,2	4,23	4,22
②	η _{s,c}	%	163	164	165	165	166	166

- ① Low temperature application (7°C)
- ② Seasonal energy efficiency: low temperature cooling (EU Regulation 2016/2281)

Z-Flow E

TCEVZ 1200÷31630

Cooling capacity: 171.9-1,424.8 kW



TCEVBZ 2630

- **Efficient condenserless unit in R134a**
- **33 sizes in standard and soundproofed versions**
- **Wide range of standard equipment**
- **Integrated MASTER/SLAVE control**

Cooling only condenserless units. Range with semi-hermetic screw compressors and R134a refrigerant gas.

Construction features

- Compressor: high energy efficiency semi-hermetic screw compressor, with star-delta or part-winding start up (depending on models) and complete with integral protection, casing heater and refrigerant gas outlet piping shut-off valve.
- Electronic expansion valve: as standard on all models.
- Water side heat exchanger (evaporator): dry expansion shell and tube exchanger with counterflow heat exchange, complete with closed cell polyurethane foam rubber insulation, water flow differential pressure switch and Victaulic fittings.
- Control: microprocessor electronic control.
- Structure: made of galvanised and painted steel plate with polyester powder coating.
- The unit is also complete with:
 - clock board;
 - display of cooling circuit high/low pressure;
 - Master/Slave control up to 4 units in parallel.

Versions

- B -Standard version (TCEVBZ).
- I -Soundproofed version with soundproofing compressor lining (TCEVIZ).

Models

- TCEVBZ: unit designed for cooling only.
- TCEVIZ: soundproofed unit designed for cooling only.

Factory fitted accessories

- VPF control.
- Power factor correction capacitors ($\cos\phi > 0.94$).
- Circuit breaker switches.
- Forced limit of power consumption.
- Soft starter.
- Inlet compressor shut-off valves
- Linear capacity control compressors (50-100 % for each compressor).
- Evaporator antifreeze heater.
- Digital input for double set-point.
- Compressor oil level sensor.
- Control of min/max power supply voltage.
- 4-20 mA analogue signal for shifting set-point.
- Interfaces for serial communication with other devices.
- Spring anti-vibration mounts.
- Rubber anti-vibration mounts.

Separately supplied accessories

- Remote keypad with display.
- Rhoss supervisors for unit monitoring and remote management.
- Rhoss sequencer for integrated management of multiple chillers.



TCEVBZ-TCEVIZ MODEL		1200	1230	1280	1310	1350	1410	1460	1530	1590	
①	Nominal cooling capacity	kW	171,9	190,8	238,1	260,4	300,6	346,2	399,7	446,4	508,9
①	E.E.R.		3,4	3,28	3,3	3,3	3,41	3,3	3,3	3,3	3,4
①	Absorbed power	kW	50,5	58,1	72,2	79	88,1	104	122,2	135,3	149,7
②	Sound power	dB(A)	94	94	97	97	97	97	97	98	98
②	Sound power	dB(A)	92	92	95	95	95	95	95	96	96
	Screw/step compressor	n.	1/3	1/3	1/3	1/3	1/3	1/3	1/3	1/3	1/3
	Circuits	n.	1	1	1	1	1	1	1	1	1
	Electrical supply	V-ph-Hz	400-3-50	400-3-50	400-3-50	400-3-50	400-3-50	400-3-50	400-3-50	400-3-50	400-3-50
TCEVBZ DIMENSIONS AND WEIGHTS		1200	1230	1280	1310	1350	1410	1460	1530	1590	
	L - Width	mm	3470	3450	3450	3450	3500	3500	3480	3490	3500
	H - Height	mm	1580	1580	1580	1580	1660	1660	1660	1760	1760
	P - Depth	mm	1000	1000	1000	1000	1000	1000	1000	1000	1000
③	TCEVBZ Weight	kg	1078	1093	1410	1414	1557	2032	2038	2252	2281
③	TCEVIZ Weight	kg	1333	1348	1665	1669	1812	2287	2293	2507	2536

TCEVBZ-TCEVIZ MODEL		2400	2420	2440	2510	2560	2600	2630	2680	2710	
①	Nominal cooling capacity	kW	335,8	356,6	372,1	431,9	473,4	506,4	529,3	581,4	614,1
①	E.E.R.		3,33	3,29	3,22	3,31	3,28	3,34	3,34	3,46	3,48
①	Absorbed power	kW	100,7	108,3	115,7	130,6	144,4	151,5	158,4	168	176,6
②	Sound power	dB(A)	97	97	97	99	99	99	99	99	99
②	Sound power	dB(A)	95	95	95	97	97	97	97	97	97
	Screw/step compressor	n.	2/6	2/6	2/6	2/6	2/6	2/6	2/6	2/6	2/6
	Circuits	n.	2	2	2	2	2	2	2	2	2
	Electrical supply	V-ph-Hz	400-3-50	400-3-50	400-3-50	400-3-50	400-3-50	400-3-50	400-3-50	400-3-50	400-3-50
TCEVBZ DIMENSIONS AND WEIGHTS		2400	2420	2440	2510	2560	2600	2630	2680	2710	
	L - Width	mm	3780	3830	3850	4040	4040	4040	4040	4040	4040
	H - Height	mm	1420	1420	1420	1610	1610	1610	1610	1610	1610
	P - Depth	mm	1300	1300	1300	1300	1300	1300	1300	1300	1300
③	TCEVBZ Weight	kg	1797	1811	1819	2311	2629	2637	2638	2698	2733
③	TCEVIZ Weight	kg	2227	2241	2249	2741	3059	3067	3068	3128	3163

TCEVBZ-TCEVIZ MODEL		2750	2790	2880	2930	21030	21110	21180	21260	
①	Nominal cooling capacity	kW	647,8	681,6	753,9	801,4	896,1	959,4	1.027,80	1.101,50
①	E.E.R.		3,37	3,28	3,33	3,28	3,47	3,54	3,6	3,68
①	Absorbed power	kW	192,1	207,6	226,5	244,4	257,9	271	285,5	299,4
②	Sound power	dB(A)	99	99	99	99	99	99	99	99
②	Sound power	dB(A)	97	97	97	97	97	97	97	97
	Screw/step compressor	n.	2/6	2/6	2/6	2/6	2/6	2/6	2/6	2/6
	Circuits	n.	2	2	2	2	2	2	2	2
	Electrical supply	V-ph-Hz	400-3-50	400-3-50	400-3-50	400-3-50	400-3-50	400-3-50	400-3-50	400-3-50
TCEVBZ DIMENSIONS AND WEIGHTS		2750	2790	2880	2930	21030	21110	21180	21260	
	L - Width	mm	4120	4000	4000	4000	4000	4000	4000	4000
	H - Height	mm	1610	1480	1560	1560	1600	1600	1600	1600
	P - Depth	mm	1300	1300	1300	1300	1300	1300	1300	1300
③	TCEVBZ Weight	kg	3176	3631	3844	3859	3936	3993	4024	4044
③	TCEVIZ Weight	kg	3606	4061	4272	4289	4366	4423	4454	4474

TCEVBZ-TCEVIZ MODEL		31300	31350	31390	31460	31520	31590	31630	
①	Nominal cooling capacity	kW	1.129,60	1.178,30	1.227,00	1.287,50	1.340,10	1.388,50	1.424,80
①	E.E.R.		3,6	3,55	3,51	3,51	3,52	3,53	3,51
①	Absorbed power	kW	314,1	331,8	349,5	367,1	380,4	393,4	406,4
②	Sound power	dB(A)	101	101	101	102	102	102	102
②	Sound power	dB(A)	99	99	99	100	100	100	100
	Screw/step compressor	n.	3/9	3/9	3/9	3/9	3/9	3/9	3/9
	Circuits	n.	3	3	3	3	3	3	3
	Electrical supply	V-ph-Hz	400-3-50	400-3-50	400-3-50	400-3-50	400-3-50	400-3-50	400-3-50
TCEVBZ DIMENSIONS AND WEIGHTS		31300	31350	31390	31460	31520	31590	31630	
	L - Width	mm	4940	4940	4940	4940	4940	4940	4940
	H - Height	mm	1580	1580	1580	1580	1620	1620	1620
	P - Depth	mm	2100	2100	2100	2100	2100	2100	2100
③	TCEVBZ Weight	kg	5555	5570	5585	5600	5678	5710	5790
③	TCEVIZ Weight	kg	6155	6170	6185	6200	6278	6310	6390

Data at the following conditions:

- ① Chilled water: 12/7°C - Condensing temperature: 50°C (dew point).
 - ② Total sound power level in dB(A) based on measurements carried out in accordance with regulation UNI EN-ISO 9614.
 - ③ Weight without load refers to fully accessorised unit.
- TCEVIZ soundproofed version.

Compact-Y EXP SM - TXAEY 117÷130

Compact-Y EXP MD - TXAEY 133÷265

EasyPACK-I EXP - TXAIY 270÷2130

WinPACK ECO EXP - TXAEU 4140÷4330

Y-Pack EXP - TXAEY 280÷4320

WinPOWER ECO EXP - TXAEU 4370÷6660

WinPOWER EXP - TXAEY 4400÷6660

Comby-Flow EXP - TXHEY 105÷112

Y-Flow EXP - TXHEY 245÷4410



.....**EXP - POLYVALENT SYSTEMS**.....

Compact-Y EXP SM

TXAEY 117÷130

Cooling capacity: 17.7-29.1 kW - Heating capacity: 17.6-34 kW



EXPsystems - Air cooled multi-purpose ecological system with axial fans.

Range with scroll hermetic compressors and R410A refrigerant gas.

Construction features

- Compressor: scroll type, rotary, hermetic complete with thermal protection and casing heater.
- Main and secondary heat exchangers: suitably insulated stainless steel plates, complete with antifreeze heater and water flow differential pressure switch.
- Air side heat exchanger: featuring finned coil with copper pipes and aluminium fins, complete with protection grille.
- Fan: external rotor axial type electric fans equipped with internal thermal protection, accident protection grilles and proportional electronic device for continuous fan rotation speed regulation.
- Control: microprocessor electronic control with AdaptiveFunction logic.
- Structure: in galvanised and painted steel plate, complete with condensate drain pan.

Models

- TXAEY: EXPsystems unit.

PUMP set-up

- Pump unit for primary circuit complete with: circulator or electric circulation pump, membrane expansion tank, manual air vent valve and safety valve, and pressure gauge.

Factory fitted accessories

- Silenced set up.
- Unit base antifreeze heater for operation in heat pump mode at low outdoor air temperatures.
- Digital input for double set-point
- 4-20 mA analogue signal for shifting set-point.
- Pre-painted copper/coils or copper/copper coils.

Separately supplied accessories

- Rubber anti-vibration mounts.
- Water filter.
- Remote keypad with display.
- Clock board.
- Interfaces for serial communication with other devices.
- Serial converter (RS485/USB).
- Rhoss supervisors for unit monitoring and remote management.



TXAEY MODEL		117	124	130
COOLING OPERATIONS (AUTOMATIC 1 MODE)				
1 Nominal cooling capacity	kW	17,7	24	29,1
1 Absorbed power	kW	6,6	9,4	11,8
E.E.R.		2,7	2,55	2,47
COOLING OPERATIONS + TOTAL RECOVERY (AUTOMATIC 2 MODE)				
4 Nominal cooling capacity	kW	16,3	23,6	28,1
4 Recovery heating capacity	kW	20,5	29,9	36,8
T.E.R.		7,98	7,7	6,93
HEATING OPERATIONS (MODE SELECT 1-2 AUTOMATIC 3)				
2 Nominal heating capacity	kW	17,6	25,7	34
3 Heating capacity	kW	18,3	26,8	35,4
2 Absorbed power	kW	6,2	9,1	11,3
C.O.P.		2,83	2,84	3,02
TXAEY MODEL				
5 Sound pressure	dB(A)	50	52	53
5 Silenced setup sound pressure	dB(A)	46	49	50
Scroll/step compressor	n.	1/1	1/1	1/1
Circuits	no.	1	1	1
1 Available head of standard electric pump	kPa	130	131	112
Electrical supply	V-ph-Hz	400-3+N-50	400-3+N-50	400-3+N-50
DIMENSIONS AND WEIGHTS				
L - Width	mm	1522	1522	1822
H - Height	mm	1090	1280	1510
P - Depth	mm	580	600	695
TXAEY weight	kg	220	280	370

Data at the following conditions:

- 1 Air: 35°C - Water: 12/7°C.
- 2 Air: 7°C D.B. - 6°C W.B. - Water: 40/45°C.
- 3 Air: 7°C D.B. - 6°C W.B. - Water: 30/35°C.
- 4 Evaporator water: 12/7°C. 40/45°C recovery water.
- 5 In open field (Q = 2) at 5 m from the unit.
Performance according to EN 14511. Setup with electric pump.
T.E.R.: Total efficiency ratio

SEASONAL ENERGY PERFORMANCE		117	124	130
TXAEY MODEL SEASONAL PERFORMANCE IN HEATING MODE				
3 Pdesignh (EN 14825)	kW	19	27	36
3 SCOP (EN 14825)		3,23	3,24	3,28
4 ηs	%	126	127	128
4 Energy class		A+	A+	A+

- 3 In Average climatic conditions, low temperature application (35°C)
- 4 Seasonal energy efficiency: low temperature heating in Average climate (EU Regulations No.811/2013 and No.813/2013)

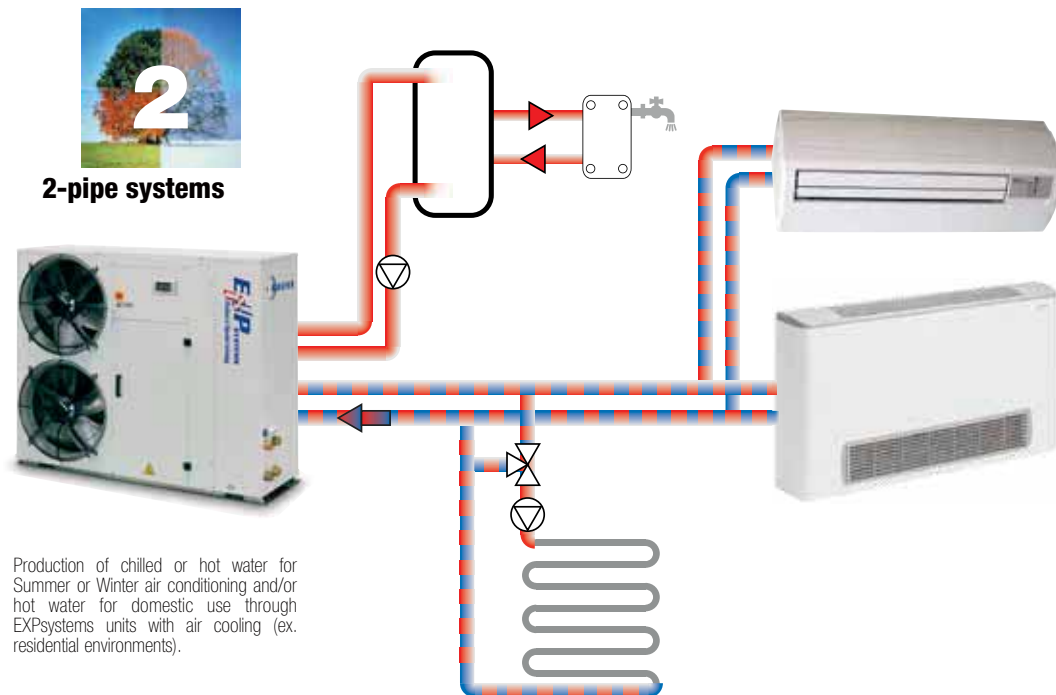

Compact-Y EXP MD

TXAEY 133÷265

Cooling capacity: 33.8-61.6 kW - Heating capacity: 39.4-68.3 kW



EXPsystems - Air cooled multi-purpose ecological system with axial fans.

Range with scroll hermetic compressors and R410A refrigerant gas.

Construction features

- Compressor: scroll type, rotary, hermetic complete with thermal protection and casing heater.
- Main and secondary heat exchangers: suitably insulated stainless steel plates, complete with antifreeze heater and water flow differential pressure switch.
- Air side heat exchanger: featuring finned coil with copper pipes and aluminium fins, complete with protection grille.
- Fan: external rotor axial type electric fans equipped with internal thermal protection, accident protection grilles and proportional electronic device for continuous fan rotation speed regulation.
- Control: microprocessor electronic control with AdaptiveFunction logic.
- Structure: made of galvanised and painted steel plate.
- The unit is also complete with:
 - display of cooling circuit high and low pressure;
 - clock board.

Models

- TXAEY: EXPsystems base unit.

Factory fitted accessories

- PUMP (only for main circuit) with single or double electric pump, including an automatic pump in standby (mod. 245-265) complete with expansion tank, air vent valves, safety valve and water side pressure gauge.
The electric pumps are available in the low or high pressure head versions.
- TANK&PUMP (only for main circuit) with inertial buffer tank and single or double electric pump, including an automatic pump in standby (mod. 245-265), complete with expansion tank, air vent valves, safety valve and water side pressure gauge.
The electric pumps are available in the low or high pressure head versions.
- Silenced set up.
- Cooling circuit high and low pressure gauges.
- Antifreeze heater for buffer tank and electric pumps.
- Digital input for double set-point
- 4-20mA analogue signal for shifting set-point.
- Pre-painted copper/coils or copper/copper coils.

Accessories supplied loose

- Rubber anti-vibration mounts.
- Water filter.
- Remote keypad with display.
- Interfaces for serial communication with other devices.
- Serial converter (RS485/USB).
- Rhoss supervisors for unit monitoring and remote management.



TXAEY MODEL		133	245	250	260	265
COOLING OPERATIONS (AUTOMATIC 1 MODE)						
① Nominal cooling capacity	kW	33,8	42,4	50,3	57,9	61,6
① Absorbed power	kW	13,5	17	18,8	21,9	24,4
E.E.R.		2,5	2,49	2,68	2,64	2,54
COOLING OPERATIONS + TOTAL RECOVERY (AUTOMATIC 2 MODE)						
③ Nominal cooling capacity	kW	32,8	41	49,7	54,9	62,4
③ Recovery heating capacity	kW	44,5	54,7	65,3	72,2	81,5
T.E.R.		6,57	6,88	7,26	7,28	7,42
HEATING OPERATIONS (MODE SELECT 1-2 AUTOMATIC 3)						
② Nominal heating capacity	kW	39,4	48,1	56,2	62,5	68,3
② Absorbed power	kW	13,6	16,8	18,9	20,9	23,7
C.O.P.		2,9	2,85	2,97	3	2,88
TXAEY MODEL						
④ Sound pressure	dB(A)	54	56	56	57	57
④ Silenced setup sound pressure	dB(A)	51	53	53	54	54
Scroll/step compressor	n.	1/1	2/1	2/1	2/1	2/1
Circuits	n.	1	1	1	1	1
Electrical supply	V-ph-Hz	400-3+N-50	400-3+N-50	400-3+N-50	400-3+N-50	400-3+N-50
DIMENSIONS AND WEIGHTS		133	245	250	260	265
L - Width	mm	1660	2315	2315	2315	2315
H - Height	mm	1570	1570	1570	1570	1570
P - Depth	mm	1000	1000	1000	1000	1000
TXAEY weight	kg	470	735	775	795	825

Data at the following conditions:

- ① Air: 35°C - Water: 12/7°C.
- ② Air: 7°C D.B. - 6°C W.B. - Water: 40/45°C.
- ③ Evaporator water: 12/7°C. 40/45°C recovery water.
- ④ In open field (Q = 2) at 5 m from the unit.
Performance according to EN 14511.
T.E.R.: Total efficiency ratio

SEASONAL ENERGY PERFORMANCE		133	245	250	260	265
TXAEY MODEL SEASONAL PERFORMANCE IN HEATING MODE						
③ P _{designh} (EN 14825)	kW	39	48	56	62	68
③ SCOP (EN 14825)		3,28	3,72	3,74	3,79	3,73
④ η _s	%	128	146	147	149	146
④ Energy class		A+	A+	A+	A+	A+

- ③ In Average climatic conditions, low temperature application (35°C)
- ④ Seasonal energy efficiency: low temperature heating in Average climate (EU Regulations No.811/2013 and No.813/2013)

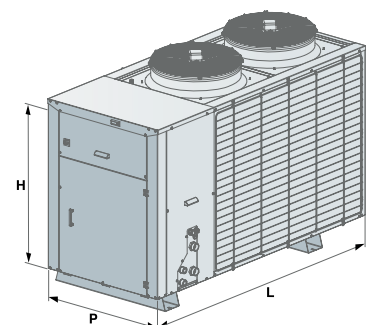

EasyPACK-I EXP

TXAIY 270÷2130

Cooling capacity: 64.4-125.9 kW - Heating capacity: 71-133.2 kW

INVERTER



- Multi-purpose units with inverter compressors
- TER up to 7.62
- Extended operating limits
- Units for systems with 2, 4 and 6 pipes
- Integrated MASTER/SLAVE control



TXAIY 2130 with coil protection metal filters accessory

TXAIY 2100 with coil protection metal filters accessory

EXPsystems - Air cooled multi-purpose ecological system with axial fans.

Range with scroll hermetic compressors, DC Inverter and R410A refrigerant gas.

Construction features

- Compressor: scroll type, rotary, hermetic and with Inverter actuation (1+i) complete with thermal protection and casing heater.
- Continuous regulation with high efficiency at partial loads.
- Main and secondary heat exchangers: crossed flow stainless steel plate exchangers, complete with antifreeze heater, closed cell polyurethane foam rubber insulation and water flow differential pressure switch.
- Air side heat exchanger: finned coil with copper pipes and aluminium fins.
- Fan: external rotor axial type electric fans equipped with internal thermal protection and accident protection grilles. The electric fans, based on the sizes, are EC fans or fitted with a proportional electronic device for continuous regulation of the rotation speed.
- Control: microprocessor electronic control with Adaptive Function Plus logic.
- Structure: made of galvanised and painted steel plate with polyester powder coating.
- The unit is also complete with:
 - compressor and fan circuit breaker switches;
 - electronic expansion valve;
 - display of cooling circuit high/low pressure;
 - master/slave control up to 4 units in parallel;
 - clock board;
 - control of Variable Primary Flow (VPF_R).

Versions

- T - High efficiency version.
- Q - Super silenced version complete with compressor technical compartment soundproofing and reduced speed fans.

Models

- TXAIY: EXPsystems unit.
- TXAIQY: super silenced EXPsystems unit.

Factory fitted accessories

- PUMP with single or double electric pump, one of which automatic in standby. The electric pumps are available in the low or high head versions.
- TANK&PUMP with 230 - 440 litre integrated buffer tank (depending on the sizes) and single or double electric pump, complete with expansion tank, air vent valves, safety valve and water side pressure gauge.
- Inverter pump control for unit start-up.
- Desuperheater.
- Condensing control with fans with EC motor (standard in sizes 270-2100).
- Condensing control with over-pressure fans (T version only)
- Power factor correction capacitors ($\cos\phi > 0.94$).
- Forced limit of power consumption.
- Forced noise limit.
- Energy parameter measuring device.
- Optimised energy efficiency.
- Soft starter.
- Technical compressor compartment soundproofing.
- Compressor soundproof enclosures.
- Cooling circuit outlet and inlet valves.
- Refrigerant leak detector.
- Cooling circuit high and low pressure gauges.
- Double safety valves.
- Metal filters or coil protection nets.
- Copper/copper or copper/pre-painted aluminium coils.
- Control of min/max power supply voltage.
- Digital input for double set-point.
- 4-20 mA analogue signal for shifting set-point.
- Electrical panel heater, buffer tank, electric pumps and heat exchangers for heat recovery, if applicable.
- Interfaces for serial communication with other devices.
- Rubber anti-vibration mounts.

Separately supplied accessories

- Remote keypad with display.
- Thermostat with display.
- Rhoss supervisors for unit monitoring and remote management.
- Rhoss sequencer for integrated management of multiple chillers.



TXAIQY MODEL		270	280	290	2100	2115	2130
COOLING OPERATIONS (AUTOMATIC 1 MODE)							
① Nominal cooling capacity	kW	66,6	78,8	86,2	93	112,3	125,9
① Absorbed power	kW	22,2	26,53	29,02	32,52	37,81	42,11
E.E.R.		3	2,97	2,97	2,86	2,97	2,99
COOLING OPERATIONS + TOTAL RECOVERY (AUTOMATIC 2 MODE)							
③ Nominal cooling capacity	kW	68,5	84,3	87	96,1	114,9	128,1
③ Recovery heating capacity	kW	88,4	109,1	112,4	124,3	148,4	164,6
T.E.R.		7,53	7,43	7,52	7,47	7,49	7,62
HEATING OPERATIONS (MODE SELECT 1-2 AUTOMATIC 3)							
② Nominal heating capacity	kW	72,8	85,1	92,2	100,2	120,3	133,2
② Absorbed power	kW	21,89	25,63	27,52	30,09	36,23	41,11
C.O.P.		3,33	3,32	3,35	3,33	3,32	3,24
TXAIQY MODEL							
COOLING OPERATIONS (AUTOMATIC 1 MODE)							
① Nominal cooling capacity	kW	64,4	77,2	83,7	89,4	107,9	122,2
① Absorbed power	kW	22,92	27,18	29,68	33,48	38,54	42,88
E.E.R.		2,81	2,84	2,82	2,67	2,8	2,85
COOLING OPERATIONS + TOTAL RECOVERY (AUTOMATIC 2 MODE)							
③ Nominal cooling capacity	kW	68,5	84,3	87	96,1	114,9	128,1
③ Recovery heating capacity	kW	88,4	109,1	112,4	124,3	148,4	164,6
T.E.R.		7,53	7,43	7,52	7,47	7,49	7,62
HEATING OPERATIONS (MODE SELECT 1-2 AUTOMATIC 3)							
② Nominal heating capacity	kW	71	83,2	90,3	98,4	117,2	130,5
② Absorbed power	kW	21,52	25,14	27,28	29,82	36,06	40,78
C.O.P.		3,3	3,31	3,31	3,3	3,25	3,2
TXAIQY-TXAIQY MODEL							
④ TXAIQY sound pressure	dB(A)	52	53	53	53	56	56
④ TXAIQY sound pressure	dB(A)	45	46	46	46	50	50
⑤ TXAIQY sound power	dB(A)	84	85	85	85	88	88
⑤ TXAIQY sound power	dB(A)	77	77,5	77,5	77,5	82	82
Scroll/step compressor	n.			1+i / regolazione continua			
Circuits	n.	2	2	2	2	2	2
Electrical supply	V-ph-Hz	400-3+N-50	400-3+N-50	400-3+N-50	400-3+N-50	400-3+N-50	400-3+N-50
DIMENSIONS AND WEIGHTS							
L - Width	mm	3250	3250	3250	3250	3450	3450
H - Height	mm	1540	1540	1540	1540	2000	2000
P - Depth	mm	1210	1210	1210	1210	1520	1520
⑥ TXAIQY weight	kg	1060	1085	1095	1105	1435	1455
⑥ TXAIQY weight	kg	1095	1120	1130	1140	1485	1505

Data at the following conditions:

- ① Air: 35°C - Water: 12/7°C.
 - ② Air: 7°C D.B. - 6°C W.B. - Water: 40/45°C.
 - ③ Evaporator water: 12/7°C. Recovery output water 45°C - Nominal flow rate.
 - ④ In open field (Q = 2) at 10 m from the unit.
 - ⑤ Total sound power level in dB(A) based on measurements carried out in accordance with regulation UNI EN-ISO 9614.
 - ⑥ Weight referred to the unit without load and not accessorised.
- Performance according to EN 14511.
T.E.R.: Total efficiency ratio

SEASONAL ENERGY PERFORMANCE		270	280	290	2100	2115	2130
TXAIQY MODEL SEASONAL PERFORMANCE IN HEATING MODE							
③ Pdesignh (EN 14825)	kW	70	84	86	94	113	125
③ SCOP (EN 14825)		3,93	3,97	3,97	3,99	3,99	3,88
④ ηs	%	154	156	156	157	157	152
④ Energy class		A++					
TXAIQY MODEL SEASONAL PERFORMANCE IN HEATING MODE							
③ Pdesignh (EN 14825)	kW	68	80	84	92	109	122
③ SCOP (EN 14825)		4	4,04	4,01	3,93	3,9	3,84
④ ηs	%	157	159	157	154	153	151
④ Energy class		A++					

- ③ In Average climatic conditions, low temperature application (35°C)
- ④ Seasonal energy efficiency: low temperature heating in Average climate (EU Regulations No.811/2013 and No.813/2013)

WinPACK ECO EXP

TXAEU 4140÷4330

Cooling capacity: 135.7-333.6 kW - Heating capacity: 144.3-351.4 kW



- Multi-purpose units with TER up to 7.85
- R454B refrigerant gas
- Integrated MASTER/SLAVE control

EXPsystems - Air cooled multi-purpose ecological system with axial fans.

Range with scroll hermetic compressors and R454B refrigerant gas.

Construction features

- Compressor: scroll type, rotary, hermetic complete with thermal protection and casing heater.
- 4 capacity steps with high efficiency at partial loads.
- Main and secondary heat exchangers: crossed flow stainless steel plate exchangers, complete with antifreeze heater, closed cell polyurethane foam rubber insulation and water flow differential pressure switch.
- Air side heat exchanger: finned coil with copper pipes and aluminium fins.
- Fan: external rotor axial type electric fans equipped with internal thermal protection and accident protection grilles. The electric fans are fitted with a proportional electronic device for continuous regulation of the rotation speed.
- Control: microprocessor electronic control with Adaptive Function Plus logic.
- Structure: made of galvanised and painted steel plate with polyester powder coating.
- The unit is also complete with:
 - compressor and fan circuit breaker switches;
 - electronic expansion valve;
 - display of cooling circuit high/low pressure;
 - master/slave control up to 4 units in parallel;
 - clock board;
 - control of Variable Primary Flow (VPF_R).

Versions

- T - High efficiency version.
- Q - Super silenced version complete with compressor technical compartment soundproofing and reduced speed fans.

Models

- TXAETU: EXPsystems unit.
- TXAEQU: super silenced EXPsystems unit.

Factory fitted accessories

- PUMP with single or double electric pump, one of which automatic in standby. The electric pumps are available in the low or high head versions.
- TANK&PUMP with 440 - 700 litre integrated buffer tank (depending on the sizes) and single or double electric pump, complete with expansion tank, air vent valves, safety valve and water side pressure gauge.
- Inverter pump control for unit start-up.
- Condensing control with fans with EC motor.
- Condensing control with over-pressure fans (T version only)
- Power factor correction capacitors ($\cos\phi > 0.94$).
- Forced limit of power consumption.
- Forced noise limit.
- Energy parameter measuring device.
- Optimised energy efficiency.
- Soft starter.
- Technical compressor compartment soundproofing.
- Compressor soundproof enclosures.
- Cooling circuit outlet and inlet valves.
- Refrigerant leak detector.
- Double safety valves.
- Metal filters or coil protection nets.
- Copper/copper or copper/pre-painted aluminium coils.
- Control of min/max power supply voltage.
- Digital input for double set-point.
- 4-20 mA analogue signal for shifting set-point.
- Electrical panel resistance, buffer tank, electric pumps, if present.
- Interfaces for serial communication with other devices.
- Anti-vibration mounts.

Separately supplied accessories

- Remote keypad with display.
- Rhoss supervisors for unit monitoring and remote management.
- Rhoss sequencer for integrated management of multiple chillers.



TXAETU MODEL		4140	4160	4190	4210	4230	4260	4300	4330	
COOLING OPERATIONS (AUTOMATIC 1 MODE)										
1	Nominal cooling capacity	kW	141,7	157,7	189,7	213,6	232,9	263,7	298,6	333,6
1	Absorbed power	kW	47,9	54,4	63,4	74,2	82,9	90,9	103	117,5
	E.E.R.		2,96	2,9	2,99	2,88	2,81	2,9	2,9	2,84
COOLING OPERATIONS + TOTAL RECOVERY (AUTOMATIC 2 MODE)										
3	Nominal cooling capacity	kW	143,4	159,4	191,8	215,3	235,2	266,1	301,7	336,4
3	Recovery heating capacity	kW	183,3	204,4	244,4	275,4	301,4	339,5	385,5	430,5
	T.E.R.		7,8	7,68	7,85	7,78	7,69	7,84	7,76	7,73
HEATING OPERATIONS (MODE SELECT 1-2 AUTOMATIC 3)										
2	Nominal heating capacity	kW	147,3	163,3	197,3	224,3	244,3	271,3	313,4	351,4
2	Absorbed power	kW	45	50,4	61,1	68,6	75,2	84,3	96,1	109,8
	C.O.P.		3,27	3,24	3,23	3,27	3,25	3,22	3,26	3,2
TXAEQU MODEL										
COOLING OPERATIONS (AUTOMATIC 1 MODE)										
1	Nominal cooling capacity	kW	135,7	149,7	181,7	202,7	219,7	255,7	287,7	323,6
1	Absorbed power	kW	51	56,9	64	75,9	85,5	89,4	102	112,8
	E.E.R.		2,66	2,63	2,84	2,67	2,57	2,86	2,82	2,87
COOLING OPERATIONS + TOTAL RECOVERY (AUTOMATIC 2 MODE)										
3	Nominal cooling capacity	kW	143,4	159,4	191,8	215,3	235,2	266,1	301,7	336,4
3	Recovery heating capacity	kW	183,3	204,4	244,4	275,4	301,4	339,5	385,5	430,5
	T.E.R.		7,8	7,68	7,85	7,78	7,69	7,84	7,76	7,73
HEATING OPERATIONS (MODE SELECT 1-2 AUTOMATIC 3)										
2	Nominal heating capacity	kW	144,3	159,4	194,3	219,3	238,3	268,3	308,4	347,4
2	Absorbed power	kW	44,3	49,3	58,9	66,5	73,5	81,3	92,9	105,3
	C.O.P.		3,26	3,23	3,3	3,3	3,24	3,3	3,32	3,3
TXAETU-TXAEQU MODEL										
4	TXAETU sound pressure	dB(A)	54	55	57	57	58	60	61	62
4	TXAEQU sound pressure	dB(A)	48	49	51	51	52	54	55	56
5	TXAETU sound power	dB(A)	86	87	89	89	90	92	93	94
5	TXAEQU sound power	dB(A)	80	81	83	83	84	86	87	88
	Scroll/step compressor	n.	4/3	4/3	4/3	4/3	4/3	4/3	4/3	4/3
	Circuits	n.	2	2	2	2	2	2	2	2
	Electrical supply	V-ph-Hz	400-3-50	400-3-50	400-3-50	400-3-50	400-3-50	400-3-50	400-3-50	400-3-50
DIMENSIONS AND WEIGHTS										
	L - Width	mm	3450	3450	4800	4800	4800	4800	5300	5300
	H - Height	mm	2000	2000	2030	2030	2030	2030	2030	2030
	P - Depth	mm	1520	1520	2090	2090	2090	2090	2090	2090
6	TXAETU weight	kg	1670	1685	2405	2550	2610	2750	3030	3250
6	TXAEQU weight	kg	1735	1750	2495	2640	2700	2840	3120	3340

Data at the following conditions:

- 1 Air: 35°C - Water: 12/7°C.
- 2 Air: 7°C D.B. - 6°C W.B. - Water: 40/45°C.
- 3 Evaporator water: 12/7°C. 40/45°C recovery water.
- 4 In open field (Q = 2) at 10 m from the unit.
- 5 Total sound power level in dB(A) based on measurements carried out in accordance with regulation UNI EN-ISO 9614.
- 6 Weight referred to the unit without load and not accessorised.

Performance according to EN 14511.

T.E.R.: Total efficiency ratio

SEASONAL ENERGY PERFORMANCE		4140	4160	4190	4210	4230	4260	4300	4330	
TXAETU MODEL SEASONAL PERFORMANCE IN HEATING MODE										
3	Pdesignh (EN 14825)	kW	127	142	171	194	212	236	275	309
3	SCOP (EN 14825)		3,67	3,64	3,62	3,66	3,62	3,59	3,62	3,52
4	ηs	%	144	143	142	143	142	140	142	138
TXAEQU MODEL SEASONAL PERFORMANCE IN HEATING MODE										
3	Pdesignh (EN 14825)	kW	124	139	168	190	207	234	270	305
3	SCOP (EN 14825)		3,67	3,65	3,73	3,72	3,64	3,72	3,71	3,66
4	ηs	%	144	143	146	146	143	146	146	143

3 In Average climatic conditions, low temperature application (35°C)

4 Seasonal energy efficiency: low temperature heating in Average climate (EU Regulations No.811/2013 and No.813/2013)

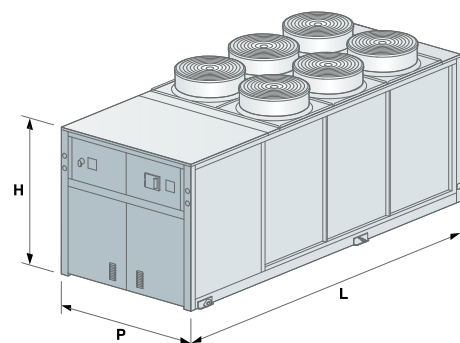

Y-Pack EXP

TXAEY 280÷4320

Cooling capacity: 80.7-332.9 kW - Heating capacity: 84.3-354.3 kW



TXAESY 4320 with coil protection nets accessory

• T.E.R. (°) up to 8.09

EXPsystems - Air cooled multi-purpose ecological system with axial fans.

Range with scroll hermetic compressors and R410A refrigerant gas.

Construction features

- Compressor: scroll type, rotary, hermetic complete with thermal protection and casing heater.
- Main and secondary heat exchangers: crossed flow stainless steel plate exchangers, complete with antifreeze heater, closed cell polyurethane foam rubber insulation and water flow differential pressure switch.
- Air side heat exchanger: finned coil with copper pipes and aluminium fins.
- Fan: electric helical fans with EC motor with continuous regulation of rotation speed, equipped with internal thermal protection and complete with accident protection grilles.
- Control: microprocessor electronic control with Adaptive Function Plus logic.
- Structure: made of galvanised and painted steel plate with polyester powder coating.
- The unit is also complete with:
 - fan and compressor circuit breaker switches;
 - clock board;
 - electronic expansion valve;
 - display of cooling circuit high/low pressure;
 - master/slave control up to 4 units in parallel.

Versions

- • T - High efficiency version with fans with EC motor.
- S - Silenced version complete with compressor technical compartment soundproofing, reduced speed fans with EC motor.

Models

- TXAEY: EXPsystems unit.
- TXAESY: silenced EXPsystems unit.

Factory fitted accessories

- PUMP (for main and secondary circuit) with single or double electric pump, including an automatic pump in standby. The electric pumps are available in the low or high head versions.
- TANK&PUMP (for main circuit only) with integrated buffer tank and single or double electric pump, complete with expansion tank, air vent valves, safety valve and water side pressure gauge.
- Inverter pump control for unit start-up.
- Power factor correction capacitors ($\cos\phi > 0.94$).
- Soft starter forced limit of power consumption.
- Cooling circuit high and low pressure gauges.
- Metal filters or coil protection nets.
- Copper/copper or copper/pre-painted aluminium coils.
- Digital input for double set-point.
- 4-20 mA analogue signal for shifting set-point.
- Buffer tank antifreeze resistors and electric pumps if present.
- Interfaces for serial communication with other devices.
- Anti-vibration mounts.

Separately supplied accessories

- Remote keypad with display.
- Rhoss supervisors for unit monitoring and remote management.
- Rhoss sequencer for integrated management of multiple chillers.



TXAETY MODEL		280	2100	2130	4160	4200	4260	4320
COOLING OPERATIONS (AUTOMATIC 1 MODE)								
① Nominal cooling capacity	kW	83,7	107,6	134,6	162,5	206,2	263,1	332,9
① Absorbed power	kW	27	35,2	43,8	56,6	72,6	93,9	118,5
E.E.R.		3,1	3,06	3,07	2,87	2,84	2,8	2,81
COOLING OPERATIONS + TOTAL RECOVERY (AUTOMATIC 2 MODE)								
Nominal cooling capacity	kW	84,8	108,4	135,4	164,5	208	266,1	335,6
③ Recovery heating capacity	kW	108,3	140,4	174,5	215,6	272,9	347	441,3
③ T.E.R.		8,09	7,64	7,79	7,3	7,28	7,44	7,21
HEATING OPERATIONS (MODE SELECT 1-2 AUTOMATIC 3)								
② Nominal heating capacity	kW	86,3	111,4	139,5	171,6	227,9	282	354,3
② Absorbed power	kW	25,6	33,9	42,9	55,2	73,9	91,9	116,5
C.O.P.		3,37	3,29	3,25	3,11	3,08	3,07	3,04
TXAESY MODEL								
COOLING OPERATIONS (AUTOMATIC 1 MODE)								
① Nominal cooling capacity	kW	80,7	103,7	129,6	156,5	199,3	254,1	316
① Absorbed power	kW	27,3	35,6	44,3	57,2	73,6	94,9	119,3
E.E.R.		2,96	2,92	2,93	2,74	2,71	2,68	2,65
COOLING OPERATIONS + TOTAL RECOVERY (AUTOMATIC 2 MODE)								
③ Nominal cooling capacity	kW	84,9	108,4	135,5	164,5	208	266,2	335,7
③ Recovery heating capacity	kW	108,3	140,4	174,4	215,6	272,8	347	441,3
T.E.R.		8,09	7,64	7,8	7,3	7,28	7,44	7,21
HEATING OPERATIONS (MODE SELECT 1-2 AUTOMATIC 3)								
② Nominal heating capacity	kW	84,3	108,4	136,4	167,6	221,8	275	345,2
② Absorbed power	kW	24,6	32,5	41,1	52,9	71,1	88,5	111,8
C.O.P.		3,43	3,34	3,32	3,17	3,12	3,11	3,09
TXAETY-TXAETY MODEL								
④ TXAETY sound pressure	dB(A)	52	52	53	54	59	61	61
④ TXAESY sound pressure	dB(A)	49	49	50	51	54	57	57
⑤ TXAETY sound power	dB(A)	84	84	85	86	91	93	93
⑤ TXAESY sound power	dB(A)	81	81	82	83	86	89	89
Scroll/step compressor	n.	2/2	2/2	2/2	4/4	4/4	4/4	4/4
Circuits	n.	2	2	2	2	2	2	2
Electrical supply	V-ph-Hz	400-3+N-50	400-3+N-50	400-3+N-50	400-3+N-50	400-3+N-50	400-3+N-50	400-3+N-50
DIMENSIONS AND WEIGHTS								
L - Width	mm	2600	2600	3700	3700	4800	4800	4800
H - Height	mm	2000	2000	2000	2000	2030	2030	2030
P - Depth	mm	2090	2090	2090	2090	2090	2090	2090
⑥ TXAETY weight	kg	1650	1500	1540	2185	2565	2665	2830
⑥ TXAESY weight	kg	1635	1485	1525	2170	2550	2650	2815

Data at the following conditions:

- ① Air: 35°C - Water: 12/7°C.
- ② Air: 7°C D.B. - 6°C W.B. - Water: 40/45°C.
- ③ Evaporator water: 12/7°C. Recovery output water 45°C - Nominal flow rate.
- ④ In open field (Q = 2) at 10 m from the unit.
- ⑤ Total sound power level in dB(A) based on measurements carried out in accordance with regulation UNI EN-ISO 9614.
- ⑥ Weight referred to the unit without load and not accessorised.

Performance according to EN 14511.

T.E.R.: Total efficiency ratio

SEASONAL ENERGY PERFORMANCE		280	2100	2130	4160	4200	4260	4320
TXAETY MODEL SEASONAL PERFORMANCE IN HEATING MODE								
③ P _{designh} (EN 14825)	kW	77	98	124	153	201	252	314
③ SCOP (EN 14825)		3,99	3,85	3,81	3,46	3,41	3,36	3,36
④ η _s	%	157	151	149	136	133	132	131
TXAESY MODEL SEASONAL PERFORMANCE IN HEATING MODE								
③ P _{designh} (EN 14825)	kW	75	95	121	148	196	246	305
③ SCOP (EN 14825)		4,1	3,92	3,91	3,52	3,47	3,44	3,42
④ η _s	%	161	154	153	138	136	135	134

③ In Average climatic conditions, low temperature application (35°C)

④ Seasonal energy efficiency: low temperature heating in Average climate (EU Regulations No.811/2013 and No.813/2013)

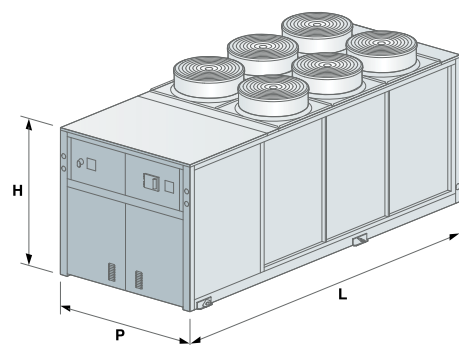

WinPOWER ECO EXP

TXAEU 4370÷6660

new

Cooling capacity: 352.7-641.5 kW - Heating capacity: 363.3-645.5 kW



- Multi-purpose units with TER up to 8
- Extended operating limits
- Units for systems with 2, 4 and 6 pipes
- SEER up to 5.29 with FIEC accessory (EC fans) and SCOP up to 3.89
- R454B eco-friendly gas



TXAETU 6660
with PTL, BFI accessory

EXPsystems - Air cooled multi-purpose ecological system with axial fans.

Range with scroll hermetic compressors and R454B refrigerant gas.

- Compressor: scroll type, rotary, hermetic complete with thermal protection and casing heater.
- Up to 6 capacity steps with high efficiency at partial loads.
- Main and secondary heat exchangers: crossed flow stainless steel plate exchangers, complete with antifreeze heater, closed cell polyurethane foam rubber insulation and water flow differential pressure switch.
- Air side heat exchanger: finned coil with copper pipes and aluminium fins.
- Fan: external rotor axial type electric fans equipped with internal thermal protection, accident protection grilles and proportional electronic device for continuous fan rotation speed adjustment.
- Control: microprocessor electronic control with Adaptive Function Plus logic.
- Structure: load-bearing structure made of galvanised and painted steel plate with polyester powder coating.
- The unit is also complete with:
 - fan and compressor thermal magnetic circuit breakers, heat exchanger antifreeze heater;
 - display of cooling circuit high and low pressure;
 - electronic expansion valve;
 - clock board;
 - Master/Slave control up to 4 units in parallel;
 - control of Variable Primary Flow (VPF_R).

Versions

- T - High efficiency version.
- Q - Super silenced version complete with compressor technical compartment soundproofing and reduced speed fans.

Models

- TXAETU: EXPsystems unit.
- TXAEQU: super silenced EXPsystems unit.

Factory fitted accessories

- PUMP with single or double electric pump, one of which automatic in standby. The electric pumps are available in the main and secondary/recovery heat exchanger low or high head set-ups.
- Inverter pump control for unit start-up.
- Desuperheater.
- Condensing control with fans with EC motor.
- Condensing control with over-pressure fans (T version only).
- Power factor correction capacitors ($\cos\phi > 0.94$).
- Forced limit of power consumption.
- Forced noise limit.
- Energy parameter measuring device.
- Soft starter.
- Compressor box and soundproofed cooling circuit.
- Compressor soundproof enclosures.
- Cooling circuit outlet valves.
- Refrigerant leak detector.
- Cooling circuit high and low pressure gauges.
- Double safety valves.
- Coil protection nets or buffer panels.
- Bottom compartment protection nets.
- Pre-painted copper/aluminium coils, copper/copper or with hydrophilic treatment.
- Digital input for double set-point.
- 4-20 mA analogue signal for shifting set-point.
- Electrical panel antifreeze heater, coil tanks, electric pumps and desuperheater, if applicable.
- Interfaces for serial communication with other devices.
- Colour touch user keypad (fitted on the machine or remotely) with 7" display.
- Spring anti-vibration mounts.
- Protective packaging.

Separately supplied accessories

- Remote keypad with display.
- Thermostat with display.
- Rhoss supervisors for unit monitoring and remote management.
- Rhoss sequencer for integrated management of multiple chillers.



TXAETU MODEL		4370	4410	4450	5490	5520	5560	6600	6630	6660
COOLING OPERATIONS (AUTOMATIC 1 MODE)										
① Nominal cooling capacity	kW	360,7	391,7	431,7	474,6	494,6	542,6	585,5	611,6	641,5
① Absorbed power	kW	110,3	125,1	137,9	151,1	159	174,5	184,1	192,9	203
E.E.R.		3,27	3,13	3,13	3,14	3,11	3,11	3,18	3,17	3,16
COOLING OPERATIONS + TOTAL RECOVERY (AUTOMATIC 2 MODE)										
③ Nominal cooling capacity	kW	346,8	346,8	346,8	459,9	480,2	533,6	571,7	599,3	635,1
③ Recovery heating capacity	kW	442,4	442,4	442,4	589,6	615,6	680,6	729,6	763,6	806,6
T.E.R.		7,89	7,89	7,89	7,7	7,7	7,86	7,85	7,92	8,02
HEATING OPERATIONS (MODE SELECT 1-2 AUTOMATIC 3)										
② Nominal heating capacity	kW	368,3	400,3	435,4	482,4	508,4	544,4	591,5	623,4	645,5
② Absorbed power	kW	110,6	121,7	133,1	145,7	154,1	165,5	179,8	189,5	196,8
C.O.P.		3,33	3,29	3,27	3,31	3,3	3,29	3,29	3,29	3,28
TXAEQU MODEL										
COOLING OPERATIONS (AUTOMATIC 1 MODE)										
① Nominal cooling capacity	kW	352,7	381,7	420,7	463,6	482,6	528,6	572,5	595,6	624,6
① Absorbed power	kW	110,6	126	140,2	152	160,3	177,4	185,3	194,6	202,1
E.E.R.		3,19	3,03	3	3,05	3,01	2,98	3,09	3,06	3,09
COOLING OPERATIONS + TOTAL RECOVERY (AUTOMATIC 2 MODE)										
③ Nominal cooling capacity	kW	346,8	382,2	427,6	459,9	480,2	533,6	571,7	599,3	635,1
③ Recovery heating capacity	kW	442,4	489,4	544,5	589,6	615,6	680,6	729,6	763,6	806,6
T.E.R.		7,89	7,78	7,96	7,7	7,7	7,86	7,85	7,92	8,02
HEATING OPERATIONS (MODE SELECT 1-2 AUTOMATIC 3)										
② Nominal heating capacity	kW	363,3	395,3	429,3	475,4	500,4	537,4	582,5	613,4	636,5
② Absorbed power	kW	106,9	118,4	129,7	141,1	149,4	161,4	174,4	184,2	191,1
C.O.P.		3,4	3,34	3,31	3,37	3,35	3,33	3,34	3,33	3,33
TXAETU-TXAEQU MODEL										
④ TXAETU sound pressure	dB(A)	62,5	63,5	63,5	64,5	64,5	64,5	65	65	66
④ TXAEQU sound pressure	dB(A)	55	55,5	55,5	56,5	56,5	56,5	57	57	57
⑤ TXAETU sound power	dB(A)	95	96	96	97	97	97	98	98	99
⑤ TXAEQU sound power	dB(A)	87	88	88	89	89	89	90	90	90
Scroll/step compressor	n.	4/4	4/4	4/4	5/5	5/5	5/5	6/6	6/6	6/6
Circuits	n.	2	2	2	2	2	2	2	2	2
Electrical supply	V-ph-Hz	400-3-50	400-3-50	400-3-50	400-3-50	400-3-50	400-3-50	400-3-50	400-3-50	400-3-50
DIMENSIONS AND WEIGHTS										
L - Width	mm	4840	4840	4840	5940	5940	5940	7100	7100	7100
H - Height	mm	2480	2480	2480	2480	2480	2480	2480	2480	2480
P - Depth	mm	2260	2260	2260	2260	2260	2260	2260	2260	2260
⑥ TXAETU weight	kg	3430	3550	3600	4310	4380	4410	5240	5310	5340
⑥ TXAEQU weight	kg	3890	4010	4060	4870	4940	4970	5910	5980	6010

Data at the following conditions:

- ① Air: 35°C - Water: 12/7°C.
- ② Air: 7°C D.B. - 6°C W.B. - Water: 40/45°C.
- ③ Evaporator water: 12/7°C. Recovery output water 45°C - Nominal flow rate.
- ④ In open field (Q = 2) at 10 m from the unit.
- ⑤ Total sound power level in dB(A) based on measurements carried out in accordance with regulation UNI EN-ISO 9614.
- ⑥ Weight refers to the unit without load.

Performance according to EN 14511.

T.E.R.: Total efficiency ratio

SEASONAL ENERGY PERFORMANCE		4370	4410	4450	5490	5520	5560	6600	6630	6660
TXAETU MODEL SEASONAL PERFORMANCE IN COOLING MODE										
① P _{designc} (EN 14825)	kW	-	-	-	-	494,6	542,6	585,5	611,6	641,5
① SEER (EN 14825)		-	-	-	-	4,81	4,79	4,93	4,89	4,84
② $\eta_{s,c}$	%	-	-	-	-	189	189	194	193	191
TXAEQU MODEL SEASONAL PERFORMANCE IN COOLING MODE										
① P _{designc} (EN 14825)	kW	-	-	-	-	482,6	528,6	572,5	595,6	624,6
① SEER (EN 14825)		-	-	-	-	4,78	4,76	4,9	4,86	4,8
② $\eta_{s,c}$	%	-	-	-	-	188	188	193	191	189
TXAETU MODEL SEASONAL PERFORMANCE IN HEATING MODE										
③ P _{designh} (EN 14825)	kW	303	331	359	398	-	-	-	-	-
③ SCOP (EN 14825)		3,78	3,77	3,75	3,78	-	-	-	-	-
④ η_s	%	148	148	147	148	-	-	-	-	-
TXAEQU MODEL SEASONAL PERFORMANCE IN HEATING MODE										
③ P _{designh} (EN 14825)	kW	298	326	354	392	-	-	-	-	-
③ SCOP (EN 14825)		3,86	3,82	3,78	3,82	-	-	-	-	-
④ η_s	%	151	150	148	150	-	-	-	-	-

① Low temperature application (7°C)

② Seasonal energy efficiency: low temperature cooling (EU Regulation 2016/2281)

③ In Average climatic conditions, low temperature application (35°C)

④ Seasonal energy efficiency: low temperature heating in Average climate (EU Regulations No.811/2013 and No.813/2013)

WinPOWER EXP

TXAEY 4400÷6660

Cooling capacity: 379.1-654.8 kW - Heating capacity: 420.9-706.2 kW



TXAESY 6580 with STE accessory and RPB coil protection nets accessory



- Multi-purpose units with TER up to 7.8
- Extended operating limits
- Units for systems with 2, 4 and 6 pipes

EXPsystems - Air cooled multi-purpose ecological system with axial fans.

Range with scroll hermetic compressors and R410A refrigerant gas.

Construction features

- Compressor: scroll type, rotary, hermetic complete with thermal protection and casing heater.
- Up to 6 capacity steps with high efficiency at partial loads.
- Main and secondary heat exchangers: crossed flow stainless steel plate exchangers, complete with antifreeze heater, closed cell polyurethane foam rubber insulation and water flow differential pressure switch.
- Air side heat exchanger: finned coil with copper pipes and aluminium fins.
- Fan: external rotor axial type electric fans, equipped with internal thermal protection, accident protection grilles and a proportional electronic device for continuous fan rotation speed regulation (T version; fans with an EC motor are standard in the Q version)
- Control: microprocessor electronic control with Adaptive Function Plus logic.
- Structure: load-bearing structure made of galvanised and painted steel plate with polyester powder coating.
- The unit is also complete with:
 - fan and compressor thermal magnetic circuit breakers, heat exchanger antifreeze heater;
 - display of cooling circuit high and low pressure;
 - electronic expansion valve;
 - clock board;
 - control of Variable Primary Flow (VPF_R).

Versions

- T - High efficiency version.
- Q - Super silenced version complete with compressor technical compartment soundproofing, fans with EC motor at reduced speed.

Models

- TXAETY: EXPsystems unit.
- TXAEQY: super silenced EXPsystems unit.

Factory fitted accessories

- Tube and shell main and secondary heat exchangers.
- PUMP with single or double electric pump, one of which automatic in standby. The electric pumps are available in the main and secondary/recovery heat exchanger low or high head set-ups.
- TANK&PUMP with 700-1000 litre integrated buffer tank (depending on models) and single or double electric pump, complete with expansion tank, air vent valves, safety valve and water side pressure gauge.
- Inverter pump control for unit start-up (TXAEQY).
- Desuperheater.
- Condensing control with fans with EC motor (standard in Q versions).
- Condensing control with over-pressure fans (T version only).
- Power factor correction capacitors ($\cos\phi > 0.94$).
- Forced limit of power consumption.
- Forced noise limit.
- Energy parameter measuring device.
- Soft starter.
- Compressor box and soundproofed cooling circuit.
- Compressor soundproof enclosures.
- Cooling circuit outlet and inlet valves.
- Refrigerant leak detector.
- Cooling circuit high and low pressure gauges.
- Double safety valves.
- Coil protection nets or metal filters.
- Bottom compartment protection nets.
- Pre-painted copper/aluminium or copper/copper coils.
- Digital input for double set-point.
- 4-20 mA analogue signal for shifting set-point.
- Electrical panel antifreeze heater, buffer tank, electric pumps and desuperheater, if applicable.
- Interfaces for serial communication with other devices.
- Spring anti-vibration mounts.

Separately supplied accessories

- Remote keypad with display.
- Thermostat with display.
- Rhoss supervisors for unit monitoring and remote management.
- Rhoss sequencer for integrated management of multiple chillers.



TXAETY MODEL		4400	4440	6520	6580	6660	
COOLING OPERATIONS (AUTOMATIC 1 MODE)							
①	Nominal cooling capacity	kW	397	434,8	525,4	577,4	648,1
①	Absorbed power	kW	131,9	145	176,4	198,5	218,3
	E.E.R.		3,01	3	2,98	2,91	2,97
COOLING OPERATIONS + TOTAL RECOVERY (AUTOMATIC 2 MODE)							
③	Nominal cooling capacity	kW	400,8	441,7	531,2	583,2	654,8
③	Recovery heating capacity	kW	516,1	568,4	686,8	760,9	847,2
	T.E.R.		7,79	7,77	7,67	7,43	7,64
HEATING OPERATIONS (MODE SELECT 1-2 AUTOMATIC 3)							
②	Nominal heating capacity	kW	426,1	470,4	569,8	629,9	706,2
②	Absorbed power	kW	131,2	144,3	177	195,1	217,3
	C.O.P.		3,25	3,26	3,22	3,23	3,25
TXAEQY MODEL			4400	4440	6520	6580	6660
COOLING OPERATIONS (AUTOMATIC 1 MODE)							
①	Nominal cooling capacity	kW	379,1	408,9	497,6	540,7	609,4
①	Absorbed power	kW	136,4	150,9	182,9	213,7	224,9
	E.E.R.		2,78	2,71	2,72	2,53	2,71
COOLING OPERATIONS + TOTAL RECOVERY (AUTOMATIC 2 MODE)							
③	Nominal cooling capacity	kW	401	441,2	531,3	584	654,8
③	Recovery heating capacity	kW	516,1	568,4	686,8	760,8	847,1
	T.E.R.		7,79	7,77	7,67	7,44	7,64
HEATING OPERATIONS (MODE SELECT 1-2 AUTOMATIC 3)							
②	Nominal heating capacity	kW	420,9	462,7	569,1	622,1	696,2
②	Absorbed power	kW	126,8	138,9	170,9	186,8	208,4
	C.O.P.		3,32	3,33	3,33	3,33	3,34
TXAETY - TXAEQY MODEL			4400	4440	6520	6580	6660
④	TXAETY sound pressure	dB(A)	76	76,5	76,5	76,5	76,5
④	TXAEQY sound pressure	dB(A)	54,5	55,5	55,5	55,5	57,5
⑤	TXAETY sound power	dB(A)	96	97	97	97	98
⑤	TXAEQY sound power	dB(A)	87	88	88	88	90
	Scroll/step compressor	n.	4/4	4/4	6/6	6/6	6/6
	Circuits	n.	2	2	2	2	2
	Electrical supply	V-ph-Hz	400-3-50	400-3-50	400-3-50	400-3-50	400-3-50
DIMENSIONS AND WEIGHTS			4400	4440	6520	6580	6660
	L - Width	mm	4840	4840	5940	5940	6840
	H - Height	mm	2450	2450	2450	2450	2450
	P - Depth	mm	2260	2260	2260	2260	2260
⑥	TXAETY weight	kg	3650	3760	4480	4580	5250
⑥	TXAEQY weight	kg	4340	4360	5270	5370	6070

Data at the following conditions:

- ① Air: 35°C - Water: 12/7°C.
- ② Air: 7°C D.B. - 6°C W.B. - Water: 40/45°C.
- ③ Evaporator water: 12/7°C. Recovery output water 45°C - Nominal flow rate.
- ④ In open field (Q = 2) at 10 m from the unit.
- ⑤ Total sound power level in dB(A) based on measurements carried out in accordance with regulation UNI EN-ISO 9614.
- ⑥ Weight refers to the unit without load.

Performance according to EN 14511.

T.E.R.: Total efficiency ratio

SEASONAL ENERGY PERFORMANCE		4400	4440	6520	6580	6660	
TXAETY MODEL SEASONAL PERFORMANCE IN COOLING MODE							
①	P _{designc} (EN 14825)	kW	-	434,8	525,4	577,4	648,1
①	SEER (EN 14825)		-	4,63	4,64	4,61	4,63
②	η _{s,c}	%	-	182	183	182	182
TXAEQY MODEL SEASONAL PERFORMANCE IN COOLING MODE							
①	P _{designc} (EN 14825)	kW	-	-	497,6	540,7	609,4
①	SEER (EN 14825)		-	-	4,76	4,79	4,77
②	η _{s,c}	%	-	-	188	189	188
TXAETY MODEL SEASONAL PERFORMANCE IN HEATING MODE							
③	P _{designh} (EN 14825)	kW	361	-	-	-	-
③	SCOP (EN 14825)		3,63	-	-	-	-
④	η _s	%	142	-	-	-	-
TXAEQY MODEL SEASONAL PERFORMANCE IN HEATING MODE							
③	P _{designh} (EN 14825)	kW	358	397	-	-	-
③	SCOP (EN 14825)		3,73	3,74	-	-	-
④	η _s	%	146	147	-	-	-

- ① Low temperature application (7°C)
- ② Seasonal energy efficiency: low temperature cooling (EU Regulation 2016/2281)
- ③ In Average climatic conditions, low temperature application (35°C)
- ④ Seasonal energy efficiency: low temperature heating in Average climate (EU Regulations No.811/2013 and No.813/2013)

Comby-Flow EXP

TXHEY 105÷112

Cooling capacity: 5.5-12.2 kW - Heating capacity: 6.4-13.7 kW



- **Extremely compact multi-purpose units**

EXPsystems - Polyvalent ecological water-cooled system. Range with scroll hermetic compressors and R410A refrigerant gas.

Construction features

- Compressor: hermetic, rotary scroll type, complete with thermal protection.
- Primary side (user) and secondary side (recovery) heat exchanger and disposal unit: suitably insulated stainless steel plates, complete with antifreeze heater and water flow differential pressure switch.
- Control: microprocessor electronic control, iDRHOSS compatible with AdaptiveFunction logic.
- Condensing control: pressure switch valve and bypass solenoid valve.
- Structure: made of galvanised and painted steel plate with polyester powder coating, complete with soundproofed compressor.

Models

- TXHEY: EXPsystems unit.

PUMP set-up

- Primary side (user): pump unit complete with electric circulation pump, membrane expansion tank, safety valve, water drain valve, manual air vent valve and pressure gauge.
- Well/tower side (disposal unit): drain valve and vent valve. Internal valve for primary side system supply (user) from external network (disposal unit side: well or tower).
- Secondary side (recovery): pump unit complete with electric circulation pump, membrane expansion tank, safety valve, water fill and drain valve, manual air vent valve and pressure gauge.

Factory fitted accessories

- Digital input for double set-point
- 4-20mA analogue signal for shifting set-point.

Separately supplied accessories

- Buffer tank.
- Buffer tank connection pipes.
- Water filter.
- Rubber anti-vibration mounts.
- Antifreeze heater on the buffer tank.
- Remote keypad with display.
- Clock board.
- Interfaces for serial communication with other devices.
- Serial converter (RS485/USB).
- Rhoss supervisors for unit monitoring and remote management.

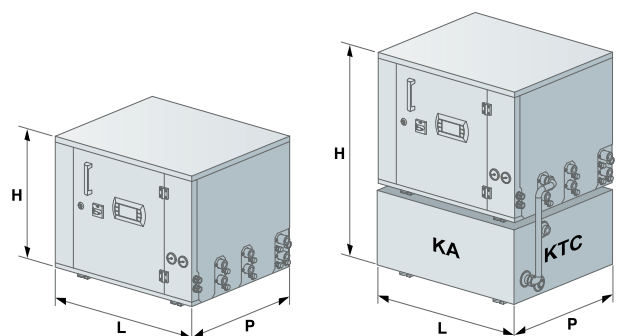



TXHEY MODEL		105	107	109	112
COOLING OPERATIONS (AUTOMATIC 1 MODE)					
① Nominal cooling capacity	kW	5,5	6,9	9,5	12,2
① Absorbed power	kW	1,74	2,27	2,99	3,82
E.E.R.		3,16	3,04	3,18	3,19
COOLING OPERATIONS + TOTAL RECOVERY (AUTOMATIC 2 MODE)					
② Nominal cooling capacity	kW	4,7	6	7,9	9,9
② Recovery heating capacity	kW	6,7	8,6	11,2	14,4
T.E.R.		5,79	5,28	5,53	5,26
HEATING OPERATIONS (MODE SELECT 1-2 AUTOMATIC 3)					
③ Nominal heating capacity	kW	6,4	8,1	10,6	13,7
④ Heating capacity	kW	7,3	9,5	12,4	14,7
③ Absorbed power	kW	2,2	3,1	3,8	4,7
C.O.P.		2,91	2,64	2,81	2,95
TXHEY MODEL					
⑤ Sound pressure	dB(A)	49	51	51	53
Scroll/step compressor	n.	1/1	1/1	1/1	1/1
Circuits	no.	1	1	1	1
KA buffer tank water content	l	20	20	30	30
① Available nominal head of pump on main heat exchanger	kPa	47	54,7	82,2	78,2
② Available nominal head on secondary recovery heat exchanger	kPa	32,4	42,4	72,1	66,7
Electrical supply	V-ph-Hz	230-1-50	230-1-50 / 400-3+N-50	230-1-50 / 400-3+N-50	230-1-50 / 400-3+N-50
DIMENSIONS AND WEIGHTS		105	107	109	112
L - Width	mm	585	585	660	660
H - TXHEY P height	mm	535	535	535	535
H - TXHEY P + KA height	mm	855	855	855	855
P - Depth	mm	520	520	560	560
TXHEY Weight	kg	112	118	122	130
KA Weight	kg	38	38	43	43

Data at the following conditions:

- ① Chilled water: 12/7°C - Condenser water: 30/35°C
 - ② Chilled water: 12/7°C - Recovery water: 40/45°C.
 - ③ Hot water: 40/45°C. Evaporator water: 10/7°C.
 - ④ Hot water: 30/35°C. Evaporator water: 10/7°C.
 - ⑤ In open field (Q = 2) at 1 m from the unit.
- Performance according to EN 14511.
 T.E.R.: Total efficiency ratio
 KA = buffer tank.
 KTC = connecting pipe.

SEASONAL ENERGY PERFORMANCE		105	107	109	112
TXHEY MODEL SEASONAL PERFORMANCE IN HEATING MODE					
③ P _{designh} (EN 14825)	kW	9	12	15	18
③ SCOP (EN 14825)		4,56	5,08	4,97	4,77
④ η _s	%	174	195	191	183
Energy class		A++	A+++	A+++	A+++

- ③ In Average climatic conditions; low temperature application (35°C)
- ④ Seasonal energy efficiency: low temperature heating in Average climate (EU Regulations No.811/2013 and No.813/2013)

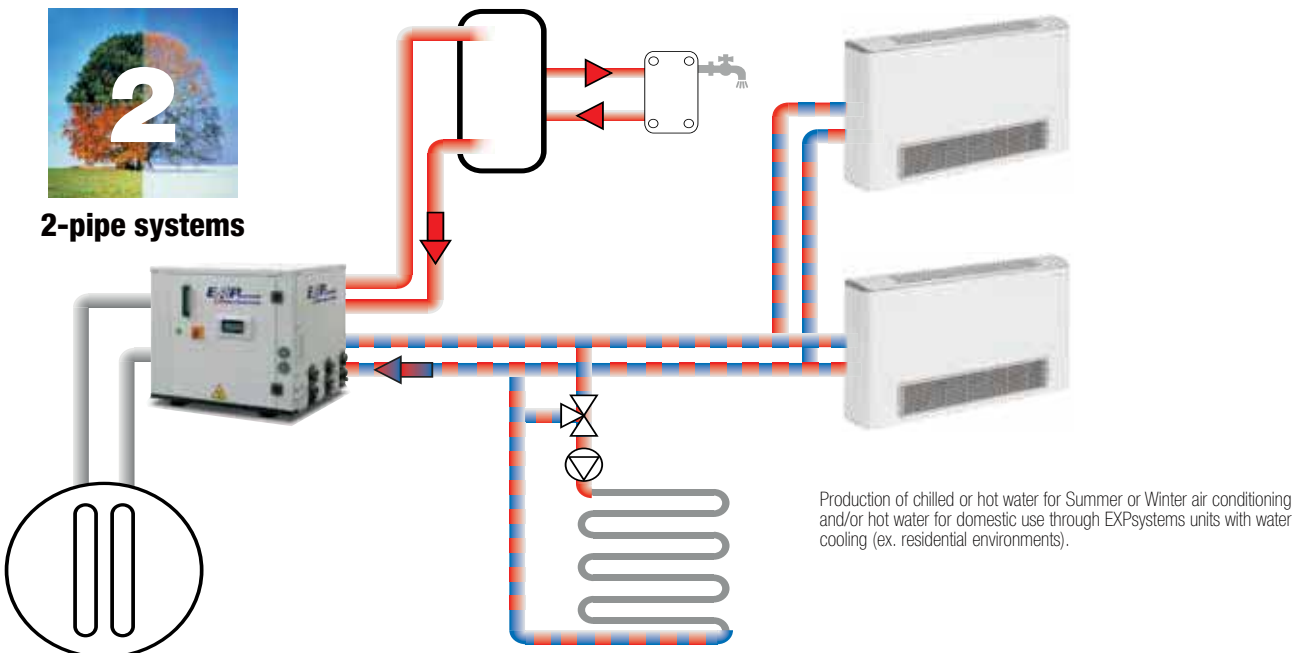

Y-Flow EXP

TXHEY 245÷4410

Cooling capacity: 44.2-397.1 kW - Heating capacity: 49.3-459.3 kW



EXPsystems - Polyvalent ecological water-cooled system. Range with scroll hermetic compressors and R410A refrigerant gas.

Construction features

- Compressor: scroll type, rotary, hermetic complete with thermal protection and casing heater.
- Primary side (user), secondary side (recovery) heat exchangers and disposal unit: crossed flow stainless steel plate exchangers, complete with antifreeze heater, closed cell polyurethane foam rubber insulation and water flow differential pressure switch.
- Control: microprocessor electronic control with Adaptive Function Plus logic.
- Structure: made of galvanised and painted steel plate with polyester powder coating.
- The unit is also complete with:
 - compressor circuit breaker switches,
 - electronic expansion valve,
 - display of cooling circuit high and low pressure,
 - clock board,
 - outdoor temperature probe for set-point compensation,
 - 0-10V analogue signal for condensing/evaporating control performed by external device;
 - control of Variable Primary Flow (VPF_R).

Versions

- B - Standard version.

Models

- TXHEY: EXPsystems unit.

Factory fitted accessories

- Cooling circuit high and low pressure gauges.
- Forced limit of power consumption.
- Soft starter.
- Silenced set up.
- Digital input for double set-point.
- 4-20 mA analogue signal for shifting set-point.
- Interfaces for serial communication with other devices.
- Anti-vibration mounts.

Separately supplied accessories

- 3-way modulating condensing control valve.
- 2-way modulating condensing control valve.
- Water filter.
- Remote keypad with display.
- Thermostat with display.
- Serial converter (RS485/USB).
- RHOSS supervisors for unit monitoring and remote management.
- Rhoss sequencer for integrated management of multiple chillers.





TXHEBY MODEL		245	250	260	270	290	2115	2130	2145	2165	2185
COOLING OPERATIONS (AUTOMATIC 1 MODE)											
① Nominal cooling capacity	kW	47	55,6	62,7	71,8	92,8	123,8	137,5	153,9	173,3	193,2
② Nominal cooling capacity	kW	44,2	52	59,2	67,6	88	114,6	128	142,4	161,7	180,6
① Absorbed power	kW	8,5	9,8	11,3	13	16,9	21,5	24,7	26,7	31,8	36,3
② Absorbed power	kW	9,9	11,4	13,1	14,9	19,1	25,5	28,8	31,7	36,8	41,9
① E.E.R.		5,51	5,69	5,55	5,51	5,48	5,75	5,57	5,76	5,44	5,32
② E.E.R.		4,49	4,57	4,52	4,54	4,61	4,5	4,45	4,5	4,4	4,32
COOLING OPERATIONS + TOTAL RECOVERY (AUTOMATIC 2 MODE)											
③ Nominal cooling capacity	kW	38,7	45,9	52,8	58,8	79,5	104,2	114,4	126,3	143	160,1
③ Recovery heating capacity	kW	50,8	59,9	68,9	76,6	103,5	135,4	149,4	165,4	188,5	212
③ Absorbed power	kW	12,2	14	16,1	17,8	24	31,6	35,4	39,5	46	52,3
③ T.E.R.		7,32	7,55	7,57	7,62	7,63	7,59	7,45	7,39	7,21	7,12
HEATING OPERATIONS (MODE SELECT 1-2 AUTOMATIC 3)											
④ Nominal heating capacity	kW	49,3	58,1	66,9	74,3	100,6	131,8	145,5	160,9	183,5	206,4
④ Total absorbed power	kW	12,1	13,9	15,9	17,6	23,7	31,4	35,14	39,1	45,6	52,1
④ C.O.P.		4,07	4,19	4,2	4,21	4,25	4,2	4,14	4,11	4,02	3,96
TXHEBY MODEL											
⑤ Sound power	dB(A)	67	67	68	68	70	72	73	74	74	75
Scroll/step compressor	n.	2/2	2/2	2/2	2/2	2/2	2/2	2/2	2/2	2/2	2/2
Circuits	n.	1	1	1	1	1	1	1	1	1	1
Electrical supply	V-ph-Hz	400-3+N-50									
DIMENSIONS AND WEIGHTS											
L - Width	mm	1020	1020	1020	1020	1020	1270	1270	1270	1270	1270
H - Height	mm	1470	1470	1470	1470	1470	1620	1620	1620	1620	1620
P - Depth	mm	870	870	870	870	870	870	870	870	870	870
⑥ Weight	kg	510	525	540	565	595	920	960	995	1035	1045

Data at the following conditions:

- ① Chilled water (user): 12/7°C - Condenser water (disposal unit-source): 14/30°C. (Gross value)
 - ② Chilled water (user): 12/7°C - Condenser water (disposal unit-source): 30/35°C
 - ③ Chilled water (user): 12/7°C - Condenser water (recovery unit): 40/45°C.
 - ④ Evaporator water (source): 10/7°C - Hot water (utility): 40/45°C.
 - ⑤ Total sound power level in dB(A) based on measurements carried out in accordance with regulation UNI EN-ISO 9614.
 - ⑥ Empty weight
- Performance according to EN 14511.
T.E.R.: Total efficiency ratio

SEASONAL ENERGY PERFORMANCE		245	250	260	270	290	2115	2130	2145	2165	2185
TXHEBY MODEL SEASONAL PERFORMANCE IN COOLING MODE											
①	P_{designc} (EN 14825)	kW	-	-	-	-	-	-	-	-	-
①	SEER (EN 14825)		-	-	-	-	-	-	-	-	-
②	$\eta_{s,c}$	%	-	-	-	-	-	-	-	-	-
TXHEBY MODEL SEASONAL PERFORMANCE IN HEATING MODE											
③	P_{designh} (EN 14825)	kW	59	69	80	89	119	156	173	191	218
③	SCOP (EN 14825)		5,95	6,14	6,27	6,16	6,05	6,47	6,36	6,35	6,13
④	η_s	%	230	238	243	238	234	251	247	246	237
Energy class		A+++	A+++	-	-	-	-	-	-	-	-

- ① Low temperature application (7°C)
- ② Seasonal energy efficiency: low temperature cooling (EU Regulation 2016/2281)
- ③ In Average climatic conditions, low temperature application (35°C)
- ④ Seasonal energy efficiency: low temperature heating in Average climate (EU Regulations No.811/2013 and No.813/2013)
- ④ Seasonal energy efficiency: low temperature heating in Average climate (EU Regulations No.811/2013 and No.813/2013)

Y-Flow EXP

TXHEY 245÷4410

TXHEBY MODEL		4180	4205	4235	4260	4290	4330	4360	4410
COOLING OPERATIONS (AUTOMATIC 1 MODE)									
① Nominal cooling capacity	kW	188,5	214,7	241,2	270,2	302,7	341,1	379,9	420,9
② Nominal cooling capacity	kW	176,4	201,7	226,7	253,6	280,2	317,9	354	397,1
① Absorbed power	kW	32,2	37,2	41,9	46,6	50,4	59,1	67,2	78,9
② Absorbed power	kW	37,4	42,9	48,2	54,1	60,2	69,3	79,1	90,5
① E.E.R.		5,85	5,77	5,76	5,8	6,01	5,77	5,65	5,33
② E.E.R.		4,72	4,71	4,71	4,69	4,66	4,59	4,48	4,39
COOLING OPERATIONS + TOTAL RECOVERY (AUTOMATIC 2 MODE)									
③ Nominal cooling capacity	kW	159,3	181	202,2	228	253,3	287	321,5	358,6
③ Recovery heating capacity	kW	203,2	232,2	260,6	293,8	327,1	372,5	418,8	469,3
③ Absorbed power	kW	44,2	51,5	58,8	66,1	73,7	85,4	96,9	110,5
③ T.E.R.		8,2	8,03	7,87	7,89	7,87	7,73	7,64	7,49
HEATING OPERATIONS (MODE SELECT 1-2 AUTOMATIC 3)									
④ Nominal heating capacity	kW	198,8	227,5	255,4	288	320	367	412,6	459,3
④ Total absorbed power	kW	43,9	51,1	58,4	65,6	72,9	84,6	95,9	109,4
④ C.O.P.		4,52	4,45	4,37	4,39	4,39	4,34	4,3	4,2
TXHEBY MODEL									
⑤ Sound power	dB(A)	77	77	78	79	80	81	82	83
Scroll/step compressor	n.	4/4	4/4	4/4	4/4	4/4	4/4	4/4	4/4
Circuits	n.	2	2	2	2	2	2	2	2
Electrical supply	V-ph-Hz	400-3-50	400-3-50	400-3-50	400-3-50	400-3-50	400-3-50	400-3-50	400-3-50
DIMENSIONS AND WEIGHTS									
L - Width	mm	2600	2600	2600	2600	2600	2600	2600	2600
H - Height	mm	1860	1860	1860	1860	1860	1860	1860	1860
P - Depth	mm	870	870	870	870	870	870	870	870
⑥ Weight	kg	1690	1730	1780	1820	1890	1960	2000	2070

Data at the following conditions:

- ① Chilled water (user): 12/7°C - Condenser water (disposal unit-source): 14/30°C. (Gross value)
- ② Chilled water (user): 12/7°C - Condenser water (disposal unit-source): 30/35°C
- ③ Chilled water (user): 12/7°C - Condenser water (recovery unit): 40/45°C.
- ④ Evaporator water (source): 10/7°C - Hot water (utility): 40/45°C.
- ⑤ Total sound power level in dB(A) based on measurements carried out in accordance with regulation UNI EN-ISO 9614.
- ⑥ Empty weight

Performance according to EN 14511.

T.E.R.: Total efficiency ratio

SEASONAL ENERGY PERFORMANCE		4180	4205	4235	4260	4290	4330	4360	4410
TXHEBY MODEL SEASONAL PERFORMANCE IN COOLING MODE									
①	P_{designc} (EN 14825)	kW	-	-	-	-	317,9	354	397,1
①	SEER (EN 14825)		-	-	-	-	6,24	6,14	5,94
②	$\eta_{s,c}$	%	-	-	-	-	247	242	234
TXHEBY MODEL SEASONAL PERFORMANCE IN HEATING MODE									
③	P_{designh} (EN 14825)	kW	234	267	300	340	379	-	-
③	SCOP (EN 14825)		6,75	6,65	6,54	6,6	6,68	-	-
④	η_s	%	262	258	253	256	259	-	-
	Energy class		-	-	-	-	-	-	-

- ① Low temperature application (7°C)
- ② Seasonal energy efficiency: low temperature cooling (EU Regulation 2016/2281)
- ③ In Average climatic conditions, low temperature application (35°C)
- ④ Seasonal energy efficiency: low temperature heating in Average climate (EU Regulations No.811/2013 and No.813/2013)
- ④ Seasonal energy efficiency: low temperature heating in Average climate (EU Regulations No.811/2013 and No.813/2013)





CONDENSING UNITS

Condensing units

MCAEBY 115÷130

Cooling capacity: 16.4-31.5 kW



**Air cooled condensing units with axial fans.
Range with hermetic compressors and R410A
refrigerant gas.**

Construction features

- Compressor: Scroll hermetic complete with thermal protection and crankcase heater.
- Air side heat exchanger: featuring finned coil with copper pipes and aluminium fins, complete with protective mesh.
- Fan: external rotor axial type electric fans equipped with internal thermal protection, accident protection grilles and proportional electronic device for pressure and continuous fan rotation speed adjustment.
- Control: microprocessor electronic control.
- Structure: made of galvanised and painted steel plate

Models

- MCAEBY: unit designed for cooling only.

Factory fitted accessories

- Silenced set up.

Separately supplied accessories

- Rubber anti-vibration mounts.
- RS485 Interface for serial communication with other devices.
- Serial converter (RS485/USB).

MCAEBY MODEL		115	117	122	124	127	130
❶ Nominal cooling capacity	kW	16,4	18,5	24,7	26,5	29	31,5
❶ Absorbed power	kW	5,5	6,3	7,9	9	9,8	11
MCAEBY MODEL		115	117	122	124	127	130
❸ Sound pressure	dB(A)	50	50	52	52	53	53
Electrical supply	V-ph-Hz	400-3+N-50	400-3+N-50	400-3+N-50	400-3+N-50	400-3+N-50	400-3+N-50
DIMENSIONS AND WEIGHTS		115	117	122	124	127	130
L - Width	mm	1230	1230	1230	1230	1535	1535
H - Height	mm	1090	1090	1280	1280	1510	1510
P - Depth	mm	580	580	600	600	695	695
MCAEBY Weight	kg	140	150	200	225	270	300

Data at the following conditions:

- ❶ Air: 35°C - Saturated intake gas: 5°C.
- ❸ In open field (Q = 2) at 5 m from the unit.

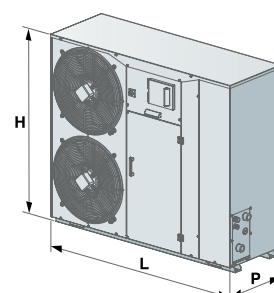

Condensing units

MCAEBY 233÷2160



Cooling capacity: 34.5-162.6 kW



Air cooled condensing units with axial fans.
Range with scroll hermetic compressors and R410A refrigerant gas.

Construction features

- Compressor: hermetic, rotary scroll type, complete with thermal protection and crankcase heater.
- Air side heat exchanger: finned coil with copper pipes and aluminium fins.
- Fan: external rotor axial type electric fans equipped with internal thermal protection, accident protection grilles and proportional electronic device for continuous fan rotation speed adjustment.
- Control: microprocessor electronic control.
- Structure: in hot galvanised and painted sheet steel, with polyurethane powder coating.

- The unit is also complete with:
 - compressor and fan circuit breaker switches,
 - pre-loaded with R410A gas.

Models

- MCAEBY: unit designed for cooling only.

Factory fitted accessories

- Silenced version
 - Coil protection metal filters.
- Cooling circuit high and low pressure gauges.
- Liquid receiver.
- Pre-painted copper/aluminium or copper/copper coils.
- Rubber anti-vibration mounts.

Separately supplied accessories

- Thermostatic valve kit.
- Interfaces for serial communication with other devices.
- Serial converter (RS485/USB).

MCAEBY MODEL		233	238	245	250	260	265
❶ Nominal cooling capacity	kW	34,5	41,2	46,7	54,3	62,5	67,7
❶ Absorbed power	kW	12,5	14,7	17,6	19,9	22,4	24,3
MCAEBY MODEL		233	238	245	250	260	265
❸ Sound pressure	dB(A)	46,5	47	48	48	49	49
Electrical supply	V-ph-Hz	400-3+N-50	400-3+N-50	400-3+N-50	400-3+N-50	400-3+N-50	400-3+N-50
DIMENSIONS AND WEIGHTS		233	238	245	250	260	265
L - Width	mm	1710	2315	2315	2315	2315	2315
H - Height	mm	1570	1570	1570	1570	1570	1570
P - Depth	mm	1000	1000	1000	1000	1000	1000
MCAEBY Weight	kg	400	546	536	570	586	624

MCAEBY MODEL		280	290	2100	2115	2130	2145	2160
❶ Nominal cooling capacity	kW	79,1	87,1	101	116,2	126,5	145,6	162,6
❶ Absorbed power	kW	28,4	32,9	36,2	41,2	46,2	52,9	60,2
MCAEBY MODEL		280	290	2100	2115	2130	2145	2160
❸ Sound pressure	dB(A)	50	52	52	58	58	58	59
Electrical supply	V-ph-Hz	400-3+N-50	400-3+N-50	400-3+N-50	400-3+N-50	400-3+N-50	400-3+N-50	400-3+N-50
DIMENSIONS AND WEIGHTS		280	290	2100	2115	2130	2145	2160
L - Width	mm	2650	3150	3150	3150	3150	3150	3450
H - Height	mm	1700	1700	1700	1730	1730	1730	1700
P - Depth	mm	1210	1210	1210	1210	1210	1210	1210
MCAEBY Weight	kg	880	935	950	998	998	1052	1108

Data at the following conditions:

- ❶ Air: 35°C - Saturated intake gas: 5°C.
- ❸ In open field (Q = 2) at 10 m from the unit.

A modern, multi-story building with a facade of glass and metal panels is shown against a blue sky with white clouds. A large, semi-transparent blue circle is overlaid on the center of the image. Inside the circle, the text "SYSTEM ACCESSORIES" is written in white, bold, uppercase letters. A horizontal line of white dots passes through the center of the circle, extending across the width of the image.

SYSTEM ACCESSORIES

Remote condensers

CCAMY 115÷2185



Installazione verticale (V)

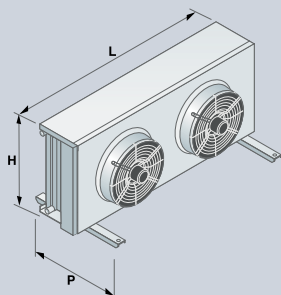

Installazione orizzontale (H)

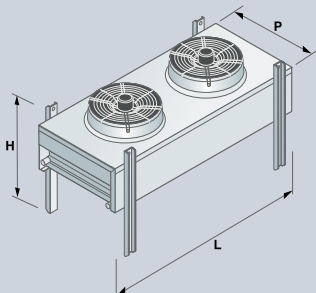

Installazione verticale (V)

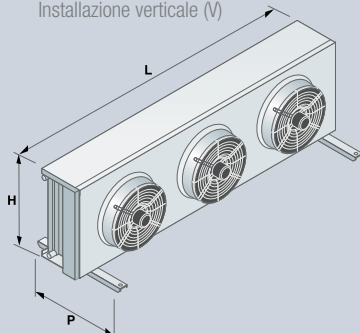

Installazione orizzontale (H)

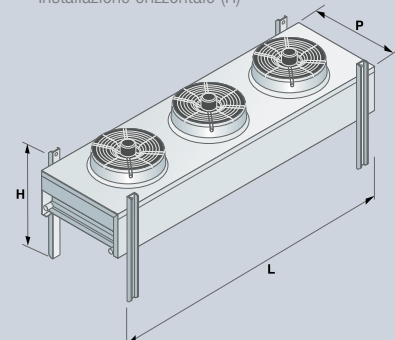

Remote air condensers with axial fans for direct expansion units operating with R410A refrigerant gas.

Construction features

- Heat exchanger: with high efficiency finned coil with copper pipes mechanically expanded on aluminium fins. The cooling unit connection fittings require brazing. Design pressure 40 barg. Each heat exchanger is tested against leaks with dry air and supplied preloaded with nitrogen.
- Fans: of axial type with external rotor with fans equipped with innovative polymer blades and integrated thermal protection to provide protection against thermal overload. IP54 protection rating, in compliance with DIN 40050. The fan motors are also standard supplied with phase cutting speed control.
- Structure: pre-painted galvanised steel plate with epoxy finish (RAL 9002). The coil structure is made of Aluminium alloy (AlMg3), for protection against vibration and thermal expansion. The condensers are supplied with support bracket kit for vertical installation with horizontal air flow (CCAMY V) or horizontal with vertical air flow (CCAMY H).

The support brackets are made of galvanised steel. Electrical panel complete with:

- electrical wiring suited for 400V-3ph-50Hz power supply voltage;
- electrical supply junction box with disconnecting switch where the general power supply voltage of the remote condenser can be connected;
- self-extinguishing plastic casing (IP55) containing the fan rotation speed continuous control device, via a phase cut device,
- pressure probe,
- fan electrical wiring,
- contact for external signal of fan thermal intervention, remote on/off contact.

Versions

- The CCAMY series remote condensers are available in 3 construction options that meet the different system requirements regarding ambient noise emission containment:
 - Basic "B" version (except mod.115 and 118)
 - Version "S" Silenced
 - Version "Q" Super-silenced



CCAMBY MODEL		122	125	230	240		
VERSION B "Basic"							
① Nominal heating capacity	kW	27	30	41	51		
② Sound pressure	dB(A)	46	49	51	51		
Cooling circuits	n.	1	1	1	1		
Fans	no.	1	1	1	2		
Fan nominal air flow	m³/h	6036	6986	11000	12780		
Rotation speed	rpm	1110	1360	1330	1110		
① Absorbed power	kW	0,49	0,69	1,25	0,98		
Electrical supply	V-ph-Hz	400-3-50	400-3-50	400-3-50	400-3-50		
DIMENSIONS AND WEIGHT							
H horizontal installation							
L - Width	mm	1115	1115	1261	2015		
H - Height	mm	846	846	1171	846		
P - Depth	mm	868	868	1100	868		
V vertical installation							
L - Width	mm	1115	1115	1261	2015		
H - Height	mm	828	828	1034	828		
P - Depth	mm	470	470	750	470		
Weight *	Kg	54	54	83	92		
CCAMSY MODEL							
		115	118	122	125	230	240
VERSION S "Silenced"							
① Nominal heating capacity	kW	19,5	22	28,5	31	39,5	47
② Sound pressure	dB(A)	37	39	32	40	42	43
Cooling circuits	n.	1	1	1	1	1	1
Fans	no.	1	1	2	2	2	2
Fan nominal air flow	m³/h	4629	4394	7527	8536	9258	14510
Rotation speed	rpm	920	920	680	785	920	690
① Absorbed power	kW	0,26	0,26	0,3	0,38	0,52	0,8
Electrical supply	V-ph-Hz	400-3-50	400-3-50	400-3-50	400-3-50	400-3-50	400-3-50
DIMENSIONS AND WEIGHT							
H horizontal installation							
L - Width	mm	1115	1115	2015	2015	2015	2261
H - Height	mm	846	846	846	846	846	1171
P - Depth	mm	868	868	868	868	868	1100
V vertical installation							
L - Width	mm	1115	1115	2015	2015	2015	2261
H - Height	mm	828	828	828	828	828	1034
P - Depth	mm	470	470	470	470	470	750
Weight *	Kg	49	54	83	92	92	121
CCAMQY MODEL							
		115	118	122	125	230	240
VERSION Q "Super-silenced"							
① Nominal heating capacity	kW	19	21,5	26	32	36,5	49
② Sound pressure	dB(A)	36	31	31	32	40	34
Cooling circuits	n.	1	1	1	1	1	1
Fans	no.	1	1	1	2	2	2
Fan nominal air flow	m³/h	3779	5537	4993	7060	8016	10500
Rotation speed	rpm	785	650	650	680	785	650
① Absorbed power	kW	0,19	0,24	0,24	0,3	0,38	0,47
Electrical supply	V-ph-Hz	400-3-50	400-3-50	400-3-50	400-3-50	400-3-50	400-3-50
DIMENSIONS AND WEIGHT							
H horizontal installation							
L - Width	mm	1115	1261	1261	2015	2015	2261
H - Height	mm	846	1171	1171	846	846	1171
P - Depth	mm	868	1100	1100	868	868	1100
V vertical installation							
L - Width	mm	1115	1261	1261	2015	2015	2261
H - Height	mm	828	1034	1034	828	828	1034
P - Depth	mm	470	750	750	470	470	750
Weight *	Kg	54	78	85	94	101	135

Data at the following conditions:

- ① Outdoor air temperature 35°C D.B., condensation temperature 50°C, desuperheating 25°K. Maximum speed
- ② In open field (Q = 2) at 10 m from the unit.
- * Empty weight

Sound pressure level correction for distances other than 10m

Distance	(m)	2	3	4	5	7	10	15	20
Correction	dB(A)	11	8,5	7	5	2,5	0	-3	-5,5

Remote condensers

CCAMY 115÷2185

CCAMBY MODEL		245	250	260	270	275	290
VERSION B "Basic"							
① Nominal heating capacity	kW	57	68	79	80	89,5	109
② Sound pressure	dB(A)	52	54	54	54	54	56
Cooling circuits	n.	1	1	1	1	1	1
Fans	no.	2	3	2	2	2	4
Fan nominal air flow	m³/h	9258	23280	22000	22000	21070	29400
Rotation speed	rpm	920	1360	1330	1330	1330	1360
① Absorbed power	kW	0,52	2,07	2,5	2,5	2,5	2,76
Electrical supply	V-ph-Hz	400-3-50	400-3-50	400-3-50	400-3-50	400-3-50	400-3-50
DIMENSIONS AND WEIGHT							
H horizontal installation							
L - Width	mm	2015	2915	2261	2261	2261	3815
H - Height	mm	846	846	1171	1171	1171	846
P - Depth	mm	868	868	1100	1100	1100	868
V vertical installation							
L - Width	mm	2015	2915	2261	2261	2261	3261
H - Height	mm	828	828	1034	1034	1034	828
P - Depth	mm	470	470	750	750	750	470
Weight *	Kg	101	136	169	169	169	237
CCAMSY MODEL							
VERSION S "Silenced"							
① Nominal heating capacity	kW	54	69	77	85	99,5	106,5
② Sound pressure	dB(A)	48	48	49	50	50	51
Cooling circuits	n.	1	1	1	1	1	1
Fans	no.	2	2	2	3	3	3
Fan nominal air flow	m³/h	18020	16920	17030	27030	25380	27070
Rotation speed	rpm	890	890	1070	890	890	1070
① Absorbed power	kW	1,2	1,2	1,68	1,8	1,8	2,52
Electrical supply	V-ph-Hz	400-3-50	400-3-50	400-3-50	400-3-50	400-3-50	400-3-50
DIMENSIONS AND WEIGHT							
H horizontal installation							
L - Width	mm	2261	2261	2261	3261	3261	3261
H - Height	mm	1171	1171	1171	1171	1171	1171
P - Depth	mm	1100	1100	1100	1100	1100	1100
V vertical installation							
L - Width	mm	2261	2261	2261	3261	3261	3261
H - Height	mm	1034	1034	1034	1034	1034	1034
P - Depth	mm	750	750	750	750	750	750
Weight *	Kg	121	136	149	193	237	257
CCAMQY MODEL							
VERSION Q "Super-silenced"							
① Nominal heating capacity	kW	55	64	74,5	84	92	113
② Sound pressure	dB(A)	35	44	45	45	44	45
Cooling circuits	n.	1	1	1	1	1	1
Fans	no.	4	3	3	3	3	4
Fan nominal air flow	m³/h	15050	13180	21760	20060	18660	26740
Rotation speed	rpm	680	920	690	690	690	690
① Absorbed power	kW	0,6	0,78	1,2	1,2	1,2	1,6
Electrical supply	V-ph-Hz	400-3-50	400-3-50	400-3-50	400-3-50	400-3-50	400-3-50
DIMENSIONS AND WEIGHT							
H horizontal installation							
L - Width	mm	3815	2915	3261	3261	3261	4261
H - Height	mm	846	846	1171	1171	1171	1171
P - Depth	mm	868	868	1100	1100	1100	1100
V vertical installation							
L - Width	mm	3815	2915	3261	3261	3261	4261
H - Height	mm	828	828	1034	1034	1034	1034
P - Depth	mm	470	470	750	750	750	750
Weight *	Kg	140	149	192	210	216	274

Data at the following conditions:

① Outdoor air temperature 35°C D.B., condensation temperature 50°C, desuperheating 25°K. Maximum speed

② In open field (Q = 2) at 10 m from the unit.

* Empty weight

CCAMBY MODEL		2100	2115	2130	2145	2165	2185	
VERSION B "Basic"								
①	Nominal heating capacity	kW	123,5	135	159	174,5	201	222
②	Sound pressure	dB(A)	56	56	57	57	58	58
	Cooling circuits	n.	1	1	1	1	1	1
	Fans	no.	3	3	4	4	5	5
	Fan nominal air flow	m³/h	33000	31600	44090	42140	54990	52670
	Rotation speed	rpm	1330	1330	1330	1330	1330	1330
①	Absorbed power	kW	3,75	3,75	5	5	6,25	6,25
	Electrical supply	V-ph-Hz	400-3-50	400-3-50	400-3-50	400-3-50	400-3-50	400-3-50

DIMENSIONS AND WEIGHT								
H horizontal installation								
	L - Width	mm	3261	3261	4261	4261	5261	5261
	H - Height	mm	1171	1171	1171	1171	1171	1171
	P - Depth	mm	1100	1100	1100	1100	1100	1100
V vertical installation								
	L - Width	mm	3261	3261	4261	4261	5261	5261
	H - Height	mm	1034	1034	1034	1034	1034	1034
	P - Depth	mm	750	750	750	750	750	750
	Weight *	Kg	257	257	310	327	421	451

CCAMSY MODEL		2100	2115	2130	2145	2165	2185	
VERSION S "Silenced"								
	Nominal heating capacity	kW	130,5	135	160	172,5	191	223,5
②	Sound pressure	dB(A)	51	51	52	53	53	53
	Cooling circuits	n.	1	1	1	1	1	1
	Fans	no.	4	4	4	5	5	6
	Fan nominal air flow	m³/h	33840	33840	34070	45120	42590	51100
	Rotation speed	rpm	890	890	1070	1070	1070	1070
①	Absorbed power	kW	2,4	2,4	3,36	4,2	4,2	5,04
	Electrical supply	V-ph-Hz	400-3-50	400-3-50	400-3-50	400-3-50	400-3-50	400-3-50

DIMENSIONS AND WEIGHT								
H horizontal installation								
	L - Width	mm	4261	4261	4261	5261	5261	6261
	H - Height	mm	1171	1171	1171	1171	1171	1171
	P - Depth	mm	1100	1100	1100	1100	1100	1100
V vertical installation								
	L - Width	mm	4261	4261	4261	5261	5261	6261
	H - Height	mm	1034	1034	1034	1034	1034	1034
	P - Depth	mm	750	750	750	750	750	750
	Weight *	Kg	302	327	335	421	451	488

CCAMQY MODEL		2100	2115	2130	2145	2165	2185	
VERSION Q "Super-silenced"								
①	Nominal heating capacity	kW	125	139	157	181	203	212,5
②	Sound pressure	dB(A)	45	45	46	50	50	50
	Cooling circuits	n.	1	1	1	1	1	1
	Fans	no.	4	5	5	5	6	6
	Fan nominal air flow	m³/h	24880	33430	31100	39920	50760	47900
	Rotation speed	rpm	690	690	690	890	890	890
①	Absorbed power	kW	1,6	2	2	3	3,6	3,6
	Electrical supply	V-ph-Hz	400-3-50	400-3-50	400-3-50	400-3-50	400-3-50	400-3-50

DIMENSIONS AND WEIGHT								
H horizontal installation								
	L - Width	mm	4261	5261	5261	5261	6261	6261
	H - Height	mm	1171	1171	1171	1171	1171	1171
	P - Depth	mm	1100	1100	1100	1100	1100	1100
V vertical installation								
	L - Width	mm	4261	5261	5261	5261	6261	6261
	H - Height	mm	1034	1034	1034	1034	1034	1034
	P - Depth	mm	750	750	750	750	750	750
	Weight *	Kg	274	383	383	421	443	450

Data at the following conditions:

- ① Outdoor air temperature 35°C D.B., condensation temperature 50°C, desuperheating 25°K. Maximum speed
- ② In open field (Q = 2) at 10 m from the unit.
- * Empty weight

Pumping units

AS 0300÷2500



- 300 to 2,500 L buffer tank.
- Multiple combinations user side electric pumps
- Connection to system on delivery or on return

Pumping units with buffer tank.

Construction features

- Buffer tank: in carbon steel with a capacity of 300, 500, 750, 1,000, 1,500, or 2,500 litres.
- Hydraulic components: single or double centrifugal type electric pump, inlet and delivery ball shut-off valve of each electric pump, automatic replenishment cock, manual replenishment cock, safety valve, automatic air vent valve, tank water drain cock, membrane expansion tank, non-return valve (with double pump only), pressure gauge.
- The water circuit is insulated with closed cell expanded polyurethane of adequate thickness.
- Structure: galvanised and painted steel plate supporting structure.
- Control: electromechanical

Versions

- AS - Standard version with two connections.

Models

- AS 0300 UP or DUP 1-5: pump unit equipped with single user pump (UP) or double user pump (DUP).
- AS 0500 UP or DUP 1-5: pump unit equipped with single user pump (UP) or double user pump (DUP).
- AS 0750 UP or DUP 6-10: pump unit equipped with single user pump (UP) or double user pump (DUP).
- AS 1000 UP or DUP 6-10: pump unit equipped with single user pump (UP) or double user pump (DUP).
- AS 1500 UP or DUP 6-14: pump unit equipped with single user pump (UP) or double user pump (DUP).
- AS 2500 UP or DUP 6-14: pump unit equipped with single user pump (UP) or double user pump (DUP).

Factory fitted accessories

- Tank antifreeze electrical resistance complete with activator.

Separately supplied accessories

- Victaulic fittings.

MODEL		AS 0300	AS 0500	AS 0750	AS 1000	AS 1500	AS 2500
Tank capacity	l	300	500	750	1000	1500	2500
Electric pump model		1-2-3-4-5	1-2-3-4-5	6-7-8-9-10	6-7-8-9-10	6-7-8-9-10-11-12-13-14	6-7-8-9-10-11-12-13-14
Expansion tank capacity	l	25	25	25	25	3X25	3X25
Expansion tank pre-load	bar	1,5	1,5	1,5	1,5	1,5	1,5
Safety valve calibration	bar	3	3	3	3	3	3
Maximum operating pressure	bar	3	3	3	3	3	3
Electrical resistance (optional)	W	1300	1300	1300	1300	1.300X2	1.300X2
Hydraulic connections (female)	Ø (Gas)	21/2"	21/2"	3"	3"	4"	4"
Minimum liquid temperature	°C	-10	-10	-10	-10	-10	-10
Electrical supply	V-pH-Hz	400-3-50	400-3-50	400-3-50	400-3-50	400-3-50	400-3-50
DIMENSIONS AND WEIGHTS		AS 0300	AS 0500	AS 0750	AS 1000	AS 1500	AS 2500
L - Width	mm	1504	1504	2044	2044	2260	2260
H - Height	mm	1265	1265	1510	1510	1782	1782
P - Depth	mm	1120	1120	1200	1200	1900	1900
Weight (*)	kg	194	215	377	400	660	712
Weight (**)	kg	231	253	501	528	878	930

(*) Empty weight with 1 pump
 (**) Empty weight with 2 pumps

TANK	PUMP	Electrical supply	Maximum absorbed power	Portata	Prevalenza utile	Portata	Prevalenza utile	Portata	Prevalenza utile
Capacity (l)	Model	V-pH-Hz	kW	m³/h	m.c.a.	m³/h	m.c.a.	m³/h	m.c.a.
300 or 500	1	400-3-50	1.1	12	15,5	15	13,5	18	11,1
300 or 500	2	400-3-50	1.5	12	19	15	17	18	14,7
300 or 500	3	400-3-50	1.5	21	12,4	24	10,8	30	7,5
300 or 500	4	400-3-50	2.2	21	18,2	24	16,6	30	13,3
300 or 500	5	400-3-50	3	21	20,4	24	18,8	30	15,6
750 or 1,000	6	400-3-50	3	36	18,5	42	16,5	48	14
750 or 1,000	7	400-3-50	5.5	42	27	48	25	60	20
750 or 1,000	8	400-3-50	5.5	60	20	72	17	84	12,5
750 or 1,000	9	400-3-50	7.5	72	22	84	18,5	96	14,5
750 or 1,000	10	400-3-50	11	72	31	84	27,5	96	24
1,500 or 2,500	11	400-3-50	15	72	38,5	84	35	96	31
1,500 or 2,500	12	400-3-50	15	108	29	120	27	138	24,5
1,500 or 2,500	13	400-3-50	18.5	108	34	120	32	138	29,5
1,500 or 2,500	14	400-3-50	22	108	40	120	38,5	138	36

Diagram with AS pump unit on delivery

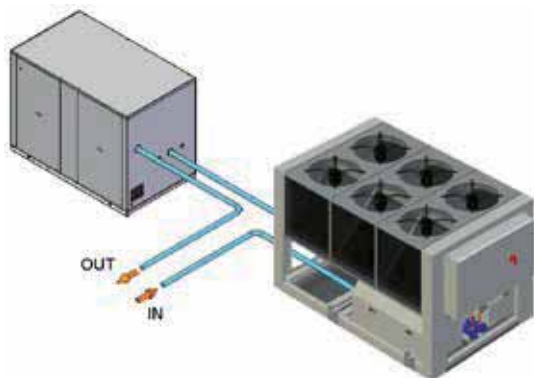
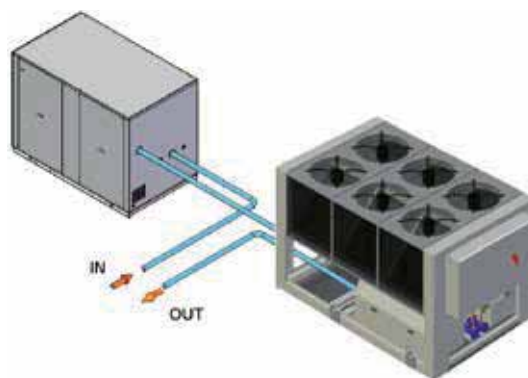

Diagram with AS pump unit on return



Boilers for domestic hot water

KACS

Capacity: 200-300-500 L

Can be combined with Electa-ECO and Electa-ECOS-B, the KACS buffer tank, for domestic hot water production from heat pump, easily completes your system.

- Large exchange surface for heat pump operation
- Absolute hygiene
- Easy installation



Buffer tanks for the production of domestic hot water from a heat pump.

Construction features

Boiler with a carbon steel coil, complete with anodic protection, internal treatment of food-grade inorganic glass-porcelain according to DIN 4753-3 and UNI 10025 standards. External insulation in injected rigid polyurethane, 50 mm thick.

Single phase copper immersion electrical resistance (IP 65) with internal adjustable thermostat and temperature limiter.

Versions

- KACSB - Boiler with coil for the production of domestic hot water from the heat pump and supplementary electrical resistance
- KACSS - Two-coil boiler for domestic hot water production from the heat pump and solar panels, with supplementary electrical resistance.

KACS boilers are to be provided together with the Electa-ECO and Electa-ECOS-B heat pumps, as shown in the table

Electa ECO	KACSB 200	KACSB 300	KACSB 500	KACSS 300	KACSS 500
106	✓	✓	✓	✓	✓
108	✓	✓	✓	✓	✓
110		✓	✓	✓	✓
114			✓		✓
116			✓		✓

Electa ECOS-B	KACSB 200	KACSB 300	KACSB 500	KACSS 300	KACSS 500
104	✓	✓		✓	
106	✓	✓	✓	✓	✓
108	✓	✓	✓	✓	✓
110		✓	✓	✓	✓

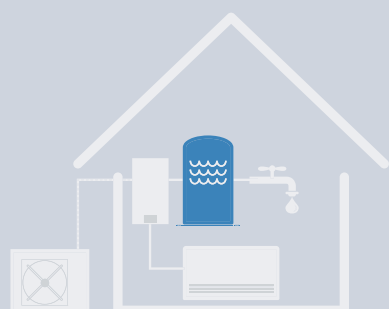
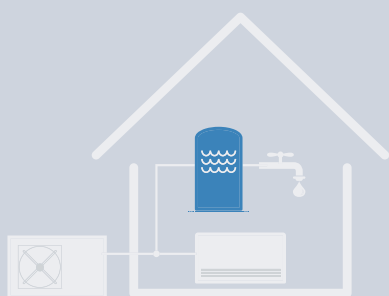



KACSB

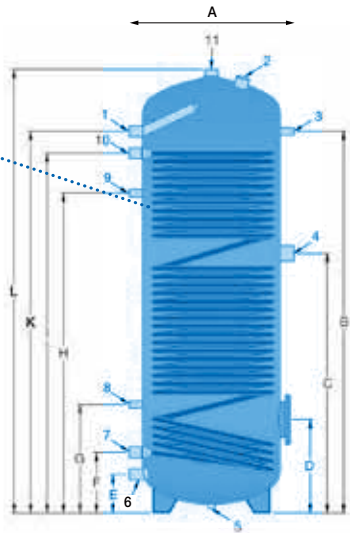

KACSS

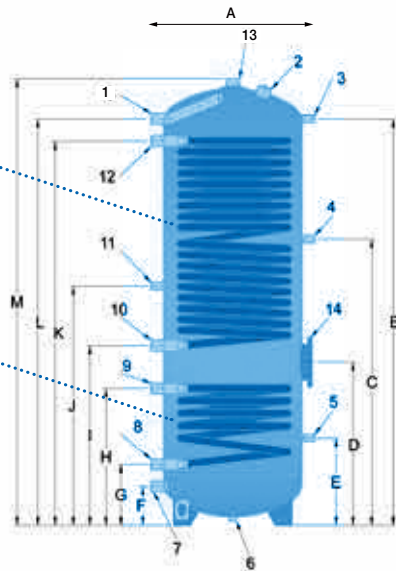

Model	A	B	C	D	E	F	G	H	I	K	L
200	600	995	735	320	140	220	370	835	990	1070	1215
300	600	1390	945	340	140	220	395	1165	1310	1390	1615
500	750	1425	970	370	185	265	425	1170	1325	1415	1705

Model	A	B	C	D	E	F	G	H	I	J	K	L	M
300	600	1470	1035	590	315	140	220	495	650	865	1390	1470	1615
500	750	1500	1045	625	320	185	275	525	700	950	1395	1500	1705

No.	TYPE OF CONNECTION	MODEL	
		200 - 300	500
1.	Hot water delivery	1"	1"
2.	Anode	1" 1/4	1" 1/4
3.	Thermometer	1/2"	1/2"
4.	Electrical resistance	1" 1/2	1" 1/2
5.	Blind fastening connection	1/2"	1/2"
6.	Cold water inlet	1"	1"
7.	Coil return	1"	1" 1/4
8.	Probe	1/2"	1/2"
9.	Recirculation	1/2"	1/2"
10.	Coil delivery	1"	1" 1/4
11.	Hot water delivery	1" 1/4	1" 1/4

No.	TYPE OF CONNECTION	MODEL	
		300 - 500	
1.	Hot water delivery	1" 1/4	
2.	Anode	1" 1/4	
3.	Thermometer	1/2"	
4.	Thermostat	1/2"	
5.	Thermostat	1/2"	
6.	Blind fastening connection	1/2"	
7.	Cold water inlet	1"	
8.	Lower coil return	1"	
9.	Lower coil delivery	1"	
10.	Upper coil return	1"	
11.	Recirculation	1/2"	
12.	Upper coil delivery	1"	
13.	Hot water delivery	1"	
14.	Flange with electrical resistance connection	1" 1/2	

MODEL		KACSB - 200	KACSB - 300	KACSB - 500	KACSS - 300	KACSS - 500
Available volume	l	190	263	470	260	455
Coil surface	m ²	3	4	6	3,7	5,2
Lower coil surface	m ²	-	-	-	1,2	1,8
Coil water content	l	17,2	23	51,5	18	31
Lower coil water content	l	-	-	-	8	10
Maximum pressure on the DHW/coil side	bar	10/10	10/10	10/10	10/10	10/10
Electrical resistance	kW	2	3	3	3	3

DIMENSIONS AND WEIGHTS		KACSB - 200	KACSB - 300	KACSB - 500	KACSS - 300	KACSS - 500
Diameter	mm	600	600	750	600	750
Total height	mm	1215	1615	1705	1615	1705
Empty weight	kg	90	124	160	131	182

ENERGY CLASS		KACSB - 200	KACSB - 300	KACSB - 500	KACSS - 300	KACSS - 500
Losses through dispersion	W	67	85	112	85	112
Energy class		C	C	C	C	C

Regulations (EU) No.812/2013 and No.814/2013.

Thermal flywheel

KSI

Capacity: 25-50-100-200 L

- Long life without corrosion
- Easy installation



Buffer tanks

Construction features

KSI – Technical water tank
Tank for heating and cooling water as a thermal flywheel or hydraulic separator, in raw steel painted externally with external insulation in injected rigid polyurethane, 50 mm thick.

MODEL		KSI - 25	KSI - 50	KSI - 100	KSI - 200
Available volume	l	24	58	126	203
Maximum operating pressure	bar	6	6	6	6

DIMENSIONS AND WEIGHTS		KSI - 25	KSI - 50	KSI - 100	KSI - 200
Diameter	mm	380	400	500	550
Total height	mm	455	935	1095	1395
Empty weight	kg	18	25	35	45

ENERGY CLASS		KSI - 25	KSI - 50	KSI - 100	KSI - 200
Losses through dispersion	W	19	34	50	68
Energy class		A	B	B	C

Regulations (EU) No.812/2013 and No.814/2013.

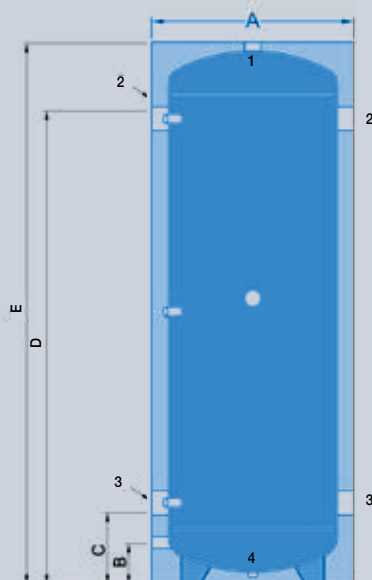

Model	A	B	C	D	E
25	380	80	165	300	455
50	400	100	180	785	935
100	500	100	185	935	1095
200	550	105	215	1200	1395

No.	TYPE OF CONNECTION	MODEL 50-100
1.	Vent	1"
2.	Delivery	1" 1/4
3.	Return	1" 1/4
4.	Drain	1/2"



FAN COILS

Slim

With its slim and exclusive design and simple and essential shape, BRIO-I Slim furnishes the environment with a touch of discreet elegance.



BRIO-I Slim



BRIO-I Slim is simple and memorable for its design, silence, comfort, low consumption and user experience.

A product designed from the future.

Multi-form

Flexible versions with a cabinet and recessed, wall-supported formwork or false ceiling installation, BRIO-I Slim **structures any architectural requirement.**

Unparalleled silence

Barely audible when operating at low speed and efficient when required, **with continuous modulation** at skilfully controlled speed, BRIO-I Slim **can provide the right day and night comfort without ever being heard.**



Low consumption

The EC electronic motor compresses consumption to extremely low values and enables **constant performance control** with advanced logic **based on actual room requirements, without any waste.**



With touch control

The **intuitive touch control** makes the control unit extremely easy to use: the wall-mounted control panel responds immediately to the commands **with a simple touch.**



Radiant heating

The radiant function creates a **pleasant sense of well-being** through heat distributed from the front panel, which heats **during winter operation.**



Fan coils with EC motor

BRIO-I SLIM

Cooling capacity: 1.0-4.0 kW - Heating capacity: 1.4-5.5 kW

INVERTER

- Exclusive design with thin profile
- Silent operation
- Excellent room comfort with continuous regulation of the fan speed
- Low consumption with standard EC motor
- Versions with cabinet and recessed with front radiant function
- Touch control

Floor and ceiling fan coil units with cabinet for recessed wall or false ceiling installation.

Construction features

- Heat exchanger: finned coil with Eurokonus ¾" connections on the left; connections on the right with accessory supplied separately.
- Tangential fan with constant speed adjustment EC electronic motor and low-consumption micro-fans in the version with radiant function.
- Cabinet version structure: covering cabinet consisting of a painted sheet metal central panel and sides made of ABS polymer (or painted sheet metal for 4T units - 4-pipe systems), RAL9003 colour with matt finish, upper delivery grille in silver grey painted aluminium. Complete unit with vertical condensate drain pan and an additional one with a natural drain, a regenerable filter and fixing brackets.
- Recessed version structure: in galvanised sheet steel, complete with a vertical condensate drain pan and an additional horizontal one with a natural drain, a regenerable filter and fixing brackets.

Versions

- MVP - Vertical unit with cabinet for wall mounting installation or with feet on the ground; ceiling installation with accessory supplied separately (KVXO)
- IXP - Recessed horizontal/vertical unit for wall or false ceiling installation.
- MVR - Vertical only unit with cabinet and front radiant function, for wall mounting installation or with feet on the ground (only unit 2T).
- IVR - Vertical only recessed unit with front radiant function, for wall formwork installation (only unit 2T).

Construction set-ups

Type of unit

- 2T - Single main coil.
- 4T - Double main coil and additional (MVP and IXP versions only).

ACCESSORIES

- Cable for water connections on the right side.
- Eurokonus / Gas connection straight fitting.
- ❖ 2-way ON/OFF electrovalves for 2 and 4-pipe systems.
- ❖ 3-way ON/OFF electrovalves for 2 and 4-pipe systems.



TOUCH CONTROL



Panel SLIM-Touch wall installation and on board.



- UVC device for air sterilisation.
- Condensate drain pan for horizontal installation.
- Back in view.
- Aesthetic and floor support feet.
- Formwork for recessed installation (only 2-pipe systems)
- Wall aesthetic panel for formwork, colour matt white RAL 9003.
- Ceiling aesthetic panel for formwork, colour matt white RAL 9003.
- Straight or 90° inlet fitting.
- 90° delivery fitting, insulated.
- Telescopic delivery fitting, insulated.
- Wall inlet grille made of aluminium, with straight profile.
- Wall mounted delivery nozzle made of aluminium, with a double row of adjustable fins.
- Ceiling inlet grille made of aluminium, with curved profile.
- Ceiling delivery nozzle made of aluminium, with curved profile.

CONTROLS

STANDARD controls

For on board installation

- Electronic board in combination with 3-speed thermostats
- Electronic board in combination with thermostats with 0-10V analogue output

For wall mounting installation

- Panel with room thermostat, summer/winter switch, speed switch and ON/OFF valve control.
- Electronic panel with automatic summer/winter switching for 2-pipe systems.

ADVANCED controls

- Wall mounting slim-touch control panel in glossy black or pearl white, with RS485 Modbus RTU interface.

For installation on machine

- ❖ Touch control on board and electronic control with continuous speed modulation, with RS485 Modbus RTU interface.
- ❖ Touch control on board and 4-speed electronic control, only for 2-pipe systems.
- ❖ Electronic control with continuous speed modulation only when combined with a KPST panel, with master/slave control up to 31 controls.

- Key: ❖ Factory fitted
 → Supplied separately





BRIO-I SLIM - MVP-MVR-IXP-IVR				10	20	25	30	40
❶ Total cooling capacity [EN1397]	MAX	kW E	0,98	1,81	2,87	3,31	3,94	
	MED	kW E	0,75	1,35	2,16	2,43	2,9	
	MIN	kW E	0,38	0,73	1,14	1,27	1,46	
❷ Heating capacity (45°C) [EN1397]	MAX	kW E	1,13	2,03	3,19	3,75	4,46	
	MED	kW E	0,81	1,48	2,32	2,75	3,11	
	MIN	kW E	0,57	0,75	0,92	1,48	1,79	
❸ Heating capacity (50°C)	MAX	kW E	1,39	2,46	3,89	4,51	5,43	
	MED	kW E	1,0	1,75	2,78	3,23	3,73	
	MIN	kW E	0,7	0,84	1,04	1,56	1,87	
❹ Heating capacity (70°C) [EN1397]	MAX	kW	2,27	4,08	6,41	7,54	9,17	
	MED	kW	1,63	2,98	4,67	5,52	6,42	
	MIN	kW	1,16	1,54	1,84	2,97	3,7	
❸ Heating capacity only radiant function (50°C) MVR-IVR version		kW	0,32	0,38	0,46	0,55	0,66	
❹ Heating capacity only radiant function (70°C) MVR-IVR version		kW	0,54	0,67	0,78	0,92	1,08	
❺ Heating capacity of additional coil (65°C) [EN1397]	MAX	kW E	0,67	1,21	1,76	2,3	2,53	
	MED	kW E	0,56	0,97	1,27	1,81	2,05	
	MIN	kW E	0,33	0,69	0,95	1,31	1,29	
❻ Heating capacity of additional coil (70°C) [EN1397]	MAX	kW E	0,78	1,44	2,18	2,77	2,88	
	MED	kW E	0,64	1,16	1,56	2,2	2,35	
	MIN	kW E	0,37	0,81	1,13	1,59	1,48	
Air flow speed	MAX	m³/h	162	320	461	576	648	
	MED	m³/h	113	252	367	453	494	
	MIN	m³/h	55	155	248	370	426	
Sound power	MAX	dB(A) E	50	51	52	54	54	
	MED	dB(A) E	42	43	45	46	46	
	MIN	dB(A) E	32	33	34	35	36	
❻ Sound pressure	MAX	dB(A)	41	42	43	45	45	
	MED	dB(A)	33	34	36	37	37	
	MIN	dB(A)	23	24	25	26	27	
Absorbed power	MAX	W E	11	19	20	28	35	
	MED	W E	9	10	13	15	17	
	MIN	W E	7	7	7	8	8	
Electrical supply		V-ph-Hz	230-1-50	230-1-50	230-1-50	230-1-50	230-1-50	
DIMENSIONS AND WEIGHTS				10	20	25	30	40
W - Width MVP-MVR		mm	723	923	1123	1323	1523	
W - Width IXP-IVR		mm	525	725	925	1125	1325	
H - Height MVP-MVR - 2T		mm	579	579	579	579	579	
H - Height IXP-IVR - 2T		mm	590	590	590	590	590	
H - Height MVP - 4T		mm	639	639	639	639	639	
H - Height IXP - 4T		mm	650	650	650	650	650	
Feet height /minimum height from floor		mm	80	80	80	80	80	
D - MVP-MVR depth		mm	149	149	149	149	149	
D - IXP-IVR depth		mm	126	126	126	126	126	
Weight MVP-MVR - 2T / MVP- 4T		kg	17 / 18	20 / 21	23 / 25	26 / 28	29 / 32	
Weight IXP-IVR - 2T / IXP - 4T		kg	9 / 10	12 / 13	15 / 17	18 / 20	21 / 24	
LxHxD - KCASE - 2T formwork		mm	715x725x142	915x725x142	1115x725x142	1315x725x142	1515x725x142	

Data at the following conditions:

- ❶ Air: 27°C D.B.; 19°C W.B. - Water: 7/12°C.
 - ❷ Air: 20°C - Water: 45/40°C.
 - ❸ Air: 20°C - Water: 50°C, flow rate as in cooling.
 - ❹ Air: 20°C - Water: 70/60°C.
 - ❺ Air: 20°C - Water: 65/55°C.
 - ❻ For room volume equal to 100 m³ and reverberation time = 0.5 sec.
- E Eurovent certified performance.

MVP-MVR per installazione verticale

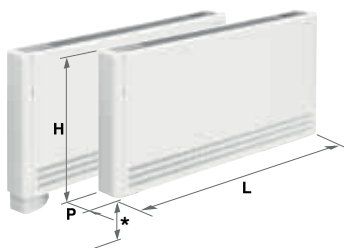

MVP-MVR+pedini * distanza da terra

MVP+KVXO per installazione orizzontale



IXP per installazione verticale e orizzontale
IVR per installazione verticale

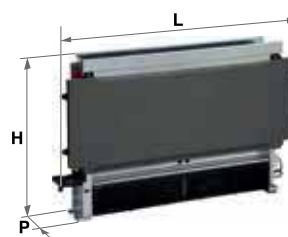

IXP-IVR con cassaforma KCASE e pannello di copertura KPCASEV



Fan coils with EC motor

COVER for BRIO-I Slim

Cooling capacity: 1.0-4.0 kW - Heating capacity: 1.1-4.6 kW

INVERTER

- Concealed fan coil installation
- Wall-flush aesthetic cover panel in white RAL 9003
- Recessed wall or false ceiling installation
- Compact size, only 14 cm thick, also with radiant function.



Installation solutions with formwork and covering panels on the wall or on the ceiling

Brio-I SLIM - Versions

- IXP - Recessed horizontal/vertical unit for wall or false ceiling installation.
- IVR - Vertical only recessed unit with front radiant function, for wall formwork installation.

Models

Brio-I SLIM: 10, 20, 25, 30, 40

Construction set-ups

Type of unit
2T - Single main coil.

ACCESSORIES for Brio COVER

- Formwork for recessed installation (only 2-pipe systems)
- Wall aesthetic panel for formwork, colour matt white RAL 9003.
- Ceiling aesthetic panel for formwork, colour matt white RAL 9003.
- Telescopic delivery fitting, insulated.
- Wall mounted delivery nozzle made of aluminium, with a double row of adjustable fins.

CONTROLS for Brio COVER

STANDARD controls

For on board installation

- Electronic board in combination with 3-speed thermostats
- Electronic board in combination with thermostats with 0-10V analogue output

For wall mounting installation

- Panel with room thermostat, summer/winter switch, speed switch and ON/OFF valve control.
- Electronic panel with automatic summer/winter switching for 2-pipe systems.

ADVANCED controls

- Slim-touch wall mounted control panel, with RS485 Modbus RTU interface.

For installation on machine

- ❖ Electronic control with continuous speed modulation only when combined with a wall mounted slim-touch panel, with master/slave control up to 31 controls.
- ❖ RS485 Modbus RTU serial interface

Key:

- ❖ Factory fitted
- Supplied separately



TOUCH CONTROL



Wall mounted SLIM-Touch panel



BRIO-I SLIM - IXP-IVR			10	20	25	30	40
❶ Total cooling capacity [EN1397]	MAX	kW E	0,98	1,81	2,87	3,31	3,94
	MED	kW E	0,75	1,35	2,16	2,43	2,9
	MIN	kW E	0,38	0,73	1,14	1,27	1,46
❷ Heating capacity (45°C) [EN1397]	MAX	kW E	1,13	2,03	3,19	3,75	4,46
	MED	kW E	0,81	1,48	2,32	2,75	3,11
	MIN	kW E	0,57	0,75	0,92	1,48	1,79
❸ Heating capacity (50°C)	MAX	kW E	1,39	2,46	3,89	4,51	5,43
	MED	kW E	1,0	1,75	2,78	3,23	3,73
	MIN	kW E	0,7	0,84	1,04	1,56	1,87
❹ Heating capacity (70°C) [EN1397]	MAX	kW	2,27	4,08	6,41	7,54	9,17
	MED	kW	1,63	2,98	4,67	5,52	6,42
	MIN	kW	1,16	1,54	1,84	2,97	3,7
❸ Heating capacity only radiant function (50°C) MVR-IVR version		kW	0,32	0,38	0,46	0,55	0,66
❹ Heating capacity only radiant function (70°C) MVR-IVR version		kW	0,54	0,67	0,78	0,92	1,08
Air flow speed	MAX	m³/h	162	320	461	576	648
	MED	m³/h	113	252	367	453	494
	MIN	m³/h	55	155	248	370	426
Sound power	MAX	dB(A) E	50	51	52	54	54
	MED	dB(A) E	42	43	45	46	46
	MIN	dB(A) E	32	33	34	35	35
❻ Sound pressure	MAX	dB(A)	41	42	43	45	45
	MED	dB(A)	33	34	36	37	37
	MIN	dB(A)	23	24	25	26	26
Absorbed power	MAX	W E	11	19	20	28	35
	MED	W E	9	10	13	15	17
	MIN	W E	7	7	7	8	8
Electrical supply	V-ph-Hz		230-1-50	230-1-50	230-1-50	230-1-50	230-1-50
DIMENSIONS AND WEIGHT			10	20	25	30	40
W - Width IXP-IVR - 2T	mm		525	725	925	1125	1325
H - Height IXP-IVR - 2T	mm		590	590	590	590	590
D - Depth IXP-IVR- 2T	mm		126	126	126	126	126
Weight IXP-IVR - 2T	kg		9	12	15	18	21
COVER for BRIO-I Slim - 2T			10	20	25	30	40
KCASE - 2T formwork	WxHxD	mm	715x725x142	915x725x142	1115x725x142	1315x725x142	1515x725x142
KCASE - 2T formwork	Weight	kg	5	6	7	8	9
KPCASEV - KPCASEO - 2T panel	WxHxD	mm	775x755x10	975x755x10	1175x755x10	1375x755x10	1575x755x10
KPCASEV - KPCASEO - 2T panel	Weight	kg	3	3,5	4	4,5	5
KGMD - 2T delivery nozzle	WxHxD	mm	335x130x6	535x130x6	735x130x6	935x130x6	1135x130x6

Data at the following conditions:

- ❶ Air: 27°C D.B.; 19°C W.B. - Water: 7/12°C.
- ❷ Air: 20°C - Water: 45/40°C.
- ❸ Air: 20°C - Water: 50°C, flow rate as in cooling.
- ❹ Air: 20°C - Water: 70/60°C.
- E Eurovent certified performance.

Per la selezione con filtro Air'Suite fare riferimento al Software di selezione UP-TO-DATE.

Cassaforma KCASE e pannello di copertura KPCASEV





YARDY

Fan coils with cabinet, to be recessed and ducted. A range that is renewed as a sign of continuity with the aim of improving the quality of the internal environment, through climate control, sound levels and air quality (IAQ) with innovative solutions, such as the Air'Suite® biocide filter.

New colour

The YARDY fan coil versions with cabinet come in a new colour: **white RAL 9003 with matt finish**, an elegant and essential colour-non-colour, which diffuses the light and opens up spaces, in line with modern design needs.



New Air'Suite® filters

The Air'Suite® biocide filter is a new exclusive wide-spectrum filtration system capable of breaking down microbiological contamination, without installing additional components. Air'Suite® filters the room air, making it healthy and clean, and breaks down microbiological agents, such as bacteria, mould and viruses, reaching a new IAQ standard (Indoor Air Quality) for indoor comfort.



With touch control

LIT-Touch is the new control platform for fan coils, completely renewed to improve the user's experience.

The new touch panel is compact and slim, and adapts to any furnishing requirement thanks to the two colour options: glossy black or pearl white, with a unique and innovative design and a simple and intuitive interface.

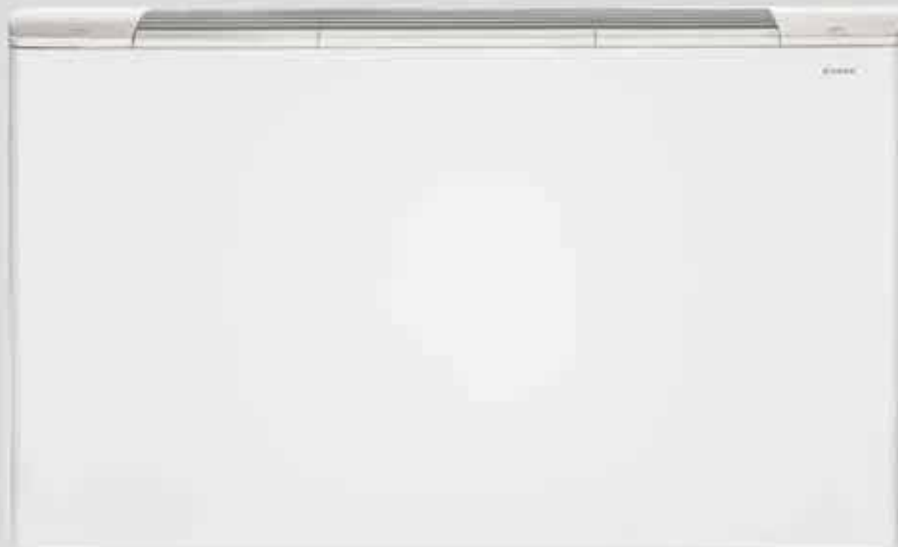

Air'Suite filter

- Inactivation of bioburden
- Minimum energy impact
- No additional maintenance
- Immediate retrofitting on existing systems
- Disposal without the risk of contamination

A new way to handle the air that we breathe every day indoors.

A new concept of biocidal filtration that allows for the removal of microbiological contamination without requiring additional solutions to be installed or existing systems to be modified.

Healthy environment

Living in a clean environment is a concept closely linked to breathing "clean air". On average, each person inhales air 16,000 times a day, so breathing in a healthy environment allows for healthy living. But what does clean air mean? Healthy? It means guaranteeing adequate thermo-hygrometric conditions, but mainly the absence of conditions that directly or indirectly affect our mental and physical state, such as odours and pathogens. In other words, a high standard of IAQ (Indoor Air Quality). Today, indoors, this need is threatened by the intensification of external pollution (promiscuity of production areas, vehicle traffic, etc.) and increased air recirculation in environments where energy saving is strategic and/or where there is no easy availability of primary air.

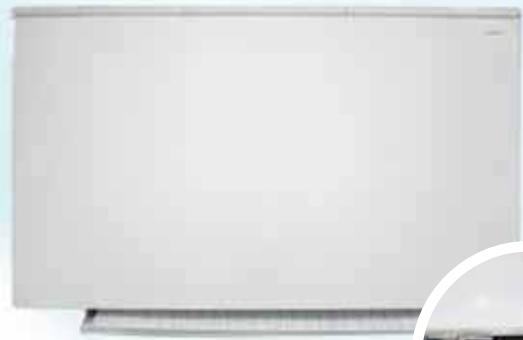

VEHICLE
TRAFFIC



PRODUCTION
FACILITIES



BIOLOGICAL
CONTAMINANTS



UNPLEASANT
ODOURS

Biocide
filtration

air'suite



Biocidal filtration

Biocidal filtration refers to a combination of granular filtration (conventional) and inactivation of the bioburden (innovative) on the same amount of air which passes through the same filtration medium. This process has been achieved by using a new, appropriately functionalised bio-polymer, characterised by:

- wide availability in nature;
- biocompatibility;
- non-toxicity;
- intrinsic infection preventing properties.

Research, development and certifications

The Air'Suite® filters were tested with new, state-of-the-art techniques that measure the actual biocide capacity on the filter surface and that do not make use of cultures but count each organism/cell and its integrity or ability to reproduce. The bacteria removal efficiency was then measured through a study protocol with IRSA-CNR certified flow cytometry techniques on a sample of the contaminated filter. The resulting efficiencies exceed 50% of "instant" removal and 100% within 30 hours after contamination.



Fields of application

There are no limits of application, however, fields and contexts that are particularly sensitive to indoor air quality, in which the new line of Air'Suite® filters finds its natural application are:

- Hospitals, clinics and nursing homes;
- Offices, meeting rooms and conference rooms;
- Waiting rooms, outpatient clinics;
- Restaurants, cafés, bars;
- Hot baths, spas;
- Swimming pools, gyms;
- Schools and kindergartens, etc.

Available types of filters

The flat Air'Suite® is a filter with filtering grade G2, pursuant to EN 779:2012 ISO Coarse 40% pursuant to EN ISO16890; it is available as an accessory for Yardy, Yardy-I, YardyDuct, Yardy-ID, and Yardy HP range versions with a cabinet, recessed and ductable (MVP-MXP-IVP-IVF-IXP-CXP).

Air'Suite® is supplied as an accessory already fitted in the unit or separately. In this case, the standard filter must simply be replaced.

Alternatively, duct installations are provided with a frame and filter that can be removed in any direction.

-> For the selection of fan coils with an Air'Suite® filter and their relative performance, refer to the selection software **UP TO DATE**.

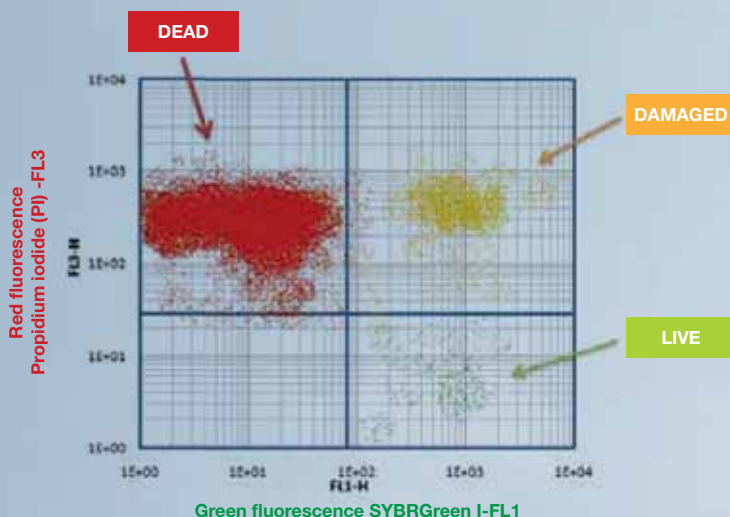

Biological removal efficiency of Air'Suite Filter



- New white RAL 9003 for versions with cabinet
- New touch controls
- Air'Suite biocide filter for healthier and cleaner air in indoor environments
- Enhanced performance with 4-row coil
- Consumption reduced by 50% with EC motor
- Continuous fan speed regulation

Fan coils with EC motor

YARDY-I EV3

Cooling capacity: 1.9-8.4 kW - Heating capacity: 2.5-11.8 kW



TOUCH CONTROL



Panel LIT-Touch wall installation and on board



LIT-Touch remote control and wall mounting receiver.



Floor and ceiling fan coil units with cabinet for recessed wall or false ceiling installation.

Construction features

- Heat exchanger: with finned coil with left side connections reversible to the right.
- Centrifugal fan with an inverter controlled electronic brushless motor and continuous speed adjustment.
- Cabinet version structure: covering cabinet in pre-painted sheet steel, RAL9003, complete with a regenerable filter, ABS polymer grilles and a natural condensate drain pan.
- Recessed version structure: in galvanised sheet steel, complete with a natural condensate drain pan and regenerable filter.

Versions

- MVP - Vertical unit with cabinet equipped with lower air inlet and upper delivery for wall mounting installation or with feet on the ground.
- MVT - Vertical unit with cabinet equipped with front air inlet and upper delivery for floor installation.
- MXP - Horizontal/vertical unit with cabinet, equipped with lower air inlet and upper delivery, for ceiling installation, wall mounted or with feet on the ground.
- MXT - Horizontal/vertical unit with cabinet, equipped with front air inlet and upper delivery, for ceiling or floor installation.
- IVP - Recessed vertical unit equipped with lower air inlet and upper delivery for wall mounting installation.
- IVF - Recessed vertical unit equipped with lower air inlet and front delivery for wall mounting installation.
- IXP - Horizontal/vertical unit equipped with lower air inlet and upper delivery for false ceiling or recessed wall installation.

Construction set-ups

Type of unit

- 2T - Single main coil.
- 4T - Double main coil and additional.

ACCESSORIES

- Additional water heating coil for 4-pipe systems.
- Electrical resistance.
- 2-way ON/OFF electrovalves for 2 and 4-pipe systems.
- 3-way ON/OFF electrovalves for 2 and 4-pipe systems.
- 4-way ON/OFF electrovalves for 4-pipe systems with single main coil.
- Auxiliary condensate drain pan.
- Air'Suite biocide filter.
- ♦ Electrical box for connection terminal block.
- ♦ Air inlet flange: Ø10cm or Ø12cm.
- Manual damper.

- Motorised damper.
- Back in view.
- Rear closing panel.
- Rear closing panel with grille and filter.
- Support feet with pipe cover.
- Flanged frame for duct connection.
- Frame with Air'Suite biocide filter (G2) that can be extracted in any direction.
- Delivery straight fitting.
- 90° delivery and inlet fitting.
- Telescopic outlet/inlet fitting.
- Inlet grille with filter.
- Delivery grille.
- Formwork for recessed wall or false ceiling installation.
- Aesthetic panel for wall mounted formwork, with air delivery and return grille.
- Aesthetic panel for formwork, with air inlet grille.
- Delivery nozzle made of aluminium, with a double row of adjustable fins.
- Anti-vibration fitting for delivery/inlet duct connection.
- Intake/outlet plenum with round nozzles.

CONTROLS

STANDARD controls

For wall mounting installation

- Electronic panel with display and RS485 serial interface, semi-recessed in wall.

Advanced LIT-TOUCH controls

- Flush LIT-Touch control panel in glossy black or pearl white for wall mounting installation.
- Wall mounted LIT-Touch remote control and receiver with air temperature probe and operation LED.
- LIT-Touch control with air temperature probe for on board installation.

For on board installation

- LIT-Touch electronic control for 2-pipe systems, with 2 pipes with electrical resistance or 4 pipes, complete with a minimum water temperature probe, ON/OFF valve control and integrated master/slave function up to a total of 15 units.
- Additional board with 2 digital outputs that can be configured.
- On board air temperature probe.
- RS485 serial board for serial communication with other devices (Modbus RTU protocol).

- Key:
- ♦ Factory fitted
 - Supplied separately





For the selection with AirSuite filter, refer to the UP-TO-DATE selection Software.

			20	24	30	34	45	48	60	74	80	88	
①	YARDY-I EV3 MVP-MVT-MXP-MXT-IVP-IVF-IXP	MAX kW E	1,86	2,24	2,97	3,37	4,11	4,6	6,28	7,33	7,94	8,4	
		MED kW E	1,44	1,68	2,33	2,75	3,05	3,49	4,6	5,24	5,87	6,32	
		MIN kW E	0,75	0,8	1,08	1,34	1,53	1,73	1,78	2,1	2,1	2,25	
②		MAX kW E	2,1	2,18	3,27	3,41	4,47	4,65	7,13	7,41	9,67	10,07	
		MED kW E	1,48	1,57	2,52	2,6	3,13	3,27	5,12	5,31	7,15	7,43	
		MIN kW E	0,77	0,81	1,2	1,26	1,5	1,57	1,88	1,94	2,63	2,74	
③		MAX kW E	2,47	2,6	3,87	4,07	5,3	5,54	8,38	8,81	11,29	11,77	
		MED kW E	1,77	1,88	2,99	3,14	3,74	3,93	6,07	6,37	8,39	8,75	
		MIN kW E	0,92	0,97	1,42	1,52	1,81	1,9	2,25	2,36	3,07	3,22	
④		MAX kW E	4,2	4,36	6,56	6,85	8,96	9,31	14,28	14,86	19,35	20,14	
		MED kW E	2,98	3,14	5,06	5,26	6,28	6,56	10,3	10,77	14,35	14,91	
		MIN kW E	1,56	1,64	2,44	2,56	3,06	3,19	3,87	3,98	5,37	5,6	
⑤		MAX kW E	1,95	2,08	2,94	2,8	3,36	3,2	5,64	5,37	6,5	6,17	
		MED kW E	1,66	1,6	2,34	2,22	2,84	2,7	4,67	4,45	5,39	5,14	
		MIN kW E	0,87	0,83	1,3	1,23	1,53	1,46	2,17	2,06	2,51	2,4	
④		MAX kW E	2,21	2,36	3,33	3,17	3,83	3,64	6,38	6,08	7,37	6,98	
		MED kW E	1,92	1,84	2,65	2,52	3,3	3,15	5,3	5,04	6,12	5,83	
		MIN kW E	1,01	0,96	1,48	1,41	1,79	1,7	2,5	2,38	2,9	2,76	
⑥		MAX m³/h	331	331	523	523	645	645	1235	1235	1503	1458	
		MED m³/h	230	230	400	400	450	450	780	780	965	965	
		MIN m³/h	97	97	167	167	198	198	256	256	300	300	
⑥		MAX dB(A) E	48	48	50	50	51	51	62	62	66	66	
		MED dB(A) E	40	40	43	43	42	42	50	50	56	56	
		MIN dB(A) E	29	29	29	29	29	29	30	30	32	32	
⑥		MAX dB(A) E	39	39	41	41	42	42	53	53	57	57	
		MED dB(A) E	31	31	34	34	33	33	41	41	47	47	
		MIN dB(A) E	20	20	20	20	20	20	21	21	23	23	
⑥		MAX W E	23	25	26	28	39	42	89	95	136	146	
		MED W E	13	14	15	16	14	15	28	30	52	56	
		MIN W E	6	6	6	6	7	8	7	7	9	10	
Electrical supply			V-ph-Hz	230-1-50	230-1-50	230-1-50	230-1-50	230-1-50	230-1-50	230-1-50	230-1-50	230-1-50	
DIMENSIONS AND WEIGHT				20	24	30	34	45	48	60	74	80	88
L - MXP-MXT-MVP-MVT width	mm	800	800	1000	1000	1200	1200	1500	1500	1500	1500	1500	
L - IVP-IXP-IVF width	mm	550	550	750	750	950	950	1250	1250	1250	1250	1250	
H - MXP-MXT-MVP-MVT height	mm	570	570	570	570	570	570	570	570	570	570	570	
H - IVP-IXP-IVF height	mm	545	545	545	545	545	545	545	545	545	545	545	
MVP-MVT-MXP-MXT Feet height	mm	100	100	100	100	100	100	100	100	100	100	100	
P - MXP-MXT-MVP-MVT Depth	mm	220	220	220	220	220	220	220	220	220	220	220	
P - IVP-IXP-IVF Depth	mm	212	212	212	212	212	212	212	212	212	212	212	
MXP-MXT-MVP-MVT Weight	kg	20	20,5	21	22	28	29	35	36	37	38		
IVP-IXP-IVF Weight	kg	16,5	17	20,5	21,5	25,5	27	34,5	35,5	36,5	37,5		

YARDY-I EV3 24 - 34 - 48 - 74 - 88 with oversized 4-row coil.

① Data at the following conditions:

② Air: 27°C D.B.; 19°C W.B. - Water: 7/12°C.

③ Air: 20°C - Water: 45/40°C.

④ Air: 20°C - Water: 50°C, flow rate as in cooling.

⑤ Air: 20°C - Water: 70/60°C.

⑥ Air: 20°C - Water: 65/55°C.

E For room volume equal to 100 m³ and reverberation time = 0.5 sec.

Eurovent certified performance.

Performance refers to the motor's input signal: 10V - 6V - 1V at MAX - MED - MIN speed.

MXP per installazione orizzontale

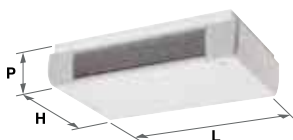

MXT per installazione orizzontale



MVP-MXP per installazione verticale



MVT-MXT per installazione verticale

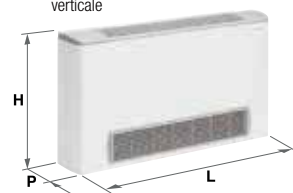

IXP per installazione orizzontale

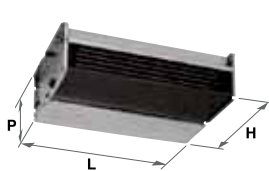

IVP-IXP per installazione verticale



IVF per installazione verticale

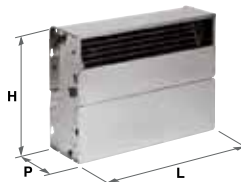

Web code: **YARV3**Web code accessories: **ACMEC**Web code controls: **ACREG**

Fan coils

YARDY EV3

Cooling capacity: 1.0-8.3 kW - Heating capacity: 1.4-11.7 kW



TOUCH CONTROL



Panel
LIT-Touch
wall installation
and on board



LIT-Touch
remote
control
and wall
mounting
receiver.

air'suite

- New white RAL 9003 for versions with cabinet
- New touch controls
- Air'Suite biocide filter for healthier and cleaner air in indoor environments
- Enhanced performance with 4-row coil
- 6-speed fan
- Pre-fitted accessories and controls

Floor and ceiling fan coil units with cabinet for recessed wall or false ceiling installation.

Construction features

- Heat exchanger: with finned coil with left side connections reversible to the right.
- Centrifugal fan: 6 speeds, 3 of which are connected to the terminal block.
- Cabinet version structure: covering cabinet in pre-painted sheet steel, RAL9003, complete with regenerable filter, ABS polymer grilles and natural condensate drain pan.
- Recessed version structure: in galvanised sheet steel, complete with a natural condensate drain pan and regenerable filter.

Versions

- MVP - Vertical unit with cabinet equipped with lower air inlet and upper delivery for wall mounting installation or with feet on the ground.
- MVT - Vertical unit with cabinet equipped with front air inlet and upper delivery for floor installation.
- MXP - Horizontal/vertical unit with cabinet, equipped with lower air inlet and upper delivery, for ceiling installation, wall mounted or with feet on the ground.
- MXT - Horizontal/vertical unit with cabinet, equipped with front air inlet and upper delivery, for ceiling or floor installation.
- IVP - Recessed vertical unit equipped with lower air inlet and upper delivery for wall mounting installation.
- IVF - Recessed vertical unit equipped with lower air inlet and front delivery for wall mounting installation.
- IXP - Horizontal/vertical unit equipped with lower air inlet and upper delivery for false ceiling or recessed wall installation.

Construction set-ups

Type of unit

- 2T - Single main coil.
- 4T - Double main coil and additional.

ACCESSORIES

- ❖ Additional water heating coil for 4-pipe systems.
- ❖ Electrical resistance.
- ❖2 -way ON/OFF electrovalves for 2 and 4-pipe systems.
- ❖3 -way ON/OFF electrovalves for 2 and 4-pipe systems.
- ❖4-way ON/OFF electrovalves for 4-pipe systems with a single main coil.
- ❖Auxiliary condensate drain pan.
- ❖Air'Suite biocide filter.
- ❖ Electrical box for connection terminal block.
- ❖ Air inlet flange: Ø10cm or Ø12cm.
- Manual damper.
- Motorised damper.
- Back in view.
- Rear closing panel.
- Rear closing panel with grille and filter.
- Support feet with pipe cover.
- Flanged frame for duct connection.
- Frame with Air'Suite biocide filter (G2) that can be extracted in any direction.
- Delivery straight fitting.
- 90° delivery and inlet fitting.
- Telescopic outlet/inlet fitting.
- Inlet grille with filter.
- Delivery grille.
- Formwork for recessed wall or false ceiling installation.
- Aesthetic panel for wall mounted formwork, with air delivery and return grille for wall mounting installation.



YARDY EV3 MVP-MVT-MXP-MXT-IVP-IVF-IXP		15	20	24	25	30	34	40	45	48	55	58	60	74	80	88
L - MXP-MXT-MVP-MVT width	mm	700	800	800	1000	1000	1000	1200	1200	1200	1500	1500	1500	1500	1500	1500
L - IVP-IXP-IVF width	mm	450	550	550	750	750	750	950	950	950	1250	1250	1250	1250	1250	1250
H - MXP-MXT-MVP-MVT height	mm	570	570	570	570	570	570	570	570	570	570	570	570	570	570	570
H - IVP-IXP-IVF height	mm	545	545	545	545	545	545	545	545	545	545	545	545	545	545	545
MVP-MVT-MXP-MXT Feet height	mm	100	100	100	100	100	100	100	100	100	100	100	100	100	100	100
P - MXP-MXT-MVP-MVT Depth	mm	220	220	220	220	220	220	220	220	220	220	220	220	220	220	220
P - IVP-IXP-IVF Depth	mm	212	212	212	212	212	212	212	212	212	212	212	212	212	212	212
MXP-MXT-MVP-MVT Weight	kg	16	20	20,5	20	21	22	27	28	29	35	35	35	36	37	38
IVP-IXP-IVF Weight	kg	14,5	16,5	17	20,5	20,5	21,5	24	25,5	27	34,5	34,5	34,5	35,5	36,5	37,5

- Aesthetic panel for formwork, with air inlet grille for wall mounting or ceiling installation.
- Delivery nozzle made of aluminium, with a double row of adjustable fins.
- Anti-vibration fitting for delivery/inlet duct connection.
- Intake/outlet plenum with round nozzles.

CONTROLS

STANDARD controls

For wall mounting installation

- Panel with speed and summer/winter switch.
- Panel with room thermostat, summer/winter switch, speed switch, ON/OFF valve control and electrical resistance.
- ☒ Minimum temperature thermostat (for installation on machine).
- Electronic panel with automatic summer/winter switching for 2-pipe systems.
- Electronic panel with automatic summer/winter switching and automatic speed adjustment for 2-pipe systems with electrical resistance or 4-pipe systems.
- Electronic panel with display and RS485 serial interface, semi-recessed in wall.

For on board installation (MVP and MVT versions)

- Panel with speed switch.
- Panel with room thermostat, summer/winter switch and speed switch.
- Minimum temperature thermostat.
- Panel with room thermostat, summer/winter switch, speed switch, ON/OFF valve control and electrical resistance.
- Electronic panel with automatic summer/winter switching for 2-pipe systems.
- Electronic panel with automatic summer/winter switching and automatic speed adjustment for 2-pipe systems with electrical resistance or 4-pipe systems.
- Interface board to control up to 4 fan coils.

Advanced LIT-TOUCH controls

- ☒ Flush LIT-Touch control panel in glossy black or pearl white for wall mounting installation.
- Wall mounted LIT-Touch remote control and receiver with air temperature probe and operation LED.
- LIT-Touch control with air temperature probe for on board installation.

For on board installation

- ☒☒ LIT-Touch electronic control for 2-pipe systems, with 2 pipes with electrical resistance or 4 pipes, complete with minimum water temperature probe, ON/OFF valve control and

integrated master/slave function up to a total of 15 units.
 → Additional board with 2 digital outputs that can be configured.
 → On board air temperature probe.
 → RS485 serial board for serial communication with other devices (Modbus RTU protocol).

Key: ♦ Factory fitted
 → Supplied separately

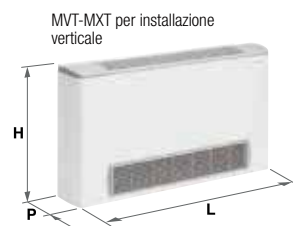
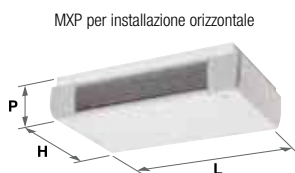

YARDY EV3 MVP-MVT-MXP-MXT-IVF-IXP		15	20	24	25	30	34	40	45	48	55	58	60	74	80	88	
1	Total cooling capacity [EN1397]	VI	kW 1,1	1,98	2,2	2,5	3,21	3,28	3,72	4,26	4,76	5,38	5,9	6,53	6,99	7,82	8,25
		V	kW 1,04	1,76	2,1	2,24	2,8	3,05	3,36	3,84	4,46	4,86	5,24	6,09	6,48	7,52	7,93
		IV	kW 0,96	1,54	1,87	2,02	2,57	2,81	2,84	3,31	3,57	4,4	4,76	5,42	6,01	7,12	7,39
		III	kW 0,89	1,37	1,68	1,69	2,46	2,55	2,63	2,99	3,35	3,9	4,23	5,26	5,68	6,77	7,32
		II	kW 0,76	1,18	1,45	1,62	2,07	2,25	2,47	2,81	3,11	3,34	3,57	4,4	5,05	6,31	6,83
		I	kW 0,64	1,13	1,35	1,38	1,78	1,98	2,06	2,49	2,85	2,69	3,03	4,22	4,63	6,24	6,49
2	Heating capacity (45°C) [EN1397]	VI	kW 1,38	2,26	2,36	2,97	3,59	3,77	4,37	4,68	4,89	6,13	7,18	7,53	7,89	8,71	10,04
		V	kW 1,21	1,97	2,04	2,68	3,29	3,45	3,79	4,27	4,45	5,46	6,74	7,04	7,37	8,25	9,61
		IV	kW 1,08	1,62	1,73	2,3	2,85	2,98	3,22	3,47	3,64	4,89	5,93	6,2	6,48	8,16	9,12
		III	kW 1,06	1,47	1,52	1,94	2,66	2,79	2,98	3,21	3,34	4,13	5,81	6,02	6,29	7,8	9
		II	kW 0,92	1,26	1,44	1,85	2,26	2,35	2,77	2,81	2,93	3,57	5,12	5,29	5,49	7,12	8,22
		I	kW 0,7	1,24	1,27	1,57	2,02	2,2	2,52	2,59	2,69	2,94	4,6	4,71	4,91	7,05	8,15
3	Heating capacity (50°C)	VI	kW 1,59	2,65	2,78	3,47	4,21	4,42	5,11	5,51	5,79	7,17	8,34	8,78	9,22	10,19	11,68
		V	kW 1,4	2,31	2,43	3,14	3,85	4,04	4,45	5,03	5,28	6,39	7,81	8,22	8,63	9,67	11,17
		IV	kW 1,25	1,91	2,06	2,71	3,36	3,53	3,79	4,11	4,32	5,74	6,89	7,25	7,61	9,55	10,62
		III	kW 1,23	1,74	1,83	2,28	3,14	3,3	3,5	3,79	3,98	4,87	6,69	7,04	7,39	9,13	10,49
		II	kW 1,07	1,49	1,72	2,18	2,67	2,8	3,26	3,35	3,52	4,22	5,85	6,16	6,47	8,35	9,6
		I	kW 0,82	1,46	1,53	1,84	2,37	2,59	2,93	3,08	3,23	3,47	5,24	5,52	5,8	8,27	9,49
4	Heating capacity (70°C) [EN1397]	VI	kW 2,74	4,52	4,71	5,94	7,17	7,54	8,75	9,34	9,77	12,25	14,33	15,02	15,74	17,38	20,04
		V	kW 2,4	3,93	4,08	5,37	6,58	6,88	7,59	8,53	8,88	10,9	13,46	14,05	14,72	16,47	19,16
		IV	kW 2,13	3,23	3,45	4,61	5,71	5,97	6,46	6,93	7,27	9,78	11,84	12,38	12,93	16,31	18,22
		III	kW 2,11	2,95	3,06	3,88	5,32	5,61	5,96	6,4	6,69	8,26	11,61	12,02	12,58	15,6	17,99
		II	kW 1,84	2,54	2,89	3,71	4,53	4,76	5,57	5,63	5,89	7,17	10,25	10,56	11,06	14,24	16,44
		I	kW 1,4	2,5	2,57	3,15	4,06	4,44	5,05	5,19	5,42	5,97	9,27	9,45	9,95	14,1	16,29
5	Heating capacity of additional coil (65°C) [EN1397]	VI	kW 1,37	2,09	1,78	2,7	3,2	3,05	3,68	3,5	3,34	5,46	5,13	5,7	5,45	6,51	6,27
		V	kW 1,14	1,92	1,69	2,61	2,69	2,56	2,94	3,38	3,22	5,15	5	5,56	5,28	6,46	6,2
		IV	kW 1,19	1,81	1,46	2,28	2,61	2,48	2,9	2,96	2,82	4,6	4,68	5,21	4,96	6,36	6,07
		III	kW 0,96	1,51	1,33	2	2,28	2,17	2,81	2,79	2,65	4,27	4,34	4,91	4,62	5,9	5,92
		II	kW 0,96	1,4	1,2	1,84	2,15	2,04	2,76	2,74	2,6	3,58	3,72	4,71	3,96	5,7	5,75
		I	kW 0,79	1,29	1,16	1,69	1,93	1,83	2,62	2,21	2,15	3,16	3,25	4,22	3,53	5,3	5,28
4	Heating capacity of additional coil (70°C) [EN1397]	VI	kW 1,49	2,37	2,01	3,06	3,62	3,45	4,18	3,98	3,79	6,2	5,81	6,45	6,15	7,36	7,08
		V	kW 1,33	2,2	1,93	2,95	3,04	2,9	3,46	3,84	3,66	5,83	5,66	6,29	5,98	7,31	7,01
		IV	kW 1,29	2,09	1,7	2,59	2,95	2,8	3,36	3,46	3,27	5,22	5,3	5,9	5,61	7,2	6,86
		III	kW 1,12	1,75	1,56	2,27	2,58	2,46	3,33	3,25	3,07	4,84	4,92	5,57	5,23	6,69	6,7
		II	kW 1,04	1,63	1,4	2,12	2,43	2,31	3,26	3,2	3,02	4,16	4,25	5,34	4,48	6,46	6,51
		I	kW 0,91	1,5	1,34	1,92	2,19	2,06	3,07	2,59	2,53	3,63	3,73	4,78	3,99	6,02	5,98
Air flow speed	VI	m³/h 229	339	339	484	547	547	676	681	681	1077	1077	1235	1235	1480	1480	
	V	m³/h 209	288	288	405	483	483	587	627	627	916	916	1109	1109	1388	1388	
	IV	m³/h 183	238	238	339	434	434	472	474	474	802	802	948	948	1220	1220	
	III	m³/h 163	207	207	281	383	383	419	431	431	662	662	882	882	1171	1171	
	II	m³/h 138	177	177	252	329	321	390	392	392	537	537	757	757	1031	1031	
	I	m³/h 100	155	155	217	281	281	365	338	338	420	420	672	672	994	994	
Sound power	VI	dB(A) 46	48	48	48	50	50	51	52	52	58	58	62	62	66	66	
	V	dB(A) 43	44	44	42	46	47	48	50	50	56	56	60	60	65	65	
	IV	dB(A) 40	41	40	38	43	43	43	43	43	52	54	56	56	62	62	
	III	dB(A) 37	38	35	33	40	40	40	41	41	47	47	54	54	61	61	
	II	dB(A) 32	34	32	30	36	36	38	38	38	41	41	50	50	59	59	
	I	dB(A) 29	30	31	26	35	34	35	35	35	36	36	48	48	57	57	
6	Sound pressure	VI	dB(A) 37	39	39	39	41	41	42	43	43	49	49	53	53	57	57
		V	dB(A) 34	35	35	33	37	38	39	41	41	47	47	51	51	56	56
		IV	dB(A) 31	32	31	29	34	34	34	34	34	43	45	47	47	53	53
		III	dB(A) 28	29	26	24	31	31	31	32	32	38	38	45	45	52	52
		II	dB(A) 23	25	23	21	27	27	29	29	29	32	32	41	41	50	50
		I	dB(A) 20	21	22	17	26	25	26	26	26	27	27	39	39	48	48
Absorbed power	VI	W 40	40	41	56	60	65	72	70	76	115	145	161	172	184	197	
	V	W 39	36	32	42	54	58	58	61	66	95	122	130	133	173	185	
	IV	W 31	25	25	32	36	39	42	41	44	81	102	117	125	142	152	
	III	W 28	23	21	27	31	33	34	36	39	66	83	109	117	133	142	
	II	W 23	17	16	21	27	27	33	31	33	51	64	95	102	124	133	
	I	W 17	15	14	20	25	25	28	28	30	41	44	92	98	116	124	
Electrical supply	V-ph-Hz		230-1-50														

Data at the following conditions:

- 1 Air: 27°C D.B.; 19°C W.B. - Water: 7/12°C.
- 2 Air: 20°C - Water: 45/40°C.
- 3 Air: 20°C - Water: 50°C, flow rate as in cooling.
- 4 Air: 20°C - Water: 70/60°C.
- 5 Air: 20°C - Water: 65/55°C.

6 For room volume equal to 100 m³ and reverberation time = 0.5 sec.

• Wired speed in terminal block.

E Eurovent certified performance.

Yardy EV3 24 - 34 - 48 - 74 - 88 with oversized 4-row coil.

For the selection with Air'Suite filter, refer to the UP-TO-DATE selection Software.



COVER

Installation solutions with formwork and covering panels on the wall or on the ceiling. A simple and elegant way to hide the visible fan coil, eliminate clutter and free the wall.



New concealed solutions

COVER allows for the recessed installation of the YARDY, YARDY-I and Brio-I Slim fan coils and covering with flush aesthetic finishing panels, in matt white RAL 9003.

The wall solution includes wall-mounted formwork and a covering panel consisting of a frame, a grille with fixed inlet fins and an air outlet opening with an adjustable 180° flap. The formwork requires the necessary technical space for easy installation of the fan coil and comes complete with an internal grille, which prevents access to the technical compartment, for total safety of use.



New Air'Suite® filters

The Air'Suite® biocide filter, which is available for Yardy with a COVER, is a new exclusive wide-spectrum filtration system capable of breaking down microbiological contamination, without installing additional components.

Air'Suite® filters the room air, making it healthy and clean, and breaks down microbiological agents, such as bacteria, mould and viruses, reaching a new IAQ standard (Indoor Air Quality) for indoor comfort.



COVER for Yardy is available in 3 sizes for 2 and 4-pipe systems; COVER for Brio-I Slim is available in 5 sizes for 2-pipe systems, also with a front radial effect.



Web code: **YARV3 - YARI3**Web code accessories: **ACMEC**Web code controls: **ACREG**

Fan coils

COVER for YARDY

Cooling capacity: 1.8-4.8 kW - Heating capacity: 2.3-5.8 kW



- Concealed fan coil installation
- Wall-flush aesthetic cover panel in white RAL 9003
- Recessed wall or false ceiling installation

TOUCH CONTROL



Panel
Wall
mounted
LIT-Touch
panel.

LIT-Touch
remote
control
and wall
mounting
receiver.



Installation solutions with formwork and covering panels on the wall or on the ceiling

Yardy EV3 and Yardy-I EV3 - Versions

- IVP - Recessed vertical unit equipped with lower air inlet and upper delivery for wall mounting installation.
- IXP - Horizontal/vertical unit equipped with lower air inlet and upper delivery for false ceiling or recessed wall installation.

Yardy-ID2 and YardyDUCT2 - Version

- CXP - Ducted recessed unit for horizontal or vertical installation (with lower return and upper delivery).

Models

Yardy-I EV3: 20, 24, 30, 34, 45, 48

Yardy EV3: 20, 24, 25, 30, 34, 40, 45, 48

Yardy-ID2: 40, 48

YardyDUCT2: 40, 48

Construction set-ups

Type of unit

2T - Single main coil.

4T - Double main coil and additional.

ACCESSORIES for Yardy COVER

- Formwork for recessed wall or false ceiling installation
- Aesthetic panel for wall mounted formwork, colour matt white RAL 9003, with air delivery and return grille for wall mounting installation (IVP and IXP version only).
- Aesthetic panel for formwork, colour matt white RAL 9003, with air inlet grille for wall mounting or ceiling installation
- Delivery nozzle made of aluminium, with a double row of adjustable fins

CONTROLS for Yardy COVER

STANDARD controls

For wall mounting installation

- Panel with speed and summer/winter switch.
- Panel with room thermostat, summer/winter switch, speed switch, ON/OFF valve control and electrical resistance.
- Minimum temperature thermostat (for installation on machine).
- Electronic panel with automatic summer/winter switching for 2-pipe systems.
- Electronic panel with automatic summer/winter switching and automatic speed adjustment for 2-pipe systems with electrical resistance or 4-pipe systems.
- Electronic panel with display and RS485 serial interface, semi-recessed in wall.

Advanced LIT-TOUCH controls

- Flush LIT-Touch control panel in glossy black or pearl white for wall mounting installation.
- Wall mounted LIT-Touch remote control and receiver with air temperature probe and operation LED.

For on board installation

- ❖ LIT-Touch electronic control for 2-pipe systems, with 2 pipes with electrical resistance or 4 pipes, complete with minimum water temperature probe, ON/OFF valve control and integrated master/slave function up to a total of 15 units.
- ❖ Additional board with 2 digital outputs that can be configured.
- ❖ On board air temperature probe.
- ❖ RS485 serial board for serial communication with other devices (Modbus RTU protocol).



YARDY-I EV3 IVP-IXP				20	24	30	34	45	48
❶ Total cooling capacity [EN1397]	MAX	kW	E	1,86	2,24	2,97	3,37	4,11	4,6
	MED	kW	E	1,44	1,68	2,33	2,75	3,05	3,49
	MIN	kW	E	0,75	0,8	1,08	1,34	1,53	1,73
❷ Heating capacity (45°C) [EN1397]	MAX	kW	E	2,1	2,18	3,27	3,41	4,47	4,65
	MED	kW	E	1,48	1,57	2,52	2,6	3,13	3,27
	MIN	kW	E	0,77	0,81	1,2	1,26	1,5	1,57
❸ Heating capacity (50°C)	MAX	kW	E	2,47	2,6	3,87	4,07	5,3	5,54
	MED	kW	E	1,77	1,88	2,99	3,14	3,74	3,93
	MIN	kW	E	0,92	0,97	1,42	1,52	1,81	1,9
❹ Heating capacity (70°C) [EN1397]	MAX	kW		4,2	4,36	6,56	6,85	8,96	9,31
	MED	kW		2,98	3,14	5,06	5,26	6,28	6,56
	MIN	kW		1,56	1,64	2,44	2,56	3,06	3,19
❺ Heating capacity of additional coil (65°C) [EN1397]	MAX	kW	E	1,95	2,08	2,94	2,8	3,36	3,2
	MED	kW	E	1,66	1,6	2,34	2,22	2,84	2,7
	MIN	kW	E	0,87	0,83	1,3	1,23	1,53	1,46
❻ Heating capacity of additional coil (70°C) [EN1397]	MAX	kW	E	2,21	2,36	3,33	3,17	3,83	3,64
	MED	kW	E	1,92	1,84	2,65	2,52	3,3	3,15
	MIN	kW	E	1,01	0,96	1,48	1,41	1,79	1,7
Air flow speed	MAX	m³/h		331	331	523	523	645	645
	MED	m³/h		230	230	400	400	450	450
	MIN	m³/h		97	97	167	167	198	198
Sound power	MAX	dB(A)	E	48	48	50	50	51	51
	MED	dB(A)	E	40	40	43	43	42	42
	MIN	dB(A)	E	29	29	29	29	29	29
❷ Sound pressure	MAX	dB(A)		39	39	41	41	42	42
	MED	dB(A)		31	31	34	34	33	33
	MIN	dB(A)		20	20	20	20	20	20
Absorbed power	MAX	W	E	23	25	26	28	39	42
	MED	W	E	13	14	15	16	14	15
	MIN	W	E	6	6	6	6	7	8
Electrical supply	V-ph-Hz		230-1-50	230-1-50	230-1-50	230-1-50	230-1-50	230-1-50	
DIMENSIONS AND WEIGHT				20	24	30	34	45	48
L - IVP-IXP Width	mm		550	550	750	750	950	950	
H - IVP-IXP Height	mm		545	545	545	545	545	545	
P - IVP-IXP Depth	mm		212	212	212	212	212	212	
IVP-IXP Weight	kg		16,5	17	20,5	21,5	25,5	27	
COVER for Yardy-I				20	24	30	34	45	48
KCASE formwork	WxHxD	mm	920x790x225	920x790x225	1125x790x225	1125x790x225	1325x790x225	1325x790x225	
KCASE formwork	Weight	kg	13	13	15	15	17	17	
KPVCASE - KPVCASE panel	WxHxD	mm	975x820x10	975x820x10	1175x820x10	1175x820x10	1375x820x10	1375x820x10	
KPVCASE - KPVCASE panel	Weight	kg	9	9	10	10	11	11	
KGMD delivery nozzle	WxHxD	mm	555x205x6	555x205x6	755x205x6	755x205x6	955x205x6	955x205x6	

Data at the following conditions:

- ❶ Air: 27°C D.B.; 19°C W.B. - Water: 7/12°C.
- ❷ Air: 20°C - Water: 45/40°C.
- ❸ Air: 20°C - Water: 50°C, flow rate as in cooling.
- ❹ Air: 20°C - Water: 70/60°C.
- ❺ Air: 20°C - Water: 65/55°C.
- ❻ For room volume equal to 100 m³ and reverberation time = 0.5 sec.

E Eurovent certified performance.

Performance refers to the motor's input signal: 10V - 6V - 1V at MAX - MED - MIN speed.
YARDY-I EV3 24 - 34 - 48 - 74 - 88 with oversized 4-row coil.

For the selection with Air'Suite filter, refer to the UP-TO-DATE selection Software.

Cassaforma KCASE e pannello di copertura KPVCASE



Fan coils

COVER for YARDY

YARDY EV3 IVP-IXP		20	24	25	30	34	40	45	48	
1 Total cooling capacity [EN1397]	VI	kW	1,98	2,2	2,5	3,21	3,28	3,72	4,26	4,76
	V	kW	1,76	2,1	2,24	2,8	3,05	3,36	3,84	4,46
	IV	kW	1,54	1,87	2,02	2,57	2,81	2,84	3,31	3,57
	III	kW	1,37	1,68	1,69	2,46	2,55	2,63	2,99	3,35
	II	kW	1,18	1,45	1,62	2,07	2,25	2,47	2,81	3,11
	I	kW	1,13	1,35	1,38	1,78	1,98	2,06	2,49	2,85
2 Heating capacity (45°C) [EN1397]	VI	kW	2,26	2,36	2,97	3,59	3,77	4,37	4,68	4,89
	V	kW	1,97	2,04	2,68	3,29	3,45	3,79	4,27	4,45
	IV	kW	1,62	1,73	2,3	2,85	2,98	3,22	3,47	3,64
	III	kW	1,47	1,52	1,94	2,66	2,79	2,98	3,21	3,34
	II	kW	1,26	1,44	1,85	2,26	2,35	2,77	2,81	2,93
	I	kW	1,24	1,27	1,57	2,02	2,2	2,52	2,59	2,69
3 Heating capacity (50°C)	VI	kW	2,65	2,78	3,47	4,21	4,42	5,11	5,51	5,79
	V	kW	2,31	2,43	3,14	3,85	4,04	4,45	5,03	5,28
	IV	kW	1,91	2,06	2,71	3,36	3,53	3,79	4,11	4,32
	III	kW	1,74	1,83	2,28	3,14	3,3	3,5	3,79	3,98
	II	kW	1,49	1,72	2,18	2,67	2,8	3,26	3,35	3,52
	I	kW	1,46	1,53	1,84	2,37	2,59	2,93	3,08	3,23
4 Heating capacity (70°C) [EN1397]	VI	kW	4,52	4,71	5,94	7,17	7,54	8,75	9,34	9,77
	V	kW	3,93	4,08	5,37	6,58	6,88	7,59	8,53	8,88
	IV	kW	3,23	3,45	4,61	5,71	5,97	6,46	6,93	7,27
	III	kW	2,95	3,06	3,88	5,32	5,61	5,96	6,4	6,69
	II	kW	2,54	2,89	3,71	4,53	4,76	5,57	5,63	5,89
	I	kW	2,5	2,57	3,15	4,06	4,44	5,05	5,19	5,42
5 Heating capacity of additional coil (65°C) [EN1397]	VI	kW	2,09	1,78	2,7	3,2	3,05	3,68	3,5	3,34
	V	kW	1,92	1,69	2,61	2,69	2,56	2,94	3,38	3,22
	IV	kW	1,81	1,46	2,28	2,61	2,48	2,9	2,96	2,82
	III	kW	1,51	1,33	2	2,28	2,17	2,81	2,79	2,65
	II	kW	1,4	1,2	1,84	2,15	2,04	2,76	2,74	2,6
	I	kW	1,29	1,16	1,69	1,93	1,83	2,62	2,21	2,15
4 Heating capacity of additional coil (70°C) [EN1397]	VI	kW	2,37	2,01	3,06	3,62	3,45	4,18	3,98	3,79
	V	kW	2,2	1,93	2,95	3,04	2,9	3,46	3,84	3,66
	IV	kW	2,09	1,7	2,59	2,95	2,8	3,36	3,46	3,27
	III	kW	1,75	1,56	2,27	2,58	2,46	3,33	3,25	3,07
	II	kW	1,63	1,4	2,12	2,43	2,31	3,26	3,2	3,02
	I	kW	1,5	1,34	1,92	2,19	2,06	3,07	2,59	2,53
Air flow speed	VI	m³/h	339	339	484	547	547	676	681	681
	V	m³/h	288	288	405	483	483	587	627	627
	IV	m³/h	238	238	339	434	434	472	474	474
	III	m³/h	207	207	281	383	383	419	431	431
	II	m³/h	177	177	252	329	321	390	392	392
	I	m³/h	155	155	217	281	281	365	338	338
Sound power	VI	dB(A)	48	48	48	50	50	51	52	52
	V	dB(A)	44	44	42	46	47	48	50	50
	IV	dB(A)	41	40	38	43	43	43	43	43
	III	dB(A)	38	35	33	40	40	40	41	41
	II	dB(A)	34	32	30	36	36	38	38	38
	I	dB(A)	30	31	26	35	34	35	35	35
6 Sound pressure	VI	dB(A)	39	39	39	41	41	42	43	43
	V	dB(A)	35	35	33	37	38	39	41	41
	IV	dB(A)	32	31	29	34	34	34	34	34
	III	dB(A)	29	26	24	31	31	31	32	32
	II	dB(A)	25	23	21	27	27	29	29	29
	I	dB(A)	21	22	17	26	25	26	26	26
Absorbed power	VI	W	40	41	56	60	65	72	70	76
	V	W	36	32	42	54	58	58	61	66
	IV	W	25	25	32	36	39	42	41	44
	III	W	23	21	27	31	33	34	36	39
	II	W	17	16	21	27	27	33	31	33
	I	W	15	14	20	25	25	28	28	30
Electrical supply		V-ph-Hz	230-1-50	230-1-50	230-1-50	230-1-50	230-1-50	230-1-50	230-1-50	230-1-50

Data at the following conditions:

1 Air: 27°C D.B.; 19°C W.B. - Water: 7/12°C.

2 Air: 20°C - Water: 45/40°C.

3 Air: 20°C - Water: 50°C, flow rate as in cooling.

4 Air: 20°C - Water: 70/60°C.

5 Air: 20°C - Water: 65/55°C.

6 For room volume equal to 100 m³ and reverberation time = 0.5 sec.

· Wired speed in terminal block.

E Eurovent certified performance.

Yardy EV3 24 - 34 - 48 - 74 - 88 with oversized 4-row coil.

For the selection with Air'Suite filter, refer to the UP-TO-DATE selection Software.

Cassaforma KCASE e pannello di copertura KPVCASE



YARDY EV3 IVP-IXP		20	24	25	30	34	40	45	48
L - IVP-IXP Width	mm	550	550	750	750	750	950	950	950
H - IVP-IXP Height	mm	545	545	545	545	545	545	545	545
P - IVP-IXP Depth	mm	212	212	212	212	212	212	212	212
IVP-IXP Weight	kg	16,5	17	20,5	20,5	21,5	24	25,5	27
COVER for Yardy		20	24	25	30	34	40	45	48
KCASE formwork	WxHxD	mm 920x790x225	920x790x225	1125x790x225	1125x790x225	1125x790x225	1325x790x225	1325x790x225	1325x790x225
KCASE formwork	Weight	kg 13	13	15	15	15	17	17	17
KPVCASE - KPXCASE panel	WxHxD	mm 975x820x10	975x820x10	1175x820x10	1175x820x10	1175x820x10	1375x820x10	1375x820x10	1375x820x10
KPVCASE - KPXCASE panel	Weight	kg 9	9	10	10	10	11	11	11
KGMD delivery nozzle	WxHxD	mm 555x205x6	555x205x6	755x205x6	755x205x6	755x205x6	955x205x6	955x205x6	955x205x6

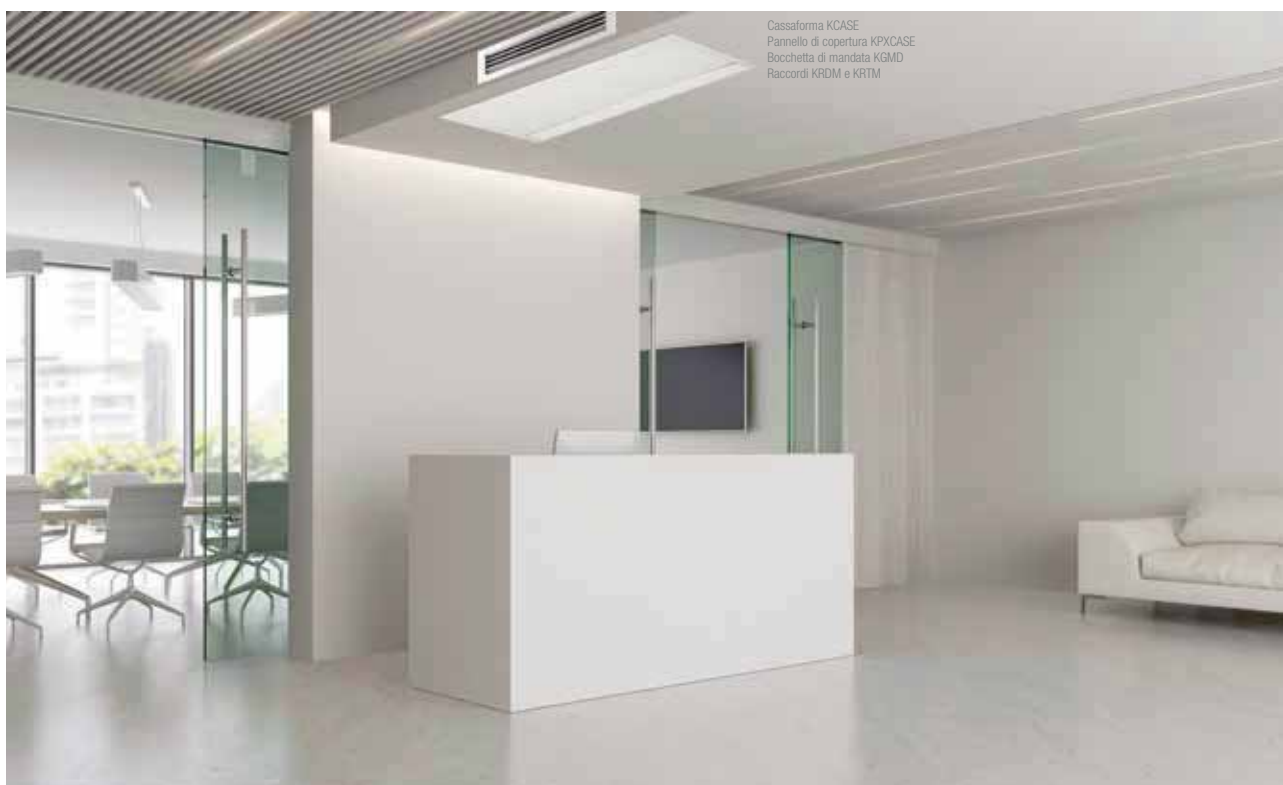

Cassafanica KCASE
Pannello di copertura KPXCASE
Bocchetta di mandata KGMD
Raccordi KRDM e KRIM



INVERTER

air'suite

- **Air'Suite biocide filter for healthier and cleaner air in indoor environments**
- **New touch controls**
- **Enhanced performance with 4-row coil**
- **Consumption reduced by 50% with EC motor**
- **Continuous fan speed regulation**
- **Horizontal and vertical installation**

Ducted fan coils with EC motor

YARDY-ID2

Cooling capacity: 3.0-6.3 kW - Heating capacity: 3.9-8.7 kW



TOUCH CONTROL



Panel LIT-Touch wall-mounted.

LIT-Touch remote control and wall mounting receiver.



Ducted fan coils for recessed horizontal or vertical installation.

Construction features

- Heat exchanger: with finned coil with left side connections reversible to the right.
- Centrifugal fan: with an inverter controlled electronic brushless motor and continuous speed adjustment.
- Structure: made of galvanised sheet steel complete with a natural condensate drain pan and regenerable filter.

Versions

- CXP - Recessed unit for horizontal or vertical installation (with lower return and upper delivery).

Construction set-ups

Type of unit

- 2T - Single main coil
- 4T - Double main coil and additional

ACCESSORIES

- ❖ Additional water heating coil for 4-pipe systems.
- ❖ Electrical resistance.
- ❖ 2 -way ON/OFF electrovalves for 2 and 4-pipe systems.
- ❖ 3 -way ON/OFF electrovalves for 2 and 4-pipe systems.
- ❖ 4-way ON/OFF electrovalves for 4-pipe systems with single main coil.
- ❖ Auxiliary condensate drain pan.
- ❖ Air'Suite biocide filter.
- ❖ Electrical box for connection terminal block.
- ❖ Air inlet flange: Ø10cm or Ø12cm.
- Flanged frame for connection to intake or delivery duct.

- Frame with Air'Suite biocide filter (G2) that can be extracted in any direction.
- Delivery straight fitting.
- 90° delivery and inlet fitting.
- Telescopic outlet/inlet fitting.
- Inlet grille with filter.
- Delivery grille.
- Formwork for recessed wall or false ceiling installation.
- Aesthetic panel for formwork, with air inlet grille for wall mounting or ceiling installation.
- Delivery nozzle made of aluminium, with a double row of adjustable fins.
- Anti-vibration fitting for delivery/inlet duct connection.
- Intake/outlet plenum with round nozzles.

CONTROLS

STANDARD controls

For wall mounting installation

- Electronic panel with display and RS485 serial interface, semi-recessed in wall.

Advanced LIT-TOUCH controls

- Flush LIT-Touch control panel in glossy black or pearl white for wall mounting installation.
- Wall mounted LIT-Touch remote control and receiver with air temperature probe and operation LED.

For on board installation

- ❖ LIT-Touch electronic control for 2-pipe systems, with 2 pipes with electrical resistance or 4 pipes, complete with minimum water temperature probe, ON/OFF valve control and integrated master/slave function up to a total of 15 units.
- ❖ Additional board with 2 digital outputs that can be configured.
- ❖ On board air temperature probe.
- ❖ RS485 serial board for serial communication with other devices (Modbus RTU protocol).

- Key:
- ❖ Factory fitted
 - Supplied separately





YARDY-ID2 CXP			40	48	60	74	80	88
❶ Total cooling capacity [EN1397]	MAX	kW	3,01 E	3,28 E	4,12 E	4,58 E	5,88 E	6,26 E
	MED	kW	2,7 E	2,95 E	3,5 E	4,42 E	5,32 E	5,7 E
	MIN	kW	1,19 E	1,28 E	1,58 E	1,72 E	2,03 E	2,11 E
❷ Heating capacity (45°C) [EN1397]	MAX	kW	3,29 E	3,35 E	4,73 E	4,77 E	7,37 E	7,48 E
	MED	kW	2,93 E	2,97 E	4,53 E	4,48 E	6,6 E	6,71 E
	MIN	kW	1,16 E	1,18 E	1,58 E	1,6 E	2,5 E	2,51 E
❸ Heating capacity (50°C)	MAX	kW	3,86 E	3,94 E	5,52 E	5,63 E	8,55 E	8,72 E
	MED	kW	3,44 E	3,51 E	5,23 E	5,33 E	7,69 E	7,84 E
	MIN	kW	1,39 E	1,42 E	1,9 E	1,94 E	2,92 E	2,98 E
❹ Heating capacity (70°C) [EN1397]	MAX	kW	6,55	6,66	9,44	9,62	14,71	14,93
	MED	kW	5,84	5,92	9,04	9,1	13,21	13,42
	MIN	kW	2,35	2,39	3,24	3,27	5,1	5,13
❺ Heating capacity of additional coil (65°C) [EN1397]	MAX	kW	2,75 E	2,63 E	4,17 E	4,32 E	5,7 E	5,42 E
	MED	kW	2,51 E	2,41 E	4 E	3,7 E	5,1 E	5,02 E
	MIN	kW	1,28 E	1,22 E	1,91 E	1,91 E	2,42 E	2,3 E
❻ Heating capacity of additional coil (70°C) [EN1397]	MAX	kW	3,19 E	3,03 E	4,71 E	4,89 E	6,46 E	6,14 E
	MED	kW	2,92 E	2,78 E	4,51 E	4,18 E	5,78 E	5,69 E
	MIN	kW	1,48 E	1,41 E	2,21 E	2,2 E	2,79 E	2,65 E
Available static Air flow rate / Pressure	MAX	m³/h / Pa	469 / 64 E	469 / 64 E	737 / 56 E	737 / 56 E	1010 / 65 E	949 / 64 E
	MED	m³/h / Pa	410 / 50 E	410 / 50 E	691 / 50 E	691 / 50 E	866 / 50 E	831 / 50 E
	MIN	m³/h / Pa	150 / 8 E	150 / 8 E	214 / 6 E	214 / 6 E	284 / 7 E	254 / 7 E
❷ Delivery sound power	MAX	dB(A)	56 E	56 E	57 E	57 E	58 E	58 E
	MED	dB(A)	52 E	52 E	56 E	56 E	57 E	57 E
	MIN	dB(A)	30 E	30 E	30 E	30 E	30 E	30 E
❼ Delivery sound pressure	MAX	dB(A)	47	47	48	48	49	49
	MED	dB(A)	43	43	47	47	48	48
	MIN	dB(A)	21	21	21	21	21	21
Absorbed power	MAX	W	69 E	72 E	100 E	105 E	140 E	140 E
	MED	W	60 E	63 E	80 E	84 E	100 E	100 E
	MIN	W	8 E	8 E	8 E	8 E	13 E	13 E
Electrical supply	V-ph-Hz	230-1-50	230-1-50	230-1-50	230-1-50	230-1-50	230-1-50	
DIMENSIONS AND WEIGHTS			40	48	60	74	80	88
L - Width	mm	950	950	1250	1250	1250	1250	
H - Height	mm	545	545	545	545	545	545	
P - Depth	mm	212	212	212	212	212	212	
Weight	kg	25,5	26,5	34,5	35,5	36,5	37,5	
COVER for Yardy-ID2 CXP			40	48				
KCASE formwork	WxHxD	mm	1325x790x225	1325x790x225				
KCASE formwork	Weight	kg	17	17				
KPXCASE Panel	WxHxD	mm	1375x820x10	1375x820x10				
KPXCASE Panel	Weight	kg	11	11				
KGMD delivery nozzle	WxHxD	mm	955x205x6	955x205x6				

Data at the following conditions:

- ❶ Air: 27°C D.B.; 19°C W.B. - Water: 7/12°C.
- ❷ Air: 20°C - Water: 45/40°C.
- ❸ Air: 20°C - Water: 50°C, flow rate as in cooling.
- ❹ Air: 20°C - Water: 70/60°C.
- ❺ Air: 20°C - Water: 65/55°C.
- ❻ According to EN16583
- ❼ For room volume equal to 100 m³ and reverberation time = 0.5 sec.
- E Eurovent certified performance.

Performance refers to the motor's input signal: 10V - 7V - 2V at MAX - MED - MIN speed.

Yardy ID2 48 - 74 - 88 with oversized 4-row coil.

For the selection with Air'Suite filter, refer to the UP-TO-DATE selection Software.

YARDY-ID2 per installazione orizzontale e verticale

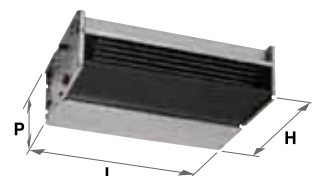

Ducted fan coils

YARDY-DUCT2

Cooling capacity: 1.9-5.7 kW - Heating capacity: 2.4-7.2 kW



TOUCH CONTROL



Panel LIT-Touch wall-mounted.

LIT-Touch remote control and wall mounting receiver.



air'suite

- Air'Suite biocide filter for healthier and cleaner air in indoor environments
- New touch controls
- Enhanced performance with 4-row coil
- 6-speed ductable version
- Horizontal and vertical installation
- Pre-fitted accessories and controls

Ducted fan coils for recessed horizontal or vertical installation.

Construction features

- Heat exchanger: with finned coil with left side connections reversible to the right.
- Centrifugal fan: 6 speeds connected to the terminal block.
- Structure: made of galvanised sheet steel complete with a natural condensate drain pan and regenerable filter.

Versions

- CXP - Recessed unit for horizontal or vertical installation (with lower return and upper delivery).

Construction set-ups

Type of unit

- 2T - Single main coil.
- 4T - Double main coil and additional.

ACCESSORIES

- Additional water heating coil for 4-pipe systems.
- Electrical resistance.
- 2-way ON/OFF electrovalves for 2 and 4-pipe systems.
- 3-way ON/OFF electrovalves for 2 and 4-pipe systems.
- 4-way ON/OFF electrovalves for 4-pipe systems with single main coil.
- Auxiliary condensate drain pan.
- Air'Suite biocide filter.
- ♦ Electrical box for connection terminal block.
- ♦ Air inlet flange: Ø10cm or Ø12cm.
- Flanged frame for connection to intake or delivery duct.
- Frame with Air'Suite biocide filter (G2) that can be extracted in any direction.
- Delivery straight fitting.
- 90° delivery and inlet fitting.
- Telescopic outlet/inlet fitting.
- Inlet grille with filter.
- Delivery grille.

- Formwork for recessed wall or false ceiling installation.
- Aesthetic panel for formwork, with air inlet grille for wall mounting or ceiling installation.
- Delivery nozzle made of aluminium, with a double row of adjustable fins.
- Anti-vibration fitting for delivery/inlet duct connection.
- Intake/outlet plenum with round nozzles.

CONTROLS

STANDARD controls

For wall mounting installation

- Panel with speed and summer/winter switch.
- Panel with room thermostat, summer/winter switch, speed switch, ON/OFF valve control and electrical resistance.
- Minimum temperature thermostat (for installation on machine).
- Electronic panel with automatic summer/winter switching for 2-pipe systems.
- Electronic panel with automatic summer/winter switching and automatic speed adjustment for 2-pipe systems with electrical resistance or 4-pipe systems.
- Interface board to control up to 4 fan coils (for on board installation).
- Electronic panel with display and RS485 serial interface, semi-recessed in wall.

Advanced LIT-TOUCH controls

- Flush LIT-Touch control panel in glossy black or pearl white for wall mounting installation.
- Wall mounted LIT-Touch remote control and receiver with air temperature probe and operation LED.

For on board installation

- LIT-Touch electronic control for 2-pipe systems, with 2 pipes with electrical resistance or 4 pipes, complete with a minimum water temperature probe, ON/OFF valve control and integrated master/slave function up to a total of 15 units.
- Additional board with 2 digital outputs that can be configured.
- On board air temperature probe.
- RS485 serial board for serial communication with other devices (Modbus RTU protocol).

- Key:
- ♦ Factory fitted
 - Supplied separately
 - * Previous name



YARDY-DUCT2 CXP		40	48	60	74	80	88
1 Total cooling capacity [EN1397]	VI	kW 1,9 E	2,22 E	3,47 E	4,43 E	4,83 E	5,69 E
	V	kW 1,76 E	2,06 E	3,33	4,26	4,61	5,53
	IV	kW 1,5	1,69	3,18 E	4 E	4,38 E	5,42 E
	III	kW 1,35 E	1,57 E	3,01	3,78	4,17	5,2
	II	kW 1,24	1,44	2,65 E	3,41 E	3,91 E	4,94 E
	I	kW 1,07	1,25	2,42	3,14	3,86	4,8
2 Heating capacity (45°C) [EN1397]	VI	kW 2,1 E	2,15 E	4,11 E	4,18 E	5,77 E	6,12 E
	V	kW 1,9 E	1,97 E	3,92	3,98	5,62	5,8
	IV	kW 1,53	1,59	3,69 E	3,75 E	5,51 E	5,74 E
	III	kW 1,4 E	1,46 E	3,49	3,54	5,3	5,45
	II	kW 1,27	1,33	3,21 E	3,26 E	4,78 E	5,1 E
	I	kW 1,11	1,16	2,94	2,98	4,61	5,06
3 Heating capacity (50°C)	VI	kW 2,44 E	2,53 E	4,74 E	4,98 E	6,68 E	7,16 E
	V	kW 2,21 E	2,32 E	4,52	4,75	6,51	6,84
	IV	kW 1,8	1,89	4,29 E	4,5 E	6,37 E	6,76 E
	III	kW 1,65 E	1,73 E	4,05	4,25	6,13	6,44
	II	kW 1,5	1,58	3,7 E	3,89 E	5,53 E	6,04 E
	I	kW 1,3	1,37	3,39	3,56	5,35	5,99
4 Heating capacity (70°C) [EN1397]	VI	kW 4,18	4,3	8,21	8,5	11,48	12,21
	V	kW 3,78	3,94	7,84	8,1	11,2	11,63
	IV	kW 3,07	3,2	7,44	7,67	10,98	11,52
	III	kW 2,82	2,93	7,04	7,24	10,56	10,98
	II	kW 2,56	2,67	6,48	6,65	9,52	10,32
	I	kW 2,22	2,31	5,95	6,08	9,2	10,26
5 Heating capacity of additional coil (65°C) [EN1397]	VI	kW 1,97 E	1,87 E	3,78 E	3,6 E	4,64 E	4,42 E
	V	kW 1,84 E	1,75 E	3,75	3,58	4,45	4,24
	IV	kW 1,7	1,61	3,62 E	3,42 E	4,36 E	4,15 E
	III	kW 1,5 E	1,43 E	3,52	3,36	4,25	4,05
	II	kW 1,41	1,34	3,42 E	3,22 E	4,16 E	3,95 E
	I	kW 1,27	1,21	3,32	3,15	4,04	3,85
4 Heating capacity of additional coil (70°C) [EN1397]	VI	kW 2,29 E	2,18 E	4,27 E	4,07 E	5,24 E	4,99 E
	V	kW 2,14 E	2,04 E	4,24	4,04	5,03	4,79
	IV	kW 1,97	1,87	4,09 E	3,9 E	4,93 E	4,69 E
	III	kW 1,75 E	1,66 E	3,99	3,8	4,81	4,58
	II	kW 1,63	1,55	3,88 E	3,7 E	4,7 E	4,47 E
	I	kW 1,47	1,4	3,8	3,61	4,57	4,35
Available static Air flow rate / Pressure	VI	m³/h 275 / 56 E	275 / 56 E	620 / 66 E	620 / 66 E	912 / 62 E	862 / 62 E
	V	m³/h 250 / 50 E	250 / 50 E	587 / 59	587 / 59	858 / 54	828 / 54
	IV	m³/h 198 / 33	198 / 33	539 / 50 E	539 / 50 E	820 / 50 E	800 / 50 E
	III	m³/h 180 / 19 E	180 / 28 E	504 / 44	504 / 44	772 / 45	759 / 45
	II	m³/h 163 / 16	163 / 24	445 / 34 E	445 / 34 E	715 / 39 E	708 / 39 E
	I	m³/h 140 / 9	140 / 18	402 / 28	402 / 28	685 / 35	680 / 35
6 Delivery sound power	VI	dB(A) 50 E	50 E	56 E	56 E	57 E	57 E
	V	dB(A) 48 E	48 E	55	55	55	55
	IV	dB(A) 43	43	54 E	54 E	54 E	54 E
	III	dB(A) 42 E	42 E	51	52	53	53
	II	dB(A) 38	38	50 E	50 E	51 E	51 E
	I	dB(A) 37	37	48	46	50	50
7 Delivery sound pressure	VI	dB(A) 41	41	47	47	48	48
	V	dB(A) 39	39	46	46	46	46
	IV	dB(A) 34	34	45	45	45	45
	III	dB(A) 33	33	42	43	44	44
	II	dB(A) 29	29	41	41	42	42
	I	dB(A) 28	28	39	37	41	41
Absorbed power	VI	W 68 E	71 E	128 E	135 E	154 E	154 E
	V	W 60 E	63 E	120	126	134	134
	IV	W 41	43	91 E	95 E	127 E	127 E
	III	W 36 E	38 E	88	93	109	109
	II	W 32	34	84 E	89 E	105 E	105 E
	I	W 27	28	77	80	91	91
Electrical supply	V-ph-Hz	230-1-50	230-1-50	230-1-50	230-1-50	230-1-50	230-1-50
DIMENSIONS AND WEIGHTS		40	48	60	74	80	88
L - Width	mm	950	950	1250	1250	1250	1250
H - Height	mm	545	545	545	545	545	545
P - Depth	mm	212	212	212	212	212	212
Weight	kg	25,5	27	34,5	35,5	36,5	37,5
COVER for Yardy - DUCT CXP		40	48				
KCASE formwork	WxHxD	mm 1325x790x225	1325x790x225				
KCASE formwork	Weight	kg 17	17				
KPXCASE Panel	WxHxD	mm 1375x820x10	1375x820x10				
KPXCASE Panel	Weight	kg 11	11				
KGMD delivery nozzle	WxHxD	mm 955x205x6	955x205x0,6				

Data at the following conditions:

- 1 Air: 27°C D.B.; 19°C W.B. - Water: 7/12°C.
 - 2 Air: 20°C - Water: 45/40°C.
 - 3 Air: 20°C - Water: 50°C, flow rate as in cooling.
 - 4 Air: 20°C - Water: 70/60°C.
 - 5 Air: 20°C - Water: 65/55°C.
 - 6 According to EN16583
 - 7 For room volume equal to 100 m³ and reverberation time = 0,5 sec.
- E Eurovent certified performance.
YARDY-DUCT2 48 - 74 - 88 with oversized 4-row coil.

For the selection with Air'Suite filter, refer to the UP-TO-DATE selection Software.

Web code: **YAHP1**Web code accessories: **ACMEC**Web code controls: **ACREG**

Ductable terminals

YARDY-HP

Cooling capacity: 7.0-19.8 kW - Heating capacity: 9.9-29.6 kW



KFG
Flange

KFC1 / KFC2 / KFC3
Frame with removable filter

KAS
Antivibration connection

KRDM
Intake straight connection

YARDY HP

PBAB
Plenum with coil additional coil or for post-heating

KRDM
Outlet straight connection

KBAM
Panel with circular nozzles

- Air'Suite biocide filter for healthier and cleaner air in indoor environments
- New touch controls
- Horizontal and vertical installation
- Pan removable from below for cleaning
- Hydraulic and electric connections on the same side.
- Set up with 3, 4, 5-row coil

Ductable terminals for recessed horizontal or vertical installation.

Construction features

- Structure: self-supporting, in galvanised sheet steel for horizontal installation in a false ceiling or vertical recessed wall installation, complete with a natural condensate drain pan, flanges to fit to the inlet/delivery duct. Pan is removable from below. Filter supplied separately from the unit.
- Finned coil heat exchanger, removable from below, with connections on the left, reversible to the right directly on site.
- Electrical connection box: on the left, on the same side as the hydraulic connections, reversible to the right directly on site.
- Double intake centrifugal fan with directly coupled 3-speed motor. Fan unit is removable from below.

Versions

- CXP - Recessed unit for horizontal or vertical installation (with lower return to upper delivery).

Number of rows

- 3 Rows - Unit with 3-row coil; for recessed horizontal/vertical installation.
- 4 Rows - Unit with 4-row coil; for recessed horizontal/vertical installation.
- 5 Rows - Unit with 5-row coil (only models 250, 300); for recessed horizontal/vertical installation.

Construction set-ups

Type of unit

- 2T - Single main coil
- 4T - Double main coil and additional

ACCESSORIES

- Additional water heating coil (1 row) for [4T-KBAA] 4-pipe systems - only for 3R units with a 3-row coil.
- External plenum with additional water heating coil for 4-pipe systems [PBAB].
- 2-way ON/OFF electrovalves for 2 and 4-pipe systems.

- 3-way ON/OFF electrovalves for 2 and 4-pipe systems.
- Auxiliary condensate drain pan.
- Frame with filter that can be extracted in any direction (G1 or G3).
- Frame with Air'Suite biocide filter (G2) that can be extracted in any direction.
- Straight delivery and inlet fitting.
- 90° delivery and inlet fitting.
- Flange for duct connection.
- Anti-vibration fitting for connection to the inlet/delivery duct.
- Panel with round nozzles to be connected to the delivery/inlet fittings.

CONTROLS

STANDARD controls

For wall mounting installation

- Panel with speed and summer/winter switch.
- Panel with room thermostat, summer/winter switch, speed switch, ON/OFF valve control and electrical resistance.
- Electronic panel with automatic summer/winter switching for 2-pipe systems.
- Electronic panel with automatic summer/winter switching and automatic speed adjustment for 2-pipe systems with electrical resistance or 4-pipe systems.
- Air probe with remote control option.
- Interface board to control up to 4 fan coils (models 100-150-200 only, for on board installation).

Advanced LIT-TOUCH controls

- Flush LIT-Touch control panel in glossy black or pearl white for wall mounting installation.
- Wall mounted LIT-Touch remote control and receiver with air temperature probe and operation LED.

For on board installation

- LIT-Touch electronic control for 2-pipe systems, with 2 pipes with electrical resistance or 4 pipes, complete with minimum water temperature probe, ON/OFF valve control and integrated master/slave function up to a total of 15 units.
- Additional board with 2 digital outputs that can be configured.
- On board air temperature probe.
- RS485 serial board for serial communication with other devices (Modbus RTU protocol).

- Key:
- ♦ Factory fitted
 - Supplied separately

TOUCH CONTROL



Panel LIT-Touch wall-mounted.

LIT-Touch remote control and wall mounting receiver.





YARDY HP CXP			100	150	200	250	300
❶ Total cooling capacity [EN1397]	3R MAX	kW	6,96	8,13	9,75	12,85	14,42
	3R MED	kW	6,45	6,49	7,19	9,32	11,15
	3R MIN	kW	5,33	6,19	6,43	6,87	9,82
❷ Heating capacity (45°C) [EN1397]	3R MAX	kW	8,38	10,23	12,58	17,03	19,51
	3R MED	kW	7,61	7,85	8,99	11,62	14,71
	3R MIN	kW	6,08	7,34	7,77	8,09	12,49
❸ Heating capacity (50°C)	3R MAX	kW	9,85	12,09	14,85	20,13	23,11
	3R MED	kW	9	9	10,41	13,64	17,01
	3R MIN	kW	7,27	8,53	9,11	9,64	14,6
❶ Total cooling capacity [EN1397]	4R MAX	kW	8,22	9,28	11,04	15,88	18
	4R MED	kW	7,53	8,09	8,95	11,79	14,31
	4R MIN	kW	6,31	7,61	8,14	8,36	12,52
❷ Heating capacity (45°C) [EN1397]	4R MAX	kW	9,32	10,93	13,34	19,59	22,62
	4R MED	kW	8,35	9,09	10,33	13,9	17,73
	4R MIN	kW	6,83	8,39	9,1	9,27	14,85
❸ Heating capacity (50°C)	4R MAX	kW	11,01	12,88	15,73	23,36	27,12
	4R MED	kW	9,93	10,58	12,11	16,55	20,9
	4R MIN	kW	8,18	9,87	10,79	11,15	17,67
❶ Total cooling capacity [EN1397]	5R MAX	kW	-	-	-	18,04	19,75
	5R MED	kW	-	-	-	12,78	16,32
	5R MIN	kW	-	-	-	8,91	14,04
❷ Heating capacity (45°C) [EN1397]	5R MAX	kW	-	-	-	21,83	24,62
	5R MED	kW	-	-	-	14,42	18,69
	5R MIN	kW	-	-	-	9,37	16,19
❸ Heating capacity (50°C)	5R MAX	kW	-	-	-	26,23	29,62
	5R MED	kW	-	-	-	17,26	22,23
	5R MIN	kW	-	-	-	11,47	19,24
❺ Heating capacity of additional coil (65°C) [EN1397]	4T -KBAA MAX	kW	6,11	6,23	8,63	9,88	10,76
❻ Heating capacity of additional coil (70°C) [EN1397]	4T -KBAA MAX	kW	6,89	7,03	9,73	11,12	12,11
❽ Heating capacity of additional coil (65°C) [EN1397]	PBAB MAX	kW	11,61	12,74	14,87	20,72	22,77
❹ Heating capacity of additional coil (70°C) [EN1397]	PBAB MAX	kW	13,1	14,39	16,78	23,36	25,67
❻ Air flow rate/Speed static pressure (3R)	MAX	m³/h / Pa	1.552 / 60	1.840 / 62	2.339 / 60	3.312 / 60	3.875 / 59
	MED	m³/h / Pa	1.370 / 50	1.620 / 50	1.717 / 50	2.189 / 50	3.075 / 50
	MIN	m³/h / Pa	1.013 / 35	1.432 / 35	1.414 / 35	1.329 / 35	2.415 / 35
❼ Delivery sound power (3R)	MAX	dB(A)	61	62	62	63	68
	MED	dB(A)	59	61	60	59	64
	MIN	dB(A)	56	59	57	55	61
❽ Speed sound pressure (3R)	MAX	dB(A)	47	48	48	49	54
	MED	dB(A)	45	47	46	45	50
	MIN	dB(A)	42	45	43	41	47
Nominal spd absorbed power MAX	3R	W	200	245	380	680	800
	4R	W	190	230	330	670	750
	5R	W	-	-	-	660	750
Maximum absorbed power (0 Pa)	3R	W	280	300	500	850	900
Electrical supply		V-ph-Hz	230-1-50	230-1-50	230-1-50	230-1-50	230-1-50
DIMENSIONS AND WEIGHTS			100	150	200	250	300
L - Width		mm	1295	1295	1295	1295	1295
H - Height		mm	250	250	285	335	335
P - YARDY HP Depth		mm	555	555	670	720	720
P - PBAB Depth		mm	200	200	200	200	200
YARDY HP Weight		kg	38	38	46	57	57

Data at the following conditions:

- ❶ Air: 27°C D.B.; 19°C W.B. - Water: 7/12°C.
- ❷ Air: 20°C - Water: 45/40°C.
- ❸ Air: 20°C - Water: 50°C, flow rate as in cooling.
- ❹ Air: 20°C - Water: 70/60°C.
- ❺ Air: 20°C - Water: 65/55°C.
- ❻ 3-row coil (3R) without filter.
- ❼ With G3 filter at the conditions specified in point 6 according to EN16583
- ❽ At 2 m from the air outflow point with directionality factor 2 and G3 filter.

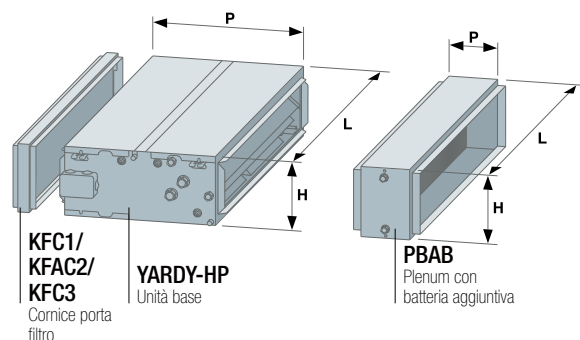

Cassette fan coils with EC motor

DIVA-I

Cooling capacity: 2.7-10.7 kW - Heating capacity: 3.4-12.7 kW

INVERTER

- Consumption reduced by 50% with EC motor
- Set-ups for 2 or 4-pipe installations or 2 pipe installations with electrical resistance
- ABS or metal ceiling panelling with Coanda effect
- New touch controls
- 2 or 3-way, ON/OFF electrovalves and pre-mounted controls on board

Cassette-type fan coil units.

Construction features

- Fan coils: cassette-type for installation in false ceilings, with air return and delivery directly in the room.
- Heat exchanger: finned coil.
- Radial fan;
- Inverter brushless EC motor.
- Structure: self-supporting, in galvanised sheet steel complete with an additional condensate drain pan and pump to lift the condensate (maximum head 650 mm).
- PLP buffer ceiling (accessory supplied separately): in ABS polymer (RAL 9003) with manually adjustable delivery fins, return grille and regenerable filter.

Construction set-ups

Type of unit

2T - Single main coil

4T - Double main coil and additional

RE - Single main coil and supplementary electrical resistance.

ACCESSORIES

- PLP - ABS ceiling panelling (RAL 9003).
- PLM - Metal ceiling panelling (RAL 9003) flush with false ceiling with Coanda effect.
- 3-way ON/OFF electrovalve for 2 and 4-pipe systems.
- 2-way ON/OFF electrovalves for 2 and 4-pipe systems.
- Primary air duct fitting.
- Circular connector for air distribution at a distance

from the unit.

- Primary air kit.

CONTROLS

STANDARD controls

For wall mounting installation

- Electronic panel with display and RS485 serial interface, semi-recessed in wall.

Advanced LIT-TOUCH controls

- Flush LIT-Touch control panel in glossy black or pearl white for wall mounting installation.

- LIT-Touch remote control and receiver for ceiling panelling or wall mounting installation, with air temperature probe and operation LED.

For on board installation

- LIT-Touch electronic control for 2-pipe systems, with 2 pipes with electrical resistance or 4 pipes, complete with minimum water temperature probe, ON/OFF valve control and integrated master/slave function up to a total of 15 units.
- Additional board with 2 digital outputs that can be configured.
- On board air temperature probe.
- RS485 serial board for serial communication with other devices (Modbus RTU protocol).

- Key: ♦ Factory fitted
 → Supplied separately



TOUCH CONTROL



Panel LIT-Touch wall-mounted.



LIT-Touch remote control and on board or wall mounting receiver.



PLM - Metal ceiling panelling with Coanda effect.



DIVA-I 2T - DIVA-I RE			30	40	50	60	110
❶ Total cooling capacity [EN1397]	MAX	kW E	2,73	4,3	4,96	6,3	10,69
	MED	kW E	2,16	3,04	3,85	5,13	7,69
	MIN	kW E	1,84	2,24	2,55	4,2	5,28
❷ Heating capacity (45°C) [EN1397]	MAX	kW E	2,87	4,36	5,15	6,7	10,56
	MED	kW E	2,22	2,98	3,85	5,3	7,34
	MIN	kW E	1,86	2,13	2,46	4,27	4,9
❸ Heating capacity (50°C)	MAX	kW E	3,44	5,24	6,2	8,01	12,7
	MED	kW E	2,67	3,58	4,63	6,35	8,83
	MIN	kW E	2,22	2,55	2,96	5,11	5,89
❹ Heating capacity (70°C) [EN1397]	MAX	kW	5,81	8,81	10,47	13,5	21,34
	MED	kW	4,5	5,99	7,77	10,68	14,75
	MIN	kW	3,75	4,29	4,96	8,57	9,81
RE electrical resistance	230-1-50 V	kW	-	1,5	2,5	2,5	3
Air flow speed	MAX	m³/h	535	710	880	1165	1770
	MED	m³/h	380	445	610	870	1130
	MIN	m³/h	310	310	360	630	710
Sound power	MAX	dB(A) E	47	54	60	48	57
	MED	dB(A) E	39	43	50	39	47
	MIN	dB(A) E	33	33	37	33	34
❻ Sp. sound pressure	MAX	dB(A)	38	45	51	39	48
	MED	dB(A)	30	34	41	30	38
	MIN	dB(A)	24	24	28	24	25
Absorbed power	MAX	W E	16	31	62	33	108
	MED	W E	8	11	21	17	32
	MIN	W E	5	5	7	10	10
Electrical supply	V-ph-Hz		230-1-50	230-1-50	230-1-50	230-1-50	230-1-50
DIMENSIONS AND WEIGHT			30	40	50	60	110
Box - Dimensions WxHxD	mm		575 x 275 x 575	575 x 275 x 575	575 x 275 x 575	820 x 303 x 820	820 x 303 x 820
PLP Ceiling panelling - Dimensions WxHxD	mm		670x 67x 670	670x 67x 670	670x 67x 670	965 x 85 x 965	965 x 85 x 965
Box - Weight	kg		22	24	24	36	39
PLP Ceiling panelling - Weight	kg		3	3	3	6	6

DIVA-I 4T			30	40	50	60	110
❶ Total cooling capacity [EN1397]	MAX	kW E	2,75	3,9	4,47	6,48	9,76
	MED	kW E	2,17	2,8	3,51	5,26	7,14
	MIN	kW E	1,85	2,09	2,37	4,29	4,97
❷ Heating capacity of additional coil (65°C) [EN1397]	MAX	kW E	3,18	2,91	3,29	8,24	8,33
	MED	kW E	2,51	2,2	2,66	6,65	6,27
	MIN	kW E	2,14	1,74	1,92	5,41	4,58
❹ Heating capacity of additional coil (70°C) [EN1397]	MAX	kW E	3,64	3,38	3,85	9,39	9,62
	MED	kW E	2,86	2,54	3,08	7,56	7,19
	MIN	kW E	2,44	1,99	2,21	6,15	5,23
Air flow speed	MAX	m³/h	535	710	880	1165	1770
	MED	m³/h	380	445	610	870	1130
	MIN	m³/h	310	310	360	630	710
Sound power	MAX	dB(A) E	47	54	60	48	57
	MED	dB(A) E	39	43	50	39	47
	MIN	dB(A) E	33	33	37	33	34
❻ Sp. sound pressure	MAX	dB(A)	38	45	51	39	48
	MED	dB(A)	30	34	41	30	38
	MIN	dB(A)	24	24	28	24	25
Absorbed power	MAX	W E	16	31	62	33	108
	MED	W E	8	11	21	17	32
	MIN	W E	5	5	7	10	10
Electrical supply	V-ph-Hz		230-1-50	230-1-50	230-1-50	230-1-50	230-1-50
DIMENSIONS AND WEIGHT			30	40	50	60	110
Box - Dimensions WxHxD	mm		575 x 275 x 575	575 x 275 x 575	575 x 275 x 575	820 x 303 x 820	820 x 303 x 820
PLP Ceiling panelling - Dimensions WxHxD	mm		670x 67x 670	670x 67x 670	670x 67x 670	965 x 85 x 965	965 x 85 x 965
Box - Weight	kg		22	24	24	36	39
PLP Ceiling panelling - Weight	kg		3	3	3	6	6

Data at the following conditions:

- ❶ Air: 27°C D.B.; 19°C W.B. - Water: 7/12°C.
 - ❷ Air: 20°C - Water: 45/40°C.
 - ❸ Air: 20°C - Water: 50°C, flow rate as in cooling.
 - ❹ Air: 20°C - Water: 70/60°C.
 - ❺ Air: 20°C - Water: 65/55°C.
 - ❻ For room volume equal to 100 m³ and reverberation time = 0.5 sec.
- E Eurovent certified performance.
 Performance refers to the motor's input signal: 10V - 5V - 1V at MAX - MED - MIN speed.

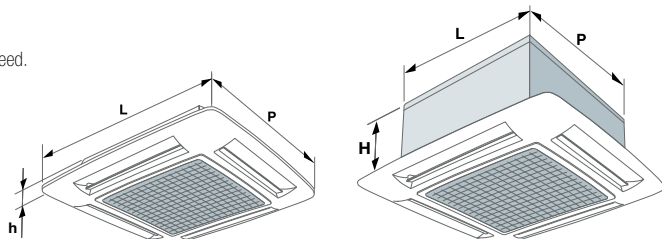

Cassette fan coils with EC motor

DIVA-XLI DIVA-XLI SWING

Cooling capacity: 12.6-15.1 kW - Heating capacity: 13.4-16.4 kW

INVERTER



new

TOUCH CONTROL



Wall-mounted LIT-Touch panel



- Innovative design for large environments
- ABS ceiling panelling with manual or motorised fins and filter option ePM1-55%
- Consumption reduced with EC motor
- Touch controls
- Set-ups for 2-, 4-pipe installations or 2 pipes with electrical resistance
- 2 or 3-way, ON/OFF electrovalves and pre-mounted controls on board

Cassette-type fan coil units

Construction features

- Fan coils: cassette-type for installation in false ceilings, with air return and delivery directly in the room, composed of a buffer ceiling unit.

DIVA-XLI

- Unit complete with:
 - Heat exchanger: finned coil.
 - Radial fan;
 - Inverter brushless EC motor.
 - Structure: self-supporting, in galvanised sheet steel complete with an additional condensate drain pan and pump to lift the condensate (maximum head 650 mm).
- Buffer ceiling (PLP or PLP/PM1 accessory): in ABS polymer (RAL 9003) with manually adjustable delivery fins and return grille.

DIVA-XLI SWING

- Unit complete with:
 - Heat exchanger: finned coil.
 - Radial fan;
 - Inverter brushless EC motor.
 - Structure: self-supporting, in galvanised sheet steel complete with an additional condensate drain pan and pump to lift the condensate (maximum head 650 mm).
 - SWING advanced control for motorised fins integrated in the unit.
- Buffer ceiling (PLP/S or PLP/S/PM1 accessory): in ABS polymer (RAL 9003) with return grille, filter, IR receiver and motorised delivery fins.

Construction set-ups

Type of unit

- 2T - Single main coil
- 4T - Double main coil and additional
- RE - Single main coil and supplementary electrical resistance.

ACCESSORIES

DIVA-XLI

- PLP- ABS Ceiling panelling (RAL 9003), with regenerable filter (GO).
- PLP/PM1 - ABS Ceiling panelling (RAL 9003), with filter ePM1-55% (F7).

DIVA-XLI SWING

- PLP/S- ABS Ceiling panelling (RAL 9003), with motorised fins and regenerable filter (GO).

- PLP/S/PM1 - ABS Ceiling panelling (RAL 9003), with motorised fins and filter ePM1-55% (F7).
- DIVA-XLI; DIVA-XLI SWING
- 3-way ON/OFF electrovalve for 2 and 4-pipe systems.
- 2-way ON/OFF electrovalves for 2 and 4-pipe systems.
- Circular connector for air distribution at a distance from the unit.
- Primary air kit.
- Casing for in view installation.
- 3-way ON/OFF electrovalve for in view casing.

CONTROLS

DIVA-XLI

STANDARD control for DIVA_XLI

For wall mounting installation

- Electronic panel with display and RS485 serial interface, semi-recessed in wall.

Advanced LIT-TOUCH controls

- Flush LIT-Touch control panel in glossy black or pearl white for wall mounting installation.
- LIT-Touch remote control and receiver for ceiling panelling or wall mounting installation, with air temperature probe and operation LED.

For on board installation

- LIT-Touch electronic control for 2-pipe systems, with 2 pipes with electrical resistance or 4 pipes, complete with minimum water temperature probe, ON/OFF valve control and integrated master/slave function up to a total of 15 units.
- Additional board with 2 digital outputs that can be configured.
- On board air temperature probe.
- RS485 serial board for serial communication with other devices (Modbus RTU protocol).

DIVA-XLI SWING

SWING advanced control for motorised fins integrated in the unit.

- Control panel flush with the display.
- Remote control.
- Wall mounting receiver with probe and LED.

- Key: ♦ Factory fitted
 → Supplied separately

DIVA-XLI - DIVA-XLI SWING	2T - RE		130	150
❶ Total cooling capacity [EN1397]	MAX	kW E	12,6	15,13
	MED	kW E	9,43	11,38
	MIN	kW E	6,36	7,86
❷ Heating capacity (45°C) [EN1397]	MAX	kW E	13,39	16,4
	MED	kW E	9,59	11,86
	MIN	kW E	6,18	7,82
❸ Heating capacity (50°C)	MAX	kW E	15,84	19,57
	MED	kW E	11,42	14,07
	MIN	kW E	7,39	9,33
❹ Heating capacity (70°C) [EN1397]	MAX	kW	26,63	33,06
	MED	kW	19,1	23,61
	MIN	kW	12,33	15,6
RE electrical resistance	230-1-50 V, 400-3-50 V	kW	3	3
Air flow speed	MAX	m³/h	1905	2480
	MED	m³/h	1290	1650
	MIN	m³/h	790	1025
Sound power	MAX	dB(A) E	58	64
	MED	dB(A) E	49	55
	MIN	dB(A) E	38	44
❻ Sp. sound pressure	MAX	dB(A)	49	55
	MED	dB(A)	40	46
	MIN	dB(A)	29	35
Absorbed power	MAX	W E	93	183
	MED	W E	35	64
	MIN	W E	13	21
Electrical supply	V-ph-Hz		230-1-50	230-1-50
DIMENSIONS AND WEIGHT			130	150
Box - Dimensions WxHxD	mm		869 x 304 x 869	869 x 304 x 869
PLP Ceiling panelling - Dimensions WxHxD	mm		1017 x 67 x 1017	1017 x 67 x 1017
Box - Weight	kg		42	42
PLP Ceiling panelling - Weight	kg		7,5	7,5

DIVA-XLI - DIVA-XLI SWING	4T		130	150
❶ Total cooling capacity [EN1397]	MAX	kW E	11,61	13,59
	MED	kW E	8,86	10,59
	MIN	kW E	6,07	7,45
❺ Heating capacity of additional coil (65°C) [EN1397]	MAX	kW E	10,55	12,17
	MED	kW E	8,40	9,80
	MIN	kW E	6,01	7,19
❻ Heating capacity of additional coil (70°C) [EN1397]	MAX	kW	12,04	13,89
	MED	kW	9,58	11,18
	MIN	kW	6,84	8,20
Air flow speed	MAX	m³/h	1905	2480
	MED	m³/h	1290	1650
	MIN	m³/h	790	1025
Sound power	MAX	dB(A) E	58	64
	MED	dB(A) E	49	55
	MIN	dB(A) E	38	44
❻ Sp. sound pressure	MAX	dB(A)	49	55
	MED	dB(A)	40	46
	MIN	dB(A)	29	35
Absorbed power	MAX	W E	93	183
	MED	W E	35	64
	MIN	W E	13	21
Electrical supply	V-ph-Hz		230-1-50	230-1-50
DIMENSIONS AND WEIGHT			130	150
Box - Dimensions WxHxD	mm		869 x 304 x 869	869 x 304 x 869
PLP Ceiling panelling - Dimensions WxHxD	mm		1017 x 67 x 1017	1017 x 67 x 1017
Box - Weight	kg		42	42
PLP Ceiling panelling - Weight	kg		7,5	7,5

Data at the following conditions:

- ❶ Air: 27°C D.B.; 19°C W.B. - Water: 7/12°C.
- ❷ Air: 20°C - Water: 45/40°C.
- ❸ Air: 20°C - Water: 50°C, flow rate as in cooling.
- ❹ Air: 20°C - Water: 70/60°C.
- ❺ Air: 20°C - Water: 65/55°C.
- ❻ For room volume equal to 100 m³ and reverberation time = 0.5 sec.

E Eurovent certified performance.

Performance refers to the motor's input signal: 10V - 5V - 1V at MAX - MED - MIN speed.

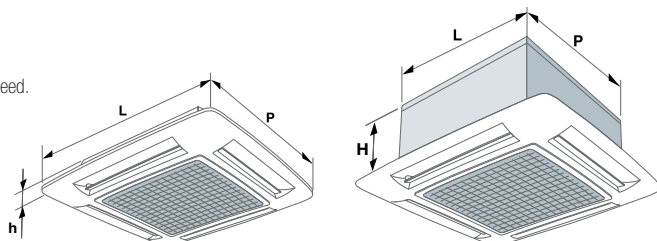

Cassette fan coils

DIVA

Cooling capacity: 1.9-10.9 kW - Heating capacity: 2.6-14.0 kW



TOUCH CONTROL



Panel
LIT-Touch
wall-mounted.



Remote control
LIT-Touch and
on board or
wall mounting
receiver.



- Set-ups for 2 or 4-pipe installations or 2 pipe installations with electrical resistance
- ABS or metal ceiling panelling with Coanda effect.
- New touch controls
- 2 or 3-way, ON/OFF electrovalves and pre-mounted controls on board

Cassette-type fan coil units.

Construction features

- Fan coils: cassette-type for installation in false ceilings, with air return and delivery directly in the room.
- Heat exchanger: finned coil.
- Radial fan.
- 6-speed motor, 3 of which are connected in a terminal block.
- Structure: self-supporting, in galvanised sheet steel complete with an additional condensate drain pan and pump to lift the condensate (maximum head 650 mm).
- PLP buffer ceiling (accessory): in ABS polymer (RAL 9003) with manually adjustable delivery fins, return grille and regenerable filter.

Construction set-ups

Type of unit

- 2T - Single main coil
- 4T - Double main coil and additional
- RE - Single main coil and supplementary electrical resistance.

ACCESSORIES

- PLP-ABS ceiling panelling (RAL 9003).
- PLM - Metal ceiling panelling (RAL 9003) flush with false ceiling with Coanda effect.
- 3-way ON/OFF electrovalve for 2 and 4-pipe systems.
- 2-way ON/OFF electrovalves for 2 and 4-pipe systems.
- Primary air duct fitting.
- Circular connector for air distribution at a distance from the unit.
- Primary air kit.

CONTROLS

STANDARD controls

For wall mounting installation

- Panel with speed and summer/winter switch.
- Panel with room thermostat, summer/winter switch, speed switch, ON/OFF valve control and electrical resistance.
- Electronic panel with automatic summer/winter switching for 2-pipe systems.
- Electronic panel with automatic summer/winter switching and automatic speed adjustment for 2-pipe systems with electrical resistance or 4-pipe systems.
- Electronic panel with display and RS485 serial interface, semi-recessed in wall.
- Interface board to control up to 4 fan coils.

Advanced LIT-TOUCH controls

- Flush LIT-Touch control panel in glossy black or pearl white for wall mounting installation.
- LIT-Touch remote control and receiver for ceiling panelling or wall mounting installation, with air temperature probe and operation LED.

For on board installation

- LIT-Touch electronic control for 2-pipe systems, with 2 pipes with electrical resistance or 4 pipes, complete with minimum water temperature probe, ON/OFF valve control and integrated master/slave function up to a total of 15 units.
- Additional board with 2 digital outputs that can be configured.
- On board air temperature probe.
- RS485 serial board for serial communication with other devices (Modbus RTU protocol).

- Key: ♦ Factory fitted
 → Supplied separately



PLM - Metal ceiling panelling with Coanda effect.

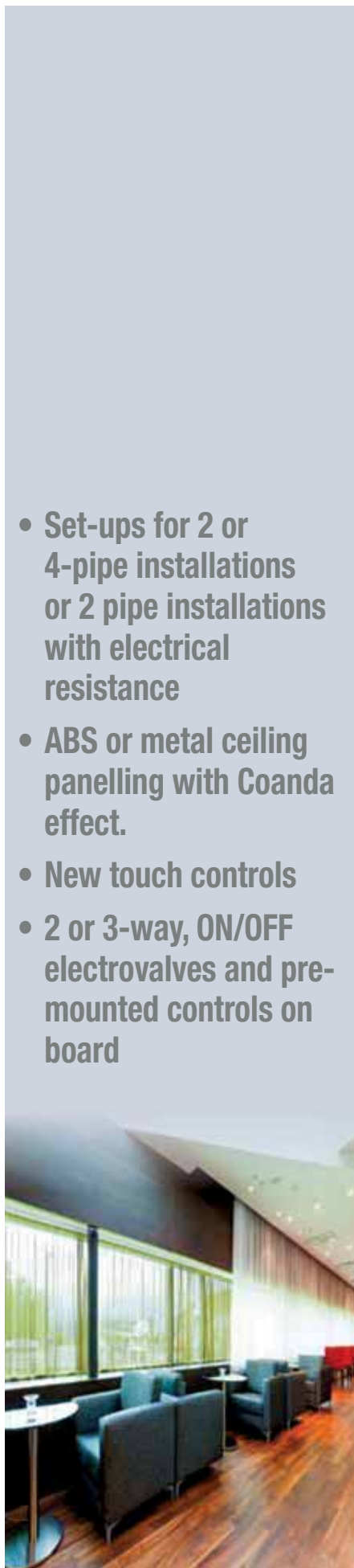

DIVA 2T - DIVA RE			20	30	40	50	60	90	110	
❶ Total cooling capacity [EN1397]	MAX	kW E	1,92	2,64	4,26	4,93	6,08	9,39	10,93	
	MED	kW E	1,6	2,31	3,3	3,82	4,86	6,72	8,36	
	MIN	kW E	1,25	1,82	2,23	2,91	4,18	5,27	5,27	
❷ Heating capacity (45°C) [EN1397]	MAX	kW E	2,24	2,8	4,37	5,15	6,5	9,23	11,77	
	MED	kW E	1,8	2,42	3,28	3,85	5,03	6,4	8,56	
	MIN	kW E	1,39	1,86	2,13	2,85	4,27	4,92	5,12	
❸ Heating capacity (50°C)	MAX	kW E	2,64	3,35	5,23	6,17	7,77	10,7	14	
	MED	kW E	2,12	2,9	3,93	4,63	6,03	7,34	10,3	
	MIN	kW E	1,62	2,22	2,56	3,43	5,12	5,61	6,13	
❹ Heating capacity (70°C) [EN1397]	MAX	kW	4,13	5,32	8,58	10,29	12,08	15,55	22,63	
	MED	kW	2,8	4,37	6,32	7,69	9,29	9,98	17,21	
	MIN	kW	2,03	3,24	4,13	5,48	7,19	7,23	9,74	
RE electrical resistance	230-1-50 V	kW	-	1,5	2,5	2,5	3	3	3	
Air flow speed	MAX	m³/h	610	520	710	880	1140	1500	1820	
	MED	m³/h	420	420	500	610	820	970	1280	
	MIN	m³/h	310	310	320	430	630	710	710	
Sound power	MAX	dB(A) E	49	45	53	59	48	53	58	
	MED	dB(A) E	40	40	45	49	40	40	48	
	MIN	dB(A) E	33	33	33	41	33	34	34	
❻ Sp. sound pressure	MAX	dB(A)	40	36	44	50	39	44	49	
	MED	dB(A)	31	31	36	40	31	31	39	
	MIN	dB(A)	24	24	24	32	24	25	25	
Absorbed power	MAX	W E	57	44	68	90	77	120	170	
	MED	W E	32	32	44	57	48	63	95	
	MIN	W E	25	25	25	32	33	42	42	
Electrical supply	V-ph-Hz	230-1-50	230-1-50	230-1-50	230-1-50	230-1-50	230-1-50	230-1-50	230-1-50	
DIMENSIONS AND WEIGHT			20	30	40	50	60	90	110	
Box - Dimensions WxHxD	mm	575 x 275 x 575					820 x 303 x 820			
PLP Ceiling panelling - Dimensions WxHxD	mm	670x 67x 670					965 x 85 x 965			
Box - Weight	kg	22	22	24	24	36	39	39	39	
PLP Ceiling panelling - Weight	kg	3	3	3	3	6	6	6	6	

DIVA 4T			20	30	32	40	42	50	60	80	90	92	110
❶ Total cooling capacity [EN1397]	MAX	kW E	2,27	2,66	3,27	3,86	3,72	4,44	6,26	7,59	8,65	8,72	10,03
	MED	kW E	1,93	2,33	2,61	3,02	2,96	3,47	4,98	5,6	6,27	6,84	7,75
	MIN	kW E	1,49	1,83	1,83	2,07	2,33	2,69	4,11	4,48	4,95	4,48	4,95
❷ Heating capacity of additional coil (65°C) [EN1397]	MAX	kW E	2,66	3,04	3,86	2,91	4,19	3,29	8,02	9,66	7,5	11,16	8,58
	MED	kW E	2,23	2,66	3,04	2,4	3,33	2,66	6,33	7,15	5,63	8,81	6,79
	MIN	kW E	1,73	2,14	2,14	1,74	2,61	2,14	5,21	5,69	4,59	5,69	4,59
❸ Heating capacity of additional coil (70°C) [EN1397]	MAX	kW E	3,09	3,5	4,47	3,42	5,04	3,88	9,18	11,12	8,68	12,87	9,97
	MED	kW E	2,57	3,05	3,5	2,75	4,03	3,12	7,24	8,16	6,48	10,08	7,5
	MIN	kW E	1,99	2,46	2,46	2,01	3,13	2,49	5,94	6,49	5,27	6,49	5,27
Air flow speed	MAX	m³/h	610	520	710	710	880	880	1140	1500	1500	1820	1820
	MED	m³/h	420	420	500	500	610	610	820	970	970	1280	1280
	MIN	m³/h	310	310	320	320	430	430	630	710	710	710	710
Sound power	MAX	dB(A) E	49	45	53	53	59	59	48	53	53	58	58
	MED	dB(A) E	40	40	45	45	49	49	40	40	40	48	48
	MIN	dB(A) E	33	33	33	33	41	41	33	34	34	34	34
❹ Sp. sound pressure	MAX	dB(A)	40	36	44	44	50	50	39	44	44	49	49
	MED	dB(A)	31	31	36	36	40	40	31	31	31	39	39
	MIN	dB(A)	24	24	24	24	32	32	24	25	25	25	25
Absorbed power	MAX	W E	57	44	68	68	90	90	77	120	120	170	170
	MED	W E	32	32	44	44	57	57	48	63	63	95	95
	MIN	W E	25	25	25	25	32	32	33	42	42	42	42
Electrical supply	V-ph-Hz	230-1-50	230-1-50	230-1-50	230-1-50	230-1-50	230-1-50	230-1-50	230-1-50	230-1-50	230-1-50	230-1-50	230-1-50
DIMENSIONS AND WEIGHT			20	30	32	40	42	50	60	80	90	92	110
Box - Dimensions WxHxD	mm	575 x 275 x 575					820 x 303 x 820						
PLP Ceiling panelling - Dimensions WxHxD	mm	670x 67x 670					965 x 85 x 965						
Box - Weight	kg	24	24	24	24	24	24	39	39	39	39	39	39
PLP Ceiling panelling - Weight	kg	3	3	3	3	3	3	6	6	6	6	6	6

Data at the following conditions:

- ❶ Air: 27°C D.B.; 19°C W.B. - Water: 7/12°C.
 - ❷ Air: 20°C - Water: 45/40°C.
 - ❸ Air: 20°C - Water: 50°C, flow rate as in cooling.
 - ❹ Air: 20°C - Water: 70/60°C.
 - ❺ Air: 20°C - Water: 65/55°C.
 - ❻ For room volume equal to 100 m³ and reverberation time = 0.5 sec.
- E Eurovent certified performance.

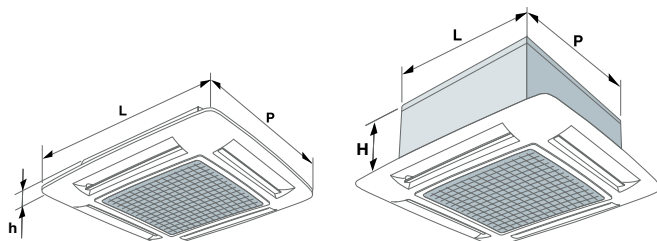

Wall mounted fan coils with EC motor

IDROWALL-I

Cooling capacity: 2.0-3.5 kW - Heating capacity: 3.0-5.1 kW

INVERTER



- Consumption reduced by 50% compared to the traditional motor
- 3-way valve on board
- Integrated master/slave function and serial interface
- Remote control included

Wall mounted fan coils.

Construction features

- Heat exchanger: finned coil.
- Fan: tangential with Inverter Brushless EC motor with continuous speed adjustment.
- Baffle: motorised with different positions.
- Structure: made of heat-resistant ABS polymer, RAL 9003 colour, complete with a regenerable polypropylene filter, adjustable fins and a natural condensate drain pan.
- Unit equipped with a 3-way ON/OFF valve and resident RS485 serial interface.
- Control: microprocessor electronic control.
Adjustment functions: full auto, cool, dry, fan, autofan, heat. Comfort functions: orienting, swing, timer, sleep, hot start, memory.
Remote control supplied as standard.

Separately supplied accessories

- KV2V - 2-way ON/OFF valve accessory. Assembled on board by the installer.
- K2TF - Accessory for electrovalve use externally to the unit. Assembled by the installer.
- KVAM - Wall mounted recessed box.

Controls supplied separately

- KWPI - Electronic panel for wall mounting installation.
- KWPCI - Centralised electronic panel for wall mounting installation Power supply V230-1-50.



KWPCI centralised panel

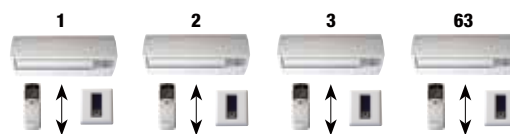

CENTRALISED MANAGEMENT OF UP TO 63 UNITS DISTANCE UP TO 1200 m

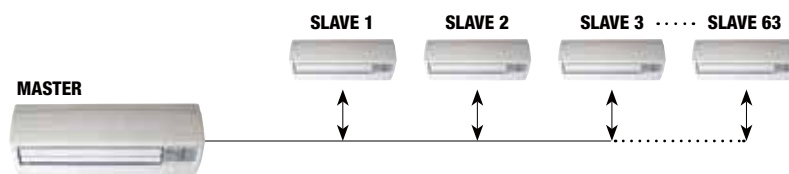

MASTER/SLAVE MANAGEMENT OF UP TO 64 UNITS FOR A TOTAL DISTANCE OF 1200 m



Remote control
•
Flush panel KWPI



IDROWALL-I			21	31	41
❶ Total cooling capacity [EN1397]	MAX	kW E	1,99	2,95	3,5
	MED	kW E	1,63	2,14	2,45
	MIN	kW E	1,32	1,89	1,89
❷ Heating capacity (45°C) [EN1397]	MAX	kW E	2,68	4,2	4,45
	MED	kW E	2,02	3,04	3,63
	MIN	kW E	1,45	2,61	2,61
❸ Heating capacity (50°C)	MAX	kW E	3,05	4,78	5,14
	MED	kW E	2,34	3,46	4,11
	MIN	kW E	1,72	2,98	2,98
❹ Heating capacity (70°C) [EN1397]	MAX	kW	5,53	8,49	9
	MED	kW	4,2	6,23	7,37
	MIN	kW	3,02	5,36	5,36
Air flow speed	MAX	m³/h	556	722	814
	MED	m³/h	413	473	581
	MIN	m³/h	295	396	396
❺ Sound power	MAX	dB(A) E	52	55	59
	MED	dB(A) E	43	46	51
	MIN	dB(A) E	34	42	42
Sound pressure	MAX	dB(A)	43	46	50
	MED	dB(A)	34	37	42
	MIN	dB(A)	25	33	33
Absorbed power	MAX	W E	22	27	38
	MED	W E	14	15	19
	MIN	W E	11	12	12
Electrical supply	V-ph-Hz	230-1-50	230-1-50	230-1-50	
DIMENSIONS AND WEIGHTS			21	31	41
L - Width	mm	795	990	990	
H - Height	mm	290	290	290	
P - Depth	mm	230	230	230	
Weight	kg	9,3	11,6	11,6	

Data at the following conditions:

- ❶ Air: 27°C D.B.; 19°C W.B. - Water: 7/12°C.
 - ❷ Air: 20°C - Water: 45/40°C.
 - ❸ Air: 20°C - Water: 50°C, flow rate as in cooling.
 - ❹ Air: 20°C - Water: 70/60°C.
 - ❺ For room volume equal to 100 m³ and reverberation time = 0.5 sec.
- E Eurovent certificate performance.



Remote control
 ●
 Centralised panel
 ●
 Flush panel

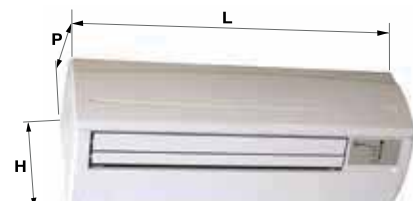



CONTROLS
for fan coil units

Electronic controls
for Brio-I Slim fan coils

SLIM-Touch Controls

Ideal climate with a simple touch

The electronic control with touch interface can provide the right conditions at any time of the day, particularly during the night as there is a super-minimum speed to guarantee the appropriate level of acoustic comfort for sleep.

The elegant and slim touch interface is available for wall mounting installation or on-board unit mounting.

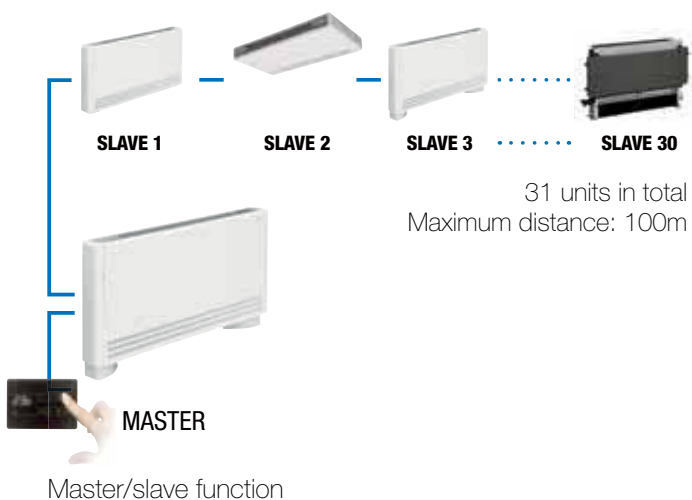



CONTROLS for fan coil units



ADVANCED SLIM-TOUCH CONTROLS

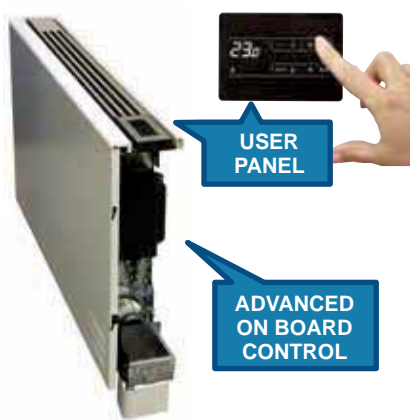

RANGE	BRIO-I SLIM			
	ON BOARD CONTROL	ON BOARD CONTROL	WALL MOUNTED PANEL	/
USER PANEL				
TYPE	B	B	KPSTB o KPSTW	/
				No user panel
	4 speeds	4 speeds + continuous modulation	4 speeds + continuous modulation	4 speeds + continuous modulation
Master/Slave Function	/	/	MASTER	SLAVE

ADDITIONAL COMPONENTS ON BOARD CONTROL		Supply		↓	↓	↓	↓
SLIM-TOUCH CONTROL	Electronic control for 2-pipe systems	Factory fitted		CS.F/B	CS.M/B	CS.M/P + KPSTB / KPSTW	CS.M/P
		Supplied separately		KCS.F/B	KCS.M/B	KCS.M/P + KPSTB / KPSTW	KCS.M/P
	Electronic control for 4-pipe systems	Factory fitted		/	CS.M/B	CS.M/P + KPSTB / KPSTW	CS.M/P
		Supplied separately		/	KCS.M/B	KCS.M/P + KPSTB / KPSTW	KCS.M/P
ADDITIONAL COMPONENTS	Air temperature probe installed on the unit	Factory fitted		AS STANDARD		/	
	RS485 Modbus RTU serial board	Factory fitted		/	AS STANDARD	AS STANDARD	/

Air temperature probe on the wall-mounted control panel or installed on the unit; water temperature probe always installed.
Controls installed on the right side of the unit; the KDX accessory is required for installations on the top left side.

For the unit to operate, it is compulsory to use it with a standard or advanced control.

STANDARD CONTROLS

BRIO-I SLIM	STANDARD CONTROLS			
	Board installed on board for 3-speed thermostats, for 2-pipe and 4-pipe systems	Supplied separately		KBS.3
	Board installed on board for thermostats with 0-10V analogue output for 2-pipe systems	Supplied separately		KBS.0

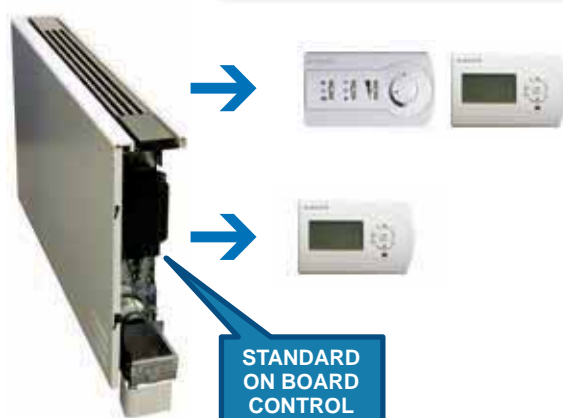

STANDARD ON BOARD CONTROL

Regulation functions

Room temperature setting, fan speed (AUTO, NIGHT, MIN, MAX) and operating mode (OFF/Summer/Winter/Auto/Fan).

- Type of system: 2-pipe, 2-pipe with integrated radiant function with heating, 4-pipe
- Manual or automatic summer/winter switching

Comfort functions

- HOT START heating function with water temperature enable
- TOO COOL cooling function with water temperature enable
- Automatic speed adjustment with continuous modulation or 4-speed control
- Operating mode stored
- Automatic dimming
- Keyboard lock

Advanced functions

Winter radiant function with fan off

- Digital input can be set as remote ON/OFF
- Digital outputs for hot and cold calls (potential-free contact)

Master/Slave Function

Centralised management of multiple fan coils through a single master unit with SLIM -Touch KPST panel.



Serial interface

- RS485 Modbus RTU serial interface, standard on KPST panel or as an accessory for KCS.M/B control; serial routing from the same control.

- RS485/BACnet gateway for communication from MODBUS RTU to BACNET IP; up to 64 fan coils with RS485 interface.

- RS485/FTT10-LonWorks gateway for communication from MODBUS RTU to LonWorks; up to 64 fan coils with RS485 interface.



Dimensions 110x78x17.5mm

Wall mounting installation

Slim-Touch KPST or KPSTW panel

with room temperature probe and integrated RS485 interface.



Electronic controls
for Yardy fan coils and Diva cassette fan coils

LIT-Touch Controls

New user experience

LIT Touch is the new Rhoss control platform for Yardy fan coils and Diva cassette fan coils, completely renewed and developed with the aim of improving the user experience.

Touch interface

The true core of the platform is the new LIT-Touch panel for wall-mounted installation, with capacitive touch technology and LED display.

With a very intuitive interface it adapts to every interior decoration requirement thanks to the two colour options: glossy black or pearl white.

The platform also includes the IR receiver with a room temperature probe for wall mounting and remote control, for ceiling or false ceiling units.

Intuitive control

The control allows the desired temperature in the room to be managed together with the fan speed, the winter-summer changeover or automatic season setting, and the display of the room temperature.

A number of integrated functions are required for room control - such as the master control of multiple slave units - digital inputs and outputs such as window contact, hot/cold call, alarm signal and optional serial interface.





Master/slave function

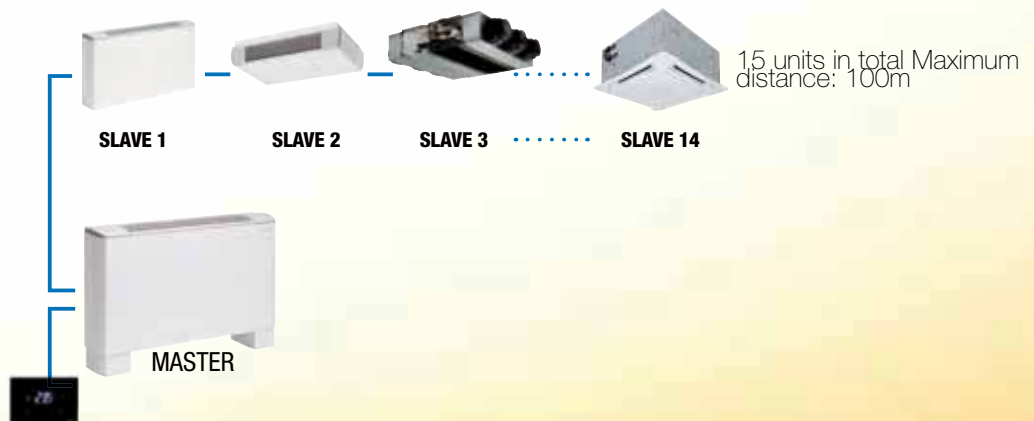

CONTROLS for fan coil units

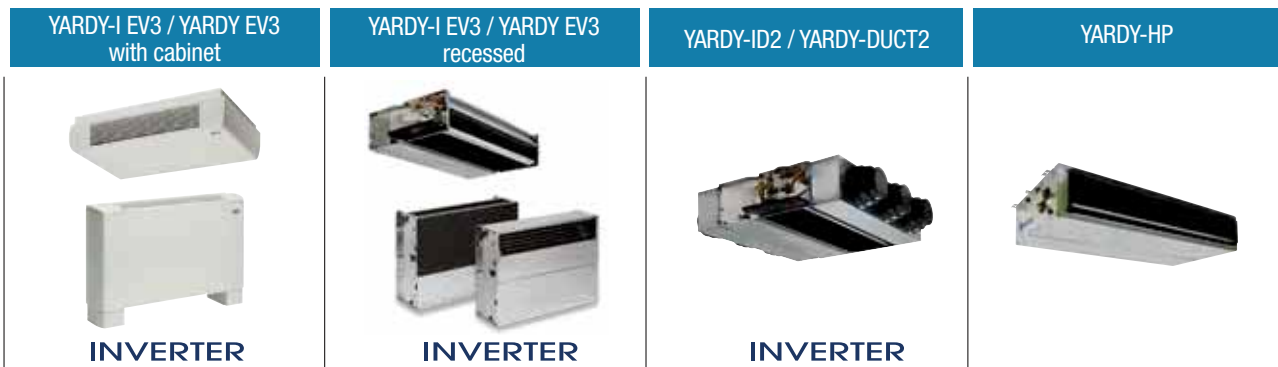

ADVANCED LIT-TOUCH CONTROLS

YARDY-IEV3 YARDY-EV3 YARDY-ID2
YARDY-Duct2 YARDY-HP

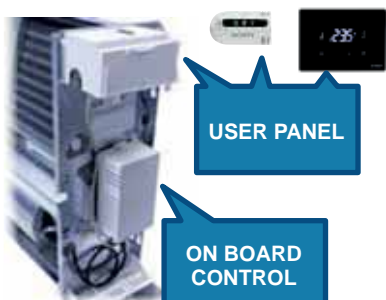

		USER PANEL	CONTROL ON BOARD	PANEL WALL MOUNTED	RECEIVER + REMOTE CONTROL	/		
		TYPE	B	KPLTW o KPLTB	KTLT + KRLT ⁽¹⁾	/		
						No user panel		
		Master/Slave Function	MASTER	MASTER	MASTER	SLAVE		
ON BOARD CONTROL		Supply	↓	↓	↓	↓		
ADDITIONAL COMPONENTS								
LIT-TOUCH CONTROL	Electronic control for: 2 pipe - 2 pipe with electrical resistance - 4-pipe installations	Factory fitted		CF/B	CF/P + KPLTB / KPLTW	CF/P + KTLT + KRLT	CF/P	
		Supplied separately		KCF/B	KCF/P + KPLTB / KPLTW	KCF/P + KTLT + KRLT	KCF/P	
	Air temperature probe installed on the unit ⁽²⁾	Factory fitted		AS STANDARD	STA1 STA3			
		Supplied separately		AS STANDARD	KSTA1 KSTA3			
	Board with 2 settable digital outputs ⁽³⁾	Factory fitted		DO2				
		Supplied separately		KDO2				
	RS485 Modbus RTU serial board	Factory fitted		SS				/ ⁽⁴⁾
		Supplied separately		KIF485				/ ⁽⁴⁾

Air temperature probe on the wall-mounted control panel, receiver or installed on the unit; water temperature probe always installed.

(1) Infrared receivers for remote control: KRLT for wall mounting installation; KRLTI for DIVA-type box installation with PLP ceiling panelling, KRLTM for installation on DIVA-type boxes with PLM ceiling panelling.

(2) (K)STA1 Air temperature probe installed on the unit as an alternative to the temperature probe on the KPLT panel or KRLT receiver, 0.6 m long; probe (K)STA3, 3 m long, is available for the YardyHP range for duct installation.

(3) 2 digital outputs: ON/OFF; Summer/Winter mode, which can also be configured as a unit alarm.

(4) For third-party BMS connection with KCF/P control, it is possible to use the RS485 serial board without a user panel.

Regulation functions

Room temperature setting, fan speed (AUTO, MIN, MED, MAX) and (OFF/ Summer/Winter/Auto/Fan) operating mode.

- Type of system: 2-pipe, 2-pipe with supplementary electrical resistance, 2-pipe with radiator or radiant panel in heating and 4-pipe.
- Manual or automatic or digital input summer/winter switching.
-

Comfort functions

- HOT START heating function with water temperature enable.
- TOO COOL cooling function with water temperature enable in 2-pipe systems.
- Automatic regulation of modulating speed for fan coils with EC motor and 3 speeds for fan coils with AC motor.
- Operating mode stored.
- Automatic dimming.
- Keyboard lock.

Advanced functions

Set-point regulation or delta set-point limitation (+/-3°C modifiable), compared to a reference value.

- Limited operation for hotel rooms.
- Thermostat ventilation or continuous ventilation (can be enabled).
- Thermostat control of a radiator or radiant panel with winter operation for 2-pipe systems.
- Up to 3 digital inputs, which can be configured as remote ON/OFF, remote summer/winter, economy, window contact, general alarm (control input).
- Additional board with 2 digital outputs: ON/OFF, summer/winter mode (potential-free contacts also settable as a unit alarm).

Master/Slave Function

Centralised management of multiple slave units via a single Master unit equipped with a control panel or receiver.

--> In the case of master/slave management, it is possible to use an air temperature probe on the master unit or the temperature probe of every slave unit, if provided.



Dimensions 120x86x17mm
Wall mounting installation

Lit-Touch KPLTB or KPLTW Panel
with room temperature probe.

KRLT receiver
with room
temperature probe.



Dimensions 95x58x30mm
Wall mounting installation

KTLT Remote control



Serial interface

RS485 Modbus RTU serial interface and serial routing from every type of control.

- RS485/BACnet gateway for communication from MODBUS RTU to BACNET IP; up to 64 fan coils with RS485 interface.
- RS485/FTT10-LonWorks gateway for communication from MODBUS RTU to LonWorks; up to 64 fan coils with KRS485 interface.



LIT-TOUCH AND SWING ADVANCED CONTROLS

DIVA DIVA-I DIVA-XLI



USER PANEL	PANEL WALL MOUNTED	RECEIVER + REMOTE CONTROL	/
TYPE	KPLTW or KPLTB	KTLT + KRLT ⁽¹⁾	/
			No user panel
Master/Slave Function	MASTER	MASTER	SLAVE

ON BOARD CONTROL ADDITIONAL COMPONENTS		Supply		↓	↓	↓
LIT-TOUCH CONTROL	Electronic control for: 2 pipe - 2 pipe with electrical resistance - 4-pipe installations	Factory fitted		CF/P ⁽¹⁾ + KPLTB / KPLTW	CF/P ⁽¹⁾ + KTLT + KRLT ⁽²⁾	CF/P ⁽¹⁾
		Supplied separately		KCF/P + KPLTB / KPLTW	KCF/P + KTLT + KRLT ⁽²⁾	KCF/P
	Board with 2 settable digital outputs ⁽⁴⁾	Supplied separately		KDO2		
	RS485 Modbus RTU serial board	Supplied separately		KIF485		/ ⁽⁵⁾

DIVA-XLI SWING



USER PANEL	PANEL WALL MOUNTED	RECEIVER + REMOTE CONTROL	/
TYPE	KPS	KTS + KRS	/
			No user panel
Master/Slave Function	MASTER	MASTER	SLAVE

ON BOARD CONTROL ADDITIONAL COMPONENTS		Supply		↓	↓	↓
SWING CONTROL	unit complete with motorised fins control, IR receiver and RS485-Modbus RTU serial board, for systems: - 2-pipe - 2-pipe with electrical resistance - 4-pipe	Factory fitted		CF/S+KPS	CF/S+KTS(+KRS) ⁽³⁾	CF/S

Air temperature probe on the unit and on the wall-mounted control panel or on the KRLT and KRS receiver; water temperature probe always installed.

(1) Not available factory fitted for Diva-XLI RE for 2-pipe systems with electrical resistance.

(2) Infrared receivers for remote control: KRLT for wall mounting installation; KRLTI for fixing on PLP ceiling panelling only for Diva and Diva-I; KRLTM ceiling mounted only for Diva and Diva-with PLM ceiling panelling.

(3) Infrared receiver for standard remote control for DIVA-XLI SWING on PLP/S ceiling panelling, KRS receiver optional.

(4) 2 digital outputs: ON/OFF, Summer/Winter mode, which can also be configured as a unit alarm.

(5) For third-party BMS connection with (K)CF/P control, it is possible to use the RS485 serial board without a user panel.

CONTROLS for fan coil units

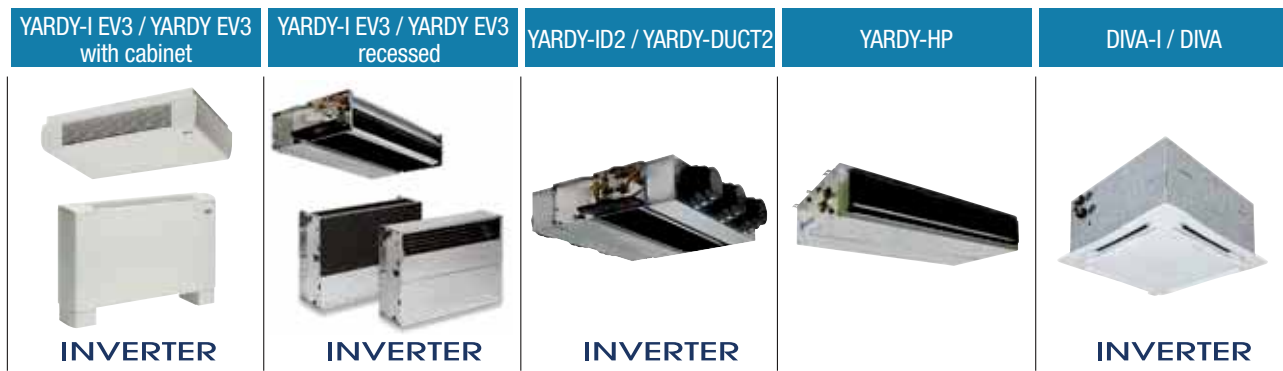

STANDARD CONTROLS

STANDARD FAN COIL (*)	INSTALLATION:	3-speed ON/OFF switch	0-10 Vdc Minimum fan analogue	Room thermostat	Thermostat output	Air sensor with remote control option	Summer/winter switch	3-way ON/OFF valve control	2-way ON/OFF valve control	Electric heater control	Ventilazione continua/termostata	2-pipe systems	4-pipe systems	Weekly time bands	Control interface for 4 fan coil units	Serial interface
KC C	→ KC - ❖ C on board	◆														
KTA TATM	→ KTA - ❖ TATM on board	◆		◆	◆		◆									
KCV2	→ KCV2 wall mounted	◆			◆		◆									◆
KTCV2	→ KTCV2 wall mounted → KBTCV2 - ❖ TCV2 on board	◆		◆	◆	◆	◆	◆	◆	◆	◆	◆	◆	◆	◆	◆
KTCVA	→ KTCVA wall mounted → KBTCVA - ❖ TCVA on board	◆		◆	◆	◆	◆	◆	◆	◆	◆	◆	◆	◆	◆	◆
KTCVR	→ KTCVR wall mounted → KBTCVR - ❖ TCVR on board	◆	AUTOMATIC SPEED MINIMUM SPEED	REGULATION ±5°C ◆	◆	◆	◆	◆	◆	◆	◆	◆	◆	◆	◆	◆
STANDARD FAN COIL	→ KTVD semi- recessed in wall	◆	MANUAL/ AUTOMATIC SPEED	◆	TIMED (A)		AUTOMATIC (B)	◆	◆	◆	◆	◆	◆	◆	◆	◆
	→ KTVDM semi- recessed in wall	◆	MANUAL/ AUTOMATIC SPEED	◆	TIMED (A)		AUTOMATIC (B)	◆	◆	◆	◆	◆	◆	◆	◆	◆
INVERTER FAN COIL	→ KTVDI semi- recessed in wall	◆	MANUAL/ AUTOMATIC SPEED	◆	TIMED (A)		AUTOMATIC (B)	◆	◆	◆	◆	◆	◆	◆	◆	◆
	→ KTVDIM semi- recessed in wall	◆	MANUAL/ AUTOMATIC SPEED	◆	TIMED (A)		AUTOMATIC (B)	◆	◆	◆	◆	◆	◆	◆	◆	◆

(A) Fan or minimum thermostat with KSO probe (accessory) start delay.
 (B) Manual summer/winter switch or by contact or automatic with KSO probe (accessory).
 ❖ Factory mounted → supplied loose

(*) The KADC analogue digital converter is available for use of standard KCV2, KTCV2, KTCVA, KTCVR controls on Inverter fan coils.



TERMINAL UNITS

Terminal unit

UTNA Platinum 013÷120

Cooling capacity: 6.4÷70 kW - Heating capacity: 4.9÷78 kW



INVERTER

- **Brushless EC fan IE5 efficiency**
- **ISO Coarse Filter 55% (G4) Airsuite Biocide**
- **ePM1 filter 50% (F7)**



Modular ductable air handling terminal units.

Construction features

- Terminal air handling unit: with modular units for horizontal or vertical installation (013-050) with ducting.
- Structure with double wall sandwich type freestanding panelling, 30mm-thick with closed cell expanded polyurethane insulation with high soundproofing and thermal insulation capacity.
- Routine machine maintenance from the bottom (for the horizontal version with installation in false ceiling or hanging from ceiling) or frontally (for the vertical version) with removable panels.
- Coil module BA (horizontal) / coil module BAV (vertical up to size 050) including: standard ISO Coarse Filter 55% (G4). All filters are supplied complete with differential pressure switch to signal filter clogging condition in compliance with European regulation no. 1253/2014. Finned coil heat exchanger, with copper pipes and 2 rows of aluminium fins for heating or reheating only and 4-6 rows for cooling and/or heating with right or left connections to be selected with order. Condensate drain pan in aluminium both for horizontal BA4R and BA6R versions and vertical BAV4R and BAV6R versions.
- SV fan module complete with EC Brushless centrifugal plenum fan with single intake directly coupled to electric motor efficiency class IE5. Static and dynamic balancing of the entire assembly, built in accordance with standard DIN ISO 1940. G6.3 balancing grade. Standard control of the rotation speed via special 0-10V analogue input. Electrical connection panel fitted as standard complete with disconnect switch, protection fuses and connecting terminal block.

Factory fitted accessories

- AIRSUITE G4- Iso Coarse Filter 55% (ISO 16890) G4 (EN 779) Airsuite with biocide capacity
- F7 - Fine dust filter Iso ePM1 50% (ISO 16890) F7 (EN 779)
- SG - Optional polypropylene drop separator at low load losses.
- TAG - Optional antifreeze thermostat.

Accessory modules

- PMA - Intake/outlet plenum with pre-cut side outlets.
- SIL - Plenum with absorbent cartridge silencer to be placed on inlet or outlet.
- MUV-PRV - Plenum with steam humidifier and external electric generator.
- BE - Additional electrical coil for connection to channel.

Separately supplied accessories

- KSG - Polypropylene drop separator at low load losses (only for BA).
- KTAG - Antifreeze thermostat (only for BA).
- KSER - Kit in combination with PMA consisting of: damper with aluminium blades and frame, fitted with seal gasket, certified class 2 according to En 1751 for fresh air (max 30%) or recirculated air and a fastening panel to PMA module. The damper is sized for treating up to 100% of the UTNA air capacity and may be positioned at the front, top or bottom of the PMA.
- KMS - Manual control for KSER damper.
- KB2R - Separately supplied additional reheat coil.



UTNAP MODEL			013	025	035	050	070	090	120	
2	Coil thermal power Only hot	BA 2R/BAV 2R	kW	4,9	8,4	11,7	16,8	25,1	32,8	39,1
1	Cooling capacity	BA/BAV 4R	kW	6,4	11,1	14,6	21,3	31,9	45,2	53,6
2	Heating capacity	BA/BAV 4R	kW	7,6	13,6	18,4	26,5	39,7	52,3	64,4
1	Cooling capacity	BA/BAV 6R	kW	8,1	14,9	20,2	27,5	41,2	56,8	68,9
2	Heating capacity	BA/BAV 6R	kW	9,1	16,6	22,8	32,2	48,3	62,1	78,2
3	Heater power	230V-1ph-50Hz	kW	3	-	-	-	-	-	-
	BE electric	400V-3ph-50Hz	kW	-	6	9	13	17	24	24
4	Air flow rate	NOM	m³/h	1300	2500	3500	5000	7500	9000	12000
		MIN	m³/h	800	1100	1500	2100	3100	5000	5000
		MAX	m³/h	2100	3700	4800	6700	10500	14400	15500
4	Useful static head.	NOM	Pa	300	300	300	300	300	300	300
5	Irradiated sound power		dB(A)	47	50	54	54	56	55	59
5	Intake sound power		dB(A)	64	65	69	68	71	70	74
5	Delivery sound power		dB(A)	70	71	75	75	78	77	80
4	SFP Int (Erp 2018<230)		W/m³/s	80	121	137	128	143	101	146
	Filtration grade EN779		G4/F7	G4/F7	G4/F7	G4/F7	G4/F7	G4/F7	G4/F7	G4/F7
	PRV Maximum steam production		Kg/h	3	5	5	8	10	15	18
	Electrical supply		V-ph-Hz	230-1-50	230-1-50	230-1-50	230-1-50	400-3-50	400-3-50	400-3-50
DIMENSIONS AND WEIGHTS			013	025	035	050	070	090	120	
	L - Width		mm	945	1245	1545	1645	1645	2045	2045
	H - Height		mm	387	387	387	504	687	837	837
	PMA - Depth		mm	480	480	480	596	780	931	931
	BA - Depth		mm	750	750	750	750	750	750	750
	BAV - Height		mm	812	812	862	962	-	-	-
6	UTNA Weight		kg	53	60	67	88	94	132	142

Data at the following conditions:

- 1 Air T in 26°C D.B.; 18.6°C W.B. (50% R.H.); water T in 7°C with Δt 5°C; nominal air flow.
- 2 Air T in 20°C D.B.; 13.7°C W.B. (50% R.H.); water T in 40°C with Δt 5°C; nominal air flow.
- 3 Air T in 20°C D.B.; 13.7°C W.B. (50% R.H.); nominal air flow.
- 4 Air T in 20°C D.B.; 13.7°C W.B. (50% R.H.); nominal air flow; 4-row coil BA/BAV 4R; clean type F7 filter.
- 5 Of SV only with work point at nominal air flow; and total head calculated in configuration: 4-row coil BA/BAV 4R; clean type F7 filter; available static 300 Pa. In accordance with EN ISO 11546-2.
- 6 SV Weight

Controls

- KPTZ - Rotating potentiometer for wall mounting installation, dedicated to manual fan speed control. The speed of delivery and return fans is calibrated with a single potentiometer.
- KTVDIM - Electronic control panel with display, for semi-recessed wall installation, including ON/OFF button, MODE, 3 Speeds+AUTO, SETPOINT change; auxiliary contacts to control ON/OFF valve in 2-pipe and 4-pipe systems; summer/winter switching; manual/automatic/ from contact; continuous/thermostat ventilation; configurable digital inputs (SCR, ECO, SIC, ALARM), weekly time bands management., complete with RS485 resident serial interface (Modbus RTU protocol).
- KRCA1 - Electronic control panel with display, for semi-recessed wall installation, including ON/OFF button, MODE, 2 Speeds, SETPOINT change; summer/winter switching with button or remote digital input; continuous ventilation, weekly time bands management room probe; 3 analogue outputs to control modulating fan, 1 or 2 modulating valves in 2-pipe or 4-pipe systems, modulating damper; 1 auxiliary contact to control on/off electrical resistance (1 stage) in 2-pipe systems + electrical resistance; 2 configurable digital inputs and 2 configurable analogue inputs. Compete with RS485 resident serial interface (Modbus RTU protocol).
- KPAU - Humidistat panel for PRV steam producer control.

Terminal unit

UTNA Platinum 013÷120

Cooling capacity: 6.4÷70 kW - Heating capacity: 4.9÷78 kW



Full Controls

- KRFCs - Electrical panel complete with: DDC programmable microprocessor regulator. BMS interfacing Integrated as standard with Modbus RTU protocol, main disconnecting switch, relay to control various users, terminal blocks for quick connection of all machine components, auxiliary circuit supply with suitable transformer 230/12-24V.

USER PANELS (for KRFCs)

- KHMIG - Interface terminal with black monochrome graphic display with LED backlighting.
- KHMIR - Interface terminal complete with integrated room temperature probe with black monochrome graphic display with LED backlighting.
- KCW - White decorative plate for control panel.
- KCB - Black decorative plate for control panel.
- KWMS - Wall mounting installation support for control panel.

Valves and actuators

- KV3V - PN40 Mixer/diverter 3-way regulation ball valves, female threaded hydraulic connections.
- KV2V - PN40 2-way regulation ball valves, female threaded hydraulic connections.
- KVMM - Actuator for ball regulation valves with modulating control 0/10 Vdc 24 Vac power supply.
- KVOM - Actuator for 230V On/Off valves.
- KDMA-S - Actuator for modulating damper 0-10V 24V with spring return.
- KDMA - Actuator for modulating damper 0-10V 24V without spring return.
- KDOA - Actuator for ON/OFF damper with spring return.

All the probes, actuators and valves on the Full Control section are also available.

Full Control regulation

The Full Control kit allows integrated management of all the functions in the UTNAP, guaranteeing total control of room comfort in a simple and complete manner:

- **Simple installation: all components are designed for on site maximum simplicity and flexibility of installation and supplied separately to not hinder handling and the installation of the units in a false ceiling and in confined spaces. The electrical panel can also be installed remotely. Pre-assembled and pre-wired at the factory on request.**
- **Easy to use: intuitive and user friendly functions and menus.**
- **Weekly time schedule.**
- **Easy start-up: pre-calibrated regulators, pre-set and tested at the factory, specifically developed to manage all functions of the chosen configuration, avoiding any complication.**
- **Easily and immediately interfaced: controller comes standard with a USB port, RS 485 for dialogue via Modbus RTU and Canbus port to develop local networks.**

The following functions are present according to the selected machine composition:

- S.Q.R. - Duct or ambient air quality sensor to manage the fan speed or automatic modulation of the dampers.
- S.C.R. - Combined temperature and humidity return air or environment probe to manage air units with humidification and/or dehumidification functions.
- T.R. - Air return temperature probe.
- S.EX. - Shut-off damper.
- F.P.S. - Standard pleated filter.
- DP - Differential clogging filters pressure switch.
- BA - Hot/cold water coil.
- V.R.CF - Hot-cold coil adjustment valve.
- T.A.G. - Antifreeze thermostat.
- SV EC - Brushless EC ventilated section.
- SV - 3-speed ventilated section.
- B.E. - Electrical coil.
- PV - Steam producer.
- T.M. - Supply temperature probe.
- KRFCs - Full Control power and regulation electrical panel.
- KHMIG - Control panel with graphic display.



UTNA SV EC

UTNA fan unit

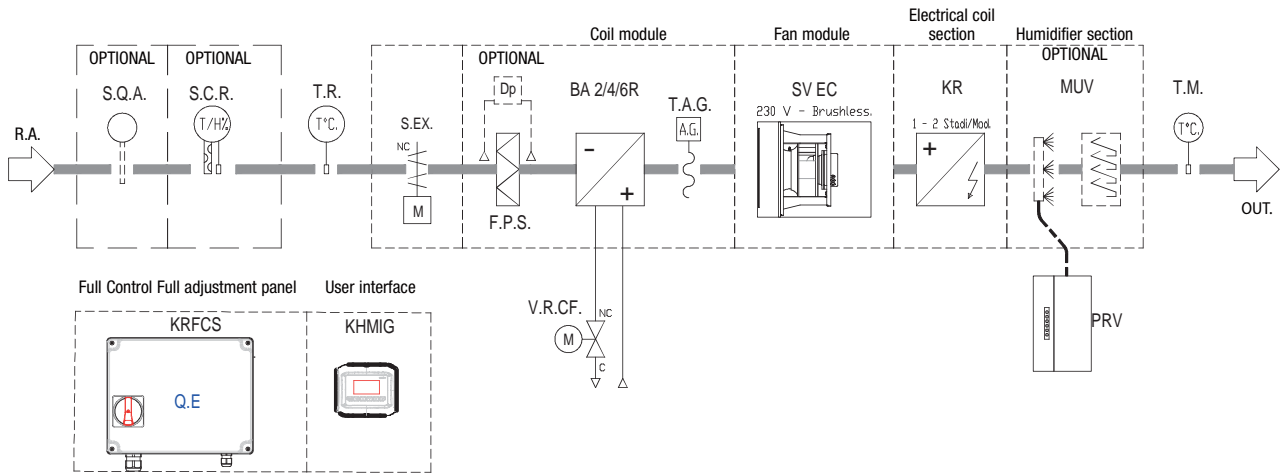

Electa-REK

UTR 20-30 - UTRR 15/45

Air flow rate: 200 - 300 - 150/450 m³/h

INVERTER



Electa-REK UTRR

- **Extremely thin: only 26 cm high for ceiling installation.**
- **Integrated air quality and humidity sensor.**
- **Very high efficiency filters in class ePM1 80%.**
- **High efficiency passive recovery unit >90%, in sensitive or enthalpy version.**
- **BLDC horizontal rotary compressor and constant-flow EC fan.**
- **Touch control as standard**



Electa-REK UTR

Fresh air terminal units with heat pump active thermodynamic recovery and opposing flow passive recovery.

Construction features

- Recovery unit:
 - First stage of heat recovery of static air-air type, sensitive or enthalpy, with opposing flows in very high efficiency polypropylene.
 - Second stage of heat pump active thermodynamic heat recovery (with R410A gas) consisting of high efficiency BLDC horizontal rotary hermetic compressor, evaporating and condensing coils with copper pipes and aluminium fins, electronic expansion valve and safety devices, 4-way valve for cycle inversion and dryer filter.
- Fans: UTR double-intake centrifugal fans with constant flow EC motor for fresh and expelled air; UTRR: EC radial fans with constant flow for fresh and expelled air, centrifugal fans with double-intake, with EC motor, for recirculation air.
- Filtering section: 80% ePM1 filters with low pressure drop air side renewal and ambient inlet, both removable at the bottom; 70% coarse filters on the recirculation side removable at the bottom, for UTRR.
- Self-supporting structure, double side sandwich panelling, internally galvanised sheet steel and externally painted (RAL 9003), with high density polystyrene insulation (20 mm thick). Circular inlets (Ø 200 mm) with sealing gasket for connection to the air ducts; lower condensate collection tank with double drain.
- Electrical adjustment and power panel integrated on the unit; electronic microprocessor control for fan speed management, temperature display, timed dirty filter management, air quality sensor management with flow modulation, humidity sensor management for dehumidification mode, summer/winter changeover and defrosting cycles.

Version

- UTR-S - Fresh air units with heat pump active thermodynamic recovery and opposing flow passive sensitive heat recovery.
- UTR-X - Fresh air terminal units with heat pump active thermodynamic recovery and opposing flow passive enthalpic heat recovery.
- UTRR-S - Fresh/recirculation air units with heat pump active thermodynamic recovery and opposing flow passive sensitive heat recovery, with integrated bypass.
- UTRR-X - Fresh/recirculation air units with heat pump active thermodynamic recovery and opposing flow passive enthalpic heat recovery, with integrated bypass.

Controls supplied separately: MANDATORY

One of the following controls is MANDATORY to operate the unit:

- KPUTB - Wall-mounted touch control panel, glossy black, to adjust room temperature, ON/OFF, summer/winter, Auto, Night, MIN, MAX speed, alarm signalling, with Wifi board, RS485 Modbus RTU interface and connection cable, up to 15 m from the unit.
- KPUTW - Wall-mounted touch control panel, pearl white, to adjust room temperature, ON/OFF, summer/winter, Auto, Night, MIN, MAX speed, alarm signalling, with Wifi board, RS485 Modbus RTU interface and connection cable, up to 15 m from the unit.



MODEL			UTR-S 20	UTR-S 30	UTRR-S 15/45	UTR-X 20	UTR-X 30	UTRR-X 15/45
Nominal fresh air flow	MAX	m³/h	235	318	150	235	318	150
Fresh air flow	MED	m³/h	210	235	90	210	235	90
Fresh air flow	MIN	m³/h	135	165	50	135	165	50
Nominal recirculation air flow	MAX	m³/h	-	-	462	-	-	462
Recirculation air flow	MED	m³/h	-	-	370	-	-	370
Recirculation air flow	MIN	m³/h	-	-	280	-	-	280
Available static pressure		Pa	100	100	100	100	100	100
① Sound pressure	MAX	dB(A)	40,0	41,5	42,0	40,0	41,5	42,0
ELECTRICAL SPECIFICATIONS								
Electrical supply		V-ph-Hz	230-1-50	230-1-50	230-1-50	230-1-50	230-1-50	230-1-50
Max. absorption		kW	1,70	1,70	1,78	1,70	1,70	1,78
② ④ PERFORMANCE IN HEATING MODE			UTR-S 20	UTR-S 30	UTRR-S 15/45	UTR-X 20	UTR-X 30	UTRR-X 15/45
Static recovery minimum efficiency		temperature/enthalpy	85%	83%	87%	69% / 36%	64% / 34%	72% / 39%
Passive recovery		kW	1,69	2,23	1,06	1,74	2,25	1,48
Active recovery nom. heating capacity		kW	2,29	2,92	2,65	2,32	2,95	2,65
Total heating capacity		kW	3,98	5,15	3,71	4,06	5,20	4,13
Absorbed power		kW	0,75	0,95	0,88	0,74	0,93	0,88
Overall COP			5,31	5,42	4,22	5,49	5,59	4,69
③ ④ PERFORMANCE IN COOLING MODE			UTR-S 20	UTR-S 30	UTRR-S 15/45	UTR-X 20	UTR-X 30	UTRR-X 15/45
Static recovery minimum efficiency		temperature/enthalpy	77%	74%	82%	69% / 28%	64% / 25%	71% / 35%
Passive recovery		kW	0,48	0,62	0,31	0,67	0,77	0,5
Active recovery nom. cooling capacity		kW	1,98	2,37	2,30	1,98	2,38	2,3
Total cooling capacity		kW	2,46	2,99	2,61	2,65	3,15	2,8
Absorbed power		kW	0,68	0,84	0,75	0,67	0,83	0,75
Overall EER			3,62	3,56	3,48	3,36	3,80	3,73
DIMENSIONS AND WEIGHTS			UTR-S 20	UTR-S 30	UTRR-S 15/45	UTR-X 20	UTR-X 30	UTRR-X 15/45
L - Width		mm	850	850	960	850	850	960
H - Height		mm	255	255	260	255	255	260
P - Depth		mm	1150	1150	1000	1150	1150	1000
Weight		kg	82	82	75	82	82	75

Preliminary data at the following conditions:

- ① In open field, 1 m from the unit, according to EN 3744; available static pressure 50 Pa.
- ② Outdoor air – 5°C RH 80%; ambient air 20°C, RH 50%.
- ③ Outdoor air 35°C, RH 50%; ambient air 27°C, RH 60%.
- ④ At the nominal flow rate.

④ OPERATING RANGE

Winter operating conditions	Aria Interna	10°C / 25°C	Aria Esterna	-20°C / 20°C
Summer operating conditions	Aria Interna	18°C / 28°C	Aria Esterna	20°C / 38°C

Electa-REK

UTR 20-30

Fresh air terminal units with heat pump active thermodynamic recovery and opposing flow passive recovery.

Temperature, humidity and ambient air quality probe.

Mandatory wall-mounted touch control panel, in glossy black (KPUTB) or pearl white (KPUTW), supplied separately from the unit.



EXTRACTION

**INTAKE
AMBIENT**

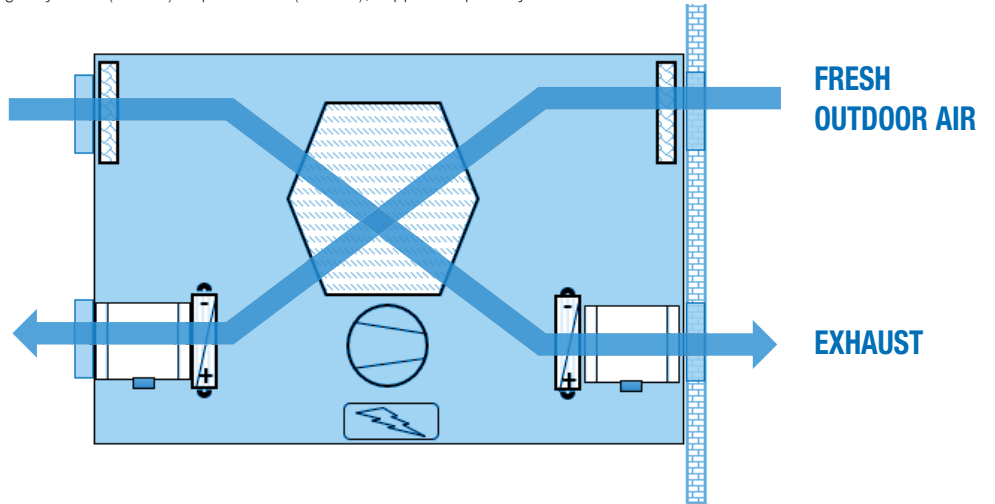

UTR 15/45

Fresh air/recirculation terminal units with heat pump active thermodynamic recovery and opposing flow passive recovery. Temperature, humidity and ambient air quality probe.

Mandatory wall-mounted touch control panel, in glossy black (KPUTB) or pearl white (KPUTW), supplied separately from the unit.



**AMBIENT
INTAKE**

**AMBIENT
RECIRCULATION**

EXTRACTION

**AMBIENT
RECIRCULATION'**

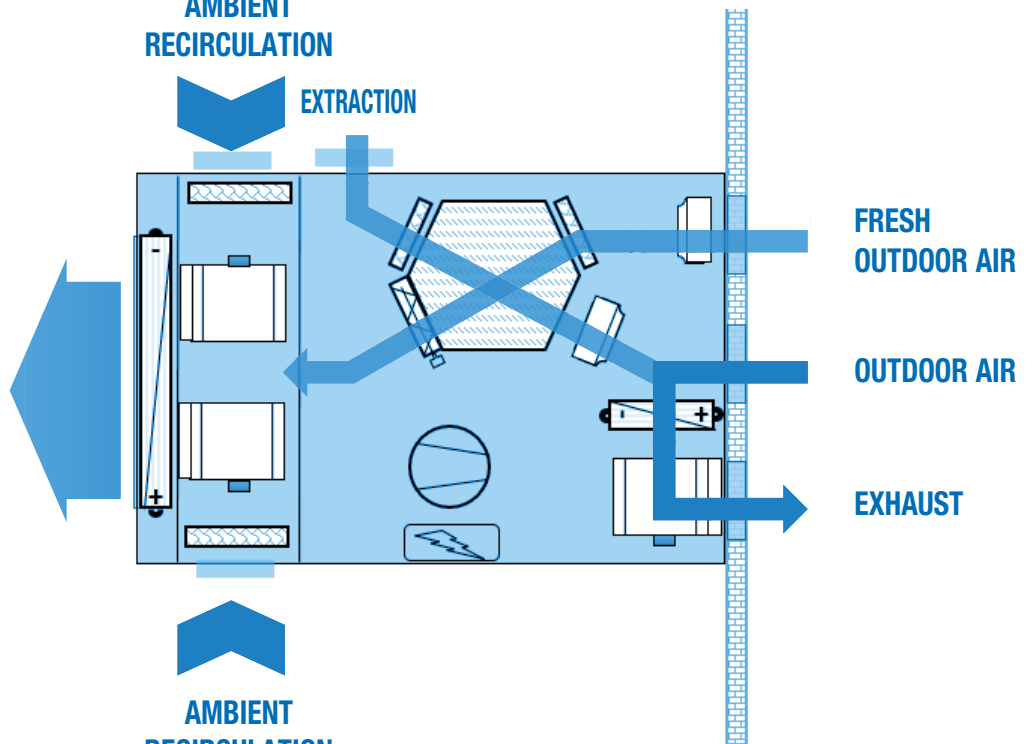



Heat recovery unit

UTNR-A Platinum 040÷500

Air flow rate: 400-4.700 m³/h



INVERTER

- Horizontal or Vertical Version
- Very high efficiency heat recovery Eurovent Certificate
- Multi-speed or Brushless EC fans
- F7 and M5 high efficiency filters
- Double sandwich wall with high insulation capacity

Fresh air terminal unit with counterflow opposing flow static heat recovery.

Construction features

- Recovery unit: very high yield static type with aluminium plates with back-current flows with close step. Extraction of side exchange pack from top or bottom depending on models and versions
- Fans: fresh air inlet and forward blade dual intake centrifugal exhaust type with a directly coupled electric motor; optionally, EC Brushless technology high efficiency electric motors. Fan unit installed on anti-vibration mountings to prevent the transmission of vibration to the structure. The EC fans can be factory set for operation with constant flow rate (specification to be provided in order)
- Structure: frame made with extruded aluminium profile with preloaded nylon joints. Sandwich buffer panels, 23 mm thick, made with galvanised sheet steel on the inside and pre-painted on the outside with thermal and acoustic insulation made of injected polyurethane, with a density of 45 kg/m³.
- Filtering section: filtration sections made of compact cell filters with low pressure drop polypropylene media, removable from the side, with ISO 16890 ePM1 55% efficiency class (F7 EN 779) in fresh flow and ISO 16890 ePM10 55% (M5 EN 779) in exhaust flow.
- Factory-installed dirty filter differential pressure switches
- Condensate drain pan made of galvanised sheet steel with condensate drain connection from the bottom.
- Integrated free cooling or thawing by-pass system. Thanks to the presence of a motorised damper next to the heat recovery, a bypass system can be created to manage freecooling or thawing depending on thermohyrometric needs or conventions

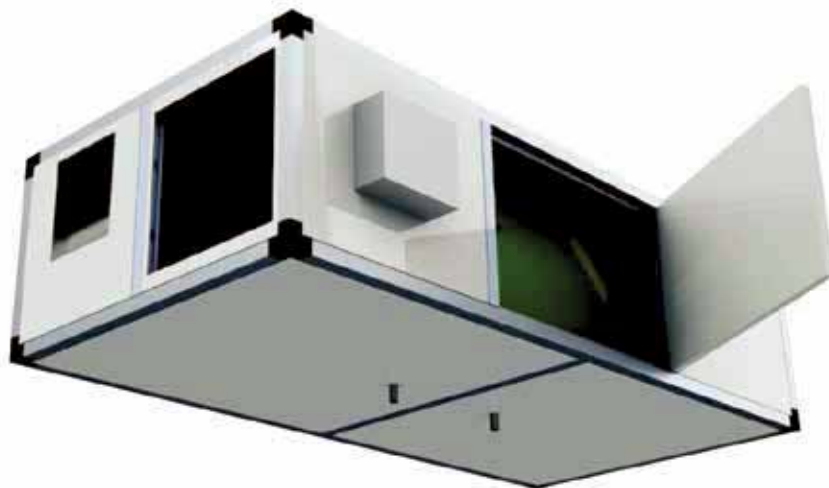

Versions

- UTNR-A/O PLATINUM - Recovery unit with opposing flow heat exchanger, horizontal installation and with standard multi-speed fans
- UTNRE-A/O PLATINUM - Recovery unit with opposing flow heat exchanger, horizontal installation and with Brushless EC fans that reduce power consumption for ventilation at equal performance.
- UTNR-A/V PLATINUM - Recovery unit with opposing flow heat exchanger, installed vertically and with standard multi-speed fans
- UTNRE-A/V PLATINUM - Recovery unit with opposing flow heat exchanger, installed vertically and with Brushless EC fans that reduce power consumption for ventilation at equal performance.

Available orientation

- 01 - Right-hand connections
 - 02 - Left-hand connections
- The selected orientation must be specified to process the job order.

Installation

- EXT- Outdoor installation including rain cover, 80 mm-high base and an outdoor electrical box (the kit does not include the roof for any additional accessory modules)



Factory fitted accessories

- BER - PRE-POST - Pre-heating electrical resistance (no frost function) installed inside, complete with filament-type safety thermostats and control relays to contain pressure drops.
For each size you may choose between 2 available power outputs
- BA - Internal hot water reheating coil.
- BAATG - Antifreeze thermostat installed downstream of the water reheating coil.
- ERF7-F7 efficiency return filter

Separately supplied accessories

- KSBFR - Section containing hot/cold water coil to reheat or recool, placed outside the machine in front of the intake vent. Includes stainless steel condensate drain pan with drain connection from the bottom.
- KSBFR + ATG - Hot/cold water coil section with mounted antifreeze thermostat.
- KSRE - Regulation damper set up for servo-control, consisting of a galvanised sheet steel frame with adjustable fins.
- KSSC - Duct silencer with a rectangular base made of glass wool covered with a protective film of glass fibre and micro-stretched sheet metal.
- KRMS - Section with three dampers for air mixing and recirculation (only for horizontal installation).
- KSPC - 4 circular connections

Heat recovery unit

UTNR-A Platinum 040÷500

UTNR-A PLATINUM MODEL		40	75	100	150	200	320	400	500
Type of Unit		Non-residential- Bidirectional							
Outdoor air filters		F7							
Return air filters		M5							
Bypass		Motorisable side bypass damper							
TECHNICAL SPECIFICATIONS									
Nominal air flow rate	m ³ /h	400	750	1000	1500	2050	3200	3800	4700
STANDARD FANS									
① Nominal available static pressure	Pa	160	120	180	160	120	180	n.d.	n.d.
① Max available static pressure	Pa	160	120	180	160	120	180	n.d.	n.d.
② Specific fan power (SFP)	W/(m ³ /s)	740	934	1105	1102	1078	1054	n.d.	n.d.
③ Sound power level	dB(A)	58	61	61	64	64	68	n.d.	n.d.
Speed N°/Regulation Type		3	3	3	3	3	3	n.d.	n.d.
Electrical supply	V-ph-Hz	230-1-50	230-1-50	230-1-50	230-1-50	230-1-50	230-1-50	n.d.	n.d.
BRUSHLESS EC FANS									
① Nominal available static pressure	Pa	160	120	180	160	120	180	200	200
① Max available static pressure	Pa	340	160	520	500	540	375	330	200
② Specific fan power (SFP)	W/(m ³ /s)	705	742	1059	1048	898	1040	949	935
③ Sound power level	dB(A)	57	60	59	61	59	64	66	68
Speed N°/Regulation Type		0-10 V							
Electrical supply	V-ph-Hz	230-1-50	230-1-50	230-1-50	230-1-50	230-1-50	230-1-50	230-1-50	230-1-50
COUNTERFLOW HEAT RECOVERY									
④ Winter Efficiency	%	83,6	82,9	81,6	83,3	83,7	86,8	84,1	84,2
⑤ Summer Efficiency	%	75,5	75,9	74,5	75,1	75,6	78	75	75,1
⑥ Efficiency Regulation EC 1253/2014	%	75,9	76,4	75	75,6	76	76,3	75,5	75,6
DIMENSIONS AND WEIGHTS									
Length/Height/Depth HORIZONTAL vers.	mm	1480/380/800	1940/480/990	1940/480/990	2200/550/1000	2200/550/1400	2500/680/1400	2500/680/1400	2500/680/1700
Weight HORIZONTAL vers.	kg	90	140	150	170	200	230	260	300
Length/Depth/Height VERTICAL vers.	mm	1480/3420/830	1940/520/1070	1940/520/1070	2200/520/1080	2200/720/1480	2500/720/1480	2500/720/1480	2500/680/1780
Weight VERTICAL vers.	kg	90	150	160	180	220	250	280	330

Data at the following conditions:

- ① Values referring to the nominal air flow rate considering the pressure drops of the heat recovery and the F7 filter.
- ② Values referring to the nominal air flow rate and Nominal available static pressure.
- ③ Radiated sound power level from casing.
- ④ Outdoor air T: -5°C, 80% RH; Ambient air T: 20°C, 50% RH.
- ⑤ Outdoor air T: 32°C, 50% RH; Amb. air T: 26°C, 50% RH.
- ⑥ Dry nominal conditions, measured according to En 308 in balanced flows. Outdoor air 5°C D.B.; Ambient air 25°C D.B.

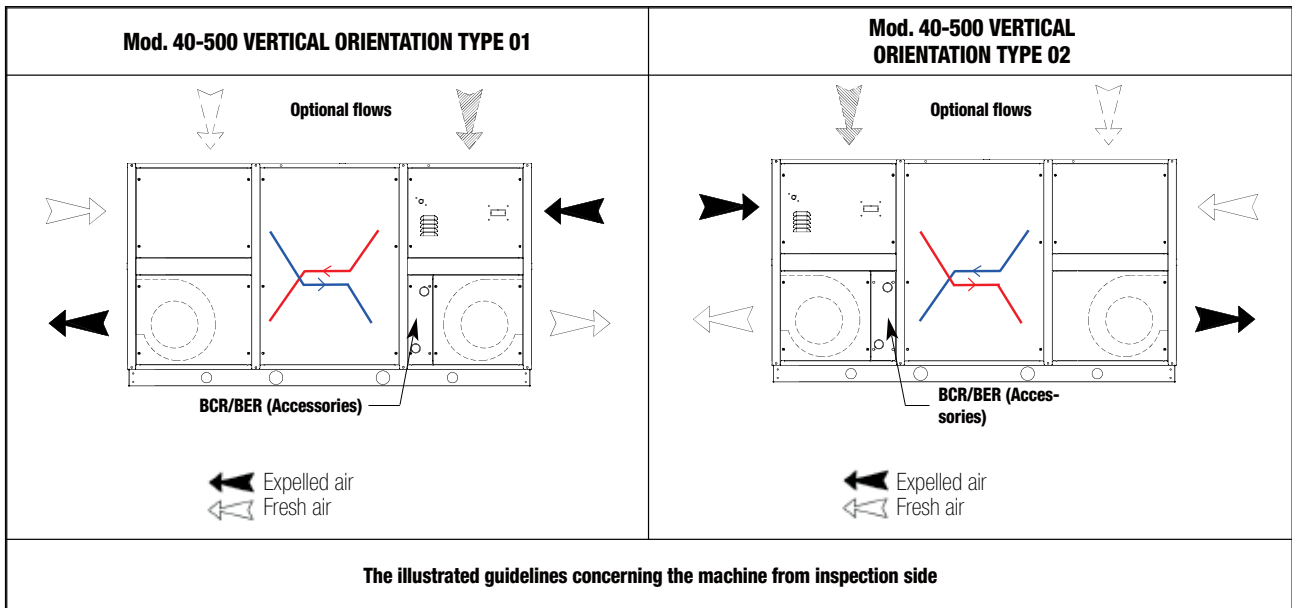
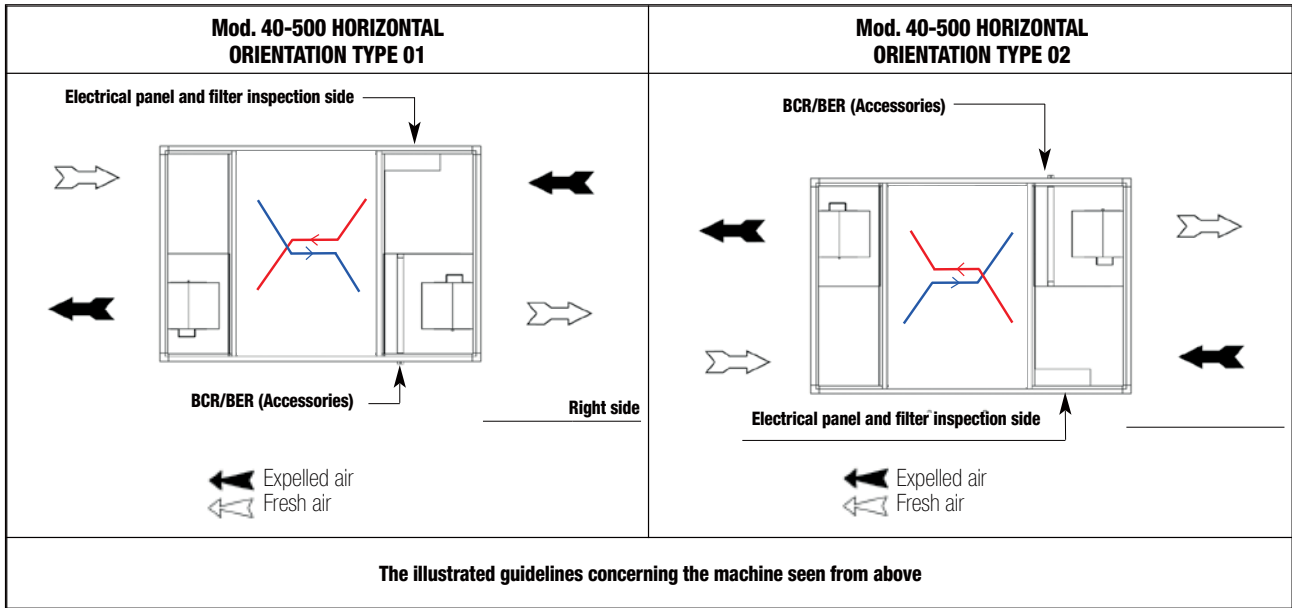

Heat recovery unit

UTNR-A Platinum 040÷500

Air flow rate: 400-4.700 m³/h



Controls

- KCV2 - Speed selector for wall mounting installation, to select from 3 speeds: Off/heating/cooling switch; 3-speed switch; 230V power supply.
- PCU - Control panel for wall mounting installation, allows the winter/summer environment temperature to be controlled, gives consent to activate or exclude the water coil (ON/OFF Valves control) or the electrical resistance. Selects the operating speed of the fan between minimum, medium, maximum and controls the freecooling function.
- PCU - Control panel for wall mounting installation, allows the winter/summer environment temperature to be controlled, gives consent to activate or exclude the water coil (ON/OFF Valves control) or the electrical resistance. Selects the operating speed of the fan through 0/10 V adjustment and controls the freecooling function.
- KPCUEM - adds a board to interface Modbus with BMS to the KPCUE control functions.

Full Controls

- KRFCs - Electrical panel complete with: DDC programmable microprocessor regulator. BMS interfacing Integrated as standard with Modbus RTU protocol, main disconnecting switch, relay to control various users, terminal blocks for quick connection of all machine components, auxiliary circuit supply with suitable transformer 230/12-24V.

USER PANELS (for KRFCs)

- KHMIG - Interface terminal with black monochrome graphic display with LED backlighting.
- KHMIR - Interface terminal complete with integrated room temperature probe with black monochrome graphic display with LED backlighting.
- KCW - White decorative plate for control panel.
- KCB - Black decorative plate for control panel.
- KWMS - Wall mounting installation support for control panel.



PCU Panel



•
KPCUE Panel



UTNRE-A Platinum

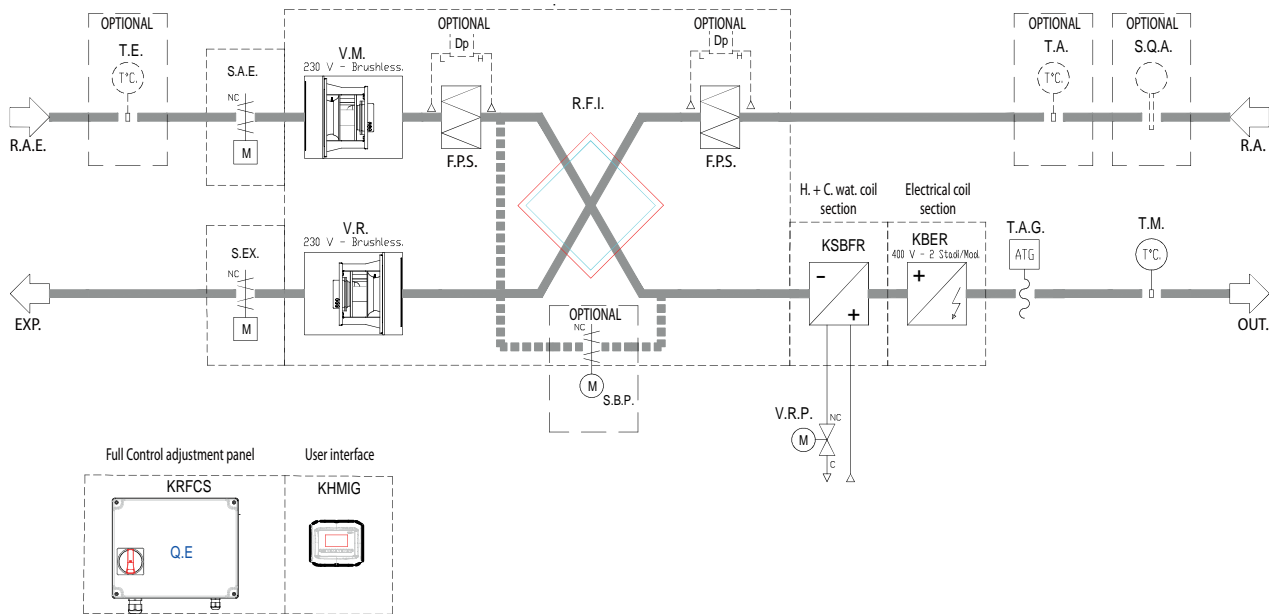

Valves and actuators

- KV3V - PN40 Mixer/diverter 3-way regulation ball valves, female threaded hydraulic connections.
 - KV2V - PN40 2-way regulation ball valves, female threaded hydraulic connections.
 - KVMM - Actuator for ball regulation valves with modulating control 0/10 Vdc 24 Vac power supply.
 - KVOM - Actuator for 230V On/Off valves.
 - KDMA-S - Actuator for modulating damper 0-10V 24V with spring return.
 - KDMA - Actuator for modulating damper 0-10V 24V without spring return.
 - KDOA - Actuator for ON/OFF damper with spring return.
- All the probes, actuators and valves on the Full Control section are also available.

Full Control regulation

The Full Control kit allows integrated management of all the functions in the UTNRA-P, guaranteeing total control of room comfort in a simple and complete manner:

- **Simple installation: all components are designed for on site maximum simplicity and flexibility of installation and supplied separately to not hinder handling and the installation of the units in a false ceiling and in confined spaces. The electrical panel can also be installed remotely.**
- **Pre-assembled and pre-wired at the factory on request.**
- **Easy to use: intuitive and user friendly functions and menus.**
- **Weekly time schedule.**
- **Easy start-up: pre-calibrated regulators, pre-set and tested at the factory, specifically developed to manage all functions of the chosen configuration, avoiding any complication.**
- **Easily and immediately interfaced: controller comes standard with a USB port, RS 485 for dialogue via Modbus RTU and Canbus port to develop local networks.**

The following are present according to the

composition of the selected machine and accessories:

- T.E. - Outdoor air temperature probe.
- S.A.E. - Outdoor air damper.
- V.M. - Supply fan.
- F.P.S. - Standard pleated filter.
- Dp - Differential clogging filters pressure switch.
- KSBFR - Hot-cold additional coil module.
- V.R.P. - Mixed coil adjustment valve.
- BCR - Integrated hot water coil.
- V.R.C - Hot coil adjustment valve.
- BER - Integrated electrical coil.
- T.A.G. - Antifreeze thermostat.
- T.M. - Supply temperature probe.
- S.Q.A. - Environmental air quality probe.
- T.A. - Environmental air temperature probe.
- V.R. - Return fan.
- S.EX. - Shut-off damper.
- KRFCs - Full Control power and regulation electrical panel.
- KHMIG - Control panel with graphic display.

Heat recovery unit

UTNR-HE Platinum 040÷400

Air flow rate: 310÷4,250 m³/h



- **Very high efficiency hygroscopic heat recovery Eurovent Certificate**
- **Multi-speed or Brushless EC fans**
- **F7 and M5 high efficiency filters**
- **Double sandwich wall with high insulation capacity**
- **Full control kit**

Fresh air terminal unit with enthalpy rotary heat recovery.

Construction features

- Recovery unit: high yield rotary type made of aluminium with hygroscopic surface. Electric induction motor with belt and pulley transmission. Recovery unit-motor assembly easily removed from the side for periodic maintenance.
- Fans: fresh air inlet and forward blade double intake centrifugal expulsion type with a continuously adjustable directly coupled electric motor; optionally, EC Brushless technology high efficiency electric motors. Fan unit installed on anti-vibration mountings to prevent the transmission of vibration to the structure. The EC fans can be factory set for operation with constant flow (specification to be provided in order)
- Structure: frame made with extruded aluminium profile with preloaded nylon joints. Sandwich buffer panels, 23 mm thick, with galvanised sheet steel on the inside and pre-painted on the outside with thermal and acoustic insulation made of injected polyurethane, with a density of 45 kg/m³. Integrated free cooling or thawing by-pass system. Thanks to the presence of a motorised damper on the heat recovery side, a bypass system can be created to manage the freecooling or thawing depending on requirements or mm thermohygroscopic conventions, with galvanised sheet steel on the inside and pre-painted on the outside with thermal-acoustic insulation made of injected polyurethane, with a density of 45 kg/m³ offering very high thermal and acoustic insulation.
- Filtering section: filtration sections made of compact cell filters with low pressure drop polypropylene media, removable from the side, with F7 efficiency class in fresh flow and M5 in expulsion flow.
- Factory-installed dirty filter differential pressure switches
- Terminal block: already part of the machine to facilitate the electrical connections, fan controls and rotary recovery.

Versions

- UTNR-HE/O PLATINUM - Recovery unit with rotary heat exchanger, installed horizontally and with standard multi-speed fans
- UTNRE-A/O PLATINUM - Recovery unit with rotary heat exchanger, installed horizontally and with Brushless EC fans that reduce the power consumption for ventilation at equal performance.

Available orientation

- 01 - Right-hand connections
 - 02 - Left-hand connections
- The selected orientation must be specified to process the job order.

Installation

- EXT- Outdoor installation

Factory fitted accessories

- ERF7-F7 efficiency return filter
- BP-Bypass control for free-cooling including: NC relay on board the panel (suitable for PCU and KPCUE) and 2 NTC probes on board the machine

Separately supplied accessories

- KBER - Reheating electrical resistance installed outside in a duct dedicated module, complete with filament-type safety thermostats and control relays to contain pressure drops.
230/1/50 single-phase electrical supply for model 040 and 075. 400/3/50 three-phase for 100÷400 models.
- KSBFR - Section containing hot/cold water coil to reheat or recool, placed outside the machine in front of the intake vent. Includes stainless steel condensate drain pan with drain connection from the bottom.
- KSBFR + ATG - Hot/cold water coil section with mounted antifreeze thermostat
- KSRE - Regulation damper preset for servo-control, consisting of a galvanised sheet steel frame with adjustable fins.
- KSSC - Duct silencer with a rectangular base made of glass wool covered with a protective film of glass fibre and micro-stretched sheet metal.
- KRMS - Section with three dampers for air mixing and recirculation (only for horizontal installation).
- KSPC - 4 circular connections.



UTNR-HE PLATINUM MODEL		40	75	100	150	200	320	400
Type of Unit		Non-residential- Bidirectional						
Outdoor air filters		F7						
Return air filters		M5						
Bypass		Motorisable side bypass damper						
TECHNICAL SPECIFICATIONS								
Nominal air flow	m ³ /h	310	640	1000	1650	2400	3200	3800
STANDARD FANS								
① Nominal available static pressure	Pa	230	130	190	160	300	180	n.d.
② Specific fan power (SFP)	W/(m ³ /s)	1409	1443	1580	1036	806	1226	n.d.
③ Sound pressure level	dB(A)	59	60	62	62	63	66	n.d.
Speed N°/Regulation Type		4	3	3	3	3	3	n.d.
Electrical supply	V-ph-Hz	230-1-50	230-1-50	230-1-50	230-1-50	230-1-50	230-1-50	
BRUSHLESS EC FANS								
① Nominal available static pressure	Pa	230	130	190	160	300	180	100
① Max available static pressure	Pa	430	280	560	600	480	460	230
② Specific fan power (SFP)	W/(m ³ /s)	1045	1263	1102	842	617	869	1029
③ Sound pressure level	dB(A)	60	61	61	63	62	65	66
Speed N°/Regulation Type		0-10 V						
Electrical supply	V-ph-Hz	230-1-50	230-1-50	230-1-50	230-1-50	230-1-50	230-1-50	230-1-50
COUNTERFLOW HEAT RECOVERY								
④ Winter efficiency temp/enthalpy	%	79/74	74/69	73/58	74/60	75/62	74/60	73,5/59
⑤ Summer efficiency temp/enthalpy	%	79/69	74/65	73/59	75/60	81/65	75/59,5	73/59
⑥ Efficiency Regulation EC 1253/2014	%	74,2	74	73	73	73,7	74,3	73
DIMENSIONS AND WEIGHTS		40	75	100	150	200	320	400
Length/Height/Depth UTNR-A PLATINUM	mm	1075/480/800	1075/480/800	1205/550/1000	1400/550/1000	1720/680/1290	2000/680/1400	2000/680/1400
Weight	kg	70	75	105	140	180	230	250

Data at the following conditions:

- ① Values referred to the nominal air flow considering the pressure drops of the heat recovery and the F7 filter
- ② Values referred to the nominal air flow and Nominal available static pressure
- ③ Sound pressure level referring to 1 m from the machine inlet in free field
- ④ Outdoor air T: -5°C, 80% RH ; Ambient air T: 20°C, 50% RH.
- ⑤ Outdoor air T: 32°C, 50% RH ; Amb. air T: 26°C, 50% RH.
- ⑥ Dry nominal conditions, measured according to En 308 in balanced flows. Outdoor air 5°C D.B.; Ambient air 25°C D.B.

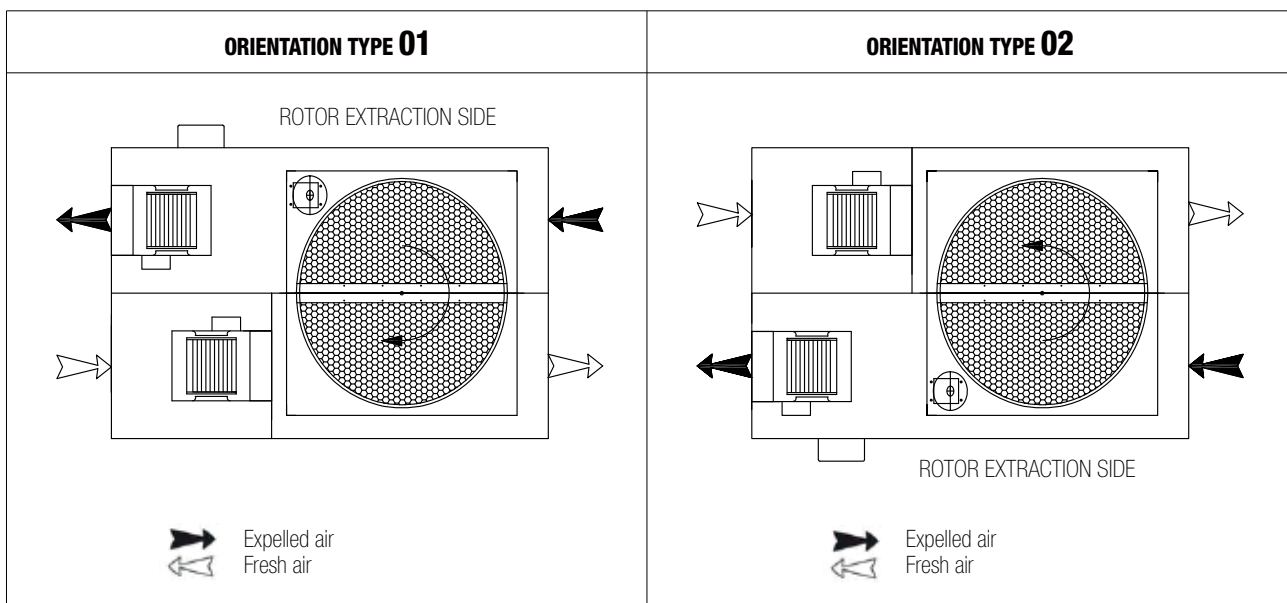

Heat recovery unit

UTNR-HE Platinum 040÷400

Air flow rate: 310÷4,250 m³/h



PCU Panel



KPCUE Panel

Controls

- KCV2-Speed selector for wall mounting installation, to select from 3 speeds (excluding model 40): Off/heating/cooling switch; 3-speed switch; 230V power supply.
- PCU - Control panel for wall mounting installation, allows the winter/summer environment temperature to be controlled, gives consent to activate or exclude the water coil (ON/OFF Valves control) or the electrical resistance. Selects the operating speed of the fan between minimum, medium, maximum and controls the freecooling function.
- PCU - Control panel for wall mounting installation, allows the winter/summer environment temperature to be controlled, gives consent to activate or exclude the water coil (ON/OFF Valves control) or the electrical resistance. Selects the operating speed of the fan through 0/10 V adjustment and controls the freecooling function.
- KPCUEM - Adds a board to interface Modbus with BMS to the KPCUE control functions.
- KPTZ - Rotating potentiometer for wall mounting installation, dedicated to manual fan speed control. The speed of delivery and return fans is calibrated with a single potentiometer (only for the EC Brushless fan version).

Full Controls

- KRFCs - Electrical panel complete with: DDC programmable microprocessor regulator. BMS interfacing Integrated as standard with Modbus RTU protocol, main disconnecting switch, relay to control various users, terminal blocks for quick connection of all machine components, auxiliary circuit supply with suitable transformer 230/12-24V.

Optional first start-up

User panels (for KRFCs)

- KHMIG -Interface terminal with black

monochrome graphic display with LED backlighting.

- KHMR - Interface terminal complete with integrated room temperature probe with black monochrome graphic display with LED backlighting.
- KCW - White decorative plate for control panel.
- KCB - Black decorative plate for control panel.
- KWMS - Wall mounting installation support for control panel.

Valves and actuators

- KV3V - PN40 Mixer/diverter 3-way regulation ball valves, female threaded hydraulic connections.
- KV2V - PN40 2-way regulation ball valves, female threaded hydraulic connections.
- KVMM - Actuator for ball regulation valves with modulating control 0/10 Vdc 24 Vac power supply.
- KVOM - Actuator for 230V On/Off valves.
- KDMA-S - Actuator for modulating damper 0-10V 24V with spring return.
- KDMA - Actuator for modulating damper 0-10V 24V without spring return.
- KDOA - Actuator for ON/OFF damper with spring return.

All the probes, actuators and valves on the Full Control section are also available.

Full Control regulation

The Full Control kit allows integrated management of all the functions in the UTNRHE, guaranteeing total control of room comfort in a simple and complete manner:

- **Simple installation: all components are designed for on site maximum simplicity and flexibility of installation and supplied separately to not hinder handling and the installation of the units in a false ceiling and in confined spaces. The electrical**

panel can also be installed remotely. Pre-assembled and pre-wired at the factory on request.

- **Easy to use: intuitive and user friendly functions and menus.**
- **Weekly time schedule.**
- **Easy start-up: pre-calibrated regulators, pre-set and tested at the factory, specifically developed to manage all functions of the chosen configuration, avoiding any complication.**
- **Easily and immediately interfaced: controller comes standard with a USB port, RS 485 for dialogue via Modbus RTU and Canbus port to develop local networks.**

The following are present according to the composition of the selected machine and accessories:

- T.E. - Outdoor air temperature probe.
- S.A.E. - Outdoor air damper.
- V.M. - Supply fan.
- F.P.S. - Standard pleated filter.
- Dp - Differential clogging filters pressure switch.
- KSBFR - Hot-cold additional coil module.
- V.R.P - Mixed coil adjustment valve.
- BCR - Integrated hot water coil.
- V.R.C - Hot coil adjustment valve.
- BER - Integrated electrical coil.
- T.A.G. - Antifreeze thermostat.
- T.M. - Supply air thermostat.
- S.Q.A. - Environmental air quality probe.
- T.A. - Air return or ambient temperature probe.
- V.R. - Return fan.
- S.EX. - Shut-off damper.
- KRFCs - Full Control power and regulation electrical panel.
- KHMIG - Control panel with graphic display.

UTNR-HE Platinum version E brushless

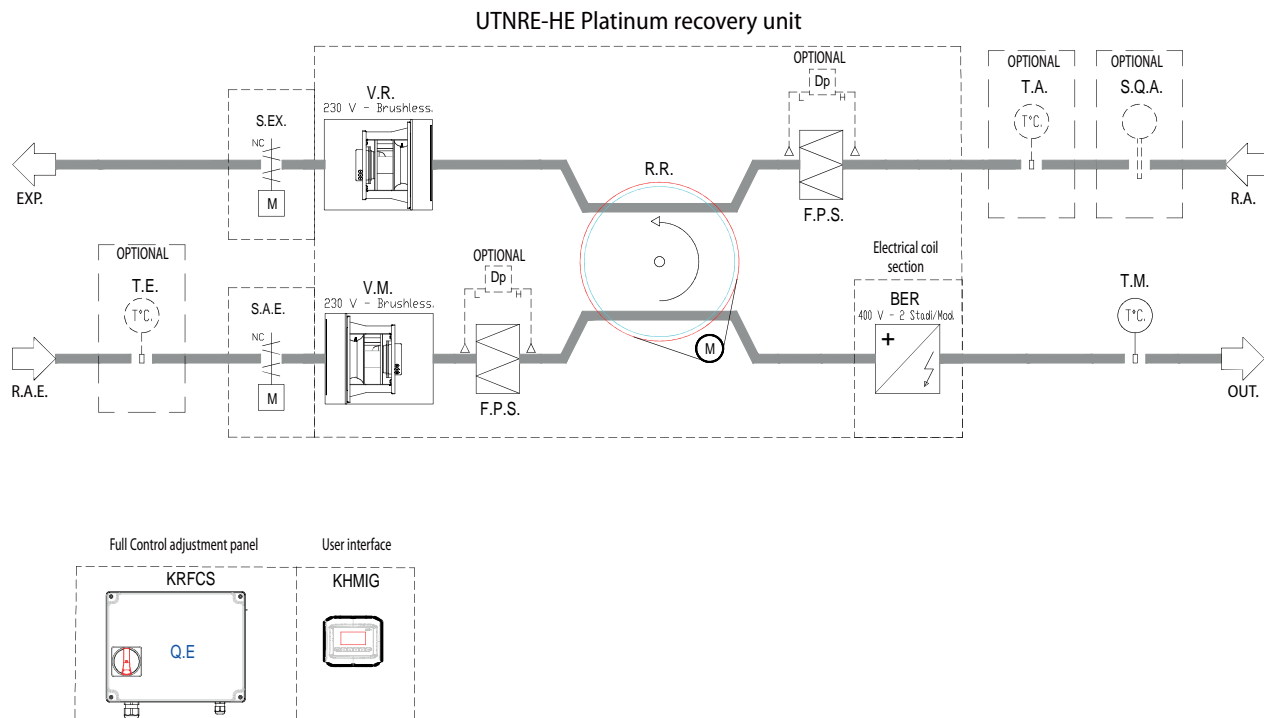

UTNR-HE Platinum

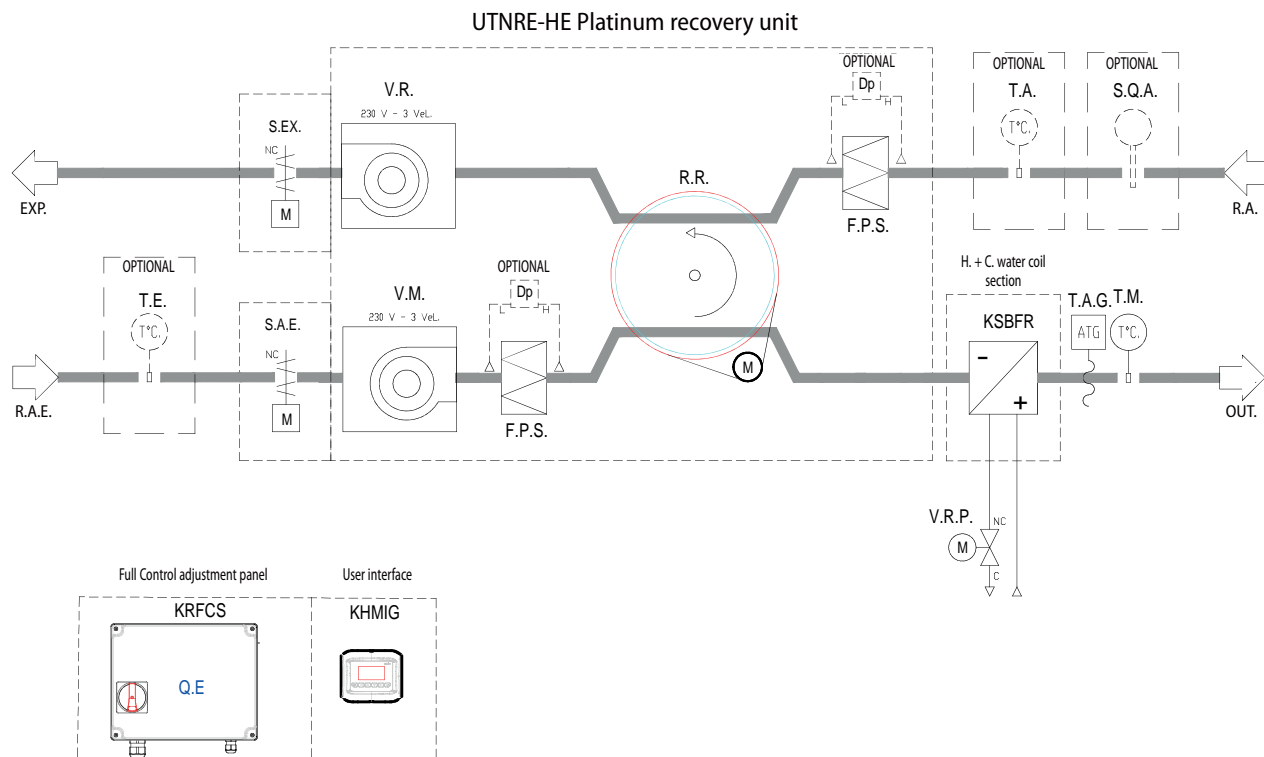

Controls

FULL CONTROL



The Full Control adjustment system aims to meet all the adjustment requirements of our units in the UTNA - UTNR A/P and HE comfort range starting from the most basic up to fully-equipped units.

MAIN CONTROL LOGIC SETTINGS

Temperature adjustment at a supply fixed point (primary air)

The Tm fixed point probe controls the supply temperature using the modulating actuator of the control valve.

“Sliding” adjustment of the supply temperature according to the ambient set-point (all air)

The supply set-point is calibrated according to the difference between the room temperature and set-point, with the authority set. This function allows the performance of a control loop with a high degree of difficulty to be improved, thereby reducing the delay with which the ambient/return probe indicates the interference that occurs in the supply and is used as a base when the ambient temperature is to be set.

Result

The supply air temperature varies according to the difference between the actual ambient temperature and that prescribed.

Benefits for the end user

The ambient temperature control is faster and more accurate, and the gap on the ambient set-point is smaller than that achieved with separate ambient/return temperature control.

Antifreeze protection function

The TAG antifreeze thermostat protects the coil from frost (in case of intervention) when the outdoor air damper closes and the unit stops

Filter clogging monitoring

The cleanliness and healthiness of the filters is constantly monitored by the differential pressure switch as required by the relevant EU regulation

2-pipe systems

In case of the mixed coil, the season must be selected from the control panel or the remote selector.

The E/I selector also lets you exclude antifreeze protection while the coil is powered by cold water.

4-pipe systems

The hot and cold valve control is in automatic sequence, with central dead band to prevent instability.

Supply summer temperature compensation in relation to the outdoor one

Adjusting the ambient/return humidity

The humidity probe on the return controls the humidity. During winter, it modulates the delivery of the steam humidifier. During the summer period it acts on the actuator of the control valve of the cold coil, thereby modulating the performance.

Temperature free-cooling

This type of function is ONLY possible if you have selected a unit with heat recovery and it is set to achieve maximum savings.

Energy will be saved in systems with internal foreign heat production in cooling mode since the typical outdoor temperatures of the winter or intermediate seasons (approx. 10 to 20°C), the ambient temperature controller controls the outdoor air dampers and expulsion on opening and recirculation on closing, thereby eliminating the added heat with a corresponding percentage of outdoor air.

The function must be activated on start-up.

UNIT		UTNA		UTNR A-HE		
FUNCTION		AP	TA	AP	TA	
CONFIGURATIONS / FUNCTIONS	2-pipe single coil (Hot, Cold, Mixed)	•	•	•	•	
	4-pipe second coil (Hot, Mixed)	•	•	•	•	
	Fan control 1, 2 or 3V	•	•	•	•	
	Fan control control (operated manually from the control panel or from the external input/potentiometer or according to the pressure/IAQ/Humidity probes)	•	•	•	•	
	On/off damper control (operated electro-mechanically when the machine is switched on and the optional antifreeze thermostat, in case of alarm)	•	•	•	•	
	Mixture chamber module damper control (potentiometer/from controller)	n/a	•	n/a	n/a	
	Separate control for double vent.	n/a	n/a	•	•	
	Recovery unit bypass command (for free-cooling control)	n/a	n/a	•	•	
	Recovery unit antifreeze control	n/a	n/a	•	•	
	On/off dehumidifier command	•	•	•	•	
	Modulating dehumidifier command	•	•	•	•	
	Coil on/off command Electric (ONLY 2-pipe versions alternative to the second hot coil for UTNA and UTNR)	•	•	•	•	
	Coil modul. command Electric (ONLY 2-pipe versions alternative to the second hot coil for UTNA and UTNR)	OPT	OPT	OPT	OPT	
	PROBES	Antifreeze Thermostat	•	•	•	•
Supply temperature probe		•	•	•	•	
Ambient/Return temperature probe and combined return/ambient temperature + humidity probe		•	•	•	•	
Ambient/Return Humidity Probe		•	•	•	•	
IAQ input probe* (Modulating damper control or fan speed)		•	•	•	•	
Channel const. pressure probe input (Speed modulation of the fans on VAV systems with separate zone dampers or pressurised control)**		•	•	•	•	
Outdoor air temperature probe outlet (for supply set-point compensation, recovery/free-cooling bypass)		•	•	•	•	
Dp filter pressure switch input		n/a	•	n/a	•	
Remote temperature recalibration potentiometer input and remote damper positioning		•	•	•	•	
Input Remote E/I selection input (ONLY 2 pipes)		•	•	•	•	
I/O OPT.	Remote On/Off input	•	•	•	•	
	Economy input (from external timer, micro window, badge reader, etc.)	•	•	•	•	
	Ext. alarm input (general alarm, fire protection etc) for emergency stop	•	•	•	•	
	Alarm repeat output (Relay)	n/a	n/a	n/a	n/a	
	Thawing input from heat pump	•	•	n/a	n/a	
	E/I switching output for heat pump	•	•	•	•	
	Pump control 1 (auxiliary, not power, for the pump or generator to service the coil/circuit 1)	•	•	•	•	
	Pump control 2 (auxiliary, not power, for the pump or generator to service the coil/circuit 2)	•	•	•	•	
	ADDITIONAL FUNCTIONS	Modbus serial communication	•	•	•	•
		Weekly time schedule	•	•	•	•
Holiday schedule		•	•	•	•	

** only with the Brushless EC fan
n/a: not available
OPT: option

Controls

FULL CONTROL

Separately supplied accessories

- KSEZM - Single-phase main disconnecting switch on the front of the electrical panel interrupts the power supply before allowing the door to be opened. It can be blocked with a padlock.
- Separately supplied accessories
- KSEZT - Three-phase main disconnecting switch on the front of the electrical panel interrupts the power supply before allowing the door to be opened. It can be blocked with a padlock.
- KPD - Differential air pressure switch (20-300Pa) to indicate the alarm when the point of intervention set to detect a dirty filter or air flow is reached.
- KTAG - Antifreeze thermostat (with brackets).
- KPOTS - Remote potentiometer for damper calibration.
- KLS - Damper manual command lever

Probes

- KATS - Ambient air NTC temperature probe (in the diagrams: TA).
- KDTS - NTC temperature probe from the channel (in the diagrams: TM/TR/TX).
- KOTS - Outdoor air NTC temperature probe (in the diagrams: TE).
- KDHS - Active humidity probe from channel with 0/10Vdc signal (in the diagrams: TUR/TUM).
- KATHS - Ambient temperature/humidity probe (in the diagrams: TUA).
- KDTHS - Channel temperature/humidity probe (in the diagrams: UR/UM).
- KAVOCS - Ambient IAQ VOC probe (in the diagrams: IAQ).
- KDVOCS - Channel IAQ VOC probe (in the diagrams: IAQ).
- KAIAQS - Ambient IAQ VOC+CO2 probe.
- KDIAQS - Channel IAQ VOC/CO2 probe.
- KDAPS - Air pressure probe.

Mixing/diverter 3-way ball PN40 VALVE.

With body and shaft in brass and chrome plated brass ball. Sealed with an EPDM ring, female THREADED hydraulic connections

- KV3V15-x_x - 3-WAY threaded VALVE. DN15 kv from 1.6 to 6.3 depending on the sizes.
- KV3V20-6_3 - 3-WAY threaded VALVE DN20 kv 6.3.
- KV3V25-10 - 3-WAY threaded VALVE DN25 kv 10.
- KV3V20-6_3 - 3-WAY threaded VALVE DN32 kv 16.
- KV3V40-25 - 3-WAY threaded VALVE DN40 kv 25.
- KV3V50-xx - 3-WAY threaded VALVE DN50 kv 40 or 63 depending on the sizes.

Adjustment 2-way ball PN40 VALVES.

With body and shaft in brass and chrome plated brass ball. Sealed with an EPDM ring, female THREADED hydraulic connections.

- KV2V15-x_x - 2-WAY threaded VALVE. DN15 kv from 1.6 to 6.3 depending on the sizes.
- KV2V20-6_3 - 2-WAY threaded VALVE DN20 kv 6.3.
- KV2V25-10 - 2-WAY threaded VALVE DN25 kv 10.
- KV2V32-16 - 2-WAY threaded VALVE DN32 kv 16.
- KV2V40-25 - 2-WAY threaded VALVE DN40 kv 25.
- KV2V50-40 - 2-WAY threaded VALVE DN50 kv 40.

Actuators for regulation BALL valves with 0/10Vdc 24Vac power supply modulating control

- KVMM25 - ACTUATOR V.DN MAX25 24V 0-10Vdc.
- KVMM50 - ACTUATOR V.DN MAX50 24V 0-10Vdc.

On/Off valve actuators, 230V TO OPERATE WITH 2-position control FAN-COIL THERMOSTATS

- KVOM25 - ACTUATOR V. DN MAX 25 230V On/Off SPDT.
- KVOM25 - ACTUATOR V. DN MAX 25 230V On/Off SPRING RET. SPST.
- KVOM50 - ACTUATOR V. DN MAX 50 230V On/Off SPRING RET. SPST.

ACTUATORS FOR MODULATING DAMPERS 0-10V 24V

- KDMAxS - ROT. DAMP. ACTUATOR 2/7/18Nm modulating with 24V spring return
- KDMAx b - ROT. DAMP. ACTUATOR 5/10/15Nm modulating without 24V spring return

ACTUATORS FOR ON-OFF 24V DAMPERS

- KDOAxS - ROT. DAMP. ACTUATOR 2/7/18 Nm on/off with 24V spring return

BASIC CONTROLS

User panels

With these accessories you can easily manage all active control functions by means of symbols and clear icons and intuitive including: change the set-point, manage summer/winter seasonal switching, manage the ON/OFF power, manage the ventilation mode, display the temperature, humidity and all the values measured by the connected probes, set a weekly program schedule or a timer for prolonged absences (holiday mode), view alarms, reset alarms and manually position any motorised dampers in modulating control.

The features described above are common to all the following control panels. All Panel controls are used for box recessed installation (BTicino 506 type). You can customise the terminal to integrate it aesthetically in environments with the KCW or KCB plates according to the price list or the several Bticino series "Living" and "Light" plaques.

- KHMIG - Vgraph control panel. Interface terminal with black monochrome graphic display with LED backlighting.
- KHMIR - Control panel with ambient temperature probe (Vroom). In addition to the functions of the previous control panel implemented a temperature probe in the panel.
- KTOUCH - Black and white monochrome touch screen control panel 320x240 pixels.
- KCOLOR - Colour touch screen control panel 320x240 pixels.
- KCW - White decorative plate for control panel.
- KCB - Black decorative plate for control panel.
- KWMS - Wall mounting installation support for control panel.



KHMIG and KHMIR



KCW

Electrical panel in a resin case, with IP55 protection, compliant with IEC EN 60204-1, complete with:

- DDC programmable microprocessor controller that can manage up to 40 I/O with Rhoss software and configuration specifically designed to make sure the optimal automatic control of all functions can be managed on the machine, via continuous comparisons made between the set values and the temperature and humidity conditions detected by the sensors. The adjustment, optimised with proportional-type algorithms plus integral (PI), assures accurate and safe operation of the air handling unit. The controller is equipped with a Real Time Clock to set the date, time and time program, with a backup battery to keep the saved data even in case of a prolonged power cut (up to 2 days). Interfaced with BMS Integrated as standard with Modbus RTU protocol.
- Main disconnecting switch.
- Fuse holder to protect single phase fan motors with power up to 1.6 kW with isolating function for phase and neutral on opening (*).
- Motor protection fuses for the motor of a rotary recovery, the 230/12V transformer and the 24V auxiliary circuit.
- Relay to control various utilities.
- Spring terminal blocks with removable connectors for quick connection of all components on the machine.
- Electrical supply 1F+N 230V 50Hz.
- Auxiliary power supply with a converter transformer 230/12-24V.
(* An external panel with specific protection and drive devices must be added required for higher power and three-phase loads .
- KRFCs - Full Control power and regulation electrical panel for UTNB-UTNA-UTNR-UTNV Single-phase Max Pow. 2x1.6 kW.



AMBIENT regulators for wall mounting with software application, display, ambient sensor, RS485 serial board and clock with control of up to 9 I/O.

- KRCA1 - Ambient regulator with integrated temperature probe to control the following functions:
 - 2 modulating coils, antifreeze, 1 modulating damper, 1 on/off resistance
 - modulating coils, antifreeze, 1 modulating fan, 1 on/off resistance
 - 2 modulating coils, antifreeze, 1 modulating resistance, 1 on/off fan
 - 2 modulating coils, antifreeze, 1 modulating fan, recovery bypass
- KRCA2 - Ambient regulator with integrated temperature probe to control the following functions:
 - 2 modulating coils, antifreeze, 1 on/off fan, 1 aux. on/off control
 - 2 modulating coils, antifreeze, 1 on/off fan, recovery bypass, 1 aux. on/off control
 - 2 modulating coils, antifreeze, 1 on/off resistance, recovery bypass, 1 aux. on/off control



- KDTR - Usable with all UTNA-V-R with 1 coil. Simple and reliable controller to be installed in the supply duct, in the same case which already holds the temperature probe and is designed to handle simple air handling units operating at a supply fixed point. Operating range 0-50°C:
- KPOTR - Remote potentiometer for damper recalibration (in combination with KDTR).

Heat recovery unit

UTNR-HP 035÷450

Air flow rate: 350÷4,500 m³/h



INVERTER

- Combined crossed flow and active thermodynamic heat recovery
- Standard air filter with G4 efficiency
- Integrated electronics



Fresh air terminal units with two-stage heat recovery unit.

Construction features

- Recovery unit:
 - First stage of the crossed flow air-air static heat recovery with aluminium heat exchanger plates; lower condensate drain pan along the entire heat treatment area.
 - Second stage of the active thermodynamic heat recovery unit with heat pump cooling circuit (with R410A gas) consisting of hermetic compressor (rotary or scroll type depending on the size of the machine), evaporating and condensing coils with copper pipes and continuous aluminium fins, electronic expansion valve, liquid separator and receiver, 4-way valve for cycle inversion, high and low pressure switches, Freon filter and liquid indicator.
- Fans: fresh air inlet and dual intake centrifugal exhaust type with a directly coupled electric motor. Fan unit installed on anti-vibration mountings to prevent the transmission of vibration.
- Structure and panels: frame made with extruded aluminium profile, Anticorodal 63 alloy, with preloaded nylon angular joints. Sandwich buffer panels, 23 mm thick, made internally with galvanised sheet steel and externally with galvanised pre-painted sheet steel (RAL 9002), with thermal and acoustic insulation made of injected polyurethane, with a density of 45 kg/m³.
- Filtering section: consisting of two class G4 filters (one on the fresh air intake and one on the ambient inlet), both can be removed from the bottom and side.
- Electrical panel: with integrated regulation and power; NTC temperature probes on both the delivery and return air circuits; micro-processor electronic control for automatic room temperature management, winter/summer switch and thawing cycles; remote control of panel up to 20 m from the unit,

Versions

Available orientation:

- UTNR-HP 01, 02 – Heat recovery unit with crossed flow and active thermodynamic double heat exchanger with 01 or 02 orientation (right connection side) or 01s or 02s (left connection side).
The selected orientation must be specified to process the job order.

Installation

- EXT - Protective roof for outdoor installation.

Factory fitted accessories

- BER - Internally installed filament type reheating electrical resistance, complete with safety thermostats and control relays. 230/1/50 single-phase for models 035÷150. 400/3/50 three-phase for models 230÷450.
- BEP - Internally installed filament type reheating electrical coil, complete with safety thermostats and control relays. 230/1/50 single-phase for models 035÷150. 400/3/50 three-phase for models 230÷450.
- PF - Differential pressure switch installed on the inlet filter to indicate a dirty filter.
- ATG - Antifreeze thermostat installed downstream of the water coil.
- EG4PF - G4 outdoor air filter with differential pressure switch.
- ERG4PF - G4 outdoor air filter and G4 return air with differential pressure switch.
- EF7 - F7 outdoor air filter.
- ERF7 - F7 outdoor and return air filter.
- EG7PF - F7 outdoor air filter with differential pressure switch.
- ERF7PF - F7 outdoor and return air filter with differential pressure switch.

Separately supplied accessories

- KSBFR - Section containing hot/cold water coil for reheat or recool, placed outside the machine in front of the inlet. Includes a stainless steel condensate drain pan with drain connection from the bottom.
- KSBFR + ATG - Hot/cold water coil section with mounted antifreeze thermostat.
- KV2V ON/OFF - 2 way valve kit with On/Off servo-control.
- KV3V ON/OFF - 3 way valve kit with On/Off servo-control.
- KSRE230 - Regulation damper consisting of a galvanised sheet steel frame with adjustable fins, equipped with 230V ON/OFF servo-control.
- KSME230R - Regulation damper consisting of a galvanised sheet steel frame with adjustable fins, equipped with 230V ON/OFF servo-control with spring return.
- KSSC - Duct silencer with wool baffles covered with glass fibre and micro-stretched sheet steel.
- KRMS - 3-damper section for operation with outdoor air at low temperature up to -20°C, with modulating servo-controls.

Controls supplied separately

- KTUP - Additional user terminal, with remote control up to 50 m, for wall mounting.
- KSCMB - Modbus serial board.

UTNR-HP MODEL		35	60	100	150	230	320	450
Nominal air flow	m³/h	350	600	1000	1500	2300	3200	4500
Available delivery static pressure	Pa	165	170	195	155	155	185	175
Available return static pressure	Pa	140	100	140	95	95	115	110
① Sound pressure level	db (A)	59/47/52	64/50/55	62/49/54	67/54/57	65/51/59	68/54/59	70/56/59
Max available delivery static pressure - Version E Brushless	Pa	270	285	295	290	365	265	270
Max available return static pressure - Version E Brushless	Pa	245	215	240	230	305	195	205
FUNCTIONAL LIMITS		35	60	100	150	230	320	450
② Standard configuration winter limit operating conditions	°C / %	MIN -10°C OUT & MIN 19°C 50% IN						
② Winter limit operating conditions with KRMS accessory	°C / %	MIN -20°C OUT & MIN 19°C 50% IN						
Summer limit operating conditions	°C / %	MAX 38°C 50% OUT & MAX 27°C IN						
Flow rate variation field	%	-10 ÷ +10						
ELECTRICAL SPECIFICATIONS		35	60	100	150	230	320	450
Electrical supply	V/ph/Hz	230/1/50	230/1/50	230/1/50	230/1/50	400/3/50	400/3/50	400/3/50
Max. absorption	A	5,3	9	13,2	20,2	10	15,4	16,4
③ PERFORMANCE IN HEATING MODE		35	60	100	150	230	320	450
Static recovery efficiency	%	62	51	50	50	50	50	50
Active recovery	W	1740	2960	5010	7690	11090	16300	17300
Total power	W	3580	5790	9410	14390	21190	30260	36010
Treated air temperature	°C	24	23	22	22	22	22	18
④ Overall COP	W/W	10,9	9,6	9,22	8,64	8,9	9,9	12,6
⑤ PERFORMANCE IN COOLING MODE		35	60	100	150	230	320	450
Static recovery efficiency	%	56	50	50	50	50	50	49
Active recovery	W	1810	2860	4890	7270	10580	15310	16990
Total power	W	2210	3450	5840	8720	12830	18390	21440
Treated air temperature	°C	19	20	20	20	20	20	21
④ Overall EER	W/W	4,2	3,9	4,2	3,9	3,9	4,1	5,01
DIMENSIONS AND WEIGHTS								
Length/Height/Depth	mm	1540/370/1240	1540/370/1240	1840/410/1440	1840/500/1440	2040/550/1690	2040/650/1690	2240/710/1890
Weight	Kg	122	125	185	228	267	281	329

Data at the following conditions:

- ① Sound pressure level assessed at 1 m from: permanent ducted socket/intake socket/compressor compartment. Generally, the operating noise level differs from the indicated values depending on the operating conditions, reflected noise and peripheral noise.
- ② Referred to the nominal flow rate.
- ③ Outdoor air -5°C RH 80%; ambient air 20°C RH 50%.
- ④ Excluding power consumption for ventilation.
- ⑤ Outdoor air 32°C RH 50%; ambient air 26°C RH 50%.

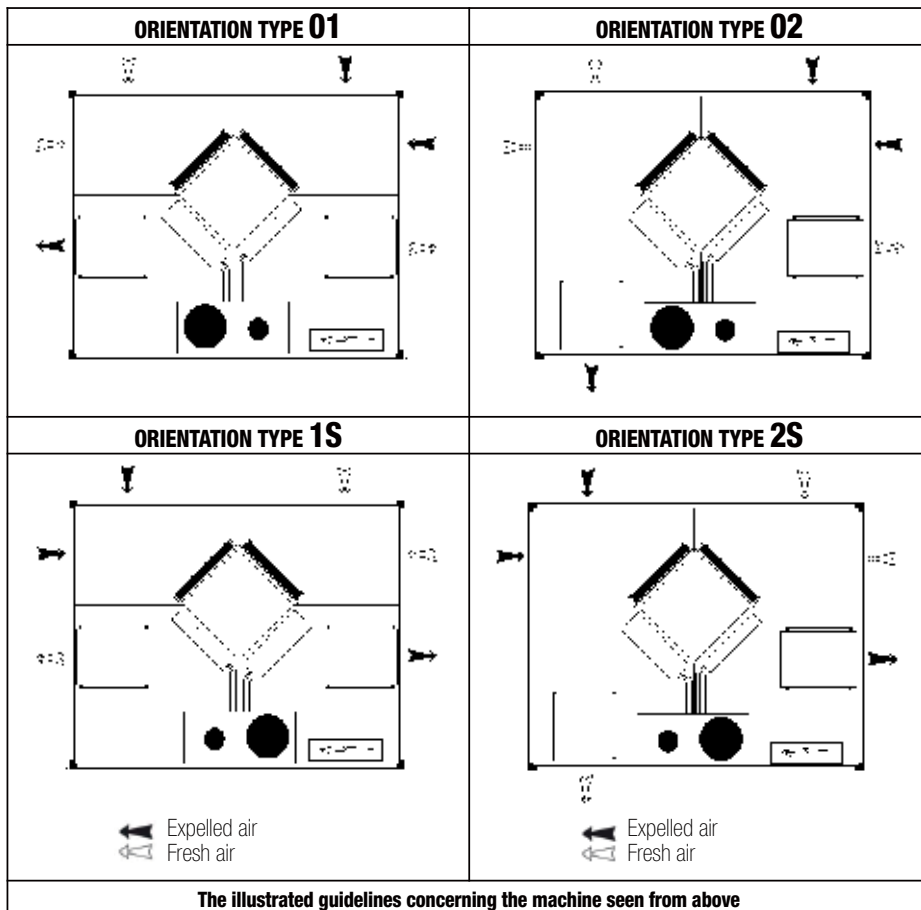

Heat recovery unit

VMC-E 025÷130

Air flow rate: 250÷1.300 m³/h



INVERTER

- Extremely compact
- High efficiency recovery
- Very silent
- Brushless DC fans

Fresh air terminal unit with counterflow static heat recovery.

Construction features

- Galvanised sheet steel self-bearing structure, insulated internally and externally.
- Recovery unit: thanks to a high yield static type heat exchanger with counterflows consisting of flat layers of special paper that allow total heat exchange, thereby recovering both sensitive and latent heat. The air flows are kept separate by relevant sealing. Maintenance is easily performed on the heat exchanger and filters thanks to side extraction.
- By-pass motorised system of the recovery unit actuated automatically by the electronic control
- Air filtration in F9 efficiency class (with G3 pre-filter) on the fresh air and G3 filter on return air.
- Integrated dirty filter signal pressure switches.
- Fans: fresh air inlet and centrifugal expulsion with BRUSHLESS EC motors that allow higher efficiency to be achieved in comparison to traditional motors with energy savings of up to 60%. 10-speed management option.
- Ducting connections with plastic round fittings.
- Incorporated electrical panel with electronic board to control the free-cooling and fan functions.

Controls

- KPST- Touch screen remote control panel
- KQSW- CO2 wall sensor for fan regulation
- KUSW- Wall humidity sensor for fan regulation

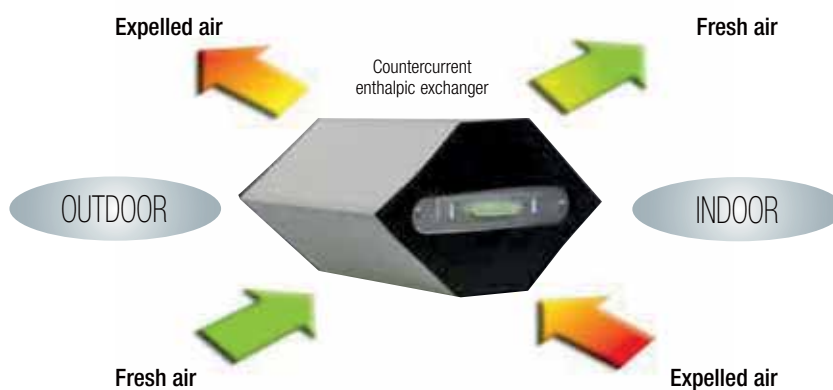



VMC MODEL		025	035	050	080	100	130
Nominal air flow	m³/h	250	350	500	750	1000	1300
Nominal available static pressure	Pa	90	140	110	140	140	140
Total nominal absorbed power	W	80	130	150	320	390	500
Total maximum absorbed current	A	0,5	0,6	0,6	1,4	2,1	2,7
Int S.F.P.	W/m³/s	812	670	547	865	881	873
① Sound pressure	dB(A)	34	37	39	42	43	44
Electrical supply	V-ph-Hz	230-1-50	230-1-50	230-1-50	230-1-50	230-1-50	230-1-50
Speed number		10	10	10	10	10	10
HEAT RECOVERY		025	035	050	080	100	130
② Winter efficiency (temp/enthalpy)	%	73/65	74/65	76/67	76/65	76/62	74/59
③ Summer efficiency (temp/enthalpy)	%	73/62	74/62	76/63	76/63	76/60	74/58
④ Dry thermal efficiency	%	73	74	76	76	76	74
DIMENSIONS AND WEIGHTS		025	035	050	080	100	130
Length/Depth/Height	mm	815/650/270	815/855/270	895/955/270	1185/1200/390	1200/1290/390	1200/1290/390
Weight	Kg	30	37	43	71	83	83

Data at the following conditions:

- ① Sound pressure level assessed at 1 m, with all 4 air nozzles ducted, on the machine inspection side and under nominal operating conditions
- ② Nominal winter conditions: outdoor air: -5°C; 80% TH. Ambient air: 20°C; 50% RH.
- ③ Nominal summer conditions: outdoor air: 32°C; 50% TH. Ambient air: 26°C; 50% RH.
- ④ According to EU Regulation 1253/2014

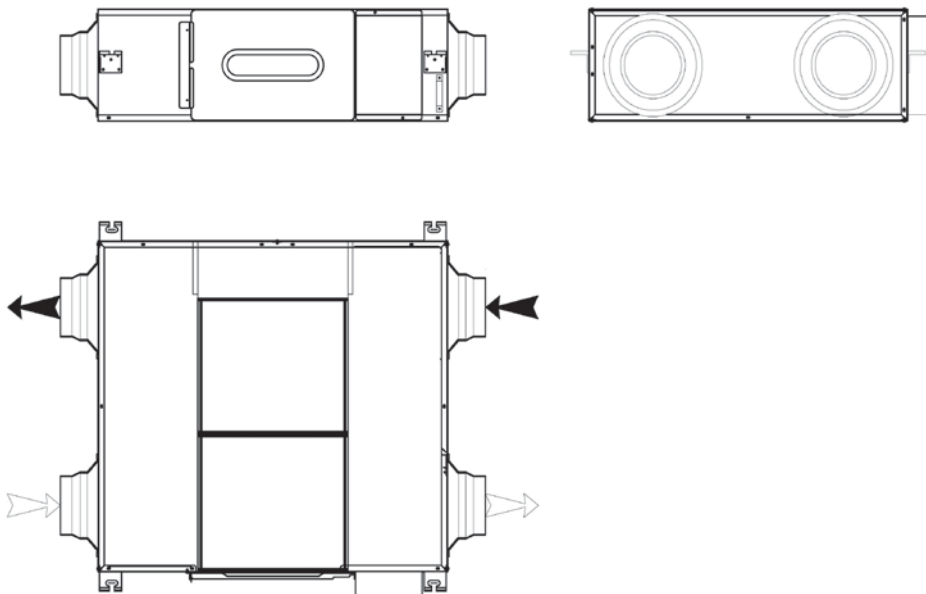

SYSTO - System Touch Manager

MTM - Multi Tecnology Manager

SIR - RHOSS INTEGRATED SEQUENCER

Rhoss Monitoring

Rhoss Web Server

A modern office interior with a large window on the left side, offering a view of a city skyline. A light-colored sofa is positioned against the wall on the right. The room features a clean, minimalist design with a light-colored floor and walls. A large blue circle is overlaid on the center of the image, containing the text.

**MANAGEMENT SYSTEMS,
CONTROL AND
MONITORING**

Touch interface with Web APP for remote control and monitoring.

SYS-TO System Touch Manager & Web APP

The entire system at your fingertips

System Touch Manager offers a simple and effective interface to control and program the conditions of the individual rooms of a building, manage the main system components and the room terminals from a single point.

The system offers a series of energy saving functions for the management of generators, the production of domestic hot water, the distribution network and the terminal units such as management with time bands that allows 10 summer/winter bands to be programmed at 2 temperature levels.

It is also possible to manage via the local network and remote monitoring via the web.

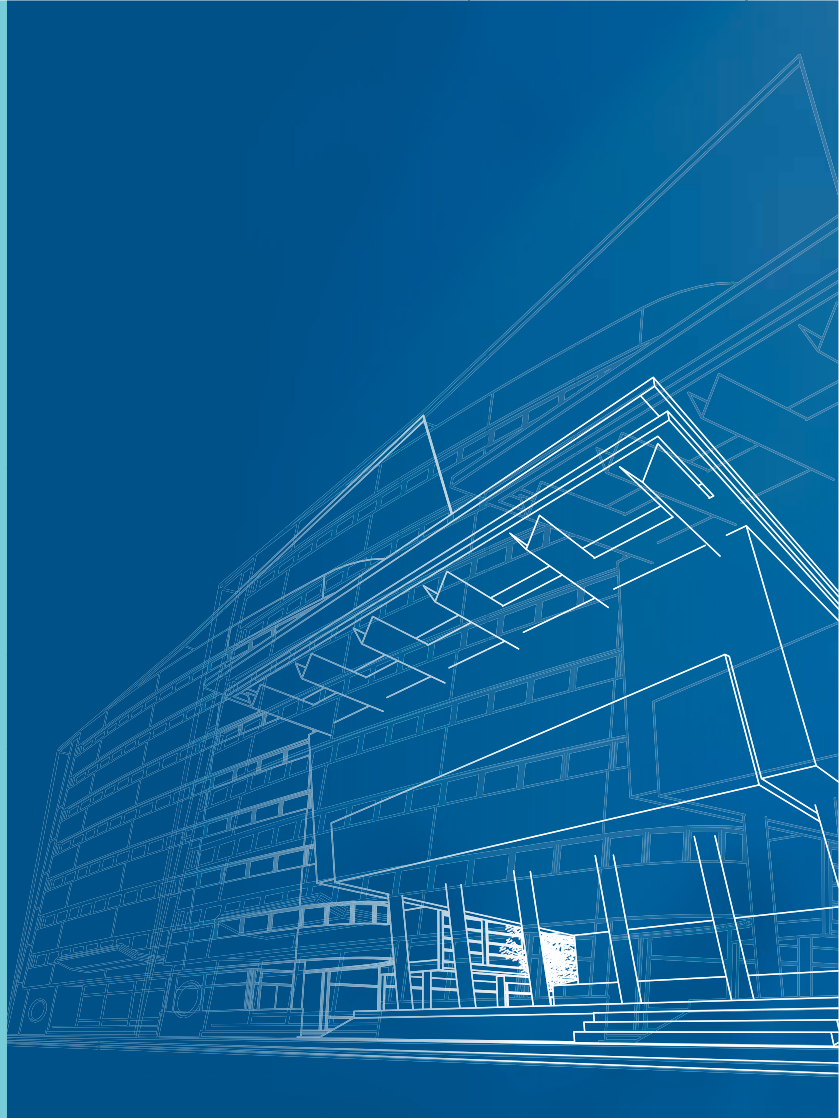

The solution

SYS-TO is an integrated management system that manages the system's main components via an electronic System Manager regulator.

User interaction with the management program is very easy; it can be managed with a simple and user-friendly display or touch screen interface.

SYS-TO enables centralised management of up to maximum 64 areas made up of fan coils with related temperature control. It is also possible to manage a cooling-chiller unit, a RHOSS multi-purpose heat pump with supplementary boiler- and up to 5 VMC units, heat recovery units or air handling units.

Solution for residential applications, small and medium services and retail:

- Villas – residences
- Hotels – restaurants – B&B
- Offices – professional offices
- Medical offices – clinics
- Shops – gyms – multi-purpose centres



System Touch Manager & Web APP



Functions

System manager, which is available in a small or medium version, enables you to:

- control the temperature detected in the various areas
- adjust the area set-point and limit the change
- limit user interaction with the area control
- control the fan coil with time bands (stop or start with two comfort levels)
- adjust the temperature of the water sent to the radiant panels in heating mode, with a mixing valve and climate compensation
- adjust the water temperature in the system side tank with 2 levels, comfort and economy, with climate compensation
- adjust the water temperature in the DHW tank
- manage the DHW side diverter valve
- communicate the set-point to the primary generator
- select the summer/winter operating mode manually, by date, outdoor temperature or digital input
- select the most convenient heat generator between the heat pump and boiler
- manage a supplementary heat source - electrical resistance - or auxiliary - boiler, system side or DHW side
- manage the DHW recirculation pump and anti-legionella sanitisation
- manage the area pumps, based on the start status or actual call in the individual areas
- start the VMC/primary air units
- send an alarm email in real time



Touch interface with Web APP for remote control and monitoring.

SYS-TO System Touch Manager & Web APP

The entire system at
your fingertips



Compatible units

Fan coils: Idrowall (with dedicated serial cable), Brio-I Slim with advanced SLIM Touch regulation, Yardy and Diva via advanced LIT-Touch regulation, via bus.
RHOSS chillers, heat pumps and multi-purpose units, via bus.
VMC units, heat recovery units with KRCA1 regulator, ADV Next Air and CTA ADVR air handling units via bus or digital input.

System management

SYS-TO allows for integrated management of the following components in 2-pipe systems and 2-pipe systems with domestic hot water (DHW) production:

Generators

- RhoSS heat pump/chiller or multi-purpose system
- Inertial buffer tank temperature probes on the system side
- Technical tank temperature probes for DHW production
- Supplementary heat source - electrical resistance - or auxiliary - boiler.
- Diverter valve for DHW
- Outdoor air temperature probe for climatic compensation or seasonal switching

Distribution network

- Area circulation pumps, for primary or primary/secondary circuit, direct or mixed, at low temperature (up to 5)

System terminals

- Control up to 64 fan coils or terminals with on-board regulation in serial connection, possibility of activating other devices in parallel with the fan coil (radiant panels in heating mode or radiators)
- Fresh air enable for VMC, Heat recovery units and Air handling units (up to 5)

SYS-TO in 4-pipe systems allows system terminals and area pumps to be managed.

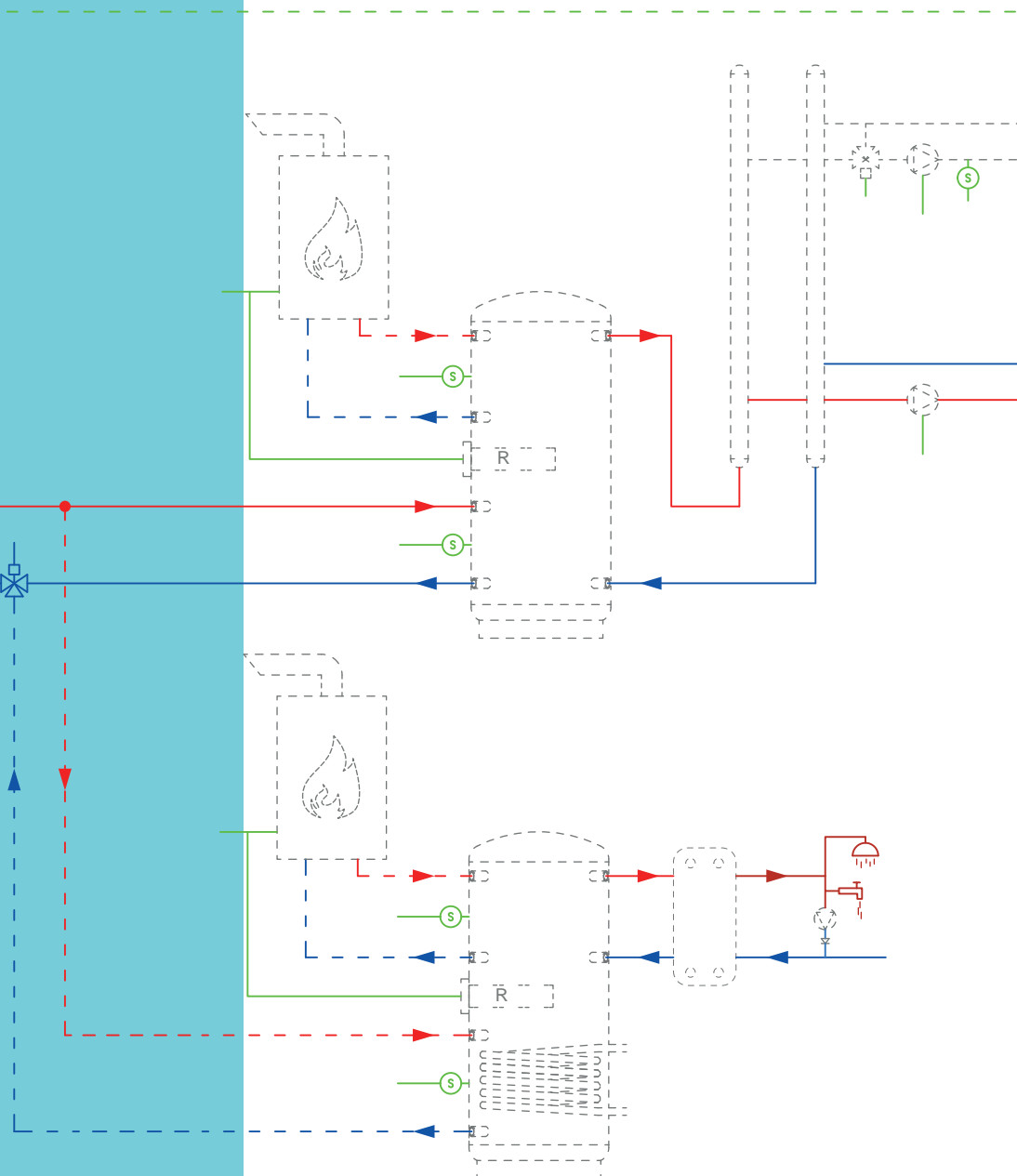

User interfaces and remote control via WEB

SYS-TO consists of the regulator (System Manager) to control room terminals (connected in serial mode) and to manage components in the field (through digital inputs and outputs) and from a user interface (HMI) available in various types. The simplest interface consists of a semi-graphical LCD integrated in the regulator, to which a remote keypad with a backlit semi-graphical LCD display can be added. The top of the range is the Touch Panel consisting of a resistive touch screen with a 7" TFT 16:9 -64 K colour recessed display installed on a support or wall-mounted, with a clean and innovative design and a lively and intuitive interface, complete with an Ethernet interface and USB port. The Touch Panel is available with the Web APP option for remote control and monitoring through any Web browser with HTML5 support.

Solution with:	Integrated semi-graphical interface	Remotable semi-graphical interface	Touch colour interface	Touch colour interface and Web APP
Web APP				
HMI				
System Manager				

Serial network with simplified routing

An RS485 ModBus RTU serial interface is required on each connected device for connection via bus. Configuring serial addresses is extremely easy; it does not require additional devices but can be done directly from the control keypad of each fan coil.

Master/slave management

It is possible to connect multiple slave units with the same ambient set-point for each Master fan coil equipped with a control or receiver.

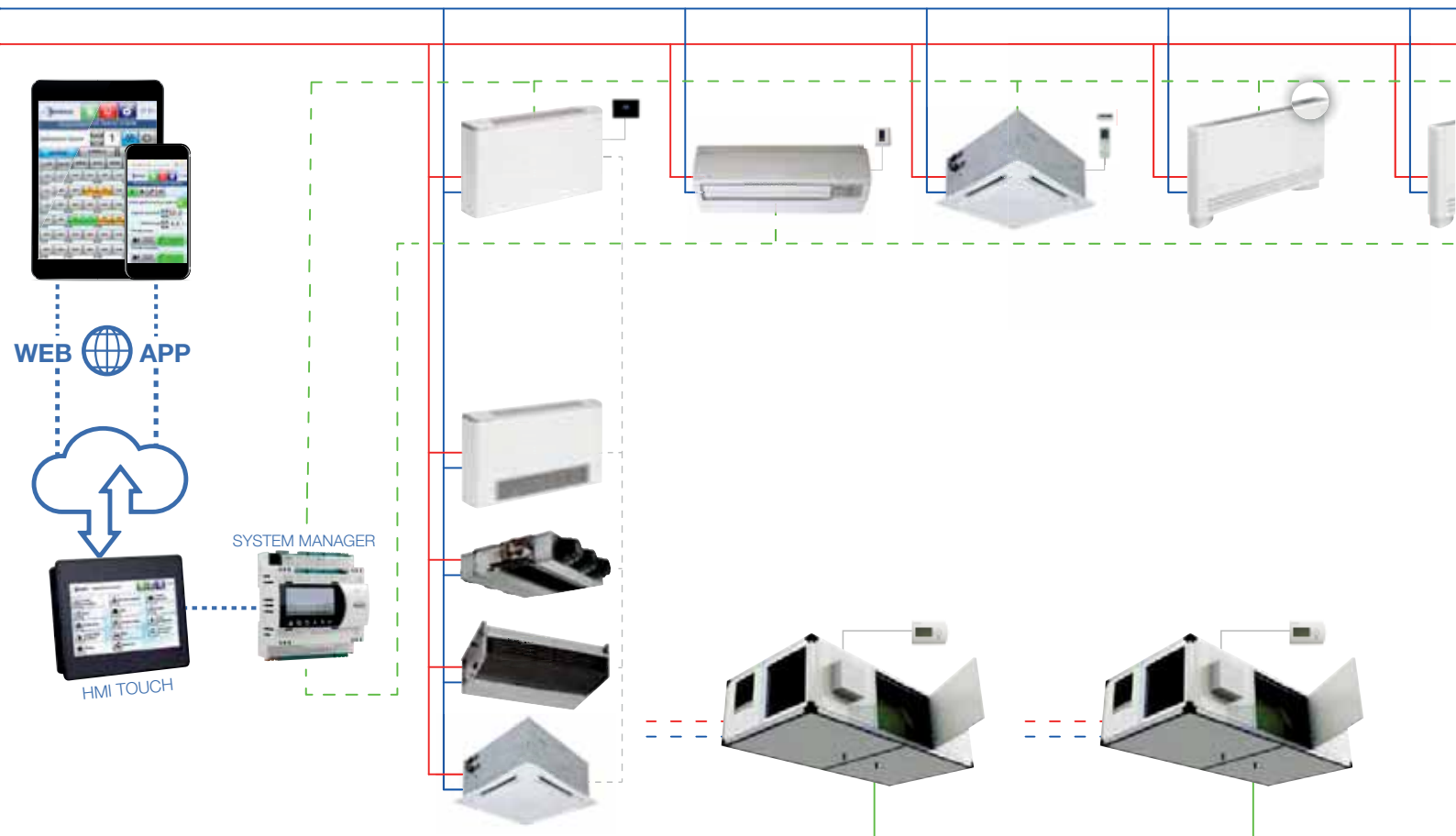

Touch interface with Web APP for remote control and monitoring.

MTM Multi Technology Manager

Intelligent
management of
Rhooss hydronic units

MTM is the new system, conceived, designed and built by RHOSS, for managing up to a maximum of 10 between multipurpose units, reversible heat pumps and chillers in perfect synergy with a guarantee of safety and reliability in modern systems.

Thanks to dedicated algorithms, MTM can effectively manage cooling and thermal loads in a stable and precise manner.

MTM is a manager and as such optimally decides the start-up sequence of the RHOSS units in the applications that the designer deals with every day.



MTM – THE OFFER

- MTM is available in two configurations but with one goal: to efficiently manage the units selected for the system.
- MTM/SI – with graphic interface and standard functions such as the display of unit operating parameters, operating status, alarms, etc.
- MTM/TI – with Touch graphic interface and advanced functions. Access to the various pages, for consultation and parameter editing, is simplified in the 7" display; it is also possible to view, through graphs, the trends of water/air temperatures and e-mail notification of any alarm can be set

MTM - Types of units managed

- Multipurpose units
- Reversible heat pumps and HT65 heat pumps
- Chillers also with freecooling and inverter technology
- Condenserless units

The units can operate at variable flow rate with the innovative VPF by Rhooss.





Ideal for using different technologies

Management of RHOSS refrigeration units present in the system by optimising the specific technologies used (chillers, heat pumps and multipurpose units).

In addition to managing homogeneous units, it is possible to combine EXP MULTIPURPOSE units with CHILLERS or HEAT PUMPS and units with different sizes and versions.

Ideal for ensuring system loads

In medium-large systems, MTM meets the required thermal loads in a precise and stable manner throughout the year.

In the case of systems with both 2 pipes + DHW and 4 pipes, where there is the demand for even unbalanced refrigeration and thermal loads, the possibility of managing units with different technology and power, optimises efficiency and the overall offer of the system.

Ideal because easy to connect

- MTM is connected to the chiller units, hydraulically connected in parallel to each other, via serial network (*).
- The user interacts in a simple way with the manager, via a graphic interface (standard or Touch).
- MTM connectivity to BMS systems is guaranteed through accessory serial interfaces, with MODBUS, BacNet MS/TP, BacNet IP, TCP/IP Modbus protocols.
- If there is a need to monitor and act on MTM from a remote station using specific web pages, MTM/TI is set up for connection to a company LAN network or to enable access via any Web browser from mobile devices (e.g. smartphone, tablet).

(*) the RS485 serial board is required in some units. See the price list for more information



Touch interface with Web APP for remote control and monitoring.

MTM Multi Technology Manager

Intelligent
management of
Rhoss hydronic units

Ideal because easy to configure

The value of a manager like MTM is also measured by the simplicity of the installation. Thanks to the WIZARD procedure introduced and the Self-learning function of the connected units, the user is guided through the first device configuration to be immediately ready and operational.

Ideal for any installation

MTM is designed, in the standard configuration, to automatically start-up the hydronic units. Once the individual units present are recognised, it decides which strategy to use to maximise efficiency, for example preferring freecooling units if the outdoor temperature is favourable, inverter technology for the best power modulation or simultaneous operation (cooling+heating) of the multipurpose units. It is also possible to "customise" unit management, according to the customer's preferences or type of system, even with the Backup function in the most sensitive installations. The Booster function, which can be set if there is a Backup unit, can meet the various peak loads that may occur throughout the year.

Ideal for service

- MTM simplifies SERVICE operation as the implemented algorithms enable optimal operation of the group of units even in case of partial dysfunctions.
- MTM provides the history of the alarms and, in case of MTM/TI version, also the notification function by mail/message to designated users.

Ideal for having the situation under control

MTM is accessible:

- Directly from the device (KMTM/SI and KMTM/TI) through the present graphic interface.
- From a BMS connected to the device (KMTM/SI and KMTM/TI) through serial interfaces Through the dedicated Web pages (KMTM/TI only).
- In this case, the pages can be accessed via LAN connection or WEB APP

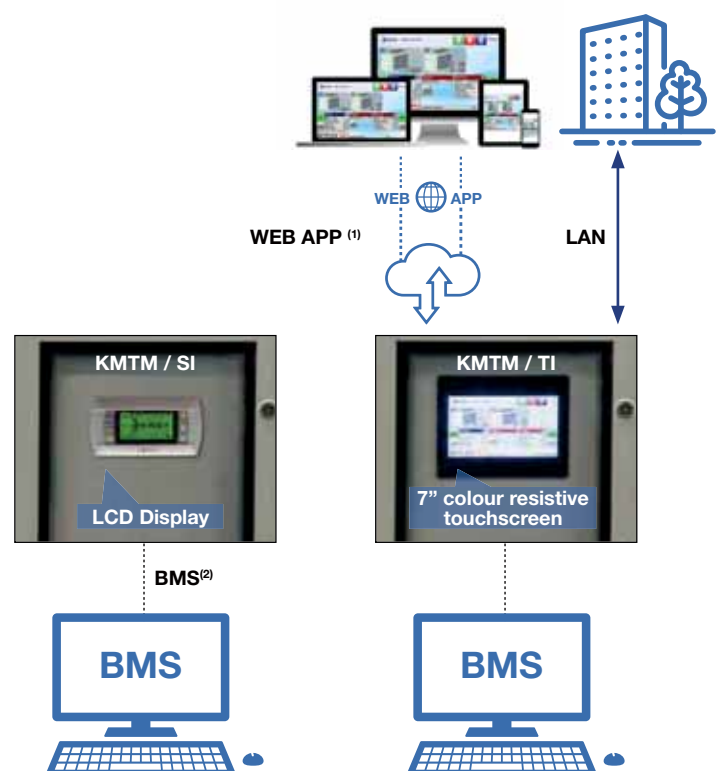

(1) service can be activated (2) via interface, using the MODBUS, BACNET IP, MODBUS TCP/IP protocols

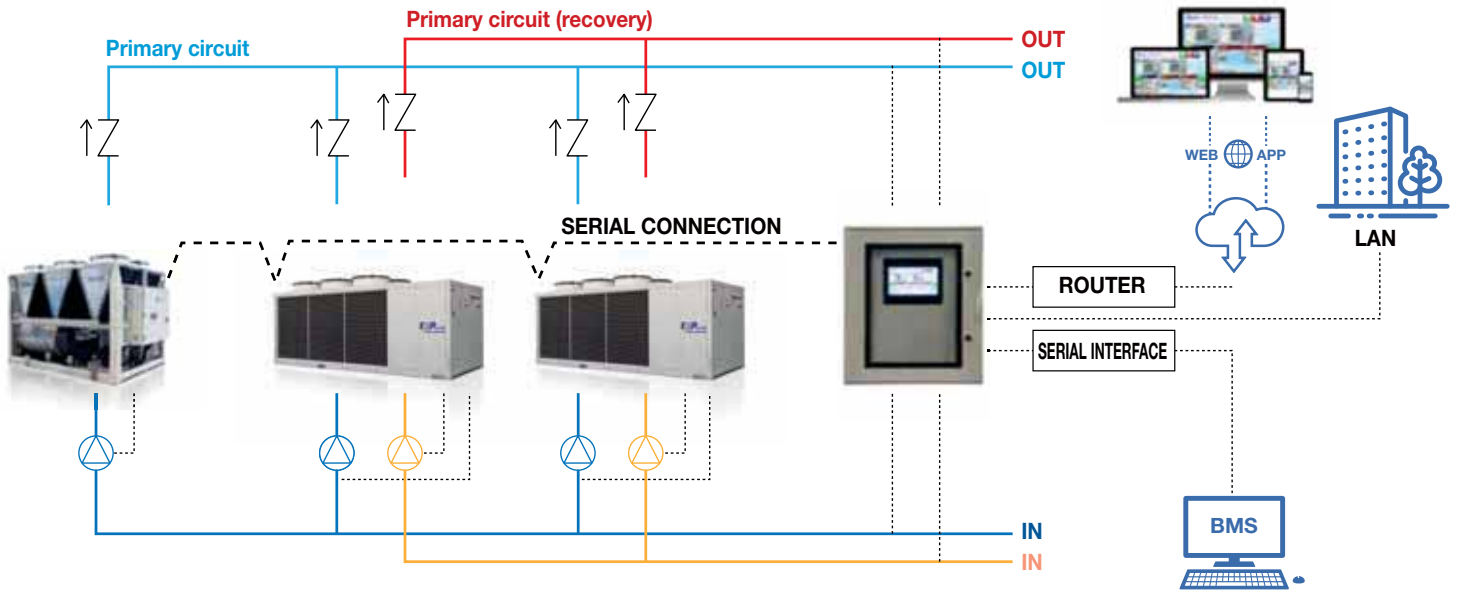

Simplified example of a 4-pipe system with one chiller and two EXP multipurpose units managed by KMTM/ TI. The system provides for the units to operate throughout the year, with the production of cold and hot water at the same time or independently.

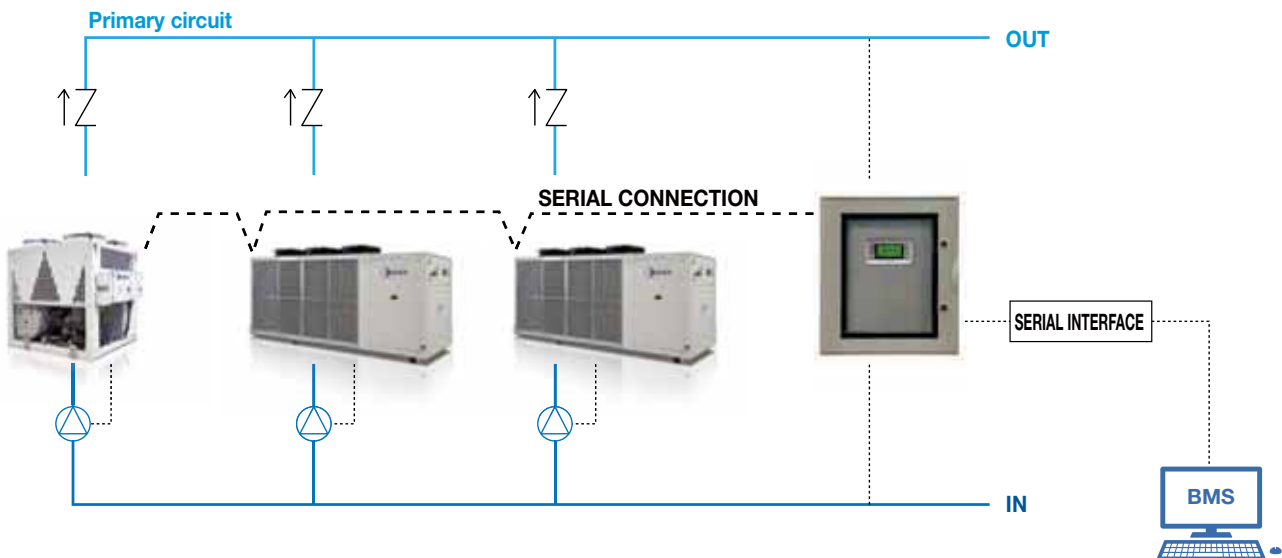

Simplified example of a 2-pipe system with two heat pumps and one chiller managed by KMTM/SI. The system provides for summer operation with the two heat pumps and the chiller operating in SUMMER mode and winter operation with the inversion of the heat pumps and the shutdown of the chiller.

MTM - MULTI TECHNOLOGY MANAGER



TYPE AND UNIT MANAGEMENT	KMTM/SI	KMTM/TI
Maximum number of units	10	10
Management of CHILLERS, HEAT PUMPS, EXP UNITS, FREECOOLING UNITS, CONDENSERLESS UNITS	•	•
Advanced management of STANDARD+FREECOOLING CHILLERS	•	•
Advanced management of EXP MULTIPURPOSE UNITS+CHILLERS in 4-pipe systems	•	•
Advanced management of EXP MULTIPURPOSE UNITS+HEAT PUMPS (connected to main circuit) in 2-pipe+DHW systems	•	•
Advanced management of external pumping unit(s), primary side. Possibility of managing single pump for single unit or single pump for group of units.	•	•
CONTROL LOGIC		
STANDARD, based on the type of units connected, used technology, hours worked	•	•
ADVANCED, based on customisable SATURATION or EQUALISATION logics	•	•
Choice of the type of balancing of the hours worked	•	•
BACKUP unit management	•	•
Advanced management of units with VPF by RHOSS (primary side variable flow rate)	•	•
REGULATION		
Control on leaving or return water temperature	•	•
Adjustment with climatic compensation	•	•
Advanced double set point, shifting set point	•	•
Advanced function of forced limitation of the absorbed power	•	•
ACCESSIBILITY TO THE MTM DEVICE		
Multilingual user interface	•	•
Standard graphic interface	•	
Touch screen graphic interface		•
Access from BMS system (including optional serial interface with specific protocols)	•	•
Access from dedicated web pages (MTM in LAN connection with the building where the units are installed)		•
Access from dedicated web pages via WEB APP (Enabling is optional)		•
UNIT MONITORING		
Status display, setting and reading of the most important unit parameters	•	•
Reading of active alarms of the single units and alarms log display	•	•
Alarm notification by e-mail		•
Graphs of the main variables (e.g. water/air temperature trend of the units)		•
Sending PDF of periodic report (e.g. trend of temperature water/air of each unit)		•



SIR - Rhoss Integrated Sequencer

Chiller management software

MASTER/SLAVE control up to 4 Rhoss hydronic units

Summer/winter mode for heat pump units

System set-point management

Control of all operating parameters

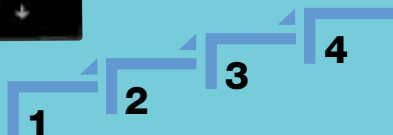

SIR – THE OFFER

- The SIR integrated Sequencer makes it possible to manage up to 4 parallel plumbing chillers in medium/large HVAC systems.
- The optimisation of operating times and the insertion of the individual units is controlled by logics integrated in their management software, guaranteeing reliability over time.
- The software at the heart of the system was designed and tested by the Rhoss R&D structure and is able to acquire and manage the main variables of the connected water chillers.
- Depending on the product range, the units of the group can interface with the main BMS on the market, for them to be monitored, to guarantee full control of each type of system (verify the option in the product documentation).



SIR - Types of units managed

- Chillers also with inverter technology
- Reversible heat pumps and HT65 heat pumps
- Polyvalent units
- Condenserless Units

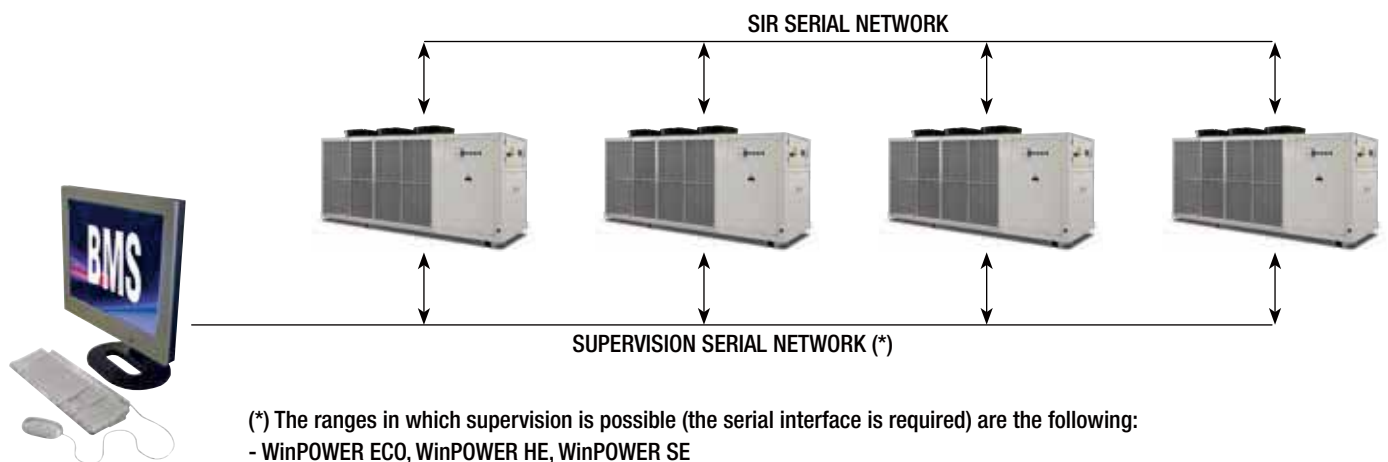

(*) The ranges in which supervision is possible (the serial interface is required) are the following:

- WinPOWER ECO, WinPOWER HE, WinPOWER SE
- Z-Power
- FullFLOW DX, Z-Flow E, FullFLOW VFD (1+i), FullFLOW ECO VFD (1+i)
- FullPOWER HE, FullPOWER SE, FullPOWER VFD, FullPOWER VFD (1+i)
- TurboPOWER

For the other ranges, contact Rhoss SPA for more information.

RHOSS MONITORING: Mobile - Cloud - Real time

Remote monitoring

- Remote control of cooling units and air handling units
- 3 different solutions for remote monitoring
- Connection via mobile phone or smartphone
- Web interface with Cloud service
- Status display in real time
- Data logger function
- Alarm and malfunctioning alerts
- Installation of the DIN bar on the device inside the unit's electrical panel.

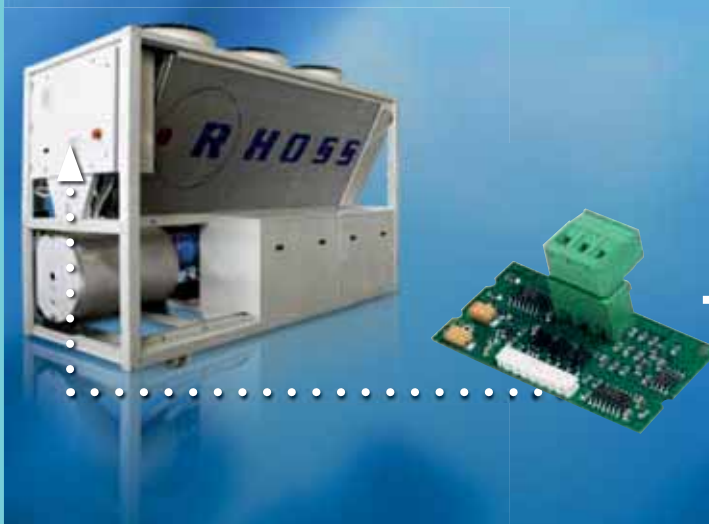

**RHOSS COOLING UNIT +
SERIAL INTERFACE**

MONITORING	MAIN FEATURES	CONTROL DEVICE	INTERNET CLOUD SERVICE	SIM CARD
MOBILE for residential and small-size service sector applications	Input/output management via mobile phone and editing by SMS . Alarm and malfunctioning alerts. Reading up to 8 values.		Not provided (only SMS management available)	
CLOUD for residential and service sector	Management of the main parameters and editing via internet interface or via APPS IOS and ANDROID. Alarm, malfunctioning display with hourly frequency and trend logs. Reading up to 8 values.	KMMC - Remote Mobile/Cloud control device with slot for SIM CARD	Internet Cloud service by subscription (minimum length 1 year)	Responsibility of the user or by subscription (not required if local Internet connection is used)
REAL TIME for the service and industrial sector	Management of the parameters and editing via internet interface or via APPS IOS and ANDROID. Real time alarm, malfunctioning display and trend logs. Reading up to 100 values.	KMRT - Real Time control device with slot for SIM CARD	Obligatory	



**CONTROL DEVICE +
SIM card**

MOBILE

MANAGEMENT VIA SMS





CLOUD

REAL TIME

MANAGEMENT WITH INTERNET CLOUD SERVICE VIA WEB BROWSER OR WITH iOS AND ANDROID APPS



CONTROL DEVICE	Serial interface on Rhoss unit	Remotely manageable inputs/outputs	Monitorable Rhoss units		Readings
 <p>KMMC - Remote control device for Rhoss Monitoring Mobile or Cloud, installation on DIN bar (4 modules) within the unit's electric panel, slot for SIM CARD, status and inputs/outputs signalling LED, antenna with 3m cable, protection degree IP40, GSM dual band module 900-1800 MHz, Buffer battery (1 hour approximately); serial ports; Power supply not included.</p>	RS485 Serial interface (accessory KRS485 or SS)	<ul style="list-style-type: none"> • 2 relay outputs configurable and activated via SMS • 2 digital inputs for external alarms • 1 configurable analogue input (0-10 V, 0-20 mA, 4-20 mA) 	1	<ul style="list-style-type: none"> • cooling unit • air handling units 	up to 8 readings
 <p>KMRT - Remote control device Rhoss Monitoring Real Time, installation on DIN bar (6 modules) within the unit's electric panel, slot for SIM CARD, 3 status signalling LEDs, antenna with 3m cable, protection degree IP40, GSM/GPRS Modem, serial ports; Watchdog hardware, Real Time Clock; Power supply not included. NOTE: the KMRT device is fitted with additional Ethernet interface for using local Internet connection (without SIM CARD).</p>	<ul style="list-style-type: none"> • RS485 serial interface (accessory KRS485 or SS) • Ethernet Interface (accessory KBE) [only if Ethernet is available on site] 	Not available	5	<ul style="list-style-type: none"> • cooling unit • air handling unit 	up to a total of 100 readings

RHOSS WEB SERVER

Control and monitoring via ETHERNET



RHOSS WEB SERVER

- Managing a single cooling unit via ETHERNET
- Web page with unit status and detailed tabs with:
 - synoptic of the main components
 - graphic trend of the main variables
 - possibility of modifying the main parameters (on/off, mode, set-point)
 - status and alarms reset
- Installation of the ethernet interface inside the unit's electrical panel

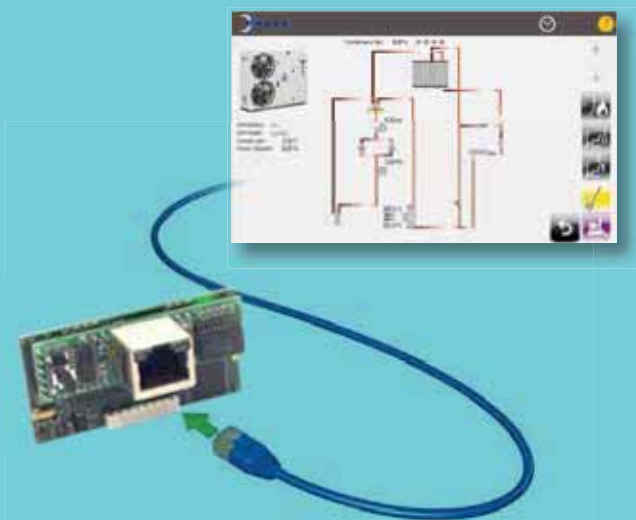

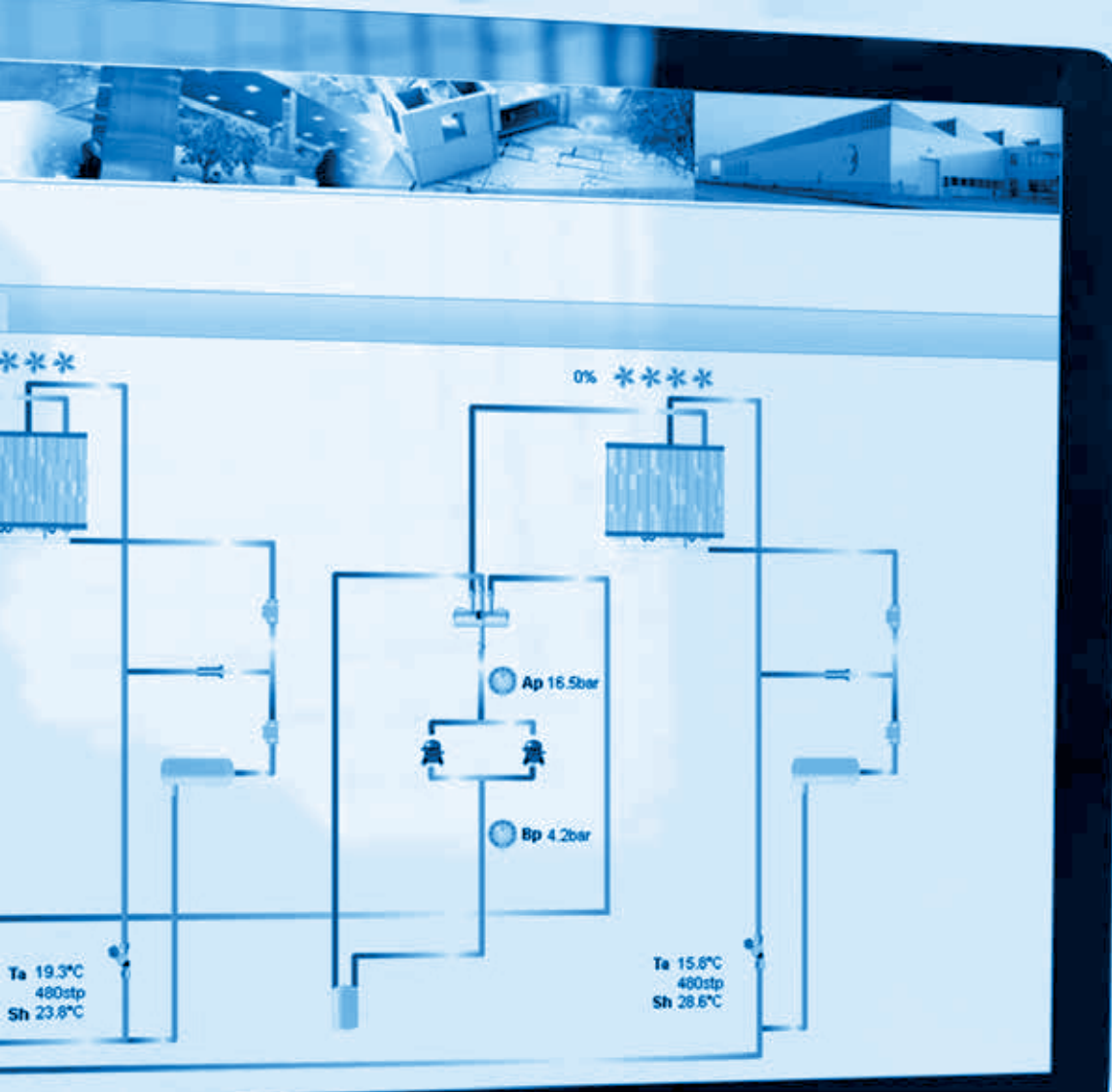

Web Server for Ethernet

RHOSS WEB SERVER

MANAGEMENT VIA WEB BROWSER

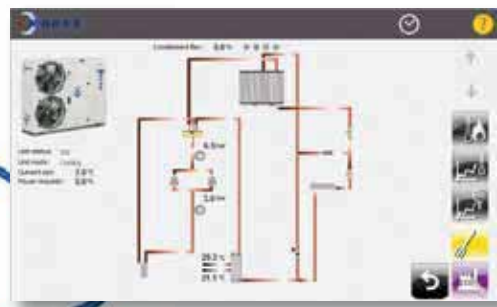

Single unit

WEB SERVER MAIN FEATURES

- Web page with unit status and detailed tabs displaying:
- synoptic diagram of the main components
 - main variable trend graph
 - option to edit main parameters (on/off, mode, set)
 - alarm status and reset

MAIN COMPONENTS

KWEBU1:
Web Server board for Ethernet
with user graphic interface



NIBE GROUP MEMBER



RhossOfficial



RhossOfficialChannel



Rhoss

RHOSS S.P.A.
Via Oltre Ferrovia, 32 - 33033 Codroipo (UD) - Italy
tel. +39 0432 911611 - rhoss@rhoss.it
www.rhoss.it - www.rhoss.com

Italy Sales Departments:
Codroipo (UD)
33033 Via Oltre Ferrovia, 32
tel. +39 0432 911611

Nova Milanese (MB)
20834 Via Venezia, 2 - p. 2
tel. +39 039 6898394

RHOSS France
Bat. Cap Ouest - 19 Chemin de la Plaine - 69390 Vourles - France
tél. +33 (0)4 81 65 14 06 - exportsales@rhoss.it
www.rhoss.com

RHOSS Deutschland GmbH
Hölzlestraße 23, D-72336 Balingen, OT Engstlatt - Germany
tel. +49 (0)7433 260270 - info@rhoss.de
www.rhoss.com

RHOSS Ibérica Climatización, S.L.
Frederic Mompou, 3 Pta. 6ª Dpcho. B 1 - 08960 Sant Just Desvern – Barcelona
tel. +34 691 498 827 - rhossiberica@rhossiberica.com
www.rhoss.com