

## 4.7 Super Link LON Gateway

### 4.7.1 SC-LIF-E

#### 1. SYSTEM ARCHITECTURE

##### 1. SYSTEM DIAGRAM

The system configuration diagram of LonWorks interface is shown below. Outdoor units are omitted to make the diagram easy.

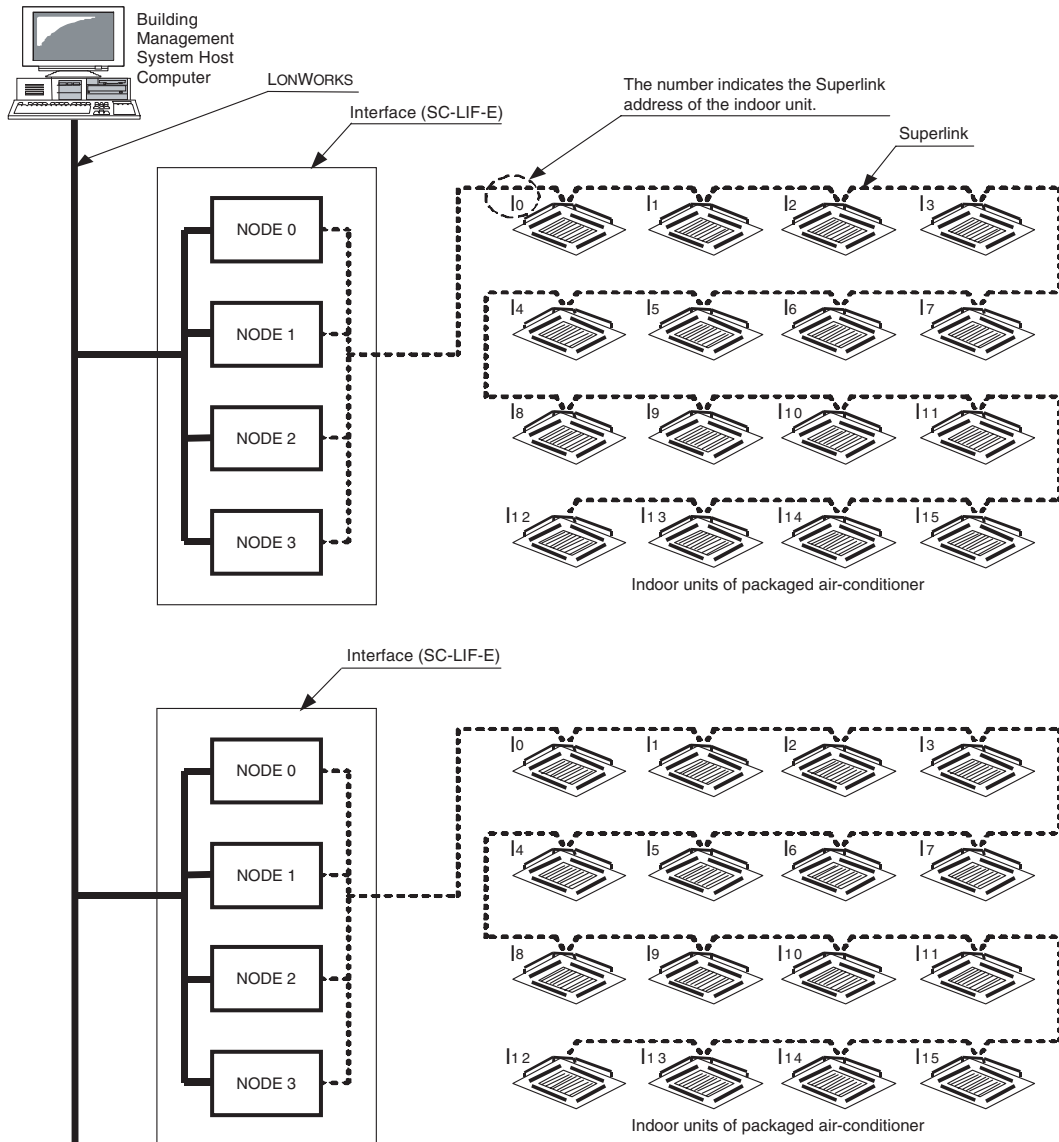

- Note 1) The "NODE" is a printed circuit board for LonWorks communication. This interface has four NODEs in the casing box. The Interface has one terminal block for the LonWorks line, and the four NODEs are connected to the LonWorks line inside the casing box.
- 2) Four indoor units of packaged air-conditioners can be assigned to each NODE.
- 3) One interface alone can be connected to each Superlink system. Accordingly, two or more Superlink systems can not be connected as one system.
- 4) Each interface can control and monitor maximum 16 indoor units of the Superlink address No. 0 to No.15.
- 5) If Superlink adapter is used, a group of indoor units can be regarded as one unit and can be controlled. This makes it possible to expand the number of the indoor units managed by the interface to 16 or more. For details, refer to the separate document "Appendix A Group connection with Superlink adapter (SC-AD-L)" (Document No. IST021228).

2. Assignment illustration of NODEs and indoor units

The Superlink addresses of the indoor units are assigned to each NODE in the Interface as explained below.

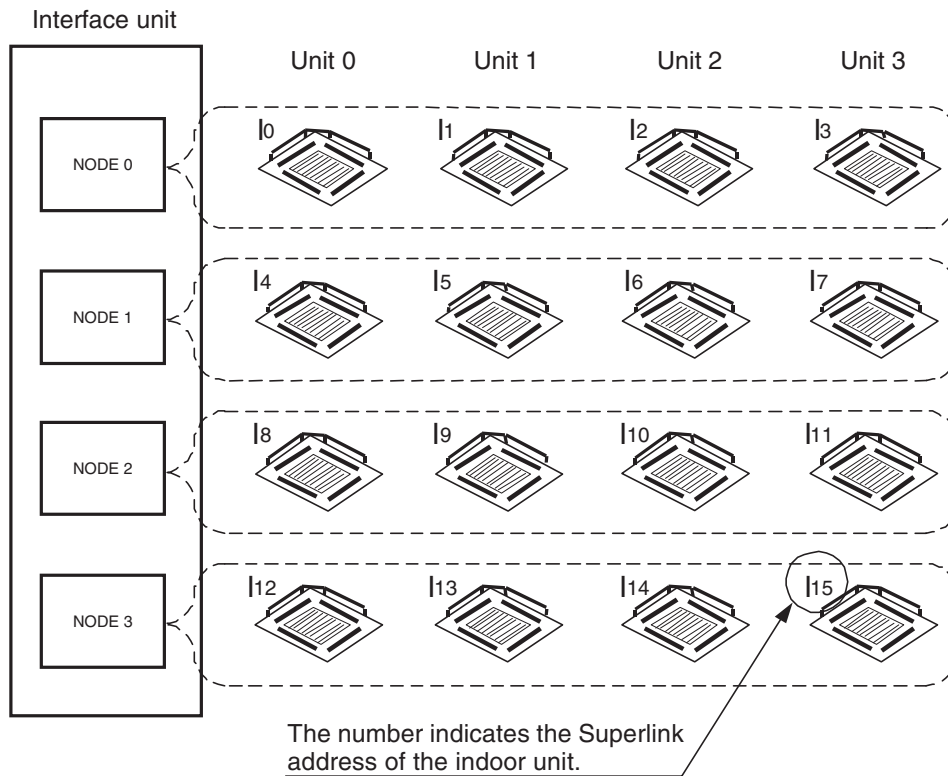

The Superlink addresses of the indoor units controlled by each NODE are previously fixed to each NODE, and are assigned as shown in the following table.

	1st	2nd	3rd	4th
<u>NODE No.</u>	<u>Unit 0</u>	<u>Unit 1</u>	<u>Unit 2</u>	<u>Unit 3</u>
NODE 0:	I <sub>0</sub>	I <sub>1</sub>	I <sub>2</sub>	I <sub>3</sub>
NODE 1:	I <sub>4</sub>	I <sub>5</sub>	I <sub>6</sub>	I <sub>7</sub>
NODE 2:	I <sub>8</sub>	I <sub>9</sub>	I <sub>10</sub>	I <sub>11</sub>
NODE 3:	I <sub>12</sub>	I <sub>13</sub>	I <sub>14</sub>	I <sub>15</sub>

The four indoor units assigned to each NODE are sequentially defined as the "Unit 0", "Unit 1", "Unit 2" and "Unit 3". For example, if the indoor unit of I<sub>6</sub> is the objective for the control, the network variables of the "Unit 2" of the NODE 1 have to be bound, since I<sub>6</sub> is the 3rd unit of the NODE 1.

The suffix number of the network variable name described in the Network Variable Assignment Table later in this document is the "Unit" number. For example, the On/Off command of I<sub>6</sub> corresponds to the network variable of nviOnOff\_2 in NODE 1.

- Assignment example of NODE, and indoor unit addresses  
 In case that the indoor unit addresses 0, 1, 2, 4, 5, 7, 8, 10, 11 and 12 are to be assigned.

**Proper assignment :**

If address of the indoor unit is not sequential, it is regarded as blank.

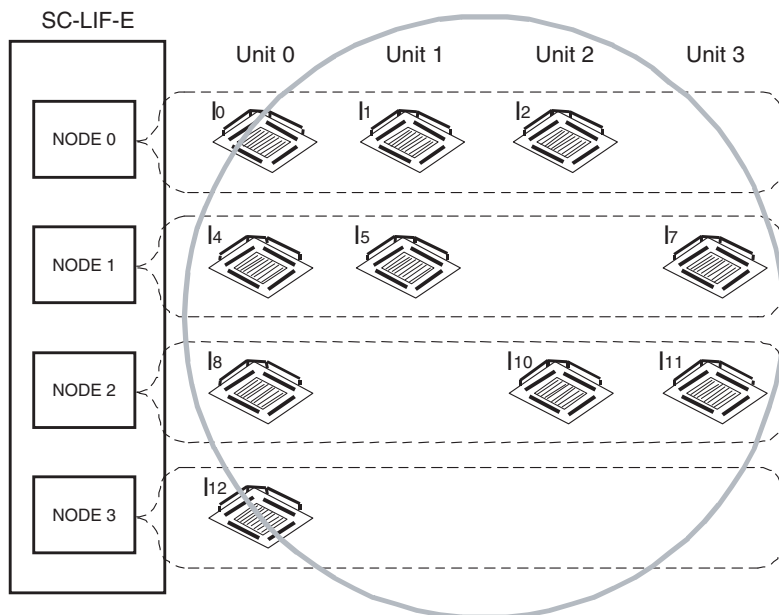

**Wrong assignment**

The indoor unit address assigned by each NODE is fixed, even if any indoor unit is not present.

As shown below for example, the indoor unit I4 can not be assigned as "Unit 3" of the NODE0 even if the indoor unit address I3 is not present.

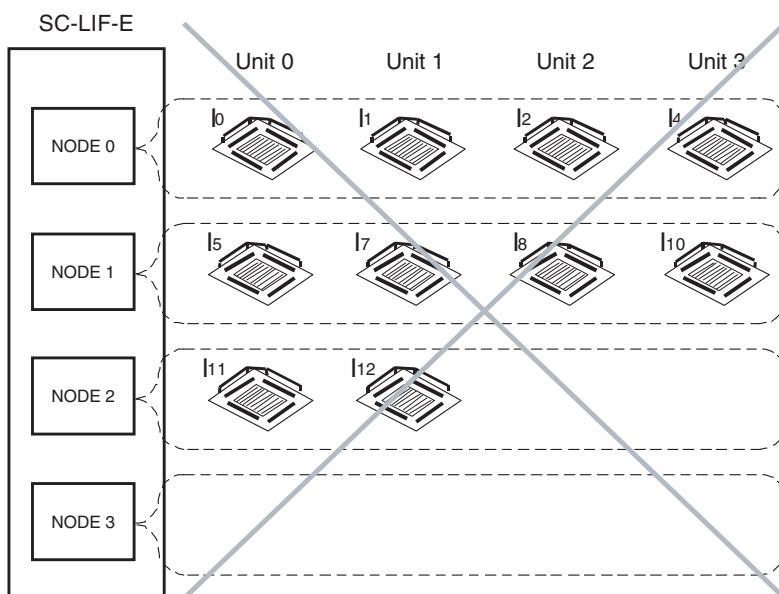

## 4. Notes for assignment of NODEs, and indoor unit addresses

## 1. Remote controller group connection

If several indoor units are connected to one remote controller, the state of each indoor unit might become unmatched if each indoor unit is individually controlled with the host computer via the LonWorks Interface. In this case, the status display might be unmatched between the remote controller and the host computer. This is because one of the indoor units is displayed on the remote controller with priority.

To prevent this, the host computer should send the input network variable of the same content for the group of indoor units connected to one remote controller. For example, in case of the On / Off command, prevent such a case as "On" is sent to one indoor unit and "Off" is sent to another indoor unit.

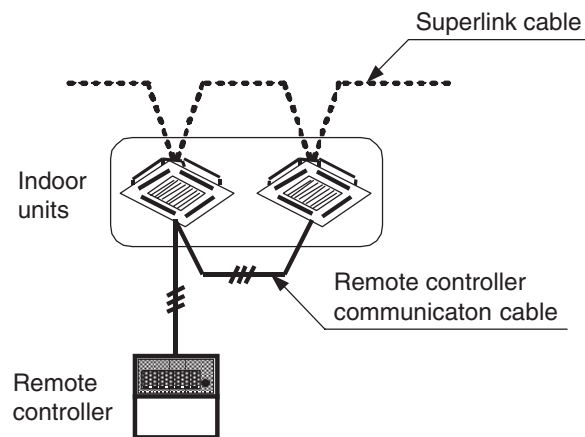

## 2. Connection without remote controller

It is strongly recommended to use the remote controller to the indoor unit, even if all controls and monitors are done from the LonWorks interface. The following functions by the remote controller cannot be supported by the LonWorks interface if the remote controllers are not connected to the indoor units.

## (1) The content (error code) of an error is not displayed anywhere.

Though the LonWorks interface has the "Failure status" monitoring function to inform that the air conditioner is abnormally stopped, but it does not inform the error code. The error code is informed on the remote controller. Accordingly, the error code is not displayed anywhere if the remote controller is not connected.

## (2) The operation of the swing louver and the automatic elevation of the filter become impossible.

Since the LonWorks interface is not provided with operation functions of the swing louvers and automatic elevation of the air filter, these functions can not be used unless the remote controller is connected.

## (3) The power failure recovering function is eliminated.

LonWorks interface does not provide with the power failure recovering function. In a case of the power failure, the operation modes and settings of the packaged air-conditioner is to be recovered from the remote controller if the "Power Failure Recovering Switch" inside the remote controller is set to ON. Accordingly, any setting of the packaged air-conditioners is not recovered unless the remote controller is connected.

## 2. Equipment specifications

	Item	Specifications	Remarks
Construction	Casing box dimensions	250(H) x 100(W) x 180(D)	
	Weight	Approx. 2.6kg	
	Case material	Zinc-plated steel plate (t1.2)	
	Case painting	Color:cream	
	Installation method	Fixed with the mouting brackets	
Power supply	Power supply voltage	Single-phase 100VAC-15% to 200VAC+10% (50/60Hz)	The main switches and power LED are arranged on the front.
	Wiring connection	Terminal block	Terminal No. "L", "N"
	Power consumption	Max. 5W	
Environmental condition	Ambient temperature for operation	0°C to 40°C	
	Ambient humidity for operation	85%RH or less (without dewing)	
Communication	LONWORKS® network		
	Wiring connection	Terminal block	Terminal No. "1", "2"
	Transceiver	FTT-10A	Free topology (78kbps)
	Service pins	Arranged on the front panel One per NODE, 4 pins as a total	Switch and LED unitized type
	Superlink network		
	Wiring connection	Terminal block	Terminal No. "A", "B"
	Number of connectable units	Max. 16 indoor units	

### 3. Function specifications

#### [Control function]

- |                               |   |
|-------------------------------|---|
| 1. On / Off command           | The Run / Stop is applied to each indoor unit. It is the same function as the On / Off command from the remote controller connected to the indoor unit.   |
| 2. Operation mode setting     | The operation modes (Automatic, Cooling, Fan and Heating) are set for each indoor.  |
| 3. Temperature setting        | The temperature setting of each indoor unit is set. The value is set at the intervals of 1°C in the range of 18°C to 30°C.                                |
| 4. Remote controller prohibit | Whether the operation by the remote controller is allowed or prohibited is set. The function allows/prohibits all the functions of the remote controller. |
| 5. Filter sign reset command  | After the intake air filter sign LED of the remote controller has become lit (it is recommendation to clean the filter), this function will turn it off.  |
| 6. System stop command        | The four indoor units controlled by one NODE are all immediately stopped, and thereafter the operation from the remote controller is prohibited.          |

#### [Monitor function]

- |                           |  |
|---------------------------|--|
| 1. On / Off status        | The Run / Stop status of each indoor unit is informed.   |
| 2. Operation mode status  | The operation mode of each indoor unit is informed.  |
| 3. Temperature set status | Temperature setting of each indoor unit is informed.   |
| 4. Filter sign status     | The filter sign of the remote controller is informed. When the accumulated operation time is counted up to the limit time, the filter sign of the remote controller will be lit to recommend that the air filter shall be cleaned. |
| 5. Failure status         | Whether a trouble is present in the air conditioner is informed. The error code of the trouble is not informed by this LonWorks interface, but it is indicated on the remote controller.   |
| 6. Room temperature       | The intake sensor temperature of the indoor unit is indicated. The intake sensor temperature is sometimes called "the room temperature".   |
| 7. Thermo status          | Whether the refrigerant flows into the indoor unit or not is informed. This status corresponds to the thermostat status.   |
| 8. Communication status   | Whether the Interface can communicate with each indoor unit is informed. Normally, this status means the power on / off status of the indoor unit.   |
- \* Since each monitor function above is checked by LonWorks interface periodically every one minute, the information to the LonWorks is sometimes delayed maximum about one minute depending on communication timing.
- \* If the group connection is done with the Superlink adapter, information of the above monitor function is the content of the representative indoor unit in the group. For details, refer to Product Specification Appendix A "Group connection with Superlink adapter (SC-AD-L)".

## [Setting function]

1. Send Heartbeat  
It sets the interval time for sending the following output network variables. This function is invalidated at shipment.
  - On / Off status
  - Temperature set status
2. MinimumSendTime  
It sets the minimum time to send the following network variable. This function is invalidated at shipment.
  - Room temperature status
3. Delay Time  
It sets the delay time for the data sending when the power supply is turned on. This function is invalidated at shipment.
4. Receive Heartbeat  
If the following input network variable is not received for a certain time, the variable will be returned to the initial value. This function is invalidated at shipment.
  - Remote controller prohibit command

## [Object Request / Status function]

1. Object Request / Status  
It is used to check whether the NODE malfunction is present or not.  
If it is normal, the object status will be answered back to the object request from the host computer of the building management system.

## [Installation function]

1. Wink function  
When the wink command is received from the network control tool, the service LED of the receiving NODE flickers.
2. Service switch & LED  
The LED integrated switch is provided on the front panel. When the switch is pressed, Neuron ID of corresponding NODE is sent to LonWorks network. The status of the NODE can be checked with this LED status.

4. Connection wiring diagram

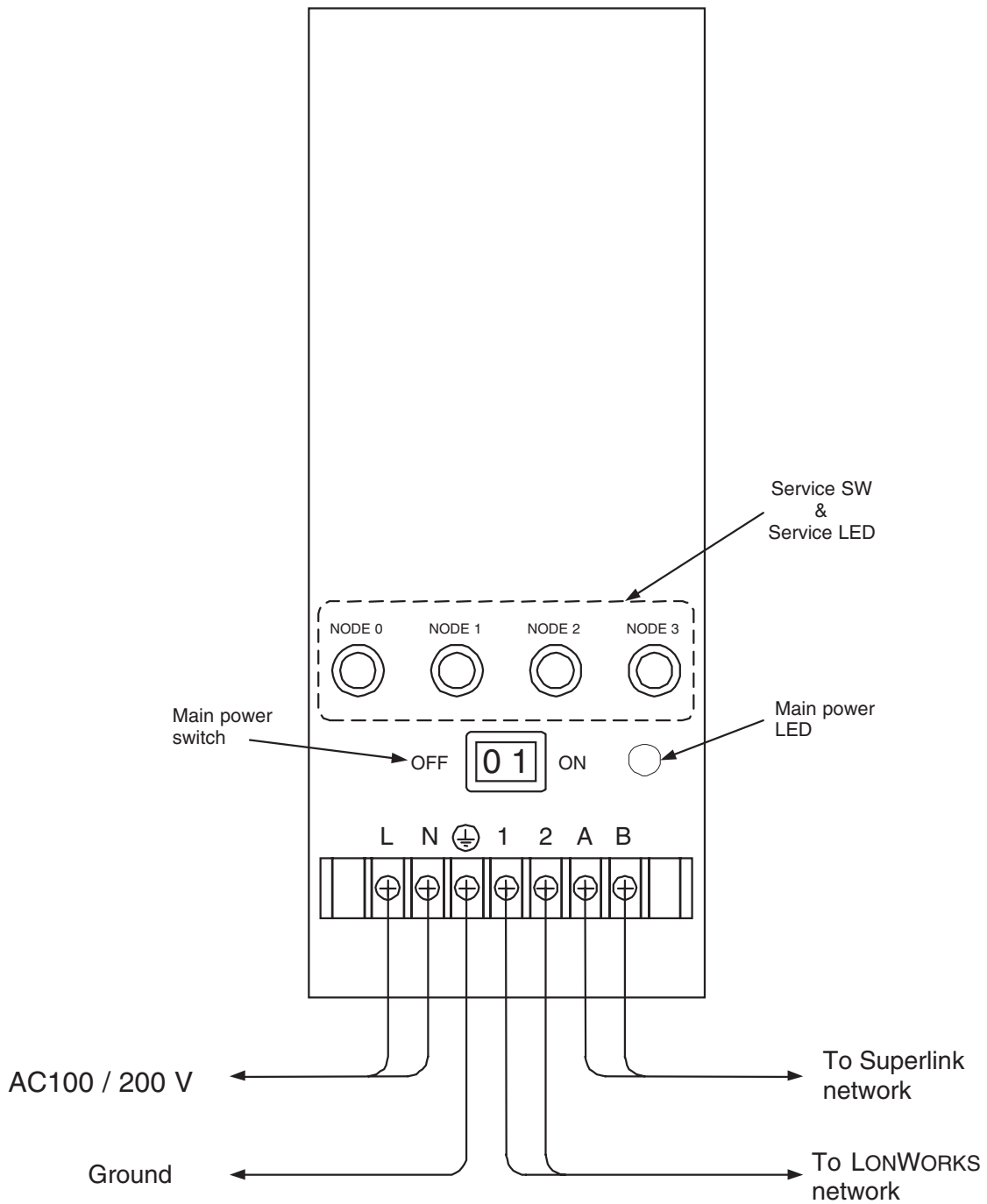



5. Outline drawing

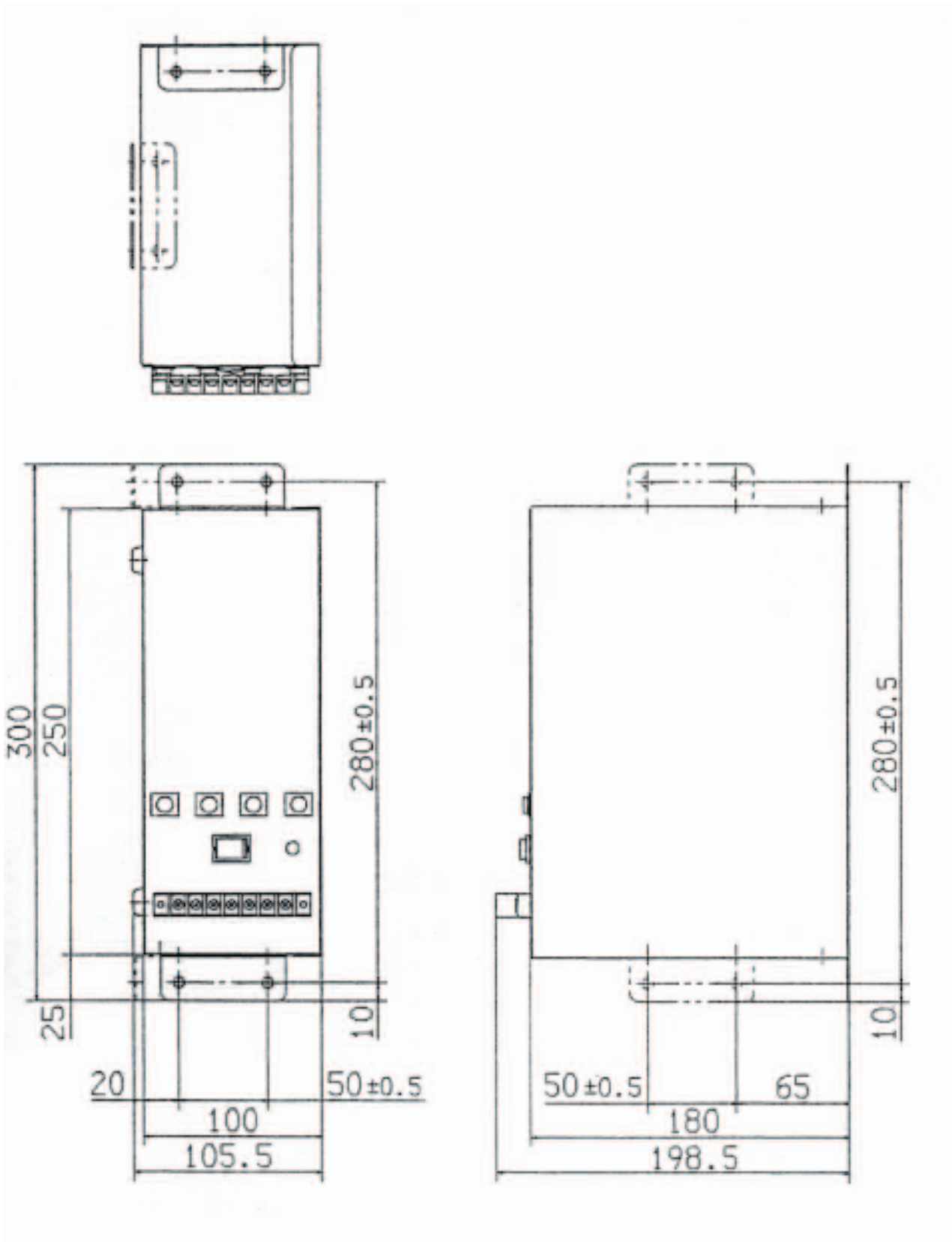

## 4.7.2 SC-LGW-A

### 1. INTRODUCTION

#### 1. SCOPE

This product specification is applied to the LON Gateway SC-LGW-A which connects the LON\*1 network with the MITSUBISHI HEAVY INDUSTRIES' "SUPERLINK" networks. This document describes the specifications of the product as for Nov. 27, 2004. Any contents of this document may be changed without prior notification.

\*1 LON is a widely used control network by Echelon Co. "LON" is Echelon's registered trade name.

#### 2. OUTLINE OF PRODUCT

- Number of SUPERLINK networks : 2 networks
- Number of indoor units : Max.48 × 2 networks = Max.96 indoor units  
(Max.32 × 2 networks = Max.64 indoor units in case that SLA-1/SLA-2A's are connected)
- Number of LON nodes : 1 node for this gateway
- Number of network variables : 1250 (implemented as 97 Functional Blocks)
- LON transceiver : FTT-10A

#### 3. LONMARK

This LON Gateway is not LONMARK approved product. There is no LONMARK Functional Profile for packaged air-conditioners.

#### 4. ENGINEERING WORK

"Engineering work" means technical service work such as dispatching engineers to the site, the address allocation planning work, configuration of this gateway, trial operation of the system and so on. These engineering works may be paid services.

#### 5. CUSTOMIZE WORK

This LON Gateway is a kind of ready-made product. Customization of the functions of this gateway cannot be supplied.

## 2. SYSTEM ARCHITECTURE

### 1. SYSTEM DIAGRAM

Fig. 5.5 shows a basic case of the system diagram of connection between the Building Management System host computer, the LON Gateway and the SUPERLINK control networks.

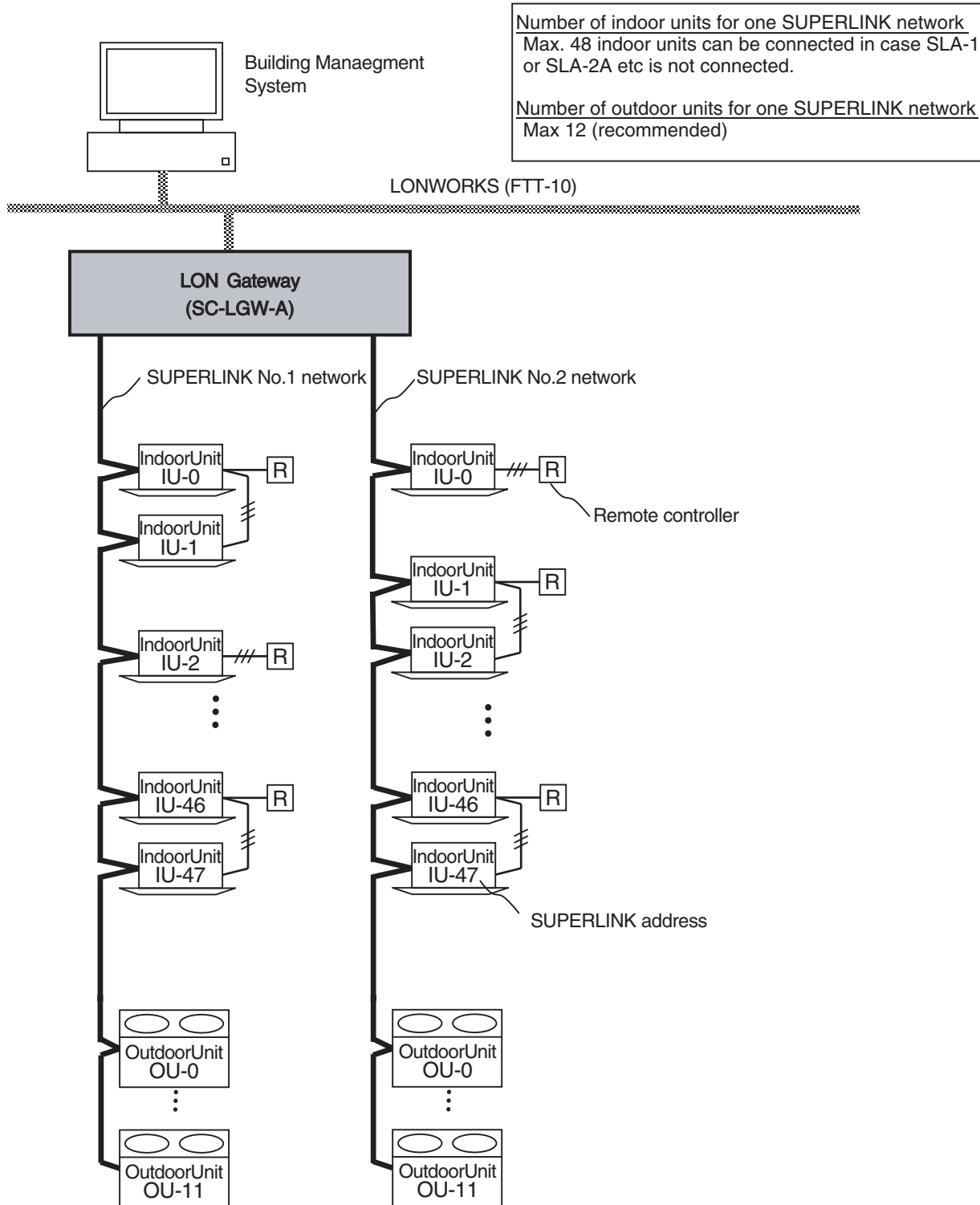

Fig. 5.5 System Diagram (Basic case)

Fig. 5.6 shows a case of the system diagram of connection between the Building Management System host computer, the LON Gateway, and the SUPERLINK control networks along with SUPERLINK option controllers SLA-1 or SLA-2A. The SC-AD-L adapter should be used for connection of MHI's single type packaged air-conditioner models.

Number of indoor units for one SUPERLINK network  
 Max. 32 indoor units can be connected in case SLA-1-E or SLA-2A-E is connected.

Number of outdoor units for one SUPERLINK network  
 Max 12 (recommended)

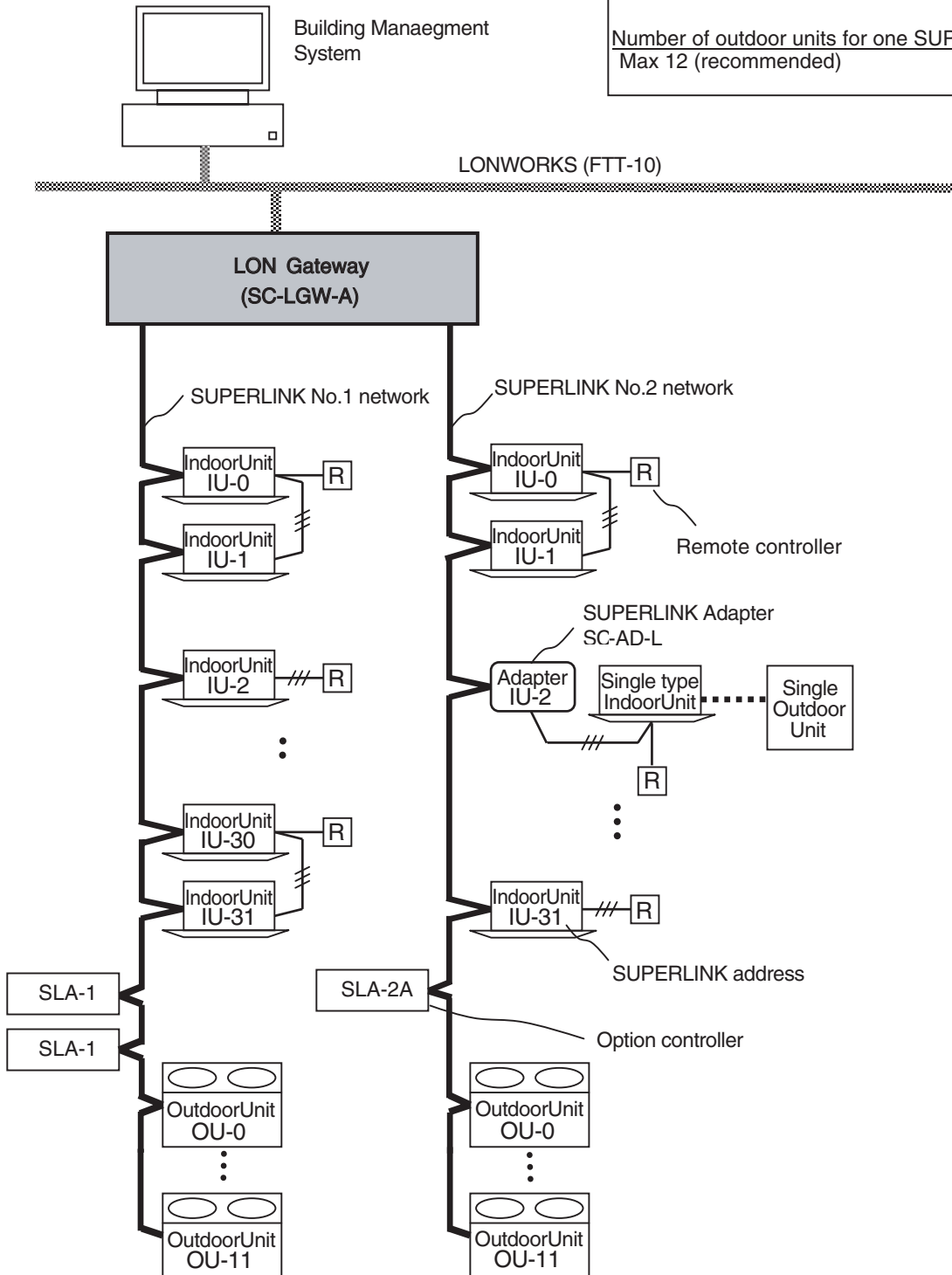

Fig. 5.6 System diagram (With SLA-1-E/SLA-2A-E)

## 2. AIR-CONDITIONER CONNECTION

## (1) Packaged Air-Conditioner Models

- MHI's Multi KX series
- MHI's Multi GHP series
- SC-AD-L adapter+Separate PAC series

When the SC-AD-Ls are used, some functions will become invalid. The detail explanation of the limitations for the SC-AD-L will appear in the later version of this document.

## (2) Max number of indoor units

The maximum number of indoor units connected is shown in the Table 5.4 depending on connection of the SUPERLINK option controller such as SLA-1-E or SLA-2A-E. The reason why the number of indoor units connectable is reduced in the case of option controller connection is for communication traffic limitation.

Table 5.4

	Without option controller	With option controller(*)
Number of SUPERLINK networks	2 networks	2 networks
Number of indoor units	Max. 48 units × 2 = Max. 96	Max. 32 units × 2 = Max. 64

## 3. LON COMMUNICATION

## (1) COMPATIBLE LON NETWORK

- Communication Protocol : LonTalk
- Transceiver Type : FTT-10A
- Transmission Speed : 78kbps

## (2) LON Node

This LON gateway has only one LON node. The node has 1250 network variables for 96 indoor units of air-conditioners. In other words, 13 network variables for every indoor units make 1250 network variables for 96 indoor units for this gateway.

### 3. FUNCTION OVERVIEW

#### 1. LON NETWORK MANAGEMENT FUNCTIONS

Since this LON gateway is not LONMARK approved products, some LON network management functions are not supported by this gateway.

Table 5.5 List of the LON Network Management Functions

Function	Support	Explanation
Service PIN	Yes	Broadcasts Neuron ID by pressing Service PIN on the case
Wink	No	No response when receiving Wink message
Object Request	No	No response when receiving Object Request message
Object Status	No	No response when receiving Object Request message
Send HeatBeat	Yes	For Only output network variables for air-con On/Off status
Receive HeatBeat	No	Cannot be configured
Minimum Send Time	No	Cannot be configured
Delay Time	No	Cannot be configured

#### 2. CONTROL & MONITOR FUNCTION OVERVIEW

The control and monitor functions mean categories of jobs from an air-conditioning system's point of view. The Table 5.6 shows the control and monitor functions of the SC-LGW-A Gateway.

Table 5.6 List of Control & Monitor Functions

	Function	Explanation
CONTROL	On/Off command	Send On / Off command to an indoor unit
	Mode command	Send Operation Mode command (Auto, Cooling, Heating, Fan) to an indoor unit.
	Setpoint command	Send Temperature Setpoint command to an indoor unit. The range is from 18 to 30 degrees Celsius.
	Fanspeed command	Send Fanspeed select command (Hi, Me, Lo) to an indoor unit.
	Filter Sign Reset command	Send Reset command for Filter Sign to the remote controller of an indoor unit.
	Remote controller Lock / Unlock command	Send the remote controller operation Lock or Unlock command to an indoor unit.
	System Stop command	Send Forced Off commands to all indoor units and set all remocons Lock mode simultaneously.
MONITOR	On/Off status	Monitor On / Off status of an indoor unit.
	Mode status	Monitor Operation Mode status (Auto, Cooling, Heating, Fan) of an indoor unit.
	Setpoint status	Monitor Temperature Setpoint status of an indoor unit.
	Fan Speed status	Monitor Fanspeed select status of an indoor unit.
	Room Temperature Status	Monitor Inlet air temperature sensor data of an indoor unit.
	Failure status	Monitor Failure status and Error Code of an indoor unit.
	Filter Sign status	Monitor Filter Sign status of an indoor unit.
	System Stop status	Monitor All air-conditioner Forced Off status.

#### 4.HARDWARE SPECIFICATIONS

- (1) Power Supply
  - AC single phase 100V - 240V +10%, -15% 50/60Hz
  
- (2) Operation Temperature
  - Ambient Temperature : 0 to 40 degrees Celsius
  - Relative Humidity : Max 85 %RH (without dewing)
  
- (3) Storage Temperature
  - Ambient Temperature : -10 to 50 degrees Celsius
  - Relative Humidity : Max 85 %RH (After 48 hours from out of storage, dewing should not exists)
  
- (4) Power Blackout Compensation
  - This gateway does not have a battery circuit for power blackout recovery.
  - If blackout or manual power-off occurs for more than 30 msec, the monitoring data and the setting of each indoor unit, such as the operation mode or set point temperature, may disappear.
  - This gateway does not store and recover the On/Off control settings. However, depending on the setting of the remocon, indoor units will restart when the power supplies to the whole air-conditioner system resume to normal state.
  
- (3) Appearance
  - Outline drawing : Fig 5.6 on the following page
  - Outline dimensions : 260 (W) × 200(H) × 79 (D) mm
  - Color : Cream

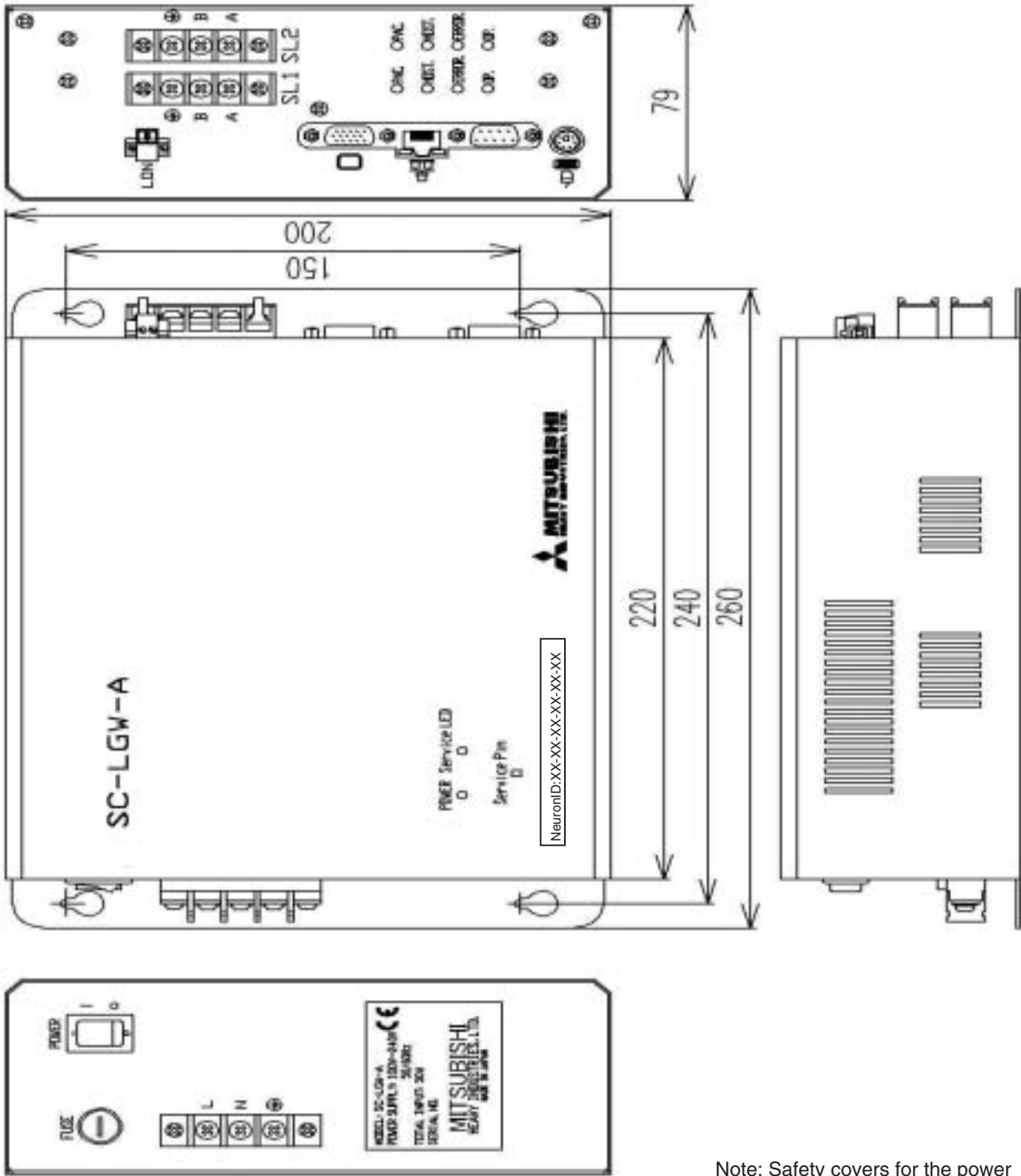

Note: Safety covers for the power terminals are not shown

Fig. 5.7 Outline Drawing of the SC-LGW-A



**5.INSTALLATION**

1. INSTALLATION CONDITIONS

This gateway SC-LGW-A has a terminal block for the AC power supply on the outside surface of the casing.

For avoiding electrical shock injury, the SC-LGW-A should be installed inside a cabinet with a lock

The direction of placement of this Gateway when installation should be such a way that the front panel is vertical and the lettering of the front panel is right direction to enable air-cooling.

The recommended service space surrounding this Gateway is as follows;

- Upper clearance : Minimum 30 mm
- Lower clearance : Minimum 30 mm
- Right side clearance : Minimum 50 mm (more than 100 mm is recommended)
- Left side clearance : Minimum 50 mm (more than 200 mm is recommended)

The side clearance is for wiring workspace.

2. WIRING

The Fig 5.8 shows the wiring of this Gateway. After wiring to the LON Gateway, the terminal covers, which are included in this Gateway's product package, should be installed by screws as shown in the Fig 5.7. After wiring work finished, fix the terminal covers securely by the screws

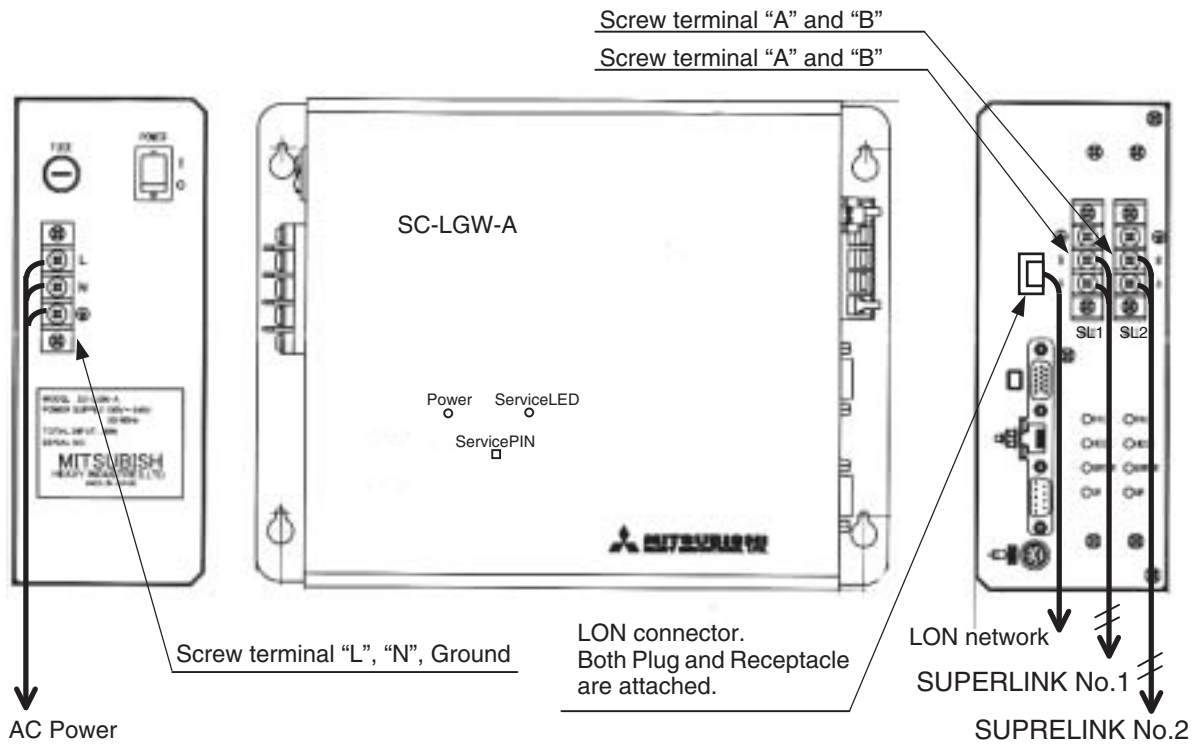

**Fig. 5.8 SC-LGW-A Wiring**

## 3. LON CABLE

This gateway supports the LON FTT-10A twisted-pair transmission line which is the most popular network line type of LONWORKS. Follow the Building Management System vendor's the LON cable selection.

This gateway has both plug and receptacle for the LON connector on the side panel. Connect the end of the twisted-pair cable to the connector plug's screw.

## 4. SUPERLINK CABLE

This Gateway supports the SUPERLINK control network. The recommended specifications of the cable for the SUPERLINK are shown as follows;

- (1) Size of cable : 0.75 to 2.0 square mm
- (2) Max length of wiring : 1000m/channel (loop wiring is not allowed)
- (3) Cable materials :

Twisted Vinyl Cabtyre Cable	VCTF	2 core	0.75 to 2.0 square mm
Twisted Vinyl Cabtyre Cable	VCT	2 core	0.75 to 2.0 square mm
Twisted Vinyl Cable for Control	CVV	2 core	0.75 to 2.0 square mm

- (4) For prevention of electromagnetic noise malfunctions, parallel wiring with the power line should be avoided.

## 4.8 Super Link BACnet Gateway SC-BGW-A

### 1. INTRODUCTION

#### 1. SCOPE

This preliminary product specification is applied to the communication unit SC-BGW-A that connects a Building Management System network and MITSUBISHI HEAVY INDUSTRIES' "SUPERLINK" networks by the "BACnet"\*<sup>1</sup> communication protocol. This document describes the overview specifications of the product as for April 22, 2004. Any contents of this document may be changed without prior notification.

\*<sup>1</sup> BACnet : Building Automation and Control networks

#### 2. STANDARDS/GUIDELINES

This product is designed as conforming to the following standard and guideline.

(1) BACnet/IP standard 1995 version

"ANSI/ASHRAE Standard 135-1995 : Data Communication Protocol for Building Automation and Control Networks"

(2) JRAIA Interface Committee Guideline

"BACnet Implementation Guideline for Packaged Air-conditioners" Ver.1.0 Feb.5, 2004 issued by the Interface Committee of the Japanese Refrigeration and Air-conditioning Industry Association.

(3) CE Markings

"EMC Directive, 89/336/EEC, 92/31/EEC and 93/68/EEC"

#### 3. ENGINEERING WORK

"Engineering work" means technical service work such as dispatching engineers to the site, the address allocation planning work, configuration of this Gateway, trial operation of the system and so on. These engineering works may be paid services.

#### 4. CUSTOMIZE WORK

This Gateway is a kind of ready-made product. Customization of the functions of this Gateway will not be accepted.

2. SYSTEM ARCHITECTURE

1. SYSTEM DIAGRAM

Fig. 5.9 shows a basic case of the system diagram of connection between the building management system host computer, the SC-BGW-A BACnet Gateway and the SUPERLINK control networks.

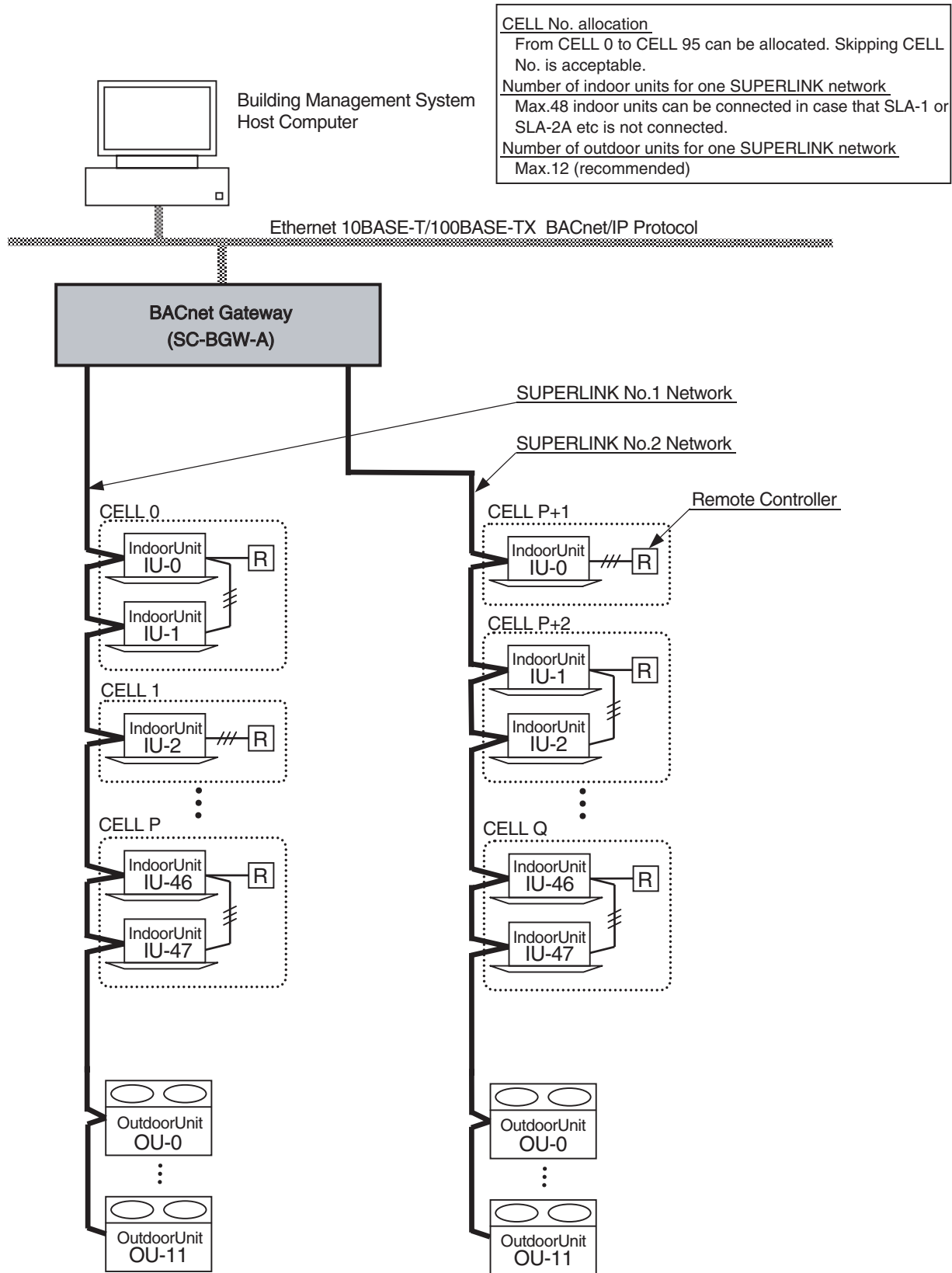
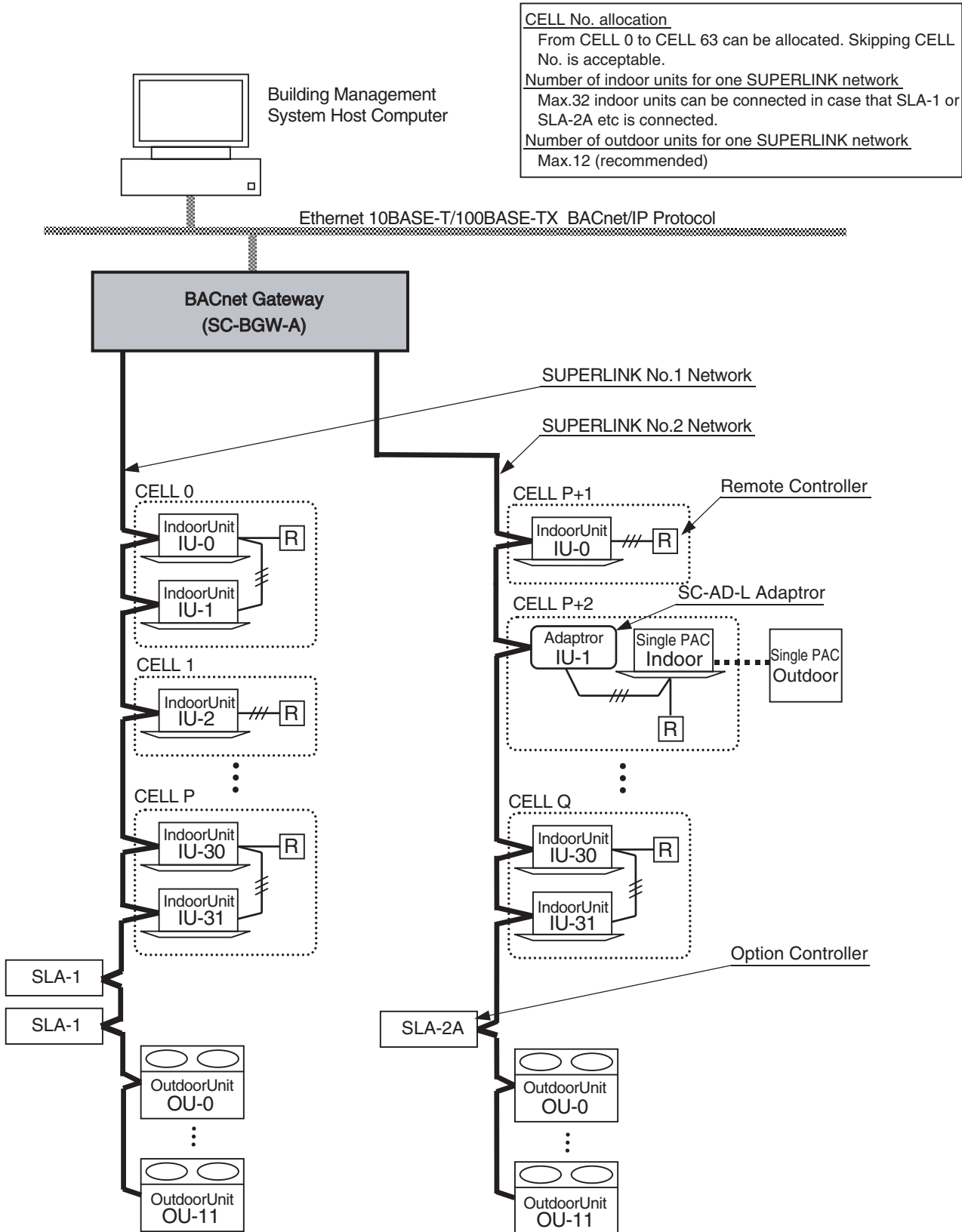

Fig. 5.9 System Diagram (Basic case)

Fig. 5.10 shows a case of the system diagram of connection between the building management system host computer, the SC-BGW-A BACnet gateway, and the SUPERLINK control networks along with SUPERLINK option controllers such as SLA-1 or SLA-2A. The SC-AD-L adaptor should be used for connection of MHI's single packaged air-conditioners models.



**Fig. 5.10 System Diagram (Option controller connected)**

2. BMS CONNECTION

(1) Lower Layer of the BACnet Protocol

This gateway is to be connected to the Building Management System (BMS) network by the BACnet/IP lower layer communication protocol that works over an IP network.

- Lower layer protocol : BACnet/IP of the BACnet standard "ANSI/ASHRAE Standard 135-1995"
- Physical layer : Ethernet 10BASE-T or 100BASE-TX (Automatic selection)

(2) Communication connection specifications

To be written.

3. AIR-CONDITIONER CONNECTION

(1) Packaged Air-Conditioner Models

- MHI's Multi KX series
- MHI's Multi GHP series
- SC-AD-L adapter + Separate PAC series

When the SC-AD-Ls are used, some functions will become invalid. The detail explanation of the limitations for the SC-AD-L will appear in the later version of this document.

(2) "AIR-CON CELL"

A new concept of the "Air-con CELL" is introduced in this gateway system. An Air-con CELL is defined as a logical group of indoor units for control & monitor of the air-conditioners. An Air-con CELL consists one indoor unit or more than one indoor units connected by one remote controller.

In the Fig. 5.8, an Air-con CELL is indicated by a surrounding dashed line. The indoor units of the CELL should be on the same SUPERLINK network. But the CELL identification numbers can be allocated over the SUPERLINK networks as shown in Table 2.2.

Issuing a control command to a CELL is equal to issuing the control command to every indoor unit of the CELL. Therefore, operation of each indoor unit is identical for every indoor unit within the CELL. It is possible to control and monitor each individual indoor unit by defining a CELL equals to an indoor unit. All indoor units in the same CELL must be connected by the same remote controller, that is remocon group connection.

The CELL grouping definition is common to all the functions of this gateway. The CELL definition is provided by the PAC information file. The information file must be set before the test operation of this gateway.

This PAC information file is memorized by the non-volatile memory of this gateway once it is uploaded.

(3) Max number of indoor units

The maximum number of indoor units connected is shown in the Table 2.2 depending on connection of the SUPERLINK option controller such as SLA-1 or SLA-2A. The reason why the number of indoor units connectable is reduced in the case of option controller connection is for communication traffic limitation.

	Without option controller	With option controller(*)
Number of SUPERLINK networks	2 networks	2 networks
Number of indoor units	Max48 units × 2 = Max 96	Max32unts × 2 = Max 64
Number of CELLS	Max48 CELLS × 2 = Max 96	Max32 CELLS × 2 = Max 64
Range of CELL number	CELL 0 to CELL 95	CELL 0 to CELL 63

(\*) Option controllers should be max. 2 of SLA-1 or only one of SLA-2A for one SUPERLINK network.

### 3.FUNCTION OVERVIEW

#### 1. COMMUNICATION FUNCTIONS

Table 5.7 shows the list of the functions of this BACnet gateway from a view point of BACnet communication between a building management system host computer and this gateway.

Table 5.7 Communication Function List

Function	Description
Reset start	Broadcasts BACnet "I_Am" message at the reset start.
Alive check	Broadcasts BACnet "I_Am" message every 1 minute continuously.
Write service from host	Accepts BACnet Write Services from the host computer.
Read service from host	Responds to BACnet Read Service form the host computer.
Change of Value Report	Broadcasts Change of Value of the packaged air-conditioners.
Alarm report	Broadcasts Alarm report of the packaged air-conditioners

#### 2. CONTROL&MONITOR FUNCTIONS

Table 5.8 shows the list of the functions of this BACnet gateway from a view point of control & monitor of the packaged air-conditioners. An "Air-con CELL" is a logical group of indoor units for one remote controller as defined in the section 2.2 in this document.

Table 5.8 Control & Monitor Functions List

	Function	Description
CONTROL	On/Off command	Sends On/Off command to an Air-con CELL through the SUPERLINK.
	Mode command	Sends Mode command (Cool, Heat, Fan, Auto, Dry) to an Air-con CELL through the SUPERLINK.
	Fan speed command	Sends Fan Speed command (Hi, Me, Lo) to an Air-con CELL through the SUPERLINK.
	Set Temp command	Sends Set Temperature (18 - 30 deg C) to an Air-con CELL through the SUPERLINK.
	Filter Sign Reset command	Sends Filter Sign Rest command to an Air-con CELL through the SUPERLINK.
	Remocon Lock command (All button)	Sends Remocon Lock command to an Air-con CELL through the SUPERLINK. All the functions will be locked/unlocked simultaneously.
	System Stop command	Sends Off and Remocon Lock commands to all Air-con CELLS simultaneously.
MONITOR	On/Off status	Reports On/Off status of an Air-con CELL to the host computer.
	Alarm status	Reports occurrence of failure stop of an Air-con CELL to the host computer.
	Error Code status	Reports failure stop Error Code of an Air-con CELL to the host computer.
	Mode status	Reports Mode status (Cool, Heat, Fan, Auto, Dry) of an Air-con CELL to the host computer.
	Fan Speed status	Reports Fan Speed setting status of an Air-con CELL to the host computer.
	Room Temp status	Reports Room Temperature sensor data of an Air-con CELL to the host computer.
	Filter Sign status	Reports Filter Sign status of an Air-con CELL to the host computer.
	Communication status	Reports SUPERLINK communication status of an Air-con CELL to the host computer.

#### 4.HARDWARE SPECIFICATIONS

- (1) Power Supply
  - AC single phase 100V - 240V +10%, -15% 50/60Hz
  
- (2) Operation Temperature
  - Ambient Temperature : 0 to 40 degrees Celsius
  - Relative Humidity : Max 85% RH (without dewing)
  
- (3) Storage Temperature
  - Ambient Temperature : -10 to 50 degrees Celsius
  - Relative Humidity : Max 85% RH (After 48 hours from out of storage, dewing should not exists)
  
- (4) Power Blackout Compensation
  - This gateway does not have a battery circuit for power blackout compensation.
  - If blackout or manual power off occurs for more than 30 msec, the monitoring data and the setting of each CELL (indoor unit), such as the operation mode or set point temperature, may disappear.
  - This gateway periodically writes the monitoring data of the CELLS to the non-volatile memory at every 24 hours. If the power supply is cut off, at the worst case, the monitoring data of 24 hours before that time will be stored. The stored settings are automatically recovered when this gateway is restarted.
  - This gateway does not store and recover the On/Off control settings. However, depending the setting of the remote controller, indoor units will restart when the power supply to the whole air-conditioner system resume to normal state.
  
- (3) Appearance
  - Outline drawing : Fig 5.11 on the following page
  - Outline dimensions : 260(W) × 200(H) × 79(D) mm
  - Color : Blue





# 5. Operation Instructions

## 5.1 Center Console SLA-1-E

### Component description and function

Operation / Check display lamp  
 Corresponding with the individual operation / stop switch and displaying the following content:  
 In operation: green light on  
 Stop or not connected: off  
 Abnormality: red light on

Individual operation / stop switch  
 A switch controlling only the operation / stop of designated units.  
 (16 in total)

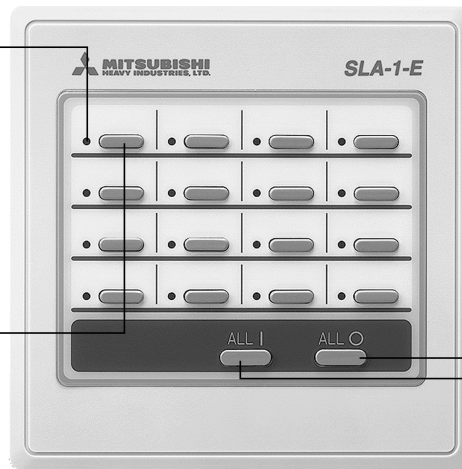

Simultaneous stop switch  
 A switch for simultaneous stop of all connected units.

Simultaneous operation switch  
 A switch for simultaneous operation of all connected units.

### Requirements

- Please make a note of the connected units on the attached switch display label, which should be placed above the switch.

### About installation

- Please do not install the equipment at places where interference exists.
- Please do not install the equipment at places with high humidity or vibration.
- Please do not install the equipment at places under direct sunshine or adjacent to heat sources.

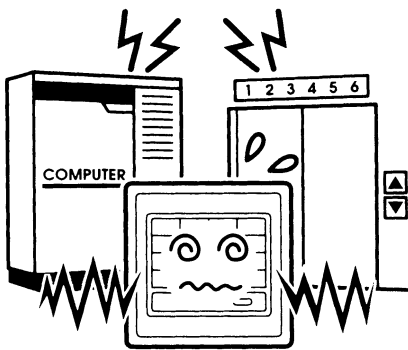

Installation beside computers, automatic doors, elevators or machines generating interference may result in mis-operation.

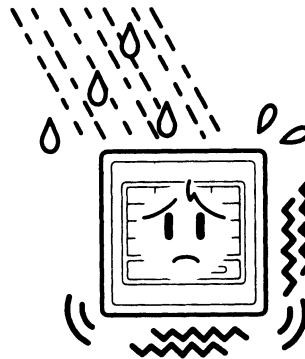

Installation at places with high humidity or vibration or water splash may lead to failures.

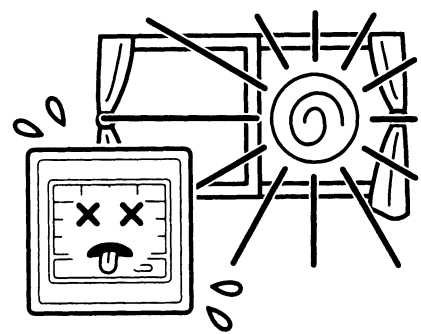

Installations at places under direct sunshine or adjacent to heat sources may lead to failures.

### Simultaneous operation method

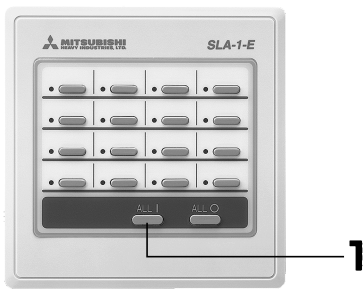

**1 Press the simultaneous operation switch**

All connected units start to run.

The operation / check display lamp indicates the following content:

- In operation: green light on
- Stop or not connected: off
- Abnormality: red light on

**To stop, press the simultaneous stop switch**

All connected units stop running and the operation / check display lamp is off.

### Individual operation method

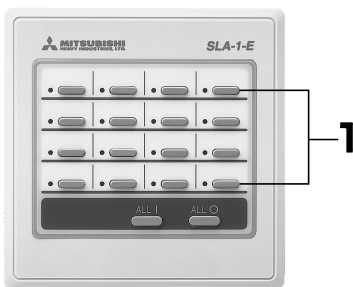

**1 Press the individual operation / stop switch**

If the switch connected to one unit is pressed, only such unit runs. The corresponding operation / check display lamp will become green light on.

**Stop Press the individual operation / stop switch during operation**

The air-conditioners stop running and the operation / check display lamp is off.

**Requirements**

- Please do not press the switches with sharp-pointed materials.

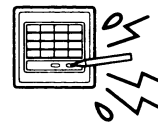

■ **About settings other than the operation/stop**

Please make operation mode setting, temperature setting and air rate setting through the standard remote controller (attached with the air-conditioner).

### When the operation / check display lamp is red light on



■ **An abnormality occurs to the air-conditioner.**

- In case of an abnormality, the air-conditioner stops operation and the corresponding display lamp turns red.

■ **Please contact the sales outlet where the unit was purchased and provide information including "type", "model and description", "failure characteristics", "failure sign" (indicated at the set temperature on the standard remote controller) of the faulty unit.**

- Press the individual operation / stop switch with the red light on, the display will be off.

## 5.2 Center Console SLA-2A-E

### Component description and function

Shown below is the state of the central controller after the cover is opened. All the explanations are recorded in the LCD.

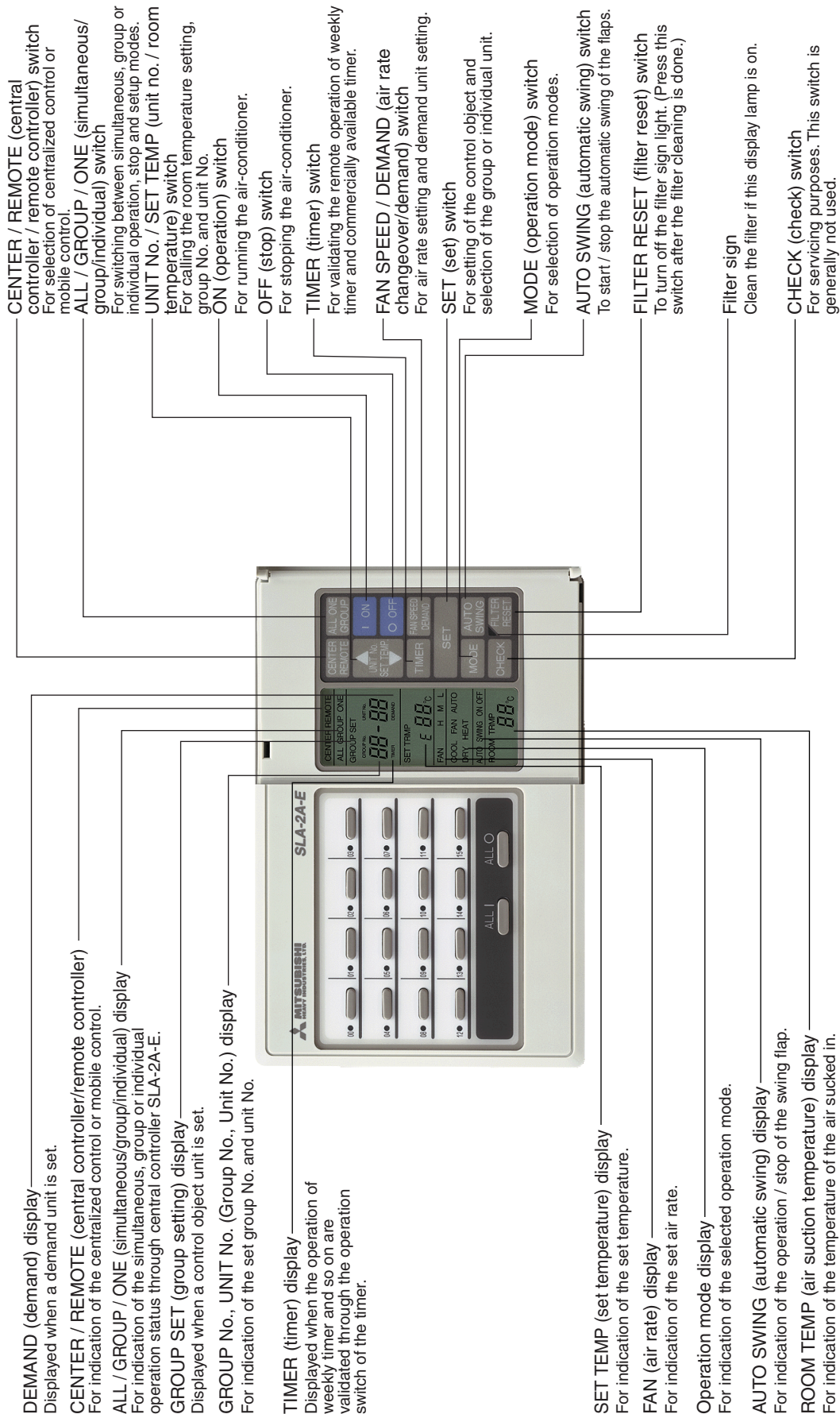

### Group setting method

**Requirement:** Please do not use SLA-2A-E to operate the units prior to group setting.

Please make group setting through SLA-2A-E in the following order:

- ① **Setting of the units other than the control objects.**
- ② **Setting of the control objects.**

① Units other than the object units controlled by central controller SLA-2A-E (or other central controllers).

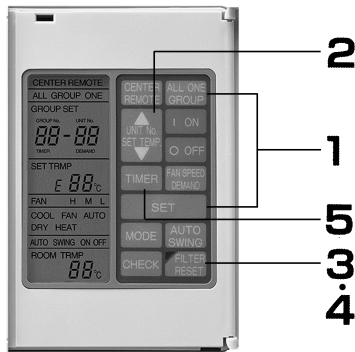

- 1 Press SET switch while ALL / GROUP / ONE (simultaneous/group/individual) switch is pressed.**  
The setup mode is validated and characters "00 – 00" flash.
- 2 Press UNIT No. / SET TEMP (unit no. / room temperature) switch to select units other than the control objects.**  
When the ▲ or ▼ buttons are pressed, the unit no. flashes and is switched at the same time.
- 3 Press the FILTER RESET (filter reset) switch**  
Unit No. display is on and the group No. display becomes "--".
- 4 Press the FILTER RESET (filter reset) switch again**  
"--" display is off and the unit No. display remains. The setting is done.
- 5 Press the TIMER (timer) switch**  
To return to the operation status display of the displayed unit No.

② Setting of units controlled by central controller SLA-2A-E and subject to the group control.  
00 ~15 can be set in SLA-2A-E with up to 16 groups. Logging on to any unit in each group is possible.

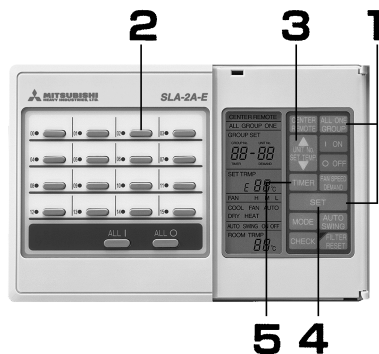

- 1 Press SET (set) switch and ALL / GROUP / ONE (simultaneous/group/individual) switch at the same time.**  
The setting mode is activated with characters "00 – 00" flashing.
- 2 Press the GROUP SET switch to select the group to be set.**  
The flashing display of GROUP No. turns into the selected No.
- 3 Press UNIT No. / SET TEMP (unit No. / room temperature) switch to select units to be set.**  
When the ▲ or ▼ buttons are pressed, the UNIT No. flashes and is switched at the same time.
- 4 Press the SET (set) switch**  
The GROUP No. and UNIT No. stop flashing and become on. Setting is done.
  - Please repeat step 3 and 4 to set other units in the displayed group.
  - The later settings take precedence. If a unit has already been set to one group before it is set to another group, this unit will join the later set group.
- 5 Press the TIMER (timer) switch**  
To return to the operation status display of the displayed group No.

### Individual setting method

Setting of units controlled by central controller SLA-2A-E but subject to individual control instead of group control.

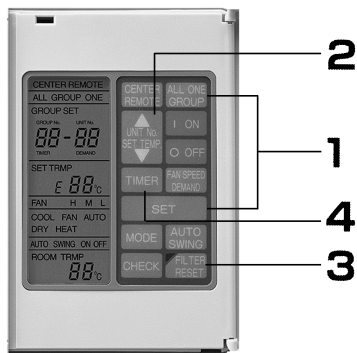

- 1 Press SET (set) switch and ALL / GROUP / ONE (simultaneous/group/individual) switch at the same time.**  
The setting mode is activated with characters "00 – 00" flashing.
- 2 Press UNIT No. / SET TEMP (unit No. / room temperature) to select units to be set for individual control.**  
When the ▲ or ▼ are pressed, the UNIT No. flashes and can be switched at the same time.
- 3 Press the FILTER RESET (filter reset) switch**  
The UNIT No. display changes from flashing to lighting and the GROUP No. display becomes "--". Setting is done.
- 4 Press the TIMER (timer) switch**  
To return to the operation mode display of the displayed unit No.

### About the setting of central controller / remote controller

Select the centralized control of the object units controlled by central controller SLA-2A-E or the mobile control through the remote controller on the unit side.

■ **Setting details and switch operability**

Setting details	Switch operability
Central controller	Only operation through central controller SLA-2A-E is possible. Operation through the remote controller on the unit side is not permitted.
Central remote controller	Operation is possible either through central controller SLA-2A-E or the remote controller on the unit side. The later setting operation takes precedence.
Remote controller	Operation through central controller SLA-2A-E is not permitted. Please use the remote controller on the unit side.

**Setting Method**

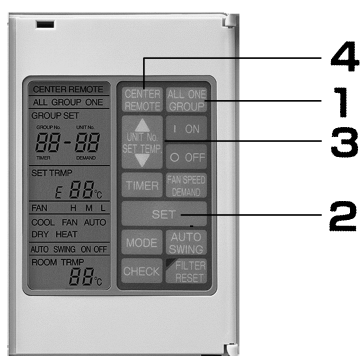

- 1 Please make a selection from simultaneous, individual or group operations for units subject to operation/stop setting.**  
Press ALL / GROUP / ONE (simultaneous/group/individual) switch.  
  
Switch following the sequence of [ ALL → GROUP → ONE ].
- 2 Press SET switch**  
The display of group No. or unit No. flashes.
- 3 Press ROOM TEMP/No. switch**  
Press ▲ or ▼ to select group No. or unit No..
- 4 Press CENTER REMOTE (central controller / remote controller) switch.**  
Switch following the sequence of [ CENTER → REMOTE → CENTER REMOTE ]

Air Conditioning Control System

### Simultaneous operation method

Perform simultaneous operation / stop of all the units controlled.

#### Method a

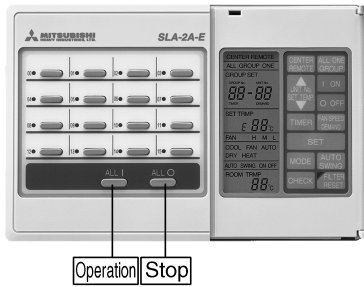

■ **Setting of Operation Details**

Please set the operation mode, room temperature, air rate, etc.

#### Method b

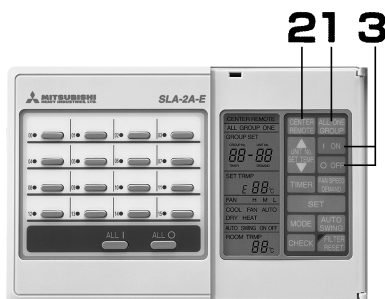

■ **Setting of Operation Details**

Please set the operation mode, room temperature, air rate, etc.

**Operation:** Press the simultaneous operation switch

All the units controlled start running and the operation / abnormality display lamp lights in green.

**Stop:** Press the simultaneous stop switch

All the units controlled stop running and the operation / abnormality display lamp goes off.

**1. Press ALL / GROUP / ONE (simultaneous/group/ individual) switch.**

Switch following the sequence of [ALL→GROUP→ONE]. Please select "ALL (simultaneous)".

**2. Set to "Central Controller" or "Central Remote Controller" through the CENTER / REMOTE (central controller / remote controller) switch.**

**3 Press the Operation or Stop switch.**

▶ **When the Operation switch is pressed...**

All the units controlled start running and the operation / abnormality display lamp lights in green.

▶ **Press the Stop switch...**

All the units controlled stop running and the operation / abnormality display lamp goes off.

### Group operation method

Operation and stop by group

#### Method a

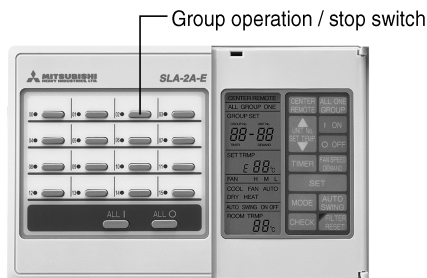

■ **Setting of Operation Details**

Please set the operation mode, room temperature, air rate, etc.

**Operation:**When the air-conditioner stops running (the operation / abnormality display lamp is off), press the group operation / stop switch

All the air conditioners within the group start running and the operation / abnormality display lamp lights in green.

**Stop:** During the operation of the air-conditioner (the operation / abnormality display lamp lights in green), press the group operation/stop switch

All the air conditioners within the group stop running and the operation / abnormality display lamp goes off.

## Method b

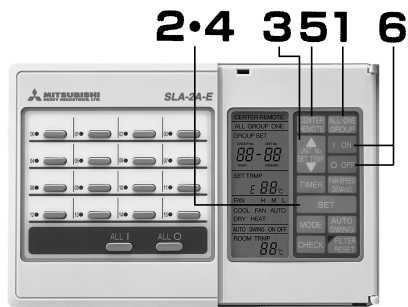

- **Setting of operation details**  
Please set the operation mode, room temperature, air rate, etc.

- 1 **Press ALL / GROUP / ONE (simultaneous / group / individual) switch.**

Switch following the sequence of [ALL→GROUP→ONE]. Please select "GROUP (group)".

- 2 **Press the SET (set) switch.**  
GROUP No. (group No.) display flashes.
- 3 **Press UNIT No. / SET TEMP (unit No. / room temperature) switch.**  
Press ▲ or ▼ to select the group No.  
•Display of the operation status of the selected group.
- 4 **Press the SET (set) switch.**  
GROUP No. (group No.) lights.
- 5 **Set to "Central Controller" or "Central Remote Controller" through the CENTER / REMOTE (central controller / remote controller) switch.**
- 6 **Press the Operation or Stop switch.**
  - ▶ **When the Operation switch is pressed...**  
All the air conditioners within the selected group start running and the operation / abnormality display lamp lights in green.
  - ▶ **Press the Stop switch...**  
All the air conditioners within the selected group stop running and the operation / abnormality display lamp goes off.



### Individual operation method

Only operate the selected ones among the connected units.

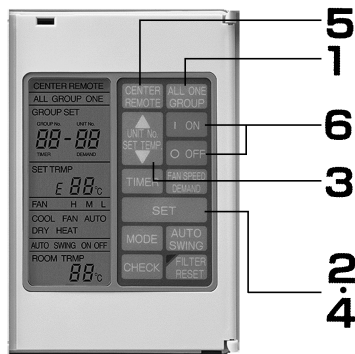

**1 Press ALL / GROUP / ONE (simultaneous / group / individual) switch.**

Switch the mode following the sequence of → ALL → GROUP → ONE . Select "ONE (individual)".

**2 Press the SET (set) switch.**

UNIT NO. (unit No.) display flashes.

**3 Press UNIT No. / SET TEMP (unit No. / room temperature) switch.**

Press ▲ or ▼ to select the unit No.

- Display of the operation status of the selected unit.

**4 Press the SET (set) switch.**

UNIT No. (unit No.) lights.

**5 Set to "Central Controller" or "Central Remote Controller" through the CENTER REMOTE (central controller / remote controller) switch.**

**6 Press the Operation or Stop switch.**

- ▶ When the Operation switch is pressed...  
The selected units start running and the operation / abnormality display lamp lights in green.
- ▶ Press the Stop switch...  
The selected units stop running and the operation / abnormality display lamp goes off.

■ **Setting of operation details**

Please set the operation mode, room temperature, air rate, etc.

## Operation details setting method

Setting of the operation mode, room temperature, air rate and automatic swing.

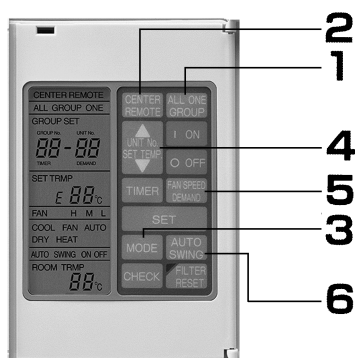

### ■ Standard for room temperature setting

Cooling .....	26~28°C
Drying .....	21~24°C
Heating .....	22~24°C
Air supply.....	room temperature setting is not required

### 1 Setting of ALL / GROUP / ONE (simultaneous / group / individual)

- ▶ For simultaneous operation, please set to "ALL (simultaneous)".
- ▶ For group operation, please make group setting following the sequence of Step 1, 2, 3, and 4 in **Method b**
- ▶ For individual operation, please set following the sequence of step 1, 2, 3, and 4 in Page 347.

### 2 Set to "Central Controller" or "Central Remote Controller" through the CENTER REMOTE (central controller / remote controller) switch.

### 3 Setting of the operation mode

Press MODE (operation mode) switch.

Switch the mode following the sequence of →automatic→drying→heating→cooling→air supply.

### 4 Setting of room temperature

Press ▲ or ▼ to set the room temperature.

### 5 Setting of air rate

Press FAN SPEED (air rate changeover) switch to switch following the sequence of fast ↔ strong ↔ weak.

### 6 Setting of automatic swing

Press AUTO SWING (automatic swing) switch to switch between AUTO SWING ON ↔ AUTO SWING OFF.

### Hints

- During the room temperature setting, please confirm the displays of GROUP No. (group No.) and UNIT No. (unit No.). Press SET (set) switch if the displays are flashing and then press ▲ or ▼ after the lighting is confirmed.
- For multi KX series, please use a uniform operation mode for each of the indoor units. In case different operation modes are set, the later setting will be cancelled and the unit will operate in the forced air supply mode with the operation mode display flashing.
- The operation may stop when the room temperature setting switch is pressed to increase or decrease the set room temperature. The reason is that the room temperature regulator is working instead of getting into trouble.
- The air rate changes automatically with the room temperature when the unit is running in the drying mode. Air rate setting through the FAN SPEED switch is not possible in this case.

### Timer operation method

Timer function is not available in central controller SLA-2A-E. When connected to a weekly timer and a commercially available timer, this unit is able to perform timer operation.

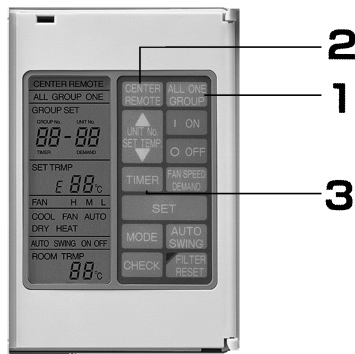

**1 ALL / GROUP / ONE (simultaneous / group / individual) setting**

- ▶ For simultaneous operation, please set to "ALL (simultaneous)".
- ▶ For group operation, please set the groups for timer operation following the sequence of step 1, 3, 4, and 5 in **Method b**.
- ▶ For individual operation, please set the groups for timer operation following the sequence of step 1, 3, 4, and 5 in Page 347.

**2 Set to "Central Controller" or "Remote Central Controller" through the CENTER / REMOTE (central controller / remote controller) switch**

**3 Press the TIMER (timer) switch**

Switch the mode following the sequence of

→TIMER→no display→.

Select "TIMER (timer)".

Setting of units running in the timer mode is thus completed.

■ **Timer operation**

The unit set with the timer operates / stops with the signals from the external timer.

■ **Release of timer operation**

Press the TIMER switch to set the timer display to no display. The timer operation is disabled.

## Demand unit setting method

Demand control function is not available in SLA-2A-E central controller. Demand control is possible when the unit is connected to a demand controller.

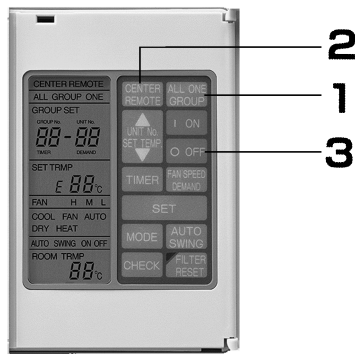

### 1 ALL / GROUP / ONE (simultaneous / group / individual) setup

- ▶ Please set to "ALL (simultaneous)" to enable all units.
- ▶ For group settings, please set the groups for the demand setting following the sequence of step 1, 3, 4, and 5 in **Method b**.
- ▶ For individual operation, please set the groups for the demand setting following the sequence of step 1, 3, 4, and 5 in Page 347.

### 2 Set to "Central Controller" or "Remote Central Controller" through the CENTER / REMOTE (central controller / remote controller) switch

### 3 Press the SET (set) switch and the FAN SPEED / DEMAND (air rate changeover/demand) switch at the same time. Switch the mode in the sequence of [→DEMAND→no display]. Select "DEMAND (demand)".

Setting of the demand operation is thus completed.

- Disconnecting the jumper wire (J1) in advance can prohibit the mobile remote control over the set units by external signals. When the external signals are released, the Central Controller / Remote Controller returns to the original status.

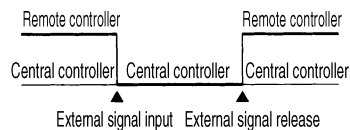

The demand operation does not run at this moment.

#### ■ Demand operation

Units that have been set to the demand operation status shut down the thermostat following the signals from the external demand controllers. After the signals are released, they will return to the original operation status.

#### ■ Release of demand setting

Press SET switch and FAN SPEED / DEMAND switch at the same time to set the demand display to no display.

Demand operation is thus disabled.

**When the operation / abnormality display lamp lights in red**

■ **An abnormality occurs to the air-conditioner**

- When the operation / abnormality display lamp corresponding to the group No. where the abnormal unit is located lights in red, the abnormal unit stops running. The LCD switches to the abnormality display shown in the following diagram and the displays of the operation mode, room temperature, air rate and automatic swing become blank.

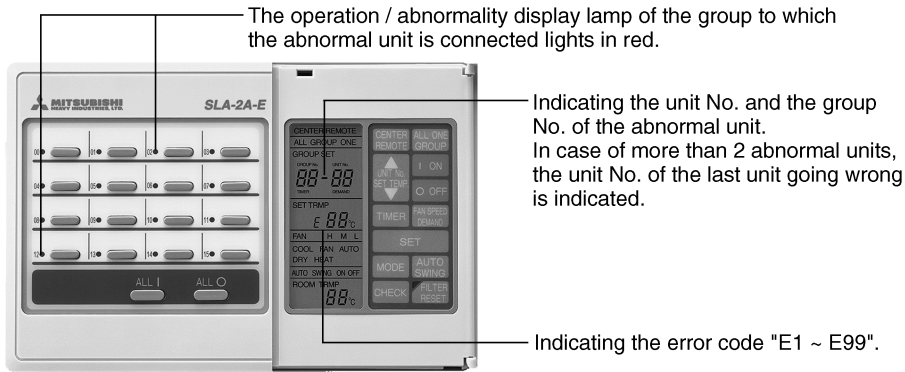

■ **Please get in touch with the sales outlet where the respective unit was purchased and provide information including the "error code", "error characteristics", "model name of the abnormal unit".**

- In case of more than 2 abnormal units, the unit No. of the abnormal unit and the corresponding error code are switched to every time when the check switch is pressed.

(Example)

Switch the display in the sequence of 02-10→08-05→02-00 when there are 3 abnormal units, 02-00, 02-10 and 08-05 respectively and 02-10 is currently displayed.

■ **Abnormality display reset**

- Press ALL / GROUP / ONE (simultaneous/group/individual) to return to the usual operation status display.

**When the filter sign lights**

■ **Please clean the filter**

(Refer to the operation manual attached with the air-conditioner for the cleaning method.)

- The filter sign lights when the total operation time of any one unit among the connected indoor units reaches the set time.

**Confirmation of the unit No. with the filter sign on**

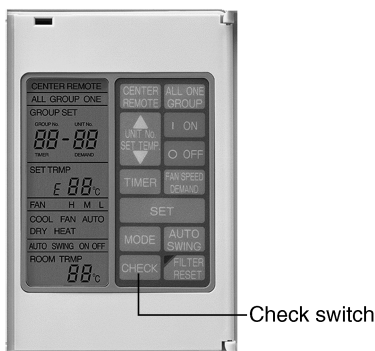

- While the filter sign is lighting, press the check switch and the group No. and unit No. shown in the filter sign will be displayed for 10 seconds and then the original display returns. In case there are more than 2 units generating the filter sign, every pressing of the check switch will switch the unit No.

**Filter sign reset** (Please reset the filter after the cleaning)

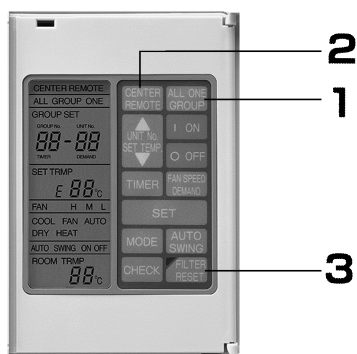

- 1 **ALL / GROUP / ONE (simultaneous / group / individual) setting**
- 2 **Set to "Central Controller" or "Central Remote Controller" through the CENTER / REMOTE (central controller / remote controller) switch.**
- 3 **Press FILTER RESET (filter reset) switch.**  
 Simultaneous: The filter sign lights and all units are reset.  
 Group : The filter sign for the displayed groups lights and all units are reset.  
 Individual : Only the displayed individual units are reset.

### Hints

The filter sign can be disabled through central controller SLA-2A-E. Please get in touch with the sales outlet of the air-conditioner.

### Usage guidance

#### ■ About ROOM TEMP (air suction temperature) display

The following contents are displayed during the operation of the units:

- During the simultaneous and individual operation: the air suction temperature of the displayed units is displayed.
- During the group operation : the air suction temperature of the unit with the smallest unit No. among the displayed groups is displayed.

Below 13°C	:	displayed as 13°C
From 14°C~34°C:	:	display between 14°C and 34°C by 1°C.

#### ■ About ALL / GROUP / ONE (simultaneous/group/individual) setting

- When set to ALL (simultaneous): All settings are possible for all the connected units and the operation status of the currently displayed unit is displayed.
- When set to GROUP : Various settings are possible by group. The operation status of the unit with the smallest unit No. in the group is displayed.
- When set to ONE (individual) : Various settings are possible by unit. The operation status of the currently displayed unit is displayed.

#### ■ About power failure compensation

The setting status at the moment right before the power failure is memorized when the power source of the central controller SLA-2A-E is cut off due to power failure. Upon the power recovery, the air-conditioner that was running before the power failure resumes operation.

Besides, the power failure compensation function can be disabled. Please get in touch with the sales outlet of the air-conditioner.

# Installation Manual of Central Controller SLA-2A-E

## Safety Cautions

- Please read these "Safety Cautions" first before the actual execution of the installation work.
- If the cautions described herein are key points related to safety matters and must be strictly observed.
- After completing the installation, please perform the test run and confirm there is no abnormality found. Meanwhile, explain the operating methods to the customer.
- Moreover, ask the customer to keep this Installation Manual appropriately.

## Warning

- Please entrust either the sales outlet where the unit is purchased or a professional personnel for the installation.
- Improper installation by the customer himself may result in electric shocks, fires, etc.
- The installation must be executed in accordance with this installation manual. Improper installation may result in electric shocks, fires, etc.
- The electrical work should be executed by a licensed electrician following the "safety standards related to electrical equipment", "local regulations", as well as the installation instructions. Improper installation may result in electric shocks, fires, etc.
- Specified cables should be used for the wiring connections. Ensure that the external force of the cable is not applied to the terminal connection part by properly securing the wiring connections. Improper connection or securing may result in heat generation, fires, etc.
- Always use the attached parts or specified products for setup construction. Use of components not specified by our company might result in electric shock, fires, etc.

## 1 Applicable models All J series

## 2 Accessories (Please confirm the following accessories)

① Central controller	② Power source kit	③ Optional wiring	④ Operation manual	⑤ Switch display label	⑥ Small flat screw M4×L20×60cs	⑦ Small flat screw M4×L10×4cs	⑧ Installation cover of JIS box	⑨ Spring

### Signal wire

- Size : 0.75mm<sup>2</sup>-2.0mm<sup>2</sup>
- Wiring material : standard wires (shielded wires in case of any interference)
- Allowed extension length : within 1,000m.

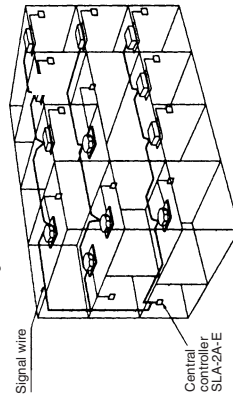

- Up to 3 central controllers SLA-2A-E are connectable to one network. In addition, combination with central controller SLA-2A-E is also possible. The maximum number of connectable SLA-1-E corresponding to the number of connected SLA-2A-E is shown in the following table.

SLA-2A-E	SLA-1-E
1	3
2	2
3	0

- When central controller SLA-2A-E is used, the standard remote controller may be omitted. However, for double-unit, triple-unit, quadruple-unit and multi-unit types, the master remote controller is required even if SLA-2A-E is used. In addition, the standard remote controller is also required when wired auto-cleaning panels / flexible panels / step-down cleaning type panels are used.

PJZ012D0022B

## 3 Wiring instructions

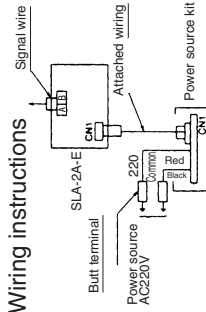

- (1) Example of the weekly timer usage
- When connected to the weekly timer (SCA-WT-E), the SLA-2A-E does not need special wiring and settings.

## (2) Example of the usage of external timer input, etc.

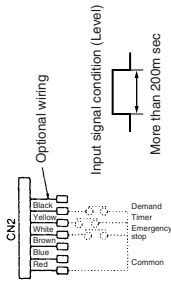

## 4 Installation work

- (1) Please embed in advance the signal wire used by the Electrical box and central controller SLA-2A-E as well as the power cord used by the power source kit.
- (2) Please remove the cover of the power source kit. The cover is not to be used. Use screws to fix the central controller SLA-2A-E.
- (3) Connect up the power cord.

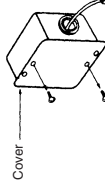
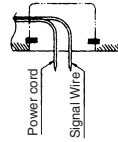

Note) Confirm the power voltage and connect power source correctly.

- (4) Open up the upper case of central controller SLA-2A-E and install the power source kit to SLA-2A-E.

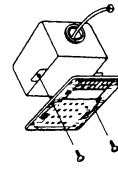

- (5) Use the accessory ⑥ small flat screw to fix the central controller SLA-2A-E on the Electrical box.

- (6) Connect up the signal wire (terminal A, B) and the connector (CN1).

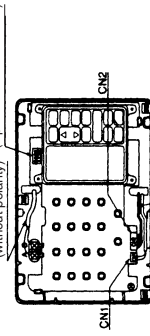

- Please connect the power source for the central controller 2 minutes after the unit power is connected.

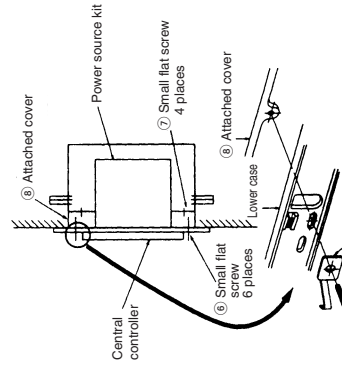

- The cover ⑥ can be omitted and replaced with part ① at two places to secure the JIS box.
- Please use ⑤ in case of any deformation of the lower electrical box. The securing operation should be performed at up to 6 places. Please use ⑤ to fix ⑥ on the JIS box in advance.

Note) Central controller SLA-2A-E is specially used for embedding installation. Attention should be paid to the following aspects if separate installation has to be done (with the central controller SLA-2A-E installed separately from the power source kit):  
 \*Please make sure that the power cord between the central controller and the power source kit is less than 4m in length.  
 \*Accessory ③ spring must be installed.

**5 Control Switch**

The following controls can be changed by changing the setting of switch SW 32 on the printed circuit board. Change the control on-site as necessary.

Switch No.	Setting	Control function
1	ON(factory default)	Filler sign valid
	OFF	Filler sign invalid
SW32	ON(factory default)	With blackout compensation
	OFF	No blackout compensation(*)
3	ON(factory default)	Normal(**)
	OFF	Normal(**)
J1	Shorted(factory default)	Remote control operation is prohibited and the operation mode is fan when the demand is input.
	Open	Remote control operation is prohibited when the demand is input.
J2	Shorted(factory default)	Auto mode can be set.
	Open	Auto mode cannot be set.
J3	Shorted(factory default)	CENTER/REMOTE setting can be changed.
	Open	CENTER/REMOTE setting cannot be changed.

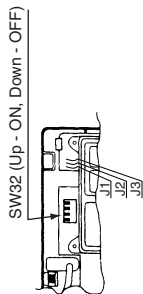

(\*) Even in the case of "no blackout compensation", group setting is maintained in the case "with blackout compensation", the unit is operated before the blackout will be operated after the blackout.  
 (\*\*) Leave 3 of SW32 at the ON position.

**6 Setting of Units Controlled**

Please set the units controlled by central controller SLA-2A-E in the following steps. All the units in the network have been logged on to the group No. 15 at the delivery from the factory. There are the following 3 types of setting.

- Setting of units controlled by central controller SLA-2A-E but not subject to the group control. → [B] (2) Please refer to the Group Setting.
- Setting of units controlled by central controller SLA-2A-E. → (3) Individual setting.
- Setting of units not controlled by central controller SLA-2A-E. → (4) Deletion. (or units desired to be controlled by other central controllers.)

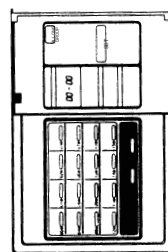

01 Group Selection

- Entering the Setting Mode  
 Enter the setting mode to set ①, ②, ③.  
 Press **(SET)** (set) button and **(ALL ONE)** (GROUP) (simultaneous/group/individual) button at the same time. The display is shown as the right diagram with characters "00 - 00" flashing.

- Group Setting  
 Up to 16 groups can be set with central controller SLA-2A-E. Setting of any unit in the group is possible.  
 a) Please select the group to be set through the group buttons on the left. The selected No. is displayed as the Group No. (group No.) and flashes.

- Please select the unit to be set with the **(UNIT)** buttons. With every pressing of the button, the Unit No. (unit No.) scrolls and flashes.

PJZ012D022B

- Confirm by pressing **(SET)** (set) button. If the Group No. and Unit No. light instead of flashing, the setting is confirmed.  
 \* Please repeat Step b) and c) to set other units in the displayed group. Please repeat Step a), b) and c) to set other groups.  
 The later settings take precedence. For example, if a unit has already been set to a certain group before it is set to another group, this unit will join the one set later. (The same unit can not log on to different groups.)

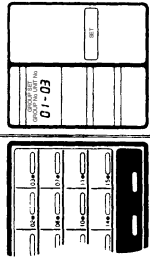

- Individual Setting  
 The following settings should be made for air-conditioners not desired for the group control:  
 a) Please select the unit to be set through the **(UNIT)** buttons. With every pressing of the button, the Unit No. scrolls and flashes.  
 b) Please confirm the setting by pressing **(FILTER/RESET)** (filter reset) button. If the Group No. is indicated as "..." and lights together with the Unit No., the setting is confirmed.

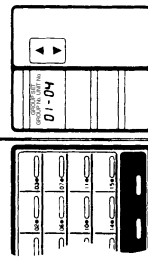

- Deletion  
 Please set as follows for units desired to be deleted from the control objects of central controller SLA-2A-E:  
 a) Please select the unit to be set by pressing the **(UNIT)** buttons. With every pressing of the button, the Unit No. scrolls and flashes.  
 b) Press **(FILTER/RESET)** (filter reset) button. (Same as the setting in Step (3) (b)).  
 c) Press **(FILTER/RESET)** (filter reset) button again to confirm. If "..." display goes off and only the Unit No. (unit No.) lights, the setting is confirmed.

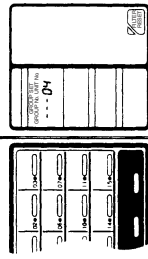

- End  
 Press **(TIMER)** (timer) button at any one of displays (1) to (4) to return to the operation status display of the last displayed group No. (normal mode).

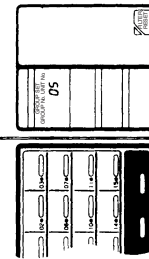

- Group control when multiple controllers are used  
 Free group setting by each of the central controllers SLA-2A-E is possible when multiple SLA-2A-E are used in one network.

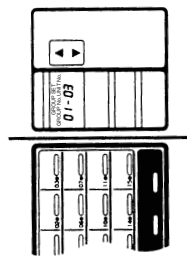
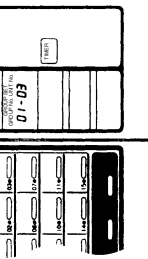



## 5.3 Weekly Timer SCA-WT-E

### Component description and function

All the contents are recorded on the LCD for explanation.

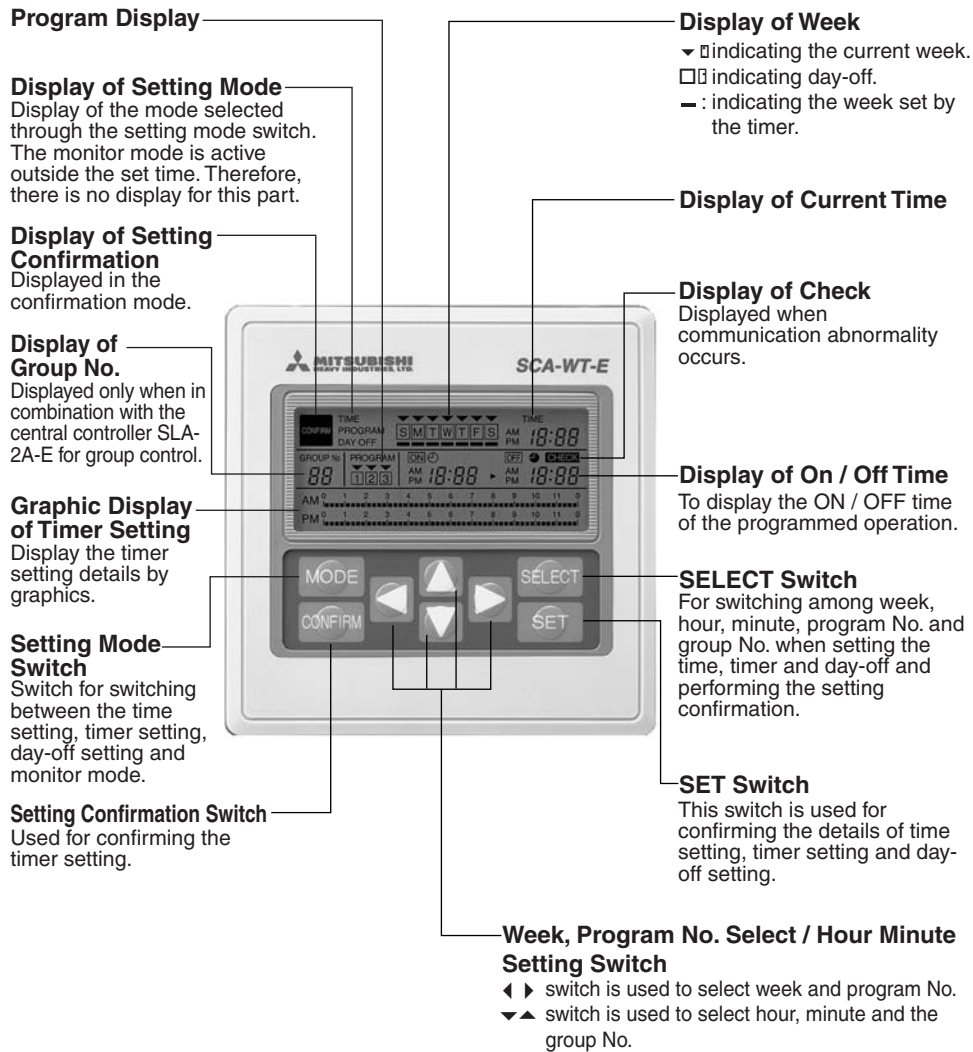

## Week &amp; current time setting

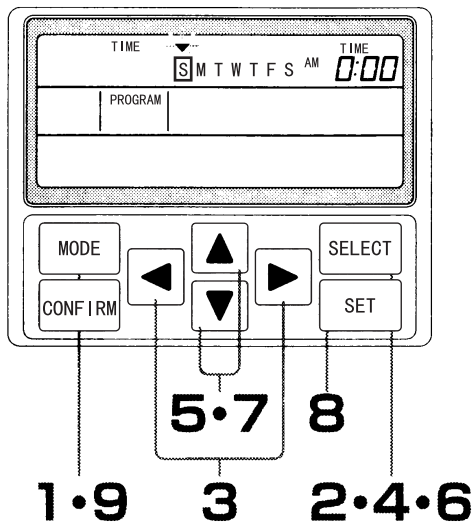

- 1 **Press MODE (setting mode) switch**  
TIME (time setting) is displayed in the setting mode.
- 2 **Press SELECT (select) switch**  
The symbol ▼ flashes on the indicator of week.
- 3 **Make the symbol ◀▶ point to the current week by pressing ▼ switch.**
- 4 **Press SELECT (select) switch**  
The "hour" part of the TIME (current time) flashes.
- 5 **Adjust the "hour" of the TIME (current time) by pressing ▲▼ switch.**
- 6 **Press SELECT (select) switch**  
The "minute" part of the TIME (current time) flashes.
- 7 **Adjust the "minute" of the TIME (current time) by pressing ▲▼ switch.**
- 8 **Press SET (set) switch**  
The display changes from flashing to lighting and the week and current time setting is done.
- 9 **Press MODE (setting mode) switch to change the display of the setting mode to no display.**  
Return to the monitor mode.

**Hints**

- Keep the ▲▼ switch pressed when setting hour and minute, which can speed up the setting.
- Keep the ◀▶ switch pressed when setting week, which can speed up the setting.
- When the switches are not operated for 60 seconds, the setting will automatically return to the monitor mode. Please operate once again.

### Setting of programmed operation

3-cycle programmed operation can be set for each day of a week.

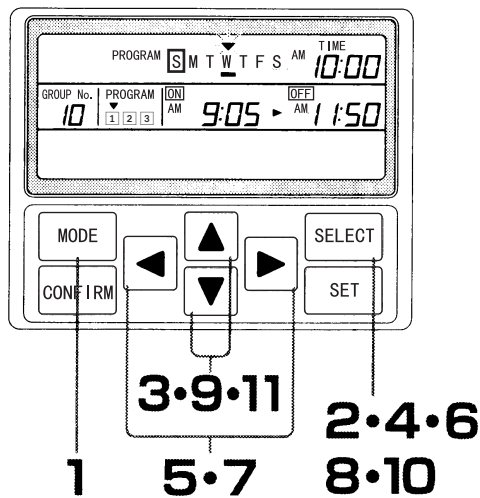

(Example) To operate the air-conditioners in the group No. 10 on Wednesday according to the following program:

- Program ① : operate during 9:05 a.m.~11:50 a.m.
- Program ② : operate during 1:05 p.m.~5:00 p.m.

1 Press MODE (setting mode) switch to display PROGRAM (timer setting).

2 Press SELECT (select) switch

GROUP No. (group No.) 00 flashes.

- When not used in combination with central controller SLA-2A-E, the Group No. is not displayed and the symbol ▼ above the week flashes. Please continue the operation from Step 5.

3 Set GROUP No. (group No.) to 10 by pressing switch.

4 Press SELECT (select) switch.

The symbol ▼ above the week flashes.

5 Make the symbol ▼ point to "W (Wednesday)" by pressing switch.

6 Press SELECT (select) switch.

The symbol ▼ below the PROGRAM (program) flashes.

7 Make the symbol ▼ point to ① by pressing switch.

8 Press SELECT (select) switch.

The "hour" part of (power-on time) flashes.

9 Make it point to AM 9:-- by pressing switch.

10 Press SELECT (select) switch.

The "minute" part of (power-on time) flashes.

11 Make it point to 05 by pressing switch.

#### Hints

- Keep switch pressed when setting the group No., hour and minute, which can speed up the setting.
- When the switches are not operated for 60 seconds, the setting will automatically return to the monitor mode. Please operate once again.

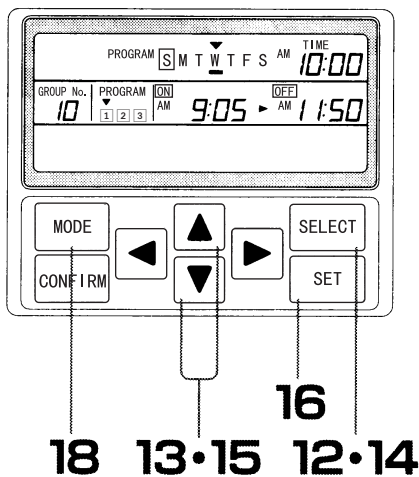
**12 Press SELECT (select) switch**

The "hour" part of **OFF** (power-off time) flashes.

**13 Make it point to AM 11:-- by pressing ▲ switch.****14 Press SELECT (select) switch**

The "minute" part of **OFF** (power-off time) flashes.

**15 Make it point to 50 by pressing ▲ switch.****16 Press SET (set) switch**

Setting for the program ① is done. The flashing display turns into lighting. "—" is displayed below the set "W (Wednesday)" and the set time is displayed in graphics.

**17 Continue to set the program ②**

Please set according to Step 6-16 shown above.

- Press SET (set) switch to finish the setting for the program ②. The flashing display turns into lighting at this moment and the set time is displayed in graphics.

**18 Press MODE (setting mode) switch to change the display of the setting mode to no display.**

Return to the monitor mode.

**19 The programmed operation for other dates can be set following the same steps.****Hints**

- Setting the GROUP NO. (group No.) to 88 can make all the groups operate according to the same program.
- Move the week in proper order to select both S~S (Sunday~Saturday) and M~F (Monday~Friday). This method can be used if the same program is used for the whole week or on ordinary days.  
S(Sunday) ↔ M(Monday) ↔  
T(Tuesday) ↔ W(Wednesday) ↔  
T(Thursday) ↔ F(Friday) ↔  
S(Saturday) ↔ M(Monday)~  
S(Saturday) ↔ S(Sunday) ~  
S(Saturday) ↔ S(Sunday)
- Keep ▲ switch pressed when setting hour and minute, which can speed up the setting.
- When the switches are not operated for 60 seconds, the setting will automatically return to monitor mode. Please operate once again.

**■ ON/OFF Time Setting Rules**

- Please set the ON time to -:- a.m. (morning) if only the OFF time is set. The On time can not be set alone.
- Regard the OFF time as the one in the next day if the ON time is later than the OFF time.  
**(Example)** If Wednesday 10:00 p.m. ~ 7:00 a.m. is set, the operation time will be: 10:00 p.m. Wednesday to 7:00 a.m. Thursday.
- If full day operation is required, please set the time to 0:00 ~ 0:00.
- In case of overlapped programs, only the first ON time and the last OFF time are valid.

**(Example 1)**

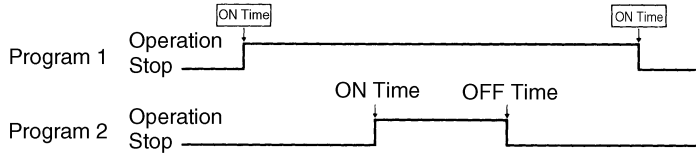

In this case, Program 2 is included in the set time of Program 1. Therefore, only the ON time and OFF time in Program 1 are valid.

**(Example 2)**

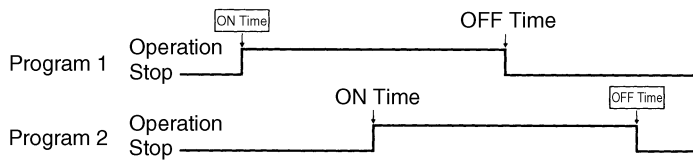

In this case, the ON time of Program 1 and the OFF time of Program 2 are valid. The result is shown in the following diagram.

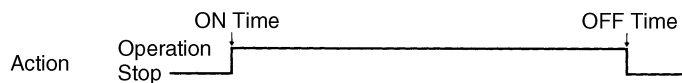

- When the OFF time equals to the next ON time, the unit will perform the continuous operation.

**(Example)** If 10:00 a.m. ~ 1:00 p.m. and 1:00 p.m. ~ 7:00 a.m. are set, the unit will operate continuously from 10:00 a.m. to 7:00 p.m..

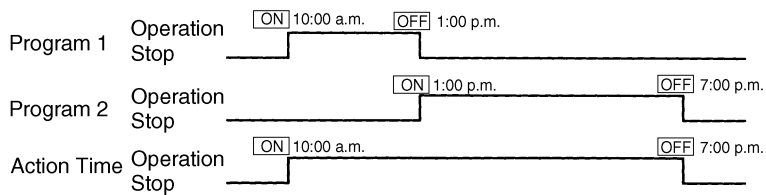

## Day-off setting

The timer setting by day can be temporarily cancelled through the day-off setting.

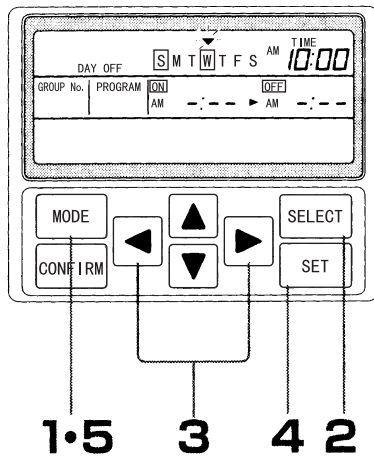

**[Example] To set Wednesday as a day-off:**

- 1 Press **MODE (setting mode) switch** to display **DAY OFF (day-off setting)**.
  - 2 Press **SELECT (select) switch**  
The symbol ▼ flashes on the week.
  - 3 Make ▼ point to **"W (Wednesday)"** by pressing ◀▶ switch.
  - 4 Press **SET (set) switch**  
When a square frame is added around W (Wednesday) and "W (Wednesday)" is displayed, the setting is done.
  - 5 Press **MODE (setting mode) switch** to change the setting mode display to no display.  
Return to the monitor mode.
- To cancel the day-off setting, follow the above steps to make ▼ point to the weekday to be cancelled and press SET (set) switch.

## Method of clearing setting details

The timer setting, current time and day-off settings can be cleared.

Press SET (set) switch and MODE (setting mode) switch at the same time. All the details set are cleared.

### Confirmation of time set by timer

The time set by the program timer can be confirmed.

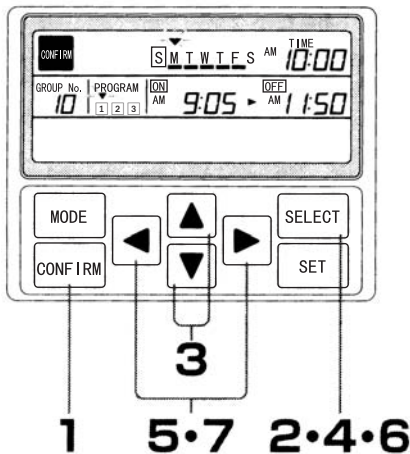

- 1 **Press CONFIRM (setting confirmation) switch**  
CONFIRM is displayed.
  - 2 **Press SELECT (select) switch**  
GROUP No. (group No.) 00 flashes.
    - When not used in combination with central controller SLA-2A-E, the group No. is not displayed and ▼ symbol above the week flashes. Please continue the operation from Step 5.
  - 3 **Select the group No. to be confirmed by pressing** switch
  - 4 **Press SELECT (select) switch**  
▼ symbol above the week flashes.
  - 5 **Make ▼ symbol point to the week to be confirmed by pressing** switch
  - 6 **Press SELECT (select) switch**  
▼ symbol above the PROGRAM (program) flashes.
  - 7 **Make the ▼ symbol point to the program No. to be confirmed by pressing** switch.
    - The ON / OFF time of the timer is displayed.
- Press CONFIRM (confirm) switch again to return to the monitor mode.

#### Hints

- Keep switch pressed when selecting the group No., which can speed up the setting.

### When the check display appears

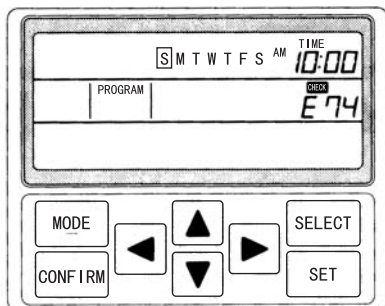

- **Communication abnormality occurs**
  - In case of an abnormality, CHECK (check) is displayed above the OFF time and the error code is displayed at the display area of the OFF time. All the displays become blank except for the current time and week.
- **Please get in touch with the sales outlet where the respective unit was purchased and provide information including the "error code", "abnormality characteristics", and so on.**

## About power failure compensation

### Hints

- The power failure compensation function is available in the weekly timer SCA-WT-E (which is set to invalid at the delivery from the factory).  
Please get in touch with the sales outlet of the air-conditioner.

### ■ About Power Failure Compensation Function

- The setting status can be memorized when the power source for the weekly timer SCA-WT-E is disconnected due to power failure, etc.. Upon power recovery, the weekly timer may select to operate or stop based on the setting status at the time of the power recovery.

### (Example)

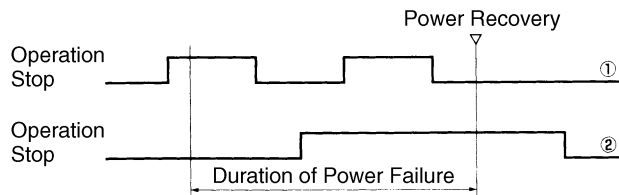

### When the timer is set as shown in the above diagram ①

The timer is set to stop upon the power recovery. Therefore, the air-conditioner stops.

### When the timer is set as shown in the above diagram ②

The timer is set to operate upon the power recovery. Therefore, the air-conditioner starts to operate.



# Installation Manual of Weekly Timer

## Safety Cautions

- Please read these "Safety Cautions" first before the actual execution of the installation work.
- The cautions described herein are key points related to safety matters and must be strictly observed.
- After completing the installation, please perform the test run and confirm there is no abnormality found. Meanwhile, explain the operating methods to the customer. Moreover, ask the customer to keep this Installation Manual appropriately.





## Warning

- Please entrust either the sales outlet where the unit is purchased or a professional personnel for the installation. Improper installation by the customer himself may result in electric shocks, fires, etc.
- The installation must be executed in accordance with this installation manual. Improper installation may result in electric shocks, fires, etc.
- The electrical work should be executed by a licensed electrician following the "safety standards related to electrical equipment", "local regulations" as well as the installation instructions. Improper installation may result in electric shocks, fires, etc.
- Specified cables should be used for the wiring connections. Ensure that the external force of the cable is not applied to the terminal connection part through properly securing the wiring connections. Improper connection or securing may result in heat generation, fires, etc.
- Always use the attached parts or specified products for setting work. Use of components not specified by our company might result in electric shock, fires, etc.

## 1 Applicable Models

### J Series Heat Pump Types and Cooling Only Types

## 2 Accessories

① Weekly Timer	② Power source kit	③ Operation Manual	④ Small Flat Screw
			
			M4 x 25 x 2pcs.

## • Components to be prepared on site

- JIS C 8336 Lead Box
- JIS C 8336 Switch Cover
- Medium-sized Four-cornered Deep Type
- Coated Double Type

## 3 Wiring Instructions

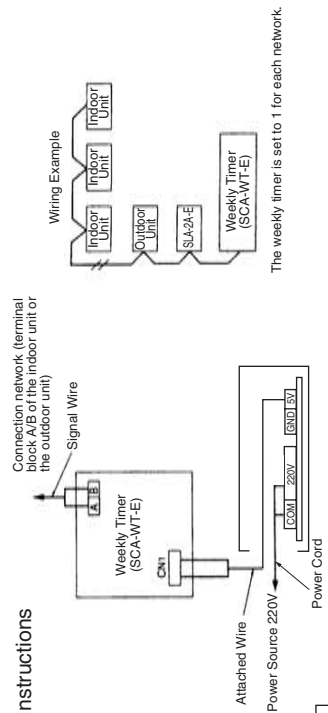

## 4 Installation Instructions

- (1) Please embed the signal wire used by the JIS box and the weekly timer as well as the power cord used by the power source kit.

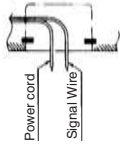

- (2) Please remove the cover of the power source kit. The cover is not to be used. Use screws to fix the weekly timer.

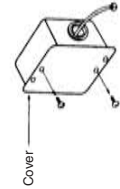

Note) Please confirm the power voltage.

- (3) Connect up the power cord.

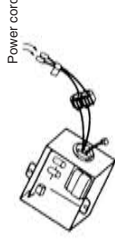

- (4) Open up the upper case of central controller SLA-2A-E and install the power source kit.

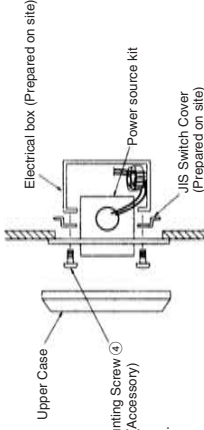

Use the screws with the power source kit cover installed.

- The weekly timer is specially used for embedding installation. Attention should be paid to the following aspects if separate installation has to be done.
- Please make sure that the power cord between the weekly timer and the power source kit is less than 4m in length.
- Please always close the locking hole above the centre when securing the weekly timer.

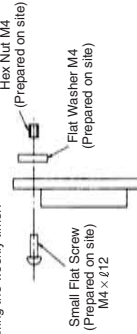

- (6) Connect up the signal wire (terminal A, B) and the connector.

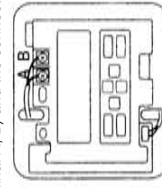

## 5 Control Switching

The following control switching is possible through the control switch.

Switch to the left for OFF, right for ON. There are 4 changeover switches. Do not change the third and fourth ones (which are fixed to OFF). Please switch the control before power source is connected.

1	ON	Group start / stop is possible if used together with SLA-2A-E
	OFF	Facilitating the centralized start / stop of all indoor units in the network. It delivers from the factory
2	ON	The operation / stop command is issued when power is recovered.
	OFF	No operation / stop command is issued when power is recovered. It delivers from the factory

Note) • If start / stop operation by group is required, always use one SLA-2A-E. • If the group can be set by SLA-2A-E.

- When the changeover switch No. 1 is OFF, the indoor units in the network perform the timer operation no matter whether the central remote controller is used. When the changeover switch No. 1 is ON, the timer units are set through SLA-2A-E and only the indoor units controlled by the central controller or the central remote controller perform the timer operation.
- Press SET (set) switch and MODE (setting mode) switch simultaneously to clear the timer and day-off settings.

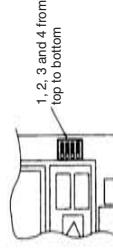

Note) Please connect the power source of the weekly timer 2 minutes after the unit power is connected.

# Part 6

## Service

<b>1. Test Run</b>	<b>598</b>
1.1 Standard Multi (FDCA140HKXEN4)	598
1.1.1 Procedure of test run	598
1.1.2 "Check on construction" by servicemen	598
1.1.3 Check before test runs	600
1.1.4 Points for test runs	604
1.2 Standard and Combination Multi (FDCA224HKXE4 ~ FDCA1360HKXE4)	611
1.2.1 The purpose of test run	611
1.2.2 The total flow of test run	612
1.2.3 Service tool required for test run	613
1.2.4 Installation check	615
1.2.5 Check before test run	616
1.2.6 Pairing (indoor / outdoor units combination) check	621
1.2.7 Unit evaluation by test run switch (SW)	624
1.2.8 Submission to Entrusted Construction Unit	629
1.2.9 References	630
<b>2. Troubleshooting</b>	<b>636</b>
2.1 Before Starting Troubleshooting	636
2.1.1 Confirmation of the error code on the remote controller (by pressing the inspection switch) and the inspection display and normal display lamps on PCBs (Printed circuit board) of indoor / outdoor units	636
2.1.2 Procedures of trouble diagnosis	643
2.1.3 Diagnosis by the power supply reset	644
2.2 Operation Flowcharts	645
2.2.1 Indoor unit operation flowchart	645
2.2.2 Outdoor unit operation flowchart	649
2.3 Error Diagnosis Procedures at the Indoor Unit Side	650
2.4 Error Diagnosis Procedures at the Outdoor Unit Side	661
2.5 Inspection Method When There Is No Error Display	683
2.6 Functions of the Control Circuit Board of the Outdoor Unit	685
2.6.1 Control cabinet of the outdoor unit KX4 series (5 - 12 HP)	685
2.6.2 Control cabinet of the outdoor unit KX4 series (12 - 24 HP)	686

# 1. Test Run

## 1.1 Standard Multi (FDCA140HKXEN4)

### 1.1.1 Procedure of test run

The test run is work to confirm the following item and that it can meet the user's needs without incompatibility.

**(1) Confirmation of construction**

- ① Use limitations: total number of indoor units / capacity, L / H of refrigerant pipe ... equipment drawing or inspection with ears and eyes.
- ② Refrigerant pipe: Pipe size, branching pipe, brazing, and heat insulation, airtight test, and vacuum drawing...equipment drawing or inspection with ears and eyes.
- ③ Refrigerant changing: this machine meets the Chargeless specification and the changing of refrigerant portion for local piping is unnecessary.
- ④ Electric wiring: Capacity of breaker, signal wire type, and mis-connection confirmation ...equipment drawing or inspection with ears and eyes.
- ⑤ Confirmation on Combination of indoor / outdoor units: As combination of refrigerant system / address ...equipment drawing or inspection with ears and eyes.
- ⑥ Address: Confirmation of the equipment drawing.

**(2) Confirmation before test run**

- ① Confirmation before turning on power: check if there are mixed wiring connections among signal wires and power wires ...measuring the resistance between terminals AB.
- ② CH energizing time confirmation ... Inspection.
- ③ Confirmation on Combination of indoor/outdoor units: Operating outdoor unit at every one system ...QSS checker or the dip switch.

**(3) Test run**

- ① From acquisition of operating data to judgment
- ② Existence confirmation of wound in equipment / construction and repair treatment (request to construction contractor etc.)

Remarks: necessary meter etc. : The pressure gauge, tester, the clamping meter, and the thermally sensitive resistor thermometer.  
(QSS checker and checker of air conditioner)

### 1.1.2 "Check on construction" by servicemen

Confirm if construction is being properly done by inspection (partly check) before turning on power supply. This check is necessary for trouble prevention at test run and after test run.

**(1) Check on use limitations related with equipment designs.**

- The check is chiefly done by listening and investigation of actual conditions, and the correction treatment is proposed to the trader.

No.	Item	Reference	Result	Content of treatments	Treatment date
1	The number in which indoor unit can be connected	① Refer to following note (1)		Indoor unit addition or separation	
2	Capacity in which indoor unit can be connected	① Refer to following note (1)		Indoor unit addition or separation	
3	Is the driving always under the state of the capacities unbalancing between indoor unit and outdoor unit	① It is not preferable that a small capacity indoor unit alone is operating for a long time with respect to a large capacity outdoor unit.			
4	Limitation on refrigerant piping length	① Main pipe ≤ 70m ② Branch pipe (The first branch to Indoor unit) ≤ 30m		Corrections within the use limitation.	

5	Height difference between indoor unit and outdoor unit	① The outdoor unit is the above the indoor units : $\leq 30\text{m}$ ② The outdoor unit is the below the indoor units : $\leq 15\text{m}$		Same as above	
6	Height difference between indoor units	① $\leq 4\text{m}$		Same as above	
7	Installation space (indoor / outdoor units)	① Refer to space limitation in this book.			

Note (1) Number in which indoor unit can be connected (When the number exceeds, abnormally stop [E43].)

The number in which indoor unit can be connected (unit)	1 ~ 8	1 ~ 6
Capacity in which indoor unit can be connected (%)	80 ~ 130	80 ~ 150

(2) The correction of the above-mentioned all items is proposed to the construction contractors.

## (2) Check related with construction

- The check is chiefly done, and then the correction is proposed to the trader .

No.	Item	Reference	Result	Content of correction <sup>(1)</sup>	Treatment date
1	Capacity of breaker for power supply	① Capacity described in material (excessive to improper protection) ② With the leak breaker (INV unit corresponding to INV)		Correct according to left mentioned.	
2	Local wiring terminal processing	① Use terminals for the connection to the terminal block.		Correct according to left mentioned.	
3	Parallel wiring of signal wire and power supply wiring (high voltage)	① Separate when longer than 0.5m (The binding of a strong signal / power supply wiring is improper if longer than 10m). ② Using coaxial cable for signal / power supply wiring is improper.		Correct according to left mentioned.	
4	Is there mixed use of signal wire and strong electric wire?	① Resistance between terminals A and B ( $\Omega$ ) $\approx 9100\Omega \div$ (number of indoor units and outdoor units and SLA)		Correct before turning on power.	
5	Material of refrigerant pipe	① Is the size proper? (Refer to material) ② Is the branch pipe used pure and installing method		Correct according to left mentioned.	
6	Was the airtight test done?	① Specified pressure : R22 = 2.94MPa R407C = 3.23MPa		Correct according to left mentioned.	
7	Vacuum drawing	① Has vacuum been drawn in 60 minutes after pressure reaches to 750Mhg?		Correct according to left mentioned.	
8	Refrigerant changing	① This machine meets the Chargeless specification and the additional changing of refrigerant portion for local piping is unnecessary.		Correct according to left mentioned when not treating.	
9	Address (indoor / outdoor units)	① Confirmation with the equipment drawing. ② Have the addresses of outdoor and the sub unit been set?			
10	Drain check of indoor unit	① Was drain check done?		Check during test run	

Remark : Correction is requested to the construction contractor and confirm later.

### 1.1.3 Check before test runs

Do test run after the following matter is confirmed before test runs

If test run is done directly with omitting the following procedures, troubles that have been no confirmed might occur sometimes after it is handed over.

**(1) Confirm if mixed use of signal wires and power supply wires exists ... Confirm before turning on power supply**

- When getting entangled is missed, damage of the control boards of a lot of indoor units/outdoor units (Damage of the super-link communication circuit ... destruction of the zener diodes etc. on this circuit) might be caused.

**Confirmation method on entanglement of wires**

- ① Measure the resistance ( $\Omega$ ) between A and B at arbitrary terminals "A, B" in the super-link. (Refer to the right photograph).
- ② There is no entanglement of wires if the measured resistance is approximately equal to the calculation value by the following expression.  
Resistance ( $\Omega$ ) =  $9100 \div (\text{number of units})$ .  
Note (1) number of units = (number of indoor units + number of outdoor units + number of SL).  
Where, SLA-1, SLA-2A are one respectively.

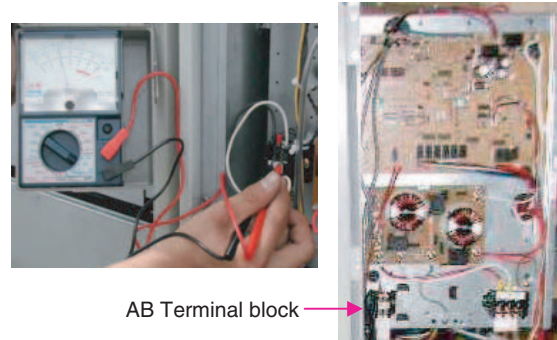

Figure 6.1 Resistance measurement between A-B of super-link signal wire (Confirm if there is entanglement between signal wire and power wire)

**(2) Confirm that service valve of outdoor unit has been opened ... Confirm before operating**

- Operator confirms that service valves of both master and sub units have been made full open, before it begins to run.

**[If it begins to operate under the state of the service valve closing, as a result, a vacuum running the compressor fault will be caused]**

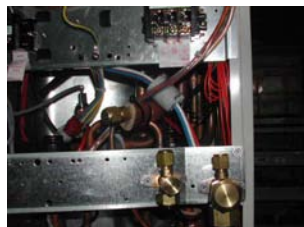

Figure 6.2 Service valve (Left: oil balancing tube, middle: Gas tube and the right: liquid tube)

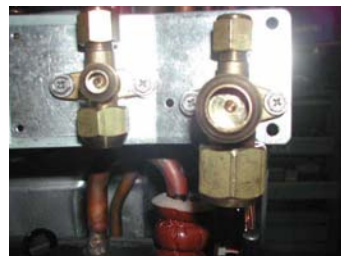

Figure 6.3 Liquid / gas service valve (Shown in figure is full open). (Operate with a hex-head wrench.)

Attention : If the operation valve has been closed at test run, confirms whether the construction contractor has completed vacuum drawing and airtight test and refrigerant changing and opened the service valve. If this confirmation is neglected, the air entering (no condensation gas and water) or forgetting of additional refrigerant charging for local portion will be caused at the end of vacuum drawing.

**(3) Confirmation of insulation and power-supply voltage**

- (a) Insulation confirmation
  - The confirmation is requested to be done by the installer or dealer if necessary.
- (b) Power-supply voltage confirmation
  - Confirm power-supply voltage before test run starts
  - Confirm carefully while all units is running fully

**(4) Pairing (confirmation of indoor unit / outdoor unit combination)**

- Purpose: For the combination of the indoor unit and the outdoor unit, the refrigerant pipes are connected according to the equipment blueprint, or / and the addresses of indoor unit / outdoor unit are set according to the equipment drawing, as the result, the combinations of indoor and outdoor on the signal and the refrigerant piping connection are completed.  
If the design changes under construction were transferred between both piping construction contractor and operator who set address or address setting was wrong<sup>(1)</sup>, imperceptible mismatch of the pairing between indoor and outdoor would occur.
- Irregularities due to pairing mismatch: The following serious incompatibilities occur. A test run of this system cannot be done until the disagreement is corrected.
  - ① Not cooling / not heating.
  - ② When cooling: Heat exchanger was frozen. ⇒ water leak (protect ion function is hardly lost with the float switch).
  - ③ When heating: high-pressure anomaly (E40) ... It changes with the number etc. of the indoor units operating.
  - ④ When cooling and heating: discharge temperature abnormality (E36) ...It changes with the number etc. of the indoor units operating.
  - ⑤ When cooling: It might cause compressor incompatible due to liquid flood back ...It changes with the number etc. of the indoor units operating.

(a) Pairing confirmation-I: Use the QSS checker or checker of air conditioner.

- The confirmation procedure: these works are done on the outdoor unit side.

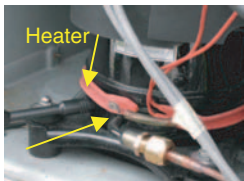
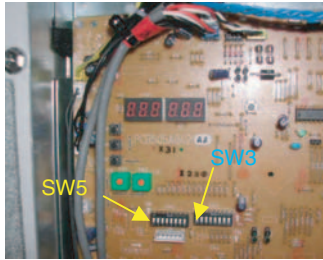
No.	Work content	Remarks
1	① Is the Energized time of crankcase heater (CH) more than 30 minutes? (go to the following item 2 if more than 30 minutes). ② If less than 30 minutes <ul style="list-style-type: none"> <li>• Go to item 2 if the temperature of the compressor dome ≥ saturation temperature at stop +10.</li> <li>• The rise of the temperature of the compressor dome is waited for, if the temperature of the compressor dome ≤ saturation temperature at stop +10.</li> </ul>	 <p>Measurement position</p> <p>Figure 6.4 CH conducting and temperature of dome</p>
2	① Confirm the number and address of combinational indoor units. • Obtain the equipment blueprint (Or, listening), and understand whole content of air conditioning facilities ② Connect QSS (the checker of air conditioner) to terminals A and B of outdoor unit etc., all indoor units combined with this outdoor unit are selected and started-up.	<ul style="list-style-type: none"> <li>• Acquire address list before confirmation of pairing</li> <li>• Terminals A and B can be anywhere.</li> <li>• Being able to check 8 units at most with QSS at the same time</li> </ul>
3	① Run only the outdoor unit to be checked for pairing. <ul style="list-style-type: none"> <li>• The operation is done with the test run switch etc. (on the main unit control board)                             <ol style="list-style-type: none"> <li>1) SW5-2 (cooling / heating selection switch): cooling ... ON, and heating ... OFF</li> <li>2) Next, SW5-1 ( test run switch): ON.</li> </ol>                             Note (1) SW5-1 and 2 are the 1st and 2nd switches respectively from the left of the arrow on right figure.                             Remarks 1. When you turn SW5-1 ON, the compressor should begin to run immediately or within tens of seconds. If the compressor do not run, turn test run switch OFF and turn it on again after three minutes.                             2. Go to he following procedure if the CH conducting time is less than 30 minutes.                             <ol style="list-style-type: none"> <li>a) Turn SW3-4 ON. Then begin to run with the test run switch etc..</li> <li>b) After all outdoor units for the test run is similarly run for about 30 minutes, all the outdoor units are stopped. Then run each outdoor unit and do pairing check as above-mentioned.</li> </ol> </li> </ul>	 <p>Figure 6.5 Position of test run switch.</p> <ul style="list-style-type: none"> <li>• This is because it takes time till compressor run at full speed with CH control during less than 30 minutes after turning power on for all outdoor units.</li> </ul>

4	<p>① Confirm that temperature of heat exchanger of all indoor units at operation mode decreases when cooling and rises<sup>(1)</sup> when heating with QSS (the checker of air conditioner).                  Note (1) compared with stopping, cooling: 5 ~ 10deg heating: 10 ~ 20deg                  There are variations in the temperature with the capacity of the indoor unit.                  Remark: Temperature variation is different with the operating state of the compressor. In general, it takes from a few minutes to about ten minutes.</p> <p>② After the confirmation on rising / decreasing in temperature of heat exchanger of all indoor units, turn SW5-1 and 2 OFF and stop running. Then confirm how the temperature of heat exchanger of all indoor units changes to the temperature corresponding before operating.</p>	<ul style="list-style-type: none"> <li>• If there are a lot of indoor units, monitoring is done several times in the following time left shown, or monitoring is done with heat exchanger monitor of indoor unit as the same time.</li> <li>• Confirm under indoor heat exchanging mode if the checker of air conditioner is being used .</li> <li>• The temperature change confirmation after the outdoor unit stops is effective to the pairing confirmation even when other outdoor units are running by any chance.</li> </ul>
---	--	--

(b) Pairing confirmation II: Use "operating data" display function of remote controller

- The confirmation procedure: these works are done on the remote controller side of the indoor unit.

No.	Content of works	Remarks
1	The CH energizing time and the temperature of the compressor dome are confirmed.	• Reference to pairing confirmation method • 1 mentioned in former page
2	Operate each outdoor unit.	• Reference to pairing confirmation method • 3 mentioned in former page
3	Heat exchanger temperature of all indoor units are confirmed with "operating data display" of remote controller. <ul style="list-style-type: none"> <li>• Confirm that temperature of heat exchanger of all indoor units at operation mode decreases when cooling and rises when heating.</li> </ul> Note (1) Compared with stopping, Cooling : 5 ~ 10deg Heating : 10 ~ 20deg	• Reference to pairing confirmation method • 4 mentioned in former page

"Operating data" display function of remote controller

- This series adopts the remote controller with a new specification. Operating data of all indoor units and outdoor units connected with same super-link (table below) through one remote controller can be displayed on the liquid crystal part of the new remote controller in real time.
- "Operating data" list displayed by remote controller

Number	Data item of indoor unit	Range of display	Number	Data item of outdoor unit	Range of display
01	Operation mode	Cooling / heating / dehumidification / ventilation	21	Outdoor temperature	-20 ~ (°C)
02	Preset temperature	18 ~ 30 (°C)	22	Temperature of outdoor heat exchanger	-20 ~ (°C)
03	Temperature of suction air	Over 0°C	24	Operating Hz	0 ~ 100 (Hz)
04	Temperature of indoor heat exchanger 1	Same as above	25	High-pressure	0.0 ~ (MPa)
05	Temperature of indoor heat exchanger 2	Same as above	26	Low pressure	0.00 ~ (MPa)
06	Temperature of indoor heat exchanger 3		27	Temperature of outlet tube	30 ~ (°C)
07	Speed of the indoor fan		28	Temperature under dome	-20 ~ (°C)
08	Demand frequency		29	CT Current	0 ~ (A)
09	Response frequency				
10	Expansion valve opening	0 ~ 480 (Pulse)	37	Expansion valve opening 1 (Heating)	0 ~ 500 (Pulse)
11	The indoor operating time	0 ~ 25500h	38	Expansion valve opening 2 (Cooling)	0 ~ 500 (Pulse)

Notes (1) Number: it is displayed on up right corner of liquid crystal of remote controller, and it shows what displayed data item is.

- (2) The data item and the display range: It is displayed on lower dot display part of the remote control liquid crystal as shown in the above table and data with units is displayed on the right side within the range shown in the table.

Remarks : Procedure for displaying data on remote controller

The following operation can be done regardless of operating / stopping of the air-conditioner, data can be also displayed.

**Procedure :**

- ① Press "Check" button.
  - "Operating data display ▼ " is automatically displayed for a few seconds.
- ② While "operating data display" is being displayed, "Set" button is pressed.
  - The least address of indoor unit is displayed and flashed like "indoor 00".
- ③ After the desirable address of the indoor unit is selected with the "◆" button, "Set" button is pressed.
  - The display of address changes from flashing to normal, and after about two seconds, display changes into "Data is being read".
  - It will change into data in about 30 seconds.
- ④ Switches to desirable data item (01-38) with the button "◆" referring to the above table.  
(Continue displaying this data concerned if there is no operation.)
 

Remark: The data of the outdoor unit: If an arbitrary indoor unit combined with the outdoor unit to be confirmed in signal is selected and an arbitrary data number (from 21) of the outdoor unit is input according to the table above, the data of this outdoor unit can be displayed. (If an arbitrary outdoor unit is selected by the address, data of the outdoor unit alone cannot be displayed.)
- ⑤ When changing to another indoor unit with different address, if "Air conditioner No" button is pressed, display is switched to the indoor unit address selection.

**Remarks**

1. If you want to return to previous screen in the above-mentioned operation, press "Reset" button. Display is changed into the previous one screen. If "Reset" is pressed many times, the operating data display ends and returns to a usual display (operating / stop).
2. For release of the operating data display, even if not using the above-mentioned method, as long as the operating / stop button is pressed, usual display can be returned at once (operating / stop). (In this case, the unit operating (stop) can not be stopped (started).)



## 1.1.4 Points for test runs

### 1.1.4.1 Purpose of test runs

Test run procedure described in the next pages to confirm whether the following each item is satisfied for all units at the site. If there are incompatibilities to be corrected, responsibility trader is requested to correct. After corrected, if necessary confirmation is to be done again.

In other words, this work is to confirm that air-conditioning equipment can be handed over to the user without any irregularity.

- ① At the final phase of test run, it is confirmed that there are no any fault and possibility of fault occurring. It is judged according to the following 3 data items.
  - If there was defect in the equipment, the repair including part exchanging etc has been completed.
- ② How to acquire data items / data of equipment side that should be confirmed at test run.
  - 1) Indoor unit: Confirm the following items and whether cooling / heating is normal by running all connected indoor units.
    - a) The operation confirmation of the expansion valve ... Confirm it by measuring temperature of heat exchanger or return / supply air temperature with QSS etc..
 

Notes (1) The temperature of heat exchanger and return / supply air temperature and operation of the expansion valve: Check with QSS (the checker for air conditioner).

(2) Return / supply air temperature: Measures it with the thermometer etc.

(3) If there are violent liquid backs caused by uncertain factor when cooling and high-pressure rise etc caused by uncertain factor when heating, it is guessed that their reasons may be defective operation of fan / expansion valve or a defective pairing.

Remark: When it is presumed that the operation of the expansion valve etc. of this indoor unit is defective and some indoor unit is defective from the data measured for outdoor unit, temperature measurements of suction and discharge air are done. It is not necessary to measure for all indoor units.
    - b) Air circulation short circuit and fan operation (air flow rate) confirmations: inspection, and if necessary, temperature and air flow rate measurements are done.
    - c) It is confirmed that there are no anomalous sound and vibration.
  - 2) Outdoor units: Confirm under both full loads and partial loads (The indoor unit is partially operated). Data aims at confirming whether the amount of the refrigerant is proper and the operations of various protection controls and the related functional components (solenoid valve, fan, and compressor) are consistent with the control specification and that there is no any fault.
 

The precondition of above mentioned is following.

    - ① Understanding the content of the operating control with the handbook etc. beforehand and then confirm whether the operation of the functional component while operating is normal.
    - ② Firstly confirm the reference operating data (Refer to the page) is, and then to be able to judge whether the operation is normal immediately while test running.
    - ③ Refrigerating cycle and the electric wiring diagram and the refrigerant charge amount are understood and memorized.
      - a) As basic data besides the compressor operating state (frequency and sub unit state) is acquired and all the data of the indoor unit and the outdoor unit (Refer to the data sheet on the page) at the same time is acquired. Data acquisition should be rapidly completed within 2-3 minutes. Data acquisition is done again when operating state of compressor changes.
      - b) Data (supply temperature, pressure, current of the compressor, and temperature of each pipe, etc.) is acquired after the stable state (that is, begin the acquisition of data after the compressor has operated for over 10 minutes) is reached.
 

When operating state changes, the change tendency is understood and it is confirmed how the maximum / minimum is and that there is no abnormality.
      - c) Data is acquired over two times under full load and partial load respectively.
      - d) Confirm that there are no anomalous sound and vibration.
      - e) Confirm that there are no contacts between pipes and contact and stretching of wiring to vibration body.
    - 3) Data is preserved according to the article and made available for the maintenance service in the future.
- ③ When defects related with construction occur, either of the following treatment should be taken.
  - Correction should be done by dealer or contractor, and after correction it is checked again if necessary.
  - If requested correction was not carried out, means (business charge, supplier or owner) with which it can be proved that correction has been requested. (This is for later trouble with user)

Note: After the test run ,settings of switch, etc. dedicated for test run must be reset to the original.

- ① test run switch (SW5-1, 2) of outdoor unit is set OFF without fail.
- ② Service switches (SW3-4) of outdoor unit are set OFF without fail too.
- ③ The setting of the remote control switch that changed is returned to its original setting.

**1.1.4.2 Flow of test runs (Details will be described from next pages)**

For one outdoor system, it takes the procedure and time shown in the figure below roughly to do test run.

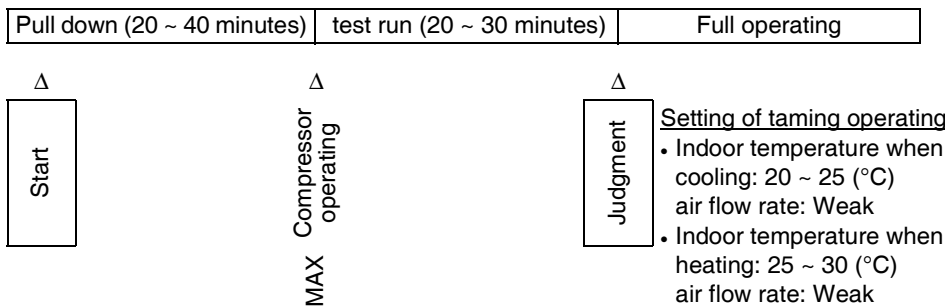

Note (1) The operating from beginning operating to reaching roughly (thermostat OFF) to the preset indoor temperature by remote controller etc. is called pull-down. It also overlaps with the time taken till CH control after power supply of main machine turning on is cleared, and compressor reaches full operating responding to the demand of an indoor unit, and.

**1.1.4.3 Test run points when operating data display function and outdoor 7 segment function of remote controller are used.**

- A necessary data item (The record is done with the data sheet shown in the end of this book) for the test run check.
  - \* Outdoor unit:
    - ① Compressor operating frequency, current of compressor, temperature of discharge tube, and temperature under dome, the temperature of heat exchanger, high-pressure, low-pressure, and opening of expansion valve.  
[Operating data displayed on remote controller]
    - ② Another piping temperature: Temperature of compressor suction tube (system overheating level confirmation).
  - \* Indoor unit:
    - ① Demand frequency, response frequency, opening of expansion valve, the temperature of heat exchanger, temperature of return air, and air flow rate.  
[With operating data displayed on remote controller]
- Necessary meter (Use it for the verification of data displayed on the remote controller and the data measurement not obtained by the remote controller)  
Clamp meter, gauge manifold, thermally sensitive resistor thermometer, and tester.
  - ① First of all, the operating data displayed on remote controller is read out and recorded on the indoor unit and the remote controller side (The data sheet in the end of a book is used).  
Next, the same data item is measured on the outdoor unit side and that the data is approximately same compared with the remote controller data (That is, sensor data of the outdoor unit) is confirmed.

No.	Content of work	Remarks
1	(1) Begin test run of system for which confirmation has been completed Operating method ① Begin cooling or heating operation with "test run switch (SW5-1, 2)" of outdoor unit Remarks 1. at the period: a high-pressure control when heating and antifrost control of indoor unit when cooling might operate such that steady full operation of the compressor cannot continue. 2. When the power supply is reset, the operation is allowed to be started after over three minutes since power supply turned ON. ② Operation is started with remote controller etc. if operation with test run switch. is not convenient. However, at this time, the air flow rate setting of indoor unit should be set to "H". (2) It will take 20 to 30 minutes for the compressor to reach rating operation due to the CH control even if operation begins.	* Refer to ④ page about the test run method.  Figure 6.6 Position of test run switch * Refer to related technological material about details of the CH control.

Test run (Continued)

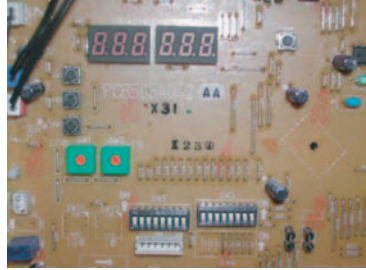
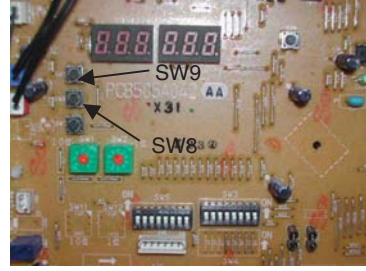
No.	Content of work	Remarks
2	<p>Data item that should be acquired and measuring method and points</p> <p>(1) Items acquired from display data of remote controller</p> <p>(a) The compressor operating frequency, current of compressor, high-pressure, low-pressure, temperature of discharge pipe, temperature under dome, temperature of heat exchanger and the opening of the expansion valve.</p> <p>(b) Indoor unit (Acquire the following data for all indoor units) Address, demand frequency, opening of expansion valve, temperature of heat exchanger, return air temperature and fan speed</p> <p>(2) Data acquired directly (This item cannot be acquired by remote controller)</p> <p>(a) Outdoor unit (Acquire with 7 segment display on board)</p> <p>① Temperature of suction pipe of compressor [7 segment code No / 16]</p> <p>② Level of superheating of system [7 segment code No / 18]</p> <p>(b) Indoor unit</p> <ul style="list-style-type: none"> <li>• Basically, the above-mentioned checker data is enough.</li> <li>• The temperature of the discharge air is measured if necessary.</li> </ul> <p>Remarks</p> <ol style="list-style-type: none"> <li>1. Use the data sheet in the end of a book for recording data.</li> <li>2. The following data related with outdoor unit is acquired by measuring two arbitrary outdoor units (1 ~2) in test run to confirm that there is no big gap in data compared with data displayed by remote controller or 7 segment on the outdoor board.</li> </ol>	<p>* Data is rapidly acquired. The data of the indoor unit is continuously acquired before the operating situation of the outdoor unit changes (frequency of the compressor, and operation of the protection control).</p>  <p style="text-align: center;">Figure 6.7 segment display (Left: code No. is displayed right: Data is displayed.)</p> <p>* The data shown left is covered in "KX driving data sheet" in the end of a book.</p>
3	<p>Confirm that the compressor has operated at rated frequency.</p> <ul style="list-style-type: none"> <li>• If the value of "7 segment code No:00" is the following, the value denotes ratings frequency. <ul style="list-style-type: none"> <li>* Cooling = 68Hz</li> <li>* Heating = 72Hz</li> </ul> </li> </ul> <p>(2) In the following cases, though frequency might not reach rating Hz, it is normal and but the data can be acquired.</p> <ol style="list-style-type: none"> <li>① When operating with test run switch <ul style="list-style-type: none"> <li>• When cooling: The antifrost operates (The control begins with 3.5°C setting at shipment)</li> <li>• When heating: High-pressure control operates (The control begins with 3.52MPa if SW3-3 OFF)</li> </ul> </li> <li>② When operating with remote controller etc.: Set thermostat OFF, besides the above-mentioned.</li> </ol>	

Note (1) Data list displayed by 7 segment

Code No	Data item	Range of display	Code No	Data item	
00	Operating frequency or anomaly code	0 ~ 120 (Hz)	20	Current of compressor	0 ~ 50 (A)
02	Outdoor temperature	-20 ~ 43 (°C)	22	Opening of expansion valve (heating)	0 ~ 500 (Pulse)
03	Temperature of heat exchanger	-25 ~ 73 (°C)	25	Opening of expansion valve (cooling)	0 ~ 500 (Pulse)
07	Temperature of discharge pipe	31 ~ 136 (°C)	26	FM01 Rotational speed	Hundreds digit = UH Tens digit = H, Units digit = L
10	Temperature under compressor dome	5 ~ 80 (°C)	27	FM02 Rotational speed	
12	Temperature of power transistor	31 ~ 136 (°C)	28	High-pressure	0 ~ 5.00 (MPa)
16	Temperature of suction pipe	-25 ~ 73 (°C)	29	Low-pressure	0 ~ 2.00 (MPa)
18	Level of suction gas superheating	0 ~ 50 (deg)			

Remarks: How to select code data

- SW9 (Push-button): The numerical of tens digit of the code is switched as 0 ⇒ 1 ⇒ 2 every time it is pushed.
- SW8 (Push-button): The numerical of units digit of the code is switched as 0 ⇒ 1 ⇒ 2 every time it is pushed.

test run (Continued)

No.	Content of work	Remarks																								
4	<p>Confirmation of the operating data and / the timing and record of measurement                      Time is described clearly on the data sheet and data confirmation and measurement and record are done several times per ten minutes (Roughly, for about 30 minutes) according to the following timing.</p> <p>(1) Outdoor unit                      (a) When the protection control doesn't operate</p> <table border="1" data-bbox="368 488 1013 779"> <tr> <td>0 minute ▽</td> <td>About 30 minutes ▽</td> <td>35 minutes ▽</td> <td>45 minutes ▽</td> <td>After 60 minutes ▽</td> <td></td> </tr> <tr> <td>Start</td> <td>Ratings Hz attainment Pull-down completion</td> <td>Data confirmation / record</td> <td>Data confirmation / record</td> <td>Data confirmation / record Judgment of data → completion</td> <td>since then progressive run (end day)</td> </tr> </table> <p>Remark: Though the above-mentioned is about the test run of one system, if several systems are started, the confirmation and the record on other systems can also be carried out in the free time during the periods above-mentioned.</p> <p>(b) When the protection control operates</p> <table border="1" data-bbox="368 1003 1013 1294"> <tr> <td>0 minute ▽</td> <td>About 30 minutes ▽</td> <td>35 minutes ▽</td> <td>40 minutes ▽</td> <td>60 minutes ▽</td> <td></td> </tr> <tr> <td>Start</td> <td>Ratings Hz attainment or pull-down completion</td> <td>Data confirmation / record</td> <td>Data confirmation / record</td> <td>Data confirmation / record Judgment of data → completion</td> <td>since then progressive run (end day)</td> </tr> </table> <p>Remark: The confirmation and record of data are as shown in the above-mentioned. When the operating rate of the compressor changes due to the protection control (decrease), data at the lower bound of the decrease and data at the upper bound at which the protection control operates again should be acquired respectively to see that anomaly has not been resulted from the protection control is confirmed.</p> <p>(2) Outdoor unit</p> <ul style="list-style-type: none"> <li>Recording is done 2 times at the beginning (after 35 minutes) and last phases (after 60 minutes) of data acquisition for outdoor unit.</li> <li>Additionally, it is acceptable only to record temperature of heat exchange if necessary.</li> </ul> <p>(3) Internal check of outdoor unit.                      Carry out the following check between pull-down process etc. and data loggings</p> <ol style="list-style-type: none"> <li>Check whether there is no contact between refrigerant pipe and the capillary. Correct if there is.</li> <li>Check whether there is loosening and removing in fixing of capillary and the refrigerant pipe (stress measures and contact prevention). Correct if there is.</li> <li>Check whether wiring is stretched and makes contact to vibrating pipe. Correct if there is.</li> <li>Check on detection value of sensor (discharge pipe, under dome and current).</li> </ol>	0 minute ▽	About 30 minutes ▽	35 minutes ▽	45 minutes ▽	After 60 minutes ▽		Start	Ratings Hz attainment Pull-down completion	Data confirmation / record	Data confirmation / record	Data confirmation / record Judgment of data → completion	since then progressive run (end day)	0 minute ▽	About 30 minutes ▽	35 minutes ▽	40 minutes ▽	60 minutes ▽		Start	Ratings Hz attainment or pull-down completion	Data confirmation / record	Data confirmation / record	Data confirmation / record Judgment of data → completion	since then progressive run (end day)	<p>* Use "Multi KX series operating data sheet" in the end of a book for recording data.</p> <ul style="list-style-type: none"> <li>Measurement time must be filled. ... Data are evaluated and judged in terms of the tendency of change.</li> <li>The data of the outdoor unit is recorded within 1 to 2 minute when it is steady.</li> <li>When data changes considerably (operating number and operating frequency and Td, and HP / LP etc. of compressors) the data when the variation is maximum and immediately when it reaches steady after the change should be recorded.</li> </ul> <p>For instance, a certain control operates due to changes of data. As a result, whether the control operation is appropriate can be judged by whether data has been recovered. Moreover, whether there is a risk to the anomaly stop can be judged.</p> <p>* The operation of the protection control: The operation of the protection control under the overload condition is not anomalous.</p> <ul style="list-style-type: none"> <li>High-pressure control, current control, and discharge gas temperature control, etc.</li> </ul> <p>* Confirm the following matter when protection control operates and the air condition is not overload (If it is higher temperature than cooling / heating ratings condition, the protection control has to start) such that the protection control operations is more appropriate.</p> <ol style="list-style-type: none"> <li>Indoor and outdoor units: Whether there is short circuit</li> <li>FDUM, FDU, and FDR: It might cause wind shortage that volume setting corresponding to duct has not been done.</li> <li>Mistake of pairing or address.</li> <li>Refrigerant shortage (gas leakage)</li> <li>Based on the comparison of detection from sensor and the measurement, it is checked whether there are defects in sensors (such as Td sensor, current sensor, and pressure switch).</li> </ol> <p>* The data of indoor unit is indispensable data for evaluating the data of outdoor unit. Acquire the data of indoor unit in a way of synchronizing with outdoor data acquisition</p> <p>* Check is based on visual inspection.</p> <div data-bbox="1114 1787 1390 1910" data-label="Image"> </div> <p>Figure 6.8 Measurement position of temperature under compressor dome for master unit No1</p> <p>* The check is carried out by judgment based on the difference of the measurement data and the remote controller data or outdoor 7 segment data.</p>
0 minute ▽	About 30 minutes ▽	35 minutes ▽	45 minutes ▽	After 60 minutes ▽																						
Start	Ratings Hz attainment Pull-down completion	Data confirmation / record	Data confirmation / record	Data confirmation / record Judgment of data → completion	since then progressive run (end day)																					
0 minute ▽	About 30 minutes ▽	35 minutes ▽	40 minutes ▽	60 minutes ▽																						
Start	Ratings Hz attainment or pull-down completion	Data confirmation / record	Data confirmation / record	Data confirmation / record Judgment of data → completion	since then progressive run (end day)																					

No.	Content of work	Remarks
5	<p>Judgment of recorded data</p> <p>When the test run will end in about 60 minutes after it starts, the test run result is judged by comparing the recorded data with the standard operating data given in 598 page (reference) and the following judging standard.</p> <p>(1) Any defect and anomaly should not occur In order to avoid fault occurring more than one time, even if it is a function protecting from stopping abnormally, as long as it occurs one time, its cause must be investigated, and, and correction work (such as exchanging parts and adjusting the refrigerant) must be carried out. After it repaired, check of re-operating is done to confirm that defective cause has been eliminated and there is no any anomalous symptom.</p> <p>(2) Power-supply voltage</p> <ul style="list-style-type: none"> <li>• Discharge voltage is within rated voltage <math>\pm 10\%</math> (running)</li> <li>• Unbalance between phases (measurement) is within <math>\pm 3\%</math></li> <li>• Voltage drop when starting is within <math>-15\%</math></li> </ul> <p>(3) Current of compressor is within the following tolerance</p> <ul style="list-style-type: none"> <li>• less than 23A if outdoor temperature is less than 41°C</li> <li>• less than 25A if outdoor temperature is more than 41°C</li> </ul> <p>(4) Discharge temperature (temperature of discharge pipe when cooling / heating at ratings)</p> <ul style="list-style-type: none"> <li>* When cooling: 90 ~ 110 (°C) / 68Hz</li> <li>* When heating: 85 ~ 115 (°C) / 72Hz</li> </ul> <p>(5) Under dome of compressor temperature</p> <ul style="list-style-type: none"> <li>• At cooling / heating: less than 80°C (For a short time: less than 85°C.)</li> <li>• Level of superheating under dome: 10deg or more Remark: That the level of superheating under the dome is less than 10 degree means that there is liquid backing. Though its influence for a short time is limited, if it continues for longer time, it can result in the breakdown of the compressor.</li> </ul> <p>(6) The operating pressure: Refer to the standard operating data sheet.</p> <p>(7) Temperature of heat exchanger of indoor unit</p> <ul style="list-style-type: none"> <li>• The temperatures of the heat exchanger aren't necessarily uniform among units as the difference in capacity of the indoor unit and temperature of the return air and the ratio of the total capacity of indoor units and outdoor units and difference of model etc..</li> </ul>	<p>* Anomaly detection frequency according to cause</p> <ul style="list-style-type: none"> <li>• Discharge temperature anomaly (E36): five times / 60 minutes [over 130°C]</li> <li>• High-pressure anomaly (E40): Five times / 60 minutes</li> </ul> <p>* Factor and tolerance of variation of temperature of discharge pipe</p> <ul style="list-style-type: none"> <li>• Though the temperature of the discharge pipe changes with the air condition, the piping distance, the number of the indoor units operating, the amount of the refrigerant, and the compressor operating situation, etc., this variations are roughly in the range shown in the left table.</li> <li>• When cooling: The value of a left table might be exceeded due to the temperature. If less than 120°C, it is still thought normal, but if rises from outdoor temperature 35°C up to about 120°C, the check on the amount of the refrigerant is required.</li> <li>• When heating: Similar to cooling roughly. If the temperature of heat exchanger of indoor unit reaches 60°C, high-pressure control will operate and it will rises up to about 120°C.</li> </ul> <p>* The temperature under dome of the inverter compressor: It will rise to about 30 to 50 (°C) if it operates for tens of minutes.</p> <p>* Level of superheating under dome = Temperature for dome - saturation temperature under Low-pressure</p> <p>* The operating pressure changes greatly with air condition, operating situation of compressor, piping distance and the operating situation of indoor unit. Refer to the standard operating data.</p> <ul style="list-style-type: none"> <li>• Take the following treatment, if presumed to be abnormal. <ul style="list-style-type: none"> <li>① Measure return air / temperature of supply air of the machine, and judge quality by simple calculation of capacity.</li> <li>② It is normal if when the machine is operating alone its data is similar to data of other indoor units.</li> </ul> </li> </ul>
6	<p>Attention after test run ends</p> <ol style="list-style-type: none"> <li>① "test run switches (SW5-1,2)" of outdoor unit: Set them OFF.</li> <li>② Return indoor temperature setting of remote controller to customer setting</li> </ol>	

**1.1.4.4 Points for test run when using QSS (the checker of air conditioner)**

Attention: Do not connect more than one QSS or checker of air conditioner to carefully same network. (Otherwise, in the super-link communication density rises and communication error (E5, others) might be caused.)

Necessary meter ① QSS or checker of air conditioner: For acquisition of operating data of indoor and outdoor units

Outdoor unit: The compressor operating frequency, current of compressor, temperature of discharge pipe, temperature under dome, and the temperature of heat exchanger, as well as temperature of piping and operations main units SV1, 2, 63H1, 2, and 63L and the like.

Indoor unit: demand frequency, actual frequency, the temperature of heat exchanger, temperature of suction air, air flow rate, preset indoor temperature, and operating with oil separating etc.

② The clamp meter, the gauge manifold, the thermally sensitive resistor thermometer, and the tester

Attention : Carry out the test run after the pairing is confirmed. Confirm that "the temperature of under dome of compressor  $\geq$  saturation temperature of air under balanced pressure +10".

No.	Content of work	Remarks
1	The test run of the system for which pairing confirmation is completed begins. <ul style="list-style-type: none"> <li>Start to operate by the test run switch or the remote controller etc. of the outdoor unit.</li> </ul>	* Refer to ⑦ page about the test run method.
2	The data that should be acquired and the measurement method and points Remarks: Use the data sheet in the end of a book. for the record of data (1) Outdoor unit: To read data displayed by seven segment on outdoor board <ul style="list-style-type: none"> <li>The compressor operating frequency, current of compressor, temperature of discharge pipe, temperature under dome, high-pressure, low-pressure, and the opening of the expansion valve</li> <li>Temperature of suction pipe and suction superheating level</li> <li>The temperature of heat exchanger , outdoor temperature, FMO1, 2</li> </ul> (2) Indoor unit: To acquire the following data with QSS/ the checker of air conditioner (QSS: Data of 8 indoor units is displayed on one screen ) <ul style="list-style-type: none"> <li>Demand frequency, the opening of the expansion valve, the temperature of heat exchanger, temperature of return air, and address</li> </ul> (3) Data acquired directly (item that cannot be taken with QSS) (a) The outdoor unit: Seven segment data is enough (b) Indoor unit <ul style="list-style-type: none"> <li>Basically, the above-mentioned checker data is enough.</li> <li>The temperature of the supply air is measured if necessary.</li> </ul>	* The data shown left is covered in "KX4 driving data sheet" in the end of a book. ** Data should be rapidly acquired. The data of the indoor unit is should be acquired before the operating situation of the outdoor unit changes (number of operating compressors, frequency of the compressor, and operation of the protection control).
3	Next Confirmation of the operating data and / the timing of measurement and judgment of the recorded data. All of the points after the test run ends are similar to (P-8 to 10) 1.1.4.3.	

## 1.2 Standard and Combination Multi (FDCA224HKXE4 ~ FDCA1360HKXE4)

### 1.2.1 The purpose of test run

#### 1.2.1.1 The meaning and effect of test run

- (1) During test run, it is not adequate for the latest KX Multi system to be only "capable of cooling and heating". In KX4, various technologies are required during air conditioner design, construction and test run, including new refrigerant R410A, combination of multi outdoor units, connection of multi outdoor units with one refrigerant pipe and one super link control wire etc.  
Consequently, it is very important to confirm the air conditioning design and installation work etc. before handing over to the construction consigner.
- (2) Perform the test run according to KX4 Multi system test run instruction manual and submit the test run report so as to take responsibilities as the dealer to the customer (installation consigner), which is helpful for expanding sales in the future.

#### 1.2.1.2 The purpose of test run

The purpose of test runs is to perform test run on all units so as to check that they satisfy the following items. When faults to be corrected are found, put forward request of correction to the person who is responsible. After correction, check again if necessary.

##### 1.2.1.2.1 When test run is to be finished, check to be sure that there are no faults found and no faults will happen.

· When any unit is faulty, make repairs including replacement of components if necessary.

##### 1.2.1.2.2 Data items to be checked on the unit side during test run / data collection method

**(1)Indoor unit:** Operate all the indoor units connected, and check to be sure that there are no faults during cooling / heating operation.

- a) Check the expansion valve operation.....check the heat exchange temperature<sup>(1)</sup> by MentePC or by return / supply air temperature.

Notes ① Heat exchange temperature, suction air temperature, expansion valve operation: check by MentePC.

② Return / supply air temperature: measure by thermometer, etc.

③ In case of liquid backflow in cooling operation or high pressure rise in heating operation and the causes are unknown, it can be supposed that fan / expansion valve are irregular or the pairing is faulty.

④ When it is supposed that the expansion valve of the indoor unit is faulty or it is supposed that indoor unit is faulty by the data measured on the outdoor unit, measure the return / supply air temperature. It is not necessary to do all the measurements.

- b) Check for short circuit, fan operation (air flow rate): check visually. Measure the temperature and air flow rate if necessary.

- c) Check to be sure that there are no anomalous sound or anomalous vibration.

**(2)Outdoor units:** check at full load and partial load (operate some of the indoor units).

Before test run,

- a) **Refer to technical information for contents of operation control in advance.**

- b) Check the **standard operation data** (refer to page 627) **in order to be able to judge promptly whether it is appropriate during test run.**

- c) Understand and remember refrigeration cycle, electrical wiring diagram and refrigerant charge amount.

Notes ① Check the time and at the same time collect all the data of indoor units and outdoor units. Data collection will be completed quickly in 2 ~ 3 minutes. If the operation condition of the compressor changes, data should be collected again.

② Collect data after the stable condition (operation condition of the compressor) lasts 10 minutes. When the condition changes, find out the change tendency and its max / min value, and make sure there will be no faults.

③ Data should be collected at full load / partial load respectively two times or more.

④ Check to be sure that there are no anomalous sound or anomalous vibration.

⑤ Check to be sure that no pipes or wires contact with or are hung on the vibration body.

##### (3)Data saving and control

Test run data should be saved according to each part for future service work.

##### 1.2.1.2.3 One of the following measures should be taken in case of faulty construction.

(1)Request for correction. After correction, check again if necessary.

(2)In order to make required corrections ⇒ adopt a means to prove that the request for correction has been put forward (make contact with installation consigner or the owner via sales department to prevent future disputes with customer).



### 1.2.2 The total flow of test run

#### 1.2.2.1 Installation check and confirmation before test run <do not perform test run before check is completed>

Installation check	Confirmation before test run <address check>
Δ	Δ
<div style="border: 1px solid black; padding: 2px; display: inline-block; writing-mode: vertical-rl; transform: rotate(180deg);">Start</div> <ul style="list-style-type: none"> <li>① About equipment design check</li> <li>② About installation check</li> </ul> <p>After the above checks are completed, fill in the installation check sheet. &lt; For detailed information, refer to page 615 &gt;</p>	<div style="border: 1px solid black; padding: 2px; display: inline-block; writing-mode: vertical-rl; transform: rotate(180deg);">Start</div> <ul style="list-style-type: none"> <li>① Check to be sure that signal wires are not mixed and service valve has been opened, and check the power supply voltage and insulation etc.</li> <li>② Check the error address when power is turned on, and correct it manually until the error is corrected. Do not operate at this time.</li> </ul> <p>&lt; For detailed information, refer to page 615 &gt;</p>

#### 1.2.2.2 Evaluation by actual operation

Perform test run of each outdoor unit system according to procedures and time shown in the table below.

Pairing check (Check by refrigerant operation) (20~30minutes)	Test run (20~30minutes)	Full operation (General evaluation) (Operation time should be as long as possible.)
Δ	Δ	Δ
<div style="border: 1px solid black; padding: 2px; display: inline-block; writing-mode: vertical-rl; transform: rotate(180deg);">Start</div> <ul style="list-style-type: none"> <li>Remote controller setting</li> <li>· Cooling room temperature: 20~25 (°C) Air flow rate: low</li> <li>· Heating room temperature: 25~30 (°C) Air flow rate: low</li> </ul> <p>Perform test run by each system individually and check the heat exchange temperature change of indoor unit. &lt; For detailed information, refer to page 380 &gt;</p>	<div style="border: 1px solid black; padding: 2px; display: inline-block; writing-mode: vertical-rl; transform: rotate(180deg);">Compressor max. operation</div> <ul style="list-style-type: none"> <li>Operation by test run SW</li> <li>· Target pressure (low pressure in cooling operation and high pressure in heating operation) is reached 5~10 minutes after the data collection, and fill this into the standard data sheet. &lt; For detailed information, refer to page 630 &gt;</li> </ul>	<div style="border: 1px solid black; padding: 2px; display: inline-block; writing-mode: vertical-rl; transform: rotate(180deg);">Judgement</div> <ul style="list-style-type: none"> <li>Remote controller setting</li> <li>· Cooling room temperature: 20~25 (°C) Air flow rate: low</li> <li>· Heating room temperature: 25~30 (°C) Air flow rate: low</li> </ul> <p>Operate under above conditions, and make evaluation of discharge temperature and sound, vibration etc. from the point of view of a user.</p>

#### 1.2.2.3 Hand over to the installation consigner

Submit the test run report	Control in our own company (property information registration)
Δ	Δ
<div style="border: 1px solid black; padding: 2px; display: inline-block; writing-mode: vertical-rl; transform: rotate(180deg);">Installation consigner judgement</div> <ul style="list-style-type: none"> <li>① Fill the test run result into the standard data sheet (Excel format).</li> <li>② Summarize the data sheet into a test run report, and submit it to the construction consigner.</li> </ul> <p>&lt; For detailed information, refer to page 615 &gt;</p>	<ul style="list-style-type: none"> <li>① The final data sheet is controlled as our company's property.</li> <li>② Register the test run data into the property information of MASA network (China) via Internet.</li> <li>③ Save test run data as history data in order to reply to customer's request.</li> </ul> <p>(Note) MASA (Mitsubishi Air-conditioner Service Assistant) system</p>

### 1.2.3 Service tool required for test run

In KX4 Multi system, the outdoor unit printed wiring board of the main unit has incorporated a standard function as MentePC below of collecting operation data of all indoor units connected and outdoor units and saving the operation data. The function will be used as service tool for address check and test run.





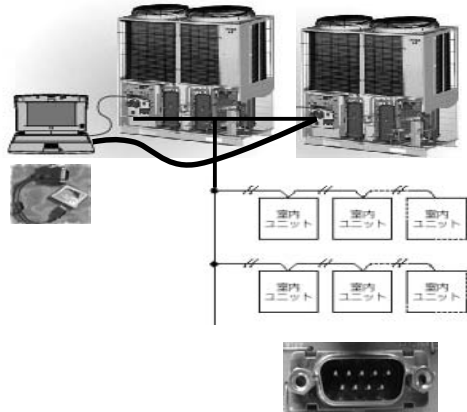
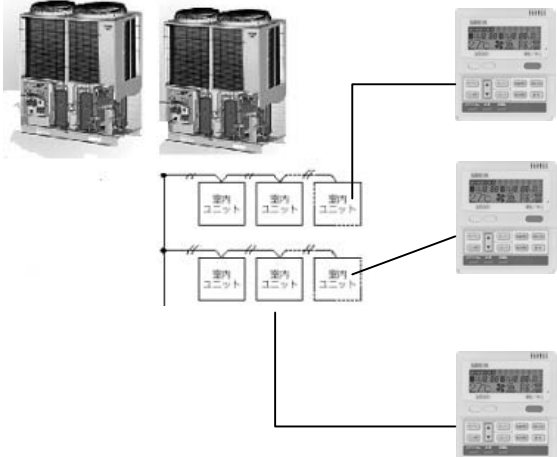

One property of MENTE PC includes a function to minimize test run time a Multi system that has plural indoor units and outdoor units in combination. At sites where test run must be performed for multiple number of system, the following tool can be used to perform test run in a short time.

Service tool includes personal computer, PDA and remote controller etc. Think over the method according to the site scale and test run time.

**Table 6.1 The list of service tools for test run**

	Outline	Main functions
MentePC and personal computer		<p>&lt;Check on site&gt;...① Check the data of main unit, sub unit and indoor units on the personal computer screen. ② Manually input the data into the standard data sheet.</p> <p>&lt;Data saving&gt; ...① Save the data of each sampling time. ② Save in HD of the personal computer.</p> <p>&lt;Standard data sheet input&gt;...① Automatic input from the saved file. ② Use test run report making tool.</p> <p><b>&lt;RS232C cross cable&gt;</b></p> <ul style="list-style-type: none"> <li>· There are pins on the outdoor unit base board, therefore there is 9-pin jack on the cable.</li> <li>· Carefully check the pins number of jack on the personal computer. There is even 25-pin jack on some models.</li> </ul>
Remote controller and 7 segment display		<p>&lt;Check on site&gt;...① Check the data of main unit, sub unit and indoor unit on the display of remote controller of each indoor unit and 7 segment display of outdoor units. ② Manually input the data into the standard data sheet.</p> <p>&lt;Data saving&gt; ...① Manually input the data into the standard data sheet.</p> <p>&lt;Standard data sheet input&gt;...① Manually input the data into the standard data sheet in EXCEL format.</p>

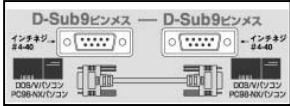
**Table 6.2 Specifications of necessary equipment for MentePC measurement**

	Maker·Product name·Product No.	Overview·Function·Purpose	Product picture
1	<Maker name: various computer makers > <Product name: omitted> <Product No.: omitted >	<Notebook PC> ① Specification: WindowsXP. Windows2000 WindowsMe · Windows98	
2	< Maker name: I / O DATA company> <Product name: 256MB SD memory card> <Product No.: PCSD-T256M>	<SD memory> ① Memory for personal computer installation ② There are a variety of capacities. Please choose the memory of appropriate capacity.	
3	<Maker name: IBS Japan (ELAN company) > <Product name: 2-port RS232C serial card> <Product No.: CF332>	<2-port RS232C serial card> ① Connect to the slot of personal computer ② Connect 2-channel RS232C cable from a slot ③ Driver software is provided ④ Accessory RS232C cable (10cm) is provided	
4	Maker name: Socket communication company (CF Co., Ltd.) Product name: CF serial card (1-port) Product No.: SL2700-096	<1-port RS232C serial card> ① Connect to the slot of personal computer ② Connect 1-channel RS232C cable from a slot ③ Driver software is provided ④ Accessory RS232C cable (10cm) is provided	
5	<Maker name: ELECOM company> <Product name: serial reverse cable (D-Sub9pinJack-D-Sub9pinJack)> <Product No.: C232R-930(3m)>	< serial reverse cable > ① D-Sub9pin jack-D-Sub9pin jack ② Various lengths are available	 
6	<Maker name: NTT DOCOMO company> <Product name: @FreeD corresponding communication card> <Product No.: P-in Free 1S> <Specification: (Japanese Version) Corresponding type WindowsXP·Windows2000Professional·WindowsMe·Windows98·WindowsCE*6 PC card:>	<Communication card> ① Applicable to both personal computer ② 64K / 32K communication card ③ The communication card can be installed on notebook computer by accessory PC card adaptor ④ CFcard:CF + and Compact Flash Specification Revision 1.4 or higher PC card:PC Card Standard 95 or higher	

## 1.2.4 Installation check

Before power is turned on, check to be sure that construction is properly proceeding by listening (partial check). The check is to prevent malfunction from happening during test run or after test run.

### 1.2.4.1 Check the use restrictions related to equipment design (KX4 8 horsepower or more)

· Usually check by listening or condition investigation, and put forward request for correction to construction workers.

No	Item	Standard	Result	Measure	Date
1	Number of connectable indoor units	① Refer to the following Note (1)		Add or separate indoor units	
2	Capacity of connectable indoor units	Indoor unit capacity $\leq$ outdoor unit capacity $\times$ 0.5 ~ 1.3		The same as above	
3	<b>Refrigerant pipe length limits</b>	① 1 Main pipe $\leq$ 130m ② 2 Branch pipe (First branch pipe~ indoor unit) $\leq$ 40m ③ 3 Actual length $\leq$ 160m ④ 4 Total length is less than 510m		Make correction to keep the length within restricted range	
4	<b>Height difference between indoor unit and outdoor unit</b>	① Upper outdoor unit: $\leq$ 50m 5 Lower outdoor unit: $\leq$ 40m		The same as above	
5	Height difference between indoor units	① $\leq$ 5m		The same as above	
6	<b>Distance between main unit pipes and sub unit pipes</b>	① Oil equalizing pipe $\leq$ 10m ② From pipe header section to each outdoor unit $\leq$ 5m		The same as above	
7	Installation space (indoor / outdoor units )	① Please refer to technical information			

Notes (1) Put forward request for all the above correction items to installers or dealers.

(2) For detailed information, please refer to KX4 construction check sheet (Page 632).

(3) Please be aware that the number of connectable indoor units will vary with the capacity of outdoor units. (Page 89)

Outdoor unit capacity	Number of connectable indoor units		
224	1 ~ 13 units	615	2 ~ 36 units
280	1 ~ 16 units	680	2 ~ 40 units
335	1 ~ 20 units	735	2 ~ 43 units
400	1 ~ 23 units	800	2 ~ 47 units
450	1 ~ 26 units	850 ~ 1065	2 ~ 48 units
504	1 ~ 29 units	1130 ~ 1360	3 ~ 48 units
560	1 ~ 33 units		

### 1.2.4.2 Check related to installation

· Usually check by listening, and put forward request for correction to construction workers.

No	Item	Standard	Result	Measure <sup>(1)</sup>	Date
1	Power supply breaker capacity	① Capacity recorded in the information (too high $\Rightarrow$ effective protection is impossible) ② With leakage breaker (INV unit should correspond to INV)		Make correction according to the records on the left.	
2	Field wiring terminal treatment	① Use terminal to be connected to terminal block.		Make correction according to the records on the left.	
3	<b>Signal wires and power supply wires are paralleled</b>	① Distance of 0.5m must be kept (Binding of signal wires / power supply wires: should not exceed 10m) ② Coaxial cables should not be used for signal wires / power supply wires		Make correction according to the records on the left.	

4	<b>Are signal wires and power supply wires mixed or not?</b>	① Resistance between terminal A ~ B (Ω) = $9100 \div (\text{number of indoor units} + \text{outdoor units} + \text{SLA units})$		<b>Make correction before power is turned on.</b>	
5	<b>Refrigerant piping material</b>	① Is the size proper (Please refer to related information)? ② Is the <b>quality of used branch pipe good</b> or is the setting method proper?		Make correction according to the records on the left.	
6	Is oil equalizing pipe connected?	① Connection must be made between main units ↔ sub units		The same as above	
7	Is air-tightness test conducted?	① Required pressure R22 = 2.94MPa R407C = 3.23MPa R410A = 4.15MPa		Make correction according to the records on the left.	
8	<b>Vacuuming</b>	① Has vacuuming been performed for more than 60 minutes after 750mmHg was reached?		Make correction according to the records on the left.	
9	<b>Charge refrigerant</b>	① Has refrigerant amount been <b>calculated</b> ? ② Has refrigerant been <b>charged according to the calculated amount</b> ? ③ Has charged refrigerant amount been recorded on outdoor unit?		If not taken care of, make correction according to the records on the left.	
10	<b>Address</b> (indoor / outdoor unit)	① Check by equipment diagram ② Have the addresses of outdoor units, sub units been set?			
11	Check the drain water of indoor units	① Has drain water been checked?		If not checked, pay attention during test run.	

Note(1) For detailed information, please refer to KX4 installation check sheet (Page 699) .

### 1.2.5 Check before test run

Before test run, check the following items, and then perform test run. If test run is performed without checking the following items, the items cannot be checked during test run and malfunction may occur after delivery.

#### 1.2.5.1 Check whether signal wires are mixed the correct ones...check before power is turned on

- (1) Check that remote controller wires (X, Y, Z wire) or indoor power wire etc. are not mixed with the signal wire (ab wire). Ignoring the mixed wires during check will result in the burnout (burnout of super link communication circuit...in the same circuit zener diode or else are damaged) of control printed wiring board of plural number of indoor / outdoor units.
- (2) Check method of mixture
  - ① Measure resistance (Ω) between any "A, B" terminals in super link. (See the right picture)
  - ② If the resistance value approximately equals to the value of the following formula, no wires are mixed.

**Resistance value (Ω) =  $9100 \div (\text{number of units})$**

Note (1) So called number of units represents the sum of indoor units, outdoor units and SLA-2A is respectively counted as one unit)

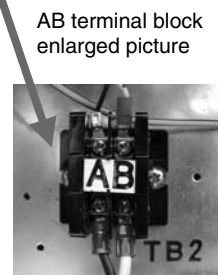
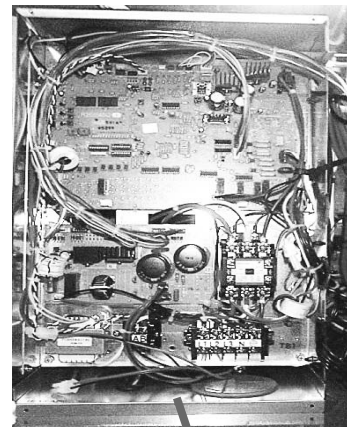

**Fig. 6.9 Measuring the resistance of super link communication wire and resistance between terminal A and B**

(Check whether signal wires are mixed)

### 1.2.5.2 Check to be sure that outdoor unit service valve has been opened... must check before operation

Before operation starts, test run operator should check to be sure that master/sub units' "service valves are fully open".

[If unit is operated with operation valve closed, low pressure protection device will be actuated, E49 will be displayed and operation will be stopped.]



**Fig. 6.10 Gas pipe Service valve (left figure) Liquid Service valve (right figure)**  
 <operate it with wrench> <operate it with hexagonal wrench>  
 <the valve shown above is fully closed> <the valve shown above is closed>



**Fig. 6.11 Operation valve Open marking**

- Write down the time and operator of service valve opening on the surface of outside board with magic pen.
- Write down the charged refrigerant amount on the inner surface of outside board

- Notes (1) During test run, if service valve is "closed", confirm with the installers whether vacuuming and air-tightness test have been completed and whether service valve has been service after charging refrigerant.
- (2) When service valve is fully opened, write down the time of opening service valve on the unit outside board with magic pen.

### 1.2.5.3 Check insulation, power supply voltage

(a) Check insulation

- Measure the insulation resistance with 500V insulation ohmmeter to make sure the insulation resistance is more than 1MΩ , and then turn on power.
  - If the insulation resistance is less than 1MΩ , confirm with the electrical construction company.
- (Note) Check the insulation under low voltage (less than 600V) with 500V range insulation ohmmeter.

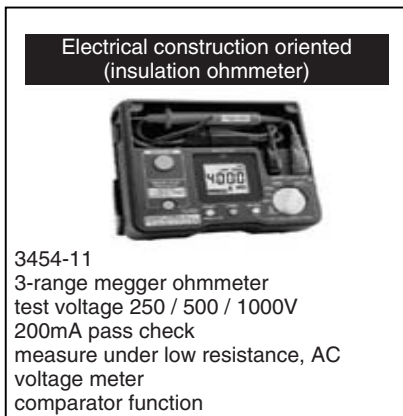

**Fig. 6.12 Measuring insulation and power supply voltage**

- check insulation with 500V insulation ohmmeter.
- Measure voltage with multimeter.

(b) Check power supply voltage (**check before operation**)

- Be sure to check power supply voltage before test run.
- Check when all units are operating, just in case.
- **Fill this measured value into the standard data sheet.**

### 1.2.5.4 Address check

- Turn on power and check in the sequence: outdoor unit → indoor unit. The method of checking without operating unit is as follows.

Method 1 - method of using MentePC (Indoor unit information acquisition version MentePC V3. 0.xls)

<Refer to MentePC instruction manual etc.>

Method 2 - method of using remote controller and 7 segment display

#### 1.2.5.4.1 Method of checking address by MentePC

<Check procedure>

- ① When power supply of outdoor unit is OFF, connect outdoor unit printed wiring board to personal computer with RS232C cable. (See Fig. 6.14, 6.15)
- ② Turn on power supply of outdoor unit and indoor unit. ⇒ During this period, if connected indoor unit and outdoor unit are faulty, error code of outdoor unit will be displayed and rough judgement can be made. Therefore, be sure to check during this period.
- ③ Check the number of connected indoor units by 7 segment display.

(Make the display KX4...DipSW 50; SW8 (5) SW9 (0))

**Refer to Fig. 6.13)**

- The number of connected indoor units should be the same as that shown in the figure.
- ⇒ If the numbers are not equal, please check the connection condition of ab wire connected to the unit or check the indoor unit printed wiring board. Be sure to correct it to proper condition.
- ⇒ When adopting this method, the work can be assigned to the personnel on site without a computer

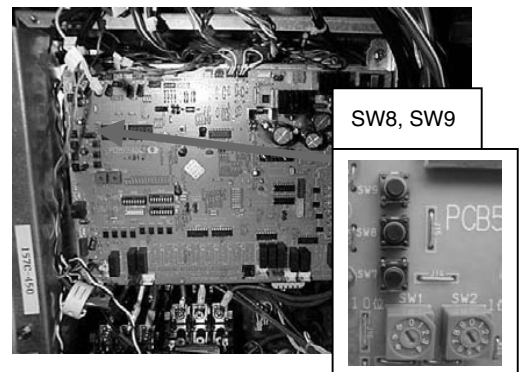
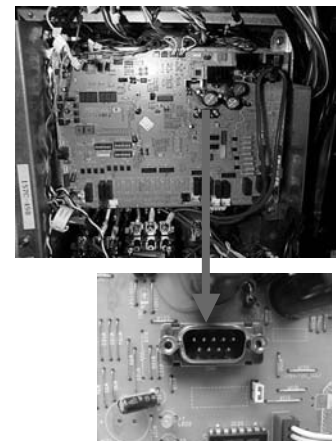

**Fig. 6.13 Outdoor base board (SW8, SW9)**

- ④ Check the number / address of combined indoor units.

- Get (Learn) the equipment design diagram to acquire a whole picture of air conditioner.

- ⑤ Connect the RS232C terminal of outdoor unit printed wiring board to computer, select all the indoor units combined with the outdoor unit and start these units, and then start MentePC. In case of sub unit, also connect RS232C to computer and start MentePC. In other words, connect 2-channel RS232C card to a computer or a PDA, and at the same time, start the MentePC program for main unit, indoor units and sub unit (See Fig. 6.15).



**Fig. 6.14 KX4 outdoor base board RS232C connection**

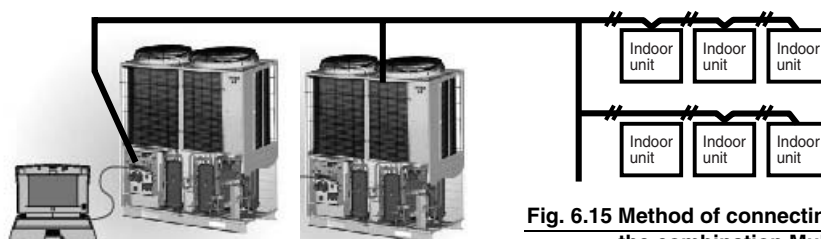

**Fig. 6.15 Method of connecting MentePC in the combination Multi system**

- ⑥ Start MentePC and select "Real time monitoring" mode as shown in Fig. 6.16. Click "START RECEIVING".

- ⑦ Start MentePC and acquire control information from outdoor unit and indoor unit. The addresses (See Fig. 6.17) of all the connected indoor units will be displayed in the "RAMDATA", "LOGDATA" worksheets of EXCEL. However, when the addresses of indoor units and outdoor units are changed, unit power supply should be reset. Later, restart MentePC, and click "START RECEIVING" (The address of the unit connected to super link is acquired at the time of "START RECEIVING". Later, the function will be turned to "NO RECEIVING". Pay attention to this.)

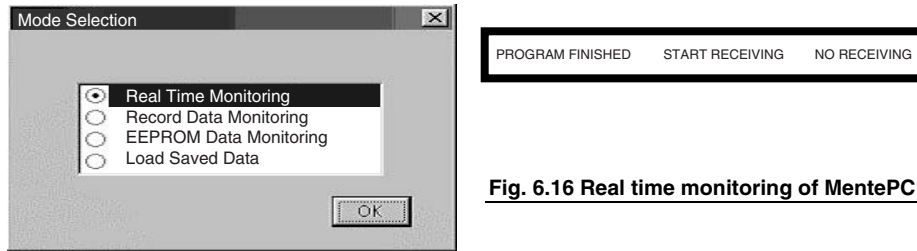

Fig. 6.16 Real time monitoring of MentePC

1			3	4	5	6	7	8
2			Soft version	KD9C243		Outdoor unit address	5	
3			PID	5D		Indoor unit 1		Indoor unit 2
4			Outdoor unit capacity	224		Indoor unit address	2	14
5			Power source frequency	60		Indoor unit capacity	56	56
6	No	CONTENT	RECEIVING DATA	CHANGE DATA	UNIT	CONTENT		
7	0	Error code	0	0				
8	1	Error unit address	0	0				
9	2	Operation mode	2	2		Cooling		
10	3	High pressure	12	0 Mpa				
11	4	Low pressure	6B	0.33 Mpa				
12	5	Heat exchanger temperature1 High	2D					
13	6	Heat exchanger temperature1 Low	8B	1.3 °C				
14	7	Heat exchanger temperature2 High	20					
15	8	Heat exchanger temperature2 Low	08	6 °C				
16	9	Heat exchanger temperature3 High	0					
17	10	Heat exchanger temperature3 Low	0	-35 °C				
18	11	Heat exchanger temperature4 High	0					
19	12	Heat exchanger temperature4 Low	0	-35 °C				
20	13	Discharge pipe temperature1	51	77 °C				
21	14	Discharge pipe temperature2	49	73 °C				

The addresses of all the connected indoor units are displayed here.

Fig. 6.17 "RAMDATA" worksheet display

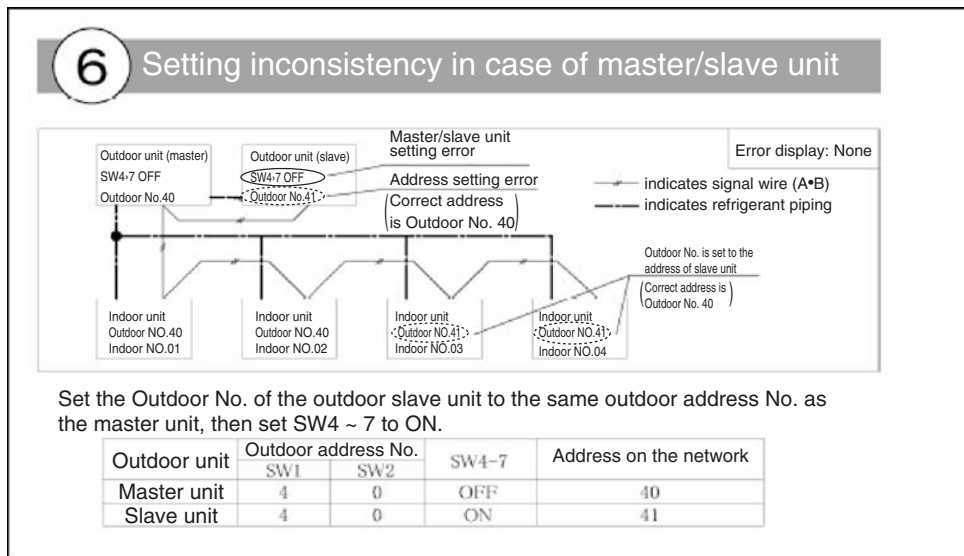

Fig. 6.18 Example of slave unit address setting error

(Please refer to "Multi KX4 series market fault examples collection", "Installation error prevention points collection", "Service information 4-358-S" etc.)

1.2.5.4.2 Method of checking address by remote controller and 7 segment display

- (1)The method is applicable to non-combined Multi system used on small applications.
- (2)This is the method of checking operation data by 7 segment display of outdoor unit and remote controller of each indoor unit.

<Procedure>

- ① Turn on the power ⇒ During this period, if connected indoor unit and outdoor unit are faulty, error code of outdoor unit will be displayed and rough judgement can be made. Therefore, be sure to check during this period.
- ② Check the number of connected indoor units by 7 segment display.



(Make the display KX4.....DipSW 50; SW8 (5) SW9 (0) **Refer to Fig. 6.13**)

· The number of connected indoor units should be the same as that shown in the blue print.

⇒If the numbers are not equal, please check the connection condition of ab wire connected to the indoor unit or check the indoor unit printed wiring board. Be sure to correct it to proper condition.

③ Check the address of outdoor unit by printed wiring board (Fig 6.19).

Check the address of each indoor unit by remote controller display (Fig 6.20).

⇒If the numbers do not match, please check the connection condition of ab wire connected to the indoor unit or check the indoor unit printed wiring board. Be sure to correct it to proper condition.

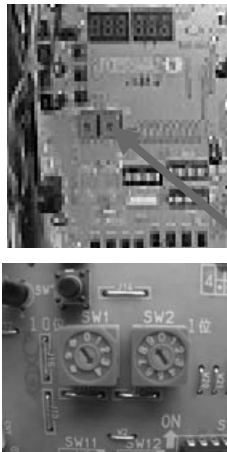

This SW (switch)

Press AIRCONDITIONER No. key , and the No. and addresses of connected indoor units will be displayed in turn.

**Fig. 6.19 Outdoor unit address check**



**Fig. 6.20 Method of checking address by remote controller**

## 1.2.6 Pairing (indoor / outdoor units combination) check

### 1.2.6.1 Purpose

- ① If refrigerant piping connection and address setting of indoor / outdoor units are made according to the equipment design diagram, the combination of indoor / outdoor units can be determined by either refrigerant piping connection or control signal.
- ② If piping construction workers and address setting operators are not informed of design changes during construction, **or address setting is wrong (1) etc., it is likely that pairing disparity will unknowingly occur.**
- ③ This is called pairing check.

### 1.2.6.2 Irregularities due to pairing disparity

The following severe faults may occur.

- ① Not cooling / not heating (due to faulty connection of piping and control wires among plural outdoor units.)
- ② In cooling operation: heat exchanger frozen ⇒ water leakage (it is almost impossible to protectly float switch.)
- ③ In heating operation: anomalous high pressure (E40).....varies with number of operating indoor units.
- ④ In cooling / heating operation: anomalous discharge temperature(E36).....varies with number of operating indoor units.
- ⑤ In cooling operation: liquid backflow results in compressor faults.....varies with number of operating indoor units.

Fig. 6.21 shows the concept of faulty connection between refrigerant piping and ab wire.

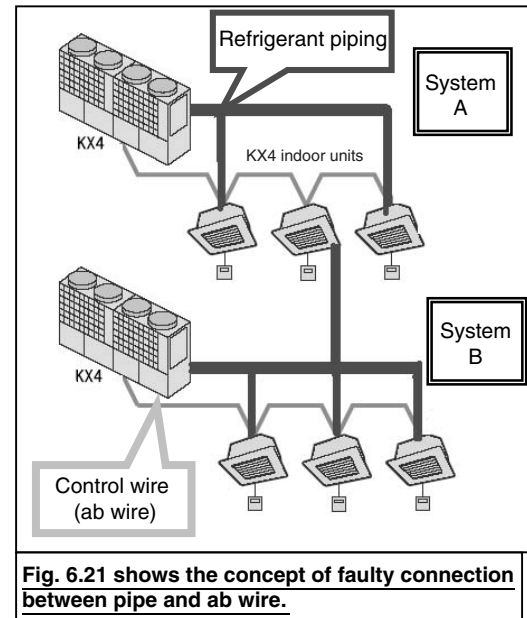

**Fig. 6.21 shows the concept of faulty connection between pipe and ab wire.**

<Examples of faulty connection between refrigerant piping and control wire (ab wire) in A, B system>

- When system A and B are operating simultaneously, because all indoor units are operating normally, no faulty refrigerant piping connection is found.
- However, when only system A is in test run, the indoor units with no pipes connected are not cooling or heating at all.
- When only system B is in test run, the indoor units with refrigerant flowing are controlled by system A. Because fan does not rotate and EEV does not open etc., liquid will abnormally flow back into compressor or low pressure is too low or else.

**Because this kind of faulty phenomenon exists, do not perform test run on the system until the pairing disparity is corrected.**

1.2.6.3 Check pairing by actual operation

1.2.6.3.1 Method of checking pairing by Mentepc

Here, explanation will be made on the combined Multi system (Main unit and sub unit, 2 outdoor units and plural indoor units) of KX4 series as an example.

[Operation procedure]

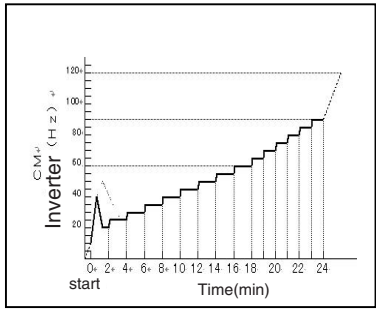
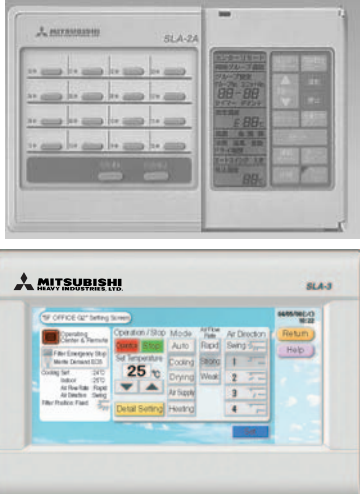
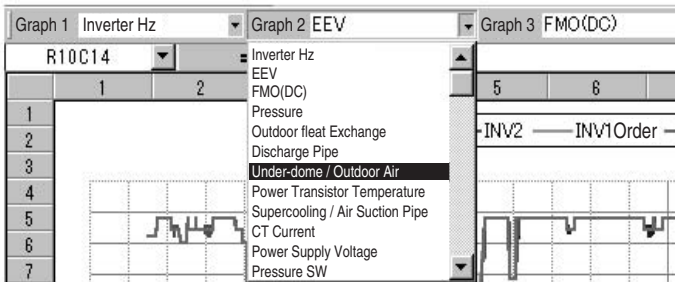
	Operation content	Remarks
<b>Start</b>	<p><b>&lt;Control before start&gt;</b>                      Pattern of starting varies with the control of crank case heater when power is turned on. Please pay attention to this.                      Moreover, turn on power 6 hours before starting, and increase oil temperature of compressor by crank case heater.</p> <p>① within 45 minutes after power is ON.....5Hz / 2 minutes, rises to 90Hz in 24 minutes.  <b>(See Fig. 6.22)</b></p> <p>② more than 45 minutes after power is ON.....5Hz / 1 minutes, rises to 90Hz in 15 minutes.                      It is unnecessary to do start control as described in P 399 or waits to start as in KX2.</p>	 <p><b>Fig. 6.22 Time and frequency (224HLX or more)</b></p>
<b>Pairing operation</b>	<p><b>Pairing operation</b></p> <p>① Set up personal computer beside the outdoor unit, and operate by each system.</p> <ul style="list-style-type: none"> <li>when indoor units are connected to remote controller, use the remote controller.</li> <li>when you are at the roof and it is impossible to operate by indoor unit remote controller, or remote controller is not connected, operate by center console SLA-2A or SLA-3-E (See Fig. 6.23).</li> </ul> <p>② Using Mentepc, check all the indoor units corresponding to operation mode to be sure that heat exchange temperature is dropping in cooling operation, and rising in heating operation <sup>(1)</sup>. Compared with the temperature under stopped condition, the temperature change in cooling operation is: 5 ~ 10°C                      In heating operation: 10 ~ 20°C.                      The temperature will vary a little with indoor unit capacity.                      Temperature change varies with compressor operation condition, and it takes several to 10 minutes.</p> <p>③ Check the rise and drop of heat exchange temperature of all the indoor units, turn SW5-1, 2 OFF, and stop operation.                      ⇒ After operation is stopped, check whether the heat exchange temperature of all the indoor units have changed to the temperature before operation (See Fig. 6.24).</p>	 <p><b>Fig. 6.23 Outline of SLA-2A-E (upper figure) and SLA-3-E (low figure)</b></p> <ul style="list-style-type: none"> <li>Refer to instruction manual for usage method</li> <li>Check the temperature change of the stopped outdoor unit, which is helpful for pairing check of other outdoor units in operation.</li> </ul>
	 <p><b>Figure 6.24 Check the graph of indoor unit heat exchange temperature by Mentepc</b>                      ("GRAPH worksheet")</p>	

<MentePC [Program operation method] > (See Fig. 6.25)

1. Open EXCEL file "MentePC\_V . .xls".
2. Macro execution selection window appears.  
Click "ENABLE MACRO".
3. Mode selection window appears. Select mode to be executed, and click "OK" button.
  - ① Real time monitoring  
: Display and save the current operation data in a cycle of 1 ~ 60 seconds.
  - ② Recording data monitoring  
: Display and save the data of 30 minutes before malfunction.
  - ③ EEPROM data monitoring  
: Display and save the data at the time of malfunction.
  - ④ Read saved data  
: Read the data saved in the above 3 modes, and display the data on the screen.
4. Then, selection window of setting file of each model appears.
  - Model selection file (Select model selection file according to each KX4 model)
  - RAM data\_LX8.xls
    - - KX4 (one compressor) outdoor unit (A224 ~ A335) setting file
  - RAM data\_LXC.xls
    - - KX4 (two compressors) outdoor unit (A335-K ~ A680) setting file
 Select above files.

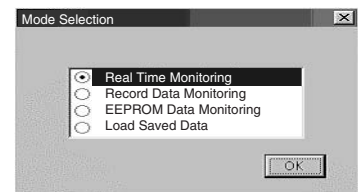

**Fig. 6.25 Setting screen of MentePC**

For detailed information, please refer to MentePC instruction manual.

1.2.6.3.2 Method of checking pairing by remote controller and 7 segment display

	Operation content	Remarks
Pairing operation	<p>&lt;Pairing operation&gt;</p> <ul style="list-style-type: none"> <li>Check the heat exchange temperature of all the object indoor units by "operation data display" of remote controller.</li> <li>Check the indoor units corresponding to operation mode to be sure that heat exchange temperature is dropping in cooling operation and rising in heating operation <sup>(1)</sup>.</li> <li>The temperature when operation is stopped change to 5 ~ 10 deg in cooling operation and 10 ~ 20 deg in heating operation.</li> <li>Check the above operation data by using appendix 5 Multi system standard data sheet (for new remote controller), or reading and writing from remote controller etc.</li> </ul> <p>&lt;Usage method of remote controller&gt;</p> <ol style="list-style-type: none"> <li>Press check switch (SW) ② Determine "operation data display" with set switch (SW)</li> <li>Determine indoor address (Indoor 01 etc.) with set switch (SW)</li> <li>"Reading data" is displayed, operation data being read from outdoor unit and indoor unit</li> <li>Press ▲ switch (SW), 01 cooling etc., then the items in table 3 will be displayed in turn.</li> </ol> <p>(Note) The displayed data will skip the value displayed for the first time and read the value displayed from the second scroll.</p>	<p>← This is very important for actual operation.</p>  <p><b>Fig. 6.26 Operation of new remote controller</b> (Operation data display)</p>

1.2.7 Unit evaluation by test run switch (SW)

1.2.7.1 Method of unit evaluation by MentePC

Operation	<p><b>Start operating the system on which pairing check has been completed.</b></p> <p>Operation method</p> <ol style="list-style-type: none"> <li>Outdoor unit Start cooling or heating operation by "test run switch (SW5-1, 2)" of main unit (See Fig. 6.27)</li> </ol> <p>Remarks</p> <ol style="list-style-type: none"> <li>If power is reset or else, start operation at least 3 minutes after power is ON.</li> <li>The test run Max. frequency of KX4 series is not stably 100Hz as KX2 series. The frequency is as shown in the right.</li> </ol> <ul style="list-style-type: none"> <li>Compressor frequency varies with cooling low pressure control operation (in cooling operation) and heating high pressure control operation (in heating operation).</li> </ul> <ol style="list-style-type: none"> <li>When test run is performed by remote controller, air flow rate should be set "high".</li> </ol>	<ol style="list-style-type: none"> <li><u>Cooling low pressure control</u> <u>Main unit, sub unit control value (MPa)</u> Low pressure 0.65 ~ 0.82MPa</li> <li><u>Heating high pressure control</u> <u>Main unit, sub unit control value (MPa)</u> All models 2.75MPa</li> </ol> <p><b>Fig. 6.27 Position of test run switch</b> •As shown in the left picture, SW5 is on the left, SW3 is on the right, and SW4 is at the lower position.</p>
-----------	--	--

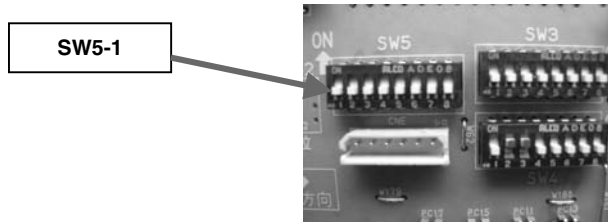

**Data items to be acquired and measuring method, points**

- (1) Items acquired from MentePC and measuring file
  - (a) Outdoor unit: compressor operation frequency / compressor current / high pressure / low pressure / discharge pipe temperature / compressor dome lower part temperature / heat exchanger temperature / expansion valve opening / subcool temperature / superheat temperature, for other detailed information, refer to the items on the standard data sheet. (Page 630 )
  - (b) Indoor units (acquire the following data of all indoor units)
    - Address, required frequency, expansion valve opening, heat exchange temperature, suction air temperature
    - Measure supply air temperature with thermometer if necessary.
- (Notes)
  - 1. On site, manually input into computer screen or standard data sheet to record and judge operation data.
  - 2. If faults or else are found when measuring operation data on site, correct the faults at first, and then measure operation data again.
- (2) In the "Real time monitoring " mode of new version MentePC, the data of all the indoor units connected to outdoor units are saved by Main unit's file, and sub unit's data saved by sub unit's file.
  - On site, fill data into the data sheet while observing the display, and check operation condition (Of course, if gas leakage or unit air circulation short circuit etc. occurs during this period, the trouble should be solved at first, and then measure the operation data again.)
- (3) The data finally provided for customer should be saved as measuring condition file. Use "Test run report making tool" of MentePC to read the data into the data sheet.

\* Data should be acquired quickly in order to continuously acquire data of indoor units before operation condition of outdoor unit changes (compressor frequency, actuation of protection control).



**Fig. 6.28 Segment display**

(upper SW9: tens digit  
middle SW8: units digit)  
(Do not touch the lower SW7)

Data measuring

**KX4 Multi Series Operation Data Sheet (Master/Slave Outdoor Unit & Indoor Unit) <for submission to entrusted construction unit>**

Place of delivery		System No.		Date of test run			Weather			Pressure in change		Construction No.		
System No.		Date of test run			Weather			Pressure in change		Construction No.		Construction No.		
Outdoor unit data														
Outdoor model (Outdoor unit No.)	Operation mode	Indoor voltage (V)	Outdoor voltage (V)	High pressure PSH (MPa)	Low pressure PSL (MPa)	Discharge pipe sensor C	Compressor current (A)	Compressor current (A)	Compressor current (A)	Compressor current (A)	Compressor current (A)	Compressor current (A)	Compressor current (A)	Compressor current (A)
Standard	Cooling	258	418	8.5	1.2	11.6	11.8							
	Heating	260	808											
	Lower limit	267	842											
	Upper limit													
Indoor unit data														
Refrigerant name	Refrigerant amount (kg)	Unit No.	Indoor unit model	Address	Demand (Hz)	Expansion valve opening (EEV)	Suction temperature (°C)	Heat exchange sensor temperature (°C)	Supply air temperature (°C)	Return air temperature (°C)	Heat exchanger sensor temperature (°C)	Blow-out temperature (°C)	Empress-km difference between suction and discharge heat exchanger C	
410	200	46	FDCP400HLX(14HP)	46	258	200	27.0	12.1	13.4	14.8	14.9	14.8	14.9	
			FDCP504HLX(18HP)	45	260	200	27.0	11.8	12.3	14.0	15.8	14.3	15.9	
			FDCP504HLX(18HP)	46	260	200	27.0	11.1	11.2	13.9	12.4	14.8	15.4	
			FDCP504HLX(18HP)	47	260	200	27.0	12.4	12.2	14.8	14.8	14.8	15.4	
			FDCP504HLX(18HP)	48	260	200	27.0	11.1	11.2	13.9	12.4	14.8	15.4	
			FDCP504HLX(18HP)	49	260	200	27.0	12.4	12.2	14.8	14.8	14.8	15.4	
			FDCP504HLX(18HP)	50	260	200	27.0	11.1	11.2	13.9	12.4	14.8	15.4	
			FDCP504HLX(18HP)	51	260	200	27.0	12.4	12.2	14.8	14.8	14.8	15.4	
			FDCP504HLX(18HP)	52	260	200	27.0	11.1	11.2	13.9	12.4	14.8	15.4	
			FDCP504HLX(18HP)	53	260	200	27.0	12.4	12.2	14.8	14.8	14.8	15.4	
			FDCP504HLX(18HP)	54	260	200	27.0	11.1	11.2	13.9	12.4	14.8	15.4	
			FDCP504HLX(18HP)	55	260	200	27.0	12.4	12.2	14.8	14.8	14.8	15.4	
			FDCP504HLX(18HP)	56	260	200	27.0	11.1	11.2	13.9	12.4	14.8	15.4	
			FDCP504HLX(18HP)	57	260	200	27.0	12.4	12.2	14.8	14.8	14.8	15.4	
			FDCP504HLX(18HP)	58	260	200	27.0	11.1	11.2	13.9	12.4	14.8	15.4	
			FDCP504HLX(18HP)	59	260	200	27.0	12.4	12.2	14.8	14.8	14.8	15.4	
			FDCP504HLX(18HP)	60	260	200	27.0	11.1	11.2	13.9	12.4	14.8	15.4	
			FDCP504HLX(18HP)	61	260	200	27.0	12.4	12.2	14.8	14.8	14.8	15.4	
			FDCP504HLX(18HP)	62	260	200	27.0	11.1	11.2	13.9	12.4	14.8	15.4	
			FDCP504HLX(18HP)	63	260	200	27.0	12.4	12.2	14.8	14.8	14.8	15.4	
			FDCP504HLX(18HP)	64	260	200	27.0	11.1	11.2	13.9	12.4	14.8	15.4	
			FDCP504HLX(18HP)	65	260	200	27.0	12.4	12.2	14.8	14.8	14.8	15.4	
			FDCP504HLX(18HP)	66	260	200	27.0	11.1	11.2	13.9	12.4	14.8	15.4	
			FDCP504HLX(18HP)	67	260	200	27.0	12.4	12.2	14.8	14.8	14.8	15.4	
			FDCP504HLX(18HP)	68	260	200	27.0	11.1	11.2	13.9	12.4	14.8	15.4	
			FDCP504HLX(18HP)	69	260	200	27.0	12.4	12.2	14.8	14.8	14.8	15.4	
			FDCP504HLX(18HP)	70	260	200	27.0	11.1	11.2	13.9	12.4	14.8	15.4	
			FDCP504HLX(18HP)	71	260	200	27.0	12.4	12.2	14.8	14.8	14.8	15.4	
			FDCP504HLX(18HP)	72	260	200	27.0	11.1	11.2	13.9	12.4	14.8	15.4	
			FDCP504HLX(18HP)	73	260	200	27.0	12.4	12.2	14.8	14.8	14.8	15.4	
			FDCP504HLX(18HP)	74	260	200	27.0	11.1	11.2	13.9	12.4	14.8	15.4	
			FDCP504HLX(18HP)	75	260	200	27.0	12.4	12.2	14.8	14.8	14.8	15.4	
			FDCP504HLX(18HP)	76	260	200	27.0	11.1	11.2	13.9	12.4	14.8	15.4	
			FDCP504HLX(18HP)	77	260	200	27.0	12.4	12.2	14.8	14.8	14.8	15.4	
			FDCP504HLX(18HP)	78	260	200	27.0	11.1	11.2	13.9	12.4	14.8	15.4	
			FDCP504HLX(18HP)	79	260	200	27.0	12.4	12.2	14.8	14.8	14.8	15.4	
			FDCP504HLX(18HP)	80	260	200	27.0	11.1	11.2	13.9	12.4	14.8	15.4	

Standard value  
<Outdoor side>, voltage, high pressure, low pressure, discharge temperature, current  
<Indoor side>, voltage, difference between return air temperature and heat exchange temperature

**Fig. 6.29 KX Multi system standard data sheet**

- ① Data configuration: the left half is about outdoor unit, and the right half is about indoor unit. Operation data standard value is set on the top of data items.
- If the data is within the standard value range, operation is usually normal.

Service

**Operation data check / timing and recording of measurement**

- (1) After measurement starts, observe the computer screen. When pressure reaches target value (low pressure 0.8MPa in cooling operation; high pressure 2.75MPa in heating operation), check to be sure that discharge temperature, current value, difference between indoor unit return air temperature and supply air temperature are within standard range, and acquire data file (stop MentePC program).
  - Summarize the following data files by MentePC.  
Outdoor unit (Main unit) outdoor unit (sub unit)  
Indoor units (1 ~ 16 units) indoor units (17 ~ 32 units)
  - The file is necessary for batch processing automatic input into standard data sheet.
- (2) The example shown in Fig. 6.30 will vary with operation starting condition, however, pressure will reach target value in about 20 ~ 30 minutes.

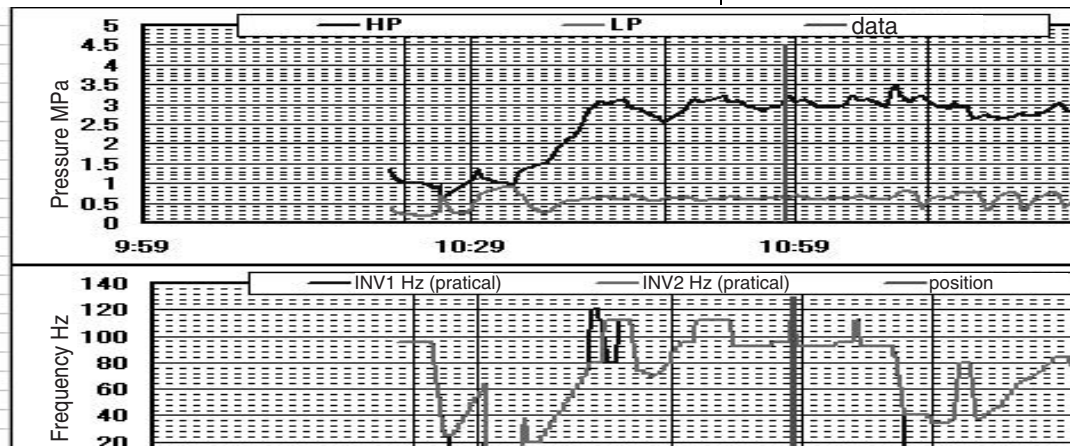

**Fig. 6.30 Example of MentePC measuring graph**

Operation data check

- (3) The above graph is about test run of one system. When there are plural computers, make preparations, checking and recording for other system before pressure reaches target value in order to check all the systems in full scale.
- (4) Internal check of outdoor units (mainly check by looking and listening)  
When recording data, check the following items.
  - ① Whether refrigerant pipes and capillary tubes are in contact → if there are any faults, solve them.
  - ② Whether the binding of refrigerant pipes and capillary tubes (countermeasures against stress, contact prevention) is loose or has fallen off → if there are any faults, solve them.
  - ③ Whether the wirings are too tight or in contact with pipes → if there are any faults, solve them.
  - ④ Check the measured value of sensor (discharge pipe, compressor dome lower part, current).

\* **Actuation of protection control:** protection control is actuated normally with overload  
· **high pressure control, current control, discharge temperature control etc.**

\* When protection control is actuated, if air condition actuates protection control but overload is not reached (when temperature exceeds cooling / heating rated condition, protection control may be actuated), check the following items.

- ① indoor / outdoor unit: air circulation short circuit or not
- ② FDUM, FDU, FDR: no setting in relevance to ducts → air flow rate is insufficient
- ③ wrong pairing or address
- ④ insufficient refrigerant (gas leakage, remaining in stopped units or heat accumulator)
- ⑤ whether sensor (Td sensor, current sensor, pressure switch) is faulty → compare the measured value of sensor with actually measured value

### 1.2.7.2 Evaluate by remote controller and 7 segment display

(1) Operation by remote controller of indoor units and 7 segment display of outdoor units.

	Operation content	Remarks
Operation method	<p>&lt;Points of operation by operation data display function of remote controller and outdoor 7 segment display function&gt; [Operation method]</p> <ol style="list-style-type: none"> <li>Operate "<b>Test run switch(SW5-1, 2)</b>" of Main unit of outdoor unit to start cooling or heating operation (See Fig.6.27)</li> <li>When measuring is started, check remote controller and 7 segment display and first check that pressures are at target values (in cooling low pressure at 0.8 MPa, in heating high pressure at 2.75MPa) then make sure that discharge temperature or current value, indoor unit suction temperature or difference between air return temperature and air supply temperature are within standard range, and then fill the data into data sheet.</li> </ol>	
Data measuring	<p>&lt; Data measuring &gt;</p> <ol style="list-style-type: none"> <li>At first, skip the operation data displayed by remote controller on the indoor unit side and remote controller side (Sometimes the previous data will remain, therefore this procedure must be carried out.)</li> <li>Read the operation data on the remote controller, and record the data into the attached "KX4 Multi system standard data sheet (for remote controller)".</li> <li>Then, check high pressure or low pressure, current, discharge temperature or other data items by 7 segment display at outdoor unit side, and make sure these data items correspond to the remote controller data.</li> <li>Check the same data items on other meters (Manifold gauge, contact thermometer, clamp meter etc.), and make sure these data are close to remote controller or 7 segment display value.</li> </ol>	
Data judgement	<p>&lt; Data judgement &gt;</p> <ul style="list-style-type: none"> <li>Make judgement of the test run result according to the data recorded on data sheet and refer to the above judgement standard and standard operation data (Page 598 )</li> </ul>	
	<p>&lt;Precautions after test run&gt; Carry out the same procedure in "7.1 Method of evaluating unit by MentePC".</p>	

(2) Remote controller "operation data" display function

- There is a new remote controller of new specification in KX4 series connecting 16 indoor units simultaneously at maximum with XYZ wire. Thus, the operation data of **all the indoor units** connected to the same super link will be displayed in real time on the LCD of one remote controller.

• **Table 6.3 The list of "Operation data" displayed by remote controller**

No.	Data items of indoor units	Display range	No.	Data items of indoor units	Display range
01	Operation mode	Cooling / heating / drying / air supply	21	Outdoor air temperature	-20 ~ (°C)
02	Set temperature	18 ~ 30 (°C)	22	Outdoor unit heat exchanger temperature (Main unit)	-20 ~ (°C)
03	Air return temperature	0°C or more	23	Outdoor unit heat exchanger temperature (Main unit)	-20 ~ (°C)
04	Inner heat exchanger temperature 1	The same as above	24	Operation Hz (Main unit CM1)	0 ~ 100 (Hz)
05	Inner heat exchanger temperature 2	The same as above	25	High pressure	0.0 ~ (MPa)
06	Inner heat exchanger temperature 3		26	Low pressure	0.00 ~ (MPa)
07	Indoor fan speed		27	Discharge pipe temperature (Main unit CM1)	30 ~ (°C)
08	Required frequency		28	Compressor dome lower part temperature (Main unit CM1)	-20 ~ (°C)
09	Response frequency		29	CT current (Main unit CM1)	0 ~ (A)
10	Expansion valve opening	0 ~ 480 (pulse)	37	Expansion valve opening 1 (Main unit)	0 ~ 500 (pulse)



**· Table 6.3 The list of "Operation data" displayed by remote controller**

11	Indoor operation time	0 ~ 25500h	38	Expansion valve opening 2 (Main unit)	0 ~ 500 (pulse)
----	-----------------------	------------	----	--	-----------------

Notes (1) No.: displayed on the right side on the top of remote controller LCD, **representing the displayed data items.**

(2) Data items and display range: Dot display on the bottom of remote controller LCD displays the content in the above table;

Display the data with unit within the range of the above table on the right.

**(3) Procedure of displaying data on the remote controller**

The following operation can display data whether the air conditioner runs or stops, please master common operation method.

**Procedure**

- ① Press "CHECK" button.  
·"OPERATION DATA DISPLAY" is displayed automatically **after several seconds.**
- ② When "OPERATION DATA DISPLAY" is displayed, press "SET" button.  
·**The minimum address of indoor unit** like "INDOOR 00" is **flickers.**
- ③ Use button to choose the address of the desired indoor unit, then press "SET" button.
  - The address is changed from flickering to constant display, and after 2 seconds, the display becomes "DATA BEING READ".
  - approx. 30 seconds later, the display switches to data. (Skip the initial display value, start to use from the second display of data.)
- ④ Referring to the above table, use "  " button to choose **desired data item** (01 ~ 38).  
(If not operated, the data will be displayed continuously.)  
(Note) Data of outdoor unit: choose any indoor unit in signal combination with the outdoor unit whose data you want to check. If any data number (21 ~ ) of the outdoor unit is input according to the above table, data of the outdoor unit will be displayed.  
(Data of outdoor unit cannot be displayed by merely choosing any outdoor unit through address selection)
- ⑤ When changing to other outdoor unit, if the "AIR CON No" button is pressed, the display will be changed to indoor unit address selection.  
(Notes) 1. In the above operation, if you want to return to the former set screen, press "RESET" button. It becomes the set screen. If pressed continuously, the operation data display will be terminated, and it returns to common display (operation / stop).  
2. When clearing operation data, even not doing the above operation, if the OPERATION STOP button is pressed, the screen can immediately return to normal display (operation / stop). (In this case, the operating (stopping) unit cannot be stopped (operated))

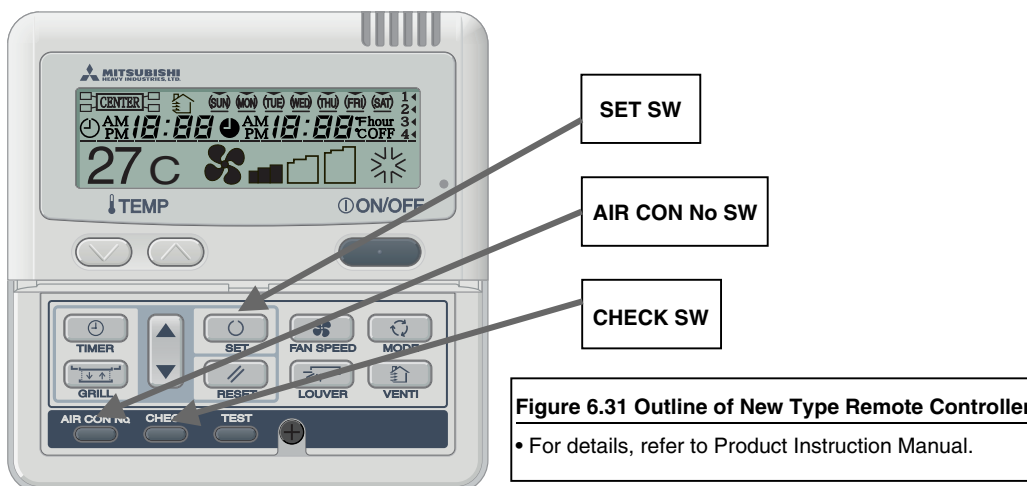

(4) Operation of outdoor 7-segment display and list of values

By pressing SW8, SW9 as shown in Figure 6.32, the measured data can be displayed.

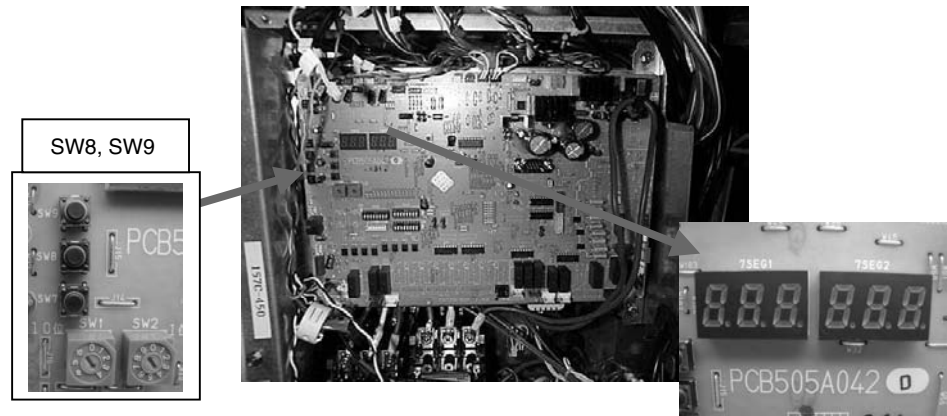

Figure 6.32 Outdoor Board (7-segment display)

Table 6.4 List of "Operation Data" according to 7-segment display of outdoor unit

Code No.	Display Content	Data Display Range	Min. Unit
—	Anomaly Code Pump Down Check Mode Outdoor Unit Setting	—	—
00	CM1 Operation Frequency	0 ~ 130	1Hz
01	CM2 Operation Frequency	0 ~ 130	1Hz
02	Tho-A Outdoor Air Temperature	L, -20 ~ 43	1°C
03	Tho-R1 Heat Exchanger Temperature 1 (Outlet-Front)	L, -25 ~ 73	1°C
04	Tho-R2 Heat Exchanger Temperature 2 (Outlet-Rear)	L, -25 ~ 73	1°C
05	Tho-R3 Heat Exchanger Temperature 3 (Outlet-Front)	L, -25 ~ 73	1°C
06	Tho-R4 Heat Exchanger Temperature 4 (Outlet-Rear)	L, -25 ~ 73	1°C
07	Tho-D1 Discharge Pipe Temperature (CM1)	L, 31 ~ 136	1°C
08	Tho-D2 Discharge Pipe Temperature (CM2)	L, 31 ~ 136	1°C
09	Backup		
10	Tho-C1 Dome Lower Part Temperature (CM1)	L, 5 ~ 90	1°C
11	Tho-C2 Dome Lower Part Temperature (CM2)	L, 5 ~ 90	1°C
12	Tho-P1 Power Transformer Temperature (CM1)	L, 31 ~ 136	1°C
13	Tho-P2 Power Transformer Temperature (CM2)	L, 31 ~ 136	1°C
14	Tho-SC Sub-cool Coil Temperature 1	L, 18 ~ 73	1°C
15	Tho-H Sub-cool Coil Temperature 2	L, -25 ~ 73	1°C
16	Tho-S Suction Pipe Temperature	L, -25 ~ 73	1°C
17	Cooling Sub-cool Temperature	0 ~ 50	1°C
18	Suction Superheat Temperature	0 ~ 50	1°C
19	Sub-cool Coil Superheat Temperature	0 ~ 50	1°C
20	CT1 (CM1) Current	0 ~ 70	1A
21	CT2 (CM2) Current	0 ~ 70	1A
22	EEVH1 Opening of Expansion Valve for Heating	0 ~ 500	1 pulse
23	EEVH2 Opening of Expansion Valve for Heating	0 ~ 500	1 pulse
24	EEVSC Opening of Expansion Valve for Sub-cool Coil	0 ~ 500	1 pulse
25	Backup		
26	FM01 Rotation Speed	0 ~ 1500	10min <sup>-1</sup>
27	FM02 Rotation Speed	0 ~ 1500	10min <sup>-1</sup>
28	PSH High Pressure Sensor	0 ~ 5.00	0.01MPa
29	PSL Low Pressure Sensor	0 ~ 2.00	0.01MPa

## 1.2.8 Submission to Entrusted Construction Unit

Summarize the results of test run into a test run report and submit it to the entrusted construction unit.



1.2.9.2 KX4 Multi Standard Data Sheet (for new remote controller)

Attached Table 6.6 KX4 Multi Standard Data Sheet (for remote controller)

5HP Multi Remote Control data sheet (5馬力マルチ リモコンデータ表)												
RMS he	Customer (客先)	Date of delivery (納入日時)	Filled by (記入者)									
Indoor unit (室内)		Model (機種);	Manufacture No.									
		Model (機種);	Manufacture No.									
		Model (機種);	Manufacture No.									
		Model (機種);	Manufacture No.									
		Model (機種);	Manufacture No.									
		Model (機種);	Manufacture No.									
		Model (機種);	Manufacture No.									
		Model (機種);	Manufacture No.									
Outdoor unit (室外)		Model (機種);	Manufacture No.									
Content of claim involving (運転状況含むクレーム内容)												
Please input data into the blue cells. Data in unspecified cells cannot be used for diagnosis.												
No.	Data item (データ項目)	Error data (エラーデータ) Yes [E] / No	Operation data (運転データ)									
			Indoor unit 00	Indoor unit 01	Indoor unit 02	Indoor unit 03	Indoor unit 04	Indoor unit 05	Indoor unit 06	Indoor unit 07		
		Model										
		Time										
Indoor unit side	01 運転モード	Operation mode	-									
	02 リモコン設定温度	Temperature setting	℃									
	03 吸込温度	Return air temperature	℃									
	04 熱交温度1	Heat exchanger temperature 1	℃									
	05 熱交温度2	Heat exchanger temperature 2	℃									
	06 熱交温度3	Heat exchanger temperature 3	℃									
	07 ファン速度	Fan speed	Step									
	08 要求周波数	Required frequency	Hz									
	09 アンサー周波数	Answer frequency	Hz									
	10 膨張弁開度	Expansion valve opening degree Pulse	Pulse									
	11 室内運転時間	Indoor units operation time	h									
- 吹出温度	Supply Air temperature	℃										
Outdoor unit side	21 外気温度	Outdoor temperature	℃									
	22 熱交温度1	Heat exchanger temperature 1	℃									
	23 熱交温度2	Heat exchanger temperature 2	℃									
	24 運転HZ	Operation frequency	Hz									
	25 高圧圧力	High pressure	MPa									
	26 低圧圧力	Low pressure	MPa									
	27 吐出管温度	Discharge pipe temperature	℃									
	28 ドーム下温度	Under-dome temperature	℃									
	29 CT電流	CT current	A									
	31 ファン速度	Fan speed	Step									
	32 静音モード	Silent mode	-	Valid / Not Valid	Valid / Not Valid	Valid / Not Valid	Valid / Not Valid	Valid / Not Valid	Valid / Not Valid	Valid / Not Valid	Valid / Not Valid	
	33 63H2	63H2	-	ON/OFF	ON/OFF	ON/OFF	ON/OFF	ON/OFF	ON/OFF	ON/OFF	ON/OFF	
	34 63H1	63H1	-	ON/OFF	ON/OFF	ON/OFF	ON/OFF	ON/OFF	ON/OFF	ON/OFF	ON/OFF	
	35 デフロスト	Defrost	-	ON/OFF	ON/OFF	ON/OFF	ON/OFF	ON/OFF	ON/OFF	ON/OFF	ON/OFF	
	36 コンプレッサ運転時間	Compressor operation time	h									
	37 膨張弁開度1	Expansion valve opening degree1	Pulse									
	38 膨張弁開度2	Expansion valve opening degree2	Pulse									

Service

1.2.9.3 KX4 construction checklist

Material name, system name		Check person: affiliation, name	Date of creation		
Please fill in model and unit No					
Classifica-tion	Check item	Criterion	Result	Fill in the results or numerical values	Date of implementa-tion
1. Indoor side	① Is the installation space within the restricted range? (inside the vent space, ceiling)	Check through technical materials (reaching distance, short circuit, work table size)			
	② Is the installation location (location of suspended bolt) consistent with that of ceiling opening?	Conformity of position			
	Is the suspended bolt of specified size?	Check through technical materials (M10 or M8)			
	③ Have measures been taken to prevent the welding spatter during building construction?	Stay packed before installation. Protect with paper board after suspension			
	④ Is the air condition inside the ceiling within the limitation range? (to prevent dew formation)	Dew point temperature below 28°C, relative humidity below 80%			
	⑤ During construction, have measures been taken to eliminate gap in the joint of piping heat insulation material?	Joint of heat insulation material, flare nut must be sealed securely. Heat insulation material shall not be pressed to deformation			
	⑥ During construction, is the drain horizontal flow piping inclined downward?	Appropriate slope is 1 / 50 ~ 1 / 100 Housing piping is prohibited			
	⑦ Is there any trap along the drain vertical piping?	No trap should be set for units with external static pressure = 0Pa (except for ducted units).			
	⑨ Is the connection with collective drain piping made from above the collective pipe?	Connect from above the collective piping			
	⑩ For the unit using drain pump (built-in, option), is the vertical length of its drain piping appropriate?	Within 600 ~ 750mm from the ceiling port or under the unit (FDR)			
	⑪ For the unit using drain pump, is the field piping vertical near the unit?	Vertical in the vicinity within 295 ~ 325mm			
	⑫ For the unit using drain pump, is the standard accessory drain hose used?	Standard accessory drain hose must be used			
	⑬ Is the standard accessory drain hose fastened with the accessory metal strip?	Use of adhesive is prohibited			
	⑭ Does the drain piping absorb the smell of the gutter?	Drain piping outlet is located where no smell is generated (inducted into rain gutter, etc)			
	⑮ Is the drain piping heat insulated? (to prevent dew formation)	Implement the construction of heat insulation material (approx. 5°C drain water flows)			
	⑯ Is the drain piping supported at a certain interval?	Support at the interval of 1m for PVC pipe and 2m for copper pipe			
	⑰ Are the number of connected indoor units and total connected capacity appropriate?	Total connected capacity is 50 ~ 130% that of outdoor unit		<b>Indoor unit capacity comparison:</b> %	

2. Outdoor side	① Is the installation space within the restricted range? (no blown-in air (short circuit))	Check through technical materials. Difference between outdoor air temperature and suction temperature is within 3 degrees			
	② Has the address of combination sub unit been set?	Set SW4-7 to ON			
	③ Have the foundation and foundation bolt been constructed? Is the discharge of drain water and rain water normal?	Check through technical materials. The structure shall be able to discharge drain water and rain water			
	④ Do the outdoor unit and indoor unit use different power sources?	In principle, different power sources shall be used respectively			
	⑤ Total required power capacity of combined Main units and sub units within allowable range (or different power sources used)?	Total value of required power source capacity is within allowable range (or different power sources are used)			
	⑥ Is the power voltage within the restricted range?	Inter-phase imbalance during operation: below $\pm 10\%$ Voltage drop when starting the compressor: within $-15\%$			
	⑦ Do the piping and circuit breaker use products conforming to specifications?	Check through technical materials			
	⑧ Is every unit installed with leakage protector?	Leakage protector is set for each unit (except for central power of combination)			
	⑨ Is earth wire installed?	Execution of earth work			
	⑩ In case of combination, has the oil equalizing pipes for Main unit and sub unit been constructed?	Construction must be carried out			

Note If the criterion is reached, fill O in the "Results" column; if not reached, fill X and results (but for some items, it is necessary to fill in both O and numerical values).

Classification	Check item	Criterion	Result	Fill in the results or numerical values	Date of implementation
3. System	① Is the refrigerant piping material qualified?	JIS, seamless phosphor-deoxidized copper pipe			
	② Is the length of refrigerant piping within restricted range?	Check through technical materials		<b>Piping length:</b>	
	③ Is the height difference between outdoor unit and indoor unit within limit value?	Check through technical materials (within 15m among indoor units)		<b>Height difference:</b>	
	④ Are the size and wall thickness of refrigerant piping determined according to indoor unit capacity?	Check through technical materials (size and wall thickness shall be determined according to indoor unit capacity)			
	⑤ Is there any trap or housing piping along the refrigerant piping?	Trap and housing piping shall not be set			
	⑥ During pipe welding, (a) is nitrogen gas used? (b) is the operating valve cooled?	(a) Implement while discharging nitrogen gas or after displacement (to control oxidization scale)			
	⑦ During construction, is the piping port sealed or have measures been taken to prevent rain water and dust from entering?	Seal so that it is difficult to remove. Measures to prevent foreign matters from entering temporarily set piping			
	⑧ Are qualified branch pipes used?	Check the No. of qualified parts through technical materials			
	⑨ Are branch pipes correctly set?	Check through technical materials (horizontally or vertically set)			
	⑩ Is the refrigerant piping supported by suspension bolt (shockproof)?	Support at the interval of 2m			
	⑪ Is the refrigerant piping (liquid pipe, gas pipe) heat insulated?	Materials with heat resistance of above 120°C Materials not causing dew on piping surface at 0~5°C			
	⑫ Is the refrigerant piping shockproof treated and heat insulated for the section crossing the wall and beam?	Implement shockproof and heat insulation construction			
	⑬ Is the air-tightness test conducted? (nitrogen gas used, excessive pressure prohibited)	Pressure: KX: 4.5MPa (no pressure variation within 24 hours)		<b>Pressure value after 24 hours:</b> MPa	
	⑭ Is the vacuuming work done sufficiently? (vacuuming from liquid pipe, gas pipe)	When vacuum degree reaches 755mmHg, vacuum at least 60 minutes.		<b>Vacuuming time:</b> min	
	⑮ Is the refrigerant amount calculated for the part of field piping?	Refer to technical materials (additional charge amount is for liquid pipe)		<b>Additional charge amount:</b> kg	
	⑯ Is the specified refrigerant charged as per amount?	Measure with scale (when stopping, charge liquid refrigerant through operation.)			
	⑰ Is the nameplate of outdoor unit marked with calculated value and charged amount of refrigerant, etc?	Fill in the piping size, piping length and refrigerant charge amount			

4. Communication system	① Are the signal wire and power cord mixed?	Signal wire terminal block resistance (appropriate value: $9100 / \text{number of connected units}$ , there are mixed wires under $100\Omega$ )			
	② Are the internal & external signal wires and remote controller wires mixed?	Wiring mistake has been resolved			
	③ Is there any circular wiring in the internal and external signal wires?	Circular wiring has to be corrected			
	④ Are the type and size of signal wires correct? (one side shall be earthed when using shielded wires)	Size: $0.75 \sim 2.0\text{mm}^2$ Wire type: VCTF, VCT, CVV, MVVS			
	⑤ Are address numbers assigned properly?	Consideration must be given to combination of indoor unit and outdoor unit, usage of room, period of usage, type of tenant, etc.			
	⑥ Are address numbers of indoor and outdoor units clearly indicated on the equipment drawings (indoor unit configuration drawing, etc)?	Fill in the equipment drawing			
	⑦ Are drawings submitted to address setting workers and instructions for address setting given?	Indication is done by drawing (signal wire, individual: automatic, manual; signal wire, super-link: manual)			
Test run	① Is the power turned on six hours before test run?	Crank case heater must be switched on 6 hours before test run		<b>Energizing time:</b> <b>H</b>	
	② Is every operating valve opened?	Open suction pipe, discharge pipe and operating valve of oil equalizing pipe			
	③ Is the wiring connection loosened?	Wiring connection is not loose			
	④ Is the combination of indoor and outdoor units (address or refrigerant piping) wrong?	Confirm correct combination through heat exchanger temperature, etc.			
	⑤ Is the system confirmed flawless through operating data?	Refer to test run instruction manual			
	⑥ Is the drain discharge test conducted?	Confirm water leakage, clogging, etc.			

Note If the criterion is reached, fill O in the Results column; if not reached, fill X and results (but for some items, fill in both O and numerical values).

If any other problem is found, also fill in.



## 2. Troubleshooting

### 2.1 Before Starting Troubleshooting

#### 2.1.1 Confirmation of the error code on the remote controller (by pressing the inspection switch) and the inspection display and normal display lamps on PCBs (Printed circuit board) of indoor / outdoor units

The microcomputer detects errors on electrical components, which include the microcomputer itself, errors on the power supply line and errors (overload, etc.) on the refrigerant circuit and the location of trouble is displayed (with the combination of error symbols of remote controller, normal (green) and inspection (red) display LED on PCBs of indoor / outdoor units). When any error occurs, check first the inspection display. It will guide you to trouble point and assist you to complete the repair work quickly.

Error code of the remote controller is recorded on microcomputer after the trouble has been reset automatically so that, if you press the inspection switch of remote controller, the error code and the number of unit in trouble are displayed for 10sec.. The inspection display lamp on the indoor / outdoor unit PCB keeps flashing (glowing) even after the trouble was reset automatically. Inspection lamp on the indoor unit PCB is turned off if the remote controller is reset.

a) Inspection / normal: List of power display

Section	Display Section	Display	Contents of display
Remote controller	Power supply display	LCD	At power ON : Displays always the return air temperature and Center/Remote.
	Error code	LCD	At error : Displays E1 ~ E63 or blank depending on the kinds of error.
	Inspection display	Red-LED	At error : Flash continuously (indicates the occurrence of error).
Indoor / outdoor unit	Normal display	Green-LED2	At power ON (normal) : Flash continuously. At error : Off or continuous glowing or irregular illumination.
	Error display	Red-LED1	At error : Flash 1 ~ 3 times / 5 sec for indoor unit depending on the kinds of error, continuous flash, irregular illumination or off. At error : Flash 1 ~ 6 times / 10 sec for outdoor unit depending on the kinds of error, continuous flash, irregular illumination or off.
Inverter	Normal display	Green-LED	At power ON (normal) : Flash continuously. At error : Off or continuous glowing or irregular illumination.
	Error display	Red-LED	At error : Displays 1~4 flash lights up 1 time flashes: Current cut (power transistor over-current) • Short-circuited compressor wiring • Trouble on inverter PCB • Trouble on power transistor • Compressor motor neutral line disconnected. 2 time flashes: Power transistor overheat • Fastening of the power transistor to the heat dissipation fins (tighten the screws, apply silicone) is insufficient. • Power transistor is defective. 3 time flashes: Compressor rotor lock • Compressor breakdown • Inverter board breakdown 4 time flashes: Compressor starting is defective. • Compressor breakdown • Inverter board breakdown • Power transistor breakdown Lights up : Transmission error between inverter and outdoor unit • Connectors CN11 or CN12 or CN13 is disconnected or open wiring between connectors • Error on outdoor control PCB • Error on inverter PCB

b) Check Indicator Table

Whether a failure exists or not on the indoor unit and outdoor unit can be know by the contents of remote controller error code, indoor / outdoor unit green LED (power pilot lamp and microcomputer normality pilot lamp) or red LED (check pilot lamp).

Remote controller error code	Indoor unit LED		Outdoor unit LED		Cause	
	Green	Red	Green	Red		
No-indication	Keeps flashing	Stays OFF	Keeps flashing	Stays OFF	Normal	
	Stays OFF	Stays OFF	Stays OFF	Stays OFF	Power OFF, T phase wiring is open, power source failure	
	Keeps flashing	*3 time flash	Keeps flashing	Stays OFF	Remote controller wires X and Y are reversely connected. *For wire breaking at power ON, the LED is OFF. Remote controller wire is open. (X wire breaking : A beep is produced and no indication is made. Z wire breaking : No beep and no indication) The remote controller wires Y and Z are reversely connected.	
E1	Keeps flashing	Stays OFF	Keeps flashing	Stays OFF	The remote controller wires are connected to A and B on the terminal block. The indoor/outdoor signal wire are connected in loop form. The indoor unit micro computer runs away.	
	Stay OFF or Lights continuously	Stay OFF or Lights continuously	Keeps flashing	Stays OFF	Indoor unit PCB fault	
	Keeps flashing	*3 time flash	Keeps flashing	Stays OFF	Remote control wire breakage (signal) *For wire breaking at power ON, the LED is OFF.	
E2	Keeps flashing	1 time flash	Keeps flashing	Stays OFF	No. duplication at indoor unit addressing. More than 49 indoor unit are connected.	
E3	Keeps flashing	2 time flash	Stays OFF	Stays OFF	Outdoor unit power supply OFF (detected only during operation)	
	Keeps flashing	2 time flash	Keeps flashing	Stays OFF	The corresponding outdoor unit address No. is not found. (Detected only during operation)	
	Keeps flashing	2 time flash	Irregular illumination	Stays OFF or Lights continuously	Outdoor unit power OFF (Detected only during operation)	
E5	Keeps flashing	2 time flash	Keeps flashing	Stays OFF	Indoor / outdoor transmission error. Wire A and B swapping after power ON.	
	Keeps flashing	2 time flash	Stays OFF	Stays OFF	Outdoor power unit failure (when the indoor power supply is different from the outdoor one).	
	Keeps flashing	2 time flash	Irregular illumination	Stays OFF or Lights continuously	Outdoor unit microcomputer failure	
E6	Keeps flashing	1 time flash	Keeps flashing	Stays OFF	Indoor unit heat exchanger thermistor failure	
E7	Keeps flashing	1 time flash	Keeps flashing	Stays OFF	Indoor unit return air thermistor failure	
E9	Keeps flashing	1 time flash	Keeps flashing	Stays OFF	The float SW operates (with FS only). Drain up kit wiring fault.	
E10	Keeps flashing	Stays OFF	Keeps flashing	Stays OFF	When multi-unit control by remote controller is performed, the number of units is over (more than 17 units). Two remote controller are provided for one controller is performed.	
E11	Keeps flashing	Stays OFF	Keeps flashing	Stays OFF	Addresses setting for plural remote controllers	
E12	Keeps flashing	1 time flash	Keeps flashing	Stays OFF	Addresses No. combination error or addressing is performed with the following combinations.	
					Outdoor No,	Indoor No,
					0~47	48, 49
					48, 49	0~47
E16 <sup>(1)</sup>	Keeps flashing	1 time flash	Keeps flashing	Stays OFF	Defect of fan motor.	
E28	Keeps flashing	Stays OFF	Keeps flashing	Stays OFF	Remote controller thermistor failure	

Note (1) In the case of FDT112, 140 or FDK22~56 type.

**FDCA140HKXEN4**

Remote controller error code	Indoor unit LED		Outdoor unit LED		Outdoor LED 7-Segment	Cause
	Green	Red	Green	Red		
E30	Keeps flashing	Stays OFF	Keeps flashing	1 time flash	E30	Unmatched indoor / outdoor connection
E31	Keeps flashing	Stays OFF	Keeps flashing	1 time flash	E31	Duplication outdoor unit address No. Outdoor unit address setting error.
E32	Keeps flashing	Stays OFF	Keeps flashing	1 time flash	E32	L3-phase wiring is open phase or reversal phase
E35	Keeps flashing	Stays OFF	Keeps flashing	1 time flash	E35	The high-pressure abnormality for cooling
E36	Keeps flashing	Stays OFF	Keeps flashing	1 time flash	E36	Discharge temperature (Tho-D) anomaly.
E37	Keeps flashing	Stays OFF	Keeps flashing	1 time flash	E37	Outdoor unit heat exchanger thermistor (Tho-R) failure
E38	Keeps flashing	Stays OFF	Keeps flashing	1 time flash	E38	Outdoor air temperature thermistor (Tho-A) failure
E39	Keeps flashing	Stays OFF	Keeps flashing	1 time flash	E39	Discharge temperature thermistor (Tho-D) failure
E40	Keeps flashing	Stays OFF	Keeps flashing	1 time flash	E40	High pressure error
E41	Keeps flashing	Stays OFF	Keeps flashing	1 time flash	E41	Power transistor overheat
E42	Keeps flashing	Stays OFF	Keeps flashing	1 time flash	E42	Anomalous current cut of compressor
E43	Keeps flashing	Stays OFF	Keeps flashing	1 time flash	E43	The number of connectable units is exceeded.
E45	Keeps flashing	Stays OFF	Keeps flashing	1 time flash	E45	Transmission error between inverter and outdoor unit control PCB
E46	Keeps flashing	Stays OFF	Keeps flashing	Stays OFF	E46	Automatic address setting and remote controller address setting coexists in the same network.
E49	Keeps flashing	Stays OFF	Keeps flashing	1 time flash	E49	Low pressure error (PSL)
E53	Keeps flashing	Stays OFF	Keeps flashing	1 time flash	E53	Suction pipe temperature thermistor failure
E54	Keeps flashing	Stays OFF	Keeps flashing	1 time flash	E54	Low pressure sensor disconnection / output error
				2 time flash	E54	High pressure sensor disconnection / output error
E59	Keeps flashing	Stays OFF	Keeps flashing	1 time flash	E59	Compressor startup error
E60	Keeps flashing	Stays OFF	Keeps flashing	1 time flash	E60	Compressor rotor position detection error

## FDCA224, 280, 335HKXE4

Remote controller error code	Indoor unit LED		Outdoor unit LED		Outdoor LED 7-Segment	Cause
	Green	Red	Green	Red		
E30	Keeps flashing	Stays OFF	Keeps flashing	1 time flash	E30	Unmatched indoor / outdoor connection
E31	Keeps flashing	Stays OFF	Keeps flashing	1 time flash	E31	Duplication outdoor unit address No. Outdoor unit address setting error.
E32	Keeps flashing	Stays OFF	Keeps flashing	1 time flash	E32	L3-phase wiring is open phase or reversal phase
E36	Keeps flashing	Stays OFF	Keeps flashing	1 time flash	E36-1	Discharge temperature abnormality.
E37	Keeps flashing	Stays OFF	Keeps flashing	1 time flash	E37-1	Outdoor unit heat exchanger thermistor (Tho-R1) failure
				2 time flash	E37-2	Outdoor unit heat exchanger thermistor (Tho-R2) failure
				3 time flash	E37-3	Outdoor unit heat exchanger thermistor (Tho-R3) failure
				4 time flash	E37-4	Outdoor unit heat exchanger thermistor (Tho-R4) failure
				5 time flash	E37-5	Outdoor unit heat exchanger thermistor (Tho-SC) failure
				6 time flash	E37-6	Outdoor unit heat exchanger thermistor (Tho-H) failure
E38	Keeps flashing	Stays OFF	Keeps flashing	1 time flash	E38	Outdoor air temperature thermistor (Tho-A) failure
E39	Keeps flashing	Stays OFF	Keeps flashing	1 time flash	E39-1	Discharge temperature thermistor (Tho-D1) failure
E40	Keeps flashing	Stays OFF	Keeps flashing	1 time flash	E40	High pressure error
E41	Keeps flashing	Stays OFF	Keeps flashing	1 time flash	E41-1	Power transistor overheat
E42	Keeps flashing	Stays OFF	Keeps flashing	1 time flash	E42-1	Abnormal current cut of compressor
E43	Keeps flashing	Stays OFF	Keeps flashing	1 time flash	E43	The number of connectable units is exceeded.
E45	Keeps flashing	Stays OFF	Keeps flashing	1 time flash	E45-1	Transmission error between inverter and outdoor unit control PCB
E46	Keeps flashing	Stays OFF	Keeps flashing	Stays OFF	—	Automatic address setting and remote controller address setting coexists in the same network.
E48	Keeps flashing	Stays OFF	Keeps flashing	1 time flash	E48-1	Anomaly in an outdoor fan motor 1
				2 time flash	E48-2	Anomaly in an outdoor fan motor 2
E49	Keeps flashing	Stays OFF	Keeps flashing	1 time flash	E49	Low pressure error
E53	Keeps flashing	Stays OFF	Keeps flashing	1 time flash	E53	Suction pipe temperature thermistor (Tho-S) failure
E54	Keeps flashing	Stays OFF	Keeps flashing	1 time flash	E54-1	Low pressure sensor (PSL) disconnection / output error
	Keeps flashing	Stays OFF	Keeps flashing	2 time flash	E54-2	High pressure sensor (PSH) disconnection / output error
E59	Keeps flashing	Stays OFF	Keeps flashing	1 time flash	E59-1	Compressor startup error
E60	Keeps flashing	Stays OFF	Keeps flashing	1 time flash	E60-1	Compressor rotor position detection error
E63	Keeps flashing	Stays OFF	Keeps flashing	1 time flash	E63	Emergency stop of indoor unit

**FDCA335HKXE4-K, 400 ~ 1360HKXE4**

Remote controller error code	Indoor unit LED		Outdoor unit LED		Outdoor LED 7-Segment	Cause
	Green	Red	Green	Red		
E30	Keeps flashing	Stays OFF	Keeps flashing	1 time flash	E30	Unmatched indoor / outdoor connection
E31	Keeps flashing	Stays OFF	Keeps flashing	1 time flash	E31	Duplication outdoor unit address No. Outdoor unit address setting error.
E32	Keeps flashing	Stays OFF	Keeps flashing	1 time flash	E32	L3-phase wiring is open phase
E36	Keeps flashing	Stays OFF	Keeps flashing	1 time flash	E36-1	Discharge temperature (Tho-D1) abnormality.
				2 time flash	E36-2	Discharge temperature (Tho-D2) abnormality.
E37	Keeps flashing	Stays OFF	Keeps flashing	1 time flash	E37-1	Outdoor unit heat exchanger thermistor (Tho-R1) failure
				2 time flash	E37-2	Outdoor unit heat exchanger thermistor (Tho-R2) failure
				3 time flash	E37-3	Outdoor unit heat exchanger thermistor (Tho-R3) failure
				4 time flash	E37-4	Outdoor unit heat exchanger thermistor (Tho-R4) failure
				5 time flash	E37-5	Outdoor unit heat exchanger thermistor (Tho-SC) failure
				6 time flash	E37-6	Outdoor unit heat exchanger thermistor (Tho-H) failure
E38	Keeps flashing	Stays OFF	Keeps flashing	1 time flash	E38	Outdoor air temperature thermistor (Tho-A) failure
E39	Keeps flashing	Stays OFF	Keeps flashing	1 time flash	E39-1	Discharge temperature thermistor (Tho-D1) failure
				2 time flash	E39-2	Discharge temperature thermistor (Tho-D2) failure
E40	Keeps flashing	Stays OFF	Keeps flashing	1 time flash	E40	High pressure (63H1-1, 2) error
E41	Keeps flashing	Stays OFF	Keeps flashing	1 time flash	E41-1	Power transistor (CM1) overheat
				2 time flash	E41-2	Power transistor (CM2) overheat
E42	Keeps flashing	Stays OFF	Keeps flashing	1 time flash	E42-1	Abnormal current cut of compressor (CM1)
				2 time flash	E42-2	Abnormal current cut of compressor (CM2)
E43	Keeps flashing	Stays OFF	Keeps flashing	1 time flash	E43	The number of connectable units is exceeded.
E45	Keeps flashing	Stays OFF	Keeps flashing	1 time flash	E45-1	Transmission error between inverter and outdoor unit control PCB (CM1)
				2 time flash	E45-2	Transmission error between inverter and outdoor unit control PCB (CM2)
E46	Keeps flashing	Stays OFF	Keeps flashing	Stays OFF	—	Automatic address setting and remote controller address setting coexists in the same network.
E48	Keeps flashing	Stays OFF	Keeps flashing	1 time flash	E48-1	Anomaly in an outdoor fan motor FM01
				2 time flash	E48-2	Anomaly in an outdoor fan motor FM02
E49	Keeps flashing	Stays OFF	Keeps flashing	1 time flash	E49	Low pressure error (PSL)
E51	Keeps flashing	Stays OFF	Keeps flashing	1 time flash	E51-1	Power transistor overheating (CM1) (15 minute continuation)
				2 time flash	E51-2	Power transistor overheating (CM2) (15 minute continuation)

Remote controller error code	Indoor unit LED		Outdoor unit LED		Outdoor LED 7-Segment	Cause
	Green	Red	Green	Red		
E53	Keeps flashing	Stays OFF	Keeps flashing	1 time flash	E53	Suction pipe temperature thermistor (Tho-S) failure
E54	Keeps flashing	Stays OFF	Keeps flashing	1 time flash	E54-1	Low pressure sensor (PSL) disconnection / output error
				2 time flash	E54-2	High pressure sensor (PSH) disconnection / output error
E59	Keeps flashing	Stays OFF	Keeps flashing	1 time flash	E59-1	Compressor startup error (CM1)
				2 time flash	E59-2	Compressor startup error (CM2)
E60	Keeps flashing	Stays OFF	Keeps flashing	1 time flash	E60-1	Compressor rotor position detection error (CM1)
				2 time flash	E60-2	Compressor rotor position detection error (CM2)
E61	Keeps flashing	Stays OFF	Keeps flashing	1 time flash	E61	Communication error between outdoor unit Main unit and sub units.
E63	Keeps flashing	Stays OFF	Keeps flashing	1 time flash	E63	Emergency stop of indoor unit

- c) Display sequence of error, inspection display lamp
- 1) One kind error  
Display corresponding to the error is shown.
  - 2) More than one errors.

Section	Display section
Error code of remote controller	<ul style="list-style-type: none"> <li>• Displays the error of higher priority (When plural errors are persisting) <i>E1 &gt; E10 &gt; E11 &gt; E2 &gt; E3 &gt; E5 &gt; E7 &gt; E9 &gt; E12 . . . . . E63</i></li> <li>• Displays the present errors. (When a new error has occurred after the former error was reset.)</li> </ul>
Inspection LED (red) of indoor unit PCB	
Inspection LED (red) of indoor unit PCB	

- 3) Timing of error detection
  - Indoor unit side.

Error detail	Error code	Timing of error detection
Transmission error of remote controller indoor unit	<i>E1</i>	When the transmission error continuously for 2 min.
CPU is out of control		Resetting was performed at the rate of 1 time per second. An abnormal stop occurred 32-sec time flash.
Transmission error between indoor/outdoor units	<i>E5</i>	A check was made once every 20 second. An abnormal stop occurred 7 time running.
Open wire of heat exchanger thermistor	<i>E6</i>	After a compressor ON command, this failure was detected for 5 second in the period of 2 minutes to 2 minutes and 20 seconds.
Open wire of indoor unit return air thermistor	<i>E7</i>	This failure was detected continuously for 5 seconds.
Drain error (float switch motion)	<i>E9</i>	At all times from 31 seconds after power ON.

- Outdoor unit side.

Error detail	Error code	Timing of error detection	
Open phase of power supply	<i>E34</i>	Power supply is always at ON	
Discharge temperature anomaly	<i>E36</i>	A stop occurs when this anomaly occurs for 2 seconds running at 130°C. After a stop for 3 minutes, a recovery is automatically made. An anomalous stop occurs when this anomaly occurs 2 times for 60 minutes. (The abnormal state is held for 45 minutes.)	
Open wire of heat exchanger thermister		<i>E37</i>	This failure is detected when it occurs for 5 seconds running in the period of 2 minutes to 2 minutes and 20 seconds with the compressor ON. An anomalous stop occurs when this failure occurs 3 times for 40 minutes.
Defective outdoor unit heat exchange and sub-cooling coil thermister			
Open wire of outdoor temperature thermistor	<i>E38</i>		
Open wire of discharge thermistor	<i>E39</i>	This failure is detected when it occurs for 5 seconds running in the period of 10 minutes to 10 minutes and 20 seconds with the compressor ON. An anomalous stop occurs when this failure occurs 3 times for 40 minutes.	
High pressure cut	<i>E40</i>	An anomalous stop occurs when this anomaly occurs 5 times for 60 minutes.	
Low-pressure pressure is anomalous	<i>E49</i>	Continuous detection is done for 30 (10) <sup>(1)</sup> second while the compressor is stopping and the anomalous stops happen 5 (3) <sup>(1)</sup> times in 60 minutes.	
Defective suction pipe temprature thermistor	<i>E53</i>	This failure is detected when it occurs for 5 seconds running in the period of 2 minutes to 2 minutes and 20 seconds with the compressor ON. An anomalous stop occurs when this failure occurs 3 times for 40 minutes.	
Open wire of low pressures sensor			
Open wire of high pressures sensor			

Error detail	Error code	Timing of error detection
Excessive number of indoor unit	E43	This error is detected when the number of connectable units is set over the specified value at remote control addressing.
Transmission error between inverter and outdoor unit PCB	E45	With a delay of 3 minutes, a recovery is automatically made. An abnormal stop occurs when this errors occurs 4 times for 15 minutes.

Note (1) The numerical value inside ( ) displays for 140 type.

4) Recording and reset of error

Error display	Memory	Reset
Error code	<ul style="list-style-type: none"> <li>Saves in memory the mode<sup>(1)</sup> of higher priority</li> </ul>	<ul style="list-style-type: none"> <li>Stop the unit operation by pressing the ON / OFF switch of remote controller.</li> <li>Operation can be started again if the error has been reset.<sup>(2)</sup></li> </ul>
Indoor unit inspection lamp (red)	<ul style="list-style-type: none"> <li>Cannot save in memory</li> </ul>	
Outdoor unit inspection lamp (red)	<ul style="list-style-type: none"> <li>Saves in memory the mode<sup>(1)</sup> of higher priority</li> </ul>	

Notes (1) Priority is in the order of E1 > ... > E10 > ... > 63.

(2) Reset is disabled for 45min. at the error of outdoor unit or compressor overcurrent or the discharge gas temperature error.

5) Reset of error code in memory (when the error has been reset.)

After the unit breaks down and the error code is displayed, if pushing "ON / OFF switch" the unit is turned OFF, then "ON / OFF switch" is pushed again, the unit is turned ON. At this time the breakdown has returned automatically if the unit starts. However, the error code remains being memorized. The way of releasing error code in memory for this case is shown.

Indoor unit : Push "ON / OFF Switch" of remote controller, or detach the power supply connector (CNW2) of indoor unit PCB and then connect again, or turn OFF the power.

Outdoor unit: Detach the power supply connector (CNA2) of outdoor unit PCB and then connect again or turn OFF the power supply or turn on and off the SW3-1.

### 2.1.2 Procedures of trouble diagnosis

When any error occurs, inspect in following sequence. Detailed explanation on each step is given later in this text.

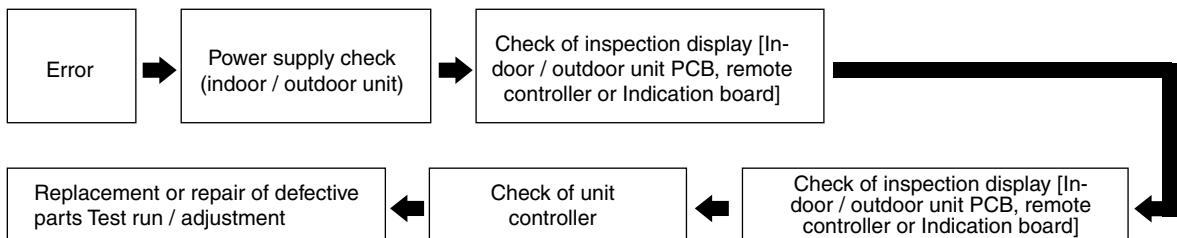

Note (1) In order to return the malfunction of the microcomputer due to the influence of a power supply status and a transitory noise, the power supply is turned off once, then after above 1 minute, it turns on again. The above mentioned is called as checking operation.



### 2.1.3 Diagnosis by the power supply reset

When any error occurs, reset the power supply as described below to see if it is the result of accidental noise, etc.

Check at the indoor unit side.

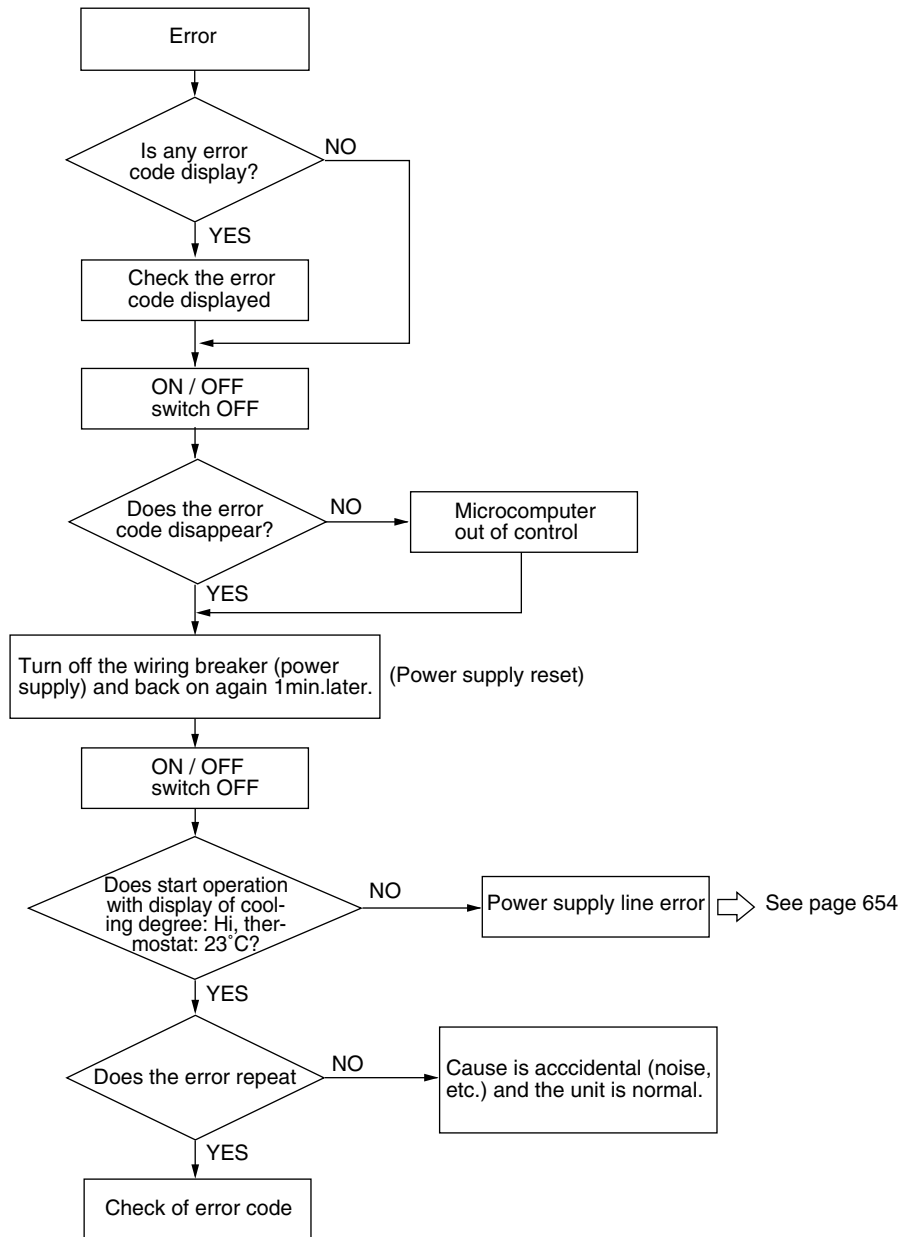

**Errors due to external noise, etc.**

Error code may be displayed or the error may not be displayed normally even if the controller is normal because of external noise source(1) or joined or parallel arrangement of power cables and signal wires. It is because the wire of remote controller, wired remote controller signal wires for multiple units or the network signal wires may be influenced by external noises which are judged as signals by the microcomputer which reacts mistakenly. When there is any noise source, it is necessary to shield wire for the remote controller and signal wires.

Note (1) High frequency medical machine, rectifier motor application device, thyristor, broadcast transmission tower, power transmission line, power line of electric train, automatic door motor, elevator (voltage drop), wireless telephone, high voltage power distribution line, computer, personal computer and their cables.

These do not necessarily always cause problems but they can be a source of electrical noise.

(2) **Reference** Effect of noise

■ When noises intrude into remote controller.

Abnormal or irregular display such as the flashing of irrelevant display (lamp) (for example, LEDs of cooling and heating illuminated simultaneously or the like) is observed even if the remote controller is not operated or the remote or the remote controller and, as the result, the operation of units may be disabled or similar abnormal phenomena are observed.

- When noises intruded into the microcomputer of printed circuit board; State of operation becomes abnormal such as the units perform irregular operation while the remote controller is not operated, the operation cannot be stopped with the remote controller, etc.

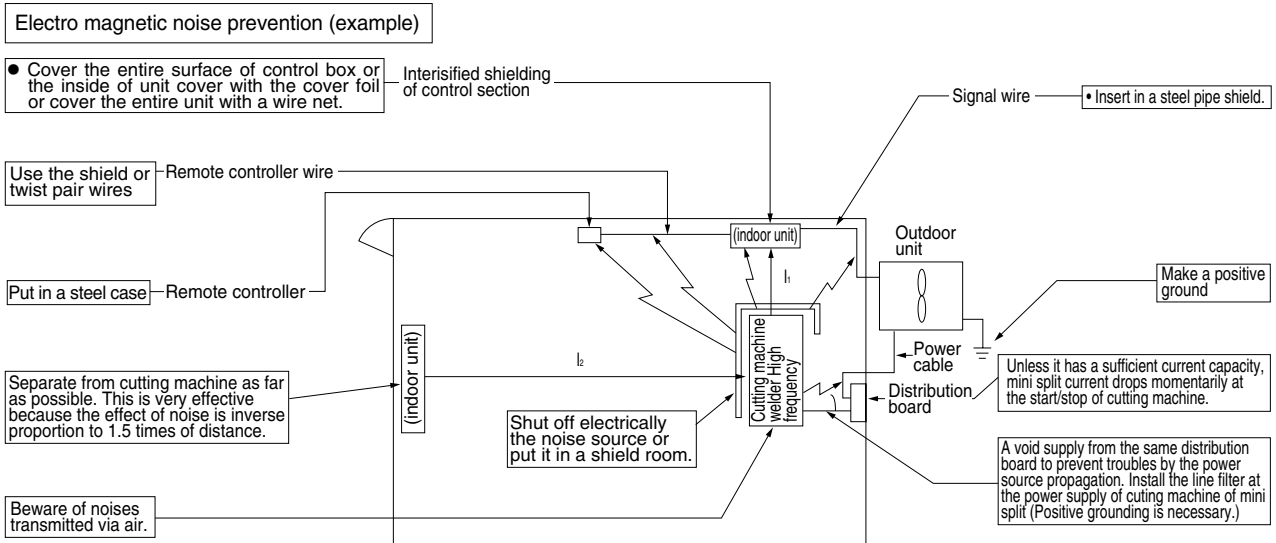

## 2.2 Operation Flowcharts

### 2.2.1 Indoor unit operation flowchart

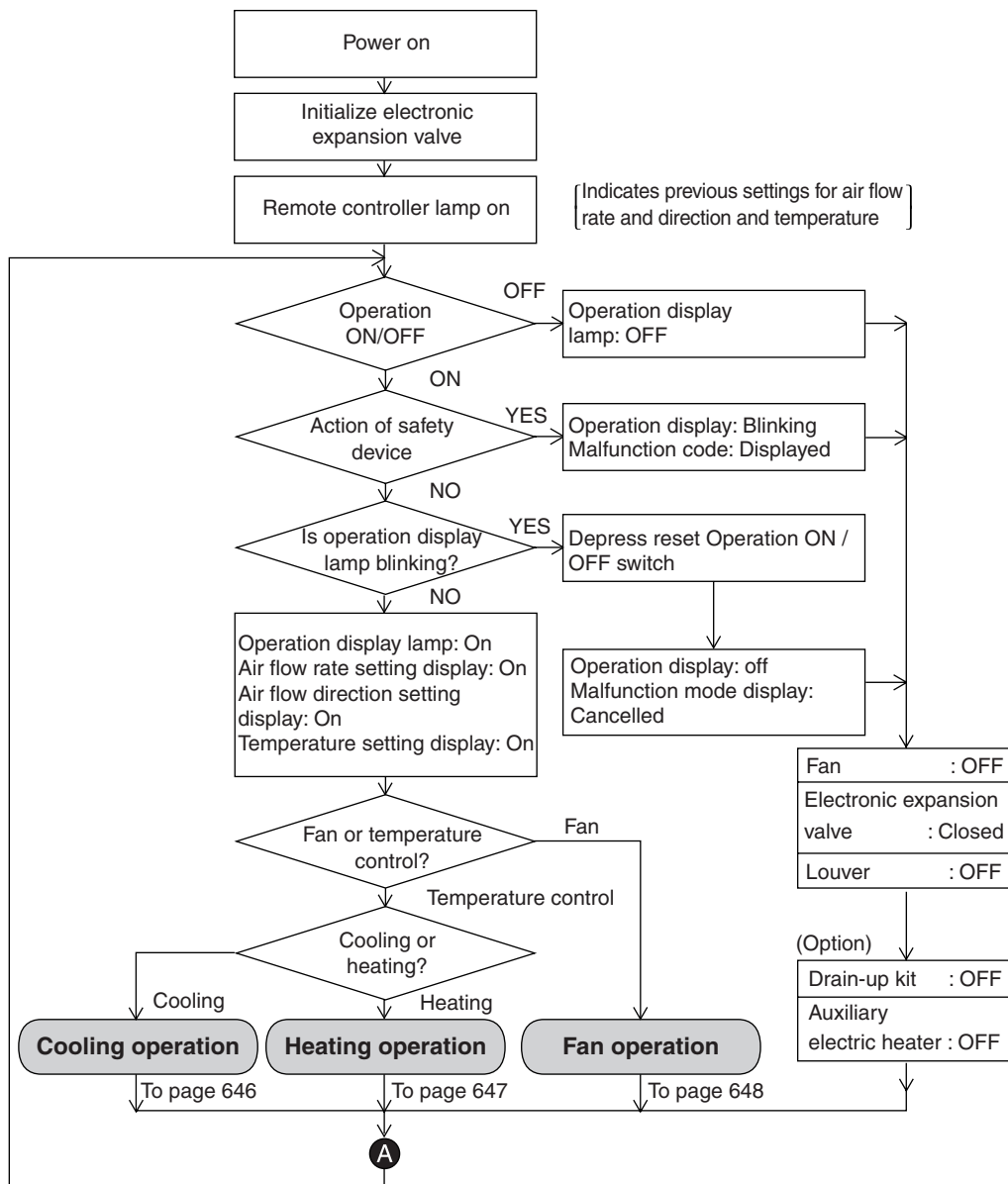

Cooling operation

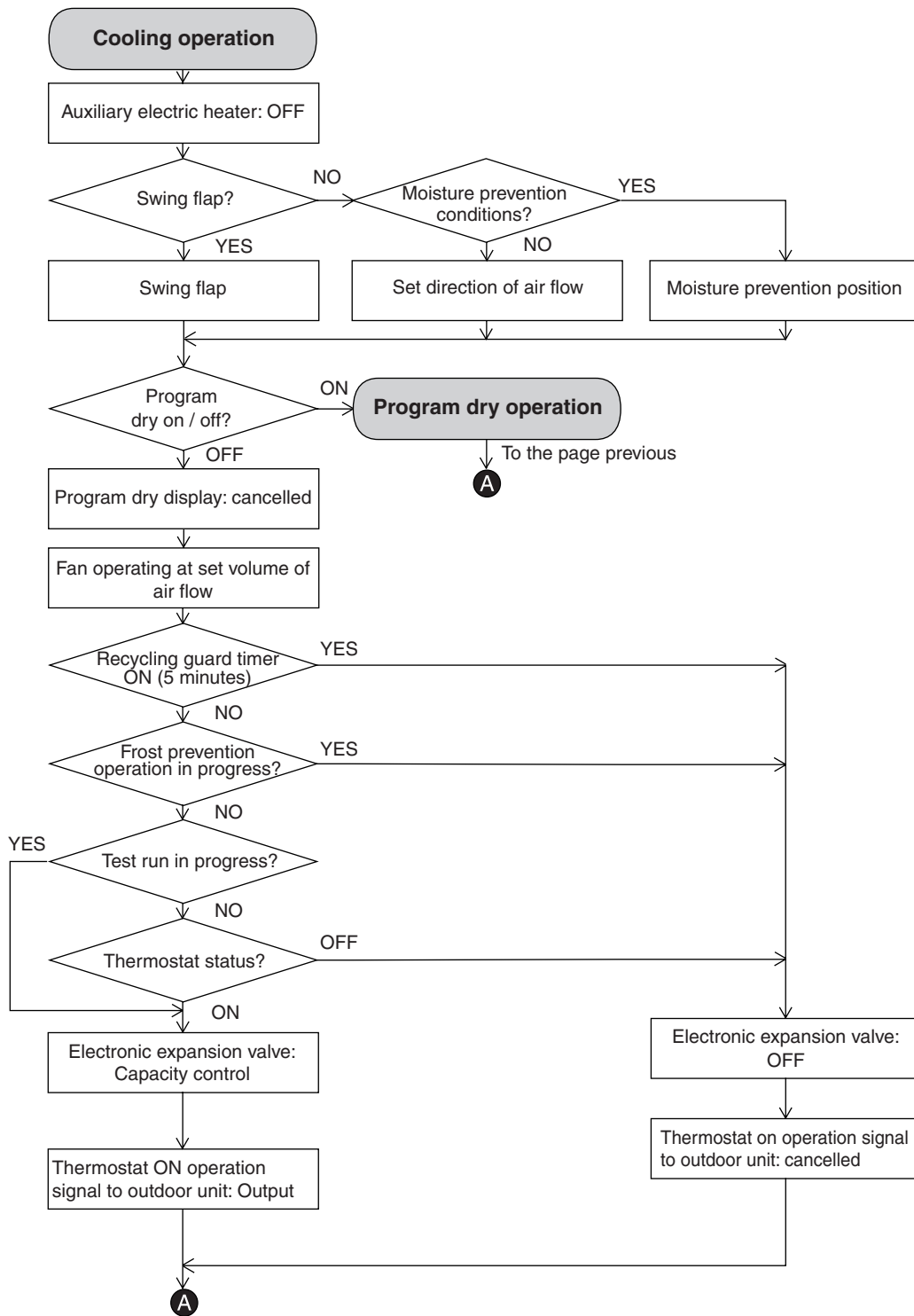

Heating operation

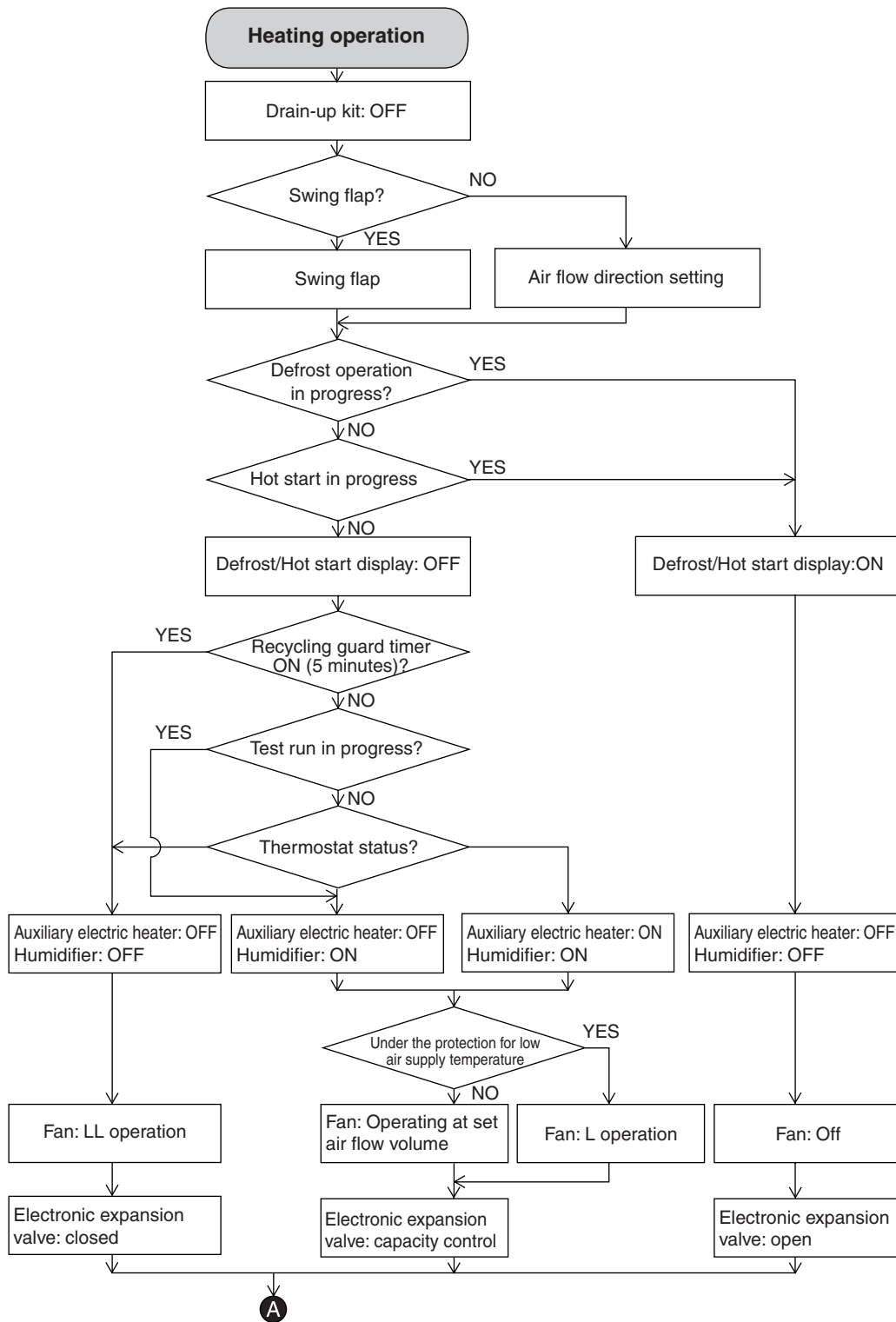

Fan operation

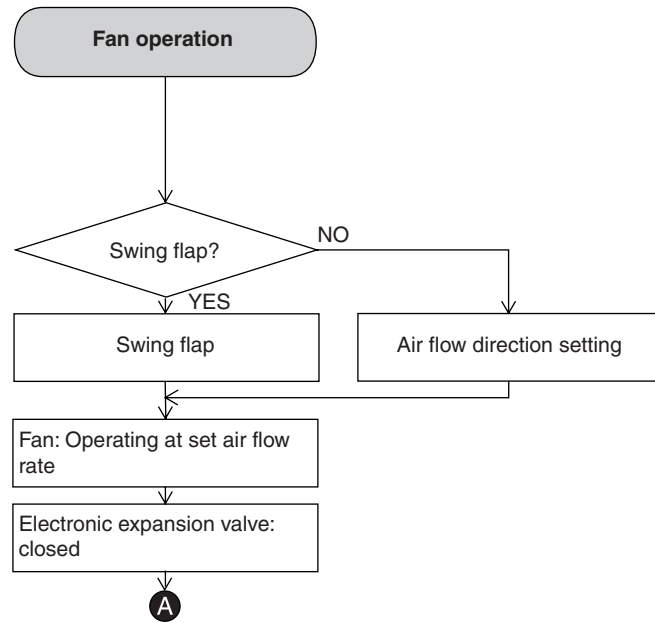

Program dry operation

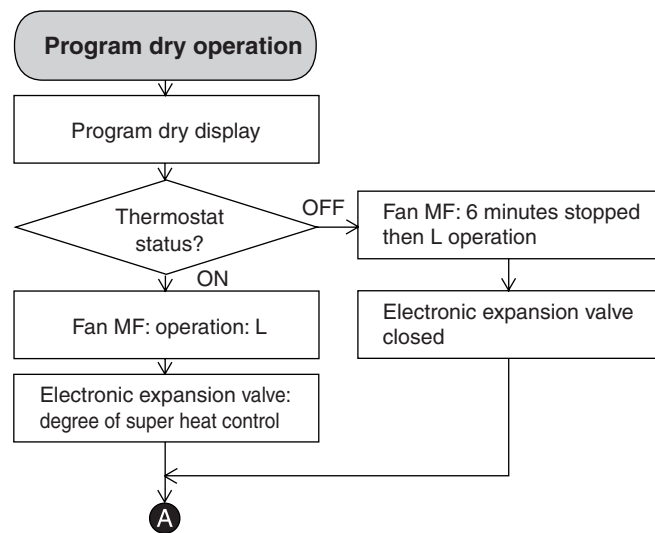

### 2.2.2 Outdoor unit operation flowchart

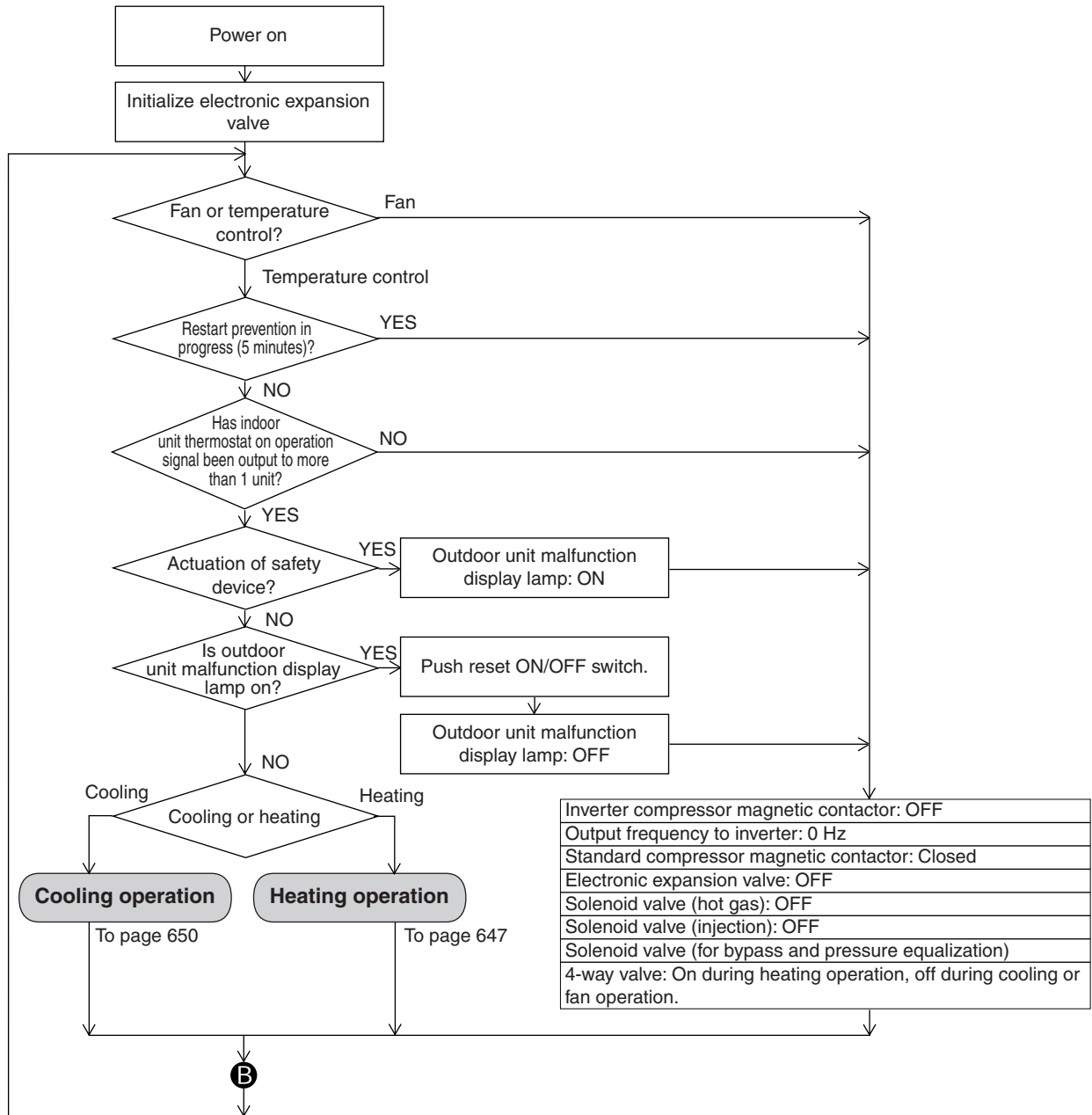

Cooling operation

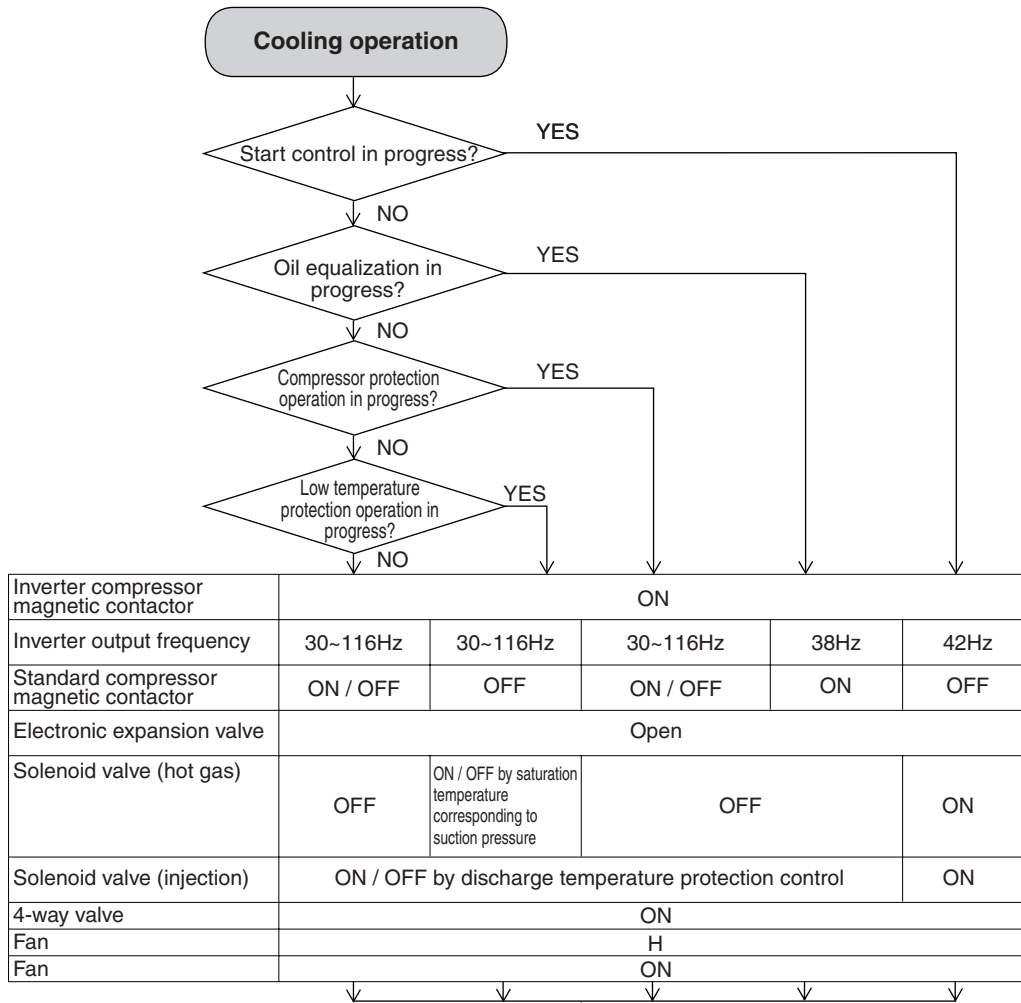

**B**

### 2.3 Error Diagnosis Procedures at the Indoor Unit Side

To diagnose the error, measure the voltage (AC,DC), resistance, etc. at each connector around the printed circuit board of indoor unit PCB on the inspection display or the operation state of unit (no operation of compressor or blower, no switching of 4-way valve, etc.). If any defective parts are discovered, replace with the assembly of parts as shown below.

- (1) Unit of replacement parts related to indoor unit printed circuit board ( Electric components on and around the microcomputer)

Indoor unit printed circuit board, thermistor (Return air, heat exchanger), remote controller switch, limit switch, transformer, fuse

Note (1) Judges the troubles on the parts of driving power circuit or cooling cycle with the ordinary check method.

- (2) Points for printed control board (PCB) exchange.

- a) Refer to the table of spare parts drawing No. for control PCB  
PCB = printed circuit board.

MODEL	Spare parts drawing No.
FDTA28 ~ 90	PJA505A127ZD
FDTA112 ~ 140	PJA505A127ZC
FDTSA	PJA505A132ZB
FDTWA, FDRA, FDU A, FDUMA, FDFLA, FDFUA	PJA505A132ZA
FDEA	PJA505A129ZG
?	PHA505A0208A
?	PJA505A132ZB
?	PJA505A047BP

- b) Set the Dip Switch to the same position before PCB is replaced.  
Set the Dip Switch to the ON if with jumper wire or to the OFF if without jumper wire.
  - c) Connect the Fast on terminal and the connector to the PCB. Match the wiring color of the fast on terminal to the color printed on the PCB and connect them together with.
- Note(1) Please connect the PCB carefully so as not to deform the board (PCB) extremely when connecting it with the Fast on terminal.

(3) Power PCB

Make sure the part number and the applicable model.

Part number	Applicable model
PJA505A110ZG	FDTA28, 36, 45, 56, 71, 901
PJA505A110ZF	FDTA112, 1401

Parts layout on the indoor unit printed circuit board  
The control board in the following figure shows for the FDT type.

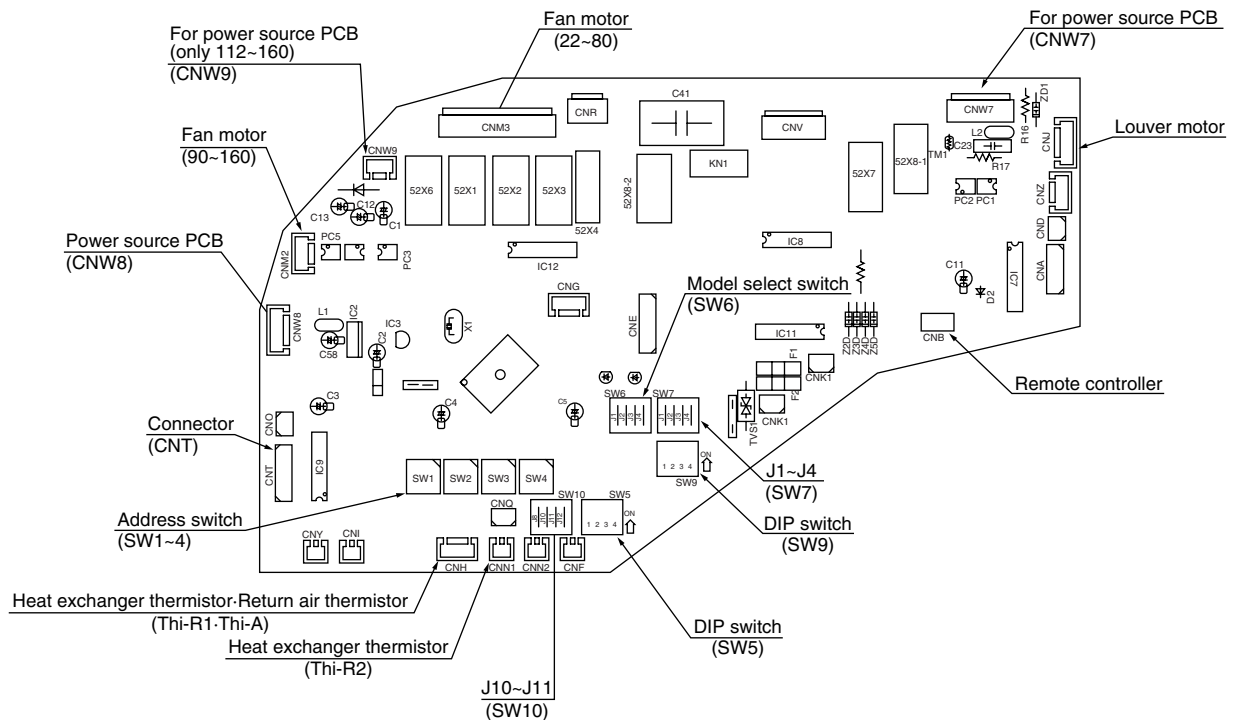

Function of jumper wires

Name			Function
J1 (SW7-1)	With		Filter sign: Valid
	None <sup>(1)</sup>		Filter sign: Invalid
J2 (SW7-2)	With		Normal operation operable
	None <sup>(1)</sup>		Operation permission prohibited
J3 (SW7-3)	With	J4(SW7-4)	Heating thermostat OFF: Lo operation
			Heating thermostat OFF: Intermittent operation
	None <sup>(1)</sup>	—	Heating thermostat OFF: Stop
			Heating thermostat OFF: —
J8 (SW8-4)	With		Humidifier drain operating : ineffective
	None <sup>(1)</sup>		Humidifier drain operating : effective
J10 (SW10-2)	With	J11(SW10-3)	Remote controller air flow: 3 speed
			Remote controller air flow: 1 speed
	None <sup>(1)</sup>		Remote controller air flow: 2 speed
			Remote controller air flow: —

Notes (1) "None" means that jumper wire is not provided on the PCB or the connection is cut  
(2) Supare parts PCB is equipped with no jumper J1~J11. Instead, SW7, 8, and 10 with the same function as J1~J11 are mounted on the position of the jumper and set SW7, 8, and 10 in the locale according to the above table, please.



**Function of DIP switches (SW5, 9)**

Switch		Function
SW5-1	ON	Test run of condensate pump motor
	OFF	Normal
SW5-2	ON	Humidifier residual operating: effective
	OFF	Humidifier residual operating: ineffective
SW5-3	ON	Input: Reverse Invalid
	OFF	signal: Run stop
SW5-4	ON	Emergency stop signal: Invalid
	OFF	Emergency stop signal: Valid

Note (1) All OFF when shipping it.

**Function of DIP switches (SW9)**

Switch			Function	
SW9-1	OFF	SW9-2	ON	The autolift control length: 1.3m
			OFF	The autolift control length: 1.6m
	ON	SW9-2	ON	The autolift control length: 2.0m
			OFF	The autolift control length: 4.0m
SW9-3			ON	Louver stop: Airstream attainment
			OFF	Louver stop: Ceiling dirt prevention
SW9-4			ON	Fan control: UH, H, M
			OFF	Fan control: H, M, L

Note (1) All OFF under load condition.

**Model select switch (SW6)**

Switch \ Model	22	28	36	45	56	71	80	90	112	140	160	224	280
SW6-1	OFF	ON	OFF	ON	OFF	ON	OFF	ON	OFF	ON	OFF	ON	OFF
SW6-2	OFF	OFF	ON	ON	OFF	OFF	ON	ON	OFF	OFF	ON	ON	OFF
SW6-3	OFF	OFF	OFF	OFF	ON	ON	ON	ON	OFF	OFF	OFF	OFF	ON
SW6-4	OFF	OFF	OFF	OFF	OFF	OFF	OFF	OFF	ON	ON	ON	ON	ON

Note (1) All OFF under load condition.

(4) Check method when the error code is displayed

Remote controller or Indication board: Inspection LED, error code

Indoor unit PCB: Red LED ( inspection display), Green LED ( CPU. normal display )

Outdoor unit PCB: Red LED ( inspcetion display), Green LED ( CPU. normal display )

(5) Check procedure depending on indication lamps (For the indoor unit)

The next page error diagnosis is applicable to cases where only 1 unit is installed in a network unless stated otherwise but the check method is same even if there are multiple units on the network. Except the network occupation state due to out of control indoor unit CPU, the error display indicates the state of respective units.

Check each unit specified by the error display as explained on next page.

<b>1</b>	Error display : No display LCD display : No display	[Polarity determination trouble]
----------	--	----------------------------------

Indoor unit		Outdoor unit	
Red LED	Stays OFF	Red LED	Stays OFF
Green LED	Keeps flashing	Green LED	Keeps flashing

- When the LCD display (Center / Remote, temperature display, etc.) of remote controller flashes, it means the polarity on the unit is not yet determined. Polarity determination is completed within a few seconds after the power on. If it is not completed in time, CPU out of control, etc. is suspected.

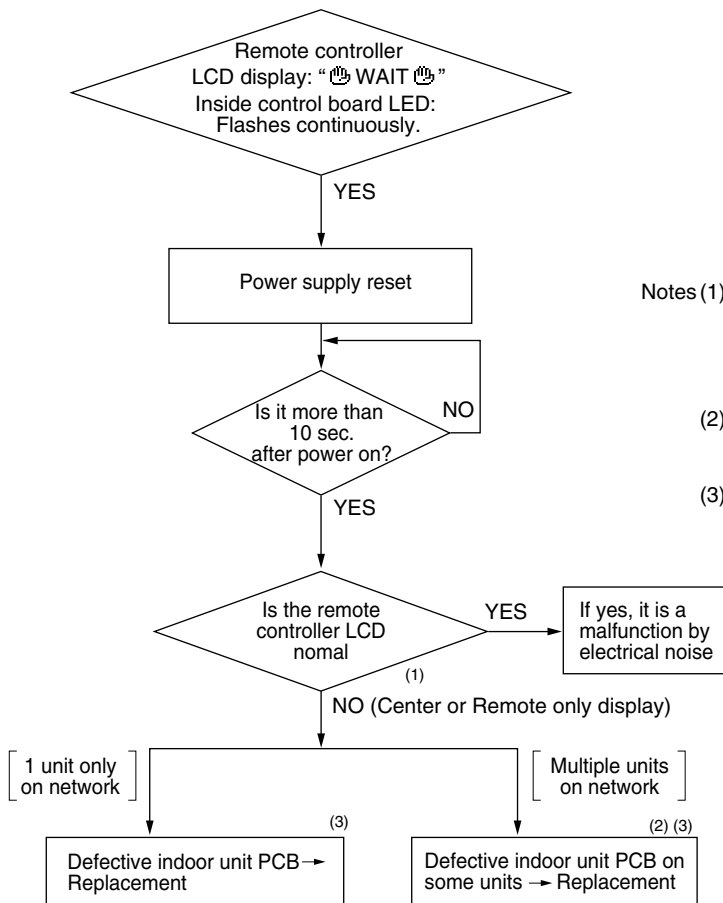

- Notes (1) When CPU of one unit goes out of control, it occupies the transmission section of the network, so the transmission of other units are not done and the polarity of the whole network will not be determined.
- (2) The unit which has its indoor and green LED keeps flashing (or no lighting) is the one with a defective indoor unit PCB.
- (3) If it becomes normal after replacing the PCB, it can be considered that the PCB is defective (defective network transmission circuit).

2

Error display : No display  
LCD display : No display

[Power supply line error]

Outdoor unit

Red LED	Stays OFF
Green LED	Stays OFF

Indoor unit

Red LED	Stays OFF
Green LED	Stays OFF

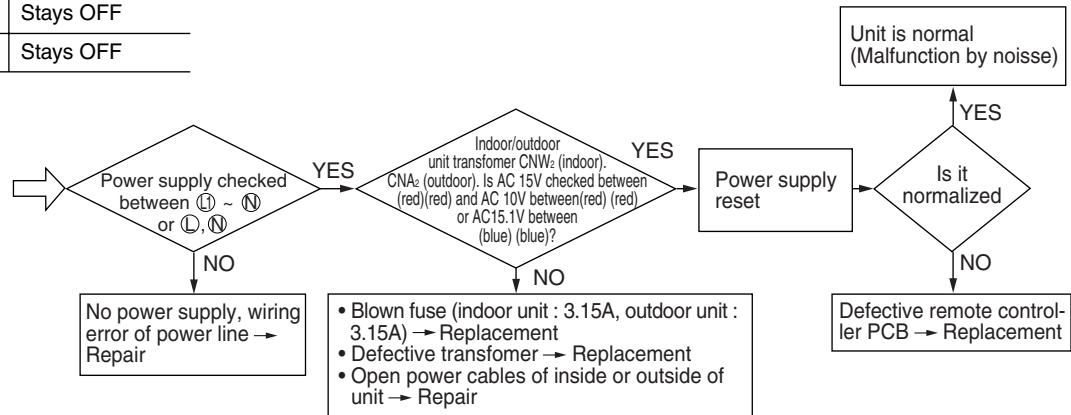

Indoor unit		Outdoor unit	
Red LED	3 time flash	Red LED	Stays OFF
Green LED	Keeps flashing	Green LED	Keeps flashing

Flash of green LED means CPU is normal.

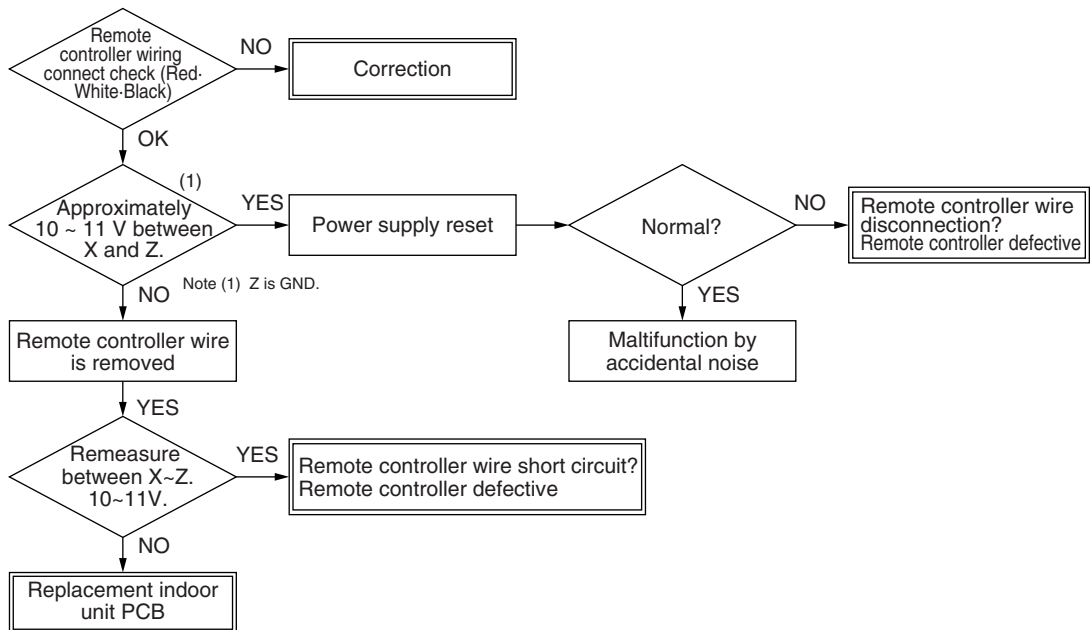

3 Error display : E1

[Communication error between remote controller~Indoor unit]

Indoor and outdoor unit	
Red LED	Stays OFF
Green LED	Keeps flashing <sup>(1)</sup>

Note (1) With the separate power supplies for indoor / outdoor units, the outdoor unit green LED may flash in some cases.

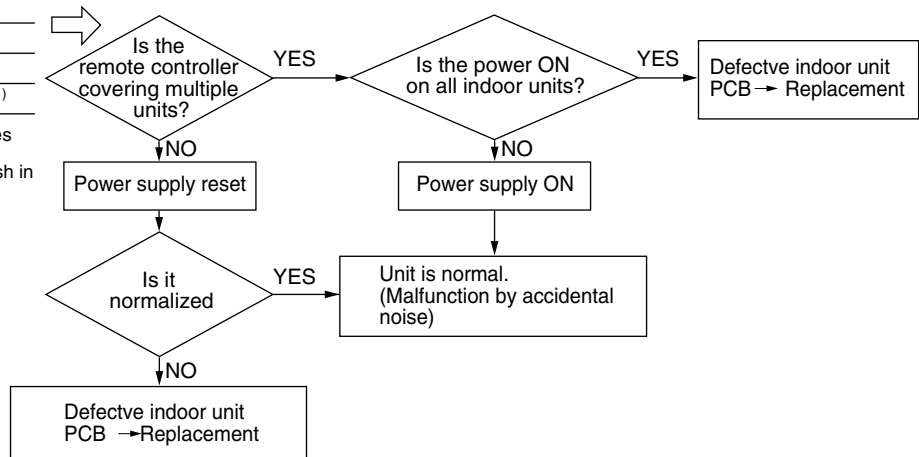

Indoor unit		Outdoor unit	
Red LED	*3 times flash	Red LED	Stays OFF
Green LED	Keeps flashing	Green LED	Keeps flashing

\* Lamp OFF if remote controller wire is broken at power ON.

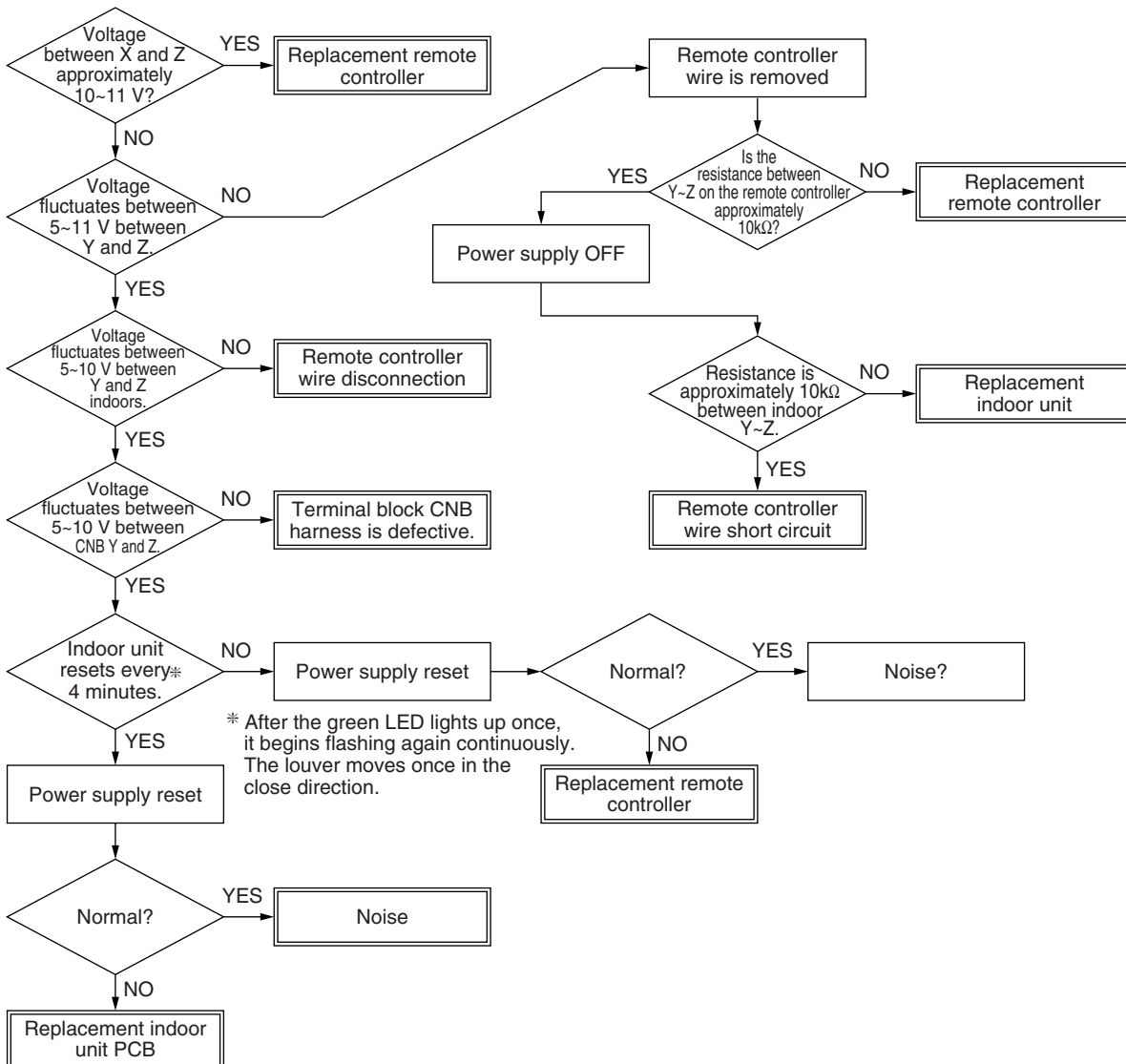

\* After the green LED lights up once, it begins flashing again continuously. The louvers move once in the close direction.

Service

Indoor unit		Outdoor unit	
Red LED	Stays OFF or Lights continuously	Red LED	Stays OFF
Green LED	Stays OFF or Lights continuously	Green LED	Keeps flashing

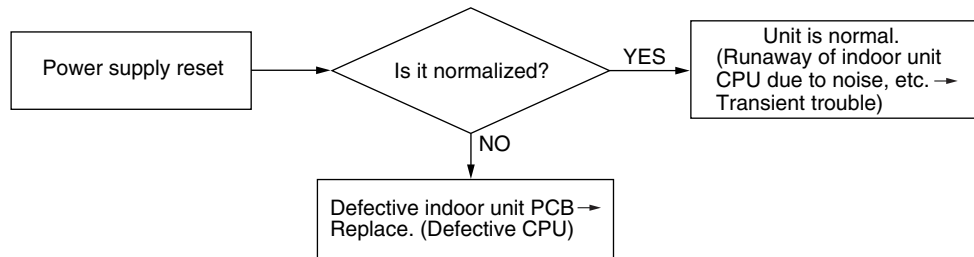

4

Error display : **E2**

[Duplicated indoor unit No. or More than 49 indoor unit are connected.]

Indoor unit		Outdoor unit	
Red LED	1 time flash	Red LED	Stays OFF
Green LED	Keeps flashing	Green LED	Keeps flashing

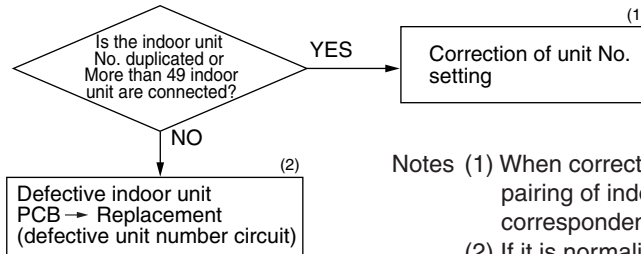

Notes (1) When correcting the unit number, check again the pairing of indoor / outdoor units (address correspondence of indoor & outdoor units) is correct.  
 (2) If it is normalized by changing PCB, judge the unit number input circuit is defective.

5

Error display : **E5**

[Defective indoor unit heat exchanger thermistor]

Indoor unit		Outdoor unit	
Red LED	1 time flash	Red LED	Stays OFF
Green LED	Keeps flashing	Green LED	Keeps flashing

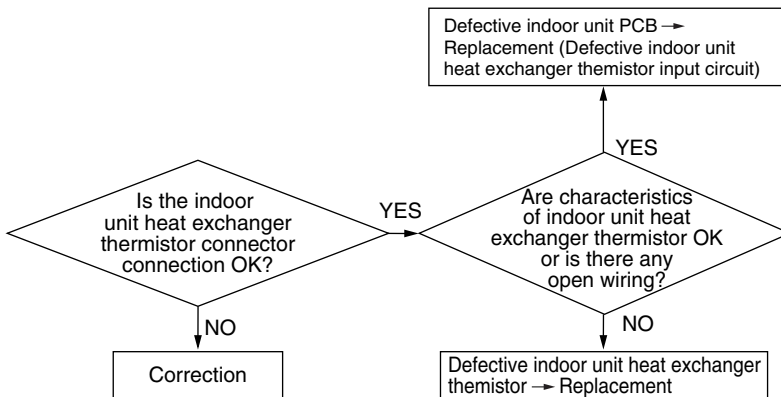

Return air thermistor (Th<sub>1</sub>-A)  
 Indoor unit heat exchanger thermistor (Th<sub>1</sub>-R1, R2, R3)  
 Resistance temperature characteristics

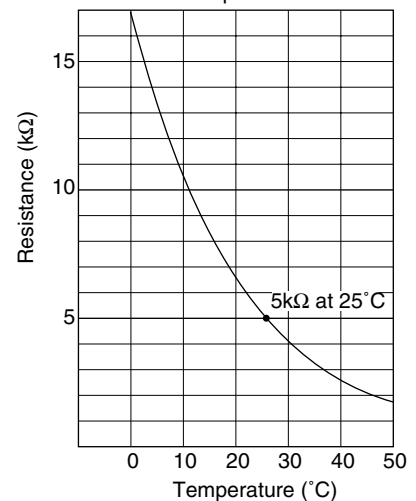

• Display Condition  
 If a temperature of -40°C or lower is detected by the thermistor continuously for 5 seconds.

Note (1) 22.5 kΩ at -6°C

6 Error display : **E7** [Detective Return air thermistor]

Indoor unit		Outdoor unit	
Red LED	1 time flash	Red LED	Stays OFF
Green LED	Keeps flashing	Green LED	Keeps flashing

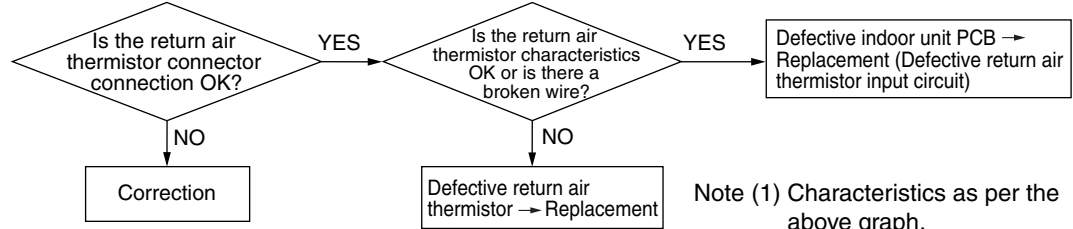

Note (1) Characteristics as per the above graph.

• Display Condition

If a temperature of -20°C or lower is detected by the thermistor continuously for 5 seconds.

7 Error display : **E9** [Drain trouble]

Indoor unit		Outdoor unit	
Red LED	1 time flash	Red LED	Stays OFF
Green LED	Keeps flashing	Green LED	Keeps flashing

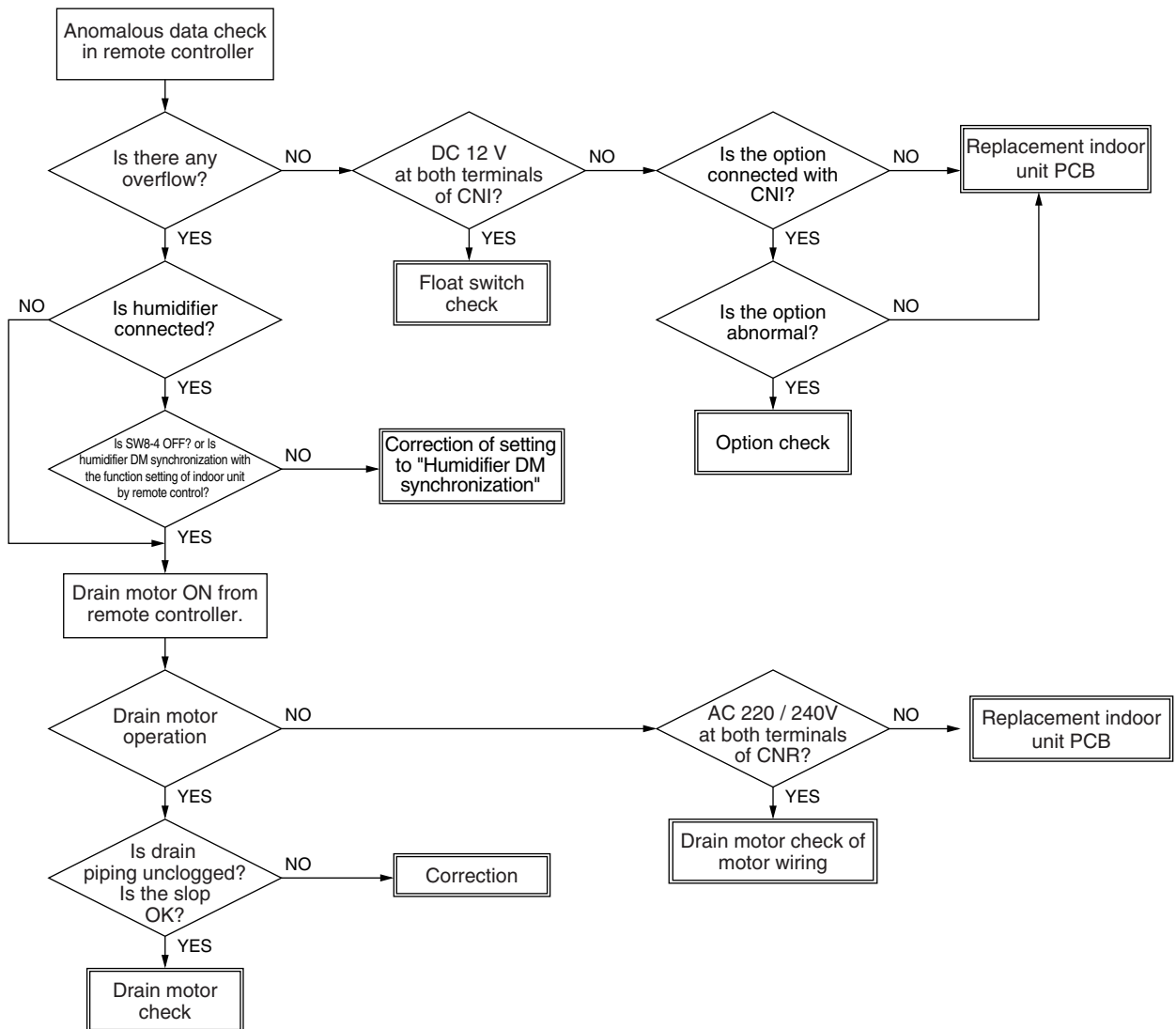

8

Error display : *E 10*

[Control of 1 remote controller VS multiple units - Excessive number of indoor units (more than 17 units)]

Indoor unit		Outdoor unit	
Red LED	Stays OFF	Red LED	Stays OFF
Green LED	Keeps flashing	Green LED	Keeps flashing

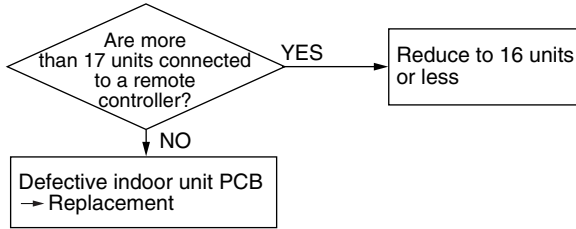

9

Error display : *E 11*

[Addresses setting for plural remote controllers]

Indoor unit		Outdoor unit	
Red LED	Stays OFF	Red LED	Stays OFF
Green LED	Keeps flashing	Green LED	Keeps flashing

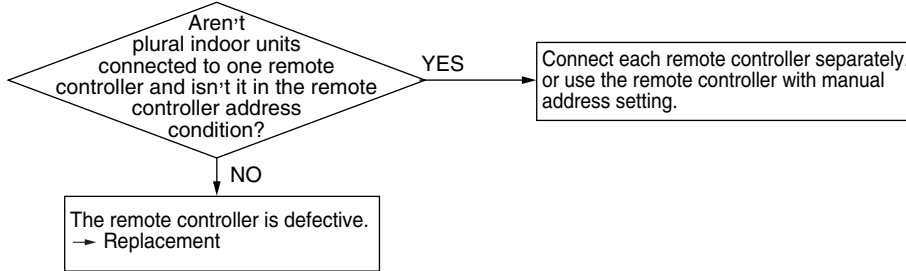

10

Error display : *E 12*

[Address No. combination error or addressing is preformed with the following combinations.]

Indoor unit		Outdoor unit	
Red LED	1 time flash	Red LED	Stays OFF
Green LED	Keeps flashing	Green LED	Keeps flashing

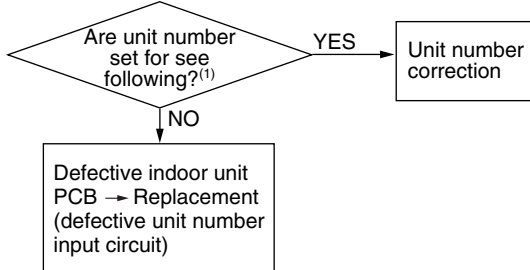

Note (1)

Outdoor unit address No.	Indoor unit address No.
00 ~ 47	48, 49
48, 49	00 ~ 47

11

Error display : **E 16**

[Indoor unit fan motor anomaly] (FDTA112, FDTA140, FDKA28 ~ 45 only)

Indoor unit		Outdoor unit	
Red LED	1 time flash	Red LED	Stays OFF
Green LED	Keeps flashing	Green LED	Keeps flashing

◆ Only case of FDT112, 140 type

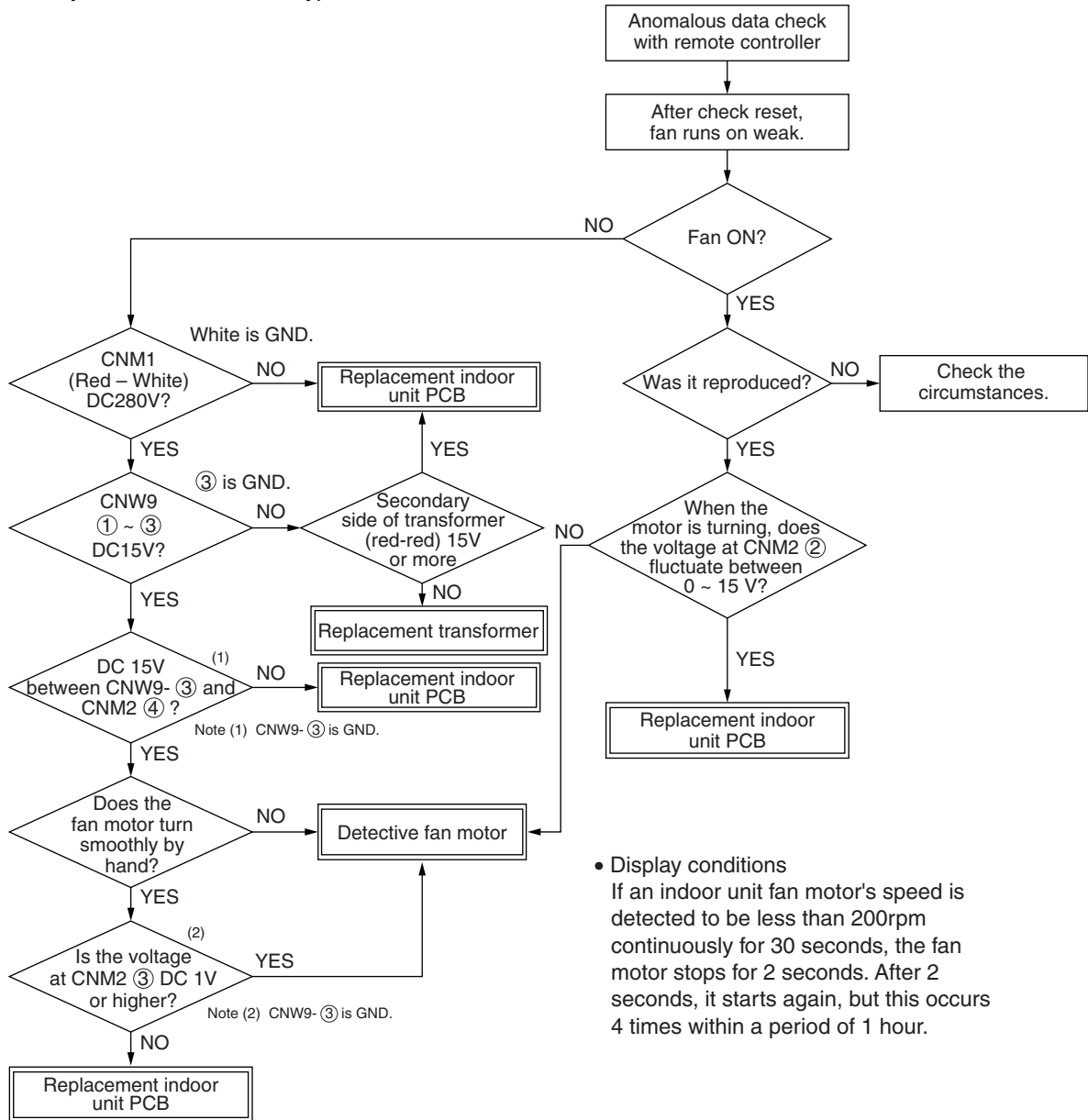

- Display conditions  
If an indoor unit fan motor's speed is detected to be less than 200rpm continuously for 30 seconds, the fan motor stops for 2 seconds. After 2 seconds, it starts again, but this occurs 4 times within a period of 1 hour.



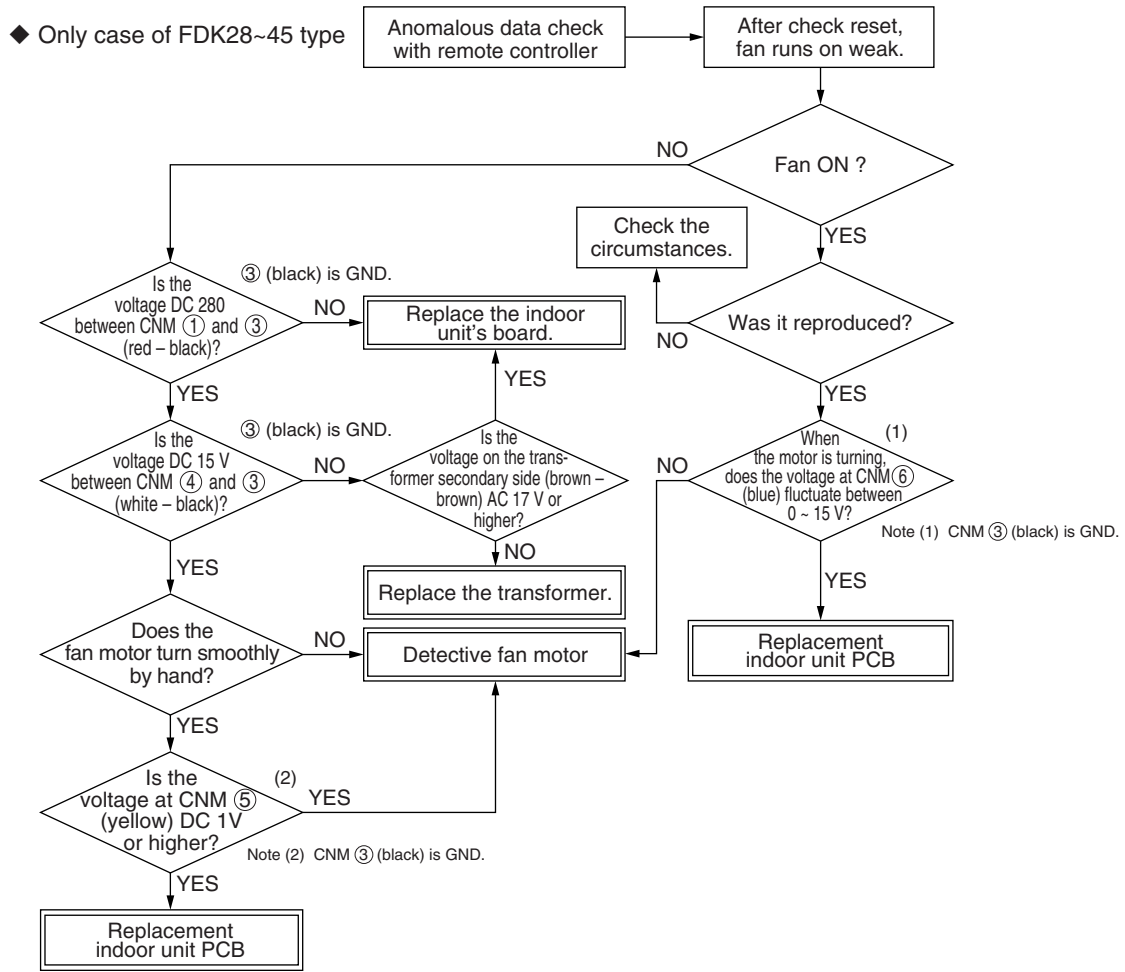

12

Error display : *E 28*

[Defective remote controller thermistor.]

Indoor unit		Outdoor unit	
Red LED	Stays OFF	Red LED	Stays OFF
Green LED	Keeps flashing	Green LED	Keeps flashing

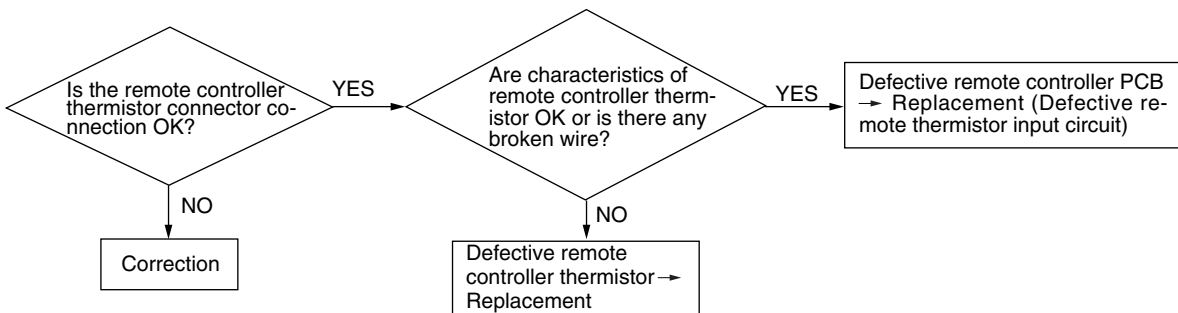

Resistance-temperature characteristic of remote controller thermistor

Temperature (°C)	Resistance value (kΩ)	Temperature (°C)	Resistance value (kΩ)	Temperature (°C)	Resistance value (kΩ)	Temperature (°C)	Resistance value (kΩ)
0	65	14	33	30	16	46	8.5
1	62	16	30	32	15	48	7.8
2	59	18	27	34	14	50	7.3
4	53	20	25	36	13	52	6.7
6	48	22	23	38	12	54	6.3
8	44	24	21	40	11	56	5.8
10	40	26	19	42	9.9	58	5.4
12	36	28	18	44	9.2	60	5.0



Name			Function	
SW4-6	ON	SW4-5	ON	Demand change (Compressor Capacity) 0%
			OFF	Demand change (Compressor Capacity) 40%
	OFF		ON	Demand change (Compressor Capacity) 60%
			OFF	Demand change (Compressor Capacity) 80%
—	SW4-7	ON	Address setup of master / slave unit-slave	
		OFF	Address setup of master / slave unit-master	

	Content
SW7	Deleting data
SW8	7 segment display Units digit
SW9	7 segment display Tens digit

		ON/OFF	Content	
SW5-1		ON	test run SW	test run
		OFF	test run SW	Normal
SW5-2		ON	test run mode	Cooling
		OFF	test run mode	Heating
SW5-3		ON	Pump down SW	Pump down
		OFF	Pump down SW	Normal
SW5-5	ON	SW5-4	ON	Length of pipe Backup
			OFF	Length of pipe shorter than 50m
	OFF		ON	Length of pipe Longer than 90m and shorter than 150m
			OFF	Length of pipe Longer than 50m and shorter than 90m

**Switching by J13 ~ 15 (With: short / None: open)**

Name		Function
J13	With	External input level
	None <sup>(1)</sup>	External input pulse
J14	With	Defrosting temp. - Normal
	None <sup>(1)</sup>	Defrosting temp. - Strengthening
J15	With	Defrosting time - Cold weather region
	None <sup>(1)</sup>	Defrosting time - Normal

**Model change over switch (SW4)**

Model	SW4				Model	SW4			
	1	2	3	4		1	2	3	4
FDCA224HKXE4	OFF	OFF	OFF	OFF	FDCA450HKXE4	ON	OFF	ON	OFF
FDCA280HKXE4	ON	OFF	OFF	OFF	FDCA504HKXE4	OFF	ON	ON	OFF
FDCA335HKXE4	OFF	ON	OFF	ON	FDCA560HKXE4	ON	ON	ON	OFF
FDCA335HKXE4-K	OFF	ON	OFF	OFF	FDCA615HKXE4	OFF	OFF	OFF	ON
FDCA400HKXE4	OFF	OFF	ON	OFF	FDCA680HKXE4	ON	OFF	OFF	ON

3. Drawing No. of spare parts for inverter PCB

Part No.	Applicable model
PCA505A062CY	FDCA140HKXEN4
PCB505A044ZD	FDCA224, 280, 335HKXE4
PCA505A062DZ	FDCA335HKXE4-K, 400HKXE4
PCB505A044ZF	FDCA450, 504, 560, 615, 680HKXE4

**FDCA140HKXEN4  
FDCA335HKXE4-K, 400HKXE4**

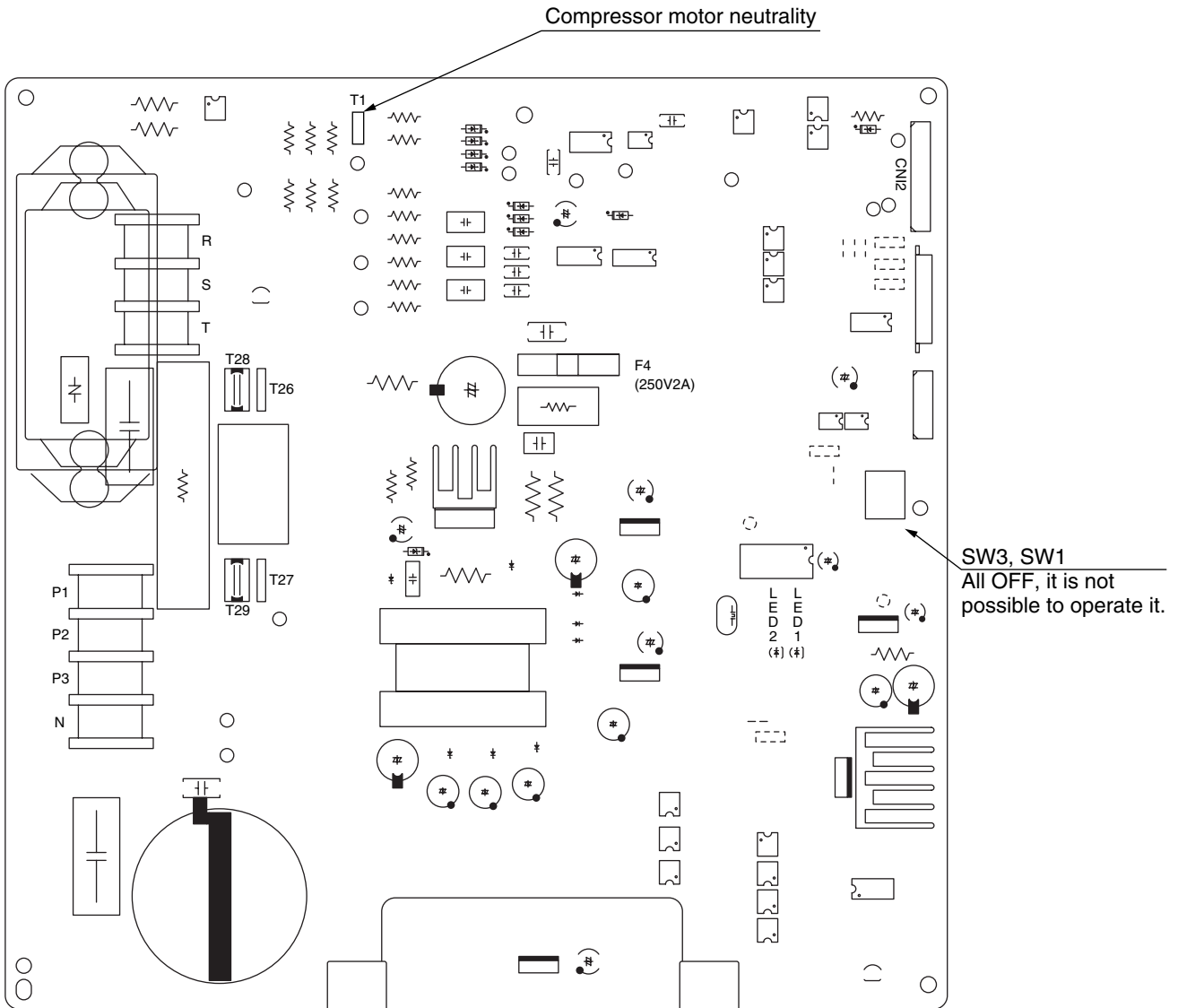

**FDCA224, 280, 335HKXE4**

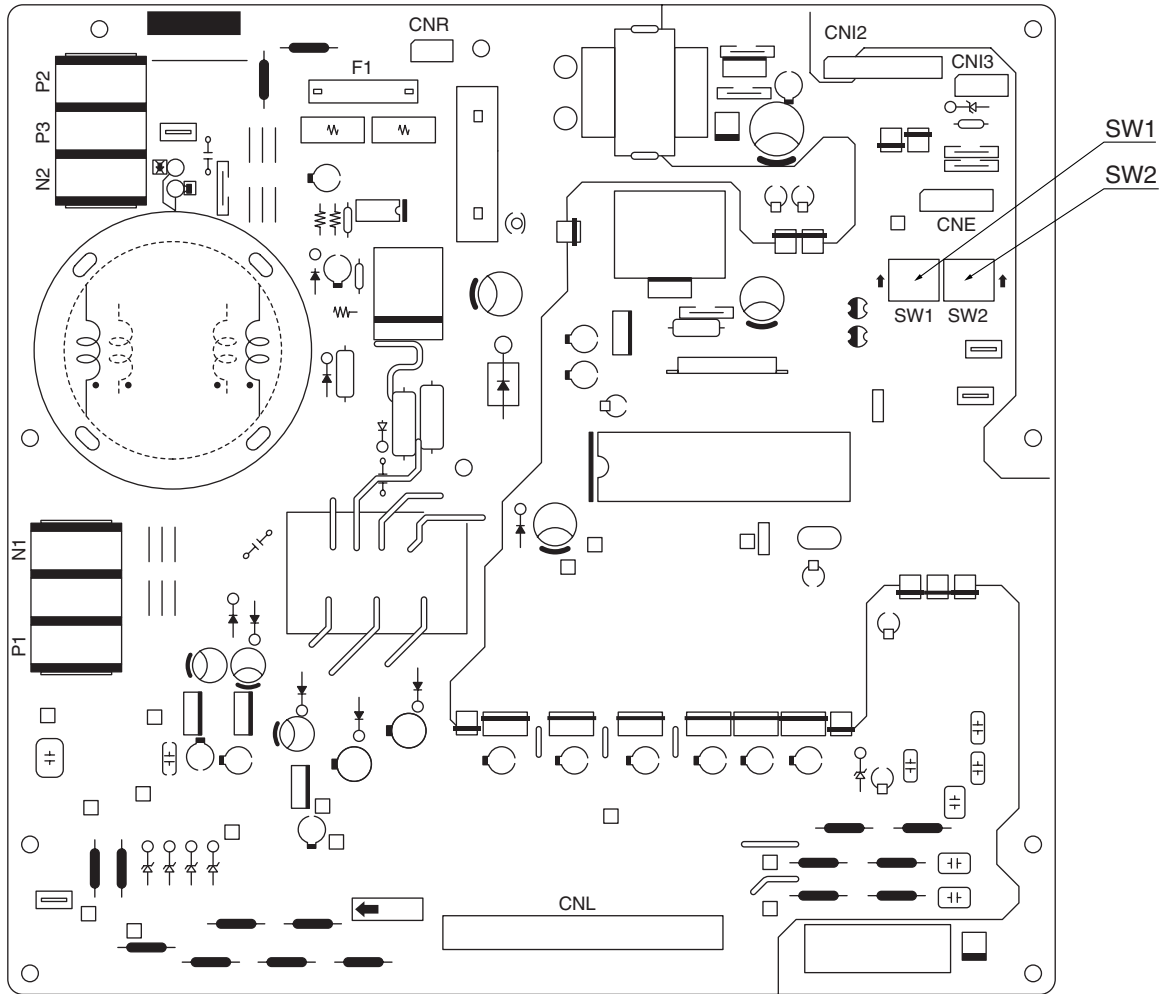

**FDCA450, 504, 560, 615, 680HKXE4**

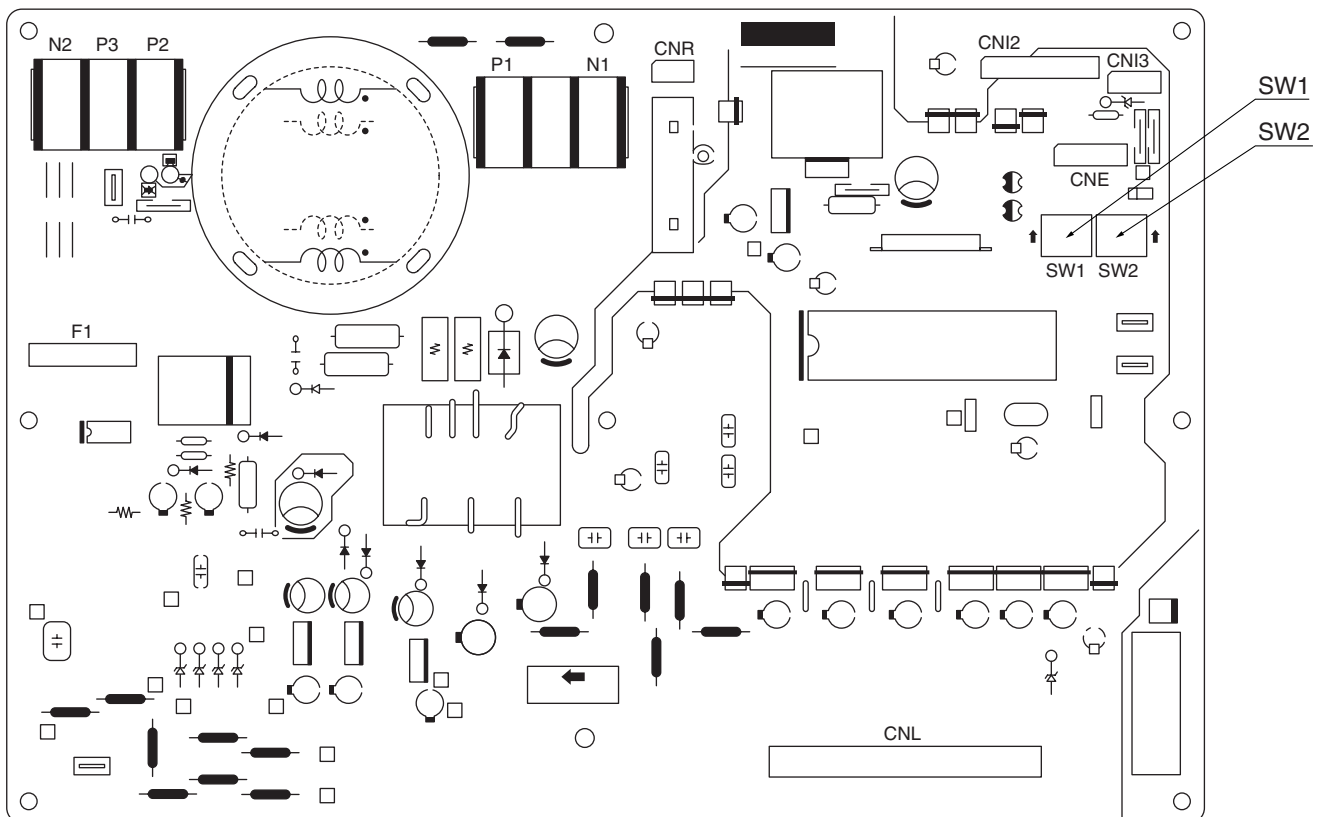

### Fault diagnosis circuit diagram for outdoor unit controller

◆ 140 type

■ Check points for outdoor unit

Please check the items marked with \* under the condition of power supply ON.

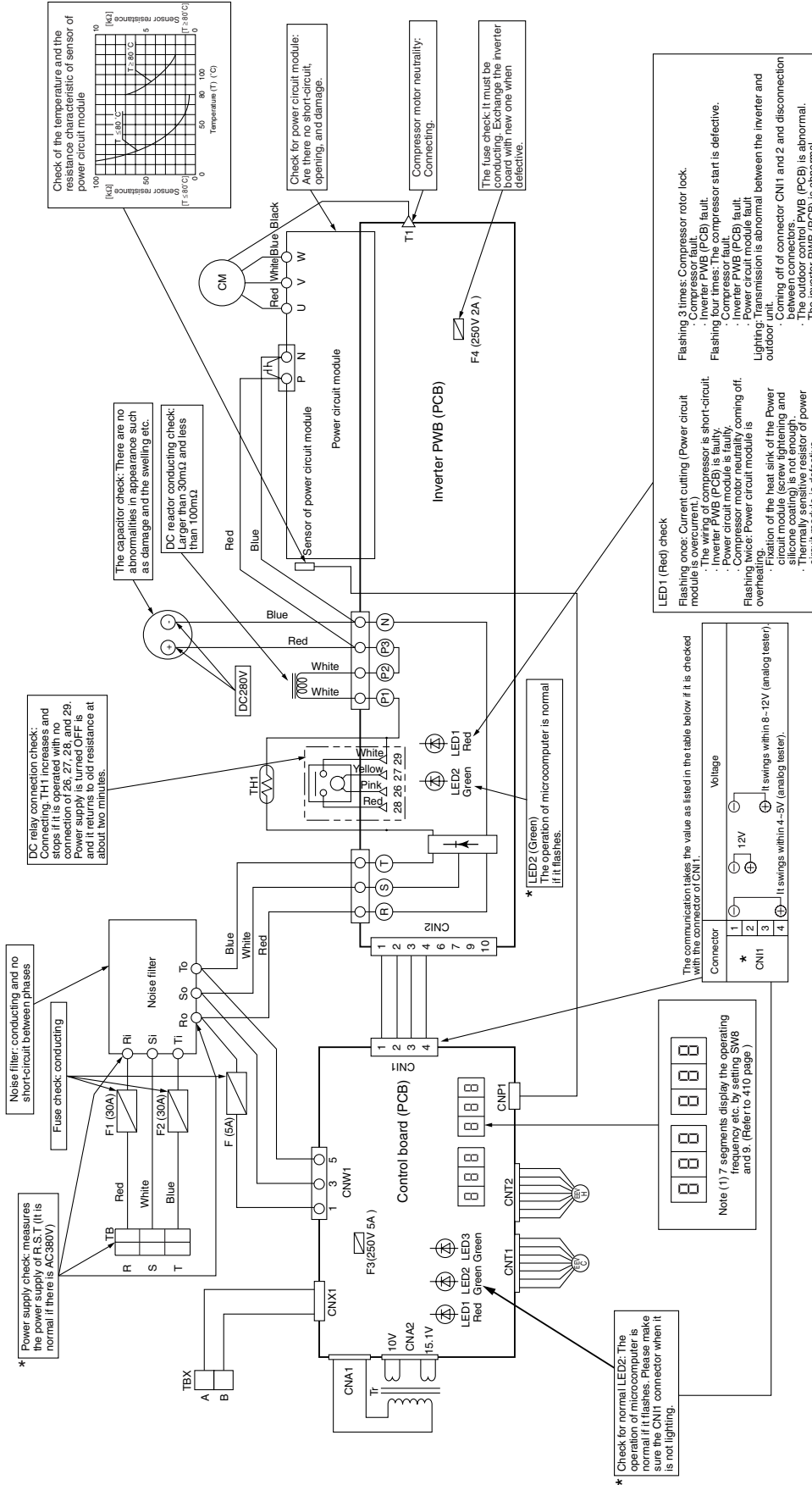

224, 280, 335, 450, 504, 560, 615, 680 type (This diagram shows 224~335 type, as for 450~680 type, the system related to the inverter becomes two systems.)

- Check points for outdoor unit  
Please check the items marked with \* under the condition of power supply ON.

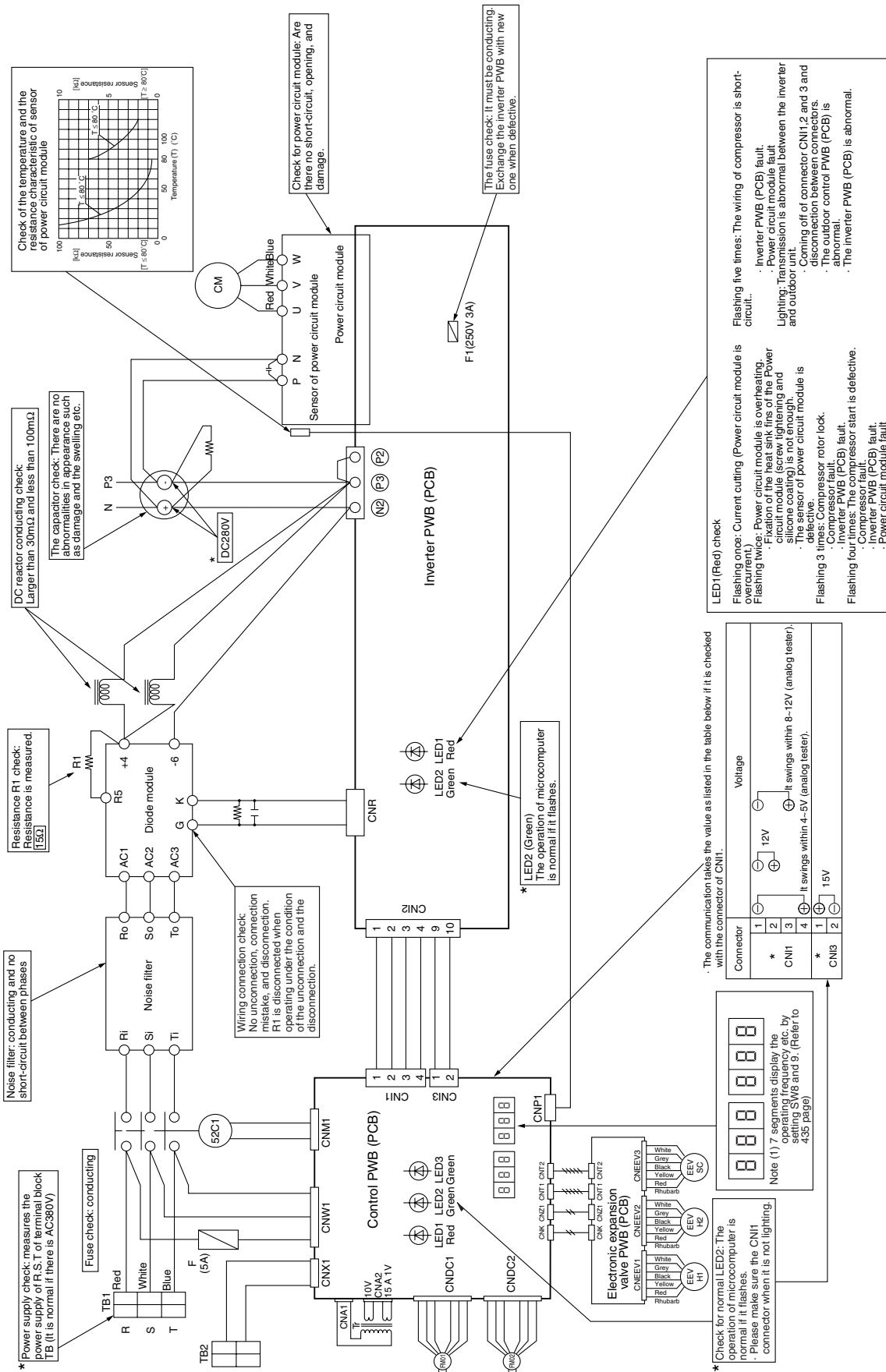





4. Check procedure depending on indication lamps (For the outdoor unit)

1 Error display : E3 [Error on the outdoor unit signal wire]

(Detected during operation only)

Indoor unit	
Red LED	2 time flash
Green LED	Keeps flashing

Outdoor unit	
Red LED	Stays OFF
Green LED	Stays OFF

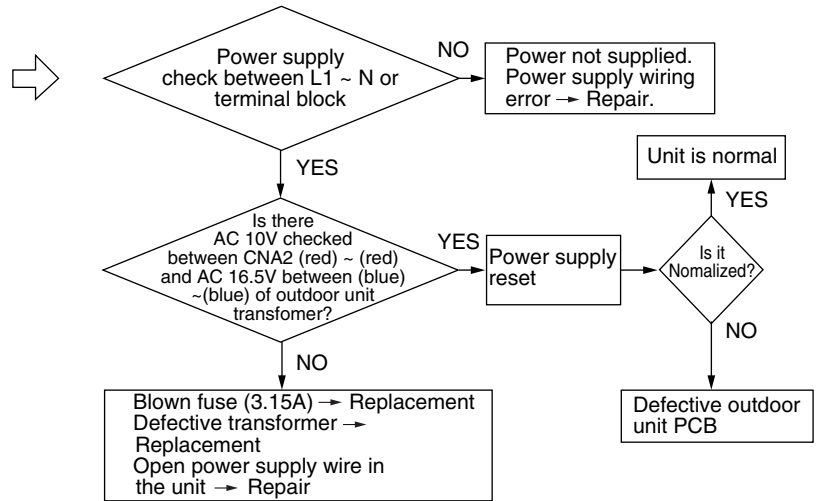

Indoor Unit	Red•LED	2 time flash	Outdoor Unit	Red•LED	Stays OFF
	Green•LED	Keeps flashing		Green•LED	Keeps flashing

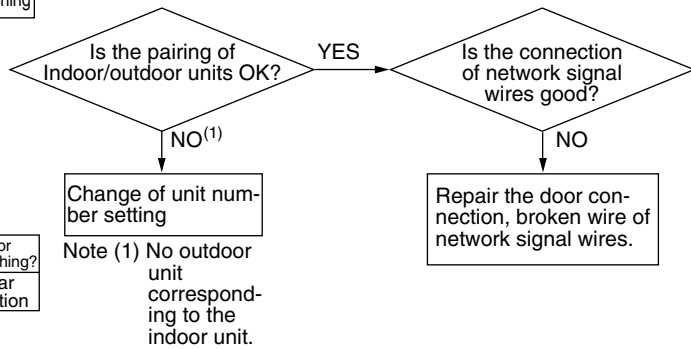

Indoor Unit	Red•LED	2 time flash	Outdoor Unit	Red•LED	Lights or keeps flashing?
	Green•LED	Keeps flashing		Green•LED	Irregular illumination

Note (1) so-called irregular illumination means that the flashing pattern is any type of illumination excluding illumination.

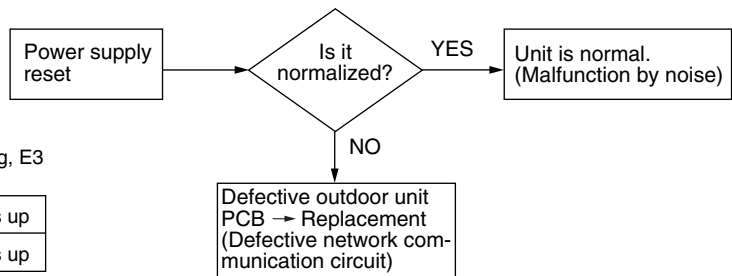

Remark When the signal from indoor unit is loop wiring, E3 might be displayed.

Indoor Unit	Red•LED	2 time flash	Outdoor Unit	Red•LED	Lights up
	Green•LED	Keeps flashing		Green•LED	Lights up

2 Error display : E 5 [Outdoor unit signal wire error, power supply error]

Indoor unit	
Red LED	2 time flash
Green LED	Keeps flashing

  

Outdoor unit	
Red LED	Stays OFF
Green LED	Stays OFF

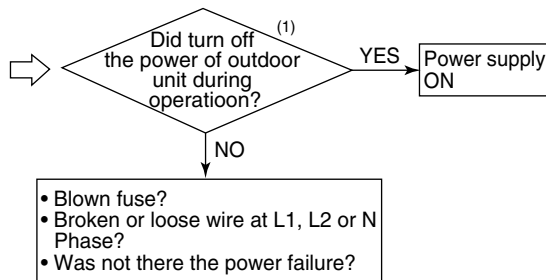

Note (1) This case is limited to the separate power supplies to indoor / outdoor units. (Combination of (indoor unit) red LED 2 time flash and (outdoor unit) green LED stays off means that the power supply to the outdoor unit has been interrupted during operation.)

Indoor Unit	Red-LED	2 time flash	Outdoor unit	Red-LED	Stays OFF or Keeps flashing
	Green-LED	Keeps flashing		Green-LED	Irregular illumination

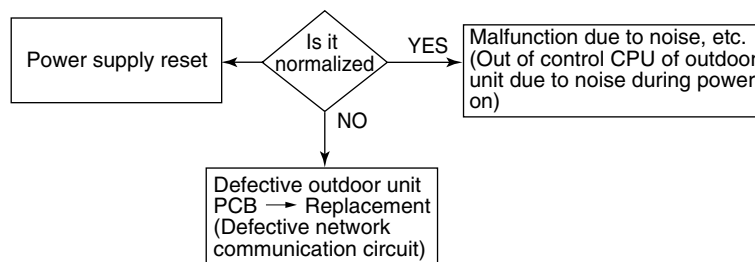

Indoor Unit	Red-LED	2 time flash	Outdoor unit	Red-LED	Stays OFF
	Green-LED	Keeps flashing		Green-LED	Keeps flashing

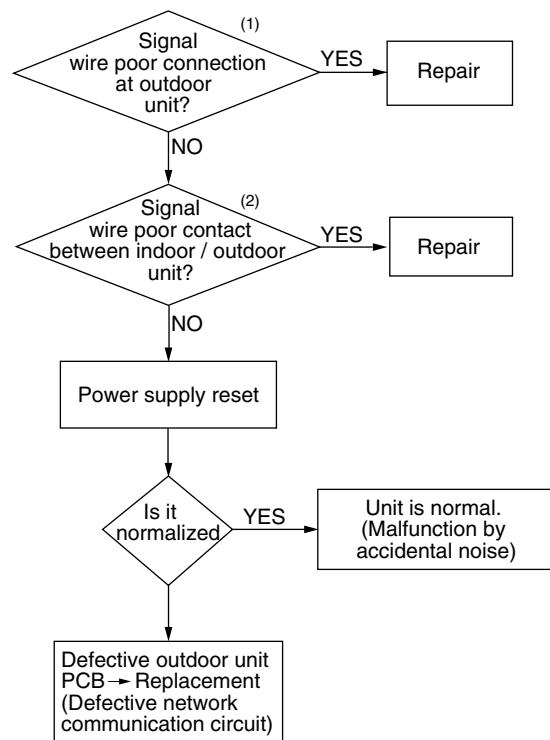

Notes (1) Check for poor connection (looseness, misconnection) at outdoor unit terminal block and open signal wires between outdoor units.  
 (2) Check the poor connection or broken signal wires between indoor / outdoor units.

3 Error display : *E 30* [Connection error indoor and outdoor unit]  
 7-segment display : *E 30*

Indoor unit		Outdoor unit	
Red LED	Stays OFF	Red LED	1 time flash
Green LED	Keeps flashing	Green LED	Keeps flashing

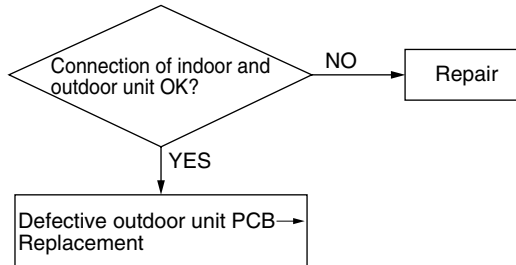

4 Error display : *E 31* [Duplicated unit No. of outdoor units]  
 7-segment display : *E 31*

Indoor unit		Outdoor unit	
Red LED	Stays OFF	Red LED	1 time flash
Green LED	Keeps flashing	Green LED	Keeps flashing

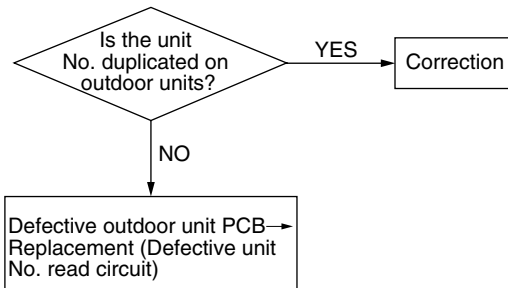

5 Error display : *E 32* [Open phase or open 52C L3 phase (primary side) on power supply]  
 7-segment display : *E 32*

Indoor unit		Outdoor unit	
Red LED	Stays OFF	Red LED	1 time flash <sup>(1)</sup>
Green LED	Keeps flashing	Green LED	Keeps flashing

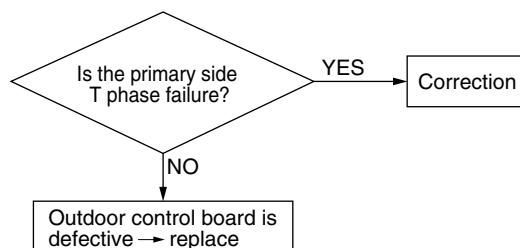

6 Error display : **E 35** [Air-conditioning overload operating][Only FDCA140 and HKXE4]  
 7-segment display : **E 35**

Indoor	Red-LED	Turning off	Outdoor	Red-LED	Flashing once
	Green-LED	Continuously flashing		Green-LED	Continuously flashing

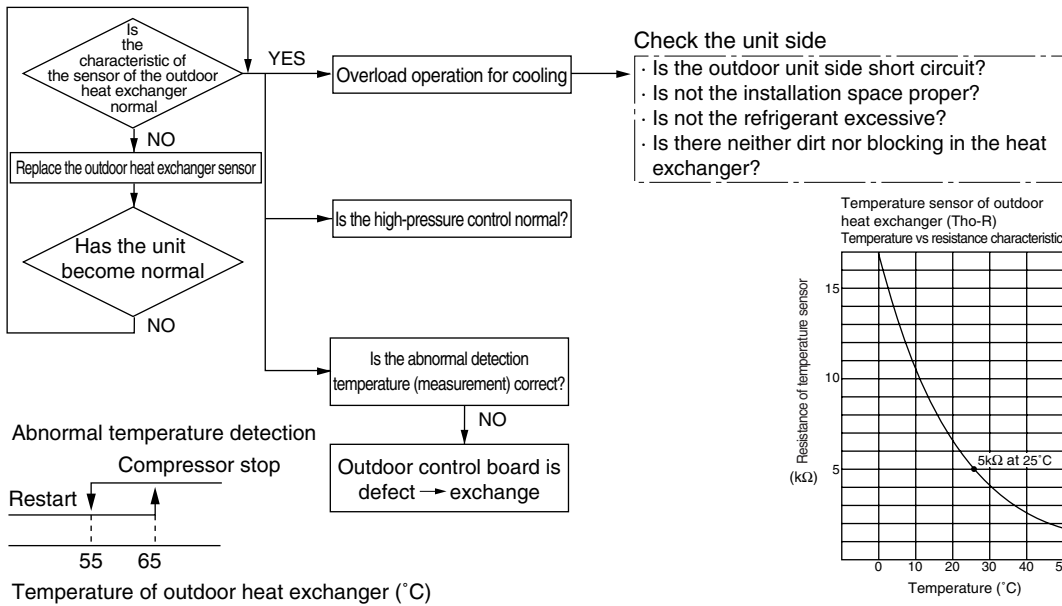

7 Error display : **E 36** [Discharge temperature error]  
 7-segment display : **E 36-1**  
**E 36-2**

Indoor unit		Outdoor unit	
Red LED	Stays OFF	Red LED	1 time flash <sup>(1)</sup>
Green LED	Keeps flashing	Green LED	Keeps flashing

Note (1): Single flashing of outdoor unit LED indicates Tho-D1 and double flashing indicates Tho-D2.

• Anomalous temperature detection

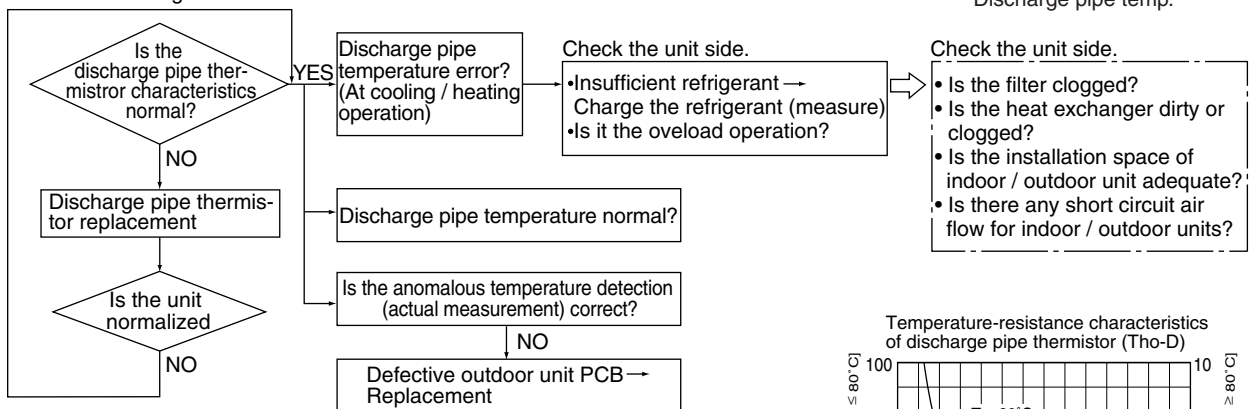
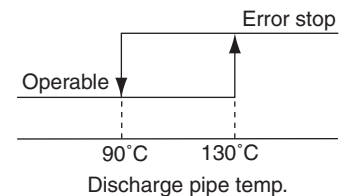

8

Error display : *E 37*  
 7-segment display : *E 37-1*  
*E 37-2*  
*E 37-3*  
*E 37-4*  
*E 37-5*  
*E 37-6*

[Defective outdoor unit heat exchanger and sub-cooling coil thermistor]

Indoor unit		Outdoor unit	
Red LED	Stays OFF	Red LED	1 time flash <sup>(1)</sup>
Green LED	Keeps flashing	Green LED	Keeps flashing

Note (1) Tho-R1 flashes 1 time (*E37, E37-1*) Tho-R2 flashes 2 times (*E37-2*), Tho-R3 flashes 3 times, Tho-R4 flashes 4 times, Tho-SH2 flashes 5 times, Tho-H flashes 6 times.

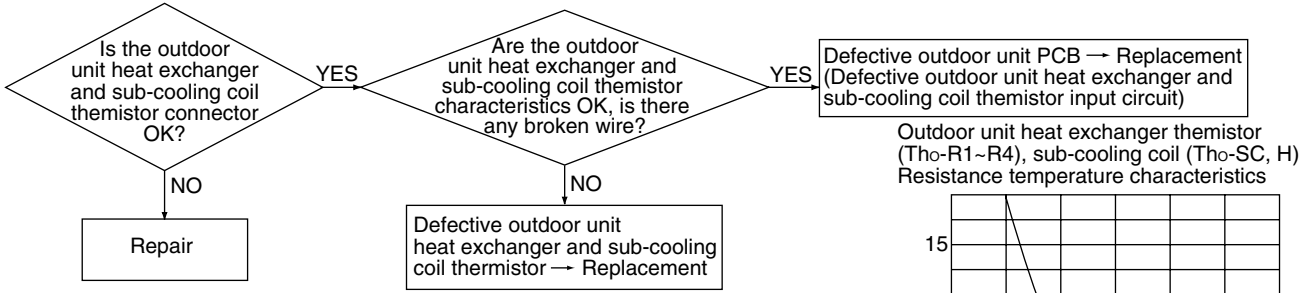

Outdoor unit heat exchanger thermistor (Tho-R1~R4), sub-cooling coil (Tho-SC, H) Resistance temperature characteristics

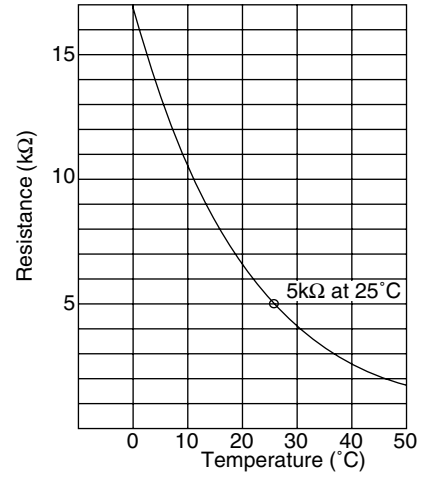

- Display conditions  
 If the temperature sensed by the thermistor is -50°C or lower continuously for 5 seconds between 2 minutes and 2 minutes 20 seconds after the compressor goes ON, the compressor stops. After a 3 minute delay, the compressor restarts. If this state is detected 3 times in 40 minutes.

9

Error display : *E 38*  
 7-segment display : *E 38*

[Defective outdoor temperature thermistor]

Indoor unit		Outdoor unit	
Red LED	Stays OFF	Red LED	1 time flash
Green LED	Keeps flashing	Green LED	Keeps flashing

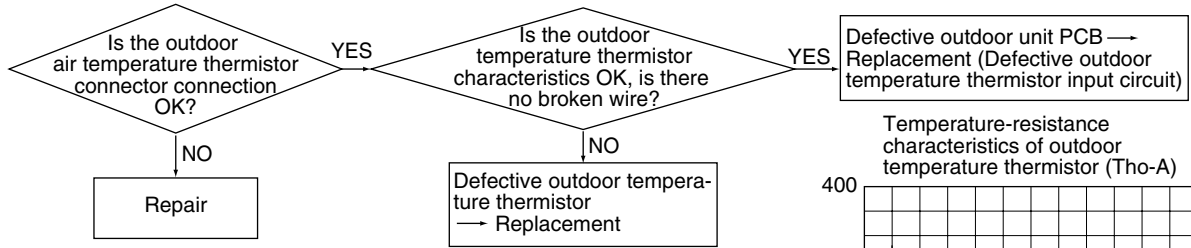

Temperature-resistance characteristics of outdoor temperature thermistor (Tho-A)

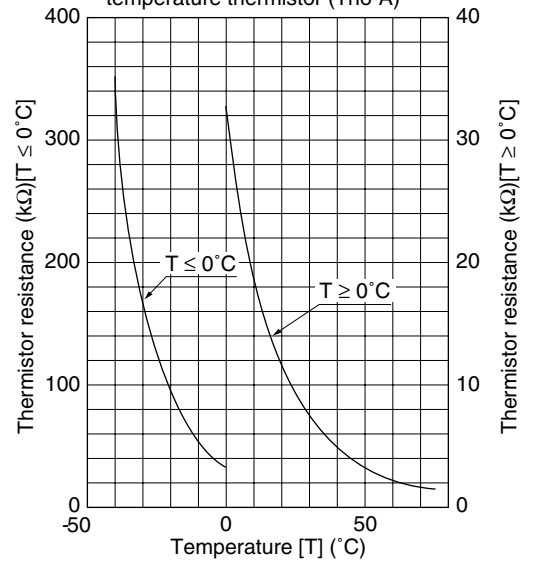

10

Error display : <i>E 39</i>
7-segment display : <i>E 39-1</i> <i>E 39-2</i>

[Defective discharge pipe thermistor]

Indoor unit		Outdoor unit	
Red LED	Stays OFF	Red LED	1 time flash <sup>(1)</sup>
Green LED	Keeps flashing	Green LED	Keeps flashing

Note (1) Single flashing of outdoor unit LED indicates Tho-D1 (*E39, E39-1*) and double flashing (*E39-2*) indicates Tho-D2.

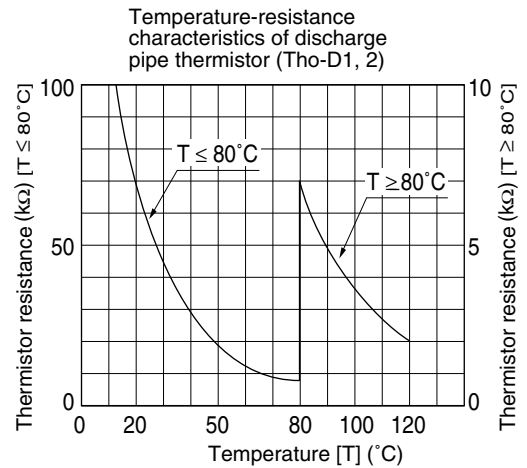
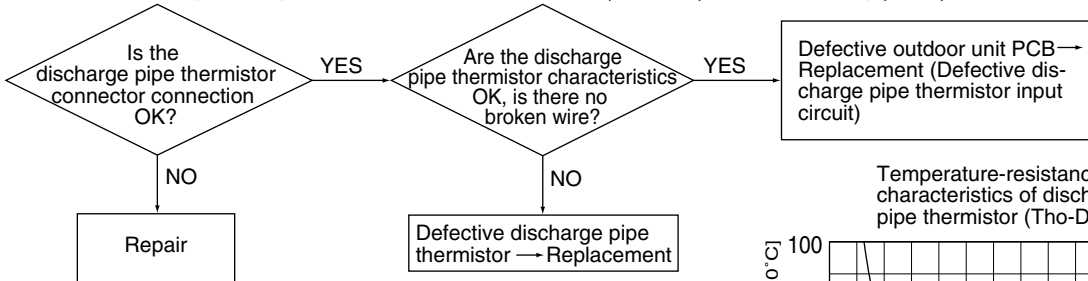

11

Error display : <i>E 40</i>
7-segment display : <i>E 40</i>

[63H1-1,2, motion]

Indoor unit		Outdoor unit	
Red LED	Stays OFF	Red LED	1 time flash
Green LED	Keeps flashing	Green LED	Keeps flashing

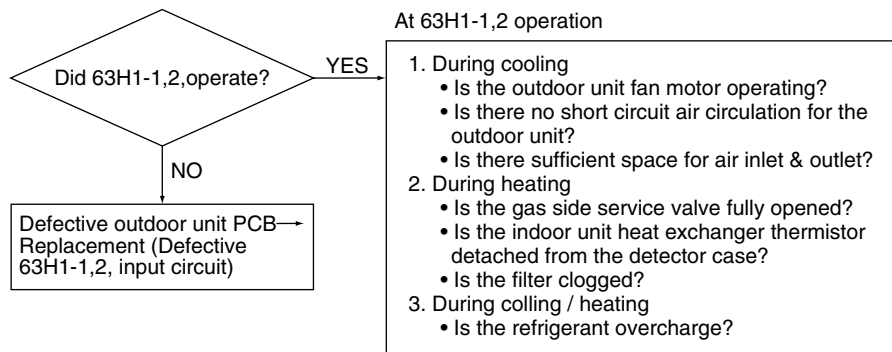

• 140 type

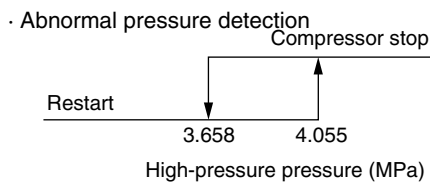

• 224 ~ 680 type

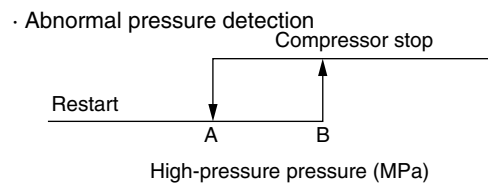

Model	High-pressure pressure (MPa)	
	A	B
FDCA224HKXE4 ~ 335HKXE4	2.90	3.80
FDCP335HKXE4-K FDCP400HKXE4 ~ 680HKXE4	3.15	4.15

12

Error display : E 47
7-segment display : E 47-1 E 47-2

[Power transistor overheating]

Indoor unit		Outdoor unit	
Red LED	Stays OFF	Red LED	1 time flash <sup>(1)</sup>
Green LED	Keeps flashing	Green LED	Keeps flashing

Note (1) Single flashing of outdoor unit LED indicates power transistor (CM1) overheat and double flashing indicates power transistor (CM2) overheat.

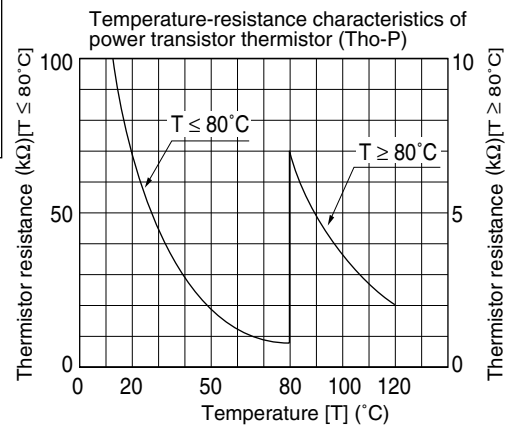
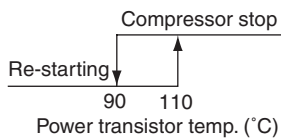
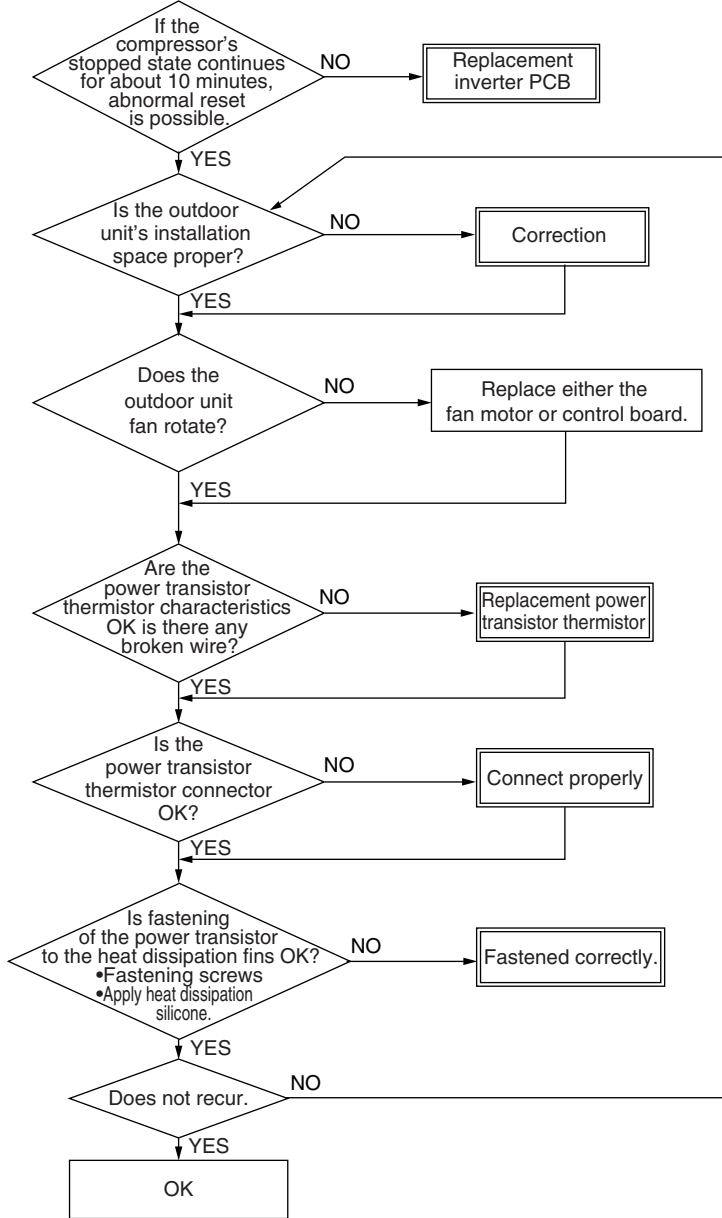

13

Error display : E 42
7-segment display : E 42-1
E 42-2

[Current cut]

Indoor unit		Outdoor unit	
Red LED	Stays OFF	Red LED	1 time flash <sup>(1)</sup>
Green LED	Keeps flashing	Green LED	Keeps flashing

Note (1) Single flashing of outdoor unit LED indicates current cut (CM1) and double flashing indicates current cut (CM2).

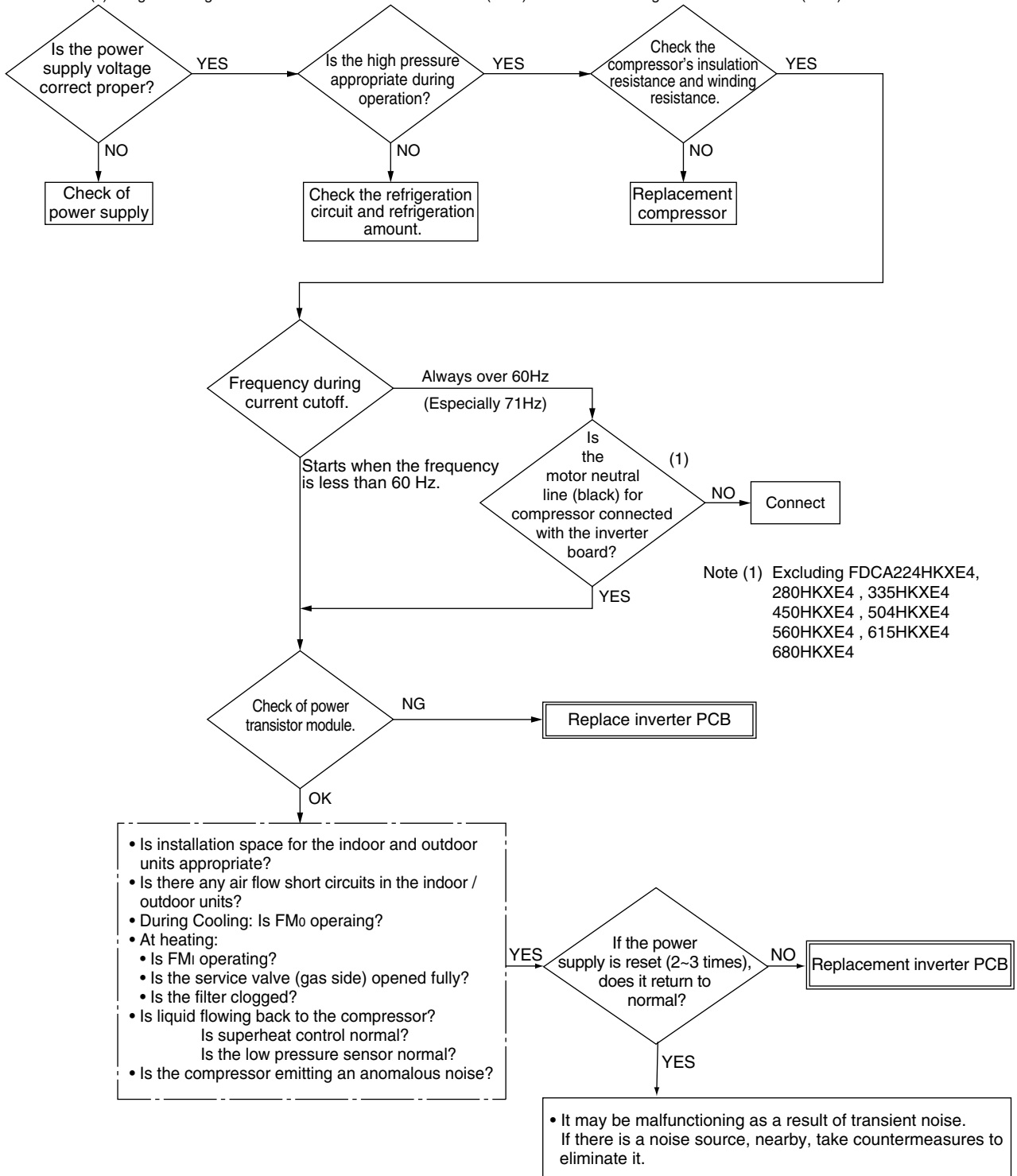

Note (1) Excluding FDCA224HKXE4, 280HKXE4, 335HKXE4, 450HKXE4, 504HKXE4, 560HKXE4, 615HKXE4, 680HKXE4

Service



14

Error display : *E 43*  
7-segment display : *E 43*

[Excessive number of indoor units connected]

Indoor unit		Outdoor unit	
Red LED	Stays OFF	Red LED	1 time flash
Green LED	Keeps flashing	Green LED	Keeps flashing

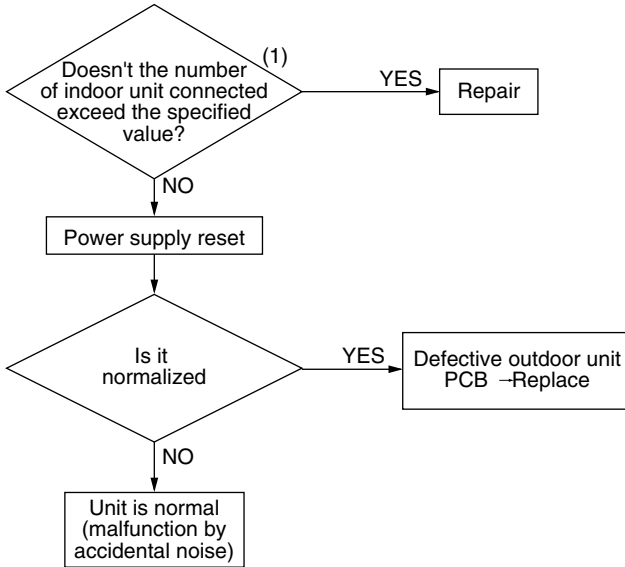

Notes (1) Outdoor No. setting check for indoor units (to see if outdoor No. is of other system)  
(2) In case of auto addressing erase the addresses stored in memory and perform re-setting

15

Error display : *E 45*  
7-segment display : *E 45-1*  
*E 45-2*

[Transmission error between inverter and Outdoor unit PCB]

Indoor unit		Outdoor unit	
Red LED	Stays OFF	Red LED	1 time flash (1)
Green LED	Keeps flashing	Green LED	Keeps flashing

Note (1) Single flashing of outdoor unit LED indicates transmission error between inverter and outdoor unit PCB (CM1).  
Double flashing of outdoor unit LED indicates transmission error between inverter and outdoor unit PCB (CM2).

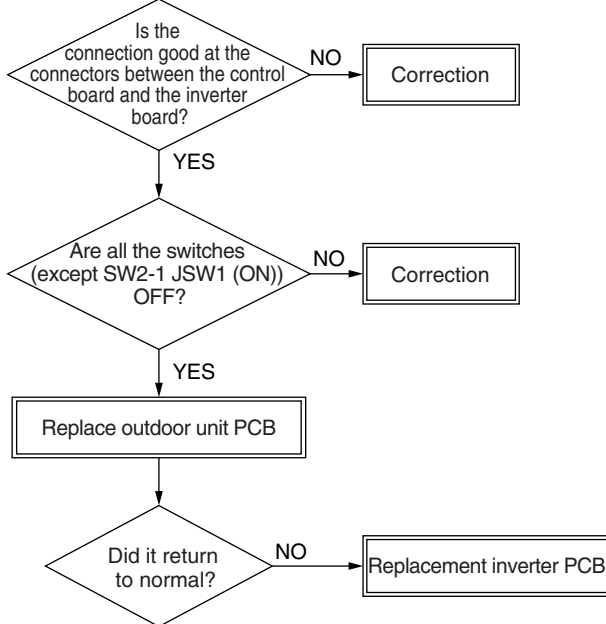

16

Error display : *E 46*  
 7-segment display : —

[ Automatic address setting and remote controller address setting coexist in the same network ]

Indoor unit		Outdoor unit	
Red LED	Stays OFF	Red LED	Stays OFF
Green LED	Keeps flashing	Green LED	Keeps flashing

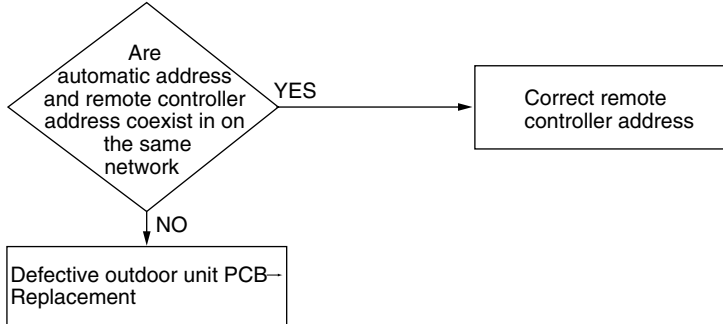

17

Error display : *E 48*  
 7-segment display : *E 48-1*  
                           *E 48-2*

[Abnormalities in an outdoor fan motor] [224 ~ 680 type only]

Indoor unit		Outdoor unit	
Red LED	Stays OFF	Red LED	1 time flash <sup>(1)</sup>
Green LED	Keeps flashing	Green LED	Keeps flashing

Note (1) Single flashing of outdoor unit LED indicates FM01 and double flashing indicates FM02.

• When outdoor unit is running

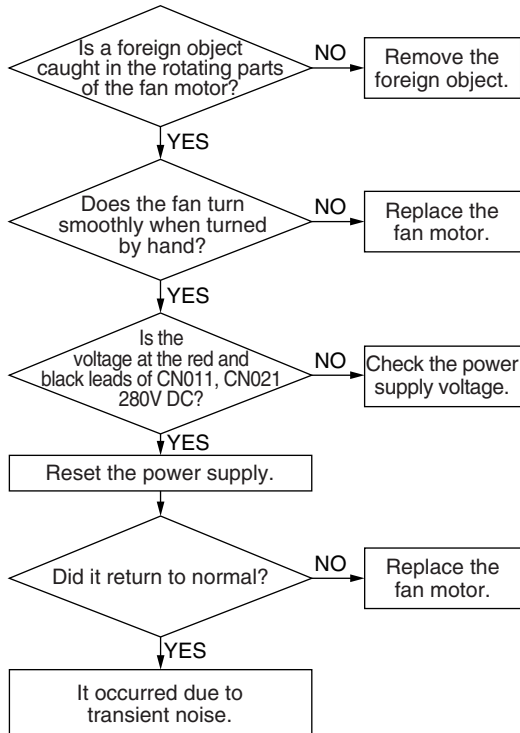

18

Error display : *E 49*  
7-segment display : *E 49*

[Low pressure anomaly]

Indoor unit		Outdoor unit	
Red LED	Stays OFF	Red LED	1 time flash
Green LED	Keeps flashing	Green LED	Keeps flashing

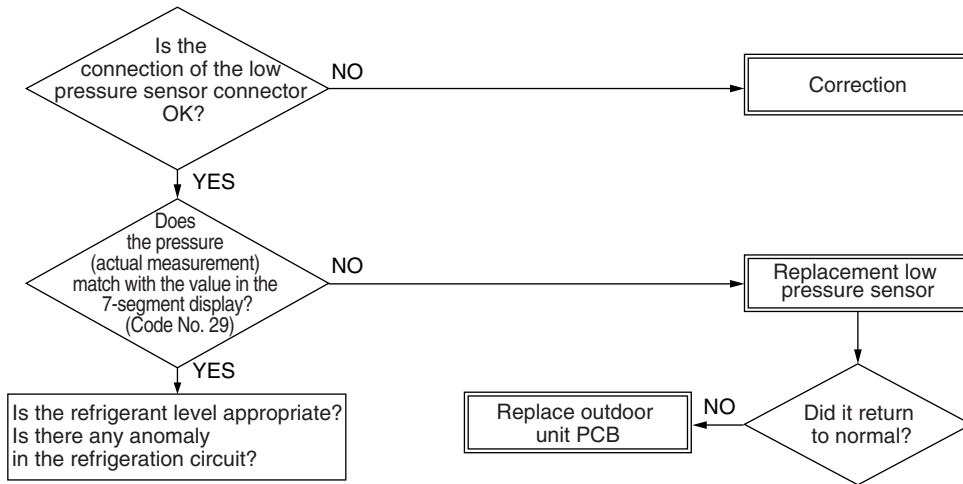

• 140 type

Anomalous pressure detection

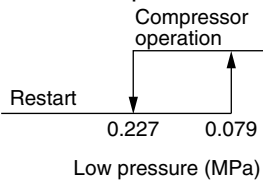

• 224 ~ 680 type

Anomalous pressure detection

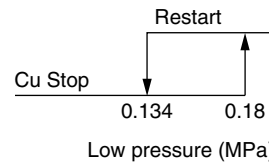

19

Error display : *E 53*  
7-segment display : *E 53*

[Defective suction pipe temperature thermistor]

Indoor unit		Outdoor unit	
Red LED	Stays OFF	Red LED	1 time flash
Green LED	Keeps flashing	Green LED	Keeps flashing

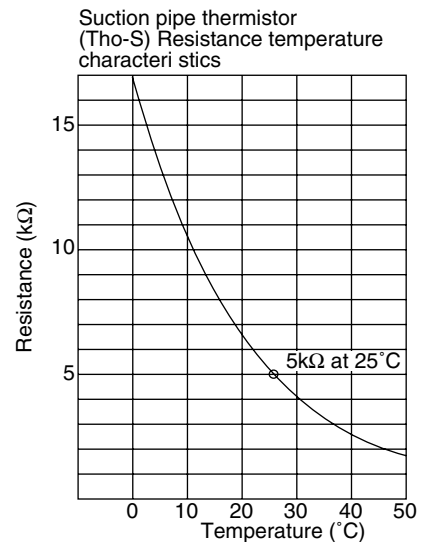
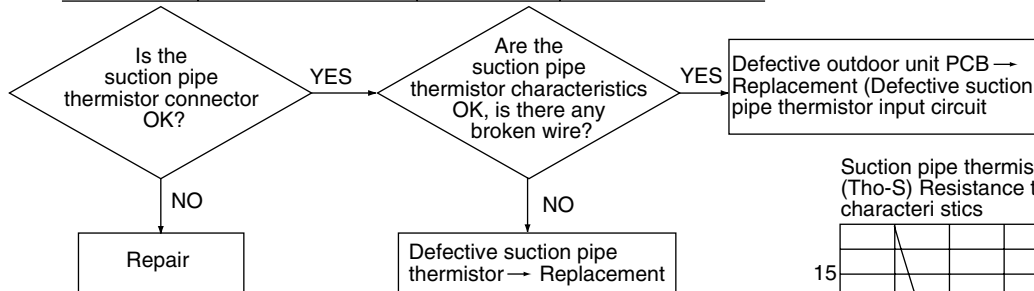

20

Error display : <i>E 54</i>
7-segment display : <i>E 54-1</i> <i>E 54-2</i>

[Defective low pressure and high pressure sensor]

Indoor unit		Outdoor unit	
Red LED	Stays OFF	Red LED	1 time flash <sup>(1)</sup>
Green LED	Keeps flashing	Green LED	Keeps flashing

Note (1) Flashing once when the low-pressure pressure sensor is defective.  
Flashing twice when the high-pressure pressure sensor is defective.

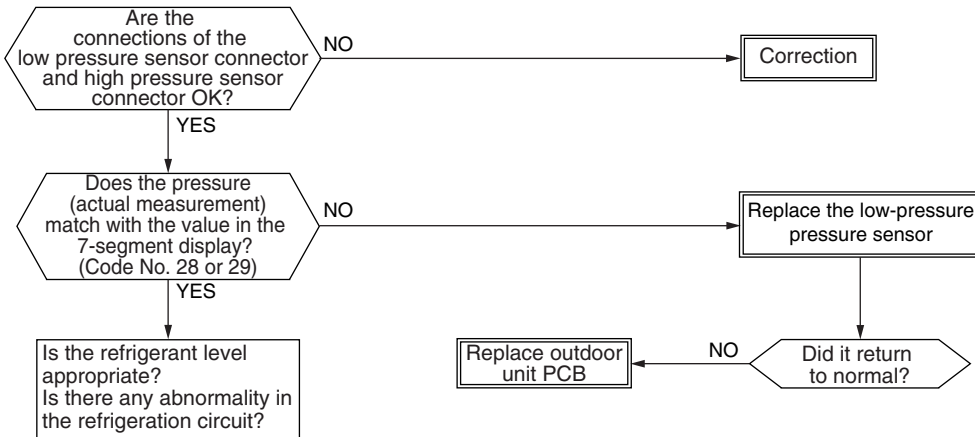

21

Error display : <i>E 59</i>
7-segment display : <i>E 59-1</i> <i>E 59-2</i>

[Anomaly in compressor starting]

Indoor unit		Outdoor unit	
Red LED	Stays OFF	Red LED	1 time flash <sup>(2)</sup>
Green LED	Keeps flashing	Green LED	Keeps flashing

Notes (1) Check if the power supply system is normal.  
(2) Single flashing of outdoor unit LED indicates abnormalities in compressor (CM1) starting and double flashing indicates abnormalities in compressor (CM2) starting.

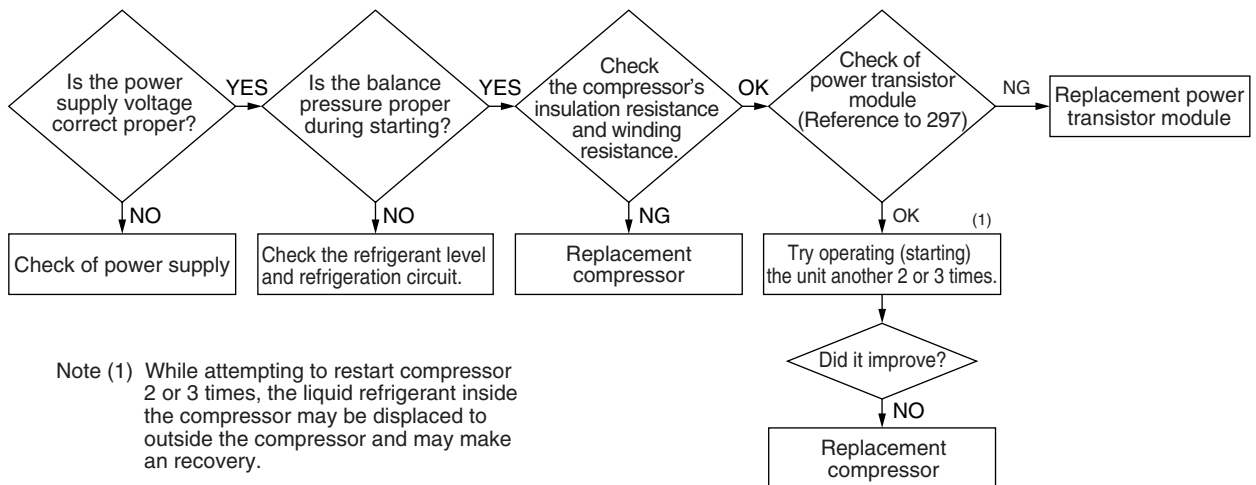

Note (1) While attempting to restart compressor 2 or 3 times, the liquid refrigerant inside the compressor may be displaced to outside the compressor and may make a recovery.

22

Error display : <i>E 60</i>
7-segment display : <i>E 60-1</i> <i>E 60-2</i>

[Compressor rotor position detection error]

Indoor unit		Outdoor unit	
Red LED	Stays OFF	Red LED	1 time flash <sup>(2)</sup>
Green LED	Keeps flashing	Green LED	Keeps flashing

Notes (1) Check if the power supply system is normal.

(2) Single flashing of outdoor unit LED indicates compressor (CM1) loader position detection error and double flashing indicates compressor (CM2) loader position detection error.

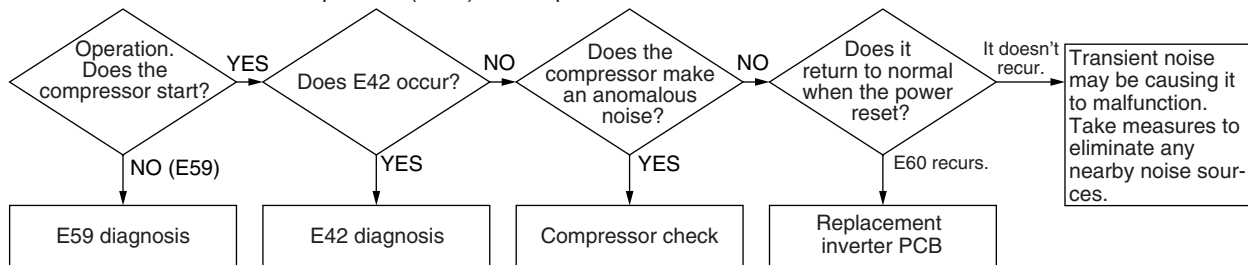

• Display conditions

- (1) After rotor position detection operation, if the rotor's position cannot be detected again (4 times in 15 minutes), an error is displayed.
- (2) A remote control reset is possible after 3 minutes passes.

23

Error display : <i>E 63</i>
7-segment display : <i>E 63</i>

[Scram] [224 ~ 680 type only]

Indoor unit		Outdoor unit	
Red LED	Stays OFF	Red LED	1 time flash
Green LED	Keeps flashing	Green LED	Keeps flashing

Note (1) Check if the power supply system is normal.

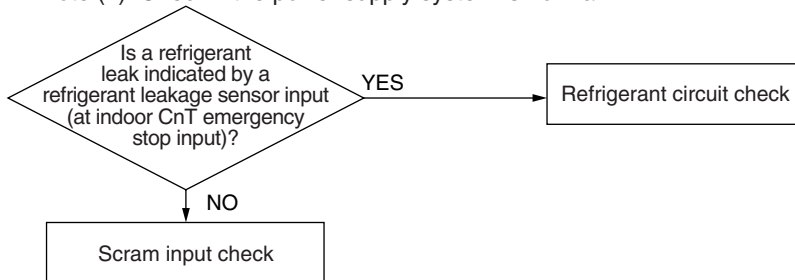

## Checking the power transistor module (including the drive circuit)

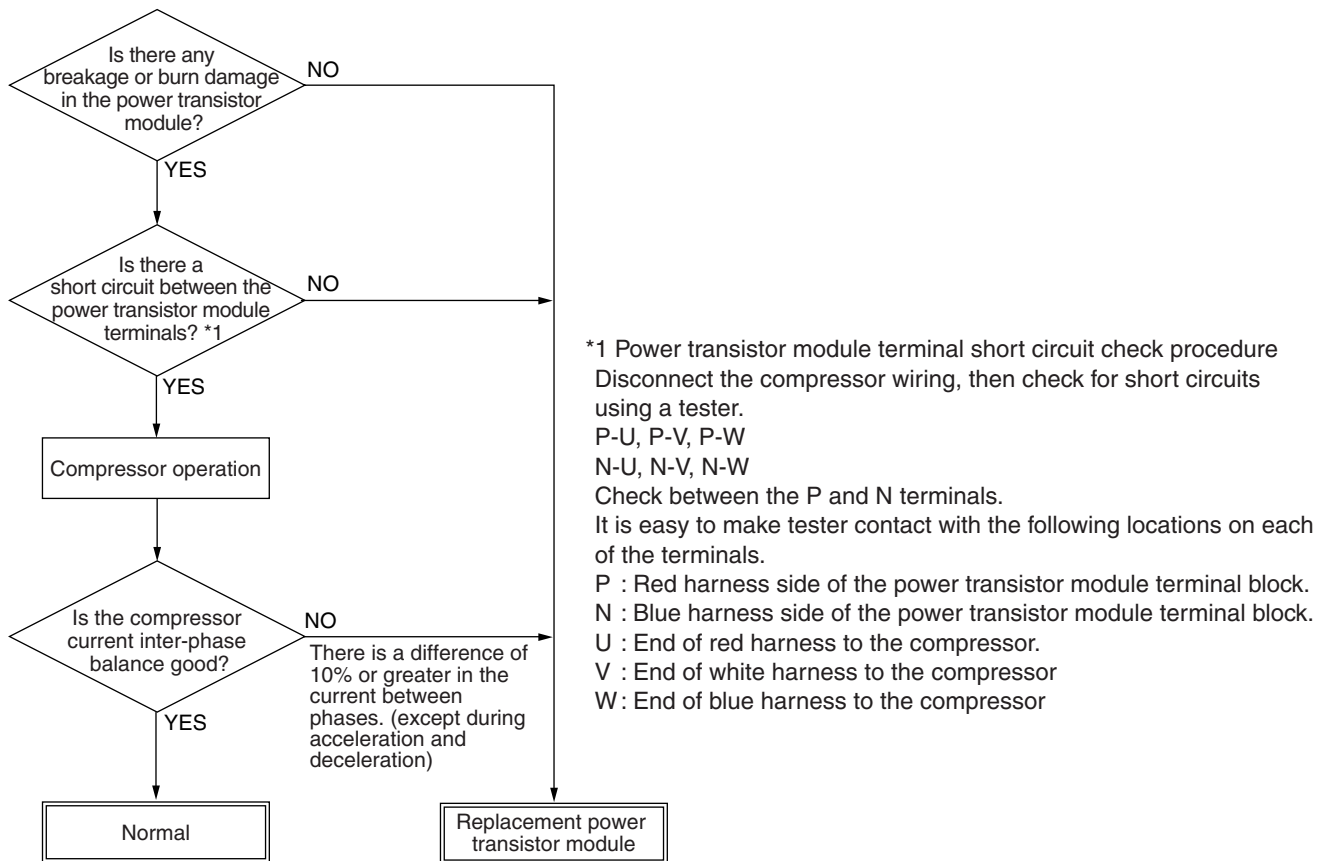

### ■ Check points

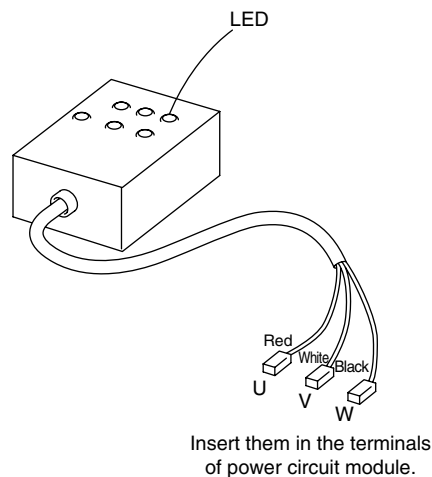

#### 1. Set procedure of the checker

- ① The power supply is turned off. (breaker OFF)
  - ② Disconnect the wiring of compressor is removed from the output U, V, and W (power circuit module) of inverter PCB.
  - ③ Connect the wiring of the checker (U = red, V = white, W = black) to the terminals of power circuit module.
- Note (1) When the checker is used in the field side, connected wiring for the relay is necessary, because the terminals of power circuit module of the FDCA224~680 types is of round shape.

2. Method for judging operating condition

a) Operate it with the test run switch on the outdoor control board.

SW5-1	ON	SW5-2	OFF	test run for heating
			ON	test run for cooling
	OFF	Normal and the test run ends		

b) Make sure the flashing status of 6 LEDs

c) Judges according to the flashing status of LED

Flashing status of LED	6 LEDs flash simultaneously	6 LEDs turn off or several LEDs flash
Inverter	Normal	Defect

d) Operation must end in about five minutes.

FDCA140 Type

Inverter board

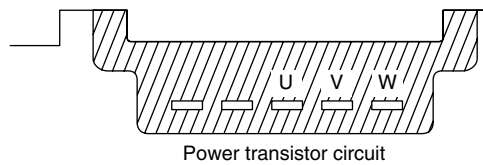

FDCA224 ~ 680 Type

Inverter board

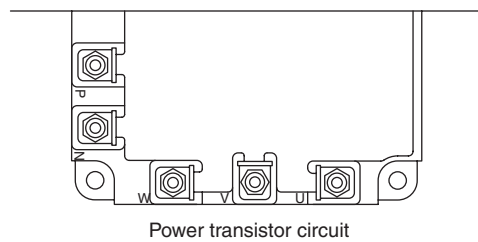

## 2.5 Inspection Method When There Is No Error Display

### Louver motor does not operate

- Inspect at the indoor unit side.

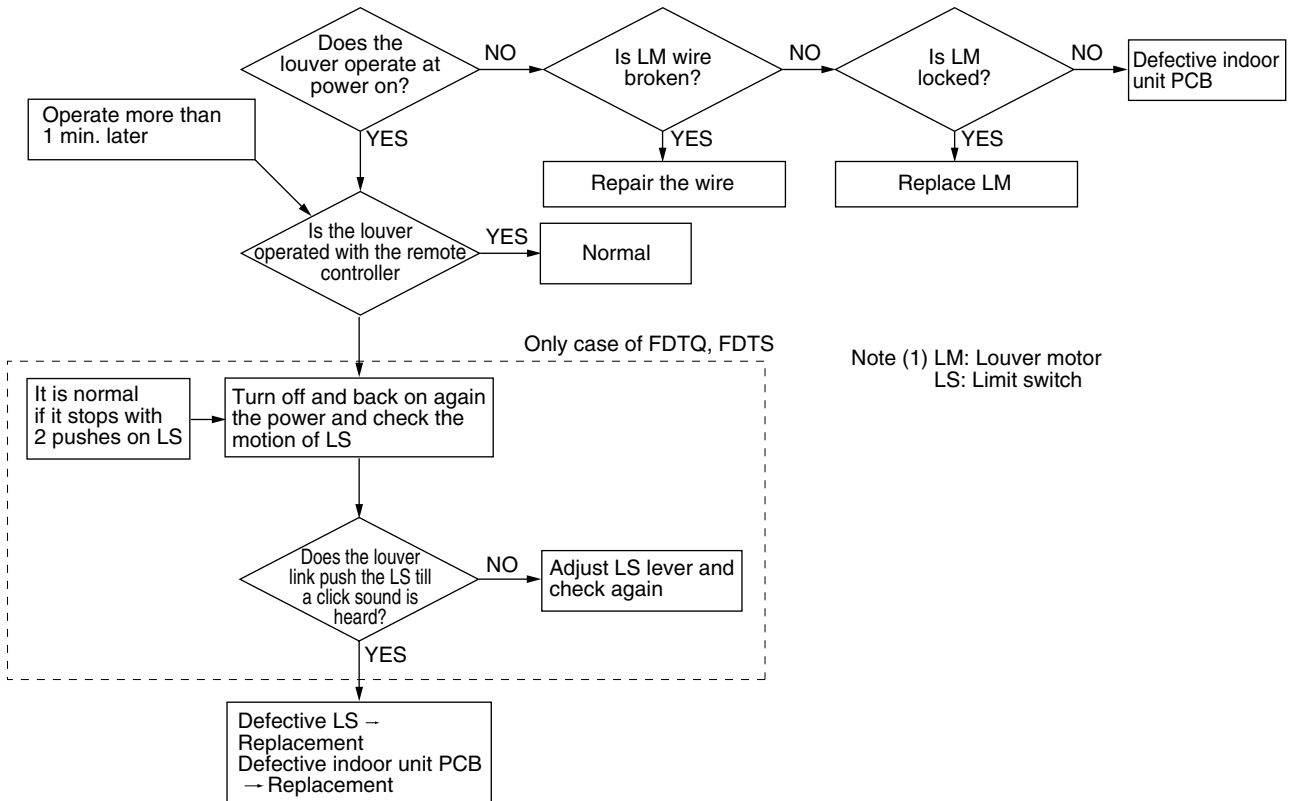

### When the indoor unit blower does not operate

- Inspect at the indoor unit side.

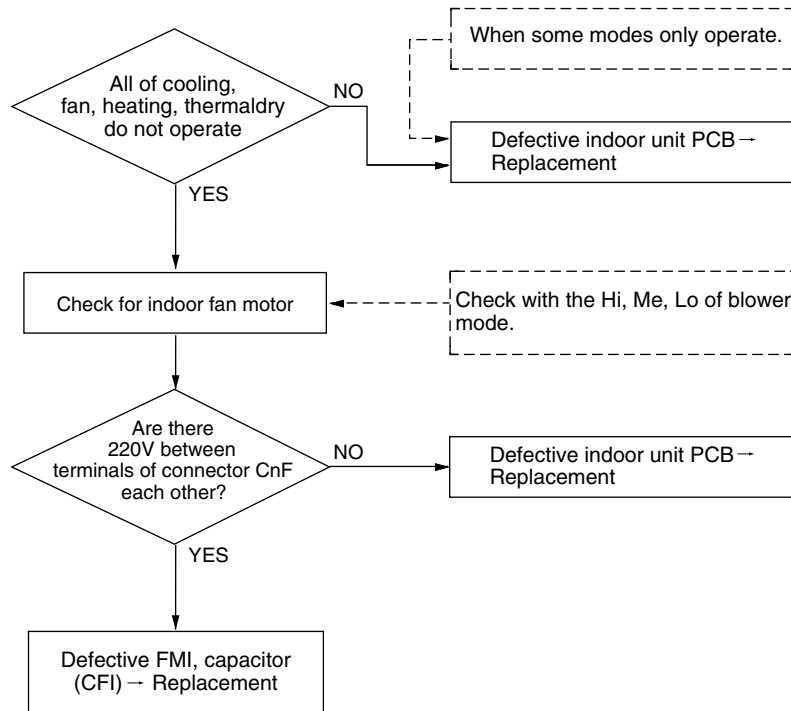



**Four way valve does not switch during heating operation**

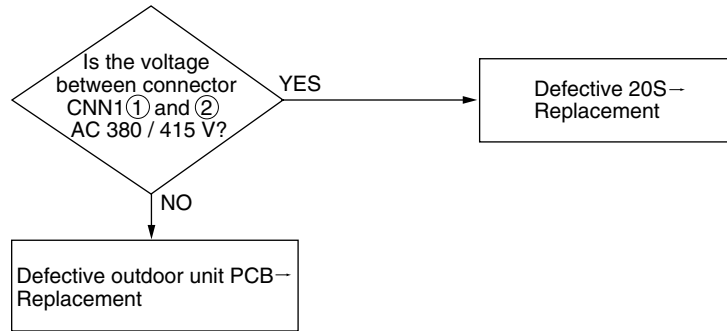

**Check method for operation of the indoor electronic expansion valve of indoor unit**

Make sure the indoor unit controller → the output of expansion valve according to the following points.

- ① It is determined by measurement that how much V is in the pin on the controller side of expansion valve (SM) connector · CnA (white 6P (five cores)) and how many seconds the voltage is applied.

White	~ Brown	}	There is about DC5V <sup>(2)</sup> for around 15 <sup>(1)</sup> seconds when the power supply is turned on.
Yellow	~ Brown		
Orange	~ Brown		
Blue	~ Brown		

- ② If the voltage above-mentioned for around (5 seconds) can be made sure, the indoor unit controller is normal. If the expansion valve doesn't operate under some condition (The operation sound is not heard), the expansion valve is defective.
- ③ The expansion valve begins to operate at about 20 seconds if the thermostat setting is changed. The DC voltage of about 5V can be made sure with CnA as well as the above-mentioned.

Notes (1) It becomes about 5V for eight seconds after the power supply is turned on, it falls momentarily, and it becomes about 5V for about seven seconds.

(2) The voltage of about 6~3V is output in turn if measured it with digital multi tester.

## 2.6 Functions of the Control Circuit Board of the Outdoor Unit

### 2.6.1 Control cabinet of the outdoor unit KX4 series (5 - 12 HP)

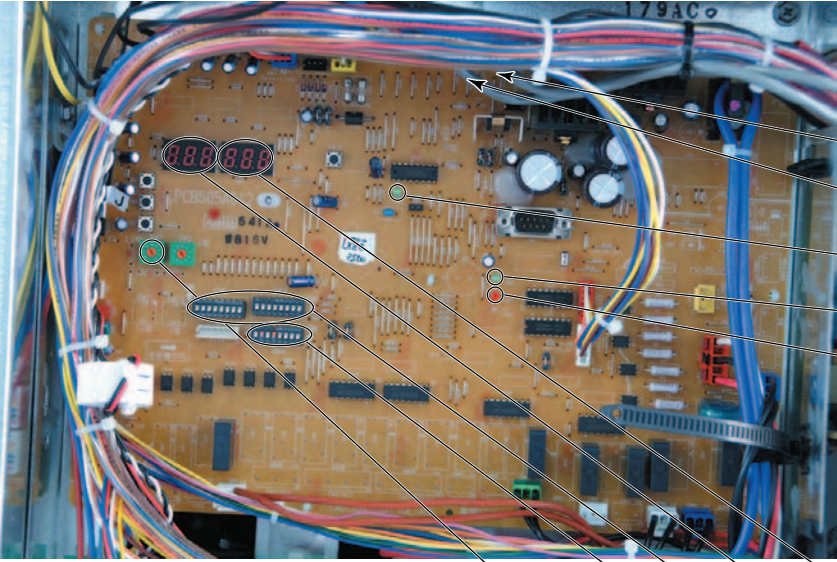
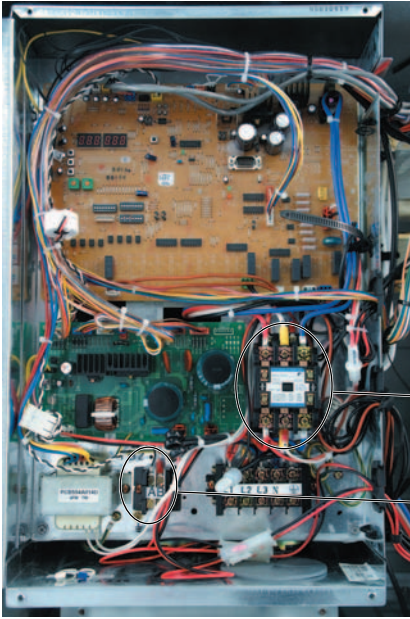
<p>Control cabinet of the outdoor unit KX4 series (5 - 12 HP)</p>	<p>Model: FDCA335HKXE4</p>
	<p>Unit number:</p> <p>Picture No. 1</p> <p>Description: Outdoor unit control cabinet</p> <p>Special notes:</p> <ul style="list-style-type: none"> <li>External operation</li> <li>Forced cooling and heating</li> <li>Repair</li> <li>Normal</li> <li>Service indicator</li> <li>7-Segment display (Data display)</li> <li>7-Segment display (Fuction)</li> <li>Fuction Switching button</li> <li>S4 Fuction Switching button:                     <ul style="list-style-type: none"> <li>1 ~ 4: Model selection</li> <li>5 ~ 6: Requirement selection</li> </ul> </li> <li>Address setting</li> </ul>
	<p>Picture No. 2</p> <p>Description: CM Magnetic contactor &amp; Signal terminal A / B</p> <p>Special notes:</p> <p>Round end sleeves should be used to mount the ends of the signal wires.</p> <ul style="list-style-type: none"> <li>CM Magnetic contactor</li> <li>A / B Signal terminal block</li> </ul>

### 2.6.2 Control cabinet of the outdoor unit KX4 series (12 - 24 HP)

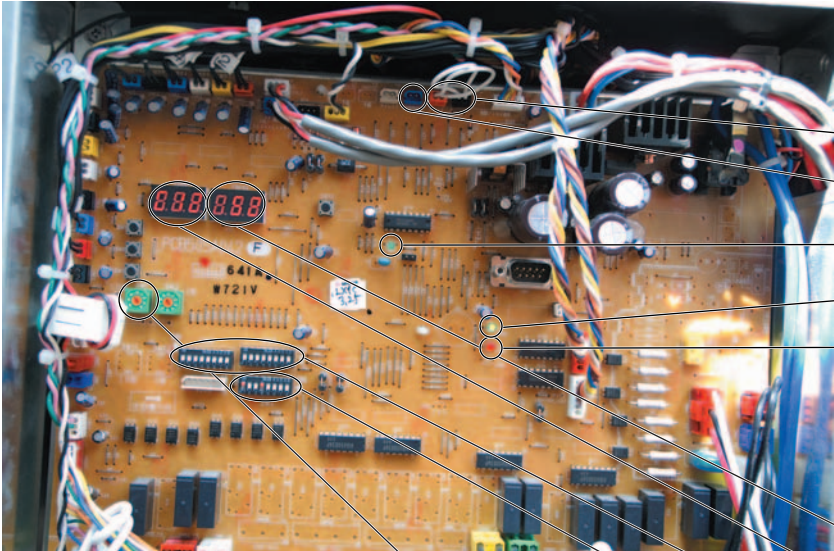
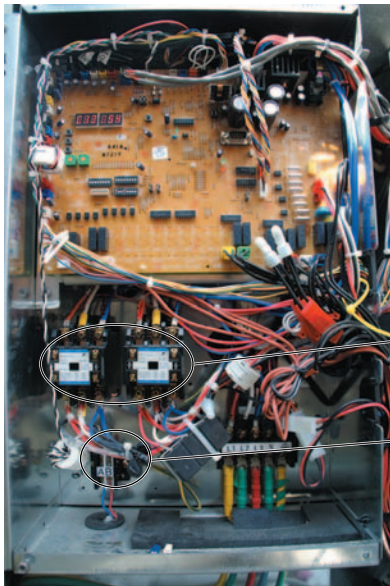
<p>Control cabinet of the outdoor unit KX4 series (12 - 24 HP)</p>	<p>Model: FDCA335HKXE4-K</p>
	<p>Unit number:</p>
	<p>Picture No. 1</p> <p>Description: Outdoor unit control cabinet</p> <p>Special notes:</p> <ul style="list-style-type: none"> <li>External operation</li> <li>Forced cooling and heating</li> <li>Repair</li> <li>Service indicator</li> <li>Service indicator</li> <li>7-Segment display (Data)</li> <li>7-Segment display (Function)</li> <li>Function switching button</li> <li>S4 Function switching button</li> <li>1 ~ 4: Model setting</li> <li>5: Demand selection</li> <li>6: Demand selection</li> <li>7: Address setting switch (Main-Sub)</li> <li>8: Address setting switch (Main-Sub)</li> <li>Address setting</li> </ul>
	<p>Picture No. 2</p> <p>Description: CM Magnetic contactor &amp; Signal terminal A / B</p> <p>Special notes:</p> <p>Round end sleeves should be used to mount the ends of the signal wires.</p> <ul style="list-style-type: none"> <li>CM Magnetic contactor</li> <li>A / B Signal terminal block</li> </ul>

# Part 7 Appendix

<b>1. Safety Solutions for Refrigerant Leakage .....</b>	<b>688</b>
1.1 Confirmation Procedure for Critical Concentration and Refrigerant Concentration .....	688
1.2 Counter Measures for Exceeding the Critical Concentration (JRA-GL 13-1998) .....	689
1.3 Flowchart of Countermeasures Against Refrigerant Leakage .....	692

# 1. Safety Solutions for Refrigerant Leakage

When an air-conditioner is installed in the room, it should be ensured that the critical concentration of the indoor refrigerant gas won't be exceeded in case of refrigerant leakage.

R410A is used by the air-conditioner. Although the refrigerant itself is non-toxic, incombustible and safe, the size of the room with the air-conditioner installed still needs to be taken into account and proper practices are required to ensure that the critical concentration of the indoor refrigerant gas won't be exceeded in case of refrigerant leakage.

## 1.1 Confirmation Procedure for Critical Concentration and Refrigerant Concentration

### a) Critical concentration

The critical concentration refers to the limit of the freon concentration that can be handled through emergency actions without doing any harm to human beings in case of refrigerant leakages.

For easy calculation, the critical concentration is in a unit of  $\text{kg}/\text{m}^3$  (the weight  $\text{kg}$  of Freon in  $1\text{m}^3$  of air.)

The critical concentration of R410A is  $0.3\text{kg} / \text{m}^3$   
 (The standard applicable for KHK facilities is S0010)

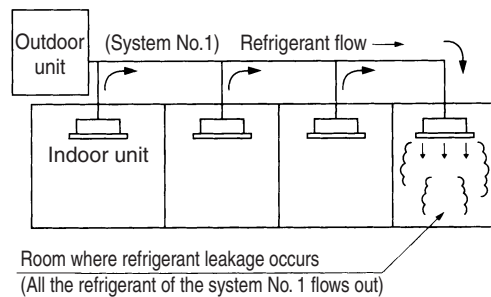

### b) Refrigerant concentration

Please calculate the refrigerant concentration following Step ① to ③.

① Calculate the total amount of refrigerant charged into each refrigerant system. (kg)

[Calculation method]

(Refrigerant charging for 1 outdoor unit system) + (Additional refrigerant charging) = Total amount of refrigerant charged in the equipment (kg)

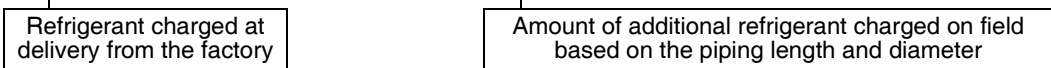

Note (1) : If there exist more than 2 refrigerant systems in 1 refrigerant equipment and these systems are independent from each other, use the respective refrigerant charging amount.

② Calculate the smallest room cubage ( $\text{m}^3$ )

In the following cases, please use  part as one room or take the smallest room as the calculation unit to calculate the room cubage.

(i) Locations without inner walls

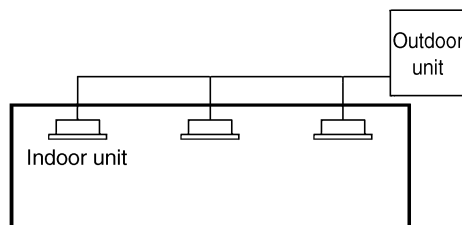

(ii) Locations having inner walls but also having openings through which effective ventilation is possible with the adjacent rooms

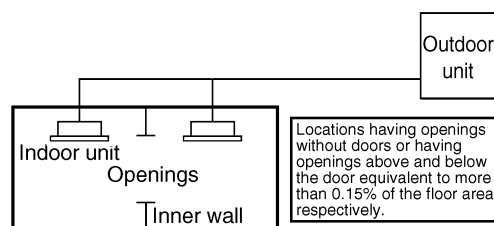

(iii) Locations having inner walls but no effective openings

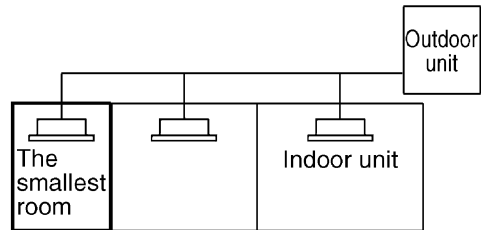

③ Calculate the refrigerant concentration based on results obtained through Step ① and ②.

[Calculation method]

$$\frac{\text{Total refrigerant charging amount for the refrigerant equipment (kg)}}{\text{Cubage of the smallest room where a machine containing refrigerant is installed (m}^3\text{)}} = \text{Refrigerant concentration (kg/m}^3\text{)}$$

In case the critical concentration of the refrigerant is exceeded, please transfer the refrigerant in turns to rooms with bigger cubage and perform the same calculation. Please determine all objects with concentration exceeding the critical one.

## 1.2 Counter Measures for Exceeding the Critical Concentration (JRA-GL 13-1998)

Please take appropriate measures corresponding to the room cubage according to the following instructions when the critical concentration of the refrigerant is exceeded.

### Method 1: Set up effective ventilation openings.

- Please leave openings equivalent to more than 0.15% of the floor area respectively above and below the door connecting the outside room or set up openings without doors.

### Method 2: Reduce the total amount of refrigerant charged into the refrigerant equipment.

- Shorten the refrigerant piping.  
Locate the outdoor unit closer to the indoor unit to shorten the refrigerant piping and reduce the total refrigerant charging amount.
- Decrease the outdoor unit capacity.  
Divide the outdoor unit into multiple units to reduce the outdoor unit capacity for one refrigerant system and reduce the refrigerant charging amount.

For example, if divide one 20HP system into two 10HP systems, the refrigerant amount for one refrigerant system will be cut by half approximately.

### Method 3: Set up a ventilation system (See the flowchart in Page 649).

By setting up a ventilation system, excessively high refrigerant concentration can be prevented in case of refrigerant leakages. The ventilation system may work through the introduction of outside air or exhaust. Considering the nature of the refrigerant used, the introduction of outside air is recommended.

- Ventilation volume  
Please take into consideration the total refrigerant charging amount of the refrigerant equipment objects and the room cubage and make sure that the ventilation volume is higher than that shown in Figure 4 (in the next page).
- Sensor and linkage  
In principle, the ventilation system should work normally no matter whether an air-conditioner is installed or whether a human is in the room.  
If long-term operation cannot be realized, please use a sensor system to ensure that the ventilation system can run automatically in case of refrigerant leakage.  
Figure 1 (on the next page) shows a ventilation system applicable to long-term operation. Figure 2 (on the next page) shows a sensor linkage system.

- Notes (1) Even if a ventilation system is set up, the range indicated as oblique lines in Figure 4 should not be selected to prevent failures of the ventilation system. If the range is entered, Method 1 and 2 mentioned above should be followed in principle to cut the total refrigerant amount, i.e. to set up effective ventilation openings, increase the room cubage, reduce the outdoor group capacity or change the piping length.
- (2) When the ventilation system is installed, measures independent from the ventilation system should be adopted for the sake of safety in case the range indicated as oblique lines in Figure 4 is entered at locations impossible to use Method 1 and 2. To be specific, a refrigerant shutoff valve working via the sensor in case of refrigerant leakage and an alarm system informing the indoor personnel should be set up at the same time. The sensors involved here are different from those in the ventilation system described above. Figure 3 (on the next page) shows the situation of the refrigerant shutoff valve set.
- (3) When a ventilation system is set up, effective ventilation gaps (e.g. gaps below the doors) must be retained at the lowest position of the room.

- (4) Special attentions should be paid to piping connections inside residential areas. The constructions should be performed in strict accordance with JIS specifications and a complete air-tightness test should be performed after the constructions are completed. In addition, anti-seismic measures should be made available during the piping installation to avoid damages by external forces such as earthquake. (Sufficient space should be preserved along the axial direction to prevent stresses arising from temperature changes.)

Long-term ventilation system (Figure 1)

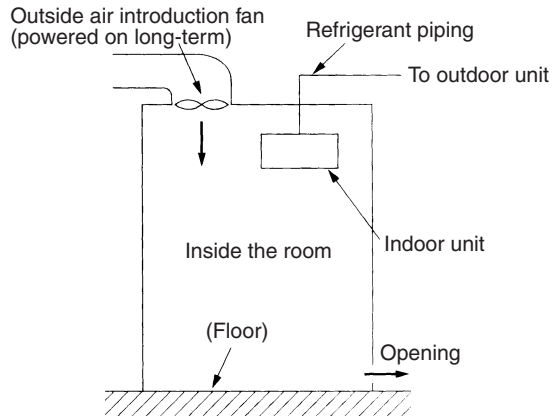

Sensor linkage system (Figure 2)

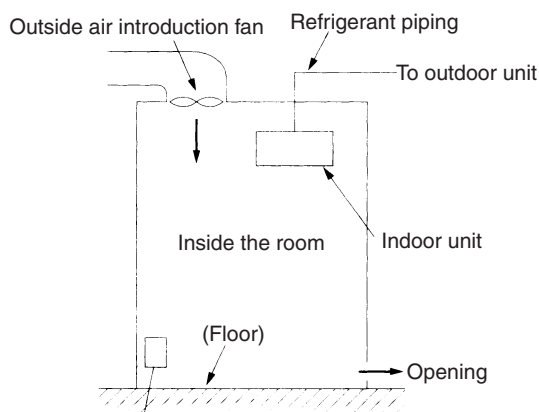

The refrigerant leakage detection sensor (oxygen sensor, refrigerant detector) is installed less than 0.3m above the floor, a position where refrigerant tends to stagnate.

Installation of long-term ventilation system and refrigerant shutoff valve (Figure 3)

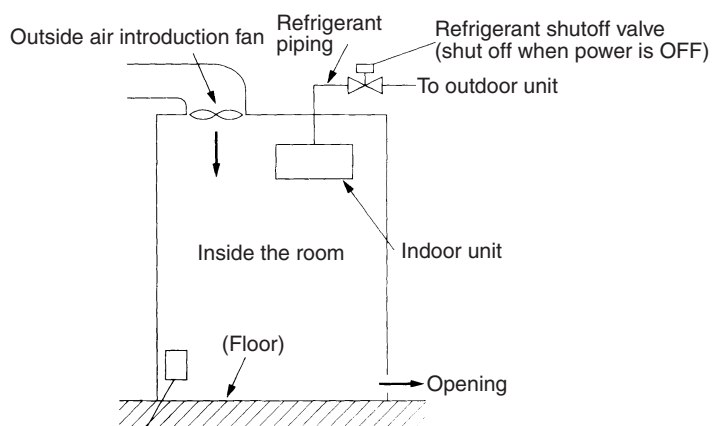

The refrigerant leakage detection sensor (oxygen sensor, refrigerant detector) is installed less than 0.3m above the floor, a position where refrigerant tends to stagnate.

System selection based on ventilation volume (Figure 4)

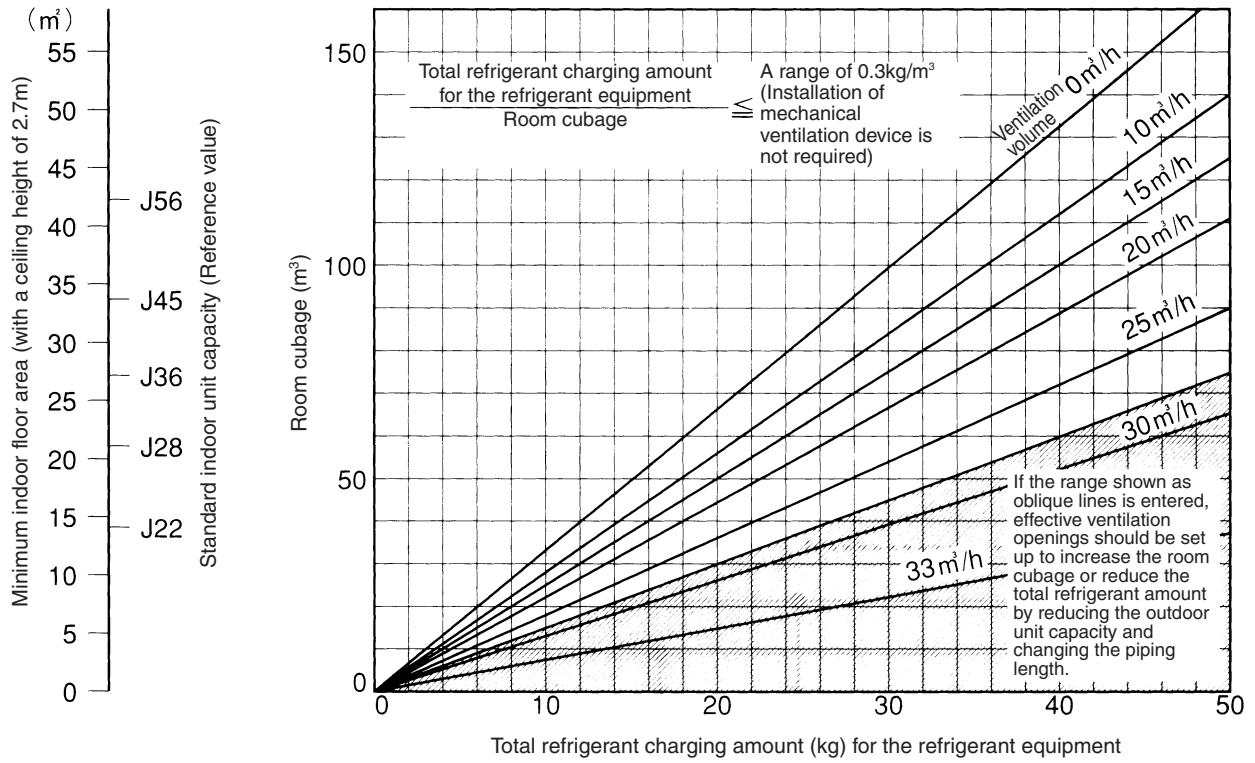



### 1.3 Flowchart of Countermeasures Against Refrigerant Leakage

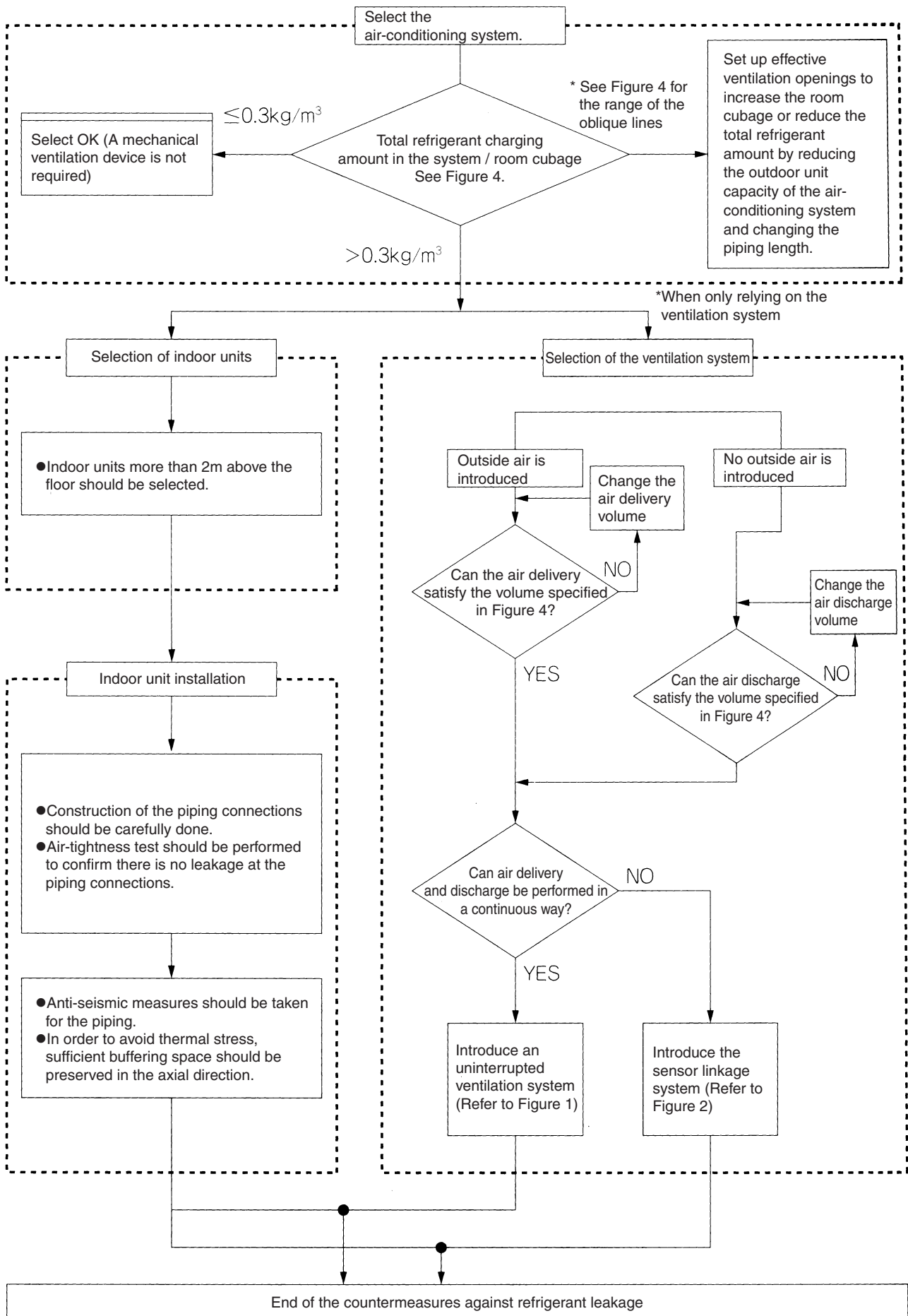

**Check on use limitations related with equipment designs.**

- The check is chiefly done by listening and investigation of actual conditions, and the correction treatment is proposed to the trader.

No.	Item	Reference	Result	Content of treatments	Treatment date
1	The number in which indoor unit can be connected	① Refer to following note (1)		Indoor unit addition or separation	
2	Capacity in which indoor unit can be connected	① Refer to following note (1)		Indoor unit addition or separation	
3	Is the driving always under the state of the capacities unbalancing between indoor unit and outdoor unit	① It is not preferable that a small capacity indoor unit alone is operating for a long time with respect to a large capacity outdoor unit.			
4	Limitation on refrigerant piping length	① Main pipe $\leq 70\text{m}$ ② Branch pipe (The first branch to Indoor unit) $\leq 30\text{m}$		Corrections within the use limitation.	
5	Height difference between indoor unit and outdoor unit	① The outdoor unit is the above : $\leq 30\text{m}$ ② The outdoor unit is the below : $\leq 15\text{m}$		Same as above	
6	Height difference between indoor units	① $\leq 4\text{m}$		Same as above	
7	Installation space (indoor / outdoor units)	① Refer to technological material.			

Note (1) Number in which indoor unit can be connected (When the number exceeds, abnormally stop [E43].)

The number in which indoor unit can be connected (unit)	1 ~ 8	1 ~ 6
Capacity in which indoor unit can be connected (%)	80 ~ 130	80 ~ 150

(2) The correction of the above-mentioned all items is proposed to the construction contractors.

## KX4 Equipment Design Check Sheet

Model: \_\_\_\_\_

No. \_\_\_\_\_

User: \_\_\_\_\_

Sequence number	Classification	Items to be checked	Standard	Result	Processing result	Date of enforcement
1	System	Load calculation and model selection	Is the load calculation made under both cooling and heating conditions?	Models matching with higher load must be selected		
2			Is the selection of the air-conditioner based on the various corrected capacities?	<ul style="list-style-type: none"> <li>① Corrections based on the refrigerant piping length</li> <li>② Corrections based on the height difference between the indoor unit and the outdoor unit</li> <li>③ Corrections based on the design room temperature</li> <li>④ Corrections based on the design ambient air temperature</li> <li>⑤ Corrections based on the connecting capacity (100% &lt;) of the indoor unit</li> </ul>		
3			Are the following factors considered for the combination of the indoor / outdoor units: ① Balance of the connecting capacity of the indoor units ② Balance of the operating ratio and the simultaneous load rate of the outdoor units ③ Balance between cooling and heating	<ul style="list-style-type: none"> <li>• The capacity of the outdoor unit is MAX</li> <li>• The sunlight load and the internal heat generation must be considered</li> </ul>		
4			Is the number and capacity of the connected indoor units within the limit?	<ul style="list-style-type: none"> <li>• Problems may arise if the limits are exceeded</li> </ul>		
5	Indoor		Are there a few small indoor units running 24 hours consecutively?	<ul style="list-style-type: none"> <li>• If possible, separate the indoor unit from KX4</li> </ul>		
6			Is the allowable indoor noise level considered for the selected model?	<ul style="list-style-type: none"> <li>• Be careful with the units installed in hotels, living rooms, bedrooms and reception rooms</li> </ul>		
7	System	Piping distance and installation space	Is the length of the refrigerant piping within the specified limit?	<ul style="list-style-type: none"> <li>• Problems may arise if the limits are exceeded</li> </ul>		
8			Is the height difference between the indoor unit and the outdoor unit within the specified limit?	<ul style="list-style-type: none"> <li>• Confirmation is a must</li> <li>• Problems may arise if the limits are exceeded</li> </ul>		
9			Is the height difference between the indoor units unit within the specified limit?	<ul style="list-style-type: none"> <li>• Within 15m</li> </ul>		
10			Does the dimension of the refrigerant piping depend on the capacity of the indoor unit?	<ul style="list-style-type: none"> <li>• Confirmation is a must</li> </ul>		
11	Indoor		Is the installation space for indoor units within the specified limit?	<ul style="list-style-type: none"> <li>• Problems may arise if the limits are exceeded</li> </ul>		
12	Outdoor		Is the installation space for outdoor units within the specified limit?	<ul style="list-style-type: none"> <li>• Problems may arise if the limits are exceeded</li> </ul>		
13			Is the installation position for the combination inverter unit qualified?	<ul style="list-style-type: none"> <li>• The inverter unit must be located at the first branch manifold closest to the indoor unit</li> </ul>		
14	Outdoor	Electric Equipment	Are different power sources used for the indoor and outdoor units?	<ul style="list-style-type: none"> <li>• Different power sources should be used</li> </ul>		
15			Are different power sources used for the main unit and each sub unit in the combination KX4?	<ul style="list-style-type: none"> <li>• Different power sources should be used for different units</li> </ul>		
16			Is the current leakage breaker firmly set up?	<ul style="list-style-type: none"> <li>• Separate setting is required</li> </ul>		
17			Does the current leakage breaker of the outdoor unit (the unit carrying the inverter compressor) match the inverter type?	<ul style="list-style-type: none"> <li>• Circuit breakers corresponding to the inverter type must be used</li> </ul>		

Installer : \_\_\_\_\_

Inspector : \_\_\_\_\_

Date of installation : \_\_\_\_\_

Date of inspection : \_\_\_\_\_

**Check related with construction**

- The check is chiefly done, and then the correction is proposed to the trader .

No.	Item	Reference	Result	Content of treatments <sup>(1)</sup>	Treatment date
1	Capacity of breaker for power supply	① Capacity described in material (excessive to improper protection) ② With the leak breaker (INV unit corresponding to INV)		Correct according to left mentioned.	
2	Local wiring terminal processing	① Use terminals for the connection to the terminal block.		Correct according to left mentioned.	
3	Parallel wiring of signal wire and strong electric wire	① Separate when longer than 0.5m (The binding of a strong signal / electric wire is improper if longer than 10m). ② Using coaxial cable for signal / strong electric wires is improper.		Correct according to left mentioned.	
4	Is there mixed use of signal wire and strong electric wire?	① Resistance between terminals A and B ( $\Omega$ ) $\approx$ $9100\Omega \div$ (number of indoor units and outdoor units and SLA)		Correct before turning on power.	
5	Material of refrigerant pipe	① Is the size proper? (Refer to material) ② Is the branch pipe used pure and installing method		Correct according to left mentioned.	
6	Was the airtight test done?	① Specified pressure : R22 = 2.94MPa R407C = 3.23MPa		Correct according to left mentioned.	
7	Vacuum drawing	① Has vacuum been drawn in 60 minutes after pressure reaches to 750Mhg?		Correct according to left mentioned.	
8	Refrigerant enclosing	① This machine meets the Chargeless specification and the additional enclosing of refrigerant portion for local piping is unnecessary.		Correct according to left mentioned when not treating.	
9	Address (indoor / outdoor units)	① Confirmation on the equipment drawing. ② Have the addresses of outdoor and the sub unit been set?			
10	Drain check of indoor unit	① Was drain check done?		Notice at test run when trying when not treating	

Remark : Correction is requested to the construction contractor and confirm later.

### KX4 Construction Check Sheet

Model : \_\_\_\_\_

No. \_\_\_\_\_

User : \_\_\_\_\_

Sequence number	Classification	Items to be checked	Standard	Result	Processing result	Date of enforcement
1	Indoor / Outdoor	Is the installation space for indoor and outdoor units within the specified limit? <ul style="list-style-type: none"> <li>• Ventilation space</li> <li>• Indoor unit: dimension above the ceiling</li> </ul>	① Check whether the outdoor unit has any index of air circulation short circuit; the difference between the ambient air temperature and the air suction temperature of the outdoor unit must not exceed 3deg. ② Indoor unit: are the air reaching distance limit, the air circulation short circuit limit and the upper dimension of the ceiling appropriate?			
2		Has the base of outdoor units been processed? Have any base bolts been installed? <ul style="list-style-type: none"> <li>• Have any anti-tipping methods been discussed?</li> <li>• Is the drainage of condensed water and rain water being obstructed?</li> </ul>	<ul style="list-style-type: none"> <li>• A structure that enables the smooth drainage of rain water and condensed water is required to be available.</li> </ul>			
3	Indoor	Installation Is the installation position for the indoor unit (the position of the suspension bolts) consistent with the position of the holes drilled on the ceiling?  Is the size of the suspension bolts used the same as specified?  Have any protection measures been taken to the indoor units to prevent possible damage from the construction welding material splashes?  Is the air condition inside the ceiling within the specified limit?	① The positions must be consistent.			
4			• Confirmation is a must.			
5			① The unit must not be unpacked until the installation starts. ② The corrugated boards included must be used as a protection measure after the unit is installed.			
6	Outdoor	Are the combination air-conditioner and the main unit installed at the first branch manifold closest to the indoor unit?	• 28°CDB, relative humidity below 80%			
7			① The main unit must be located at the first branch manifold closest to the indoor unit.			
8	System	Is the length of the refrigerant piping within the specified limit?  Is the height difference between the indoor unit and the outdoor unit within the specified limit?  Are different power sources used for the indoor and outdoor units?	• Confirmation is a must.			
9			• Confirmation is a must.			
10			• Different power sources should be used.			
11	Outdoor	Power source Are different power sources used for the main unit and each sub unit in the combination KX4?  Is the voltage of the power source within the specified limit?  Do the specifications of the wiring and circuit breaker comply with laws and regulations of relevant country?  Is the current leakage breaker firmly set up?	• The power source must not be connected from the main unit to the sub unit (the wiring size is required to be less than 22mm <sup>2</sup> ).			
12			<ul style="list-style-type: none"> <li>• Voltage fluctuation in operation: within ± 10%</li> <li>• Voltage drop at the compressor start-up: within -15%</li> <li>• Imbalance among phases: within ± 3%</li> </ul>			
13						
14			• Current leakage breakers should be properly set up for each unit.			
15	Indoor / Outdoor	Signal wire Does the inside / outside signal wire have loop wiring?  Are the signal wire and the power cord crossed?  Are the inside/outside signal wire and the shared line crossed?  Is the signal wire of the correct type and size?	• Loop wiring is not permitted.			
16			• The type of wire must be changed.			
17			• The type of wire must be changed.			
18			<ul style="list-style-type: none"> <li>• Size: 0.75 ~ 2.0mm<sup>2</sup></li> <li>• Type: VCTF, VCT, CVV, MVVS</li> </ul>			

Sequence number	Classification	Items to be checked	Standard	Result	Processing result	Date of enforcement
19	System	Are the materials of refrigerant piping qualified?	• Phosphor deoxidised seamless tube			
20		Do the dimensions of the refrigerant piping depend on the capacity of the indoor unit?	• Dimensions: based on the capacity of the indoor units			
21		Water return pipes must not be installed in the middle of refrigerant piping.	• Do not install water return pipes.			
22		Is nitrogen used in welding?	• Charge nitrogen at the same time or after the nitrogen replacement is finished.			
23		Are proper protection measures taken in the course of the construction, such as sealing the pipe ends and preventing ingress of rainwater and dust?	• Seals that are not easily damageable must be provided (every day during the suspension of the construction). • Protection measures must be taken to prevent the ingress of foreign substances into the piping during temporary storage.			
24		Do the branch pipes use qualified products?	• The product number of the genuine products must be confirmed.			
25		Are the branch pipes properly set?	• Horizontal or vertical set-up is a must.			
26		Are suspension bolts (anti-vibration) used to support the piping?	• To be set every 2m.			
27		Are anti-vibration and heat insulation measures taken for the refrigerant piping at locations running through walls, girders, etc.?				
28		Outdoor	Combination KX4: are the oil equalizing pipes between the main units and the sub units properly connected?	• To be properly connected.		
29	Indoor / Outdoor	Have the liquid pipes and gas pipes in the refrigerant piping been given heat insulation treatment?	• Materials with a thermal endurance of 120°C or more must be used. • Materials that are not subject to dew condensation when the surface temperature of the piping is 0 to 5°C must be used.			
30	Indoor	Is seamless construction performed at the joints of the thermal insulator (the joints of thermal insulators between the piping and the air-conditioner)?	• The joints (joints of the heat insulators in the middle of the piping as well as the joints between the piping and the indoor unit (flare nuts)) must be tightly sealed. • Tapes used to fix the insulators must not be wrapped too tight to keep the heat insulator undamaged.			
31	Drain piping	Does the drain piping incline downward during the construction?	• Appropriate gradient = 1/50 - 1/100			
32		Are "water return pipes" installed in the drain piping?	• No water return pipe should be installed in units having an exterior static pressure of 0Pa.			
33		Is the main drain pipe connected to the top of the main pipe?				
34		Does the drain piping of the units using drain pumps (built-in or optional) have a suitable vertical height?	• 600 - 750mm(calculated from under the ceiling or the unit)			
35		Are the attached standard drain hoses used in the units using the drain pump?	• Standard hoses must be used.			
36		Are the attached straps used for fixing the typically supplied hoses?	• No adhesives are permitted.			
37		Is the site drain piping of the units using drain pumps adjacent to the units?	• Between 295 and 325mm.			
38		Does the drain piping absorb any peculiar smell?				
39		Has the drain piping been given heat insulation treatment?	• Approx.5°C condensed water flows			
40		Is the piping properly supported?	• To be set every 1~2m (PVC pipe: every 1m, steel pipe: every 2m)			

Sequence number	Classification	Items to be checked	Standard	Result	Processing result	Date of enforcement	
41	System	Air-tightness test	Has an air-tightness test been performed?	<ul style="list-style-type: none"> <li>Pressure: R22=2.94MPa, R407C=3.23MPa</li> <li>Gas used: nitrogen</li> <li>Standard: the pressure must keep constant for 24 hours. (Temperature correction = ±approx. 0.01MPa / 1°C)</li> </ul>			
42		Vacuuming & refrigerant enclosure	Is the vacuuming sufficient?	<ul style="list-style-type: none"> <li>A 60-minute vacuuming must be performed when the vacuum degree reaches 750mmHg.</li> <li>The vacuuming must be performed from both the liquid pipe and the gas pipe.</li> </ul>			
43			Is the refrigerant amount for the site piping calculated?	<ul style="list-style-type: none"> <li>The part of the liquid pipe should be taken as reference for the additional enclosure.</li> </ul>			
44			Has a measured refrigerant enclosure been performed? <ul style="list-style-type: none"> <li>Electric current or operation pressure must not be used as the indicator for the refrigerant enclosure.</li> </ul>	<ul style="list-style-type: none"> <li>Refrigerant enclosure must be performed properly according to the value calculated using a metering cylinder or scale.</li> <li>After the vacuuming is finished, the refrigerant should be enclosed from both the gas pipe and the liquid pipe at the same time with the operation valve closed.</li> <li>Refrigerant that cannot be enclosed should be enclosed during the operation of the air-conditioner. In addition, gaseous refrigerant must be enclosed at the low pressure check joint in front of the pressure accumulator.</li> </ul>			
45			Does the nameplate of the outdoor unit have information about the calculated value and enclosing amount of the refrigerant?	<ul style="list-style-type: none"> <li>Piping size, length and enclosure amount must be recorded.</li> </ul>			
46			What is the mass of the refrigerant (moisture content)?	<ul style="list-style-type: none"> <li>The standard value is 80ppm.</li> </ul>			
47		Address	Are proper address numbers determined?	<ul style="list-style-type: none"> <li>Has reasonable determination be made (similarity between the operation time belts) after giving consideration to the combination of indoor unit / outdoor unit, purpose of the room, time of use and sorting of occupants?</li> </ul>			
48			Are the address numbers of the indoor/outdoor units clearly indicated on the equipment diagram (indoor unit configuration diagram, etc.)?				
49			Have the drawings been submitted to the address setting operator, and setting instruction been given?	<ul style="list-style-type: none"> <li>Instructions must be made via the drawings instead of verbal indication.</li> <li>Standards for selection of address setting methods                             <ol style="list-style-type: none"> <li>Signal wire, individual: automatic address or manual address</li> <li>Signal wire, super link, manual address</li> </ol> </li> </ul>			
50			Has any confirmation been made on whether there is any crossing of the signal wire and the power cord?	<ul style="list-style-type: none"> <li>The resistance should be measured at the terminal block (A, B) of the signal wire and the measured value should be close to the one calculated with the following formula. Appropriate resistance value (Ω) = 9100 / number of connected units. If the actually measured resistance is below 80Ω, there definitely exist some crossed wires.</li> </ul>			

Installer : \_\_\_\_\_

Inspector : \_\_\_\_\_

Date of installation : \_\_\_\_\_

Date of inspection : \_\_\_\_\_

## KX4 Test Run Check Sheet

Model : \_\_\_\_\_

No. \_\_\_\_\_

User : \_\_\_\_\_

	Items to be checked	Standard	Result	Processing result	Date of enforcement
1	Has any confirmation been made on whether there is any crossing of the signal wire and the power cord?	<ul style="list-style-type: none"> <li>• The resistance should be measured at the terminal block (A, B) of the signal wire and the measured value should be close to the one calculated with the following formula.</li> <li>* Appropriate resistance value (<math>\Omega</math>) = <math>9100 / \text{Number of connected units}</math></li> <li>* If the measured resistance is below <math>80\Omega</math>, crossed wires can be confirmed.</li> </ul>			
2	Has any confirmation been made of the correct combination of indoor / outdoor units (address or refrigerant piping) (as shown in the drawing)?	<ul style="list-style-type: none"> <li>• The units must be operated and confirmation must be performed based on the air heat exchange temperature of the indoor unit.</li> </ul>			
3	Confirm that the system is free of defects based on the operation data.	Refer to the instructions on the test run.			
4	Has a drainage test been performed for the condensed water?				

Installer : \_\_\_\_\_

Inspector : \_\_\_\_\_

Date of installation : \_\_\_\_\_

Date of inspection : \_\_\_\_\_



# MEMO

## Symbols

<Space Calculation> .....	28
"Check on construction" by servicemen .....	598
"Super Link Network" Control System .....	484

## Numerics

1-way Outlet Ceiling Recessed Type (FDTSA) Specifications .....	160
2-way Outlet Ceiling Recessed Type (FDTWA) Specifications .....	139
3 laws necessary for drawing a figure .....	22
4-way valve switching assurance .....	421
7-Segment display .....	410, 435, 472
7-segment display in abnormal circumstances .....	469

## A

A single outdoor unit .....	366, 369
Abnormal stop due to abnormal compressor start .....	406
About power failure compensation .....	595
About the setting of central controller / remote controller .....	577
Additional Refrigerant Charge .....	348
Address check .....	618
Address Setting FDCA140HKXEN4 .....	358
FDCA224HKXE4 ~ FDCA1360HKXE4 .....	361
Address setting method and setting of address switches .....	361
Address setting switches and their location .....	362
Adiabatic expansion .....	23
Air Tightness Test .....	347
Allowable length of refrigerant piping, height difference between indoor and outdoor unit FDCA140HKXEN4 ~ 680HKXE4 (integrated) .....	337
FDCA735HKXE4 ~ A1360HKXE4 (Combination use) .....	338
Amount of Ambient Air .....	28
Anchor bolt positions .....	251
Anomalous high pressure increase protection .....	428
Anomalous high pressure increase protection (Main unit, sub unit) .....	464
Approximate value of average acoustic absorptivity $\bar{\alpha}$ (at about 500Hz) .....	64
Auto swing control (FDT, FDTW, FDTQ, FDTs, FDE and FDK only) .....	393
Automatic address setting .....	358, 364
Automatic backup operation (Main unit / sub unit) .....	466

## B

Base .....	251
Before Starting Troubleshooting .....	636
Branch pipe set shapes .....	335

Building a diversified control system meeting the diversified air-conditioning demands of large buildings .....	487
---	-----

## C

Cable for Remote Control Wiring .....	381
Calculation of Air-conditioning Load and Model Selection .....	25
Calculation of Noise Level Indoor .....	63
Outdoor .....	64
Calculation of system capacity .....	31
Capacity calculation method .....	31
Capacity calculation of indoor unit .....	31
Capacity compensation calculation of indoor unit .....	31
Capacity compensation calculation of outdoor unit .....	31
Carry-in .....	251
Carry-in and Installation of Unit .....	251
Casseteria Type (FDRA) Specifications .....	166
Ceiling Mounted Duct Type (FDURA) Specifications .....	193
Ceiling Recessed Compact Type (FDTCA) Specifications .....	133
Ceiling Recessed Single Air Supply Port Type (FDTQA) Specifications .....	149
Ceiling Recessed Type (FDTA) Specifications .....	122
Ceiling Suspension Type (FDEA) Specifications .....	202
Center console SLA-2A-E .....	491
Central Console SLA-3-E .....	515
Central console SLA-3-E .....	493
Central controller Overview .....	499
Central Controller SLA-1-E .....	491, 505, 573
Changes when air-conditioner is actually installed .....	64
Characteristics of fan FDQMA22KXE4A, 28KXE4A, 36KXE4A .....	181
FDUMA112KXE4A .....	191
FDUMA140KXE4A .....	191
FDUMA45KXE4A, 56KXE4A .....	190
FDUMA71KXE4A .....	191
FDUMA90KXE4A .....	191
FDURA112KXE4A .....	200
FDURA140KXE4A .....	200
FDURA45KXE4A .....	199
FDURA56KXE4A .....	199
FDURA71KXE4A .....	199
FDURA90KXE4A .....	199
FDRA112KXE4A .....	175

FDRA140KXE4A .....	176	Constant quality of vapor line .....	22
FDRA71KXE4A .....	175	Constant relative humidity line .....	58
FDRA90KXE4A .....	175	Constant specific volume line .....	59
FDRA45KXE4A, 56KXE4A .....	175	Constant specific volume line [m <sup>3</sup> / kg] .....	22
FDTQA22, 28, 36KXE4A .....	158	Constant wet bulb temperature line .....	58
SAF1000E4 .....	232	Control activation conditions .....	468
SAF250E4 .....	231	Control for a single unit .....	381
SAF350E4 .....	231	Control for operating permission, prohibition, and coin timer .....	396
SAF500E4 .....	231	Control of increasing and decreasing of compressor frequency .....	421
SAF800E4 .....	232	Control termination conditions .....	468
Check before test run .....	616	Cooling and heating forced operation .....	403
Check before test runs .....	600	Cooling high pressure control .....	423, 452
Check Indicator Table .....	637	Cooling low pressure control .....	423
Check insulation, power supply voltage .....	617	Cooling low pressure control (Main unit) .....	452
Check method for operation of the indoor electronic expansion valve of indoor unit .....	684	Cooling operation .....	391
Check on use limitations related with equipment designs .....	598, 693	Cooling with constant moisture .....	60
Check pairing by actual operation .....	622	Cooling with dehumidification .....	60
Check related to installation .....	615	Correction of cooling and heating capacity in relation to one way length of refrigerant piping Cooling operation .....	38
Check related with construction .....	599, 695	Heating operation .....	41
Check the use restrictions related to equipment design (KX4 8 horsepower or more) .....	615	Counter Measures for Exceeding the Critical Concentration (JRA-GL 13-1998) .....	689
Check to be sure that outdoor unit service valve has been opened...must check before operation .....	617	Crankcase heater control .....	422, 451
Check whether signal wires are mixed...check before power is turned on .....	616	Current cut control .....	428
Checking the power transistor module (including the drive circuit) .....	681	Current cut control (Main unit · sub unit) .....	464
Combination air-conditioners .....	27	Current safe control .....	403, 427
Combination unit .....	469	Current safe control (Main unit / sub unit) .....	463
Combinational outdoor units .....	367, 370	<b>D</b>	
Component description and function .....	573, 575, 588	Data items to be checked on the unit side during test run / data collection method .....	611
Composition of air chart .....	58	Day-off setting .....	593
Compression .....	23	Defrosting .....	401, 425
Compression of refrigerant .....	10	Defrosting (Main unit / sub unit) .....	455
Compression ratio protection control .....	432, 457	Dehumidifying (Thermal dry) .....	391
Compressor abnormal rotor lock .....	406	Demand control .....	408, 434, 470
Compressor operating frequency decision .....	399	Demand unit setting method .....	583
Compressor pre-start control (Main unit / sub unit) .....	449	Description of KX4 Series .....	72
Compressor protection at low frequency .....	405, 426	Detailed Description of the System Machines .....	505
Compressor protective control .....	403	Diagnosis by the power supply reset .....	644
Compressor protective start .....	422	Discharge pipe temperature control .....	427
Compressor protective start control (Main unit / sub unit) .....	462	Discharge pipe temperature control (Main unit / sub unit) .....	462
Compressor start control between outdoor units (Main unit / sub (remote) unit) .....	447	Discharge temperature control .....	403
Compressor starting control .....	399	Display sequence of error, inspection display lamp .....	642
Compressor starting order and load classes .....	446	Drawing No. of spare parts for inverter PCB .....	663
Condensate pump motor (DM) control (Only FDT, FDTW, FDTQ, FDTs, FDR, FDQM, FDUM models) .....	394	<b>E</b>	
Condensation .....	23	E1 .....	655
Confirmation of time set by timer .....	594	E10 .....	658
Confirmation Procedure for Critical Concentration and Refrigerant Concentration .....	688	E11 .....	658
Constant dew point temperature line .....	58	E12 .....	658
Constant entropy line [kJ / kg·K] .....	22	E16 .....	659
		E2 .....	656
		E28 .....	660
		E3 .....	668
		E30 .....	670

E31 .....	670	FDKA22KXE4A, 28KXE4A, 36KXE4A, 45KXE4A, 56KXE4A.....	213
E32 .....	670	FDKA71KXE4A.....	214
E35 .....	671	FDTA112KXE4A, 140KXE4A .....	131
E36 .....	671	FDTA28KXE4A, 36KXE4A, 45KXE4A, 56KXE4A, 71KXE4A, 90KXE4A .....	130
E36-1 .....	671	FDTCA22KXE4A, 28KXE4A, 36KXE4A, 45KXE4A, 56KXE4A.....	137
E37 .....	672	SAF250E4, 350E4, 500E4.....	229
E37-1.....	672	SAF800E4, 1000E4 .....	230
E37-2 .....	672	Emergency stop control .....	432, 468
E37-3 .....	672	Enthalpy [kJ / kg].....	21
E37-4 .....	672	Error Diagnosis Procedures at the Indoor Unit Side .....	650
E37-5 .....	672	Error Diagnosis Procedures at the Outdoor Unit Side.....	661
E37-6 .....	672	Estimated Value of the Cooling Load (per m <sup>2</sup> of floor area).....	27
E38 .....	672	Evacuation .....	347
E39 .....	673	Evaluate by remote controller and 7 segment display .....	627
E39-1 .....	673	Evaluation by actual operation .....	612
E39-2.....	673	Evaporation .....	22
E40 .....	673	Example of Refrigerant Piping .....	343
E41 .....	674	Exchange Unit (SAF) Specifications.....	222
E41-1 .....	674	Expansion of refrigerant .....	12
E41-2 .....	674	Exterior appearance All models .....	129, 136, 146, 156, 163, 172, 206
E42 .....	675	FDKA22 ~ 56KXE4A.....	212
E42-1 .....	675	FDKA71KXE4A.....	212
E42-2 .....	675	Floor standing exposed type (FDFL) .....	219
E43 .....	676	Floor standing hidden type (FDFU) Zinc steel plate.....	219
E45 .....	676	Exterior Dimensions FDCA140HKXEN4.....	104
E45-1 .....	676	FDCA224HKXE4, 280HKXE4 .....	105
E45-2 .....	676	FDCA335HKXE4, 335HKXE4-K, 400HKXE4, 450HKXE4 .....	106
E46 .....	677	FDCA504HKXE4, 560HKXE4, 615HKXE4, 680HKXE4 .....	107
E48 .....	677	Exterior dimensions FDEA112KXE4A, 140KXE4A .....	206
E48-1 .....	677	FDEA36KXE4A, 45KXE4A, 56KXE4A .....	205
E48-2 .....	677	FDEA71KXE4A.....	205
E49 .....	678	FDKA22KXE4A, 28KXE4A, 36KXE4A, 45KXE4A, 56KXE4A.....	211
E5 .....	669	FDKA71KXE4A.....	211
E53 .....	678	FDQMA22KXE4A, 28KXE4A, 36KXE4A .....	179
E54 .....	679	FDRA112KXE4A, 140KXE4A .....	171
E54-1 .....	679	FDRA45KXE4A, 56KXE4A.....	169
E54-2 .....	679	FDRA71KXE4A, 90KXE4A.....	170
E59 .....	679	FDTA112KXE4A, 140KXE4A .....	128
E59-1 .....	679	FDTA28KXE4A, 36KXE4A, 45KXE4A, 56KXE4A, 71KXE4A.....	126
E59-2 .....	679	FDTA90KXE4A .....	127
E6 .....	656	FDTCA22KXE4A, 28KXE4A, 36KXE4A, 45KXE4A, 56KXE4A.....	135
E60 .....	680	FDTQA22KXE4A, 28KXE4A, 36KXE4A .....	152
E60-1 .....	680	FDTSA45KXE4A .....	161
E60-2 .....	680		
E63 .....	680		
E7 .....	657		
E9 .....	657		
Effect when there is obstacle on the way .....	65		
Electric Wiring .....	352		
Electric Works for Air-to-air Heat Exchange Units .....	374		
Electrical Wiring FDCA140HKXEN4 .....	111		
FDCA224HKXE4, 280HKXE4 .....	112		
FDCA335HKXE4 .....	113		
FDCA335HKXE-K, 400HKXE4, 450HKXE4, 504HKXE4, 560HKXE4, 615HKXE4, 680HKXE4.....	114		
Electrical wiring All models .....	136, 147, 157, 164, 173,		

- FDTSA71KXE4A .....162  
 FDTWA112KXE4A, 140KXE4A.....145  
 FDTWA28KXE4A, 45KXE4A, 56KXE4A .....143  
 FDTWA71KXE4A, 90KXE4A.....144  
 FDUMA112KXE4A, 140KXE4A.....188  
 FDUMA45KXE4A, 56KXE4A.....186  
 FDUMA71KXE4A, 90KXE4A.....187  
 FDURA45KXE4A, 56KXE4A, 71KXE4A .....196  
 FDURA90KXE4A, 112KXE4A, 140KXE4A ....197  
 Floor standing exposed type (FDFLA).....218  
 Floor standing hidden type (FDFUA) .....218  
 SAF1000E4 .....228  
 SAF250E4 .....224  
 SAF350E4 .....225  
 SAF500E4 .....226  
 SAF800E4 .....227  
 External control (remote display) / control of input  
 signal.....396  
 External input operation and demand input .....469  
 External input operation and  
 demand input operation .....408, 433
- F**
- Fault diagnosis circuit diagram  
 for outdoor unit controller .....665  
 Fault indication list of CHC.....536  
 Feature of Outdoor Unit  
 FDCA140HKXEN4 (5HP) .....75  
 FDCA224HKXE4 ~  
 FDCA1360HKXE4 (8HP ~).....77  
 Feature of the Indoor Unit  
 Ceiling filling caseteria type FDRA .....84  
 Ceiling hanging type FDEA .....86  
 Convertible type FDURA suitable for  
 both ceiling filling caseteria type  
 and duct type .....86  
 Floor standing exposed type FDFLA / floor  
 standing hidden type FDFUA.....87  
 Four directional air blowing ceiling filling type  
 FDTA .....81  
 High static pressure duct type FDUA.....85  
 Low static pressure duct type  
 compact FDQMA .....84  
 Middle static pressure duct type FDUMA .....85  
 One directional air blowing ceiling filling type  
 compact FDTQA .....83  
 One directional air blowing ceiling filling type  
 FDTSA .....83  
 Total heat exchanger unit SAF .....88  
 Two directional air blowing ceiling  
 filling type FDTWA .....82  
 Wall mounted type FDKA .....87  
 Features of Refrigerant .....7  
 FILTER sign .....393  
 Floor Standing Exposed Type (FDFLA / FDFUA)  
 Specifications .....216  
 Floor standing exposed type (FDFLA) .....216  
 Floor standing hidden type (FDFUA) .....217  
 Flow of test runs (Details will be described  
 from next pages) .....605  
 Flowchart of Countermeasures Against  
 Refrigerant Leakage..... 692  
 For a finite long barrier ..... 67  
 Forced heating / cooling operation ..... 431  
 Forced heating / cooling operation (Main unit) ..... 466  
 Four way valve does not switch  
 during heating operation ..... 684  
 Frost prevention during cooling, dehumidifying.... 394  
 Function of CHC..... 530  
 Function of DIP switch (SW3, 4, 5) ..... 661  
 Function of DIP switches (SW5, 9)..... 652  
 Function of DIP switches (SW9)..... 652  
 Function of jumper wires ..... 651  
 Functions of CHC-MFE ..... 531  
 Functions of components ..... 13  
 Functions of the Control Circuit Board of  
 the Outdoor Unit  
 Control cabinet of the outdoor unit KX4 series  
 (12 - 24 HP) ..... 686  
 Control cabinet of the outdoor unit KX4 series  
 (5 - 12 HP) ..... 685  
 Fuzzy control ..... 484
- G**
- Generated load (heat generated inside ) ..... 26  
 Group operation method ..... 578  
 Group setting method..... 576
- H**
- Hand over to the installation consigner ..... 612  
 Header pipe set shapes ..... 336  
 Heat Generation of Illumination Machine ..... 28  
 Heater control..... 393  
 Heating and Condensation Prevention ..... 349  
 Heating high pressure control ..... 423  
 Heating high pressure control  
 (Main unit only)..... 453  
 Heating low pressure control..... 424  
 Heating low pressure control  
 (Main unit / sub unit)..... 453  
 Heating operation ..... 392  
 Heating with humidification ..... 60  
 Heating with no humidification ..... 59  
 High ceiling control ..... 395  
 High pressure control ..... 403  
 High pressure protective control ..... 427, 463  
 High pressure ratio protection control ..... 405  
 Household air-conditioners ..... 27  
 How to determine discharged air  
 temperature and sensible heat factor  
 (ratio) of air conditioner ..... 61  
 How to use psychrometric chart..... 58  
 How to use the P-h chart..... 21
- I**
- Individual operation method ..... 574, 580  
 Individual setting method ..... 577  
 Indoor expansion valve control ..... 395  
 Indoor fan abnormal ..... 396  
 Indoor Unit..... 122  
 Indoor unit connection number protection ..... 433  
 Indoor unit connection number protection

- (Main unit only) .....469
- Indoor unit operation flowchart
- Cooling operation .....646
  - Fan operation .....648
  - Heating operation .....647
  - Program dry operation .....648
- Indoor unit refrigerant recovery control .....432, 456
- Inside View
- FDCA140HKXEN4 .....108
  - FDCA224HKXE4, 280HKXE4, 335HKXE4.....109
  - FDCA335HKXE4-K, 400HKXE4, 450HKXE4,  
504HKXE4, 560HKXE4, 615HKXE4,  
680HKXE4 .....110
- Inspection / normal List of power display .....636
- Inspection Method When
- There Is No Error Display .....683
- Installation check.....615
- Installation check and confirmation
- before test run .....612
- Installation Manual of
- Central Controller SLA-2A-E .....586
- Installation Manual of Weekly Timer .....596
- Installation of Indoor Unit
- 1-way Outlet Ceiling Recessed Type  
(FDTSA).....280
  - 2-way Outlet Ceiling Recessed Type  
(FDTWA).....266
  - Casseteria Type (FDRA) .....286
  - Ceiling Mounted Duct Type (FDURA).....306
  - Ceiling recessed compact type (FDTCA) .....260
  - Ceiling Recessed Single Air Supply Port Type  
(FDTQA) .....272
  - Ceiling Recessed Type (FDTA) .....253
  - Ceiling Suspension Type (FDEA) .....314
  - Floor Standing Exposed Type (FDFLA).....324
  - Medium Static Pressure Ducted Type  
(FDQMA) .....296
  - Satellite Ducted Type (FDUMA) .....300
- Installation of Outdoor Unit.....246
- Installation of Remote Controller
- (Optional Parts).....377, 378
- Installation Sequence .....244
- Installation Space (Service Space) Example
- FDCA140HKXEN4 .....246
  - FDCA224 ~ 1360HKXE4 .....249
- Interface equipment .....497, 498
- Interface equipment SC-LIF-E .....497
- Introduction .....361
- Inverter cooling fan control.....426
- Inverter cooling fan control (Main unit / sub unit) ..461
- Inverter error .....405
- Isenthalpic line .....58
- Isothermal (constant temperature line) .....22
- J**
- Judgment on Mixture of Signal Wires and Power
- Source Wires .....357
- K**
- Key points of indoor unit selection .....53
- KX4 Construction Check Sheet.....696
- KX4 construction checklist ..... 632
- KX4 Equipment Design Check Sheet ..... 694
- KX4 Multi Standard Data Sheet  
(for Mente PC)..... 630
- KX4 Multi Standard Data Sheet  
(for new remote controller) ..... 631
- KX4 Test Run Check Sheet ..... 699
- L**
- Liquefaction of refrigerant ..... 9
- List of Functions ..... 499
- List of indoor units ..... 73
- List of outdoor units ..... 72
- List of the System Machine Combination ..... 504
- Load of infiltration (Amount of conductive heat and  
radiant heat) ..... 26
- Load of ventilation  
(cooling of outdoor infiltration air) ..... 26
- Louver auto horizontal set during heating ..... 394
- Louver Control..... 393
- Louver free stop control ..... 394
- Louver motor does not operate ..... 683
- Low pressure control ..... 404
- Low pressure protective control ..... 429
- Low pressure protective control  
(Main unit only)..... 465
- M**
- Manual address setting ..... 360, 365
- Medium Static Pressure Ducted Type  
(FDQMA) Specifications..... 178
- Method for judging operating condition ..... 682
- Method of address setting ..... 361
- Method of checking address
- by remote controller  
and 7 segment display ..... 619
- Method of checking pairing by MentePC ..... 622
- Method of checking pairing
- by remote controller  
and 7 segment display ..... 624
- Method of clearing setting details..... 593
- Method of Connecting Power Cables..... 353
- Method of Connecting Signaling Wires ..... 356
- Method of determining state of  
refrigerant by the chart ..... 22
- Method of Operating Service Valves..... 348
- Method of unit evaluation by MentePC ..... 624
- Mixing of airstreams ..... 61
- Model change over switch (SW4)..... 663
- Model Description
- Indoor unit..... 74
  - Outdoor unit ..... 74
- Model select switch (SW6) ..... 652
- Model Selection ..... 29
- Model selection flow ..... 30
- Movement on Psychrometric Chart ..... 59
- Multiple units control-simultaneous control  
of 16 unit with one remote controller ..... 381, 397
- N**
- Noise Level

Outdoor unit.....	119	Notices when noise barrier is installed.....	65
Noise level		Number of Persons Indoor.....	28
FDEA 36KXE4A, 45KXE4A, 56KXE4A.....	208	<b>O</b>	
FDEA112KXE4A.....	208	Oil equalization control (Main unit / sub unit).....	459
FDEA140KXE4A.....	208	Oil equalization rotation (Main unit / sub unit).....	458
FDEA71KXE4A.....	208	Oil return control.....	430
FDFLA28KXE4, FDFUA28KXE4.....	221	Oil return control (Main unit / sub unit).....	457
FDKA22KXE4A, 28KXE4A.....	215	Oil separator bypass valve (SV3) control (SV2 is always turning ON while the compressor is operating.).....	406
FDKA36KXE4A.....	215	Oil separator solenoid valve (SV6) control.....	420
FDKA45KXE4A.....	215	Oil separator solenoid valve (SV6, 7) control.....	450
FDKA56KXE4A.....	215	One of the following measures should be taken in case of faulty construction.....	611
FDKA71KXE4A.....	215	On-site Piping Work.....	345
FDLA45KXE4, 71KXE4, FDFUA45KXE4, 56KXE4, 71KXE4.....	221	Operation chart	
FDQMA 22KXE4A, 28KXE4A, 36KXE4A.....	182	Operating characteristic of indoor unit.....	236
FDRA112KXE4A.....	177	Operating characteristic of outdoor unit.....	100
FDRA140KXE4A.....	177	Operation Control Function	
FDRA45KXE4A, 56KXE4A.....	177	by the Indoor Controller.....	391
FDRA71KXE4A, 90KXE4A.....	177	Operation Control Function by the Outdoor Controller	
FDTA112KXE4A.....	132	Standard Combination Multi-Unit	
FDTA140KXE4A.....	132	FDCA335HKXE4-K, FDCA400HKXE4 ~ FDCA1360HKXE4.....	446
FDTA28KXE4A, 36KXE4A, 45KXE4A.....	132	Standard Multi-Unit FDCA140HKXE4.....	399
FDTA56KXE4A.....	132	Standard Multi-Unit FDCA224, 280, 335HKXE4.....	420
FDTA71KXE4A.....	132	Operation details setting method.....	581
FDTA90KXE4A.....	132	Operation Flowcharts.....	645
FDTCA22KXE4A, 28KXE4A.....	138	Operation Instructions.....	573
FDTCA36KXE4A.....	138	Operation permission / prohibition control.....	469
FDTCA45KXE4A.....	138	Operation permission / prohibition mode.....	408, 433
FDTCA56KXE4A.....	138	Operation/error output.....	397
FDTQA 22KXE4A, 28KXE4A, 36KXE4A.....	159	Operations of major functional items under each operation mode.....	420, 446
FDTQA22KXE4A, 28KXE4A, 36KXE4A.....	159	Outdoor fan control.....	400, 421
FDTSA45KXE4A.....	165	Outdoor fan control (Main unit / sub unit).....	451
FDTSA71KXE4A.....	165	Outdoor fan motor (DC) anomaly protection.....	429
FDTWA 28KXE4, 45KXE4, 56KXE4.....	148	Outdoor fan motor (DC) anomaly protection (Main unit / sub unit).....	465
FDTWA112KXE4.....	148	Outdoor Unit	
FDTWA140KXE4.....	148	Specifications.....	89
FDTWA71KXE4.....	148	Outdoor Units / List of Indoor Units.....	72
FDTWA90KXE4.....	148	Outdoor unit combination protection (Main unit only).....	469
FDUMA 45KXE4A, 56KXE4A, 71KXE4A.....	192	Outdoor unit operation flowchart	
FDUMA112KXE4A.....	192	Cooling operation.....	650
FDUMA140KXE4A.....	192	Outline of Operation Control	
FDUMA36KXE4A.....	192	by Microcomputer.....	386
FDUMA90KXE4A.....	192	<b>P</b>	
FDURA112KXE4A.....	201	Pairing (indoor / outdoor units combination) check.....	621
FDURA140KXE4A.....	201	Parts layout on the outdoor unit PCB.....	661
FDURA45KXE4A.....	201	P-h Chart.....	16
FDURA56KXE4A.....	201	P-h chart.....	21
FDURA71KXE4A.....	201	Pipe Size Selection.....	334
FDURA90KXE4A.....	201	Piping Material Selection.....	342
SAF1000E4.....	235	Piping outline of equalizer oil piping.....	341
SAF250E4.....	233		
SAF350E4.....	233		
SAF500E4.....	234		
SAF800E4.....	234		
Notabilia as a Unit Designed for R410A.....	350		
Notabilia for Installation.....	251		
Notice on calculation of air-conditioning load and model selection.....	35		
Notice on Design and Wiring of Electric Equipment.....	373		
Notice on Installation.....	333		

- Piping System  
 FDCA140HKXEN4 ..... 115  
 FDCA224HKXE4, 280HKXE4 ..... 116  
 FDCA335HKXE4 ..... 117  
 FDCA335HKXE4-K, 400 ~ 680HKXE4..... 118
- Points for test run when using QSS  
 (the checker of air conditioner) ..... 610
- Points for test runs ..... 604
- Points to be noticed in model selection ..... 54
- Power Supply Wiring ..... 354
- Power transistor temperature control ..... 404, 428
- Power transistor temperature control  
 (Main unit · sub unit) ..... 464
- Precaution in Electric Wiring ..... 355
- Pressure [MPa] ..... 21
- Procedure of test run ..... 598
- Procedures of trouble diagnosis ..... 643
- Psychrometric Chart ..... 55
- Psychrometric chart ..... 55, 56
- Psychrometric Chart (NC chart) ..... 57
- Pump down control ..... 407, 431
- Pump down control (Main unit / sub unit) ..... 467
- Purpose ..... 621
- Purpose of test runs ..... 604
- R**
- R22 (CHClF<sub>2</sub>) P-h chart ..... 18
- R407C (CH<sub>2</sub>F<sub>2</sub>/C<sub>2</sub>HF<sub>5</sub>/CH<sub>2</sub>FCF<sub>3</sub>) P-h chart ..... 16
- R410A (CH<sub>2</sub>F<sub>2</sub>/CHF<sub>2</sub>CF<sub>3</sub>) P-h chart ..... 17
- Range of Usage & Limitations ..... 121
- Range of usage & limitations or Coefficient  
 of cooling and heating capacity in relation  
 to temperatures ..... 36
- References ..... 630
- Refrigerant Characteristics ..... 19
- Refrigerant Piping ..... 334
- Refrigerant recovery control ..... 406
- Refrigeration Cycle ..... 6
- Refrigeration cycle drawn in P-h chart ..... 24
- Refrigeration Principle ..... 6
- Remote control address setting ..... 359, 368
- Remote Controller (Optional Parts) ..... 377
- Remote Controller Wiring Specifications ..... 356
- Replacement parts assembly related  
 to the outdoor unit PCB ..... 661
- Restrictions on the Use of Pipes ..... 342
- Room Area ..... 28
- S**
- Safety Precautions ..... 242
- Safety Solutions for Refrigerant Leakage ..... 688
- Satellite Ducted Type (FDUMA)  
 Specifications ..... 183
- Saturated air line ..... 58
- Saturated liquid line ..... 21
- Saturated vapor line ..... 21
- Saving of Operation Data ..... 415
- Saving of operation data ..... 477
- Scale of sensible heat factor (ratio) ..... 59
- Selecting the Installation Location ..... 246
- Service tool required for test run ..... 613
- Set procedure of the checker ..... 681
- Setting Functions Using the  
 Remote Controller ..... 380, 387
- Setting of programmed operation ..... 590
- Silent mode control ..... 401, 430
- Silent mode control (Main unit / sub unit) ..... 456
- Simple and clean mechanism control  
 (for FDKA28~45 model only) ..... 394
- Simple Calculation Method (HASS112) ..... 27
- Simultaneous operation method ..... 574, 578
- Snow protection fan control ..... 431
- Snow protection fan control  
 (Main unit / sub unit) ..... 466
- Starting the compressor  
 (Main unit / sub unit) ..... 448
- State change of air on Psychrometric Chart ..... 59
- Sub cooling coil control ..... 454
- Submission to Entrusted Construction Unit ..... 629
- Super Link BACnet Gateway SC-BGW-A ..... 566
- Super Link LON Gateway  
 SC-LGW-A ..... 557  
 SC-LIF-E ..... 548
- Super Link Serial Gateway CHC ..... 528
- Super Link Web Gateway SC-WGW-A ..... 538
- Supercooling coil control ..... 424
- Switching by J13 ~ 15  
 (With short / None open) ..... 662
- System Features ..... 484
- System Overview  
 Specifications ..... 500
- T**
- Table of various refrigerant characteristics ..... 19
- Temperature and Pressure  
 in Refrigeration Cycle ..... 14
- Temperature and pressure  
 of various refrigerants ..... 20
- Temperature condition defrosting ..... 425, 455
- Temperature in refrigeration cycle ..... 14
- Test operation ..... 407
- Test operation mode ..... 426, 461
- Test Run  
 Standard and Combination Multi  
 (FDCA224HKXE4 ~  
 FDCA1360HKXE4) ..... 611  
 Standard Multi (FDCA140HKXEN4) ..... 598
- Test run points when operating data  
 display function and outdoor 7  
 segment function of remote  
 controller are used. .... 605
- The basic feature of t- x air diagram ..... 58
- The meaning and effect of test run ..... 611
- The purpose of test run ..... 611
- The total flow of test run ..... 612
- There are two types of pressures  
 in the refrigeration cycle ..... 14
- Thermal Load Analysis ..... 26
- Thermistor (Return air, heat exchanger)  
 disconnected ..... 396
- Thermistor and pressure sensor disconnection  
 (discharge · suction · outdoor heat exchanger ·



under-dome,outdoor air, temperature).....	407
Time condition defrosting	
(oil return).....	425, 455
Timer operation method .....	582
Troubleshooting .....	636
Types of heat .....	11

**U**

Under-dome temperature control.....	426
Under-dome temperature control	
(Main unit / sub unit) .....	462
Unit evaluation by test run switch (SW) .....	624
Unit protective maintenance related devices .....	426
Unit protective maintenance related devices	
(Main unit only) .....	461
Usage guidance .....	585

**V**

Value shift adjustment of room air temperature	
detection in heating.....	393
Vapor partial pressure.....	59
Vaporization of refrigerant.....	8
Ventilation fan control (Main unit / sub unit) .....	468
Vibration isolating rubber .....	252

**W**

Wall Mounted Type (FDK)	
Specifications .....	209
Week & current time setting .....	589
Weekly Timer (SCA-WT-E) .....	494
Weekly Timer SCA-WT-E .....	526, 588
Wet air h-x chart (SI) .....	55
What is the Calculation of Air-conditioning Load? ...	25
When mounted on the wall like a separate type .....	65
When mounted on the wall like an integrated air	
conditioner .....	64
When test run is to be finished, check to be	
sure that there are no faults found and	
no faults will happen. ....	611
When the check display appears .....	594
When the filter sign lights .....	584
When the indoor unit blower does not operate .....	683
When the operation / abnormality	
display lamp lights in red.....	584
When the operation / check display lamp	
is red light on.....	574
Window Area Ratio .....	28
Wired Remote Controller (Optional Parts) .....	386
Wiring System Diagrams.....	353