

**60 Hz**



# HM - HMS Series

THREADED HORIZONTAL MULTISTAGE CENTRIFUGAL ELECTRIC PUMPS  
EQUIPPED WITH IE2/IE3 MOTORS COMPLYING WITH REGULATION (EC) no. 640/2009

**HM - HMS SERIES  
HYDRAULIC PERFORMANCE RANGE AT 60 Hz**

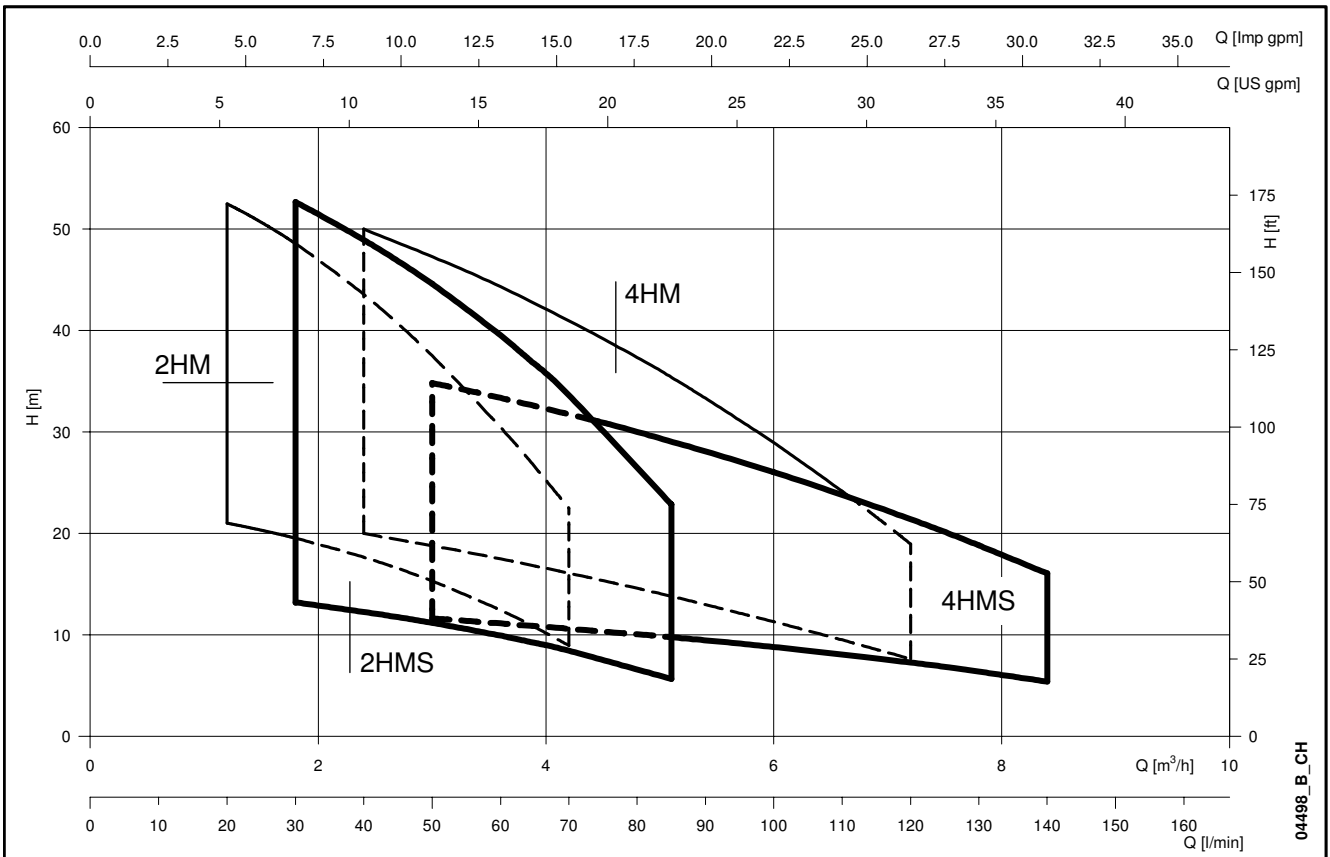

## **CONTENTS**

HM-HMS series specifications .....	<b>5</b>
List of models and table of materials HM series .....	<b>7</b>
List of models and table of materials HMS series .....	<b>8</b>
Mechanical seal HM-HMS series .....	<b>9</b>
Hydraulic performance table and electrical data HM series .....	<b>11</b>
Hydraulic performance table and electrical data HMS series .....	<b>12</b>
Motors for HM-HMS series .....	<b>13</b>
Hydraulic performance range HM-HMS series at 60 Hz .....	<b>15</b>
Dimensions and weights HM-HMS series .....	<b>20</b>
Technical Appendix .....	<b>21</b>



## Threaded horizontal multistage centrifugal electric pumps

### HM-HMS 60 Hz Series

#### MARKET SECTORS

INDUSTRIAL, CIVIL, AGRICULTURAL.

#### APPLICATIONS

- Pumping of water for domestic (HM) and industrial use (HMS).
- Small irrigation systems. The HMS series pump can handle water (containing additives) having moderate chemical aggressiveness, but free of suspended solids.
- Composition of pressure booster units for various purposes.
- Pumping of liquids compatible with AISI 316L stainless steel (1.4404) for HMS version.



- Liquid end made entirely of stainless steel for HMS**
- Silent operation**
- High performance and reliability**
- Standard supplied IE2/IE3 motors are compliant with Regulation (EC) no. 640/2009.**

#### SPECIFICATIONS PUMP

- **Delivery:**  
2HM-4HM: up to 120 l/min (7,2 m<sup>3</sup>/h).  
2HMS-4HMS: up to 140 l/min (8,4 m<sup>3</sup>/h).
- **Head:**  
2HM-4HM: up to 57,9 m.  
2HMS-4HMS: up to 61,8 m.
- **Maximum operating pressure:**  
800 kPa (8 bar, PN 8).
- **Temperature of pumped liquid:**  
HM: -10°C to +60°C.  
HMS: -10°C to +90°C for household use (EN 60335-1).  
-10°C to +110°C for industrial/commercial use.

#### MOTOR

- Asynchronous, squirrel cage rotor, close construction, external ventilation.
- **Protection class:**  
IP55 (motor), IPX5 (electric pump).
- **Class 155 (F) Insulation.**
- According to EN 60034-1.
- **Standard voltage:**
  - **Single-phase** versions:  
220-230 V 60 Hz, 2 poles, with automatic reset overload protection.
  - **Three-phase** versions:  
220-230/380-400 V 60 Hz, 2 poles, the overload protection must be provided and installed by the user.

## HM-HMS SERIES IDENTIFICATION CODE

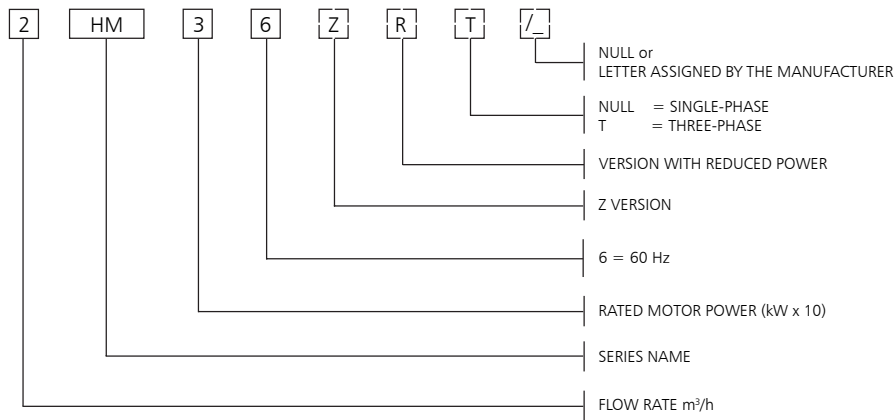

EXAMPLE : 2HM36T  
 HM electric pump series, flow rate 2 m<sup>3</sup>/h  
 rated motor power 0,3 kW, 60 Hz, three-phase.

## RATING PLATE

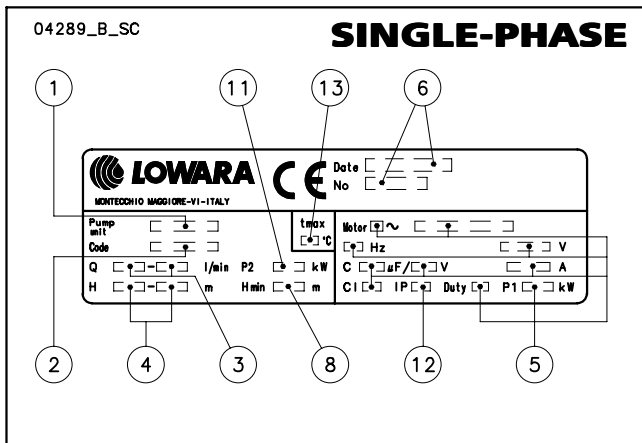

## LEGEND

- 1 - Electric pump type
- 2 - Code
- 3 - Delivery range
- 4 - Head range
- 5 - Electrical data
- 6 - Serial number (date + sequential number)
- 8 - Minimum head
- 11 - Rated power
- 12 - Electric pump protection class
- 13 - Maximum temperature of pumped liquid

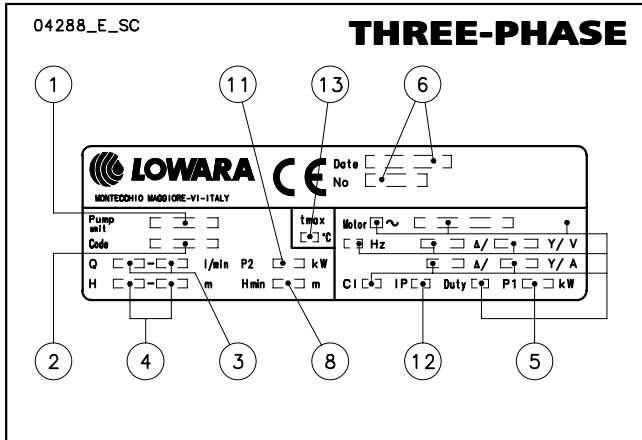

## HM SERIES LIST OF MODELS AND TABLE OF MATERIALS

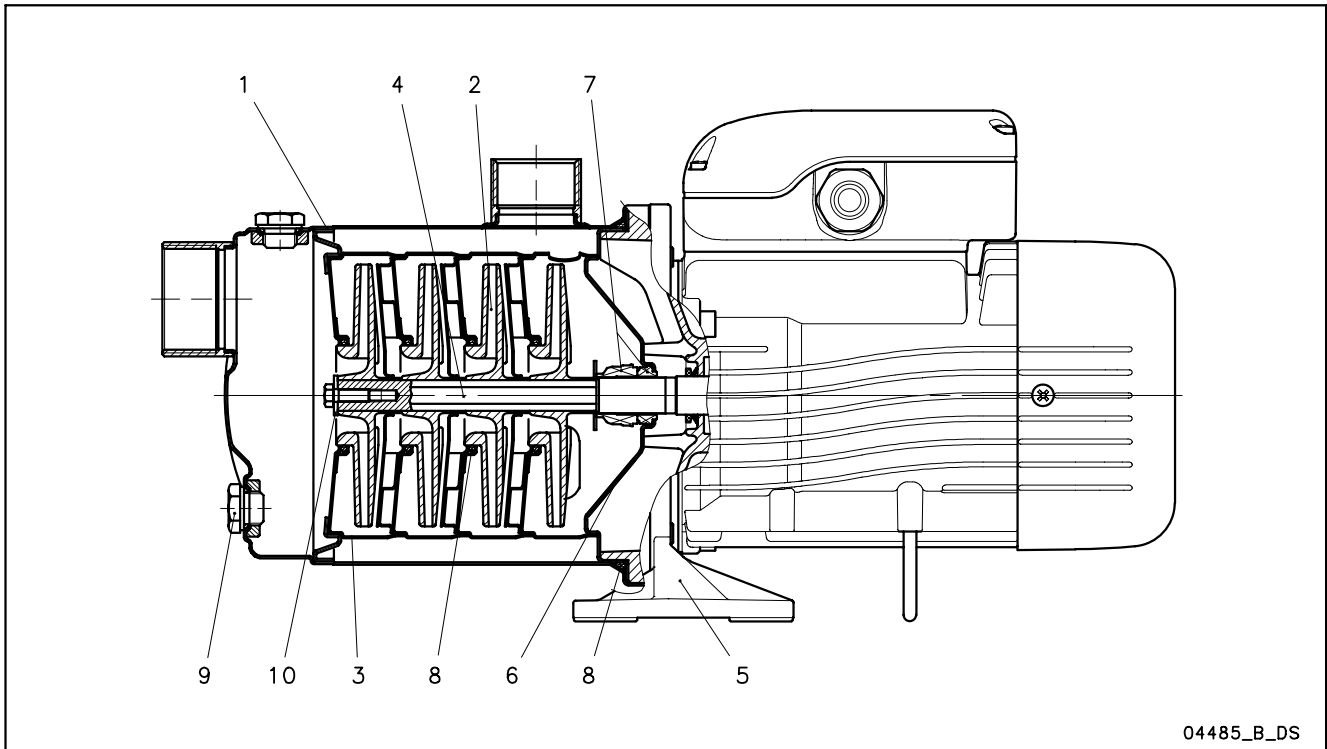

04485\_B\_DS

## HM SERIES TABLE OF MATERIALS

REF. N.	NAME	MATERIAL	REFERENCE STANDARDS	
			EUROPE	USA
1	Pump body	Stainless steel	EN 10088-1-X5CrNi18-10 (1.4301)	AISI 304
2	Impeller	Noryl®		
3	Diffuser	Stainless steel	EN 10088-1-X5CrNi18-10 (1.4301)	AISI 304
4	Shaft extension	Stainless steel	EN 10088-1-X5CrNiMo17-12-2 (1.4401)	AISI 316
5	Adapter	Aluminium	EN 1706-AC-AISI11Cu2 (Fe) (AC46100)	-
6	Seal housing	Stainless steel	EN 10088-1-X5CrNi18-10 (1.4301)	AISI 304
7	Mechanical seal	Ceramic / Carbon / EPDM (standard version)		
8	Elastomers	EPDM		
9	Fill / drain plugs	Nickel-plated brass	EN 12164-CuZn39Pb3 (CW614N)	-
10	Bolts and screws	Stainless steel	EN 10088-1-X5CrNi18-10 (1.4301)	AISI 304

hm-hmz-en\_b\_tm

## HMS SERIES LIST OF MODELS AND TABLE OF MATERIALS

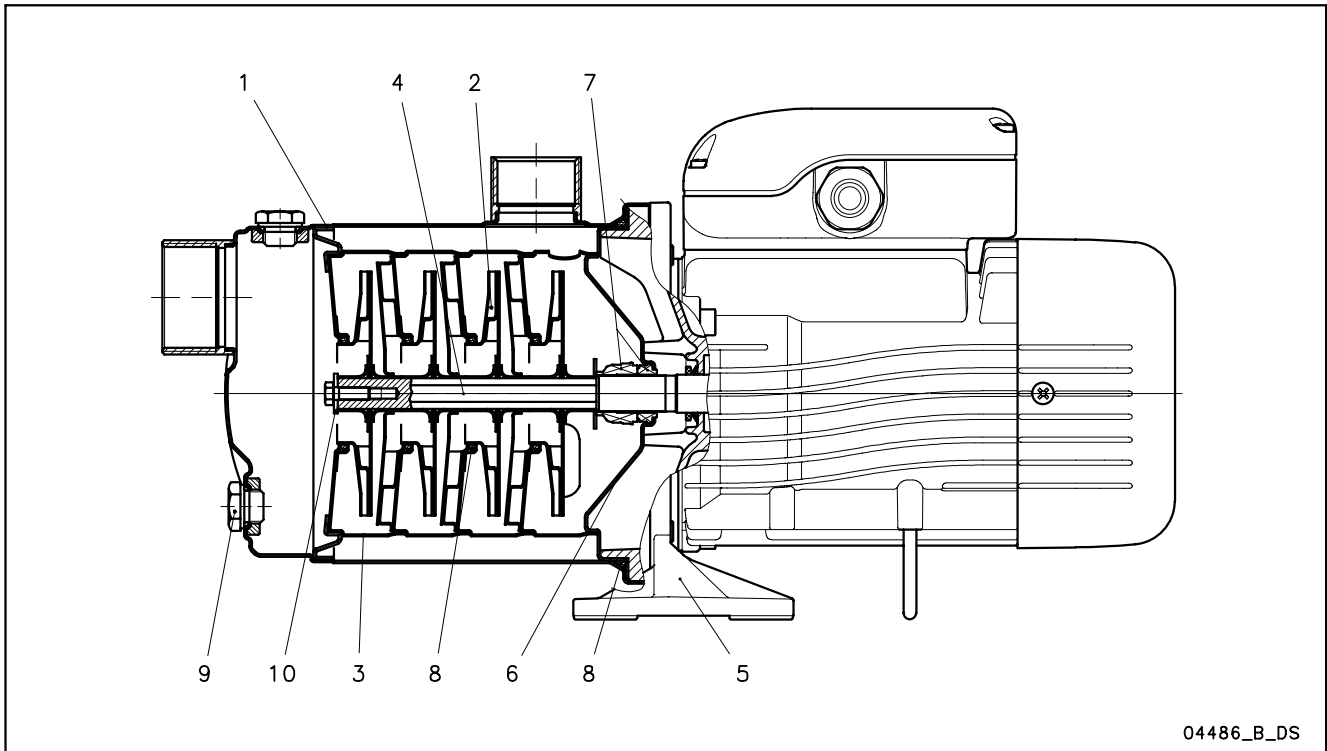

04486\_B\_DS

## HMS SERIES TABLE OF MATERIALS

REF. N.	NAME	MATERIAL	REFERENCE STANDARDS	
			EUROPE	USA
1	Pump body	Stainless steel	EN 10088-1-X2CrNiMo17-12-2 (1.4404)	AISI 316L
2	Impeller	Stainless steel	EN 10088-1-X2CrNiMo17-12-2 (1.4404)	AISI 316L
3	Diffuser	Stainless steel	EN 10088-1-X2CrNiMo17-12-2 (1.4404)	AISI 316L
4	Shaft extension	Stainless steel	EN 10088-1-X5CrNiMo17-12-2 (1.4401)	AISI 316
5	Adapter	Aluminium	EN 1706-AC-AISI11Cu2 (Fe) (AC46100)	-
6	Seal housing	Stainless steel	EN 10088-1-X2CrNiMo17-12-2 (1.4404)	AISI 316L
7	Mechanical seal	Ceramic / Carbon / EPDM (standard version)		
8	Elastomers	EPDM		
9	Fill / drain plugs	Stainless steel	EN 10088-1-X5CrNiMo17-12-2 (1.4401)	AISI 316
10	Bolts and screws	Stainless steel	EN 10088-1-X5CrNiMo17-12-2 (1.4401)	AISI 316

hms-en\_b\_tm



## HM-HMS, MECHANICAL SEAL, ACCORDING TO EN 12756

Mechanical seal with mounting dimensions according to EN12756 (ex DIN 24960) and ISO 3069.

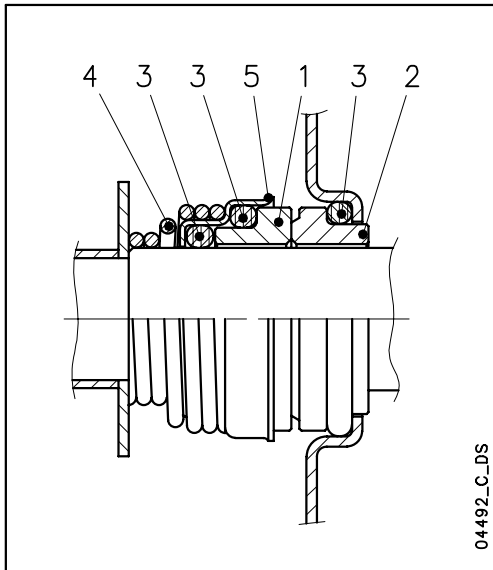

### LIST OF MATERIALS

POSITION 1 - 2	POSITION 3	POSITION 4 - 5
B : Resin impregnated carbon	P : NBR	F : AISI 304
C : Special resin impregnated carbon	E : EPDM	G : AISI 316
Q <sub>1</sub> : Silicon carbide	V : FPM	
U <sub>3</sub> : Tungsten carbide		
V : Ceramic		

hm-ten-mec-en\_a\_tm

### MECHANICAL SEAL TYPES

TYPE	POSITION					TEMPERATURE (°C)
	1 ROTATING ASSEMBLY	2 FIXED ASSEMBLY	3 ELASTOMERS	4 SPRINGS	5 OTHER COMPONENTS	
<b>STANDARD MECHANICAL SEAL</b>						
V B E G G	V	B	E	G	G	-10 +85
<b>OTHER TYPES OF MECHANICAL SEAL</b>						
VCEGG	V	C	E	G	G	-10 +110
Q <sub>1</sub> Q <sub>1</sub> EGG	Q <sub>1</sub>	Q <sub>1</sub>	E	G	G	-10 +110
U <sub>3</sub> CEGG	U <sub>3</sub>	C	E	G	G	-10 +110
U <sub>3</sub> U <sub>3</sub> EGG	U <sub>3</sub>	U <sub>3</sub>	E	G	G	-10 +110
VBVGG	V	B	V	G	G	-10 +110
VCVGG	V	C	V	G	G	-10 +110
Q <sub>1</sub> Q <sub>1</sub> VGG	Q <sub>1</sub>	Q <sub>1</sub>	V	G	G	-10 +110
U <sub>3</sub> CVGG	U <sub>3</sub>	C	V	G	G	-10 +110
U <sub>3</sub> U <sub>3</sub> VGG	U <sub>3</sub>	U <sub>3</sub>	V	G	G	-10 +110

hm-tipi-ten-mec-en\_b\_tc

## COMPATIBILITY CHART FOR MATERIALS IN CONTACT WITH MOST COMMONLY USED LIQUIDS

LIQUID	CONCENTRATION (%)	TEMPERAT. MIN/MAX (°C)	SPECIF. WEIGHT (Kg/dm <sup>3</sup> )	1, 3, 5, 10, 15, 22 SV		33, 46, 66, 92, 125 SV		RECOMMEND. SEAL	ELASTOM.
				VERSION Standard	VERSION N	VERSION Standard	VERSION N		
Acetic acid	80	-10 +70	1,05	•	•		•	Q <sub>1</sub> BEGG	E
Alkaline degreaser	5	80		•	•	•	•	Q <sub>1</sub> Q <sub>1</sub> VGG	V
Aluminium sulfate	30	-5 +50	2,71		•		•	Q <sub>1</sub> Q <sub>1</sub> EGG	E
Ammonia in water	25	-20 +50	0,99	•	•		•	Q <sub>1</sub> BEGG	E
Ammonium sulfate	10	-10 +60	1,77		•		•	Q <sub>1</sub> Q <sub>1</sub> EGG	E
Benzoic acid	70	0 +70	1,31	•	•		•	Q <sub>1</sub> BVGG	V
Boric acid	saturated	-10 +90	1,43	•	•		•	Q <sub>1</sub> Q <sub>1</sub> VGG	V
Butyl alcohol	100	-5 +80	0,81	•	•	•	•	Q <sub>1</sub> BVGG	V
Caustic soda	25	0 +70	2,13	•	•	•	•	Q <sub>1</sub> Q <sub>1</sub> EGG	E
Chloroform	100	-10 +30	1,48	•	•	•	•	Q <sub>1</sub> BVGG	V
Citric acid	5	-10 +70	1,54	•	•		•	Q <sub>1</sub> BEGG	E
Cleaning products	10	-5 +100		•	•	•	•	Q <sub>1</sub> Q <sub>1</sub> VGG	V
Copper sulfate	20	0 +30	2,28		•		•	Q <sub>1</sub> Q <sub>1</sub> VGG	V
Cutting fluid	100	-5 +110	0,90	•	•	•	•	Q <sub>1</sub> BVGG	V
Deionised, demineralised water	100	-25 +110	1	•	•	•	•	Q <sub>1</sub> BEGG	E
Denatured alcohol	100	-5 +70	0,81	•	•	•	•	Q <sub>1</sub> BEGG	E
Diathermic oil	100	-5 +110	0,90	•	•	•	•	Q <sub>1</sub> BVGG	V
Emulsion oil and water	any	-5 +90		•	•	•	•	Q <sub>1</sub> BVGG	V
Ethyl alcohol	100	-5 +40	0,81	•	•	•	•	Q <sub>1</sub> BEGG	E
Ethylene glycol	30	-30 +120			•		•	Q <sub>1</sub> BEGG	E
Formaldehyde	100	0 +30	1,13	•	•	•	•	Q <sub>1</sub> Q <sub>1</sub> TGG	T
Formic acid	5	-15 +25	1,22	•	•		•	Q <sub>1</sub> BEGG	E
Glycerine	100	+20 +90	1,26	•	•	•	•	Q <sub>1</sub> BEGG	E
Hydraulic oil	100	-5 +110		•	•	•	•	Q <sub>1</sub> BVGG	V
Hydrochloric acid	2	-5 +25	1,20		•		•	Q <sub>1</sub> Q <sub>1</sub> VGG	V
Hydroxide sodium	25	0 +70		•	•	•	•	Q <sub>1</sub> Q <sub>1</sub> EGG	E
Iron sulfate	10	-5 +30	2,09		•		•	Q <sub>1</sub> BEGG	E
Methyl alcohol	100	-5 +40	0,79	•	•	•	•	Q <sub>1</sub> BEGG	E
Mineral oil	100	-5 +110	0,94	•	•	•	•	Q <sub>1</sub> BVGG	V
Nitric acid	50	-5 +30	1,48	•	•		•	Q <sub>1</sub> Q <sub>1</sub> VGG	V
Perchloroethylene	100	-10 +30	1,60	•	•	•	•	Q <sub>1</sub> BVGG	V
Phosphates-polyphosphates	10	-5 +90			•		•	Q <sub>1</sub> Q <sub>1</sub> VGG	V
Phosphoric acid	10	-5 +30	1,33		•		•	Q <sub>1</sub> BEGG	E
Propyl alcohol (Propanol)	100	-5 +80	0,80	•	•	•	•	Q <sub>1</sub> BEGG	E
Propylene glycol	30	-30 +120		•	•	•	•	Q <sub>1</sub> BEGG	E
Sodium bicarbonate (Baking soda)	saturated				•		•	Q <sub>1</sub> BEGG	E
Sodium hypochlorite	1	-10 +25			•		•	Q <sub>1</sub> Q <sub>1</sub> VGG	V
Sodium nitrate	saturated	-10 +80	2,25	•	•	•	•	Q <sub>1</sub> BEGG	E
Sodium sulfate	15	-10 +40	2,60	•	•	•	•	Q <sub>1</sub> Q <sub>1</sub> EGG	E
Sulphuric acid	2	-10 +25	1,84		•		•	Q <sub>1</sub> BVGG	V
Tannic acid	20	0 +50			•		•	Q <sub>1</sub> BEGG	E
Tartaric acid	50	-10 +25	1,76	•	•		•	Q <sub>1</sub> Q <sub>1</sub> VGG	V
Trichloroethylene	100	-10 +40	1,46	•	•	•	•	Q <sub>1</sub> BVGG	V
Uric acid	80	-10 +80	1,89	•	•		•	Q <sub>1</sub> BEGG	E
Vegetable oil	100	-5 +110	0,95	•	•	•	•	Q <sub>1</sub> BEGG	E
Water	100	-5 +120		•	•	•	•	Q <sub>1</sub> BEGG	E
Water condensate	100	-5 +100	1	•	•	•	•	Q <sub>1</sub> BEGG	E
Water detergents, mineral oils mixture	10	-5 +80		•	•	•	•	Q <sub>1</sub> Q <sub>1</sub> VGG	V

tab-comp-sv-en\_b\_tm

The above table indicates the compatibility of materials depending on the pumped liquid. Check the specific weight of the liquid or the viscosity as this could affect the power input of the motor and hydraulic performance. For further details, please contact the sales network.

## HM SERIES HYDRAULIC PERFORMANCE TABLE AT 60 Hz, 2 POLES

PUMP TYPE	RATED POWER		Q = DELIVERY										
			l/min	0	20	30	40	50	60	70	80	100	120
	kw	HP	m <sup>3</sup> /h	0	1,2	1,8	2,4	3	3,6	4,2	4,8	6	7,2
H = TOTAL HEAD METERS COLUMN OF WATER													
2HM36(T)	0,3	0,4	23,1	21,0	19,6	17,7	15,3	12,5	9,0				
2HM46(T)	0,45	0,6	35,0	31,5	29,0	26,0	22,4	18,3	13,5				
2HM56(T)	0,55	0,75	45,7	41,1	37,8	33,8	29,0	23,4	17,0				
2HM76(T)	0,75	1	56,8	52,5	48,6	43,6	37,5	30,5	22,5				
4HM46(T)	0,45	0,6	23,6			20,0	18,8	17,5	16,1	14,6	11,3	7,6	
4HM56(T)	0,55	0,75	34,9			29,2	27,4	25,4	23,2	21,0	16,0	10,6	
4HM76(T)	0,75	1	46,5			40,1	37,8	35,3	32,5	29,5	22,8	15,2	
4HM96(T)	0,9	1,2	57,9			50,0	47,3	44,3	41,0	37,4	29,0	19,0	

hm-2p60-en\_b\_th

## HM SERIES ELECTRICAL DATA AT 60 Hz, 2 POLES

PUMP TYPE	MOTOR TYPE	INPUT POWER*	INPUT CURRENT*	CAPACITOR	PUMP TYPE	MOTOR TYPE	INPUT POWER*	INPUT CURRENT*	INPUT CURRENT*
		kw	220-230 V A	µF / 450 V			THREE-PHASE	kw	220-230 V A
2HM36	SM63HM/1036	0,41	2,11	10	2HM36T	SM63HM/303	0,33	1,25	0,72
2HM46	SM63HM/1046	0,59	2,88	14	2HM46T	SM63HM/304	0,53	1,82	1,05
2HM56	SM63HM/1056	0,79	3,80	16	2HM56T	SM63HM/305	0,69	2,22	1,28
2HM76	SM71HM/1076	0,97	4,43	20	2HM76T	SM80HM/307PE	0,85	2,91	1,68
4HM46	SM63HM/1046	0,55	2,76	14	4HM46T	SM63HM/304	0,49	1,75	1,01
4HM56	SM63HM/1056	0,75	3,65	16	4HM56T	SM63HM/305	0,64	2,11	1,22
4HM76	SM71HM/1076	0,98	4,47	20	4HM76T	SM80HM/307PE	0,86	2,93	1,69
4HM96	SM71HM/1076	1,08	4,93	20	4HM96T	SM80HM/307PE	0,97	3,17	1,83

\*Maximum value in specified range

hm-2p60-en\_d\_te

## HMS SERIES HYDRAULIC PERFORMANCE TABLE AT 60 Hz, 2 POLES

PUMP TYPE	RATED POWER		Q = DELIVERY											
			l/min	0	30	40	50	60	70	85	100	120	140	
	HP	m <sup>3</sup> /h	0	1,8	2,4	3	3,6	4,2	5,1	6	7,2	8,4		
kW		H = TOTAL HEAD METERS COLUMN OF WATER												
2HMS36(T)	0,3	0,4	15,8	13,2	12,3	11,2	9,9	8,5	5,7					
2HMS46(T)	0,45	0,6	29,7	24,6	22,5	20,1	17,3	14,3	8,9					
2HMS76(T)	0,75	1	46,5	39,6	36,8	33,6	29,9	25,4	17,2					
2HMS96(T)	0,9	1,2	61,8	52,7	48,9	44,6	39,6	33,6	22,9					
4HMS36(T)	0,3	0,4	14,1			11,6	11,1	10,6	9,8	8,8	7,3	5,4		
4HMS56(T)	0,55	0,75	26,4			21,7	20,7	19,7	18,0	16,0	13,0	9,5		
4HMS96(T)	0,9	1,2	40,3			34,8	33,4	31,8	29,1	26,1	21,4	16,1		

hms-2p60-en\_b\_th

## HMS SERIES ELECTRICAL DATA AT 60 Hz, 2 POLES

PUMP TYPE	MOTOR TYPE	INPUT POWER*	INPUT CURRENT*	CAPACITOR
		kW	220-230 V A	μF / 450 V
SINGLE-PHASE				
2HMS36	SM63HM/1036	0,43	2,15	10
2HMS46	SM63HM/1046	0,65	3,10	14
2HMS76	SM71HM/1076	1,01	4,62	20
2HMS96	SM71HM/1096	1,32	6,01	25
4HMS36	SM63HM/1036	0,48	2,33	10
4HMS56	SM63HM/1056	0,78	3,78	16
4HMS96	SM71HM/1076	1,10	5,04	20

\*Maximum value in specified range

PUMP TYPE	MOTOR TYPE	INPUT POWER*	INPUT CURRENT*	INPUT CURRENT*
		kW	220-230 V A	380-400 V A
THREE-PHASE				
2HMS36T	SM63HM/303	0,35	1,28	0,74
2HMS46T	SM63HM/304	0,60	1,94	1,12
2HMS76T	SM80HM/307PE	0,90	3,01	1,74
2HMS96T	SM80HM/311PE	1,20	4,04	2,33
4HMS36T	SM63HM/303	0,41	1,39	0,80
4HMS56T	SM63HM/305	0,68	2,20	1,27
4HMS96T	SM80HM/307PE	1,00	3,25	1,88

hms-2p60-en\_d\_te

## MOTORS FOR HM-HMS SERIES

**Standard supplied IE2/IE3 three-phase surface motors  $\geq 0,75$  kW are compliant with Regulation (EC) no. 640/2009 and IEC 60034-30.**

Electrical performances according to EN 60034-1.

Insulation class 155 (F). IP55 protection. Condensate drain plugs on standard version.

Cooling by fan according to EN 60034-6.

Cable gland metric size according to EN 50262.

Standard voltage:

- **Single-phase** version: 220-230 V 60 Hz (incorporated automatic-reset overload protection).
- **Three-phase** version : 220 V  $\Delta$ , 380 V Y, 60 Hz (overload protection to be provided by the user).

### SINGLE-PHASE MOTORS AT 60 Hz, 2 POLES

P <sub>N</sub> kW	MOTOR TYPE	IEC SIZE	Construction Design	INPUT CURRENT	CAPACITOR		DATA FOR 220 V 60 Hz VOLTAGE						
				I <sub>n</sub> (A) 220-230 V	$\mu$ F	V	min <sup>-1</sup>	I <sub>s</sub> / I <sub>n</sub>	$\eta$ %	cos $\phi$	T <sub>n</sub> Nm	T <sub>s</sub> /T <sub>n</sub>	T <sub>m</sub> /T <sub>n</sub>
0,3	SM63HM/1036	63	SPECIAL	2,31-2,36	10	450	3350	3,41	62,0	0,95	0,85	0,68	1,88
0,4	SM63HM/1046	63		2,86-2,94	14	450	3385	3,80	67,5	0,94	1,13	0,73	2,04
0,5	SM63HM/1056	63		3,57-3,65	16	450	3365	3,73	66,8	0,95	1,42	0,69	2,07
0,75	SM71HM/1076	71		4,98-4,88	20	450	3380	3,90	69,8	0,98	2,12	0,64	1,91
0,95	SM71HM/1096	71		6,04-5,96	25	450	3370	3,80	72,9	0,98	2,69	0,58	1,86

hm-motm-2p60-en\_a\_te

### THREE-PHASE MOTORS AT 60 Hz, 2 POLES

P <sub>N</sub> kW	Efficiency $\eta_N$ %												Year of construction		
	$\Delta$ 220 V Y 380 V			$\Delta$ 230 V Y 400 V			$\Delta$ 380 V Y 660 V			$\Delta$ 400 V Y 690 V				IE	
	4/4	3/4	2/4	4/4	3/4	2/4	4/4	3/4	2/4	4/4	3/4	2/4			
0,3	-	-	-	-	-	-	-	-	-	-	-	-	-	-	By June 2011
0,4	-	-	-	-	-	-	-	-	-	-	-	-	-	-	
0,5	-	-	-	-	-	-	-	-	-	-	-	-	-	-	
0,75	83,4	82,4	79,0	83,4	82,4	79,0	83,4	82,4	79,0	83,4	82,4	79,0	3		
1,1	85,6	85,0	82,1	85,6	85,0	82,1	85,6	85,0	82,1	85,6	85,0	82,1			

P <sub>N</sub> kW	Manufacturer		IEC SIZE	Construction Design	N. of Poles	f <sub>N</sub> Hz	Data for 380 V / 60 Hz				
	Lowara srl Unipersonale Reg. No. 341820260 Montecchio Maggiore Vicenza - Italia						cos $\phi$	I <sub>s</sub> / I <sub>N</sub>	T <sub>N</sub> Nm	T <sub>s</sub> /T <sub>N</sub>	T <sub>m</sub> /T <sub>N</sub>
	Model										
0,3	SM63HM/303		63	SPECIAL	2	60	0,83	4,17	0,89	2,62	2,27
0,4	SM63HM/304		63				0,81	4,76	1,16	3,48	2,15
0,5	SM63HM/305		63				0,83	4,84	1,46	3,05	1,98
0,75	SM80HM/307PE		80				0,79	8,25	2,05	3,80	4,02
1,1	SM80HM/311PE		80				0,80	9,11	3,01	4,15	4,29

P <sub>N</sub> kW	Voltage U <sub>N</sub> V								$\eta_N$ min <sup>-1</sup>	See note.	Operating conditions **		
	$\Delta$		Y		$\Delta$		Y				Altitude above sea Level (m)	T. amb min/max °C	ATEX
	220 V	230 V	380 V	400 V	380 V	400 V	660 V	690 V					
0,3	1,47	1,45	0,85	0,84	-	-	-	-	3235 ÷ 3280	1000 VI	-15 / 40	No	
0,4	1,96	1,89	1,13	1,09	-	-	-	-	3280 ÷ 3335				
0,5	2,25	2,18	1,30	1,26	-	-	-	-	3260 ÷ 3315				
0,75	3,03	3,01	1,75	1,74	1,75	1,74	1,01	1,00	3490 ÷ 3500				
1,1	4,24	4,24	2,45	2,45	2,44	2,43	1,41	1,40	3490 ÷ 3505				

Note: Observe the regulations and codes locally in force regarding sorted waste disposal.

hm-ie2-mott-2p60-en\_b\_te

\*\* Operating conditions to be referred to motor only. About electric pump, refer to limits in user's manual.

## AVAILABLE VOLTAGES MOTORS FOR HM-HMS SERIES

P <sub>N</sub> kW	IEC SIZE	SINGLE-PHASE							
		50 Hz				60 Hz			
		1 x 220-240	1 x 100	1 x 110-120	1 x 220-230	1 x 100	1 x 110-115	1 x 120-127	1 x 200-210
0,3	63	s	-	-	s	-	o	-	-
0,4	63	s	o	o	s	-	o	-	-
0,5	63	s	-	-	s	-	o	-	-
0,75	71	s	o	o	s	o	o	o	o
0,95	71	s	o	o	s	o	o	o	o

s = Standard voltage      o = Optional voltage

P <sub>N</sub> kW	THREE-PHASE - 2 POLES																		
	50 Hz					60 Hz					50/60 Hz								
	3 x 220-230-240/380-400-415	3 x 380-400-415/660-690	3 x 200-208/346-360	3 x 255-265/440-460	3 x 290-300/500-525	3 x 440-460/-	3 x 500-525/-	3 x 220-230/380-400	3 x 255-265-277/440-460-480	3 x 380-400/660-690	3 x 440-460-480/-	3 x 110-115/190-200	3 x 200-208/346-360	3 x 330-346/575-600	3 x 575/-	3 x 230/400 50 Hz	3 x 265/460 60 Hz	3 x 400/690 50 Hz	3 x 460/- 60 Hz
0,3	s	o	o	o	o	o	o	s	o	o	o	o	o	o	o	o	o	o	o
0,4	s	o	o	o	o	o	o	s	o	o	o	o	o	o	o	o	o	o	o
0,5	s	o	o	o	o	o	o	s	o	o	o	o	o	o	o	o	o	o	o
0,75	s	o	o	o	o	o	o	s	o	o	o	o	o	o	o	o	o	o	o
1,1	s	o	o	o	o	o	o	s	o	o	o	o	o	o	o	o	o	o	o

- = Not available

hm-volt-low-a-en\_a\_te

**HM-HMS SERIES  
HYDRAULIC PERFORMANCE RANGE AT 60 Hz, 2 POLES**

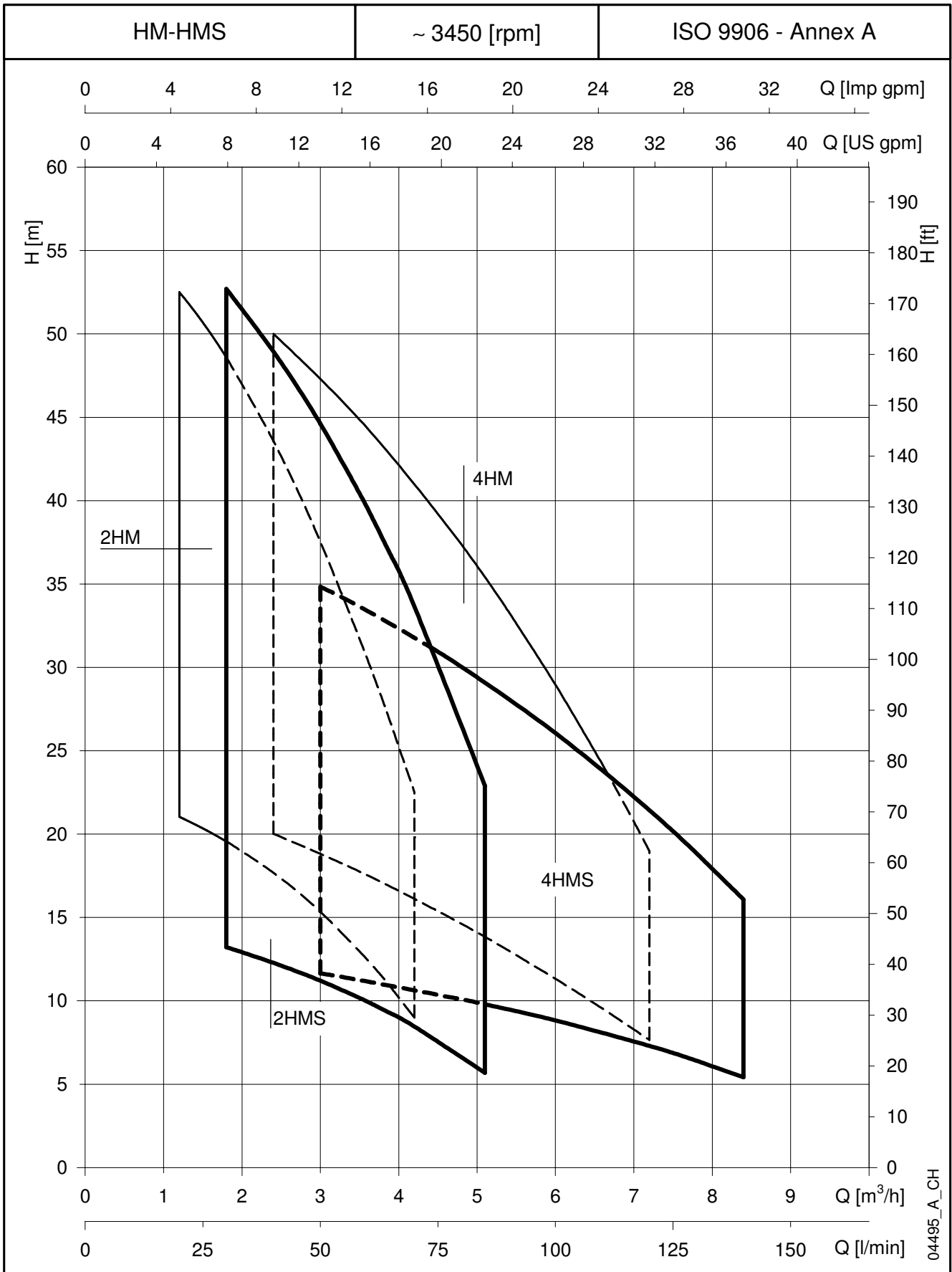

**2HM SERIES  
OPERATING CHARACTERISTICS AT 60 Hz, 2 POLES**

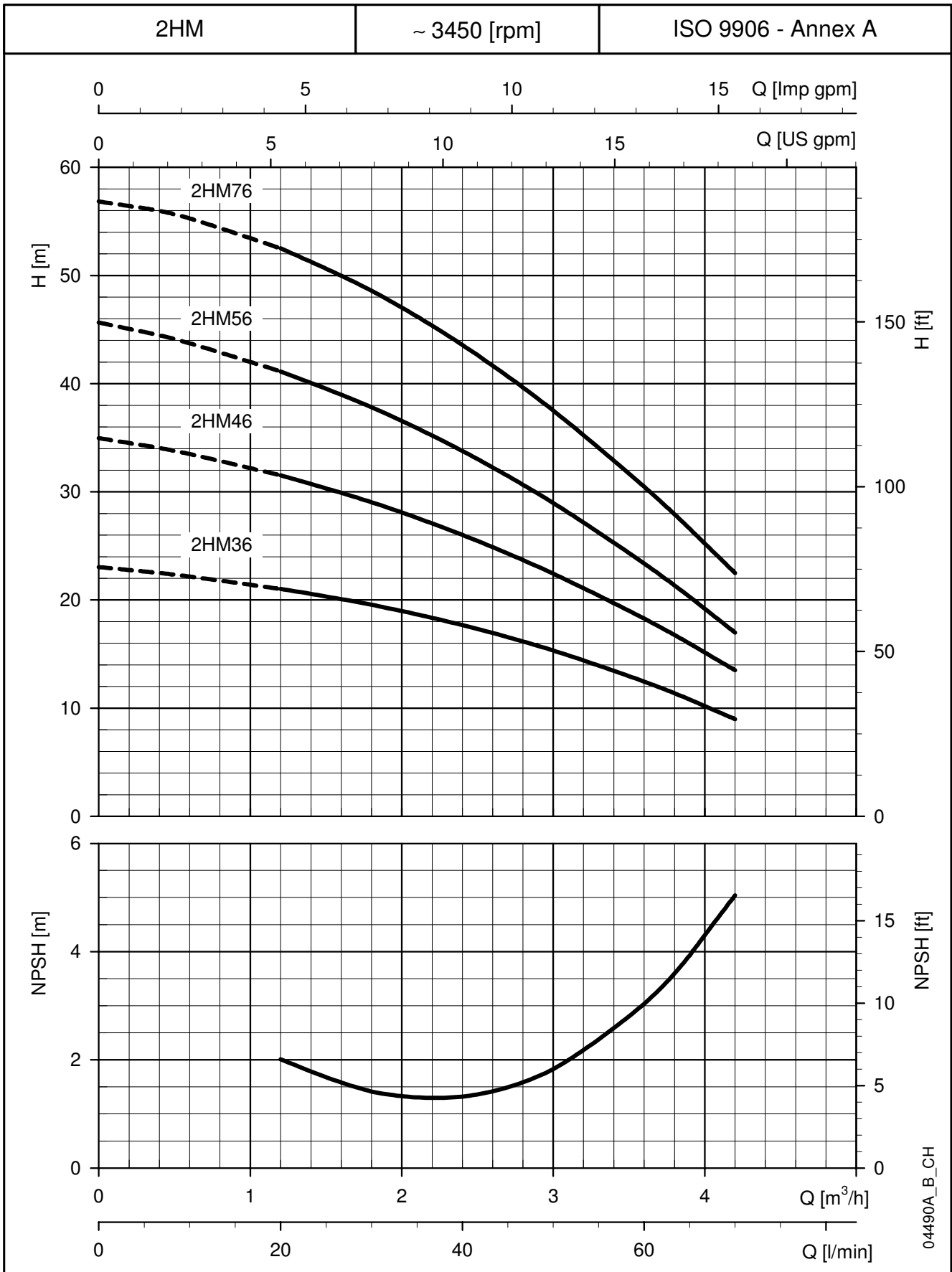

These performances are valid for liquids with density  $\rho = 1.0 \text{ Kg/dm}^3$  and kinematic viscosity  $\nu = 1 \text{ mm}^2/\text{sec}$ .



**4HM SERIES  
OPERATING CHARACTERISTICS AT 60 Hz, 2 POLES**

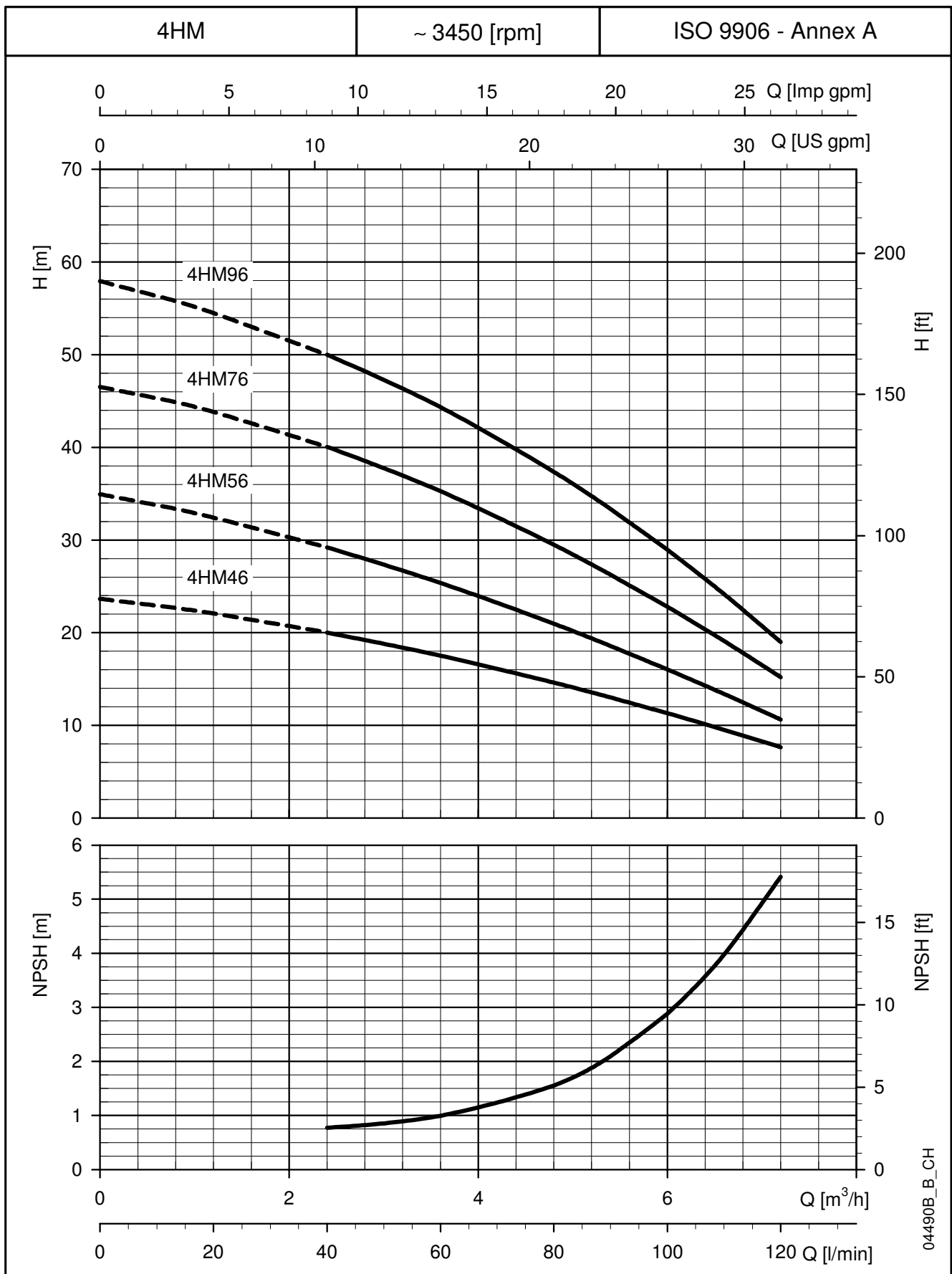

These performances are valid for liquids with density  $\rho = 1.0 \text{ Kg/dm}^3$  and kinematic viscosity  $\nu = 1 \text{ mm}^2/\text{sec}$ .

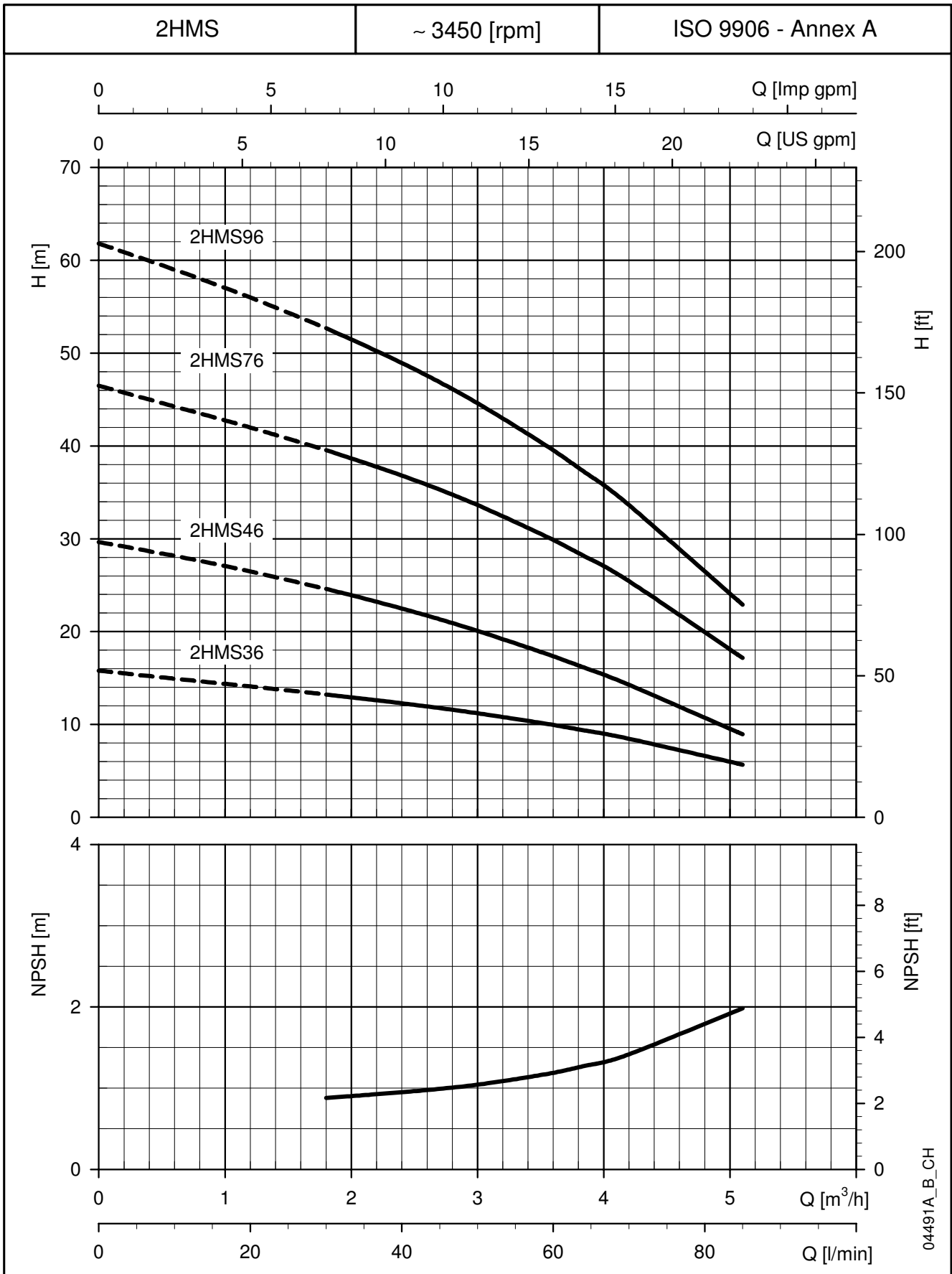
**2HMS SERIES  
OPERATING CHARACTERISTICS AT 60 Hz, 2 POLES**

 These performances are valid for liquids with density  $\rho = 1.0 \text{ Kg/dm}^3$  and kinematic viscosity  $\nu = 1 \text{ mm}^2/\text{sec}$ .

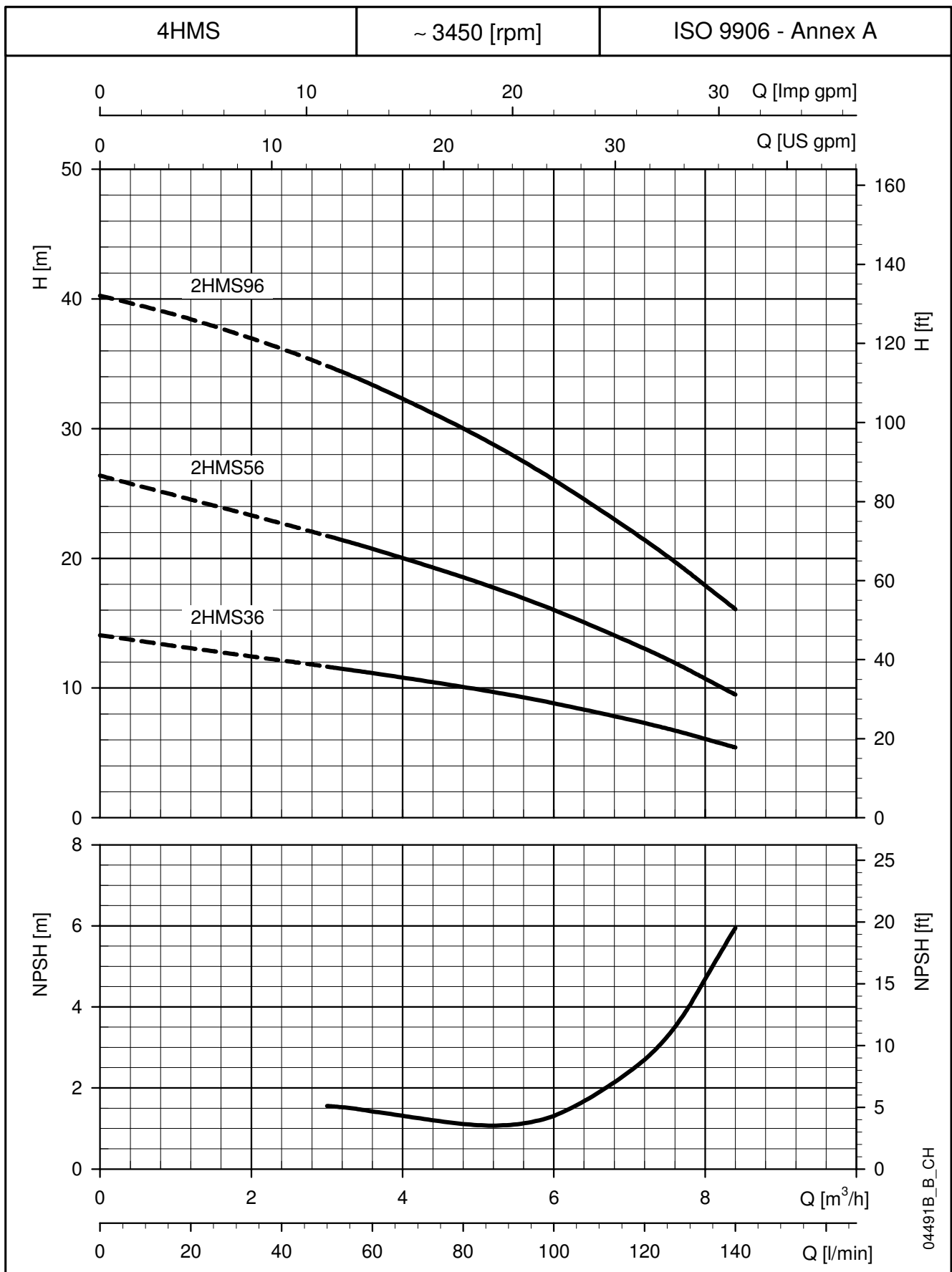
**4HMS SERIES  
OPERATING CHARACTERISTICS AT 60 Hz, 2 POLES**

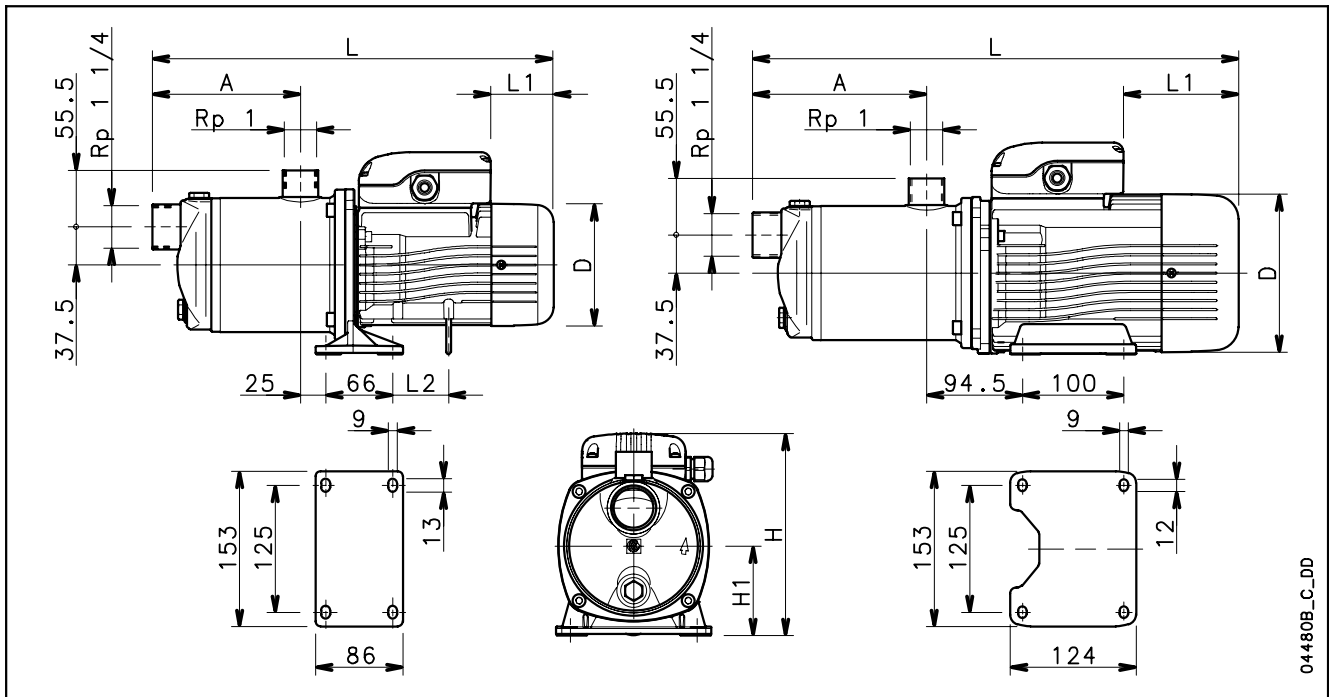

These performances are valid for liquids with density  $\rho = 1.0 \text{ Kg/dm}^3$  and kinematic viscosity  $\nu = 1 \text{ mm}^2/\text{sec}$ .

## HM-HMS SERIES DIMENSIONS AND WEIGHTS AT 60 Hz, 2 POLES



04480B\_C\_DD

PUMP TYPE	DIMENSIONS (mm)						WEIGHT kg
	NUMBER OF STAGES	A	D	L	L1	H	
2HM36/A	2	96	120	345	62	199	6,8
2HM46/A	3	121	120	370	62	199	7,7
2HM56/A	4	146	120	395	62	199	8,5
2HM76/A	5	171	140	434	76	209	12
4HM46/A	2	96	120	345	62	199	7,3
4HM56/A	3	121	120	370	62	199	8,1
4HM76/A	4	146	140	409	31	218	11,6
4HM96/A	5	171	140	434	31	218	11,4
2HM36T/A	2	96	120	345	62	199	6,6
2HM46T/A	3	121	120	370	62	199	7,6
2HM56T/A	4	146	120	395	62	199	8,3
2HM76T/D	5	171	155	480	114	209	13,5
4HM46T/A	2	96	120	345	62	199	7,2
4HM56T/A	3	121	120	370	62	199	8
4HM76T/D	4	146	155	455	114	209	13,5
4HM96T/D	5	171	155	480	114	209	14
2HMS36/A	1	96	120	345	62	199	7
2HMS46/A	2	96	120	345	62	199	7,6
2HMS76/A	3	121	140	384	76	209	12
2HMS96/A	4	146	140	409	76	209	12
4HMS36/A	1	96	120	345	62	199	7
4HMS56/A	2	96	120	345	62	199	8,5
4HMS96/A	3	121	140	384	76	209	10
2HMS36T/A	1	96	120	345	62	199	7
2HMS46T/A	2	96	120	345	62	199	8,2
2HMS76T/D	3	121	155	430	114	209	11
2HMS96T/D	4	146	155	455	114	209	13,5
4HMS36T/A	1	96	120	345	62	199	6,8
4HMS56T/A	2	96	120	345	62	199	8,5
4HMS96T/D	3	121	155	430	114	209	11

hm-hms-2p60-en\_d\_td

# **TECHNICAL APPENDIX**

## **TYPICAL APPLICATIONS HM SERIES ELECTRIC PUMPS**

### ***Water Purification:***

Filtration  
De-ionized water  
Water treatment  
Commercial and residential pools

### ***Plastic Industry:***

Temperature Regulators  
Extrusion machines  
Manufacture of polymers  
Heat treatment

### ***Agricultural Residential Applications:***

Irrigation  
Greenhouses  
Humidifiers  
Water supply

### ***Heating, Ventilating & Air Conditioning:***

Air scrubbers  
Water re-circulation  
Cooling towers  
Cooling systems  
Temperature control  
Chillers  
Induction heating  
Heat exchangers  
Water heating

### ***Waste Management:***

Waste treatment  
Pollution control

### ***Machine Tool:***

Degreasing  
Parts washing  
Chemical treatment

### ***Graphics:***

Film washing  
Cooling processes

### ***Marine Sector:***

Water on board ships

### ***Computers:***

Circuit board washing  
Unit cooling

### ***Laundry:***

Commercial washers

### ***Food and Drink:***

Food processing  
Bottle washing  
Citrus processing  
Dishwashing  
Brewing  
Sanitary ware

### ***General Industry:***

Spray booths  
Light chemical transfer  
Booster systems

### ***Medical:***

Laser cooling  
Massage  
Medical chillers  
Sanitary equipment

## NPSH

The minimum operating values that can be reached at the pump suction end are limited by the onset of cavitation.

Cavitation is the formation of vapour-filled cavities within liquids where the pressure is locally reduced to a critical value, or where the local pressure is equal to, or just below the vapour pressure of the liquid.

The vapour-filled cavities flow with the current and when they reach a higher pressure area the vapour contained in the cavities condenses. The cavities collide, generating pressure waves that are transmitted to the walls. These, being subjected to stress cycles, gradually become deformed and yield due to fatigue. This phenomenon, characterized by a metallic noise produced by the hammering on the pipe walls, is called incipient cavitation.

The damage caused by cavitation may be magnified by electrochemical corrosion and a local rise in temperature due to the plastic deformation of the walls. The materials that offer the highest resistance to heat and corrosion are alloy steels, especially austenitic steel. The conditions that trigger cavitation may be assessed by calculating the total net suction head, referred to in technical literature with the acronym NPSH (Net Positive Suction Head).

The NPSH represents the total energy (expressed in m.) of the liquid measured at suction under conditions of incipient cavitation, excluding the vapour pressure (expressed in m.) that the liquid has at the pump inlet.

To find the static height  $h_z$  at which to install the machine under safe conditions, the following formula must be verified:

$$h_p + h_z \geq (\text{NPSH}_r + 0.5) + h_f + h_{pv} \quad \textcircled{1}$$

where:

- $h_p$**  is the absolute pressure applied to the free liquid surface in the suction tank, expressed in m. of liquid;  $h_p$  is the quotient between the barometric pressure and the specific weight of the liquid.
- $h_z$**  is the suction lift between the pump axis and the free liquid surface in the suction tank, expressed in m.;  $h_z$  is negative when the liquid level is lower than the pump axis.
- $h_f$**  is the flow resistance in the suction line and its accessories, such as: fittings, foot valve, gate valve, elbows, etc.
- $h_{pv}$**  is the vapour pressure of the liquid at the operating temperature, expressed in m. of liquid.  $h_{pv}$  is the quotient between the Pv vapour pressure and the liquid's specific weight.
- 0,5** is the safety factor.

The maximum possible suction head for installation depends on the value of the atmospheric pressure (i.e. the elevation above sea level at which the pump is installed) and the temperature of the liquid.

To help the user, with reference to water temperature (4° C) and to the elevation above sea level, the following tables show the drop in hydraulic pressure head in relation to the elevation above sea level, and the suction loss in relation to temperature.

<b>Water temperature (°C)</b>	20	40	60	80	90	110	120
<b>Suction loss (m)</b>	0,2	0,7	2,0	5,0	7,4	15,4	21,5

<b>Elevation above sea level (m)</b>	500	1000	1500	2000	2500	3000
<b>Suction loss (m)</b>	0,55	1,1	1,65	2,2	2,75	3,3

Friction loss is shown in the tables at pages 25-26 of this catalogue. To reduce it to a minimum, especially in cases of high suction head (over 4-5 m.) or within the operating limits with high flow rates, we recommend using a suction line having a larger diameter than that of the pump's suction port. It is always a good idea to position the pump as close as possible to the liquid to be pumped.

Make the following calculation:

Liquid: water at ~15°C  $\gamma = 1 \text{ kg/dm}^3$

Flow rate required: 30 m<sup>3</sup>/h

Head for required delivery: 43 m.

Suction lift: 3,5 m.

The selection is an FHE 40-200/75 pump whose NPSH required value is, at 30 m<sup>3</sup>/h, di 2,5 m.

For water at 15 °C

$$h_p = P_a / \gamma = 10,33\text{m}, h_{pv} = P_v / \gamma = 0,174\text{m} (0,01701 \text{ bar})$$

The  $H_f$  flow resistance in the suction line with foot valves is ~ 1,2 m.

By substituting the parameters in formula  $\textcircled{1}$  with the numeric values above, we have:

$$10,33 + (-3,5) \geq (2,5 + 0,5) + 1,2 + 0,17$$

from which we have: 6,8 > 4,4

The relation is therefore verified.

## TECHNICAL APPENDIX VAPOUR PRESSURE PS VAPOUR PRESSURE AND $\rho$ DENSITY OF WATER TABLE

t °C	T K	ps bar	$\rho$ kg/dm <sup>3</sup>	t °C	T K	ps bar	$\rho$ kg/dm <sup>3</sup>	t °C	T K	ps bar	$\rho$ kg/dm <sup>3</sup>
0	273,15	0,00611	0,9998	55	328,15	0,15741	0,9857	120	393,15	1,9854	0,9429
1	274,15	0,00657	0,9999	56	329,15	0,16511	0,9852	122	395,15	2,1145	0,9412
2	275,15	0,00706	0,9999	57	330,15	0,17313	0,9846	124	397,15	2,2504	0,9396
3	276,15	0,00758	0,9999	58	331,15	0,18147	0,9842	126	399,15	2,3933	0,9379
4	277,15	0,00813	1,0000	59	332,15	0,19016	0,9837	128	401,15	2,5435	0,9362
5	278,15	0,00872	1,0000	60	333,15	0,1992	0,9832	130	403,15	2,7013	0,9346
6	279,15	0,00935	1,0000	61	334,15	0,2086	0,9826	132	405,15	2,867	0,9328
7	280,15	0,01001	0,9999	62	335,15	0,2184	0,9821	134	407,15	3,041	0,9311
8	281,15	0,01072	0,9999	63	336,15	0,2286	0,9816	136	409,15	3,223	0,9294
9	282,15	0,01147	0,9998	64	337,15	0,2391	0,9811	138	411,15	3,414	0,9276
10	283,15	0,01227	0,9997	65	338,15	0,2501	0,9805	140	413,15	3,614	0,9258
11	284,15	0,01312	0,9997	66	339,15	0,2615	0,9799	145	418,15	4,155	0,9214
12	285,15	0,01401	0,9996	67	340,15	0,2733	0,9793	155	428,15	5,433	0,9121
13	286,15	0,01497	0,9994	68	341,15	0,2856	0,9788	160	433,15	6,181	0,9073
14	287,15	0,01597	0,9993	69	342,15	0,2984	0,9782	165	438,15	7,008	0,9024
15	288,15	0,01704	0,9992	70	343,15	0,3116	0,9777	170	443,15	7,920	0,8973
16	289,15	0,01817	0,9990	71	344,15	0,3253	0,9770	175	448,15	8,924	0,8921
17	290,15	0,01936	0,9988	72	345,15	0,3396	0,9765	180	453,15	10,027	0,8869
18	291,15	0,02062	0,9987	73	346,15	0,3543	0,9760	185	458,15	11,233	0,8815
19	292,15	0,02196	0,9985	74	347,15	0,3696	0,9753	190	463,15	12,551	0,8760
20	293,15	0,02337	0,9983	75	348,15	0,3855	0,9748	195	468,15	13,987	0,8704
21	294,15	0,24850	0,9981	76	349,15	0,4019	0,9741	200	473,15	15,550	0,8647
22	295,15	0,02642	0,9978	77	350,15	0,4189	0,9735	205	478,15	17,243	0,8588
23	296,15	0,02808	0,9976	78	351,15	0,4365	0,9729	210	483,15	19,077	0,8528
24	297,15	0,02982	0,9974	79	352,15	0,4547	0,9723	215	488,15	21,060	0,8467
25	298,15	0,03166	0,9971	80	353,15	0,4736	0,9716	220	493,15	23,198	0,8403
26	299,15	0,03360	0,9968	81	354,15	0,4931	0,9710	225	498,15	25,501	0,8339
27	300,15	0,03564	0,9966	82	355,15	0,5133	0,9704	230	503,15	27,976	0,8273
28	301,15	0,03778	0,9963	83	356,15	0,5342	0,9697	235	508,15	30,632	0,8205
29	302,15	0,04004	0,9960	84	357,15	0,5557	0,9691	240	513,15	33,478	0,8136
30	303,15	0,04241	0,9957	85	358,15	0,5780	0,9684	245	518,15	36,523	0,8065
31	304,15	0,04491	0,9954	86	359,15	0,6011	0,9678	250	523,15	39,776	0,7992
32	305,15	0,04753	0,9951	87	360,15	0,6249	0,9671	255	528,15	43,246	0,7916
33	306,15	0,05029	0,9947	88	361,15	0,6495	0,9665	260	533,15	46,943	0,7839
34	307,15	0,05318	0,9944	89	362,15	0,6749	0,9658	265	538,15	50,877	0,7759
35	308,15	0,05622	0,9940	90	363,15	0,7011	0,9652	270	543,15	55,058	0,7678
36	309,15	0,05940	0,9937	91	364,15	0,7281	0,9644	275	548,15	59,496	0,7593
37	310,15	0,06274	0,9933	92	365,15	0,7561	0,9638	280	553,15	64,202	0,7505
38	311,15	0,06624	0,9930	93	366,15	0,7849	0,9630	285	558,15	69,186	0,7415
39	312,15	0,06991	0,9927	94	367,15	0,8146	0,9624	290	563,15	74,461	0,7321
40	313,15	0,07375	0,9923	95	368,15	0,8453	0,9616	295	568,15	80,037	0,7223
41	314,15	0,07777	0,9919	96	369,15	0,8769	0,9610	300	573,15	85,927	0,7122
42	315,15	0,08198	0,9915	97	370,15	0,9094	0,9602	305	578,15	92,144	0,7017
43	316,15	0,09639	0,9911	98	371,15	0,9430	0,9596	310	583,15	98,70	0,6906
44	317,15	0,09100	0,9907	99	372,15	0,9776	0,9586	315	588,15	105,61	0,6791
45	318,15	0,09582	0,9902	100	373,15	1,0133	0,9581	320	593,15	112,89	0,6669
46	319,15	0,10086	0,9898	102	375,15	1,0878	0,9567	325	598,15	120,56	0,6541
47	320,15	0,10612	0,9894	104	377,15	1,1668	0,9552	330	603,15	128,63	0,6404
48	321,15	0,11162	0,9889	106	379,15	1,2504	0,9537	340	613,15	146,05	0,6102
49	322,15	0,11736	0,9884	108	381,15	1,3390	0,9522	350	623,15	165,35	0,5743
50	323,15	0,12335	0,9880	110	383,15	1,4327	0,9507	360	633,15	186,75	0,5275
51	324,15	0,12961	0,9876	112	385,15	1,5316	0,9491	370	643,15	210,54	0,4518
52	325,15	0,13613	0,9871	114	387,15	1,6362	0,9476	374,15	647,30	221,20	0,3154
53	326,15	0,14293	0,9862	116	389,15	1,7465	0,9460				
54	327,15	0,15002	0,9862	118	391,15	1,8628	0,9445				

G-at\_nps\_h\_a\_sc



**TABLE OF FLOW RESISTANCE IN 100 m OF STRAIGHT CAST IRON PIPELINE (HAZEN-WILLIAMS FORMULA C=100)**

FLOW RATE		NOMINAL DIAMETER in mm and INCHES																											
m <sup>3</sup> /h	l/min	15	20	25	32	40	50	65	80	100	125	150	175	200	250	300	350	400											
		1/2"	3/4"	1"	1 1/4"	1 1/2"	2	2 1/2"	3"	4"	5"	6"	7"	8"	10"	12"	14"	16"											
0,6	10	v	0,94	0,53	0,34	0,21	0,13	The hr values must be multiplied by: 0.71 for galvanized or painted steel pipes 0.54 for stainless steel or copper pipes 0.47 for PVC or PE pipes																					
		hr	16	3,94	1,33	0,40	0,13																						
0,9	15	v	1,42	0,80	0,51	0,31	0,20																						
		hr	33,9	8,35	2,82	0,85	0,29																						
1,2	20	v	1,89	1,06	0,68	0,41	0,27	0,17																					
		hr	57,7	14,21	4,79	1,44	0,49	0,16																					
1,5	25	v	2,36	1,33	0,85	0,52	0,33	0,21																					
		hr	87,2	21,5	7,24	2,18	0,73	0,25																					
1,8	30	v	2,83	1,59	1,02	0,62	0,40	0,25																					
		hr	122	30,1	10,1	3,05	1,03	0,35																					
2,1	35	v	3,30	1,86	1,19	0,73	0,46	0,30																					
		hr	162	40,0	13,5	4,06	1,37	0,46																					
2,4	40	v		2,12	1,36	0,83	0,53	0,34	0,20																				
		hr		51,2	17,3	5,19	1,75	0,59	0,16																				
3	50	v		2,65	1,70	1,04	0,66	0,42	0,25																				
		hr		77,4	26,1	7,85	2,65	0,89	0,25																				
3,6	60	v		3,18	2,04	1,24	0,80	0,51	0,30																				
		hr		108	36,6	11,0	3,71	1,25	0,35																				
4,2	70	v		3,72	2,38	1,45	0,93	0,59	0,35																				
		hr		144	48,7	14,6	4,93	1,66	0,46																				
4,8	80	v		4,25	2,72	1,66	1,06	0,68	0,40																				
		hr		185	62,3	18,7	6,32	2,13	0,59																				
5,4	90	v			3,06	1,87	1,19	0,76	0,45												0,30								
		hr			77,5	23,3	7,85	2,65	0,74	0,27																			
6	100	v			3,40	2,07	1,33	0,85	0,50	0,33																			
		hr			94,1	28,3	9,54	3,22	0,90	0,33																			
7,5	125	v			4,25	2,59	1,66	1,06	0,63	0,41																			
		hr			142	42,8	14,4	4,86	1,36	0,49																			
9	150	v				3,11	1,99	1,27	0,75	0,50	0,32																		
		hr				59,9	20,2	6,82	1,90	0,69	0,23																		
10,5	175	v				3,63	2,32	1,49	0,88	0,58	0,37																		
		hr				79,7	26,9	9,07	2,53	0,92	0,31																		
12	200	v				4,15	2,65	1,70	1,01	0,66	0,42																		
		hr				102	34,4	11,6	3,23	1,18	0,40																		
15	250	v				5,18	3,32	2,12	1,26	0,83	0,53												0,34						
		hr				154	52,0	17,5	4,89	1,78	0,60	0,20																	
18	300	v					3,98	2,55	1,51	1,00	0,64	0,41																	
		hr					72,8	24,6	6,85	2,49	0,84	0,28																	
24	400	v					5,31	3,40	2,01	1,33	0,85	0,54												0,38					
		hr					124	41,8	11,66	4,24	1,43	0,48	0,20																
30	500	v					6,63	4,25	2,51	1,66	1,06	0,68	0,47																
		hr					187	63,2	17,6	6,41	2,16	0,73	0,30																
36	600	v					5,10	3,02	1,99	1,27	0,82	0,57	0,42																
		hr					88,6	24,7	8,98	3,03	1,02	0,42	0,20																
42	700	v					5,94	3,52	2,32	1,49	0,95	0,66	0,49																
		hr					118	32,8	11,9	4,03	1,36	0,56	0,26																
48	800	v					6,79	4,02	2,65	1,70	1,09	0,75	0,55																
		hr					151	42,0	15,3	5,16	1,74	0,72	0,34																
54	900	v					7,64	4,52	2,99	1,91	1,22	0,85	0,62																
		hr					188	52,3	19,0	6,41	2,16	0,89	0,42																
60	1000	v					5,03	3,32	2,12	1,36	0,94	0,69	0,53																
		hr					63,5	23,1	7,79	2,63	1,08	0,51	0,27																
75	1250	v					6,28	4,15	2,65	1,70	1,18	0,87	0,66																
		hr					96,0	34,9	11,8	3,97	1,63	0,77	0,40																
90	1500	v					7,54	4,98	3,18	2,04	1,42	1,04	0,80																
		hr					134	48,9	16,5	5,57	2,29	1,08	0,56																
105	1750	v					8,79	5,81	3,72	2,38	1,65	1,21	0,93																
		hr					179	65,1	21,9	7,40	3,05	1,44	0,75																
120	2000	v					6,63	4,25	2,72	1,89	1,39	1,06	0,68																
		hr					83,3	28,1	9,48	3,90	1,84	0,96	0,32																
150	2500	v					8,29	5,31	3,40	2,36	1,73	1,33	0,85																
		hr					126	42,5	14,3	5,89	2,78	1,45	0,49																
180	3000	v								6,37	4,08	2,83	2,08												1,59	1,02	0,71		
		hr								59,5	20,1	8,26	3,90	2,03	0,69	0,28													
210	3500	v								7,43	4,76	3,30	2,43	1,86	1,19	0,83													
		hr								79,1	26,7	11,0	5,18	2,71	0,91	0,38													
240	4000	v								8,49	5,44	3,77	2,77	2,12	1,36	0,94													
		hr								101	34,2	14,1	6,64	3,46	1,17	0,48													
300	5000	v									6,79	4,72	3,47	2,65	1,70	1,18													
		hr									51,6	21,2	10,0	5,23	1,77	0,73													
360	6000	v									8,15	5,66	4,16	3,18	2,04	1,42													
		hr									72,3	29,8	14,1	7,33	2,47	1,02													
420	7000	v										6,61	4,85	3,72	2,38	1,65												1,21	
		hr										39,6	18,7	9,75	3,29	1,35	0,64												
480	8000	v										7,55	5,55	4,25	2,72	1,89	1,39												
		hr										50,7	23,9	12,49	4,21	1,73	0,82												
540	9000	v										8,49	6,24	4,78	3,06	2,12	1,56												1,19
		hr										63,0	29,8	15,5	5,24	2,16	1,02	0,53											
600	10000	v											6,93	5,31	3,40	2,36	1,73	1,33											
		hr											36,2	18,9	6,36	2,62	1,24	0,65											

G-at-pct\_a\_th

hr = flow resistance for 100m of straight pipeline (m)  
V = water speed (m/s)

## FLOW RESISTANCE

### TABLE OF FLOW RESISTANCE IN BENDS, VALVES AND GATES

The flow resistance is calculated using the equivalent pipeline length method according to the table below:

ACCESSORY TYPE	DN											
	25	32	40	50	65	80	100	125	150	200	250	300
	Equivalent pipeline length (m)											
45° bend	0,2	0,2	0,4	0,4	0,6	0,6	0,9	1,1	1,5	1,9	2,4	2,8
90° bend	0,4	0,6	0,9	1,1	1,3	1,5	2,1	2,6	3,0	3,9	4,7	5,8
90° smooth bend	0,4	0,4	0,4	0,6	0,9	1,1	1,3	1,7	1,9	2,8	3,4	3,9
Union tee or cross	1,1	1,3	1,7	2,1	2,6	3,2	4,3	5,3	6,4	7,5	10,7	12,8
Gate	-	-	-	0,2	0,2	0,2	0,4	0,4	0,6	0,9	1,1	1,3
Non return valve	1,1	1,5	1,9	2,4	3,0	3,4	4,7	5,9	7,4	9,6	11,8	13,9

G-a-pcv\_a\_th

The table is valid for the Hazen Williams coefficient  $C = 100$  (cast iron pipework). For steel pipework, multiply the values by 1.41. For stainless steel, copper and coated cast iron pipework, multiply the values by 1.85.

When the **equivalent pipeline length** has been determined, the flow resistance is obtained from the table of flow resistance.

The values given are guideline values which are bound to vary slightly according to the model, especially for gate valves and non-return valves, for which it is a good idea to check the values supplied by the manufacturers.

## VOLUMETRIC CAPACITY

Litres per minute l/min	Cubic metres per hour m <sup>3</sup> /h	Cubic feet per hour ft <sup>3</sup> /h	Cubic feet per minute ft <sup>3</sup> /min	Imp. gal. per minute Imp. gal./min	US gal. per minute Us gal./min
<b>1,000</b>	0,0600	2,1189	0,0353	0,2200	0,2642
16,6667	<b>1,000</b>	35,3147	0,5886	3,6662	4,4029
0,4719	0,0283	<b>1,000</b>	0,0167	0,1038	<b>0,1247</b>
28,3168	1,6990	60,0000	<b>1,000</b>	6,2288	7,4805
4,5461	0,2728	9,6326	0,1605	<b>1,000</b>	1,2009
3,7854	0,2271	8,0208	0,1337	0,8327	<b>1,000</b>

## PRESSURE AND HEAD

Newton per square metre N/m <sup>2</sup>	kilo Pascal kPa	bar bar	Pound force per square inch psi	metre of water m H <sub>2</sub> O	millimetre of mercury mm Hg
<b>1,000</b>	0,0010	1 x 10 <sup>-5</sup>	1.45 x 10 <sup>-4</sup>	1.02 x 10 <sup>-4</sup>	0,0075
1000,0000	<b>1,000</b>	0,0100	0,1450	0,1020	7,5006
1 x 10 <sup>5</sup>	100,0000	<b>1,000</b>	14,5038	10,1972	750,0638
6894,7570	6,8948	0,0689	<b>1,000</b>	0,7031	51,7151
9806,6500	9,8067	0,0981	1,4223	<b>1,000</b>	73,5561
133,3220	0,1333	0,0013	0,0193	0,0136	<b>1,000</b>

## LENGTH

millimetre mm	centimetre cm	metre m	inch in	foot ft	yard yd
<b>1,000</b>	0,1000	0,0010	0,0394	0,0033	0,0011
10,0000	<b>1,000</b>	0,0100	0,3937	0,0328	0,0109
1000,0000	100,0000	<b>1,000</b>	39,3701	3,2808	1,0936
25,4000	2,5400	0,0254	<b>1,000</b>	0,0833	0,0278
304,8000	30,4800	0,3048	12,0000	<b>1,000</b>	0,3333
914,4000	91,4400	0,9144	36,0000	3,0000	<b>1,000</b>

## VOLUME

cubic metre m <sup>3</sup>	litre litro	millilitre ml	imp. Gallon imp. gal.	US gallon US gal.	cubic foot ft <sup>3</sup>
<b>1,000</b>	1000,0000	1 x 10 <sup>6</sup>	219,9694	264,1720	35,3147
0,0010	<b>1,000</b>	1000,0000	0,2200	0,2642	0,0353
1 x 10 <sup>-6</sup>	0,0010	<b>1,000</b>	2.2 x 10 <sup>-4</sup>	2.642 x 10 <sup>-4</sup>	3.53 x 10 <sup>-5</sup>
0,0045	4,5461	4546,0870	<b>1,000</b>	1,2009	0,1605
0,0038	3,7854	3785,4120	0,8327	<b>1,000</b>	0,1337
0,0283	28,3168	28316,8466	6,2288	7,4805	<b>1,000</b>

G-at\_pp-en\_a\_sc

## FURTHER PRODUCT SELECTION AND DOCUMENTATION

### Xylect

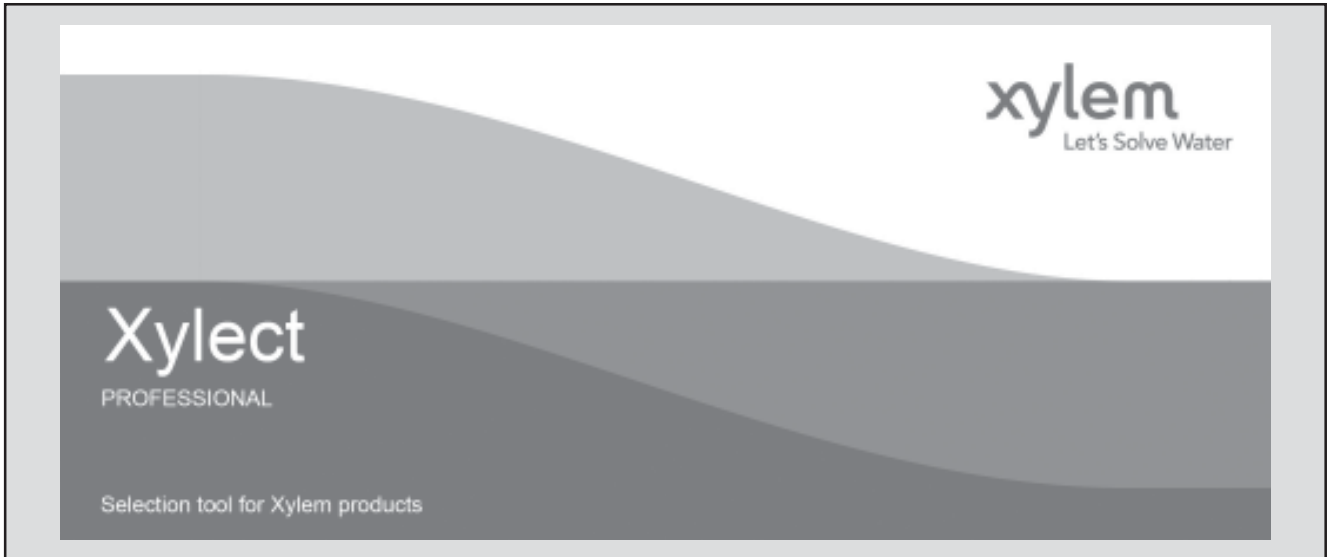

Xylect is pump solution selection software with an extensive online database of product information across the entire Lowara, and Vogel range of pumps and related products, with multiple search options and helpful project management facilities. The system holds up-to-date product information on thousands of products and accessories.

The possibility to search by applications and the detailed information output given makes it easy to make the optimal selection without having detailed knowledge about the Lowara and Vogel products.

The search can be made by:

- Application
- Product type
- Duty point

Xylect gives a detailed output:

- List with search results
- Performance curves (flow, head, power, efficiency, NPSH)
- Motor data
- Dimensional drawings
- Options
- Data sheet printouts
- Document downloads incl dxf files

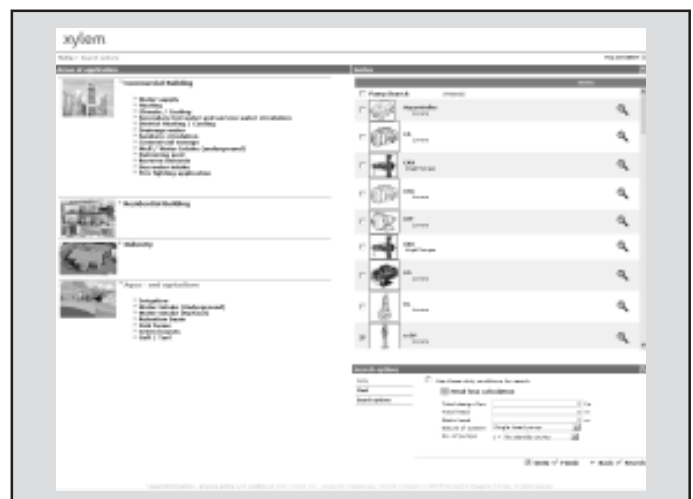

*The search by application guides users not familiar with the product range to the right choice.*

**FURTHER PRODUCT SELECTION AND DOCUMENTATION**

**Xylect**

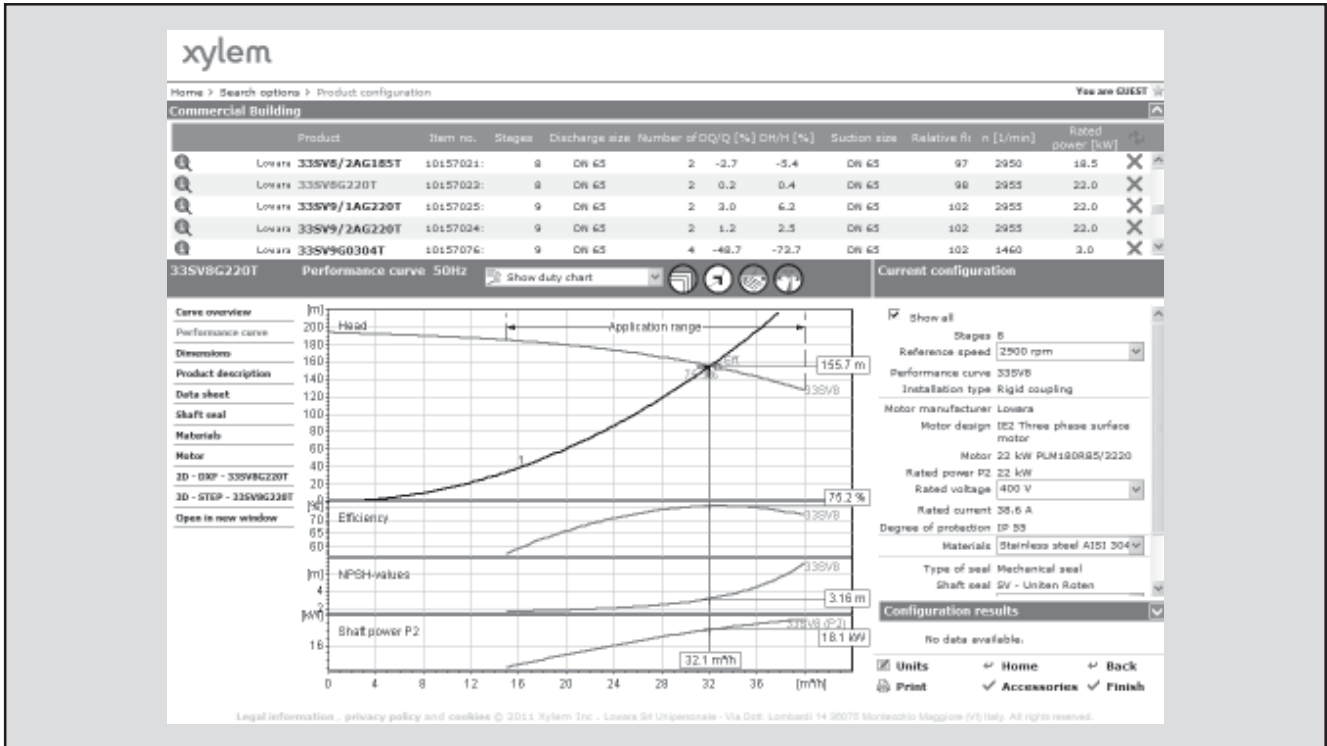

The detailed output makes it easy to select the optimal pump from the given alternatives.

The best way to work with Xylect is to create a personal account. This makes it possible to:

- Set own standard units
- Create and save projects
- Share projects with other Xylect users

Every user has a My Xylect space, where all projects are saved.

For more information about Xylect please contact our sales network or visit [www.xylect.com](http://www.xylect.com).

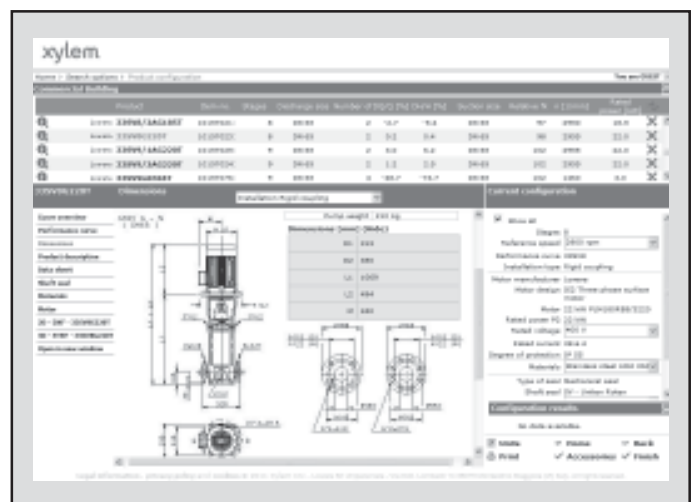

Dimensional drawings appear on the screen and can be downloaded in dxf format.

---

---

---

---

---

---

---

---

---

---

---

---

---

---

---

---

---

---

---

---

---

---

---

---

---

---

---

---

---

---



# Xylem |'zīləm|

- 1) The tissue in plants that brings water upward from the roots;
- 2) a leading global water technology company.

We're 12,000 people unified in a common purpose: creating innovative solutions to meet our world's water needs. Developing new technologies that will improve the way water is used, conserved, and re-used in the future is central to our work. We move, treat, analyze, and return water to the environment, and we help people use water efficiently, in their homes, buildings, factories and farms. In more than 150 countries, we have strong, long-standing relationships with customers who know us for our powerful combination of leading product brands and applications expertise, backed by a legacy of innovation.

**For more information on how Xylem can help you, go to [xylem.com](http://xylem.com).**



Headquarters

LOWARA S.r.l. Unipersonale  
Via Vittorio Lombardi 14  
36075 Montecchio Maggiore - Vicenza - Italy  
Tel. (+39) 0444 707111 - Fax (+39) 0444 492166  
e-mail: [lowara.mkt@xylem.com](mailto:lowara.mkt@xylem.com)  
web: [www.lowara.com](http://www.lowara.com) - [www.completewatersystems.com](http://www.completewatersystems.com)

LOWARA reserves the right to make modification without prior notice.  
LOWARA is a trademark of Xylem Inc. or one of its subsidiaries.