



# System connection with Mixing Modules

CONTROL STATIONS WITH INTEGRATED CIRCULATION PUMP FOR PROFESSIONAL CONNECTION OF SURFACE HEATING SYSTEMS UP TO 200 M<sup>2</sup>, ALSO IDEAL FOR FLOOR HEATING RETROFITTING

# Mixing Modules. System benefits

## System comparison.

Left: conventional solution with two loops through the whole building from the boiler to the surface heating manifolds in the living area and with an additional mixing module on the boiler.

Right: BM system connection without second loop and without mixing module on the boiler.

Direct installation in the living area guarantees more comfort by individual adjustment of each station. Expensive reconstruction work for a second loop through the whole building (for example when retrofitting) can be avoided.

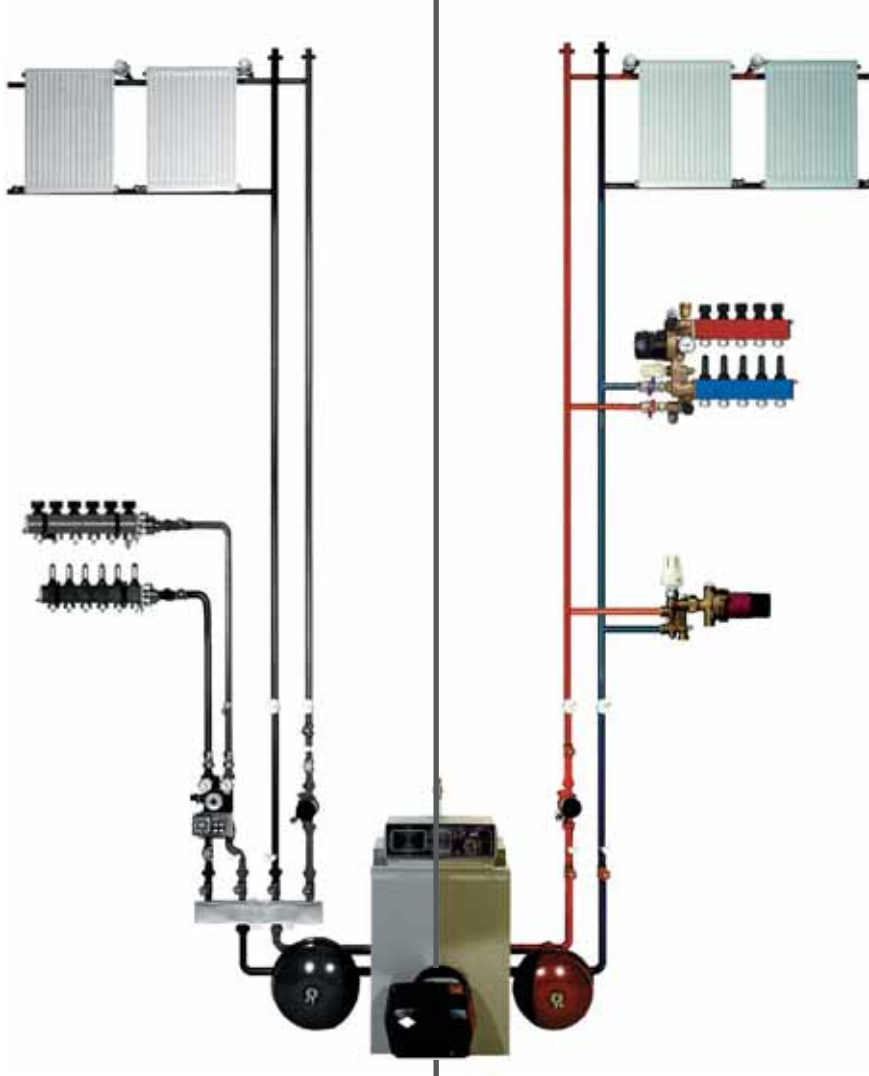

# Comparison between a conventional solution for the connection of a surface heating system and a complete BM system connection without a second loop.

## Design principle.

By using a system connection with BM mixing modules the high supply temperature of the radiator circuit (e.g. 70°C) is reduced directly in the living area to the lower temperature level (e.g. 45°C) required by the surface heating.

The complete absence of an expensive second low temperature piping network from the boiler to the floor heating manifold results in substantial cost benefits. In addition to this second loop, it is also possible to dispense with the boiler manifold and the mixer for the floor circuit. Therefore the system is ideal for refurbishments, as reconstruction work is significantly reduced.

## Application.

The mixing module BM mini is recommended for small areas and individual rooms.

Regulating the primary feed gives a pleasant and even heat distribution. For larger surfaces up to 200 m<sup>2</sup> the BM eco mixer can also be installed directly in the living area. The system for BM mixers is conceived for oxygen tight surface heating systems.



### BM mini mixing module.

Mixing module for individual rooms and small surfaces, transmission capacity approx. 3 kW, for heating surfaces depending on layout up to approx. 40 m<sup>2</sup> very compact.

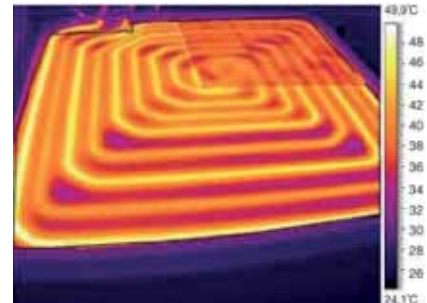

A look through a thermal camera shows the even heat distribution of a small heating floor surface with the BM mini

## Benefits.

Mixing directly in the apartment enables individual adjustment of the surface heating. Each apartment can be controlled depending on the floor covering as well as according to individual and timing requirements. Every apartment owner can set their own optimum heating comfort. As no low temperature loop is required, a floor heating system can also be installed in individual apartments or rooms in single or multiple-family dwellings. The conversion requires only limited space, thus giving new opportunities for the retrofitting of a floor heating system.



### BM eco mixing module.

Mixing module for apartments or individual floor levels, transmission capacity approx. 15 kW, for heating surfaces depending on layout up to approx. 200 m<sup>2</sup>, with mixer module and high efficiency circulation pump with energy efficiency class A.

# BM mini mixing module

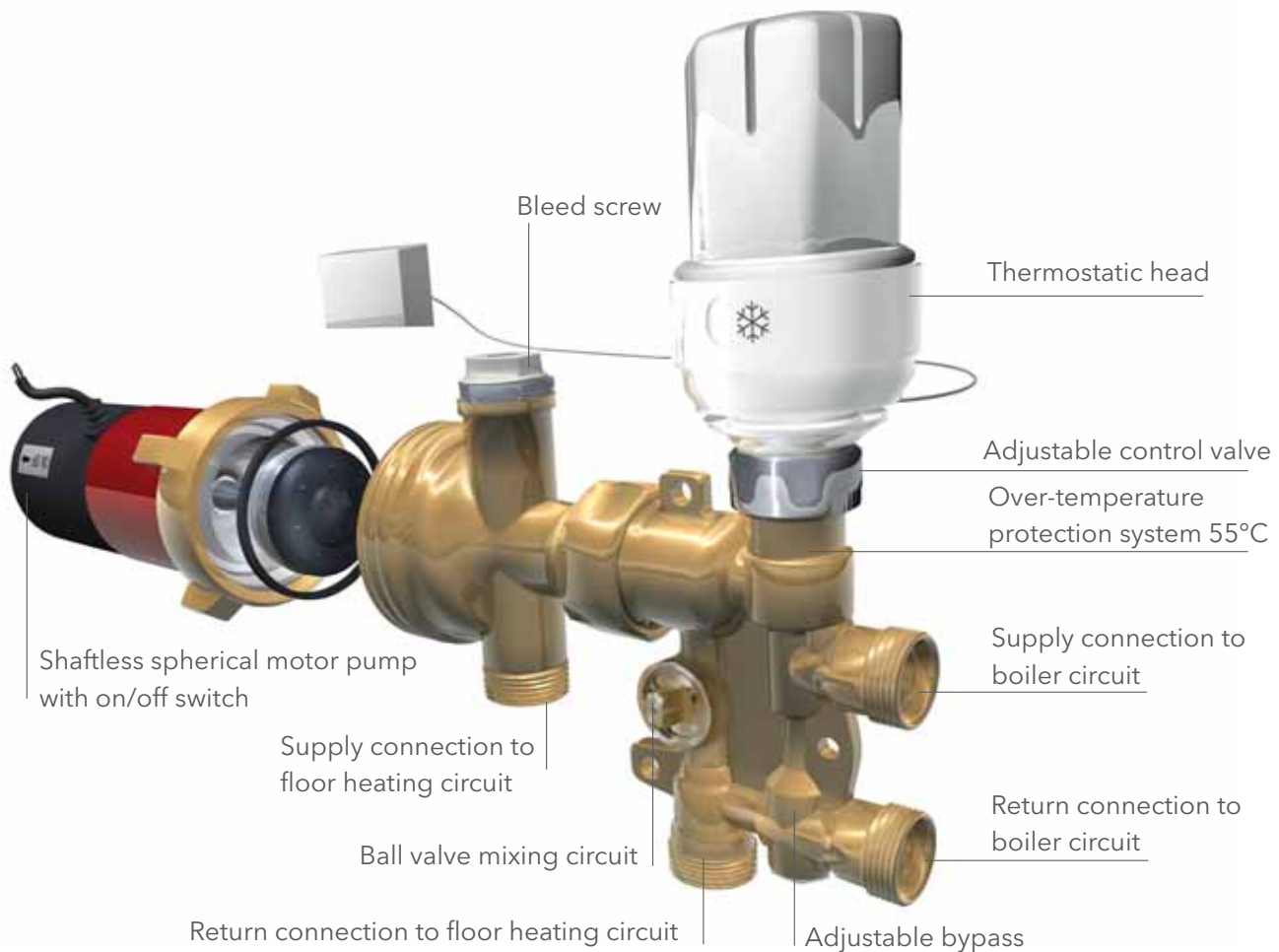

## Technical Data

Max. system pressure	1 MPa (10 bar)
Max. system temperature	110°C (radiator circuit) 55°C (floor heating circuit)
Max. differential pressure	100 kPa (1 bar) within radiator circuit
Supply voltage	1 x 230 V / 50 Hz
Power consumption	25 Watt (circulation pump)
Dimensions BM mini	L 265 x H 195 x D 90 mm
Connection	Eurocone 3/4"
Distance supply / return	40 mm radiator connection 59 mm floor heating connection
Weight	2,3 kg

## Pump curve.

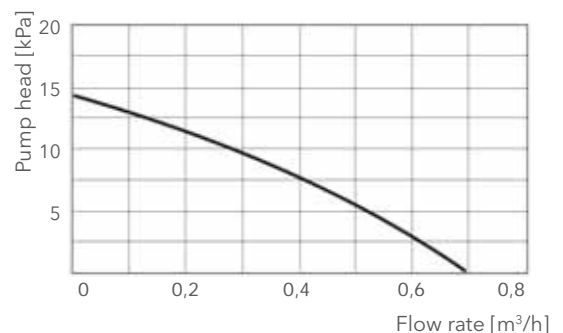

# Individually adjustable room station for surfaces up to 40 m<sup>2</sup>.

## Application.

With the BM mini mixing module, surface heating systems (up to 2 circuits and up to 40 m<sup>2</sup>) can be directly connected to a radiator circuit and can be adjusted according to a desired room temperature. The 40 m<sup>2</sup> surface specification is based on an inside diameter of the floor heating pipe of min. 12 mm (e.g. plastic pipe 16x2 mm or copper pipe 15x1 mm); the max. pipe length per heating circuit should not exceed 100 m with a 10 K difference. For smaller pipe diameters corresponding reductions have to be made.

The enclosed mounting bracket allows a left or right sided connection to the radiator circuit. Thanks to an integrated bypass valve the BM mini can also be connected to less conventional single pipe systems.

The model BM mini KF is particularly suitable for bathrooms and other damp rooms, thanks to the thermostatic head, which works without electricity, together with a capillary remote sensor. The supply temperature required for the respective surface heating system can be adjusted either indirectly through the flow in the control valve (model KF + RT), or directly through a constant temperature control (model KR). The integrated spherical motor pump ensures an even temperature distribution and a constant comfortable temperature level. The BM mini is also provided with an integrated over-temperature protection system, which restricts the supply temperature in the floor heating circuit to max. 55°C. A ball valve in the mixing section enables an easy cleaning of the floor heating circuit. With the BM mini

the room temperature can be adjusted either through a thermostatic head with a capillary remote sensor (model KF), or through a thermoelectric drive (model RT + KR), which has to be connected to a room thermostat (to be ordered separately). Also a wireless radio control can be delivered on request.

## Comparison between a BM mini and Return Temperature Limiters (RTL valves).

Connecting a surface heating system to a BM mini, compared to RTL valves (Return Temperature Limiter), has many advantages (see pictures on next page): even heat distribution through the integrated circulation pump

---

possibility to connect surfaces up to approx. 40 m<sup>2</sup>

---

no limitation to the radiator supply temperature; also old boiler systems with a supply temperature up to 110°C can be easily connected

---

integrated over-temperature protection system (55°C)

---

supply temperature adjustable either by setting the admixed volume flow (model KF and RT), or by using the integrated constant temperature control (model KR)

---

especially suited for the connection of renovation systems with low construction heights



**Model BM mini KF**  
Room temperature control with thermostatic head



**Model BM mini RT**  
Room temperature control with room thermostat (not included).



**Model BM mini KR**  
Constant temperature control connected to optional room thermostat (not included)

# Comparison BM mini with RTL valve.

Example of BM mini

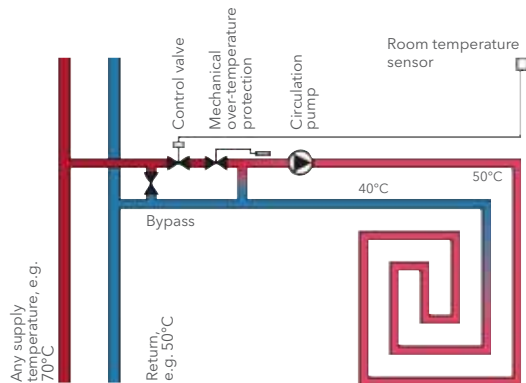

Example of RTL valve

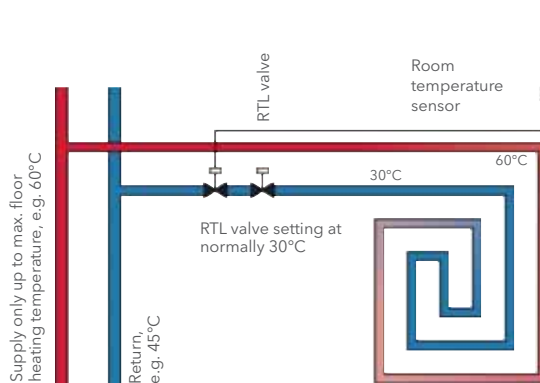

## Dimensional drawing BM mini (all measures given in mm)

BM mini KF

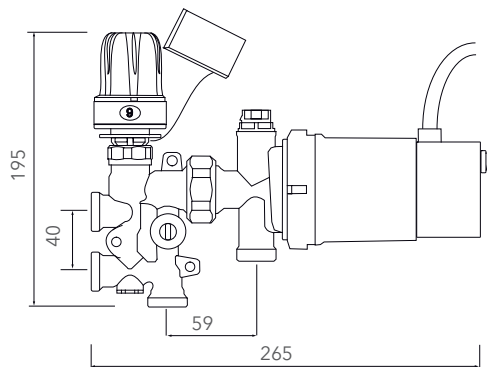

BM mini KR

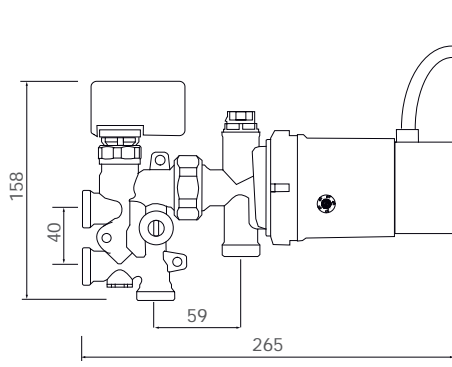

BM mini RT

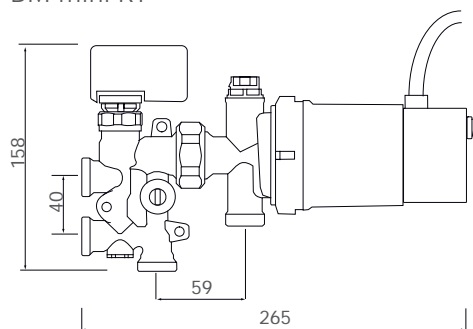

## BM mini.

Mixing module (eurocone connection 3/4")  
incl. shaftless spherical motor pump with  
on/off switch and power cable (1m), pre-  
adjustable thermostatic valve, mounting  
bracket for connection on left or right side,  
over-temperature protection system (55°C),  
adjustable bypass for connection to one  
pipe system, bleed screw.

Model	Part number	Description	Product category
BM mini KF	LH 49 00 920	With room temperature control, composed of thermostatic head (10-26°C and freeze protection) and capillary remote sensor (5m)	
BM mini RT	LH 49 00 921	With room temperature control, composed of electrical drive for connection to a room thermostat (room thermostat to be ordered separately)	7 Y
BM mini KR	LH 49 00 922	With integrated constant temperature control (20-70°C) for additional connection to a room thermostat for adjustment of room temperature (room thermostat to be ordered separately)	

## Accessories, components and spare parts for BM mini.

Model	Part number	Description	Product category
DXG	LH 95 00 175	Duplex screw connection (supply and return manifold for 2 loops)	
RTS	LH 95 00 403	Room thermostat (gas-expansion membrane without thermal feedback, 230V / 50 Hz), control range 10-30°C, protection class II, max. room temperature 50°C, dimensions H 76 x W 82 x D 38 mm, white	
RTZ	LH 95 00 450	Room thermostat (bimetal with thermal feedback, 230 V / 50 Hz), control range 5-30°C, protection class IP 30, max. room temperature 50°C, dimensions H 74 x W 74 x D 23 mm, white	
S-BM mini A	LH 95 00 984	Flush mounting cabinet with galvanized steel sheet with door, (door and frame white primed) incl. 2 mounting rails and fixing material, packed in carton. Recess dimensions H 330 x W 320 x D 115-170 mm	
S-BM mini B	LH 95 00 986	Cabinet (H 320 x W 410 x D 135 mm) with galvanized steel sheet (covering white primed) with 2 mounting rails and fixing material for the BM mini, packed in carton	7 Y
A1-121	LH 95 00 288	Replacement motor for the BM mini KF and RT, with on/ off switch and power cable (1m), incl. union nut and flange gasket	
A1-121 R	LH 95 00 289	Replacement motor for the BM mini KR, with integrated constant temperature control (20-70°C), on/off switch and power cable (1m), incl. union nut and flange gasket as well as pre-mounted electrical drive MTWZ-RT	
MTWZ-KF1	LH 95 00 410	Thermostatic head with room temperature capillary remote sensor (5m), incl. mounting housing (control range 8-26°C and freeze protection)	
MTWZ-RT	LH 95 00 411	Electrical drive (230 V / 50 Hz), normally-closed, incl. power cable (0.9 m)	
BM mini GM	LH 95 00 929	BM mini base module incl. mounting brackets and tool for pre-adjustment, but without circulation pump	

# Mixing module BM eco

Highly efficient circulation pump with continuously adjustable speed control and safe-off option

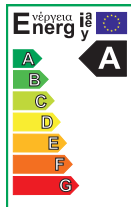
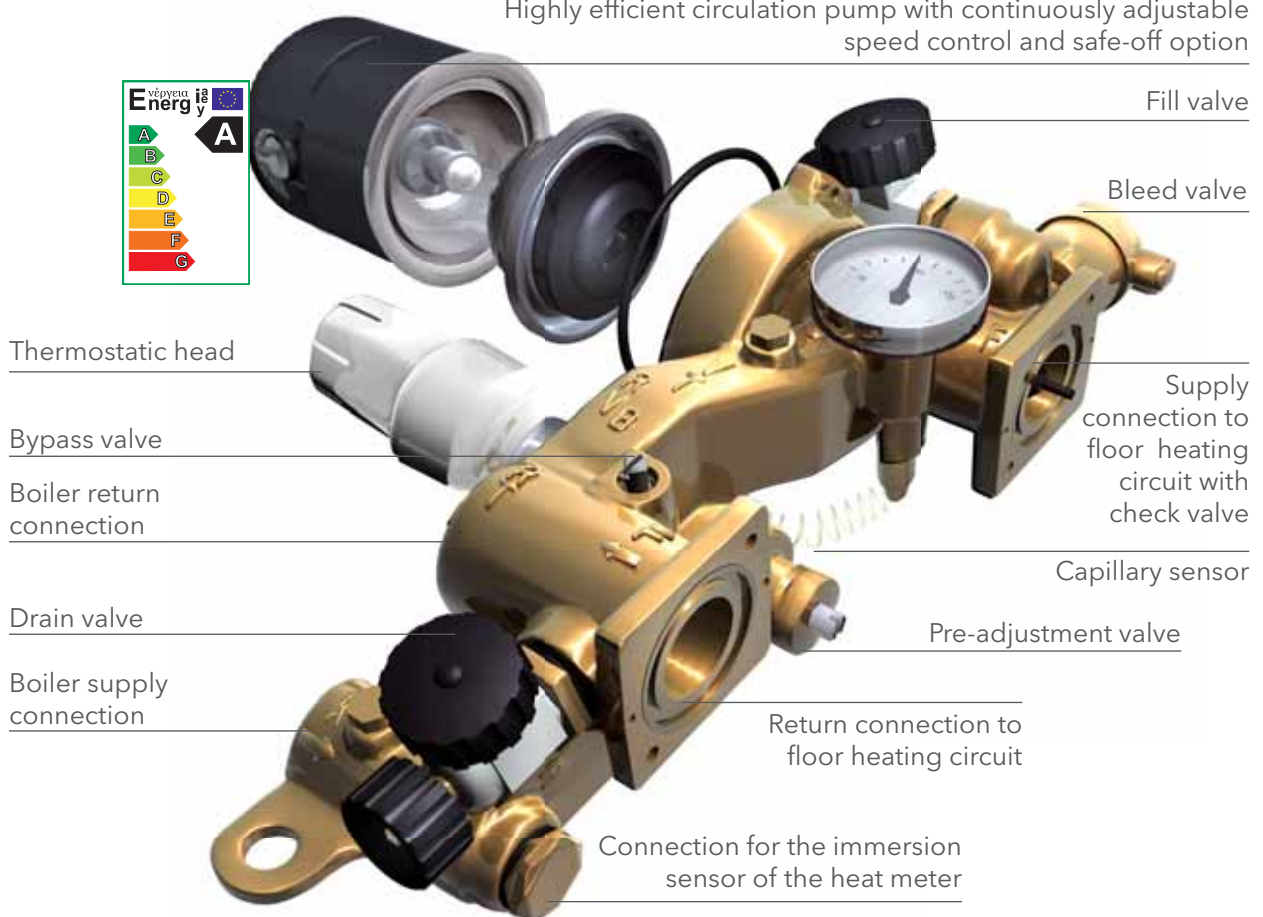

## Technical Data

Max. system pressure	1 MPa (10 bar)
Max. system temperature	105°C (radiator circuit) 60°C (floor heating circuit)
Max. differential pressure	100 kPa (1 bar) within radiator circuit
Supply voltage	1 x 230 V / 50 Hz
Power consumption	9 - 35 Watt (circulation pump)
Dimensions BM mini	see dimensional drawing
Connection to floor heating circuit	Supply and return both 1" female thread and flat connection for plastic segmented manifold
Connection to boiler circuit	Supply and return both 3/4" female thread to the ball valve
Weight	2,3 kg

## Pump curve.

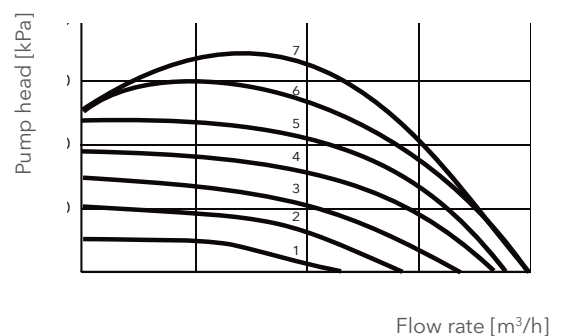



# Individually adjustable apartment station for surfaces up to 200 m<sup>2</sup>.

## Areas of application.

With the BM eco mixing module it is possible to easily connect manifolds to a boiler circuit for floor, wall, ceiling and outdoor underfloor heating. Surface heating systems up to approx.

200 m<sup>2</sup> can be directly connected to a radiator circuit and can be adjusted according to a desired room temperature. The BM eco is conceived for oxygen tight surface heating systems.

## Design principle.

The connection of the low temperature heating to the boiler circuit is performed via a mixing station, in which control, control valve, overtemperature protection and a high efficiency class A circulation pump for low temperature circuits are integrated. The compact dimensions and the resistant silent spherical motor pump allow the installation directly in the living area (recess or flush mounting cabinet). By using a single installation the mixing module can also be used without a boiler pump. The slightly modified connection to the boiler circuit is clearly explained in the instruction manual. The BM eco mixing module can be combined with various plastic and brass manifolds (not within the scope of delivery). The Mixing Modules are completely corrosionresistant, as they are made out of bronze.

## Integrated controls.

Thanks to the integrated thermostatic head the BM eco mixing module has robust and easy-to-operate controls, which allow a continuously variable adjustment between 20°C and 55°C of

the desired supply temperature. A capillary sensor registers the floor heating supply temperature and keeps it constant within a necessary proportional band. The integrated thermostatic head consequently closes or opens the primary valve of the mixing module according to the demands of the floor heating. In this way a bigger or a smaller quantity of hot water from the primary circuit is mixed according to the floor heating, reaching the desired temperature reliably.

The pump of the BM eco has a LED in the power selector of the high efficiency pump that precisely shows the operating status of the system. This mechanism is controlled through a high-performance microprocessor situated in the pump. Through this power selector it is also possible to completely switch off the system without any problems.

Integrated over-temperature protection system A mechanical strap-on thermostat, independent from the controls, is responsible for the overtemperature protection.

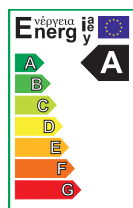

The integrated shaftless spherical motor pump with ECM technology meets all requirements of the high efficiency class A pump! With only 9-35 Watt electricity consumption of the circulation pump the BM eco sets standards.

Dimensional drawing BM eco in mm

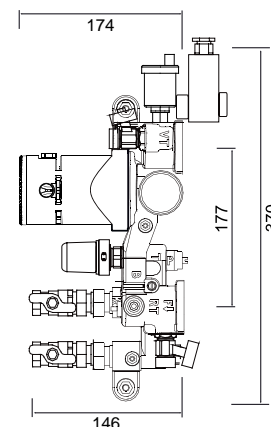

## BM eco base module.

Bronze mixing module with pre-adjustable control valve; with integrated continuously adjustable highly efficient circulation pump of energy efficiency class A; adjustable bypass for transmission ratio control; filling device, check valve, thermometer, automatic bleed valve; 1/2" female thread connecting piece with shut-off plug for connection of the heat meter immersion sensor (not included); boiler connection on link side with shut-off ball

valves (3/4" female thread); connection for floor heating manifold on right side (1" female tread); incl. constant temperature control through thermostatic head (20-55°C) and integrated over-temperature protection system (adjustable 20-90°C). The model BM eco ZR comes additionally with pre-mounted zone terminal block and pump shut-off module; plastic segmented manifold incl. control valve and flow meter.

Model	Part number	Dimensions B x H x D (in mm)	Product category
BM eco BM eco ZR	LH 49 00 911 LH 49 00 913	174 x 390 x 110*	7 Y

## Accessories, components and spare parts for BM eco.

Model	Part number	Dimensions	Product category
MTWZ-KF2	LH 95 00 412	Thermostatic head with plug-in sensor (capillary length 0.5m) for control range 20-55°C, for BM2 valve	
ATM2eco	LH 24 00 602	Highly efficient standard replacement pump of energy efficiency class A, for BM eco / BM 2 / BM 2 KF (strap-on thermostat model AT no. 95 00 400 for BM 2 KF to be ordered separately if needed), pump head 4m, 9-35 Watt	
ATM6eco	LH 24 00 606	Highly efficient special replacement pump of energy efficiency class B,v for BM eco / BM 2 / BM 2 KF (strap-on thermostat model AT no. 95 00 400 for BM 2 KF to be ordered separately if needed), pump head 6m, 9-63 Watt	7 Z
VSVA	LH 95 00 113	Manifold segment for floor heating return for BM eco	
VSRA	LH 95 00 115	Manifold segment for floor heating return for BM eco	
D180	LH 95 00 212	Flow meter insert for VSRA, colour green, measurement range 30-177 l/h	
D250	LH 95 00 213	Flow meter insert for VSRA, colour red, measurement range 60-250 l/h	
AEB 1"	LH 95 00 265	1" connection block to right end of manifold	
BM-WMZ	LH 95 00 971	Heat meter connection kit with adapter 110 mm x R 3/4"	
TH14	LH 95 00 215	Thermometer	

## Single room controls for BM eco.

All BM eco mixing stations already have an integrated supply temperature control and an over-temperature protection system. Together with the zone control it is possible to easily install a single room control if necessary. The pump shut-off module already

integrated in the zone terminal block further reduces the electricity costs of the BM eco highly efficient pump, as it activates the pump only when at least one room demands heat. It is also not necessary to switch off the system manually during summertime.



Model	Part number	Description	Product category
ZKL 12	LH 95 00 434	<b>Zone terminal block module</b> For the connection of max. 6 room thermostats and max. 12 drives with integrated pump shut-off module. Single, group or complete zone setback possible if RTR room thermostats are used.	
TEA	LH 95 00 402	<b>Drive</b> Operating voltage 230 V, 50 Hz, normally-closed valve, thread M 30x1.5, max. opening / closing time 3.5 min / 5 min, power cable 1200 mm, dimensions H 55 x Ø 44 mm, colour light grey	
RTZ	LH 95 00 450	<b>Room thermostat</b> (Bimetal with thermal feedback), control range 5-30°C, switch temperature difference approx. 0.5°C, operating voltage 230 V, 50 Hz, protection class IP30, max. room temperature 50°C, dimensions H 74 x W 74 x D 23 mm, colour white	7 Z
RTR	LH 95 00 451	<b>Room thermostat with setback</b> (Bimetal with thermal feedback), control range 5-30°C, setback approx. 4 K, switch temperature difference approx. 0.5 K, operating voltage 230 V, 50 Hz, protection class IP30, max. room temperature 50°C, dimensions H 74 x W 74 x D 23 mm, colour whit	
RTU	LH 95 00 404	<b>Electronic thermostat with timer</b> Control range 5-40°C, power supply 2x1.5 V AA-batteries, max. switching current 10 A, 250 V AC or 24 V, switching temperature difference +/- 0.5 ... +/- 1.5 K, max. room temperature 50°C, dimensions H 82 x W 132 x D 32 mm, colour white, LCD display	

# What can Xylem do for you?

Xylem ['zīləm]

- 1) The tissue in plants that brings water upward from the roots;
- 2) a leading global water technology company.

We're 12,000 people unified in a common purpose: creating innovative solutions to meet our world's water needs. Developing new technologies that will improve the way water is used, conserved, and re-used in the future is central to our work. We move, treat, analyze, and return water to the environment, and we help people use water efficiently, in their homes, buildings, factories and farms. In more than 150 countries, we have strong, long-standing relationships with customers who know us for our powerful combination of leading product brands and applications expertise, backed by a legacy of innovation.

**For more information on how Xylem can help you, go to [xylem.com](http://xylem.com).**



LOWARA S.r.l. Unipersonale  
Via Vittorio Lombardi, 14  
36075 Montecchio Maggiore  
Vicenza - Italy  
Tel. (+39) 0444 707111  
Fax (+39) 0444 492166  
e-mail: [lowara.mkt@xylem.com](mailto:lowara.mkt@xylem.com)  
[www.lowara.com](http://www.lowara.com)  
[www.completewatersystems.com](http://www.completewatersystems.com)

Lowara is a trademark of Xylem Inc. or one of its subsidiaries.