

50 Hz

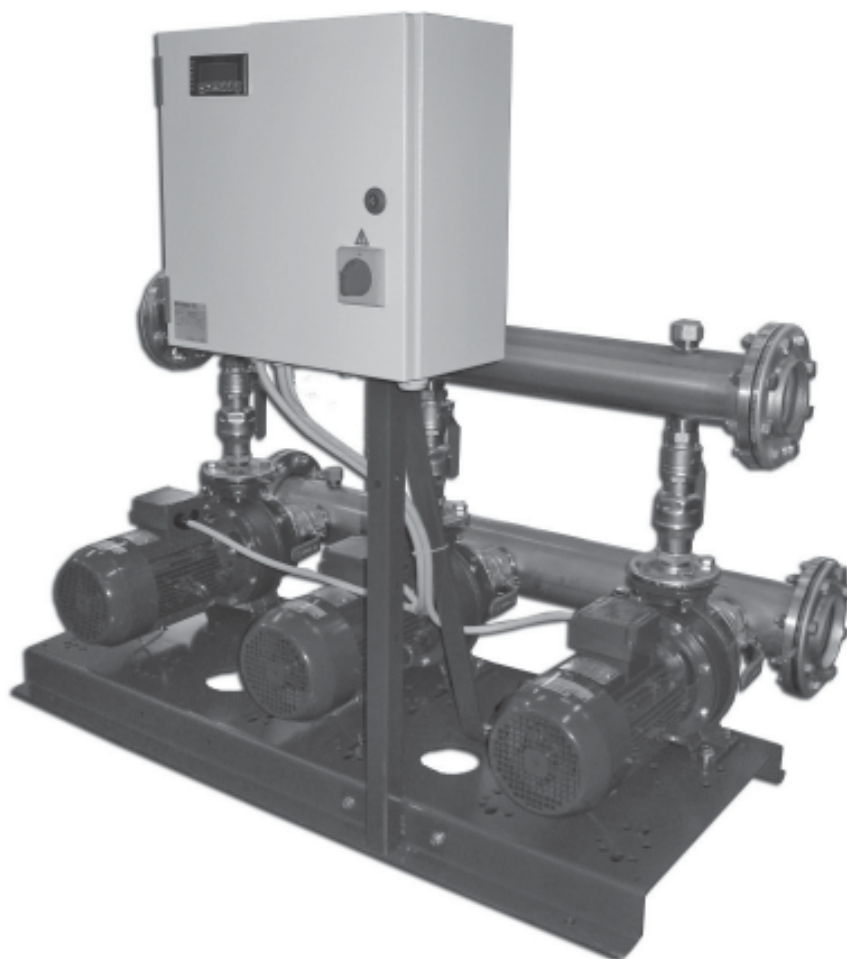

GS20-GS21-GS30 Series

FIXED-SPEED PRESSURE BOOSTER SETS WITH
HORIZONTAL CENTRIFUGAL ELECTRIC PUMPS FH and SH SERIES

CONTENTS

General introduction	5
Choice and selection	6
GS.../FH Series	13
Range	15
Characteristics of the electric pumps	16
Hydraulic performance tables	21
Electric data tables	24
GSD20 - GSY20 Series	25
GSD21 - GSY21 Series	31
GSD30 - GSY30 Series	39
Operating characteristics at 50 Hz	46
Hc pressure drop curve	59

CONTENTS

GS.../SH Series	63
Range	65
Characteristics of the electric pumps	66
Hydraulic performance tables	71
Electric data tables.....	74
GSD20 - GSY20 Series	75
GSD21 - GSY21 Series	81
GSD30 - GSY30 Series	89
Operating characteristics at 50 Hz	96
Hc pressure drop curve	110
Accessories	113
Technical Appendix	117

BOOSTER SETS GS SERIES GENERAL INTRODUCTION - PRODUCT DESCRIPTION

The GS series pressure booster units mainly comprise pumping stations assembled with two or three SV series vertical multistage pumps, or with FH or SH series enbloc horizontal pumps. A smaller pump can also be added to the main ones. Generally known as a jockey pump, it provides for minor usages in order to maintain system pressure without starting the service pump.

The GS series pressure booster units are constant speed sets and are used to distribute water in heating or filling systems.

The pumps are mounted on a single base together with the other hydraulic components, such as on-off valves, check valves and the delivery and return manifolds.

The electrical panel, supplied with a mounting bracket, is attached to the pressure booster unit base.

The pumps start and stop according to the signals sent by the pressure transducer to the electrical control panel.

The latter is fitted with an integrated electronic board. The pumps start and stop automatically depending on the water demand of the system.

These pressure booster systems are combined with suitable expansion tanks in order to guarantee stable operation and reduce the starting frequency of the pumps.

For the correct choice in capacity of the expansion vessel, see the relative chapter on page 126 of the catalogue.

DESCRIPTION OF OPERATION

The pumps start and stop according to the set pressures detected by the pressure transducer, thus ensuring the required amount of water is delivered. The pressure values can be directly set on the electronic board.

For units with jockey pump, the latter will start first and stop last, depending on the set pressure values.

When a tap is opened, water is drawn off from the tank, the pressure starts to fall until it reaches the starting value of the first pump. The delivery of water increases, the pressure falls even further and the other pumps start in sequence according to the demand for water.

When consumption falls, the pressure in the system increases and the pumps stop when the set threshold pressure values are reached.

If consumption falls to zero user demand, the last pump also stops.

If the "timer" function is used, the last pump to work will remain operating for a set time after it is switched off, in order to reach maximum pressure. Make sure the maximum pressure is compatible with the system in which the pump is installed.

Example: GS series pressure booster units, operation.

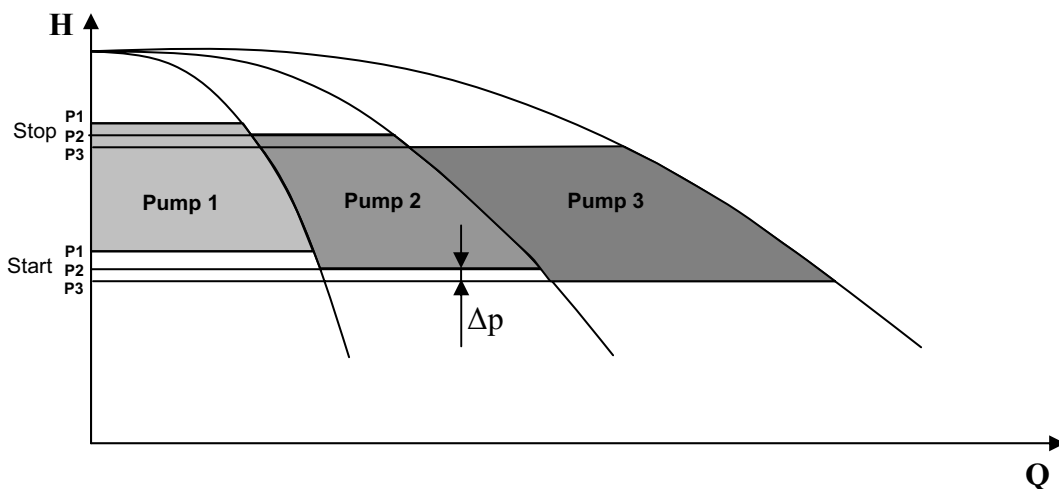

Δp pressure differential between pumps, can be reduced to 0,5 bar.

BOOSTER SETS GS SERIES CHOICE AND SELECTION

The demand of a water distribution system is generally determined by the designer according to the type of user structure being served.

Users can be schools, hospitals, homes, offices, industries, hotels, shopping centres and for each the water demand changes due to the different requirements of the people living and working in these structures. To find the correct flow rate for the system in question, it is possible to consult pre-calculated tables that give an idea of the flow rate for the typology of user to serve (see pages 118-119 in this catalogue).

Integral system calculation, instead, prevents excessive oversizing and therefore reduces running and installation costs.

The theoretical water demand is calculated by summing the demand of each user. As, however, it is improbable that all users will want to use water at the same time, real demand is lower than theoretical demand.

After defining the flow rate of the system, the head must be calculated. This must consider the following:

- geodesic head: difference in level between the pumping station and the highest user
- residual head: pressure demand from the most unfavourable user to serve
- pressure drops: value in metres of pressure drops due to friction in the delivery pipes
- inlet height: difference in level between the pump inlet and the surface of the water in the tank (positive or negative depending on the installation type)
- inlet pressure drops: value in metres of pressure drops due to friction in the inlet piping and in any curves and valves.

After analysing the above, the head required for the system is calculated.

Now that the flow rate and head values are known, the most suitable pressure booster unit for the system can be chosen. The designer must decide whether to choose a pressure booster unit with two or three pumps, the third being a reserve pump satisfying demand during pump maintenance periods.

INSTALLATION

The GS series of pressure booster units must be installed in areas protected from frost and adequately ventilated in order to allow the motors to cool. The delivery and intake pipes should be connected using anti-vibration joints in order to limit vibrations and resonance in the system.

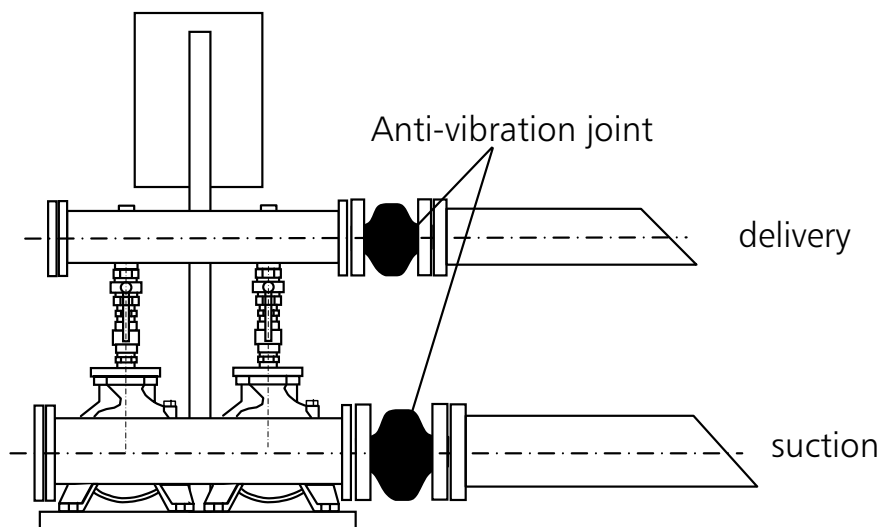

BOOSTER SETS GS SERIES INSTALLATION

The GS series of pressure booster units are generally connected to pressurised tanks with a suitable capacity for the system. These tanks are normally expansion vessels for capacities up to 500 L. Tanks with higher capacities can also be supplied if necessary. In these cases, they are air-cushion tanks and a compressor is required to maintain the pressure inside the tank.

In both cases, the tanks must be connected on the pressure booster unit delivery line. The system, commonly known as an "autoclave", provides the system with a reserve of pressurised water and prevents frequent pump start-ups.

For these systems, sufficient space must always be allowed in the area where the pressure booster set is installed.

Always check maximum pump pressure in order to choose the right tanks for the pressure in question.

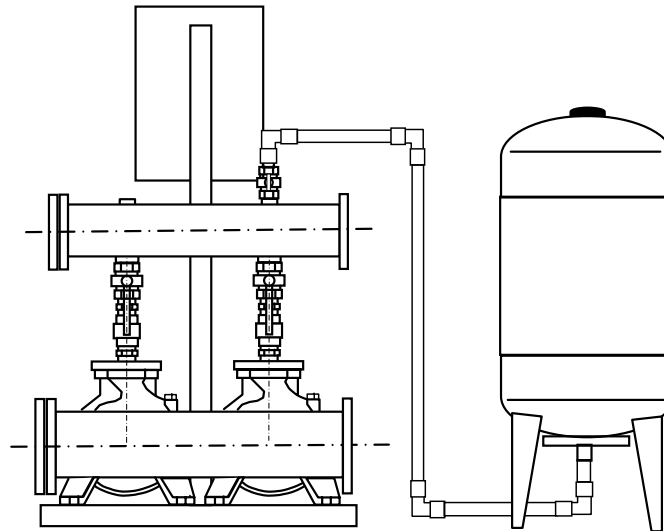

SUCTION CONDITIONS

Installation of the pressure booster set must be assessed especially as regards intake conditions. Intake conditions can negatively or positively affect the performance of the pressure booster unit and consequently system performance. A positive suction head is ideal for a pressure booster unit as it keeps the pumps constantly primed and the positive difference in level adds pressure to the system.

A negative suction head is different. In this case, the risks for the pumps are priming which is connected with the intake piping, the NPSH of the pump and the difference in level between the pump and the water in the tank.

In this type of installation, after checking the intake capacity of the pump, the overall pressure drop in the intake line must be calculated as this will reduce pump performance and consequently that of the pressure booster unit.

In order to select the right pressure booster unit, the performance levels of the pumps installed on them are indicated in this catalogue. To simplify the calculation of net pressure, pressure drop curves, both for the delivery and intake lines of the pumps have been included (see the relative chapter).

BOOSTER SETS GS SERIES CALCULATING NET PRESSURE

When selecting the GS series of pressure booster units, reference must be made to pump performance. Performance is calculated from the characteristic curves of the pumps and does not consider any pressure drops generated by pipes and valves as in the pressure booster units. To help choose the right pressure booster unit and calculate the correct pressure at the delivery manifold, the following example is shown:

Given the duty point $Q = 60 \text{ m}^3/\text{h}$ $H = 36 \text{ mca}$ and with two pumps working, the pump with the most suitable characteristic curve is chosen, that is, the one with a curve that guarantees the required flow and head values.

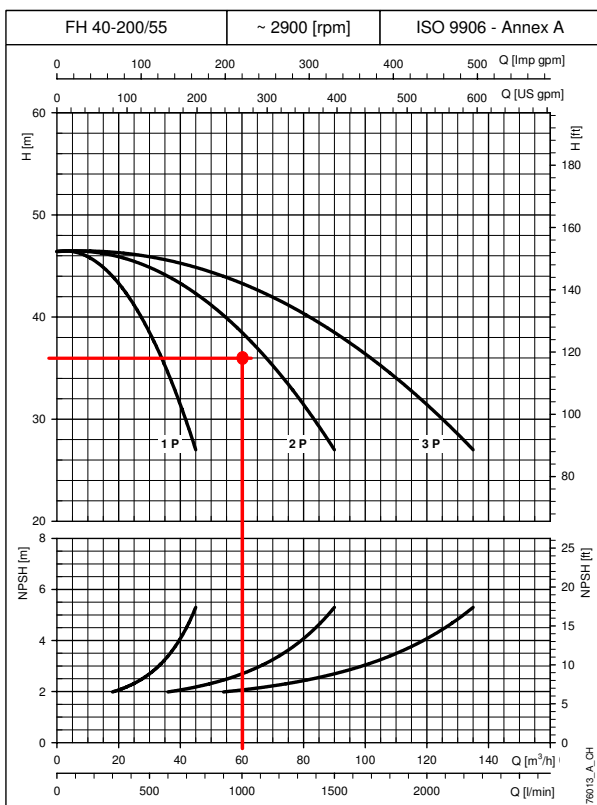

From the example, we have chosen the FH40-200/55 series pump which guarantees system performance. The pump curve is slightly oversized, but this provides a safety margin to counter the pressure drops in the pressure booster unit pipes.

To know the effective pressure at the delivery manifold outlet, the pressure drops in the suction and delivery lines of each pump are calculated.

To simplify calculations, the pressure drop curves for each pump, on page 131 of this catalogue, are used.

Assuming a pressure booster unit with check valves on the suction line (curve B of Hc pressure drops) has been selected, one proceeds as follows:

The Hc pressure drops on the pump suction line are to be evaluated on the "B" curve. At a flow rate of $30 \text{ m}^3/\text{h}$ the value of $H_c = 1,2 \text{ m}$.

Similarly, the Hc pressure drops on the delivery line of the pump, as evaluated on the "B" curve, are analysed. At a flow rate of $30 \text{ m}^3/\text{h}$, the value of Hc is $0,02 \text{ m}$.

The total pressure drop on the delivery and suction lines is therefore $1,22 \text{ m}$.

As regards the pressure drop in the suction and delivery manifolds, 5% with respect to the pressure drops in the pump suction and delivery can be considered.

In this case, therefore, the value is $0,061 \text{ m}$.

The total pressure drop is approximately: $1,281 \text{ m}$.

Analysing the performance of the unit at a flow rate of $60 \text{ m}^3/\text{h}$, the head H is 38 m .

The net pressure at the delivery manifold is $38 - 1,281 = 36,7 \text{ m}$.

Comparing this value with the rated value, $36,7 \text{ m} > 36 \text{ m}$.

The unit can therefore satisfy the demand of the system.

BOOSTER SETS GS SERIES SUCTION CONDITIONS

The above example does not consider the suction conditions of the pressure booster unit which, similarly, affect final performance. It is therefore always best to check the suction line for leaks, especially as regards positive head installations.

An example of positive head installation relative to the above case is shown below:

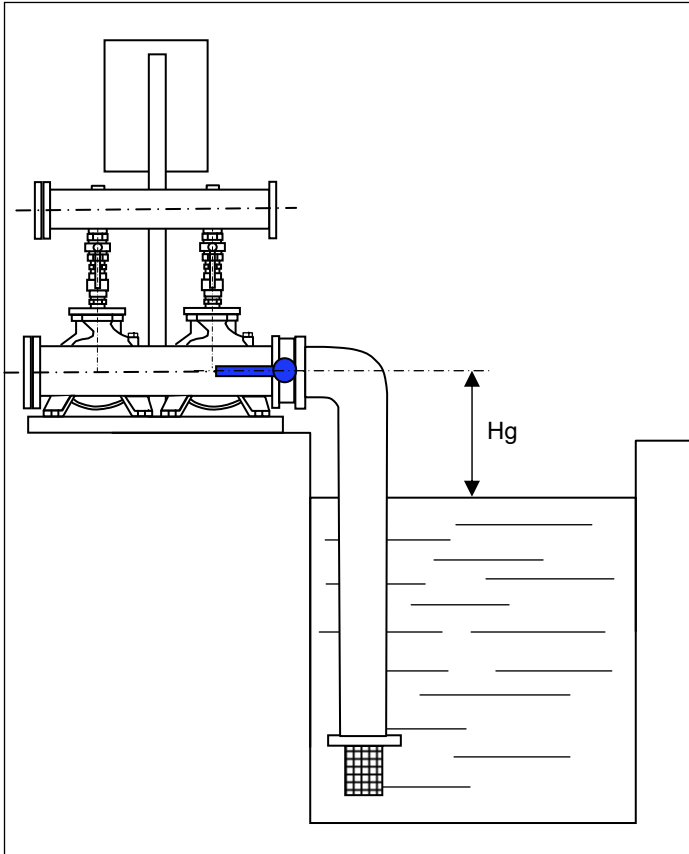

In the positive head installation, the designer must calculate the minimum installation height H_g of the pump in safety conditions in order to avoid cavitation and, therefore, de-priming of the pump.

The relationship that must be checked and which connects this measurement is the following:

$NPSH_{available} \geq NPSH_{requested}$ where equality is the limit condition.

$NPSH_{available} = P_{atm} + H_g - \sum \text{pressure drops}$.

Where:

P_{atm} is the atmospheric pressure, equal to 10,33 m

H_g is the geodetic difference in level

The pressure drops are connected with to the suction piping and relative valves (foot and cut-off valves)

$NPSH_{requested}$ is a pump parameter taken from the performance curve of the pump which in our case, at a flow rate of 30 m³/h corresponds to 2,5 m.

Before calculating the $NPSH_{available}$, the suction pressure drops are calculated using the tables on pages 199-200 in this catalogue, considering a material such as steel.

The chosen diameter of the suction piping is DN100.

90° curve DN100 = 2,96 m

Damper DN100 = 0,56 m

Drain valve DN100 = 0,39 m (calculated from supplier data)

Piping DN100 = 0,27 m (assuming a length of 2,5 m)

Piping DN100, intake manifold = 0,1 m (length of manifold 0,89 m)

Pressure drops on pump suction side (curve B) = 1,2m

\sum pressure drops = 5,48 m

Remembering that: $NPSH_{available} = 10,33 + H_g - 5,48$

Replacing: $10,33 + H_g - 5,48 \geq 2,5$

$H_g = 2,5 + 5,48 - 10,33 = - 2,35$ m representing the limit, for which reason: $NPSH_{available} = NPSH_{requested}$

Generally speaking, therefore, in order to assure correct operating conditions as regards the risk of cavitation, the pump must be positioned above the level of the tank so that the suction height is lower than the limit value of 2,35 m.

SET IDENTIFICATION CODE

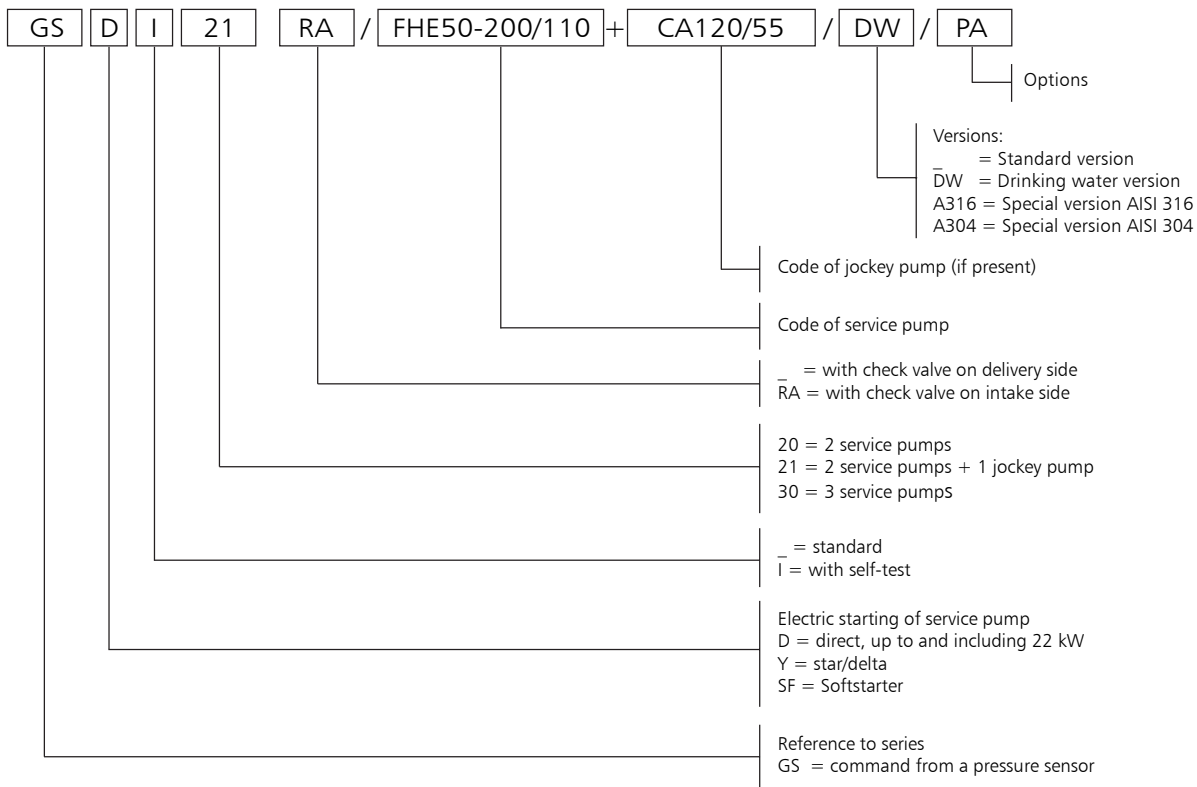

OPTIONS (ON DEMAND)

BAP	High pressure switch installed on the delivery manifold.
CM	Oversized suction or delivery manifold.
CV	Unit with expansion vessels (normally 24 litres supplied separately and not mounted).
IP65	Control panel versions IP65.
KV	Voltmeter Kit with phase switch.
MA	Pressure gauge installed on suction manifold.
PA	Minimum pressure gauge installed on the suction manifold for dry-running protection.
RA	Check valves installed on suction side.
RE	Panel incorporating a thermostat-controlled anti-condensate heater.
RV	Electrical panel with missing-phase, phase-asymmetry, minimum – maximum voltage control.
SA	No intake: no suction valves and suction manifold.
SC	Group with no control devices, such as pressure switches and transmitters; the pressure gauge is present.
SCA	No suction manifold (suction valves present).
VA	Electric control panel fitted with analogue voltmeter and ammeter.
WM	Wall-mounted electrical panel with fixing tabs. Cables L= 5m
PP	Pressure-switch control.

AVAILABLE VERSIONS

A304	Main component in contact with liquid in stainless steel Aisi 304 or superior; gasket, sealing tape and thread sealing are suitable for drinking water. Bolts and screws galvanized. Flanges not in contact with the liquid in galvanized steel.
B304	Main component in contact with liquid in stainless steel Aisi 304 or superior; gasket, sealing tape and thread sealing are suitable for drinking water. Bolts and screws in Aisi 304 or superior. Flanges not in contact with the liquid in Aisi 304 or superior.
C304	Main component in contact with liquid in stainless steel Aisi 304 or superior; gasket, sealing tape and thread sealing are suitable for drinking water. Baseplate, frame, supports, bolts and screws in Aisi 304 or superior. Flanges not in contact with the liquid in Aisi 304 or superior. Valves and their components completely in Aisi 304 or superior (body, disc, plate).
A316	Main component in contact with liquid in stainless steel Aisi 316; gasket, sealing tape and thread sealing are suitable for drinking water. Pumps in Aisi 316 material. Bolts and screws galvanized. Flanges not in contact with the liquid in galvanized steel.
B316	Main component in contact with liquid in stainless steel Aisi 316; gasket, sealing tape and thread sealing are suitable for drinking water. Pumps in Aisi 316 material. Bolts and screws in Aisi 316. Flanges not in contact with the liquid in Aisi 316.
C316	Main component in contact with liquid in stainless steel Aisi 316; gasket, sealing tape and thread sealing are suitable for drinking water. Pumps in Aisi 316 material. Baseplate, frame, supports, bolts and screws in Aisi 316. Flanges not in contact with the liquid in Aisi 316. Valves and their components completely in Aisi 316 (body, disc, plate).
DW	Main component in contact with fluid suitable for drinking water or in stainless steel AISI 304 or superior quality.

CONTROL PANEL FOR GS20, GS21, GS30

Electric panel for powering, controlling and protecting a maximum of three three-phase pumps, with sheet steel casing (fig. 1) and protected to IP55.

Main characteristics:

- General doorlock switch, fuse holders and fuses, starting contactors and circuit breakers.
- Standard input voltage: 3x400Vca +/-10%, 50/60Hz.
Non-standard voltages available on request, 1x230Vac +/-10%, 3x230ca +/-10%, 50/60Hz.
- Transformer for auxiliary low voltage circuit; auxiliary voltage 24Vac.
- Lowara SM30 digital microprocessor-controlled control unit with LCD display and programming keyboard (see fig. 2), featuring the following functions:

- Indicator lamps: power on (ref.1), general fault (ref.2), no water alarm (ref.3), pump running (ref.4);
- Programming keyboard (ref.5);
- Manual pump stop/start (one button for each pump) (ref.5);
- Automatic cascade pump control with two electronic pressure transmitters. If a sensor develops a fault, the board automatically switches to the second sensor.
Pressure switch control available on request.
- Jockey pump management.
- Cycle reversal function (can be disabled). Automatically switches pumps after every start/stop cycle.
- Automatic, manual or disabled mode switches for each pump (inside the board).
- Periodic system self-test with an electrovalve command which opens the hydraulic circuit, simulates a pressure drop and consequently activates the control devices (pressure switches and pressure transmitters). Pump diagnostics.

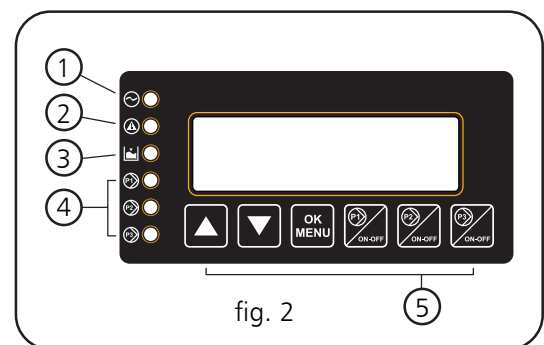

- No-water protection system alternatives: float, minimum pressure switch, external contact or electrode probes with sensitivity adjustment.
- Adjustable timer delaying tripping the no-water protection system.
- Adjustable timer delaying starting of each pump.
- Adjustable timer extending the operation of each pump.
- System pressure drop offset function, only available with pressure sensor. This function improves system stability.
- Adjustable analogue output, 0(4)-20mA or 0-2(10)Vdc, for visualising the analogue input signal.
- Configurable relay with volt-free contact, delayed activation, signalling the following conditions:
 - Motor overload protection alarm.
 - No-water circuit alarm.
 - Pressure sensor fault.
 - Out-of-curve operation alarms (only if self-test is disabled).
 - Maximum intake pressure alarm.
 - Electrovalve opening permission for self-test circuit.
- Configurable digital inputs.
 - AUX1 input configuration, maximum pressure switch or external self-test.
 - AUX2 input configuration, permission from external device (NO) or external alarm (NC).
 - AUX3 input configuration, change set (NO) or pressure switch operating out-of-curve.
- 12Vdc output for powering the acoustic alarm.

CONTROL PANEL FOR GS20, GS21, GS30

- Alarms log and hour counters for each installed pump. Alarms visualised on display:
 - Maximum, minimum pressure;
 - Circuit breaker for each motor;
 - Pressure transmitter fault.
 - Out-of-curve operation;
 - No water;
 - Block for tripped external device (PTC, temperature probe, etc.)
 - Auto-test failed

All the alarms light the Fault lamp (ref.2 – fig.2)

The no-water alarm lights the Level alarm lamp (ref.3 – fig.2)

- Standard, RS485 serial communication, slave, and ModBus RTU protocol.
- The GSM/GPRS module can be connected to send pump alarms and/or operating states via sms or e-mail. Connection via RS485 serial connection. SIM card not included.
- A relay board (optional) can be connected to boost the following signals: pump running, aut-man mode for each pump, overload alarm, no-water alarm, maximum/minimum pressure alarm, power on, self-test failed. The optional signal booster board has six relays, each of which can be configured using the Lowara SM30 control unit.

GS.../FH Series

Fixed-speed pressure booster sets
Horizontal Centrifugal electric pumps FH series
equipped with high efficiency motors
flow rate up to 630 m³/h

50 Hz

GS.../FH

GS.../FH SERIES
HYDRAULIC PERFORMANCE RANGE AT 50 Hz

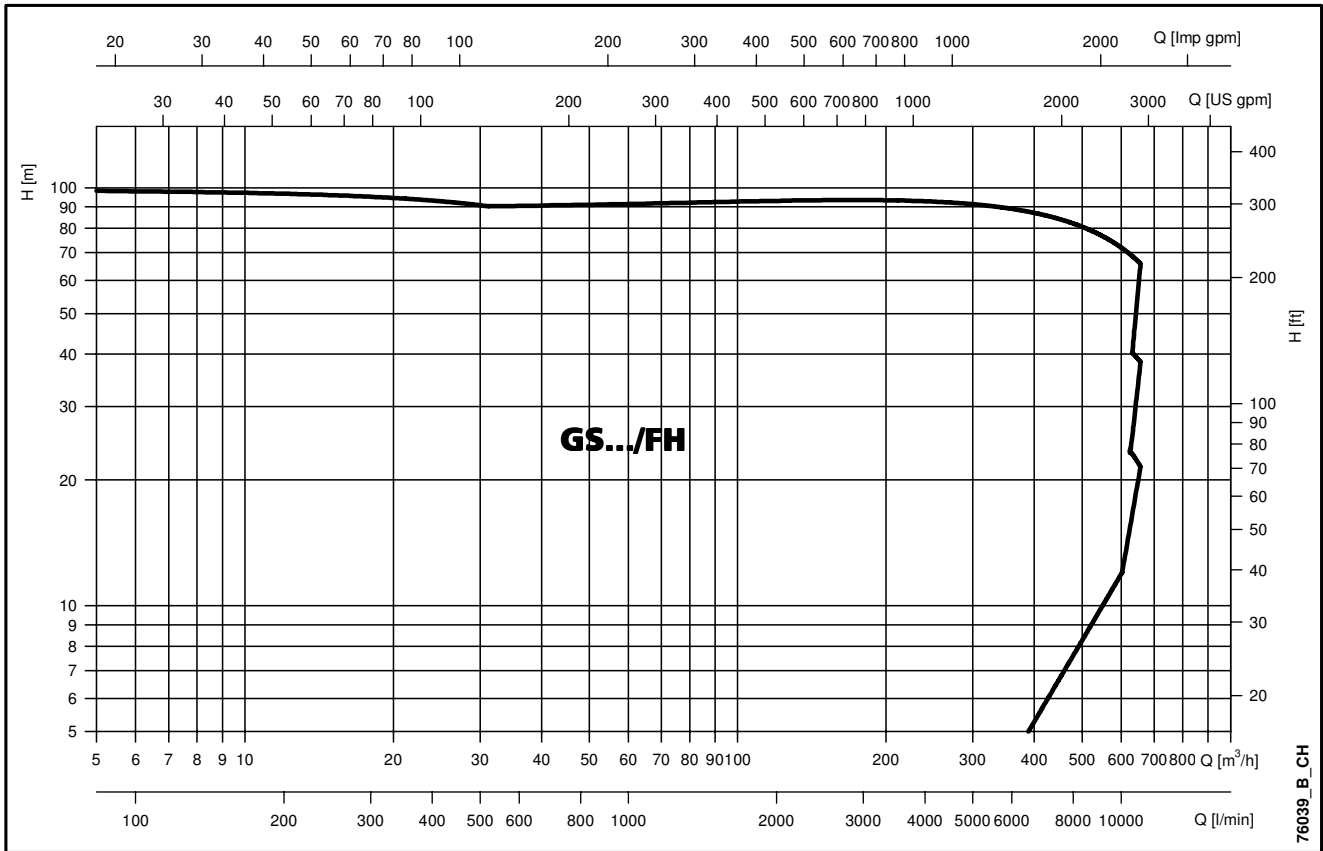

GS.../FH

RANGE

The GS series of fixed-speed pressure boosters comprises models with 2 or 3 electric service pumps and an optional jockey pump in order to satisfy the specific needs of every application.

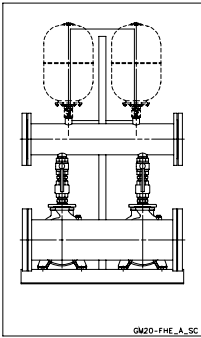

GS20 SETS

- Fixed-speed sets with two horizontal service pumps, FH series, with power ratings up to 55 kW.

Head up to 100m.
Flow rate up to 420 m³/h.

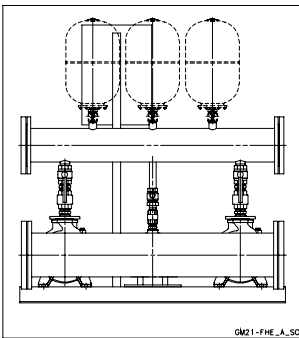

GS21 SETS

- Fixed-speed sets with two service pumps and a jockey pump. Horizontal service electric pumps, FH series, with power ratings up to 55 kW.

Head up to 100m.
Flow rate up to 420 m³/h.

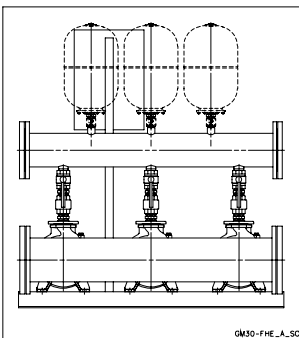

GS30 SETS

- Fixed-speed sets with three horizontal service pumps, FH series, with power ratings up to 55 kW.

Head up to 100m.
Flow rate up to 630 m³/h.

REFERENCE STANDARDS

- The Lowara booster sets are CE-marked for conformity with the following directives:
 - Machinery Directive: 2006/42/EC.
 - Low Voltage Directive 2006/95/EC.
 - Electromagnetic Compatibility Directive 2004/108/EC
- Electric pump performance complies with the following standard: ISO 9906-A Rotodynamic pumps – hydraulic performance acceptance tests.

CHARACTERISTICS OF THE ELECTRIC PUMPS

The FH series of horizontal centrifugal pumps are single-impeller (FHE, FHS) or twin-impeller (2FHE) with cast-iron bodies and AISI 316L stainless steel shafts.

Impeller: made of AISI 316L stainless steel laser technology welded, for sizes 32, 40, 50, 65-125, or cast iron for sizes 65-160, 65-200, 65-250, 65-315, 80, 100, 125, 150.

Hydraulic sizes and nominal diameter DN of suction and delivery ports according to EN 733 (ex DIN 24255).

Flanges according to EN 1092-2 (ex UNI 2236) and DIN 2532.

Motor: enbloc motor/pump coupling with bracket with impeller directly splined onto the motor shaft protrusion (FHE, 2FHE) or with joint, adaptor and rigid joint splined onto the shaft protrusion of normalised motors (FHS).



Technical data:

Flow rate: up to 650 m³/h (2 poles).
750 m³/h (4 poles).

Head: over 100 m (2 poles).
60 m (4 poles).

Temperature of pumped liquid:
from -20°C to +85°C for FH 32, 40, 50,
65, 80 standard version.
from -30°C to +120°C for FH 100, 125,
150 standard version (including
65-315, 80-315 and 80-400).
Up to +140°C for FH 100, 125, 150
on request.

Mechanical seal

Mechanical seal according to EN12756 (ex DIN 24960).

Mechanical seal lubricated from circulation duct between the delivery line and the seal for FH 32, 40, 50, 65, 80 (apart from 65-315, 80-315 and 80-400).

Seat for mechanical seal peg for FH32, 40, 50, 65, 80 (apart from 65-315, 80 315 and 80-400).

Anti-clockwise rotation looking at the pump from the suction port side.

Motor

Short circuit squirrel cage motor, totally enclosed, fan-cooled. **Standard supplied IE2/IE3 motors are compliant with Regulation (EC) no. 640/2009 and IEC 60034-30.**

Protection class IP55.

Insulation class 155 (F).

Performance levels according to EN 60034-1.

Continuous service.

Maximum ambient temperature: +40°C.

Condensate drain plugs on all LOWARA motors.

Standard voltage:

Single-phase version 220-240 V, 50 Hz

Three-phase version 220-240/380-415 V, 50 Hz for power ratings up to 3 kW;

380-415/660-690 V, 50 Hz for power ratings higher than 3 kW.

For electrical data of the motors used see Technical Appendix.

CHARACTERISTICS OF THE ELECTRIC PUMPS USED IN THE GS SERIES OF PRESSURE BOOSTER SETS

HORIZONTAL ELECTRIC PUMPS SERIES:

FHE 32, 40, 50, 65, 80

FHS 65, 80

- Twin-impeller (2FHE) or single-impeller (FHE, FHS) cast iron horizontal centrifugal pump and shaft made of AISI 316L stainless steel.
- Impeller: made of AISI 316L stainless steel laser technology welded, for sizes 32, 40, 65-125 or cast iron for sizes 65-160, 65-200, 65-250, 80.
- Hydraulic sizes and nominal diameter DN of suction and discharge ports according to EN 733 (ex DIN 24255).
- Flanges according to EN 1092-2 (ex UNI 2236) and DIN 2532.
- Motor: enbloc motor/pump coupling with bracket with impeller directly splined onto the motor shaft protrusion (FHE, 2FHE) or with joint, adaptor and rigid joint splined onto the shaft protrusion of normalised motors (FHS).
Standard supplied IE2/IE3 three-phase surface motors $\geq 0,75$ kW are compliant with Regulation (EC) no. 640/2009 and IEC 60034-30. Performance levels according to EN 60034-1.
- Painting: cathodic epoxy enamel.
- **Booster sets drinking water use (DW version), pump has to have Ceramic, Carbon, EPDM seals.**

OPERATING CHARACTERISTICS AND LIMITS

Liquids handled	Water containing no gas or corrosive and/or aggressive substances.
Fluid temperature	Above -10°C a + 80 °C
Ambient temperature	Above 0°C a + 40 °C
Maximum operating pressure	Max 8 bar, 10 bar, 16 bar *
Minimum inlet pressure	According to NPSH curve and losses, with a minimum margin of 0.5 m
Maximum inlet pressure	The inlet pressure added to the pressure of the pump at zero flow must be lower than the maximum operating pressure of the set.
Installation	Indoors, protected from the weather. Away from heat sources. Max elevation 1000 m ASL. Max humidity 50% without condensation.
Hourly starts (single pump)	0,25 kW ≤ Pn ≤ 3 kW max 60 starts per hour. Direct motor start; 4 kW ≤ Pn ≤ 7,5 kW max 40 starts per hour. Direct motor start; 11 kW ≤ Pn ≤ kW max 30 starts per hour. Direct motor start; 18,5 kW ≤ Pn ≤ 22 kW max 24 starts per hour. Direct motor start; 30 kW ≤ Pn ≤ 37 kW max 16 starts per hour. Start/delta start; Pn = 45 kW max 8 starts per hour. Start/delta start;
Sound emission	See table

* On request, PN above in function of the service pump

gfixo_2p-en_c_ti

If there's jockey pump, PN can be lower

SOUND EMISSION LEVELS

50 Hz 2900 rpm		LpA (dB ±2)**	
P2 (kW)	IEC*	G..20	G..30
0,75	90R	<70	<70
1,1	90R	<70	<70
1,5	90	<70	<70
2,2	90	<70	<70
3	90	<70	70
4	112R	70	72
5,5	112	71	73
7,5	132	74	76
9,2	132	76	78
11	132	76	78
15	160	74	76
18,5	160	76	78
22	180R	73	75
30	200	75	77
37	200	75	77
45	225	78	80
55	250	78	80

* R=Reduced motor casing size with respect to shaft extension and related flange.

gfixo_2p-en_b_tr

** Noise value of the electric motor only.

MAIN COMPONENTS

- **Main on-off valves** fitted to the suction and lines of each pump, ball type with threaded connectors up to series FH 50, butterfly type for FH 65 and FH 80 pumps.
- **Check valve** on the delivery side of each pump, spring type with threaded connected up to 2", double-swing type between flanges over 2". For applications with air-cushion autoclaves, the check valves are mounted on the suction side and the unit is fitted with a G 1/2" threaded hose connector for the air supply (GS...RA series).
- **Suction manifold** in AISI 304 stainless steel, threaded or flanged depending on the type of pump (see drawings). Threaded water inlet connector.
- **Delivery manifold** in AISI 304 stainless steel, threaded or flanged depending on the type of pump (see drawings). Threaded R1" connectors with relative caps for connecting expansion vessels.
- **Pressure gauge** and **two control transmitters** located on the delivery side of the unit.
- **Various fittings** in nickel-plated brass, galvanised steel or stainless steel depending on the version.
- **Support base** for pump unit and board bracket in painted steel.
- **Control panel** protected to IP55.

AVAILABLE STANDARD VERSIONS

See material table.

STANDARD VERSION

For general use

Ball valves in nickel-plated brass, butterfly valves in polyamide, check valves in brass or painted cast-iron with flaps in steel, plugs, splines and flanges galvanised steel; manifolds in A304.

DW VERSION (GS../DW)

For use with drinking water

The main components in contact with the fluid are certified for drinking water or made from AISI 304 or superior stainless steel.

Valves in nickel-plated brass, butterfly valves in epoxy, check valves with flaps in AISI 304 steel; manifolds in A304.

AISI 304 VERSION (GS../A304), AISI 316 (GS../A316)

For special uses

The manifolds, valves, check valves and the main elements with parts in direct contact with the fluid are made of AISI 304 or AISI 316 stainless steel.

Optional accessories:

- **Dry-running prevention** devices in one of the following versions:
 - float switch, for positive heads;
 - pack of probe electrodes, for positive heads.
- **Autoclaves** in the following versions:
 - Air-cushion autoclaves with compressor and accessories for autoclave and compressor.
 - Diaphragm autoclaves instead of air-cushion versions.
- **Diaphragm expansion vessel** with ball valve (one for each pump) in the following versions, depending on the maximum head of the pumps:
 - Hydro tube kit 24 L 8 bar
 - Hydro tube kit 24 L 10 bar
 - Hydro tube kit 24 L 16 bar
- **Alarms kit;**
- **Air suction** for RA version;
- **Air compressor** for RA version;

SPECIAL VERSIONS AVAILABLE ON REQUEST

(Contact the Sales and Technical Assistance Service)

- Units with non-standard input voltages, such as three-phase 3x230V, 3x440V.
- Units with single-phase input voltages 1x230V.
- Jockey pump other than the standard ones illustrated in the catalogue.
- Support base in AISI 304, AISI 316 stainless steel.
- Units with stainless steel expansion vessels.
- Units with special valves.
- Units with 4 electric pumps (GS40...).
- Units with 5 electric pumps (GS41... GS50...).
- Units with 6 electric pumps (GS51... GS60...).

TABLE OF MATERIALS FOR SETS WITH FHE 32-40-50 PUMPS

NAME	MATERIAL			
	(STANDARD)	DW	A304	A316
Manifolds	AISI 304	AISI 304	AISI 304	AISI 316
On-off valves	Nickel-plated brass	Nickel-plated brass for drinking water	AISI 304	AISI 316
Non-return valves	AISI 304	AISI 304	AISI 304	AISI 316
Pressure switches	Chrome plated zinc alloy	AISI 304	AISI 304	AISI 304
Pressure transmitters	AISI 316	AISI 316	AISI 316	AISI 316
Nipples/caps/plugs/flanges	Galvanized steel	AISI 316	AISI 316	AISI 316
Bracket	Painted steel	Painted steel	Painted steel	Painted steel
Base	Painted steel	Painted steel	Painted steel	Painted steel
Electric pump body	Painted cast-iron for drinking water	Painted cast-iron for drinking water	Painted cast-iron for drinking water	Painted cast-iron for drinking water

gfixofh_2p-en_a_tm

TABLE OF MATERIALS FOR SETS WITH FHE/FHS 65-80 PUMPS

NAME	MATERIAL			
	(STANDARD)	DW	A304	A316
Manifolds	AISI 304	AISI 304	AISI 304	AISI 316
On-off valves	Polyamide	Polyamide	AISI 304	AISI 316
Non-return valves	Painted cast-iron with stainless steel flaps	Painted cast-iron with stainless steel flaps	AISI 304	AISI 316
Pressure switches	Chrome plated zinc alloy	AISI 304	AISI 304	AISI 304
Pressure transmitters	AISI 316	AISI 316	AISI 316	AISI 316
Nipples/caps/plugs/flanges	Galvanized steel	AISI 316	AISI 316	AISI 316
Bracket	Painted steel	Painted steel	Painted steel	Painted steel
Base	Painted steel	Painted steel	Painted steel	Painted steel
Electric pump body	Painted cast-iron for drinking water	Painted cast-iron for drinking water	Painted cast-iron for drinking water	Painted cast-iron for drinking water

gfixofh65-80_2p-en_a_tm

GS.../FH SERIES BOOSTER SETS HYDRAULIC PERFORMANCE TABLE AT 50 HZ (JOCKEY PUMP)

PUMP TYPE	NOMINAL POWER		Q = DELIVERY											
			l/min	0	12	20	25	30	35	40	45	50	60	73
			m ³ /h	0	0,7	1,2	1,5	1,8	2,1	2,4	2,7	3,0	3,6	4,4
kW		HP	H = TOTAL HEAD METRES COLUMN OF WATER											
3SV02	0,37	0,5	15		14,5	14,3	14,0	13,5	13,0	12,4	11,7	9,8	6,5	
3SV03	0,37	0,5	22		21,2	20,8	20,3	19,6	18,7	17,7	16,6	13,7	8,6	
3SV04	0,37	0,5	29		27,7	27,1	26,2	25,2	23,9	22,5	20,8	16,8	10,1	
3SV05	0,55	0,75	37		36,4	35,8	35,0	33,9	32,6	31,1	29,2	24,5	16,2	
3SV06	0,55	0,75	44		43,4	42,6	41,6	40,2	38,6	36,6	34,3	28,5	18,5	
3SV07	0,75	1	53		51,8	51,0	50,0	48,7	47,0	45,0	42,5	36,1	24,6	
3SV08	0,75	1	60		59,1	58,2	57,0	55,4	53,4	51,0	48,1	40,7	27,5	
3SV09	1,1	1,5	68		66,8	65,8	64,5	62,8	60,6	57,9	54,6	46,4	31,6	
3SV10	1,1	1,5	75		73,8	72,7	71,3	69,3	66,9	63,8	60,2	51,0	34,5	
3SV11	1,1	1,5	82		81,0	79,7	78,0	75,8	73,1	69,7	65,7	55,5	37,4	
3SV12	1,1	1,5	90		87,8	86,4	84,5	82,1	79,1	75,5	71,1	59,9	40,1	
3SV13	1,5	2	98		96,7	95,4	93,5	91,0	87,8	83,9	79,2	67,2	45,6	
3SV14	1,5	2	106		104,1	102,5	100,4	97,7	94,2	89,9	84,8	71,8	48,5	
3SV16	1,5	2	120		117,8	116,1	113,6	110,5	106,5	101,6	95,8	80,9	54,2	
3SV19	2,2	3	144		142,3	140,3	137,5	133,9	129,2	123,5	116,7	99,1	67,6	
3SV21	2,2	3	159		157	155	151	147	142	136	128	108	74	

gfix_fhe_pp_3sv-2p50-en_b_th

PUMP TYPE	NOMINAL POWER		Q = DELIVERY										
			l/min	0	30	40	50	60	70	80	100	120	150
			m ³ /h	0	1,8	2,4	3	3,6	4,2	4,8	6	7,2	9
kW		HP	H = TOTAL HEAD METRES COLUMN OF WATER										
CA 70/33	0,75	1	42,9	38,8	36,9	34,6	31,7	28,2	23,9				
CA 70/34	0,9	1,2	48,8	45,1	43,2	40,7	37,7	34,0	29,5				
CA 70/45	1,1	1,5	56,2	52,0	49,8	47,1	43,9	39,9	35,3				
CA 120/55	2,2	3	63,8			59,6	58,2	56,6	54,8	50,6	45,7	37,1	

Performance according to ISO 9906 - Annex A.

9490_pp_ca-2p50-en_a_th

GS20/FH 32-40, GS21/FH 32-40 SERIES BOOSTER SETS HYDRAULIC PERFORMANCE TABLE AT 50 HZ (SERVICE PUMP)

PUMP TYPE	NOMINAL POWER kW	Q = DELIVERY													
		l/min 0	200	300	500	600	800	900	1200	1400	1600	1800	2400	2800	3000
		m ³ /h 0	12	18	30	36	48	54	72	84	96	108	144	168	180
		H = TOTAL HEAD METRES COLUMN OF WATER													
FHE 32-125/07	2 x 0,75	16,9		14,6	11,0	8,7									
FHE 32-125/11	2 x 1,1	21,9		19,6	16,3	14,2	9,0								
FHE 32-160/15	2 x 1,5	27,3		24,5	20,5	17,8	11,0								
FHE 32-160/22	2 x 2,2	34,7		32,0	28,0	25,3	18,8	15,0							
FHE 32-200/30	2 x 3	44,2		39,8	35,2	32,2	24,6	19,8							
FHE 32-200/40	2 x 4	54,4		50,0	45,0	41,9	34,6	30,3							
2FHE 32-250/55	2 x 5,5	79,0	74,7	71,0	62,0	56,0	37,0								
2FHE 32-250/75	2 x 7,5	99,0	95,3	92,0	83,0	76,0	58,0								
FHE 40-125/11	2 x 1,1	14,5				13,0	11,3	10,1	5,8						
FHE 40-125/15	2 x 1,5	18,1				16,7	15,0	13,9	9,6	6,0					
FHE 40-125/22	2 x 2,2	24,5				23,0	21,0	20,1	15,8	12,3	8,2				
FHE 40-160/30	2 x 3	31,5				29,4	27,5	26,1	21,5	17,4					
FHE 40-160/40	2 x 4	38,0				36,2	34,0	33,0	28,5	24,5	20,1				
FHE 40-200/55	2 x 5,5	46,5				44,0	41,5	40,2	34,5	29,5					
FHE 40-200/75	2 x 7,5	57,0				54,0	52,0	50,0	45,5	41,0	36,1				
FHE 40-250/92	2 x 9,2	64,0				59,0	56,0	55,0	49,0	45,0	39,5				
FHE 40-250/110	2 x 11	72,0				67,5	65,0	63,0	57,0	52,0	47,0				
FHE 40-250/150	2 x 15	85,0				80,0	77,0	75,0	70,0	65,0	60,0				

The table refers to performance with 2 pumps running.

gfix_fhe32-40_2p-2p50-en_c_th

GS20/FH 50-80, GS21/FH 50-80 SERIES BOOSTER SETS HYDRAULIC PERFORMANCE TABLE AT 50 HZ (SERVICE PUMP)

PUMP TYPE	NOMINAL POWER kW	Q = DELIVERY															
		l/min 0	800	900	1200	1400	1600	1800	2400	2800	3000	3600	4000	4600	6000	7000	
		m ³ /h 0	48	54	72	84	96	108	144	168	180	216	240	276	360	420	
		H = PREVALENZA TOTALE IN METRI COLONNA ACQUA															
FHE 50-125/22	2 x 2,2	17,0			15,1	14,0	12,8	11,4	6,2								
FHE 50-125/30	2 x 3	20,0			18,8	18,0	16,9	15,6	10,5								
FHE 50-125/40	2 x 4	24,0			23,1	22,5	21,5	20,3	15,8	11,8							
FHE 50-160/55	2 x 5,5	32,0			30,6	29,5	28,0	26,6	20,5	14,8							
FHE 50-160/75	2 x 7,5	40,0			38,0	37,0	36,0	34,4	29,0	24,0	21,0						
FHE 50-200/92	2 x 9,2	50,5			46,8	45,0	43,0	40,9	32,5	25,7							
FHE 50-200/110	2 x 11	58,0			54,0	53,0	50,0	48,3	40,0	33,0	29,0						
FHE 50-250/150	2 x 15	68,0			64,0	63,0	61,0	59,0	50,0	41,0							
FHE 50-250/185	2 x 18,5	77,0			73,0	72,0	70,0	68,0	60,0	52,0	47,0						
FHE 50-250/220	2 x 22	86,0			82,5	81,0	80,0	78,0	70,0	61,0	57,0						
FHE 65-125/40	2 x 4	19,0					17,3	16,8	14,5	13,0	11,8						
FHE 65-125/55	2 x 5,5	23,0					21,3	20,9	19,0	17,5	16,7	13,7					
FHE 65-125/75	2 x 7,5	27,0					26,0	25,6	24,5	23,0	22,5	20,0	18,0				
FHE 65-160/92	2 x 9,2	33,0						31,5	30,0	28,0	27,1	24,0	21,5				
FHE 65-160/110	2 x 11	36,0						34,5	33,0	31,5	30,8	28,0	25,5				
FHE 65-160/150	2 x 15	42,0						41,0	40,0	38,5	37,8	35,0	33,0	29,5			
FHE 65-200/150	2 x 15	45,0						45,5	43,0	41,0	40,2	36,5	34,0				
FHE 65-200/185	2 x 18,5	52,0						52,0	51,0	49,0	48,0	44,5	42,0				
FHE 65-200/220	2 x 22	59,0						59,5	58,0	56,0	55,0	52,0	49,5	44,5			
FHE 65-250/220	2 x 22	62,0						61,0	58,0	56,0	54,0	48,5	44,0				
FHS65-250/300	2 x 30	76,0						74,5	73,0	70,5	69,0	64,0	61,0	54,0			
FHS65-250/370	2 x 37	90,0						88,0	86,0	84,0	82,5	78,0	74,5	68,0			
FHE80-160/110	2 x 11	27,0										27,3	26,0	24,5	22,5	16,0	
FHE80-160/150	2 x 15	33,0										32,5	31,0	30,0	28,0	22,0	16,5
FHE80-160/185	2 x 18,5	39,0										38,0	36,5	35,5	34,0	28,5	23,3
FHE80-200/220	2 x 22	48,0										47,0	45,0	43,5	41,0	32,5	24,5
FHS80-200/300	2 x 30	60,0										59,5	58,0	57,0	54,5	47,0	40,5
FHS80-250/370	2 x 37	71,0										70,0	67,0	65,0	61,0	49,0	38,0
FHS80-250/450	2 x 45	80,0										80,5	78,0	76,0	72,5	62,0	51,4
FHS80-250/550	2 x 55	92,0										93,0	91,0	89,5	86,5	77,0	68,4

The table refers to performance with 2 pumps running.

gms_2p50-80_2p50-en_b_th

GS30/FH 32-40 SERIES BOOSTER SETS HYDRAULIC PERFORMANCE TABLE AT 50 HZ (SERVICE PUMP)

PUMP TYPE	NOMINAL POWER kW	Q = DELIVERY													
		l/min 0	300	450	750	900	1200	1350	1800	2100	2400	2700	3600	4200	4500
		m ³ /h 0	18	27	45	54	72	81	108	126	144	162	216	252	270
H = PREVALENZA TOTALE IN METRI COLONNA ACQUA															
FHE 32-125/07	3 x 0,75	16,9		14,6	11,0	8,7									
FHE 32-125/11	3 x 1,1	21,9		19,6	16,3	14,2	9,0								
FHE 32-160/15	3 x 1,5	27,3		24,5	20,5	17,8	11,0								
FHE 32-160/22	3 x 2,2	34,7		32,0	28,0	25,3	18,8	15,0							
FHE 32-200/30	3 x 3	44,2		39,8	35,2	32,2	24,6	19,8							
FHE 32-200/40	3 x 4	54,4		50,0	45,0	41,9	34,6	30,3							
2FHE 32-250/55	3 x 5,5	79,0	74,7	71,0	62,0	56,0	37,0								
2FHE 32-250/75	3 x 7,5	99,0	95,3	92,0	83,0	76,0	58,0								
FHE 40-125/11	3 x 1,1	14,5				13,0	11,3	10,1	5,8						
FHE 40-125/15	3 x 1,5	18,1				16,7	15,0	13,9	9,6	6,0					
FHE 40-125/22	3 x 2,2	24,5				23,0	21,0	20,1	15,8	12,3	8,2				
FHE 40-160/30	3 x 3	31,5				29,4	27,5	26,1	21,5	17,4					
FHE 40-160/40	3 x 4	38,0				36,2	34,0	33,0	28,5	24,5	20,1				
FHE 40-200/55	3 x 5,5	46,5				44,0	41,5	40,2	34,5	29,5					
FHE 40-200/75	3 x 7,2	57,0				54,0	52,0	50,0	45,5	41,0	36,1				
FHE 40-250/92	3 x 9,2	64,0				59,0	56,0	55,0	49,0	45,0	39,5				
FHE 40-250/110	3 x 11	72,0				67,5	65,0	63,0	57,0	52,0	47,0				
FHE 40-250/150	3 x 15	85,0				80,0	77,0	75,0	70,0	65,0	60,0				

The table refers to performance with 3 pumps running.

gfix_fhe32-40_3p-2p50-en_c_th

GS30/FH 50-80 SERIES BOOSTER SETS HYDRAULIC PERFORMANCE TABLE AT 50 HZ (SERVICE PUMP)

PUMP TYPE	NOMINAL POWER kW	Q = DELIVERY															
		l/min 0	1200	1350	1800	2100	2400	2700	3600	4200	4500	5400	6000	6900	9000	10500	
		m ³ /h 0	72	81	108	126	144	162	216	252	270	324	360	414	540	630	
H = PREVALENZA TOTALE IN METRI COLONNA ACQUA																	
FHE 50-125/22	3 x 2,2	17,0			15,1	14,0	12,8	11,4	6,2								
FHE 50-125/30	3 x 3	20,0			18,8	18,0	16,9	15,6	10,5								
FHE 50-125/40	3 x 4	24,0			23,1	22,5	21,5	20,3	15,8	11,8							
FHE 50-160/55	3 x 5,5	32,0			30,6	29,5	28,0	26,6	20,5	14,8							
FHE 50-160/75	3 x 7,5	40,0			38,0	37,0	36,0	34,4	29,0	24,0	21,0						
FHE 50-200/92	3 x 9,2	50,5			46,8	45,0	43,0	40,9	32,5	25,7							
FHE 50-200/110	3 x 11	58,0			54,0	53,0	50,0	48,3	40,0	33,0	29,0						
FHE 50-250/150	3 x 15	68,0			64,0	63,0	61,0	59,0	50,0	41,0							
FHE 50-250/185	3 x 18,5	77,0			73,0	72,0	70,0	68,0	60,0	52,0	47,0						
FHE 50-250/220	3 x 22	86,0			82,5	81,0	80,0	78,0	70,0	61,0	57,0						
FHE 65-125/40	3 x 4	19,0					17,3	16,8	14,5	13,0	11,8						
FHE 65-125/55	3 x 5,5	23,0					21,3	20,9	19,0	17,5	16,7	13,7					
FHE 65-125/75	3 x 7,5	27,0					26,0	25,6	24,5	23,0	22,5	20,0	18,0				
FHE 65-160/92	3 x 9,2	33,0						31,5	30,0	28,0	27,1	24,0	21,5				
FHE 65-160/110	3 x 11	36,0						34,5	33,0	31,5	30,8	28,0	25,5				
FHE 65-160/150	3 x 15	42,0						41,0	40,0	38,5	37,8	35,0	33,0	29,5			
FHE 65-200/150	3 x 15	45,0						45,5	43,0	41,0	40,2	36,5	34,0				
FHE 65-200/185	3 x 18,5	52,0						52,0	51,0	49,0	48,0	44,5	42,0				
FHE 65-200/220	3 x 22	59,0						59,5	58,0	56,0	55,0	52,0	49,5	44,5			
FHE 65-250/220	3 x 22	62,0						61,0	58,0	56,0	54,0	48,5	44,0				
FHS65-250/300	3 x 30	76,0						74,5	73,0	70,5	69,0	64,0	61,0	54,0			
FHS65-250/370	3 x 37	90,0						88,0	86,0	84,0	82,5	78,0	74,5	68,0			
FHE80-160/110	3 x 11	27,0										27,3	26,0	24,5	22,5	16,0	
FHE80-160/150	3 x 15	33,0										32,5	31,0	30,0	28,0	22,0	16,5
FHE80-160/185	3 x 18,5	39,0										38,0	36,5	35,5	34,0	28,5	23,3
FHE80-200/220	3 x 22	48,0										47,0	45,0	43,5	41,0	32,5	24,5
FHS80-200/300	3 x 30	60,0										59,5	58,0	57,0	54,5	47,0	40,5
FHS80-250/370	3 x 37	71,0										70,0	67,0	65,0	61,0	49,0	38,0
FHS80-250/450	3 x 45	80,0										80,5	78,0	76,0	72,5	62,0	51,4
FHS80-250/550	3 x 55	92,0										93,0	91,0	89,5	86,5	77,0	68,4

The table refers to performance with 3 pumps running.

gms_3p50-80_2p50-en_b_th

GS.../FH

GS20, GS21, GS30/FH SERIES BOOSTER SETS ELECTRICAL DATA TABLE AT 50 Hz

SERVICE PUMP 3 X 400 V			JOCKEY PUMP 3 X 400 V			CURRENT ABSORBED BY SET 3 X 400V		
TYPE	Pn kW	In A	TYPE	Pn kW	In A	GS20 A	GS21 A	GS30 A
FHE 32-125/07	0,75	1,70	CA70/33	0,75	1,87	3,40	5,27	5,10
FHE 32-125/11	1,1	2,39	CA70/33	0,75	1,87	4,78	6,65	7,17
FHE 32-160/15	1,5	3,17	CA70/33	0,75	1,87	6,34	8,21	9,51
FHE 32-160/22	2,2	4,64	CA70/33	0,75	1,87	9,28	11,15	13,92
FHE 32-200/30	3	6,14	CA70/34	0,9	2,37	12,28	14,65	18,42
FHE 32-200/40	4	7,63	CA70/45	1,1	2,83	15,26	18,09	22,89
2FHE 32-250/55	5,5	10,4	3SV11	1,1	2,39	20,80	23,19	31,20
2FHE 32-250/75	7,5	14,0	3SV13	1,5	3,17	28,00	31,17	42,00
FHE 40-125/11	1,1	2,39	CA70/33	0,75	1,87	4,78	6,65	7,17
FHE 40-125/15	1,5	3,17	CA70/33	0,75	1,87	6,34	8,21	9,51
FHE 40-125/22	2,2	4,64	CA70/33	0,75	1,87	9,28	11,15	13,92
FHE 40-160/30	3	6,14	CA70/33	0,75	1,87	12,28	14,15	18,42
FHE 40-160/40	4	7,63	CA70/33	0,75	1,87	15,26	17,13	22,89
FHE 40-200/55	5,5	10,4	CA70/34	0,9	2,37	20,80	23,17	31,20
FHE 40-200/75	7,5	14,0	CA70/45	1,1	2,83	28,00	30,83	42,00
FHE 40-250/92	9,2	16,8	CA120/55	1,85	4,65	33,60	38,25	50,40
FHE 40-250/110	11	20,3	3SV10	1,1	2,39	40,60	42,99	60,90
FHE 40-250/150	15	26,0	3SV12	1,1	2,39	52,00	54,39	78,00
FHE 50-125/22	2,2	4,64	CA70/33	0,75	1,87	9,28	11,15	13,92
FHE 50-125/30	3	6,14	CA70/33	0,75	1,87	12,28	14,15	18,42
FHE 50-125/40	4	7,63	CA70/33	0,75	1,87	15,26	17,13	22,89
FHE 50-160/55	5,5	10,4	CA70/33	0,75	1,87	20,80	22,67	31,20
FHE 50-160/75	7,5	14,0	CA70/33	0,75	1,87	28,00	29,87	42,00
FHE 50-200/92	9,2	16,8	CA70/45	1,1	2,83	33,60	36,43	50,40
FHE 50-200/110	11	20,3	CA120/55	1,85	4,65	40,60	45,25	60,90
FHE 50-250/150	15	26,0	3SV10	1,1	2,39	52,00	54,39	78,00
FHE 50-250/185	18,5	33,2	3SV11	1,1	2,39	66,40	68,79	99,60
FHE 50-250/220	22	38,6	3SV12	1,1	2,39	77,20	79,59	115,80
FHE 65-125/40	4	7,63	CA70/33	0,75	1,87	15,26	17,13	22,89
FHE 65-125/55	5,5	10,4	CA70/33	0,75	1,87	20,80	22,67	31,20
FHE 65-125/75	7,5	14,0	CA70/33	0,75	1,87	28,00	29,87	42,00
FHE 65-160/92	9,2	16,8	CA70/33	0,75	1,87	33,60	35,47	50,40
FHE 65-160/110	11	20,3	CA70/33	0,75	1,87	40,60	42,47	60,90
FHE 65-160/150	15	26,0	CA70/33	0,75	1,87	52,00	53,87	78,00
FHE 65-200/150	15	26,0	CA70/34	0,9	2,37	52,00	54,37	78,00
FHE 65-200/185	18,5	33,2	CA70/45	1,1	2,83	66,40	69,23	99,60
FHE 65-200/220	22	38,6	CA120/55	1,85	4,65	77,20	81,85	115,80
FHE 65-250/220	22	38,6	CA120/55	1,85	4,65	77,20	81,85	115,80
FHS65-250/300	30	53,6	3SV11	1,1	2,39	107,20	109,59	160,80
FHS65-250/370	37	65,8	3SV13	1,5	3,17	131,60	134,77	197,40
FHE80-160/110	11	20,3	CA70/33	0,75	1,87	40,60	42,47	60,90
FHE80-160/150	15	26,0	CA70/33	0,75	1,87	52,00	53,87	78,00
FHE80-160/185	18,5	33,2	CA70/33	0,75	1,87	66,40	68,27	99,60
FHE80-200/220	22	38,6	CA70/34	0,9	2,37	77,20	79,57	115,80
FHS80-200/300	30	53,6	CA120/55	1,85	4,65	107,20	111,85	160,80
FHS80-250/370	37	65,8	3SV10	1,1	2,39	131,60	133,99	197,40
FHS80-250/450	45	78,0	3SV11	1,1	2,39	156,00	158,39	234,00
FHS80-250/550	55	95,0	3SV13	1,5	3,17	190,00	193,17	285,00

The current shown is the nominal current of the set.

gms_fhes_2p50-en_e_te

Booster sets

MARKET SECTORS CIVIL, INDUSTRIAL

APPLICATIONS

- Water network supply in condominiums, offices, hotels, shopping centres, factories.
- Water supply to agricultural water networks (e.g. irrigation).

GSD20 - GSY20 Series

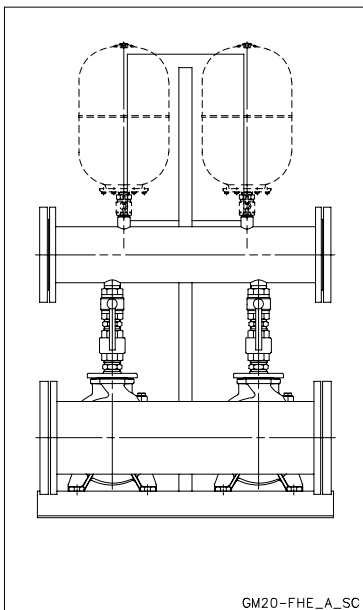

SPECIFICATIONS

- **Flow rate** up to 420 m³/h.
- **Head** up to 100 m.
- Electrical panel supply voltage: 3 x 400V ± 10%.
- Frequency 50 Hz.
- Voltage for controls outside panel: 24 Vac.
- Electrical panel protection class IP 55.
- Maximum service pump power: 2 x 55 kW.
- **Motor start-up:**
 - Direct for powers up to 22 kW inclusive for pump (GSD/).
 - Star/Delta for higher powers (GSY/ set).
 - Softstarter, available on request (GSR../ set).
- **Electric pumps with horizontal axis:**
 - FH series (motor protection class IP55).
- Maximum operating pressure: 16 bar.
- Maximum temperature of pumped liquid : +80°C.

**TWO-PUMP BOOSTER SETS, GSD20-GSY20 SERIES
HORIZONTAL ELECTRIC PUMPS WITH NON-RETURN VALVE
ON DISCHARGE SIDE**

1

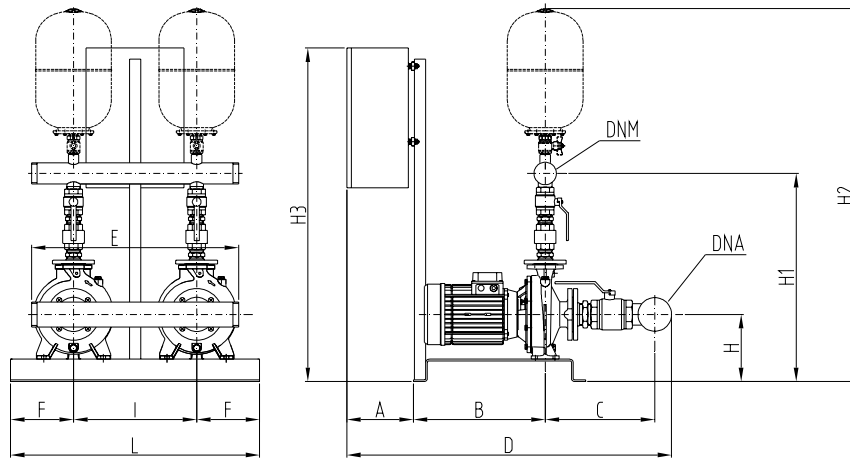

GS20_FHE32_A_DD

2

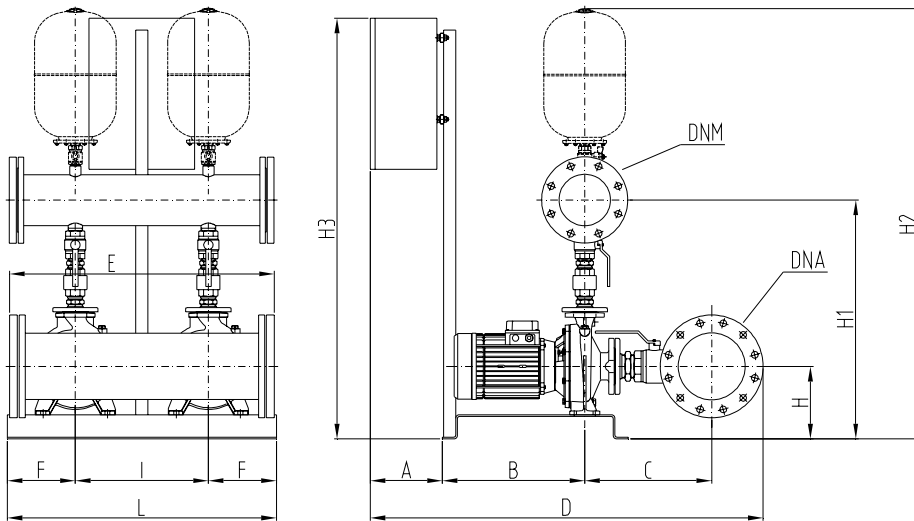

GS20_FHE_A_DD

3

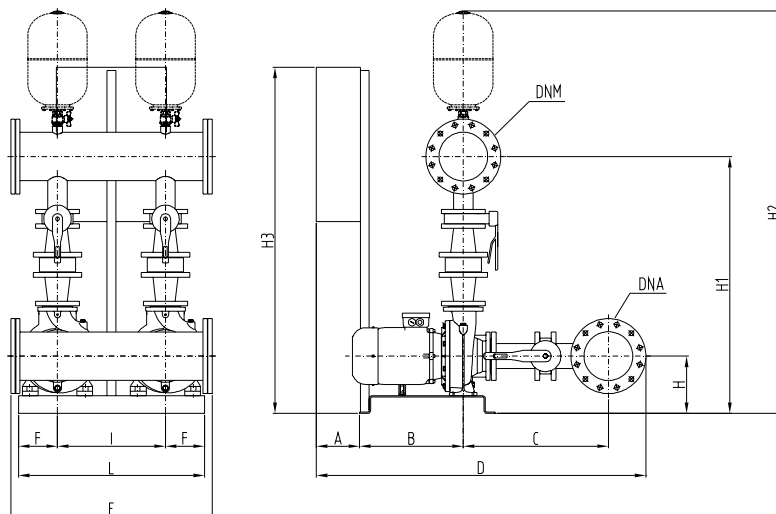

GS20_FHE65_A_DD

TWO-PUMP BOOSTER SETS, GSD20-GSY20 SERIES HORIZONTAL ELECTRIC PUMPS WITH NON-RETURN VALVE ON DISCHARGE SIDE

GSD20 / GSY20	DRW N°	DNA	DNM	A	B	C	D	E	F	H	H1	H2	H3	I	L
FHE 32-125/07	1	80	65	194	303	305	846	722	135	192	601	1189	1016	370	640
FHE 32-125/11	1	80	65	194	303	305	846	722	135	192	601	1189	1016	370	640
FHE 32-160/15	1	80	65	194	303	305	846	722	135	212	641	1229	1016	370	640
FHE 32-160/22	1	80	65	194	303	305	846	722	135	212	641	1229	1016	370	640
FHE 32-200/30	1	80	65	194	303	305	846	722	135	240	689	1277	1016	370	640
FHE 32-200/40	1	80	65	194	303	305	846	722	135	240	689	1277	1016	370	640
2FHE 32-250/55	1	80	65	194	300	362	900	722	135	240	704	1292	973	370	640
2FHE 32-250/75	1	80	65	194	300	362	900	722	135	240	704	1292	973	370	640
FHE 40-125/11	2	100	100	196	471	332	1109	842	200	192	659	1266	1017	490	890
FHE 40-125/15	2	100	100	194	471	332	1107	842	200	192	659	1266	1017	490	890
FHE 40-125/22	2	100	100	194	471	332	1107	842	200	192	659	1266	1017	490	890
FHE 40-160/30	2	100	100	194	471	332	1107	842	200	212	699	1306	1017	490	890
FHE 40-160/40	2	100	100	194	471	332	1107	842	200	212	699	1306	1017	490	890
FHE 40-200/55	2	100	100	194	471	352	1127	842	200	240	747	1354	974	490	890
FHE 40-200/75	2	100	100	194	471	352	1127	842	200	240	747	1354	974	490	890
FHE 40-250/92	2	100	100	194	471	352	1127	842	200	260	812	1419	974	490	890
FHE 40-250/110	2	100	100	194	471	352	1127	842	200	260	812	1419	974	490	890
FHE 40-250/150	2	100	100	244	568	352	1274	842	200	260	812	1419	1121	490	890
FHE 50-125/22	2	150	125	196	471	379	1189	842	200	212	737	1357	1017	490	890
FHE 50-125/30	2	150	125	196	471	379	1189	842	200	212	737	1357	1017	490	890
FHE 50-125/40	2	150	125	196	471	379	1189	842	200	212	737	1357	1017	490	890
FHE 50-160/55	2	150	125	196	471	379	1189	842	200	240	785	1405	974	490	890
FHE 50-160/75	2	150	125	196	471	379	1189	842	200	240	785	1405	974	490	890
FHE 50-200/92	2	150	125	196	471	379	1189	842	200	240	805	1425	974	490	890
FHE 50-200/110	2	150	125	196	471	379	1189	842	200	240	805	1425	974	490	890
FHE 50-250/150	2	150	125	246	568	379	1336	842	200	260	850	1470	1121	490	890
FHE 50-250/185	2	150	125	235	815	379	1572	842	365	300	890	1510	1121	490	1220
FHE 50-250/220	2	150	125	285	815	379	1622	842	365	300	890	1510	1571	490	1220
FHE65-125/40	3	200	150	196	471	589	1426	922	200	240	1034	1668	1017	490	890
FHE65-125/55	3	200	150	196	471	589	1426	922	200	240	1034	1668	974	490	890
FHE65-125/75	3	200	150	196	471	589	1426	922	200	240	1034	1668	974	490	890
FHE65-160/92	3	200	150	196	471	589	1426	922	200	240	1054	1688	974	490	890
FHE65-160/110	3	200	150	196	471	589	1426	922	200	240	1054	1688	974	490	890
FHE65-160/150	3	200	150	246	568	589	1573	922	200	240	1054	1688	1121	490	890
FHE65-200/150	3	200	150	246	568	589	1573	922	200	260	1099	1733	1121	490	890
FHE65-200/185	3	200	150	235	815	589	1809	922	365	300	1139	1773	1121	490	1220
FHE65-200/220	3	200	150	285	815	589	1859	922	365	300	1139	1773	1571	490	1220
FHE65-250/220	3	200	150	285	815	589	1859	922	365	320	1184	1818	1571	490	1220
FHS65-250/300	3	200	150	285	915	589	1959	922	365	320	1184	1818	1571	490	1220
FHS65-250/370	3	200	150	285	915	589	1959	922	365	320	1184	1818	1571	490	1220
FHE80-160/110	3	250	200	196	471	687	1556	982	200	260	1166	1825	974	490	890
FHE80-160/150	3	250	200	246	568	687	1703	982	200	260	1166	1825	1121	490	890
FHE80-160/185	3	250	200	235	815	687	1939	982	365	300	1206	1865	1121	490	1220
FHE80-200/220	3	250	200	285	815	687	1989	982	365	300	1231	1890	1571	490	1220
FHS80-200/300	3	250	200	285	915	687	2089	982	365	320	1251	1910	1571	490	1220
FHS80-250/370	3	250	200	285	915	687	2089	982	365	320	1281	1940	1571	490	1220
FHS80-250/450	DIMENSIONS ON REQUEST														
FHS80-250/550	DIMENSIONS ON REQUEST														

Dimensions in mm. Tolerance ± 10 mm.

gs20_fhe-en_b_td

**TWO-PUMP BOOSTER SETS, GSD20-GSY20 RA SERIES
HORIZONTAL ELECTRIC PUMPS WITH NON-RETURN VALVE
ON SUCTION SIDE**

GS.../FH

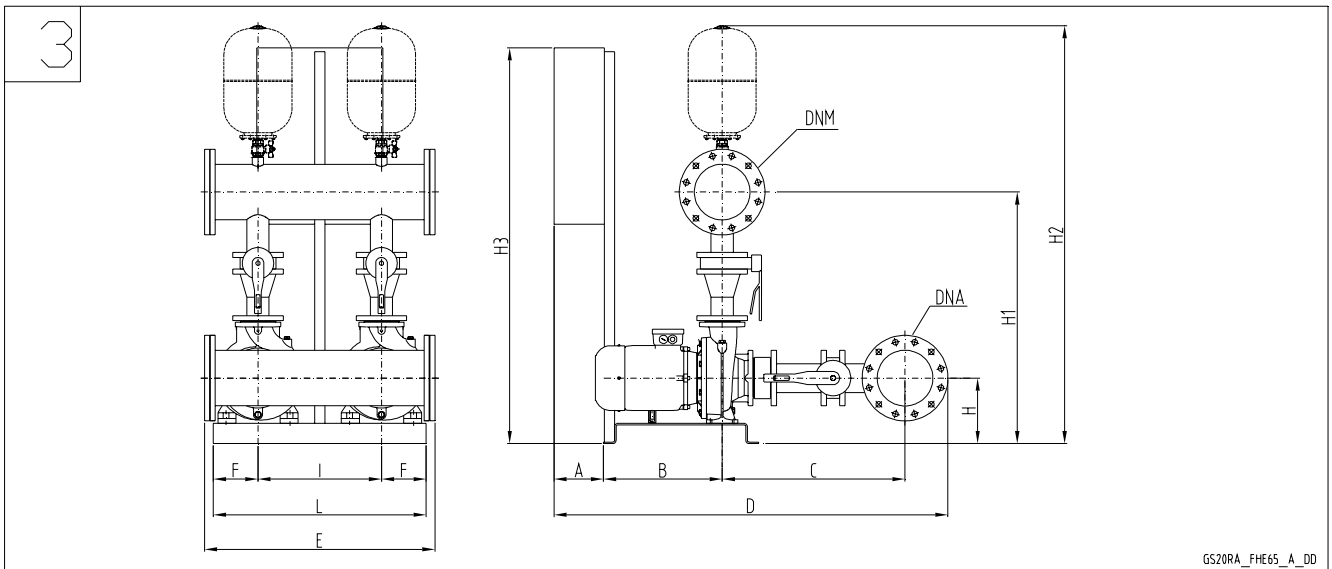
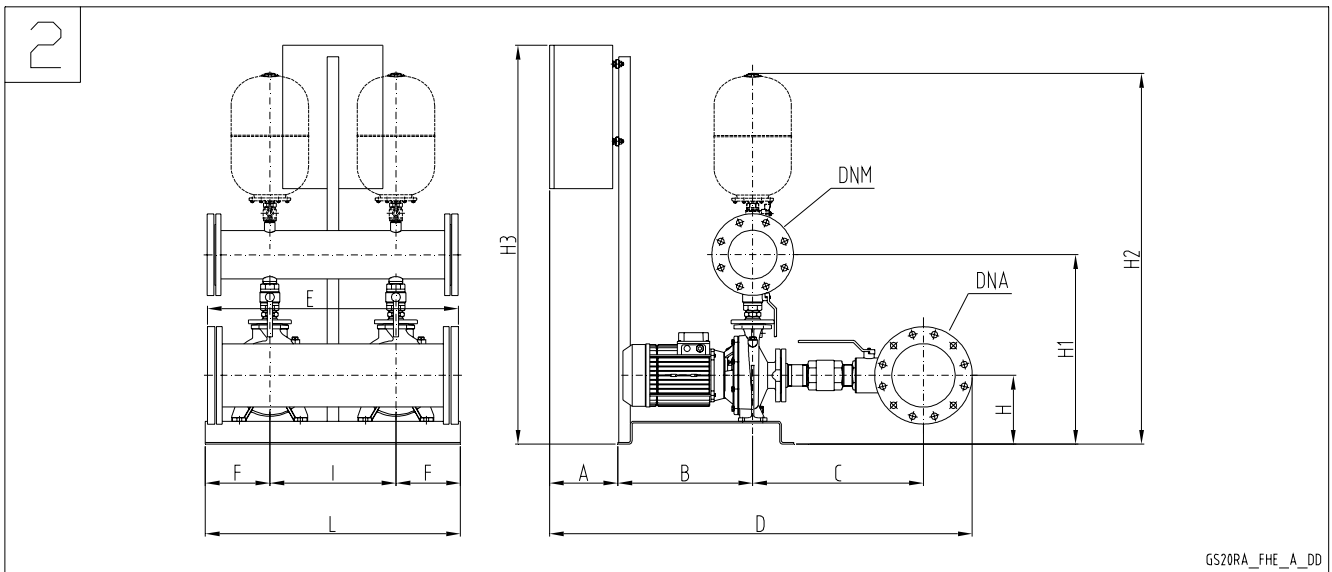
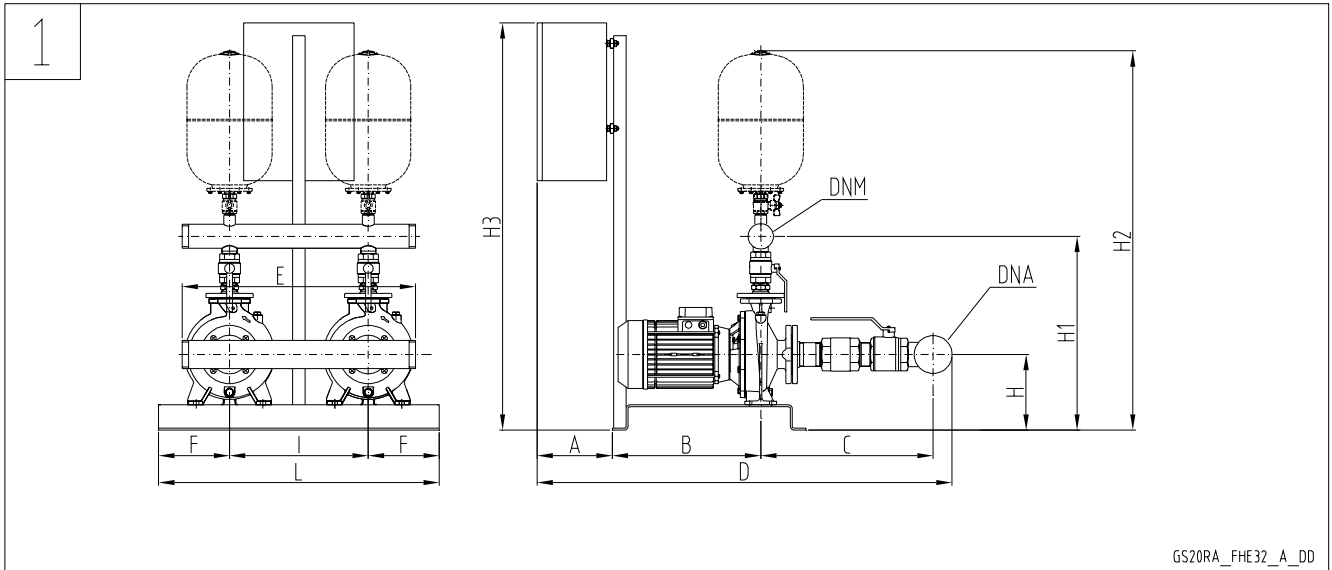

**TWO-PUMP BOOSTER SETS, GSD20-GSY20 RA SERIES
HORIZONTAL ELECTRIC PUMPS WITH NON-RETURN VALVE
ON SUCTION SIDE**

GSD20 / GSY20RA	DRW N°	DNA	DNM	A	B	C	D	E	F	H	H1	H2	H3	I	L
FHE 32-125/07	1	80	65	194	303	425	966	722	135	192	496	1084	1016	370	640
FHE 32-125/11	1	80	65	194	303	425	966	722	135	192	496	1084	1016	370	640
FHE 32-160/15	1	80	65	194	303	425	966	722	135	212	536	1124	1016	370	640
FHE 32-160/22	1	80	65	194	303	425	966	722	135	212	536	1124	1016	370	640
FHE 32-200/30	1	80	65	194	303	425	966	722	135	240	584	1172	1016	370	640
FHE 32-200/40	1	80	65	194	303	425	966	722	135	240	584	1172	1016	370	640
2FHE 32-250/55	1	80	65	194	300	441	979	722	135	240	583	1171	973	370	640
2FHE 32-250/75	1	80	65	194	300	441	979	722	135	240	583	1171	973	370	640
FHE 40-125/11	2	100	100	196	471	514	1291	842	200	192	548	1155	1017	490	890
FHE 40-125/15	2	100	100	194	471	514	1289	842	200	192	548	1155	1017	490	890
FHE 40-125/22	2	100	100	194	471	514	1289	842	200	192	548	1155	1017	490	890
FHE 40-160/30	2	100	100	194	471	514	1289	842	200	212	588	1195	1017	490	890
FHE 40-160/40	2	100	100	194	471	514	1289	842	200	212	588	1195	1017	490	890
FHE 40-200/55	2	100	100	194	471	534	1309	842	200	240	636	1243	974	490	890
FHE 40-200/75	2	100	100	194	471	534	1309	842	200	240	636	1243	974	490	890
FHE 40-250/92	2	100	100	194	471	534	1309	842	200	260	701	1308	974	490	890
FHE 40-250/110	2	100	100	194	471	534	1309	842	200	260	701	1308	974	490	890
FHE 40-250/150	2	100	100	244	568	534	1456	842	200	260	701	1308	1121	490	890
FHE 50-125/22	2	150	125	196	471	561	1371	842	200	212	624	1244	1017	490	890
FHE 50-125/30	2	150	125	196	471	561	1371	842	200	212	624	1244	1017	490	890
FHE 50-125/40	2	150	125	196	471	561	1371	842	200	212	624	1244	1017	490	890
FHE 50-160/55	2	150	125	196	471	561	1371	842	200	240	672	1292	974	490	890
FHE 50-160/75	2	150	125	196	471	561	1371	842	200	240	672	1292	974	490	890
FHE 50-200/92	2	150	125	196	471	561	1371	842	200	240	692	1312	974	490	890
FHE 50-200/110	2	150	125	196	471	561	1371	842	200	240	692	1312	974	490	890
FHE 50-250/150	2	150	125	246	568	561	1518	842	200	260	737	1357	1121	490	890
FHE 50-250/185	2	150	125	235	815	561	1754	842	365	300	777	1397	1121	490	1220
FHE 50-250/220	2	150	125	285	815	561	1804	842	365	300	777	1397	1571	490	1220
FHE65-125/40	3	200	150	196	471	649	1486	922	200	240	908	1542	1017	490	890
FHE65-125/55	3	200	150	196	471	649	1486	922	200	240	908	1542	974	490	890
FHE65-125/75	3	200	150	196	471	649	1486	922	200	240	908	1542	974	490	890
FHE65-160/92	3	200	150	196	471	649	1486	922	200	240	928	1562	974	490	890
FHE65-160/110	3	200	150	196	471	649	1486	922	200	240	928	1562	974	490	890
FHE65-160/150	3	200	150	246	568	649	1633	922	200	240	928	1562	1121	490	890
FHE65-200/150	3	200	150	246	568	649	1633	922	200	260	973	1607	1121	490	890
FHE65-200/185	3	200	150	235	815	649	1869	922	365	300	1013	1647	1121	490	1220
FHE65-200/220	3	200	150	285	815	649	1919	922	365	300	1013	1647	1571	490	1220
FHE65-250/220	3	200	150	285	815	649	1919	922	365	320	1058	1692	1571	490	1220
FHS65-250/300	3	200	150	285	915	649	2019	922	365	320	1058	1692	1571	490	1220
FHS65-250/370	3	200	150	285	915	649	2019	922	365	320	1058	1692	1571	490	1220
FHE80-160/110	3	250	200	196	471	754	1623	982	200	260	999	1658	974	490	890
FHE80-160/150	3	250	200	246	568	754	1770	982	200	260	999	1658	1121	490	890
FHE80-160/185	3	250	200	235	815	754	2006	982	365	300	1039	1698	1121	490	1220
FHE80-200/220	3	250	200	285	815	754	2056	982	365	300	1064	1723	1571	490	1220
FHS80-200/300	3	250	200	285	915	754	2156	982	365	320	1084	1743	1571	490	1220
FHS80-250/370	3	250	200	285	915	754	2156	982	365	320	1114	1773	1571	490	1220
FHS80-250/450															
FHS80-250/550															

Dimensions in mm. Tolerance \pm 10 mm.

gs20ra_fhe-en_b_td

GS.../FH

Booster sets

MARKET SECTORS CIVIL, INDUSTRIAL

APPLICATIONS

- Water network supply in condominiums, offices, hotels, shopping centres, factories.
- Water supply to agricultural water networks (e.g. irrigation).

GSD21 - GSY21 Series

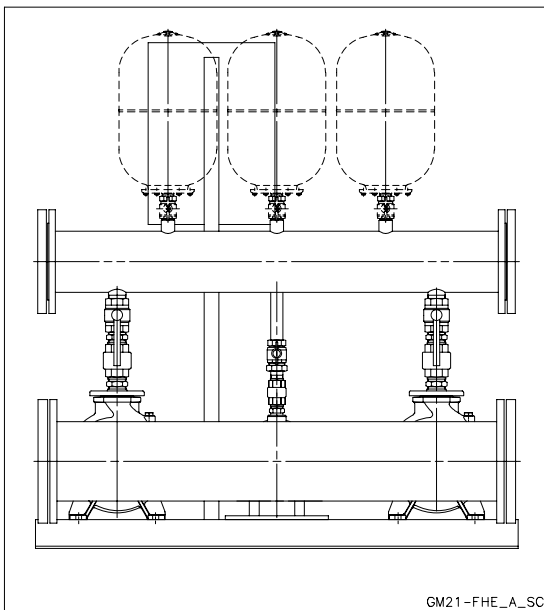

SPECIFICATIONS

- **Flow rate** up to 420 m³/h.
- **Head** up to 100 m.
- Electrical panel supply voltage: 3 x 400V ± 10%.
- Frequency 50 Hz.
- Voltage for controls outside panel: 24 Vac.
- Electrical panel protection class IP 55.
- Maximum service pump power: 2 x 55 kW.
- **Motor start-up:**
 - Direct for powers up to 22 kW inclusive for pump (GSD/).
 - Star/Delta for higher powers (GSY/ set).
 - Softstarter, available on request (GSR../ set).
- **Electric pumps with horizontal axis:**
 - FH series (motor protection class IP55).
- **Electric jockey pumps**
 - SV and CA series (motor protection class IP55).
- Maximum operating pressure: 16 bar.
- Maximum temperature of pumped liquid : +80°C.

**TWO-PUMP BOOSTER SETS, GSD21 SERIES
HORIZONTAL ELECTRIC PUMPS WITH JOCKEY PUMP
NON-RETURN VALVE ON DISCHARGE SIDE**

GS.../FH

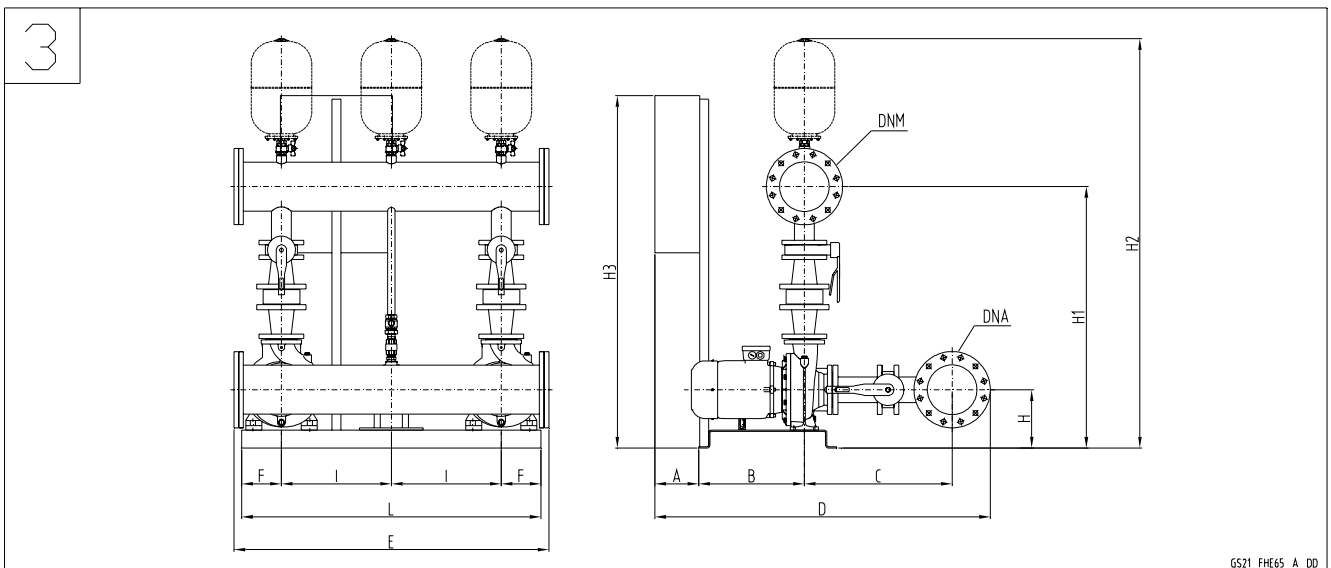
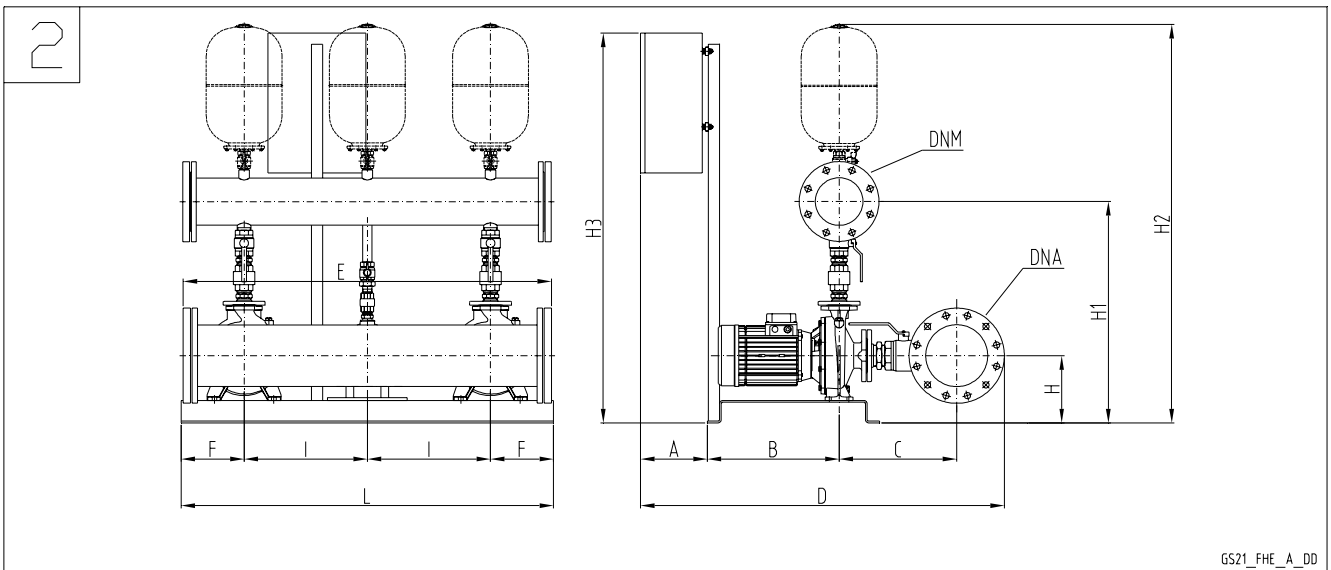
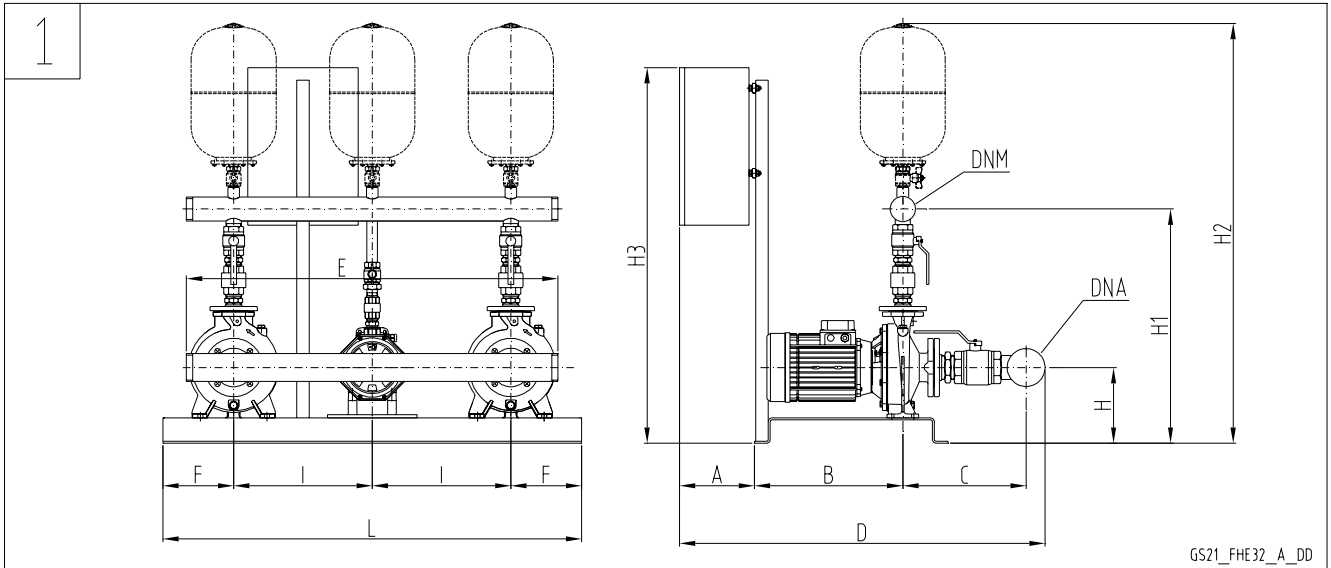

**TWO-PUMP BOOSTER SETS, GSD21 SERIES
HORIZONTAL ELECTRIC PUMPS WITH JOCKEY PUMP
NON-RETURN VALVE ON DISCHARGE SIDE**

GSD21	DRW N°	DNA	DNM	A	B	C	D	E	F	H	H1	H2	H3	I	L
FHE 32-125/07	1	80	65	244	303	305	896	1092	128	192	601	1189	973	370	995
FHE 32-125/11	1	80	65	244	303	305	896	1092	128	192	601	1189	973	370	995
FHE 32-160/15	1	80	65	244	303	305	896	1092	128	212	641	1229	973	370	995
FHE 32-160/22	1	80	65	244	303	305	896	1092	128	212	641	1229	973	370	995
FHE 32-200/30	1	80	65	244	303	305	896	1092	128	240	689	1277	973	370	995
FHE 32-200/40	1	80	65	244	303	305	896	1092	128	240	689	1277	973	370	995
2FHE 32-250/55	1	80	65	244	300	362	950	1092	128	240	704	1292	973	370	995
2FHE 32-250/75	1	80	65	244	300	362	950	1092	128	240	704	1292	973	370	995
FHE 40-125/11	2	100	100	246	471	332	1159	1332	177	192	659	1266	974	490	1334
FHE 40-125/15	2	100	100	244	471	332	1157	1332	177	192	659	1266	974	490	1334
FHE 40-125/22	2	100	100	244	471	332	1157	1332	177	192	659	1266	974	490	1334
FHE 40-160/30	2	100	100	244	471	332	1157	1332	177	212	699	1306	974	490	1334
FHE 40-160/40	2	100	100	244	471	332	1157	1332	177	212	699	1306	974	490	1334
FHE 40-200/55	2	100	100	244	471	352	1177	1332	177	240	747	1354	974	490	1334
FHE 40-200/75	2	100	100	244	471	352	1177	1332	177	240	747	1354	974	490	1334
FHE 40-250/92	2	100	100	244	471	352	1177	1332	177	260	812	1419	1571	490	1334
FHE 40-250/110	2	100	100	244	471	352	1177	1332	177	260	812	1419	1571	490	1334
FHE 40-250/150	2	100	100	244	568	352	1274	1332	177	260	812	1419	1571	490	1334
FHE 50-125/22	2	150	125	246	471	379	1239	1332	177	212	737	1357	974	490	1334
FHE 50-125/30	2	150	125	246	471	379	1239	1332	177	212	737	1357	974	490	1334
FHE 50-125/40	2	150	125	246	471	379	1239	1332	177	212	737	1357	974	490	1334
FHE 50-160/55	2	150	125	246	471	379	1239	1332	177	240	785	1405	974	490	1334
FHE 50-160/75	2	150	125	246	471	379	1239	1332	177	240	785	1405	974	490	1334
FHE 50-200/92	2	150	125	246	471	379	1239	1332	177	240	805	1425	1571	490	1334
FHE 50-200/110	2	150	125	246	471	379	1239	1332	177	240	805	1425	1571	490	1334
FHE 50-250/150	2	150	125	246	568	379	1336	1332	177	260	850	1470	1571	490	1334
FHE 50-250/185	2	150	125	285	815	379	1622	1332	355	300	890	1510	1571	490	1690
FHE 50-250/220	2	150	125	285	815	379	1622	1332	355	300	890	1510	1571	490	1690
FHE65-125/40	3	200	150	246	471	589	1476	1412	177	240	1034	1668	974	490	1334
FHE65-125/55	3	200	150	246	471	589	1476	1412	177	240	1034	1668	974	490	1334
FHE65-125/75	3	200	150	246	471	589	1476	1412	177	240	1034	1668	974	490	1334
FHE65-160/92	3	200	150	246	471	589	1476	1412	177	240	1054	1688	1571	490	1334
FHE65-160/110	3	200	150	246	471	589	1476	1412	177	240	1054	1688	1571	490	1334
FHE65-160/150	3	200	150	246	568	589	1573	1412	177	240	1054	1688	1571	490	1334
FHE65-200/150	3	200	150	246	568	589	1573	1412	177	260	1099	1733	1571	490	1334
FHE65-200/185	3	200	150	285	815	589	1859	1412	355	300	1139	1773	1571	490	1690
FHE65-200/220	3	200	150	285	815	589	1859	1412	355	300	1139	1773	1571	490	1690
FHE65-250/220	3	200	150	285	815	589	1859	1412	355	320	1184	1818	1571	490	1690
FHE80-160/110	3	250	200	246	471	687	1606	1472	177	260	1166	1825	1571	490	1334
FHE80-160/150	3	250	200	246	568	687	1703	1472	177	260	1166	1825	1571	490	1334
FHE80-160/185	3	250	200	285	815	687	1989	1472	355	300	1206	1865	1571	490	1690
FHE80-200/220	3	250	200	285	815	687	1989	1472	355	300	1231	1890	1571	490	1690

Dimensions in mm. Tolerance ± 10 mm.

gs21_fhe-en_b_td

GS.../FH

**TWO-PUMP BOOSTER SETS, GSD21 RA SERIES
HORIZONTAL ELECTRIC PUMPS WITH JOCKEY PUMP
NON-RETURN VALVE ON SUCTION SIDE**

GS.../FH

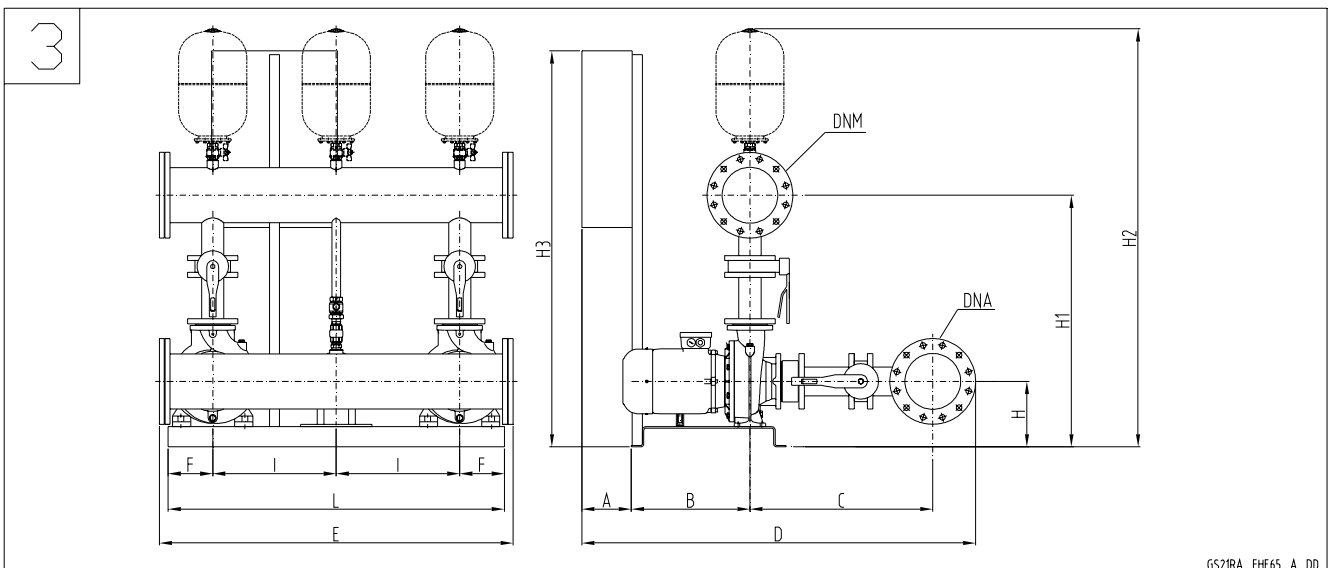
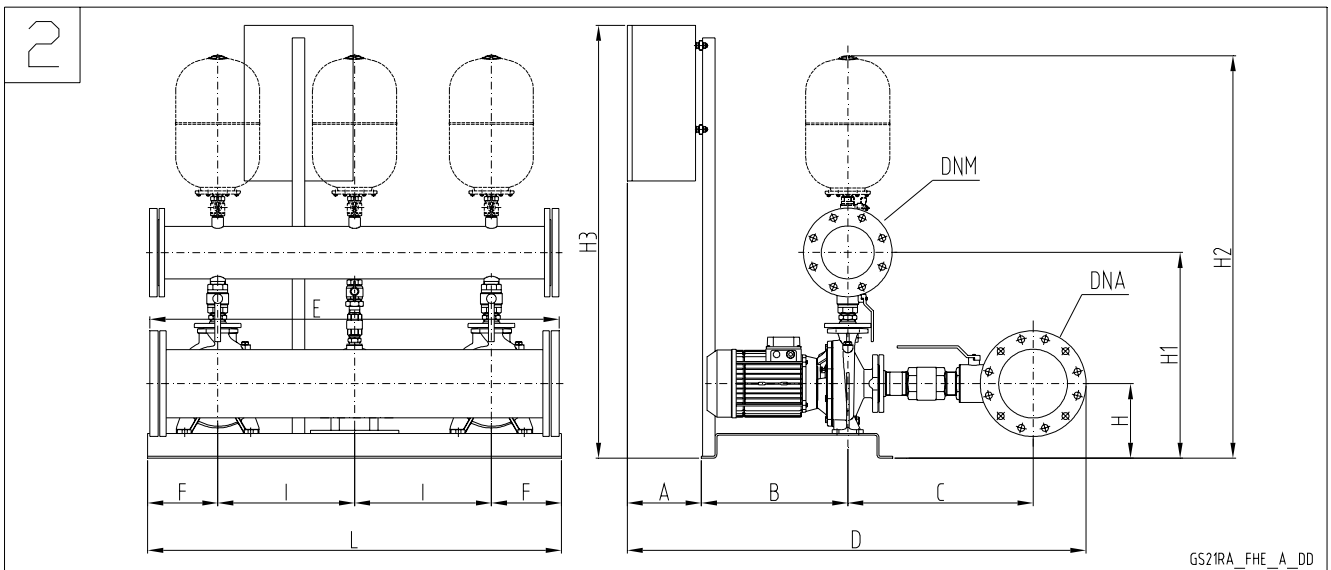
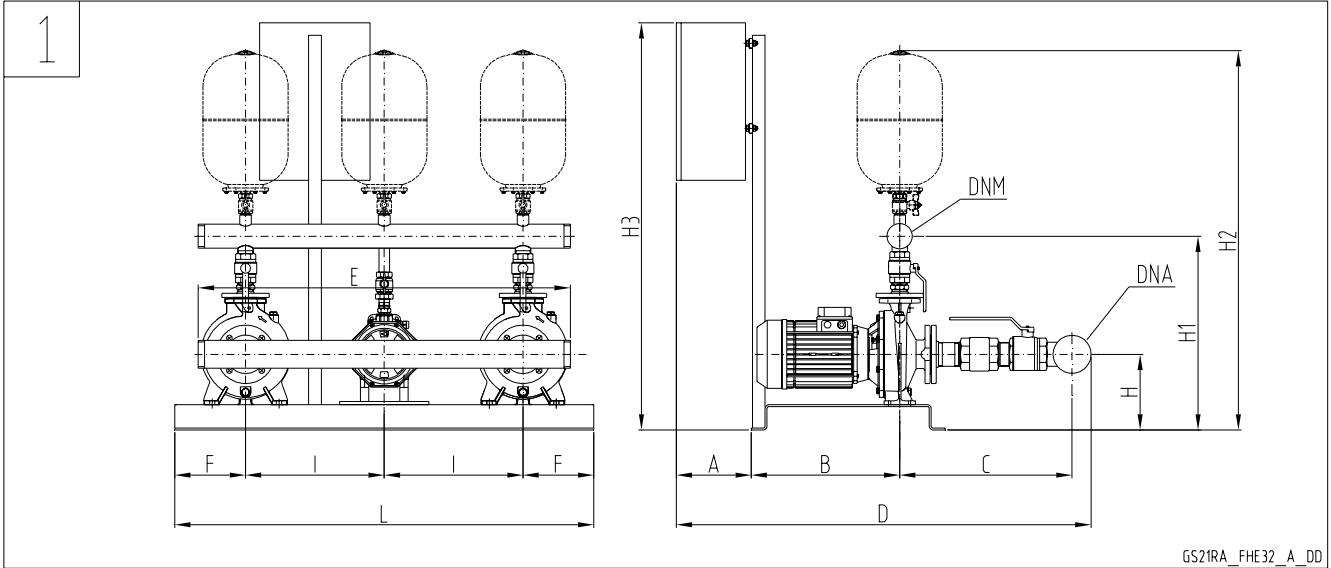

**TWO-PUMP BOOSTER SETS, GSD21 RA SERIES
HORIZONTAL ELECTRIC PUMPS WITH JOCKEY PUMP
NON-RETURN VALVE ON SUCTION SIDE**

GSD21RA	DRW N°	DNA	DNM	A	B	C	D	E	F	H	H1	H2	H3	I	L
FHE 32-125/07	1	80	65	244	303	425	1016	1092	128	192	496	1084	973	370	995
FHE 32-125/11	1	80	65	244	303	425	1016	1092	128	192	496	1084	973	370	995
FHE 32-160/15	1	80	65	244	303	425	1016	1092	128	212	536	1124	973	370	995
FHE 32-160/22	1	80	65	244	303	425	1016	1092	128	212	536	1124	973	370	995
FHE 32-200/30	1	80	65	244	303	425	1016	1092	128	240	584	1172	973	370	995
FHE 32-200/40	1	80	65	244	303	425	1016	1092	128	240	584	1172	973	370	995
2FHE 32-250/55	1	80	65	244	300	441	1029	1092	128	240	583	1171	973	370	995
2FHE 32-250/75	1	80	65	244	300	441	1029	1092	128	240	583	1171	973	370	995
FHE 40-125/11	2	100	100	246	471	514	1341	1332	177	192	548	1155	974	490	1334
FHE 40-125/15	2	100	100	244	471	514	1339	1332	177	192	548	1155	974	490	1334
FHE 40-125/22	2	100	100	244	471	514	1339	1332	177	192	548	1155	974	490	1334
FHE 40-160/30	2	100	100	244	471	514	1339	1332	177	212	588	1195	974	490	1334
FHE 40-160/40	2	100	100	244	471	514	1339	1332	177	212	588	1195	974	490	1334
FHE 40-200/55	2	100	100	244	471	534	1359	1332	177	240	636	1243	974	490	1334
FHE 40-200/75	2	100	100	244	471	534	1359	1332	177	240	636	1243	974	490	1334
FHE 40-250/92	2	100	100	244	471	534	1359	1332	177	260	701	1308	1571	490	1334
FHE 40-250/110	2	100	100	244	471	534	1359	1332	177	260	701	1308	1571	490	1334
FHE 40-250/150	2	100	100	244	568	534	1456	1332	177	260	701	1308	1571	490	1334
FHE 50-125/22	2	150	125	246	471	561	1421	1332	177	212	624	1244	974	490	1334
FHE 50-125/30	2	150	125	246	471	561	1421	1332	177	212	624	1244	974	490	1334
FHE 50-125/40	2	150	125	246	471	561	1421	1332	177	212	624	1244	974	490	1334
FHE 50-160/55	2	150	125	246	471	561	1421	1332	177	240	672	1292	974	490	1334
FHE 50-160/75	2	150	125	246	471	561	1421	1332	177	240	672	1292	974	490	1334
FHE 50-200/92	2	150	125	246	471	561	1421	1332	177	240	692	1312	1571	490	1334
FHE 50-200/110	2	150	125	246	471	561	1421	1332	177	240	692	1312	1571	490	1334
FHE 50-250/150	2	150	125	246	568	561	1518	1332	177	260	737	1357	1571	490	1334
FHE 50-250/185	2	150	125	285	815	561	1804	1332	355	300	777	1397	1571	490	1690
FHE 50-250/220	2	150	125	285	815	561	1804	1332	355	300	777	1397	1571	490	1690
FHE65-125/40	3	200	150	246	471	649	1536	1412	177	240	908	1542	974	490	1334
FHE65-125/55	3	200	150	246	471	649	1536	1412	177	240	908	1542	974	490	1334
FHE65-125/75	3	200	150	246	471	649	1536	1412	177	240	908	1542	974	490	1334
FHE65-160/92	3	200	150	246	471	649	1536	1412	177	240	928	1562	1571	490	1334
FHE65-160/110	3	200	150	246	471	649	1536	1412	177	240	928	1562	1571	490	1334
FHE65-160/150	3	200	150	246	568	649	1633	1412	177	240	928	1562	1571	490	1334
FHE65-200/150	3	200	150	246	568	649	1633	1412	177	260	973	1607	1571	490	1334
FHE65-200/185	3	200	150	285	815	649	1919	1412	355	300	1013	1647	1571	490	1690
FHE65-200/220	3	200	150	285	815	649	1919	1412	355	300	1013	1647	1571	490	1690
FHE65-250/220	3	200	150	285	815	649	1919	1412	355	320	1058	1692	1571	490	1690
FHE80-160/110	3	250	200	246	471	754	1673	1472	177	260	999	1658	1571	490	1334
FHE80-160/150	3	250	200	246	568	754	1770	1472	177	260	999	1658	1571	490	1334
FHE80-160/185	3	250	200	285	815	754	2056	1472	355	300	1039	1698	1571	490	1690
FHE80-200/220	3	250	200	285	815	754	2056	1472	355	300	1064	1723	1571	490	1690

Dimensions in mm. Tolerance ± 10 mm.

gs21ra_fhe-en_b_td

GS.../FH

**TWO-PUMP BOOSTER SETS, GSY21 SERIES
HORIZONTAL ELECTRIC PUMPS WITH JOCKEY PUMP
NON-RETURN VALVE ON DISCHARGE SIDE**

GS.../FH

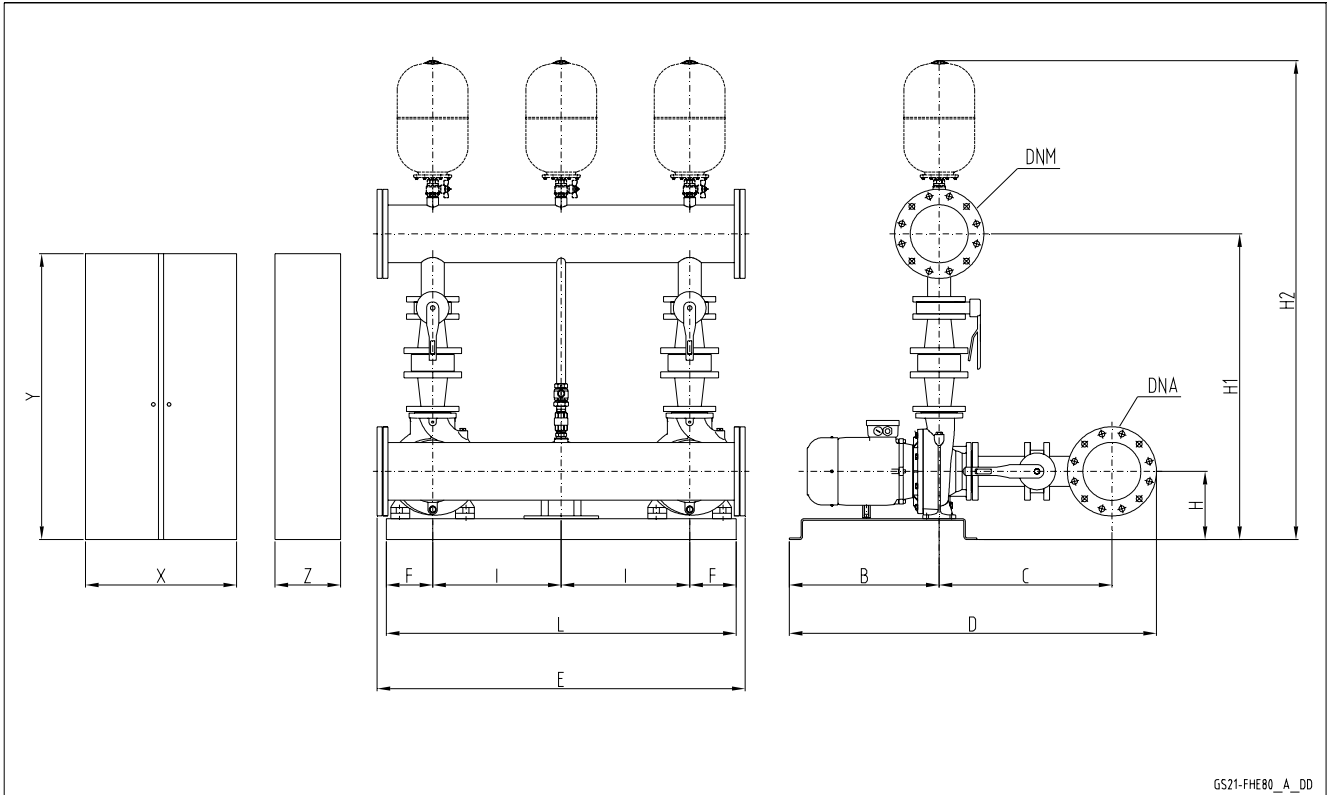

GS21-FHE80_A_DD

GSY21	DNA	DNM	B	C	D	E	F	H	H1	H2	I	L	X	Y	Z
FHS65-250/300	200	150	915	589	1674	1412	355	320	1184	1818	490	1690	600	1500	300
FHS65-250/370	200	150	915	589	1674	1412	355	320	1184	1818	490	1690	600	1500	300
FHS80-200/300	250	200	915	687	1804	1472	355	320	1251	1910	490	1690	600	1500	300
FHS80-250/370	250	200	915	687	1804	1472	355	320	1281	1940	490	1690	600	1500	300
FHS80-250/450	DIMENSIONS ON REQUEST														
FHS80-250/550	DIMENSIONS ON REQUEST														

Dimensions in mm. Tolerance ± 10 mm.

gs21_fhe80-en_b_td

**TWO-PUMP BOOSTER SETS, GSY21 RA SERIES
HORIZONTAL ELECTRIC PUMPS WITH JOCKEY PUMP
NON-RETURN VALVE ON SUCTION SIDE**

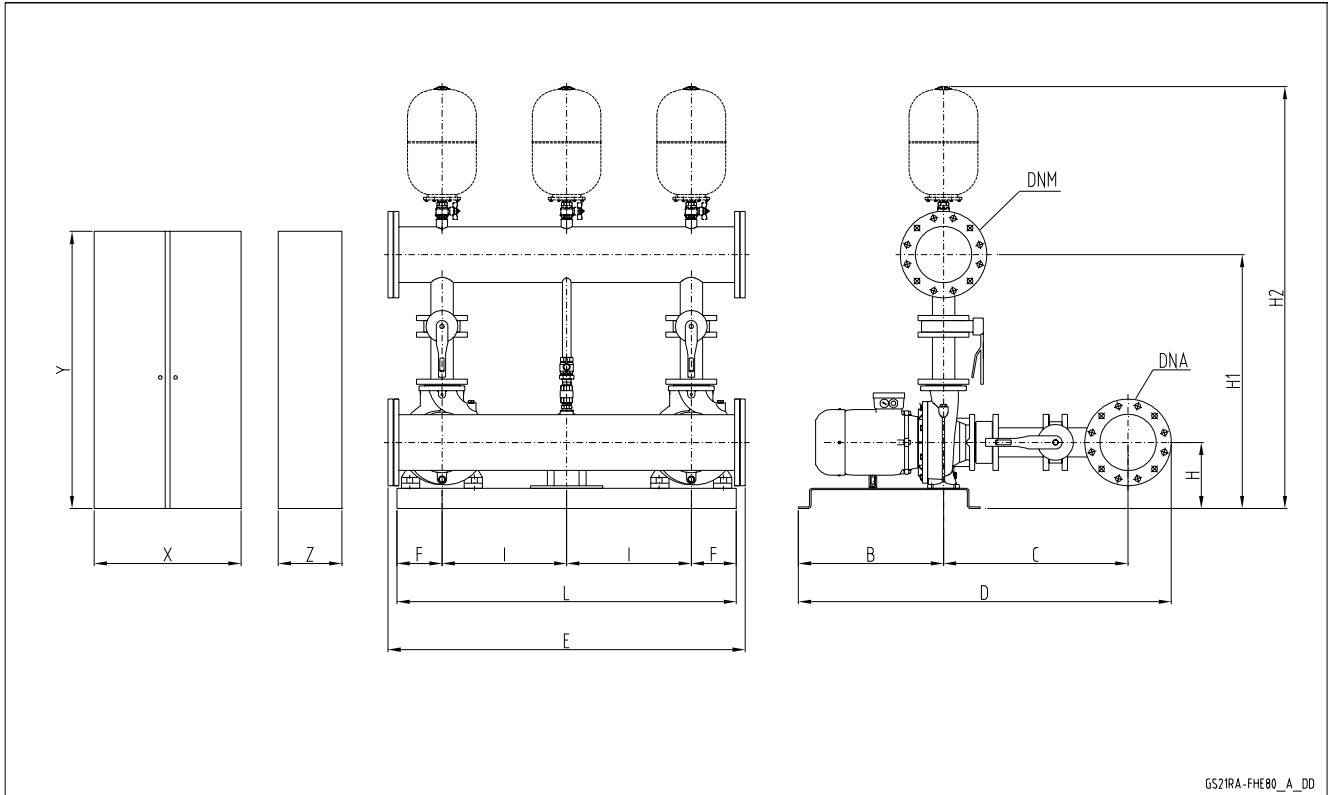

GS.../FH

GSY21RA	DNA	DNM	B	C	D	E	F	H	H1	H2	I	L	X	Y	Z
FHS65-250/300	200	150	915	649	1734	1412	355	320	1058	1692	490	1690	600	1500	300
FHS65-250/370	200	150	915	649	1734	1412	355	320	1058	1692	490	1690	600	1500	300
FHS80-200/300	250	200	915	754	1871	1472	355	320	1084	1743	490	1690	600	1500	300
FHS80-250/370	250	200	915	754	1871	1472	355	320	1114	1773	490	1690	600	1500	300
FHS80-250/450	DIMENSIONS ON REQUEST														
FHS80-250/550	DIMENSIONS ON REQUEST														

Dimensions in mm. Tolerance ± 10 mm.

gs21ra_fhe80-en_b_td

Booster sets

MARKET SECTORS CIVIL, INDUSTRIAL

APPLICATIONS

- Water network supply in condominiums, offices, hotels, shopping centres, factories.
- Water supply to agricultural water networks (e.g. irrigation).

GSD30 - GSY30 Series

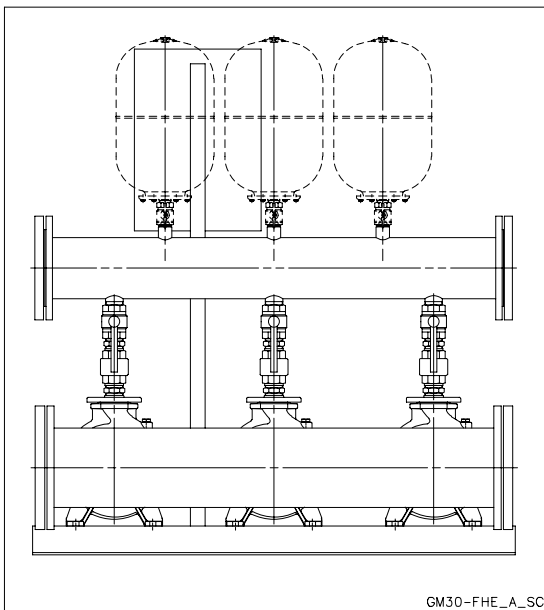

SPECIFICATIONS

- **Flow rate** up to 630 m³/h.
- **Head** up to 100 m.
- Electrical panel supply voltage:
3 x 400V ± 10%.
- Frequency 50 Hz.
- Voltage for controls outside panel:
24 Vac.
- Electrical panel protection class IP 55.
- Maximum service pump power:
3 x 55 kW.
- **Motor start-up:**
 - Direct for powers up to 22 kW inclusive for pump (GSD/).
 - Star/Delta for higher powers (GSY/ set).
 - Softstarter, available on request (GSR../ set).
- **Electric pumps with horizontal axis:**
 - FH series (motor protection class IP55).
- Maximum operating pressure:
16 bar.
- Maximum temperature of pumped liquid : +80°C.

**THREE-PUMP BOOSTER SETS, GSD30 SERIES
HORIZONTAL ELECTRIC PUMPS WITH NON-RETURN VALVE
ON DISCHARGE SIDE**

GS.../FH

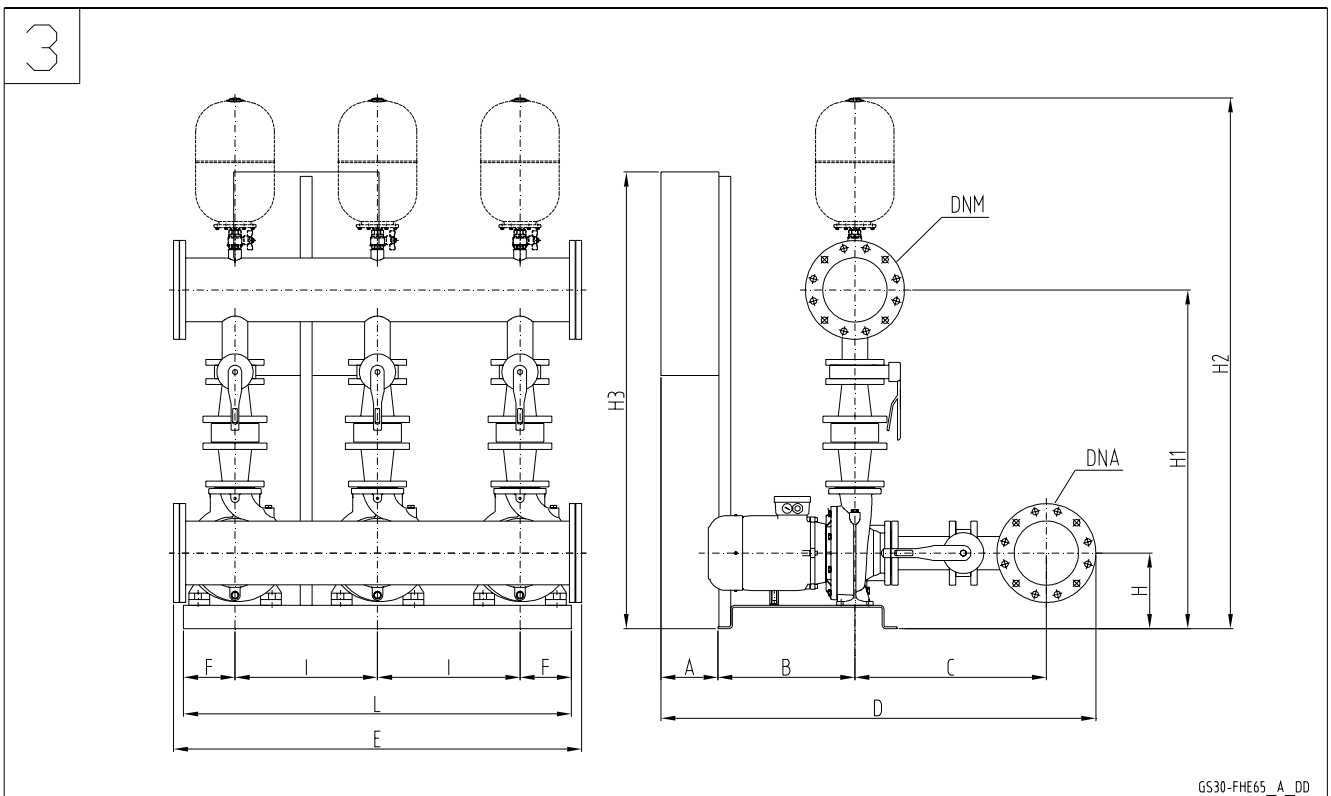
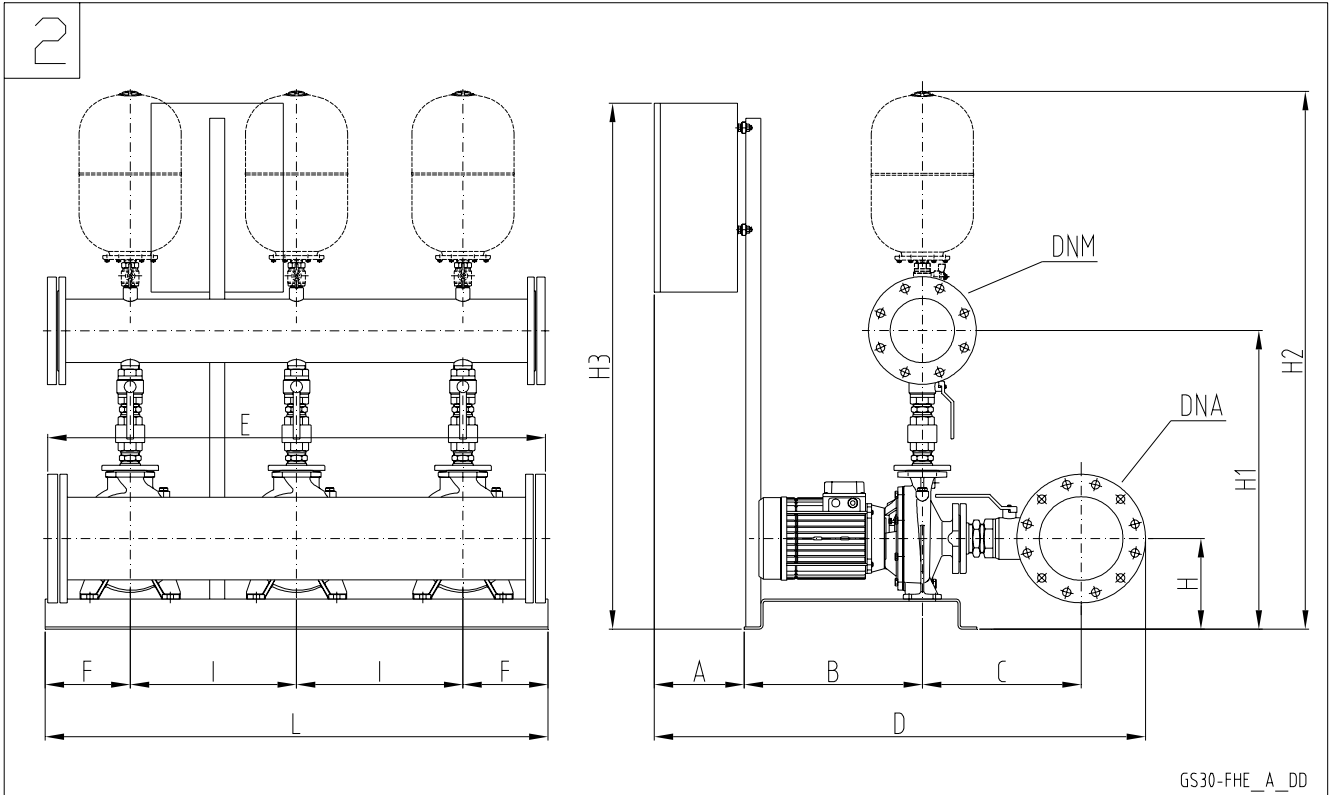

**THREE-PUMP BOOSTER SETS, GSD30 SERIES
HORIZONTAL ELECTRIC PUMPS WITH NON-RETURN VALVE
ON DISCHARGE SIDE**

GSD30	DRW N°	DNA	DNM	A	B	C	D	E	F	H	H1	H2	H3	I	L
FHE 32-125/07	2	100	80	244	303	317	974	1092	128	192	608	1202	973	370	995
FHE 32-125/11	2	100	80	244	303	317	974	1092	128	192	608	1202	973	370	995
FHE 32-160/15	2	100	80	244	303	317	974	1092	128	212	648	1242	973	370	995
FHE 32-160/22	2	100	80	244	303	317	974	1092	128	212	648	1242	973	370	995
FHE 32-200/30	2	100	80	244	303	317	974	1092	128	240	696	1290	973	370	995
FHE 32-200/40	2	100	80	244	303	317	974	1092	128	240	696	1290	973	370	995
2FHE 32-250/55	2	100	80	244	300	374	1028	1092	128	240	711	1305	973	370	995
2FHE 32-250/75	2	100	80	244	300	374	1028	1092	128	240	711	1305	973	370	995
FHE 40-125/11	2	125	125	246	471	345	1187	1332	177	192	672	1292	974	490	1334
FHE 40-125/15	2	125	125	244	471	345	1185	1332	177	192	672	1292	974	490	1334
FHE 40-125/22	2	125	125	244	471	345	1185	1332	177	192	672	1292	974	490	1334
FHE 40-160/30	2	125	125	244	471	345	1185	1332	177	212	712	1332	974	490	1334
FHE 40-160/40	2	125	125	244	471	345	1185	1332	177	212	712	1332	974	490	1334
FHE 40-200/55	2	125	125	244	471	365	1205	1332	177	240	760	1380	974	490	1334
FHE 40-200/75	2	125	125	244	471	365	1205	1332	177	240	760	1380	974	490	1334
FHE 40-250/92	2	125	125	244	471	365	1205	1332	177	260	825	1445	1571	490	1334
FHE 40-250/110	2	125	125	244	471	365	1205	1332	177	260	825	1445	1571	490	1334
FHE 40-250/150	2	125	125	244	568	365	1302	1332	177	260	825	1445	1571	490	1334
FHE 50-125/22	2	200	150	246	471	405	1292	1332	177	212	751	1385	974	490	1334
FHE 50-125/30	2	200	150	246	471	405	1292	1332	177	212	751	1385	974	490	1334
FHE 50-125/40	2	200	150	246	471	405	1292	1332	177	212	751	1385	974	490	1334
FHE 50-160/55	2	200	150	246	471	405	1292	1332	177	240	799	1433	974	490	1334
FHE 50-160/75	2	200	150	246	471	405	1292	1332	177	240	799	1433	974	490	1334
FHE 50-200/92	2	200	150	246	471	405	1292	1332	177	240	819	1453	1571	490	1334
FHE 50-200/110	2	200	150	246	471	405	1292	1332	177	240	819	1453	1571	490	1334
FHE 50-250/150	2	200	150	246	568	405	1389	1332	177	260	864	1498	1571	490	1334
FHE 50-250/185	2	200	150	285	815	405	1675	1332	355	300	904	1538	1571	490	1690
FHE 50-250/220	2	200	150	285	815	405	1675	1332	355	300	904	1538	1571	490	1690
FHE65-125/40	3	250	200	246	471	616	1535	1472	177	240	1060	1719	974	490	1334
FHE65-125/55	3	250	200	246	471	616	1535	1472	177	240	1060	1719	974	490	1334
FHE65-125/75	3	250	200	246	471	616	1535	1472	177	240	1060	1719	974	490	1334
FHE65-160/92	3	250	200	246	471	616	1535	1472	177	240	1080	1739	1571	490	1334
FHE65-160/110	3	250	200	246	471	616	1535	1472	177	240	1080	1739	1571	490	1334
FHE65-160/150	3	250	200	246	568	616	1632	1472	177	240	1080	1739	1571	490	1334
FHE65-200/150	3	250	200	246	568	616	1632	1472	177	260	1125	1784	1571	490	1334
FHE65-200/185	3	250	200	285	815	616	1918	1472	355	300	1165	1824	1571	490	1690
FHE65-200/220	3	250	200	285	815	616	1918	1472	355	300	1165	1824	1571	490	1690
FHE65-250/220	3	250	200	285	815	616	1918	1472	355	320	1210	1869	1571	490	1690
FHE80-160/110	3	300	250	246	471	712	1659	1472	177	260	1193	1879	1571	490	1334
FHE80-160/150	3	300	250	246	568	712	1756	1472	177	260	1193	1879	1571	490	1334
FHE80-160/185	3	300	250	285	815	712	2042	1472	355	300	1233	1919	1571	490	1690
FHE80-200/220	3	300	250	285	815	712	2042	1472	355	300	1258	1944	1571	490	1690

Dimensions in mm. Tolerance ± 10 mm.

gs30_fhe-en_b_td

GS.../FH

**THREE-PUMP BOOSTER SETS, GSD30 RA SERIES
HORIZONTAL ELECTRIC PUMPS WITH NON-RETURN VALVE
ON SUCTION SIDE**

GS.../FH

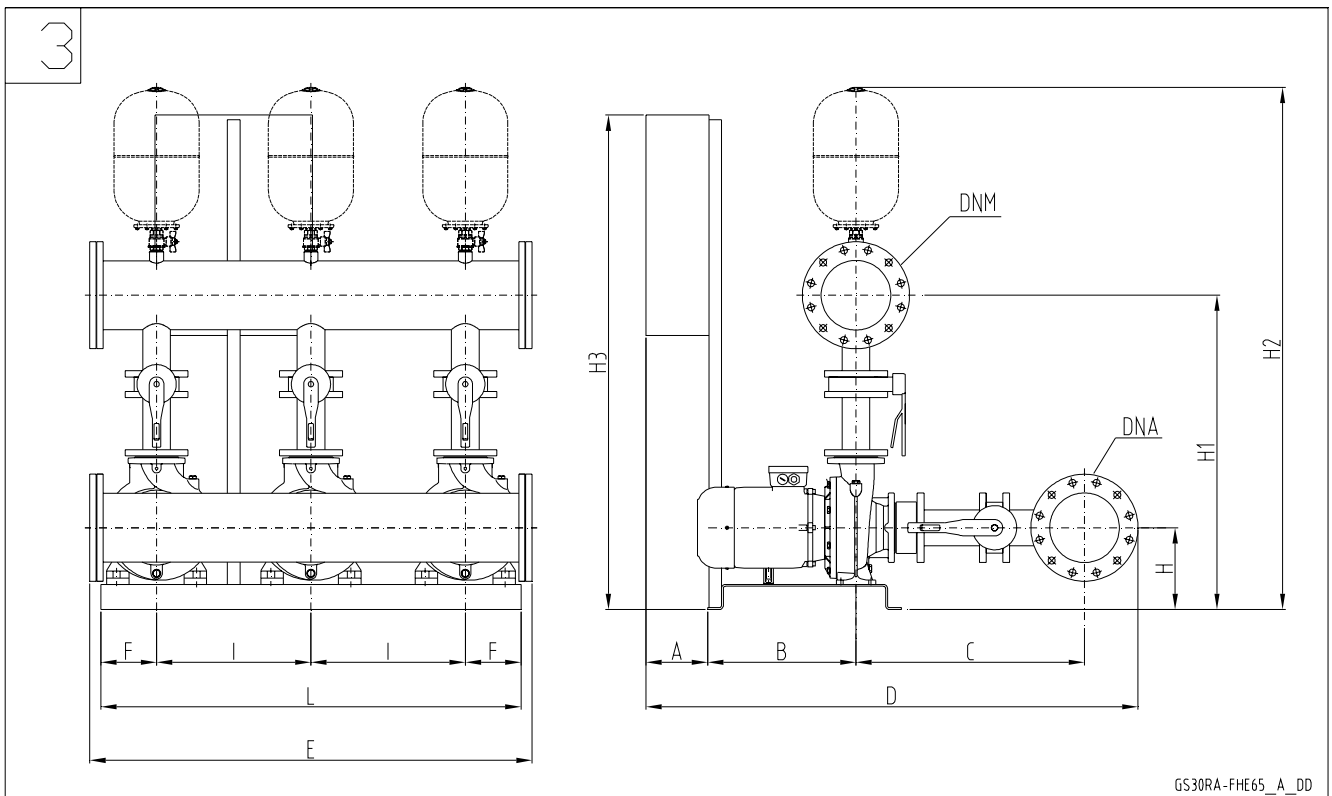
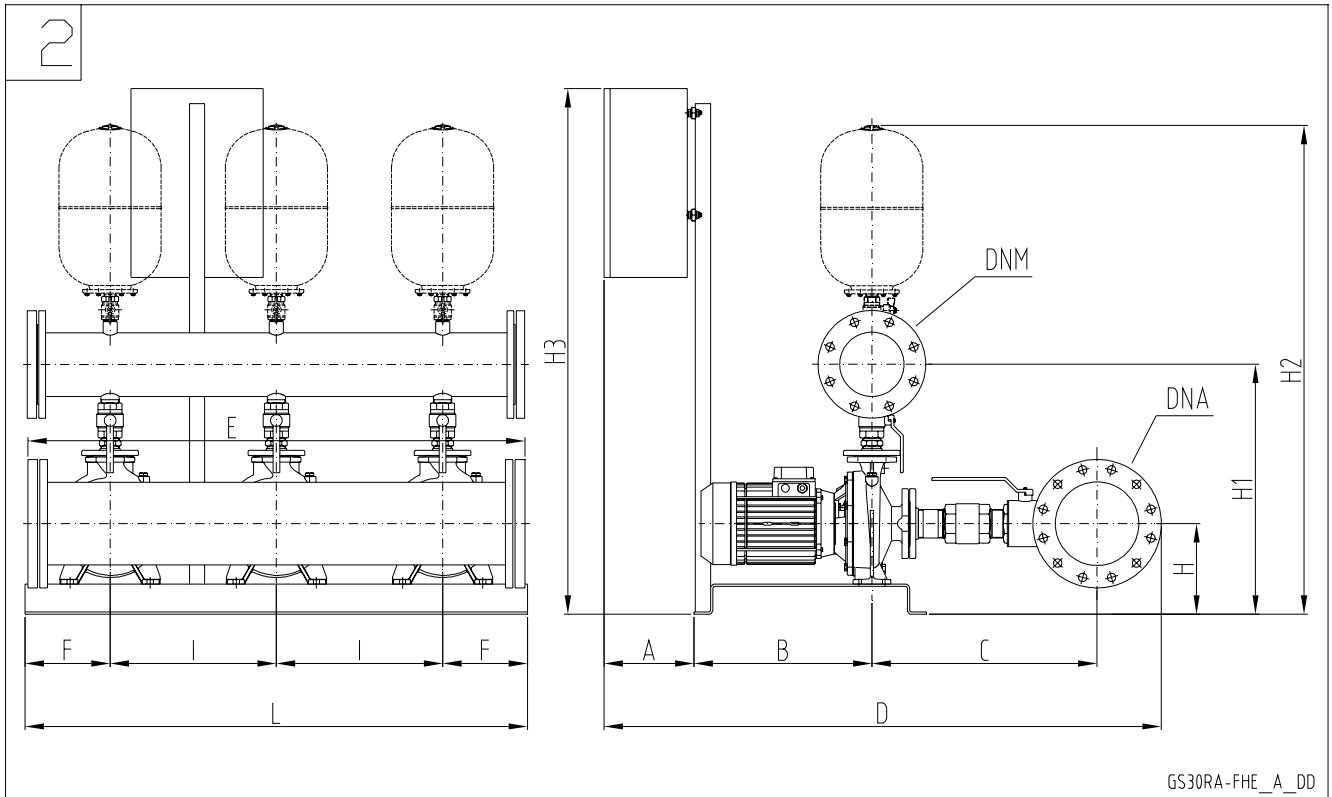

**THREE-PUMP BOOSTER SETS, GSD30 RA SERIES
HORIZONTAL ELECTRIC PUMPS WITH NON-RETURN VALVE
ON SUCTION SIDE**

GSD30RA	DRW N°	DNA	DNM	A	B	C	D	E	F	H	H1	H2	H3	I	L
FHE 32-125/07	2	100	80	244	303	437	1094	1092	128	192	503	1097	973	370	995
FHE 32-125/11	2	100	80	244	303	437	1094	1092	128	192	503	1097	973	370	995
FHE 32-160/15	2	100	80	244	303	437	1094	1092	128	212	543	1137	973	370	995
FHE 32-160/22	2	100	80	244	303	437	1094	1092	128	212	543	1137	973	370	995
FHE 32-200/30	2	100	80	244	303	437	1094	1092	128	240	591	1185	973	370	995
FHE 32-200/40	2	100	80	244	303	437	1094	1092	128	240	591	1185	973	370	995
2FHE 32-250/55	2	100	80	244	300	453	1107	1092	128	240	590	1184	973	370	995
2FHE 32-250/75	2	100	80	244	300	453	1107	1092	128	240	590	1184	973	370	995
FHE 40-125/11	2	125	125	246	471	527	1369	1332	177	192	561	1181	974	490	1334
FHE 40-125/15	2	125	125	244	471	527	1367	1332	177	192	561	1181	974	490	1334
FHE 40-125/22	2	125	125	244	471	527	1367	1332	177	192	561	1181	974	490	1334
FHE 40-160/30	2	125	125	244	471	527	1367	1332	177	212	601	1221	974	490	1334
FHE 40-160/40	2	125	125	244	471	527	1367	1332	177	212	601	1221	974	490	1334
FHE 40-200/55	2	125	125	244	471	547	1387	1332	177	240	649	1269	974	490	1334
FHE 40-200/75	2	125	125	244	471	547	1387	1332	177	240	649	1269	974	490	1334
FHE 40-250/92	2	125	125	244	471	547	1387	1332	177	260	714	1334	1571	490	1334
FHE 40-250/110	2	125	125	244	471	547	1387	1332	177	260	714	1334	1571	490	1334
FHE 40-250/150	2	125	125	244	568	547	1484	1332	177	260	714	1334	1571	490	1334
FHE 50-125/22	2	200	150	246	471	587	1474	1332	177	212	638	1272	974	490	1334
FHE 50-125/30	2	200	150	246	471	587	1474	1332	177	212	638	1272	974	490	1334
FHE 50-125/40	2	200	150	246	471	587	1474	1332	177	212	638	1272	974	490	1334
FHE 50-160/55	2	200	150	246	471	587	1474	1332	177	240	686	1320	974	490	1334
FHE 50-160/75	2	200	150	246	471	587	1474	1332	177	240	686	1320	974	490	1334
FHE 50-200/92	2	200	150	246	471	587	1474	1332	177	240	706	1340	1571	490	1334
FHE 50-200/110	2	200	150	246	471	587	1474	1332	177	240	706	1340	1571	490	1334
FHE 50-250/150	2	200	150	246	568	587	1571	1332	177	260	751	1385	1571	490	1334
FHE 50-250/185	2	200	150	285	815	587	1857	1332	355	300	791	1425	1571	490	1690
FHE 50-250/220	2	200	150	285	815	587	1857	1332	355	300	791	1425	1571	490	1690
FHE65-125/40	3	250	200	246	471	670	1589	1472	177	240	934	1593	974	490	1334
FHE65-125/55	3	250	200	246	471	670	1589	1472	177	240	934	1593	974	490	1334
FHE65-125/75	3	250	200	246	471	670	1589	1472	177	240	934	1593	974	490	1334
FHE65-160/92	3	250	200	246	471	670	1589	1472	177	240	954	1613	1571	490	1334
FHE65-160/110	3	250	200	246	471	670	1589	1472	177	240	954	1613	1571	490	1334
FHE65-160/150	3	250	200	246	568	670	1686	1472	177	240	954	1613	1571	490	1334
FHE65-200/150	3	250	200	246	568	670	1686	1472	177	260	999	1658	1571	490	1334
FHE65-200/185	3	250	200	285	815	670	1972	1472	355	300	1039	1698	1571	490	1690
FHE65-200/220	3	250	200	285	815	670	1972	1472	355	300	1039	1698	1571	490	1690
FHE65-250/220	3	250	200	285	815	670	1972	1472	355	320	1084	1743	1571	490	1690
FHE80-160/110	3	300	250	246	471	773	1720	1472	177	260	1026	1712	1571	490	1334
FHE80-160/150	3	300	250	246	568	773	1817	1472	177	260	1026	1712	1571	490	1334
FHE80-160/185	3	300	250	285	815	773	2103	1472	355	300	1066	1752	1571	490	1690
FHE80-200/220	3	300	250	285	815	773	2103	1472	355	300	1091	1777	1571	490	1690

Dimensions in mm. Tolerance ± 10 mm.

gs30ra_fhe-en_b_td

THREE-PUMP BOOSTER SETS, GSY30 SERIES HORIZONTAL ELECTRIC PUMPS WITH NON-RETURN VALVE ON DISCHARGE SIDE

GS.../FH

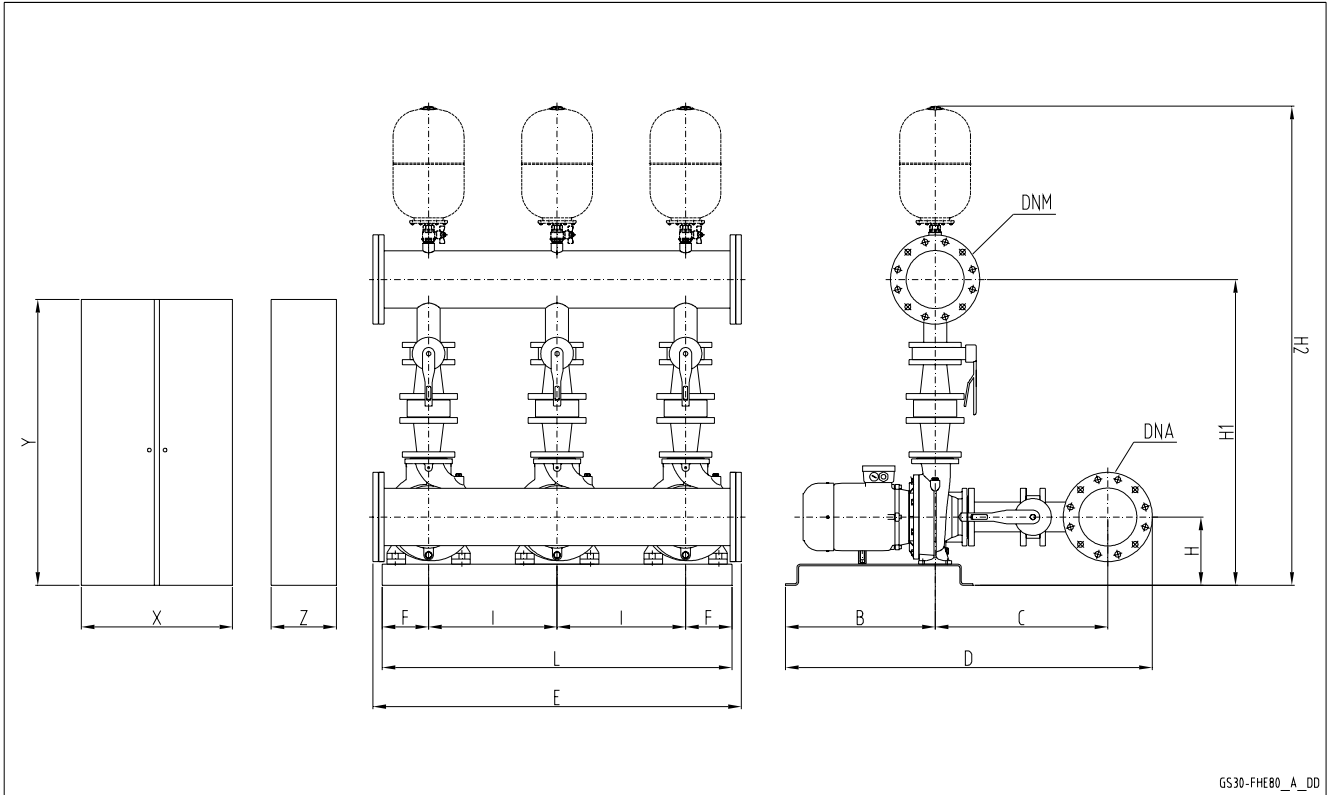

GS30-FHE80_A_DD

GSY30	DNA	DNM	B	C	D	E	F	H	H1	H2	I	L	X	Y	Z
FHS65-250/300	250	200	915	616	1733	1472	355	320	1210	1869	490	1690	600	1500	300
FHS65-250/370	250	200	915	616	1733	1472	355	320	1210	1869	490	1690	600	1500	300
FHS80-200/300	300	250	915	712	1857	1472	355	320	1278	1964	490	1690	600	1500	300
FHS80-250/370	300	250	915	712	1857	1472	355	320	1308	1994	490	1690	600	1500	300
FHS80-250/450	DIMENSIONS ON REQUEST														
FHS80-250/550	DIMENSIONS ON REQUEST														

Dimensions in mm. Tolerance ± 10 mm.

gs30_fhe80-en_b_td

THREE-PUMP BOOSTER SETS, GSY30 RA SERIES HORIZONTAL ELECTRIC PUMPS WITH NON-RETURN VALVE ON SUCTION SIDE

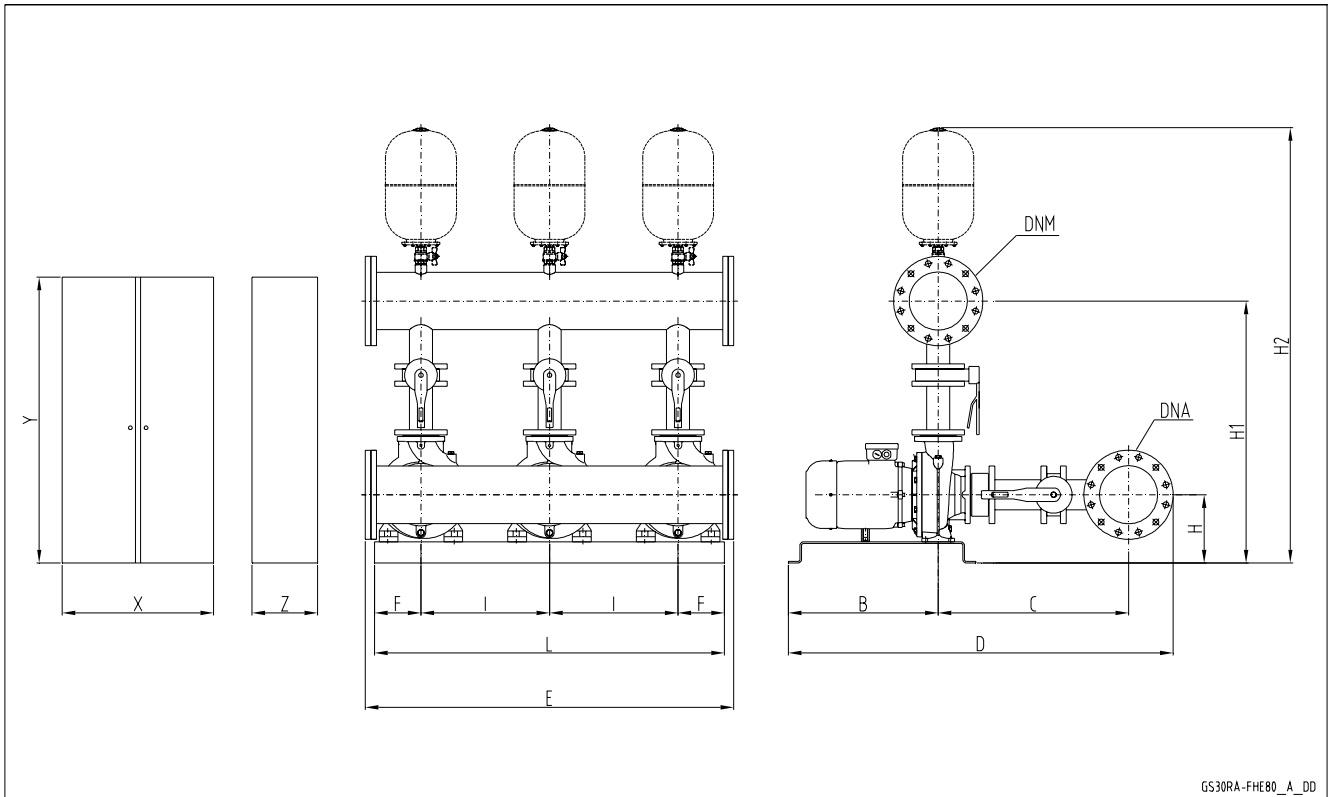

GSY30RA-FHE80_A_DD

GS.../FH

GSY30RA	DNA	DNM	B	C	D	E	F	H	H1	H2	I	L	X	Y	Z
FHS65-250/300	250	200	915	670	1787	1472	355	320	1084	1743	490	1690	600	1500	300
FHS65-250/370	250	200	915	670	1787	1472	355	320	1084	1743	490	1690	600	1500	300
FHS80-200/300	300	250	915	773	1918	1472	355	320	1111	1797	490	1690	600	1500	300
FHS80-250/370	300	250	915	773	1918	1472	355	320	1141	1827	490	1690	600	1500	300
FHS80-250/450	DIMENSIONS ON REQUEST														
FHS80-250/550	DIMENSIONS ON REQUEST														

Dimensions in mm. Tolerance ± 10 mm.

gs30ra_fhe80-en_b_td

**BOOSTER SETS, GS.../FH SERIES
OPERATING CHARACTERISTICS AT 50 Hz (JOCKEY PUMP)**

GS.../FH

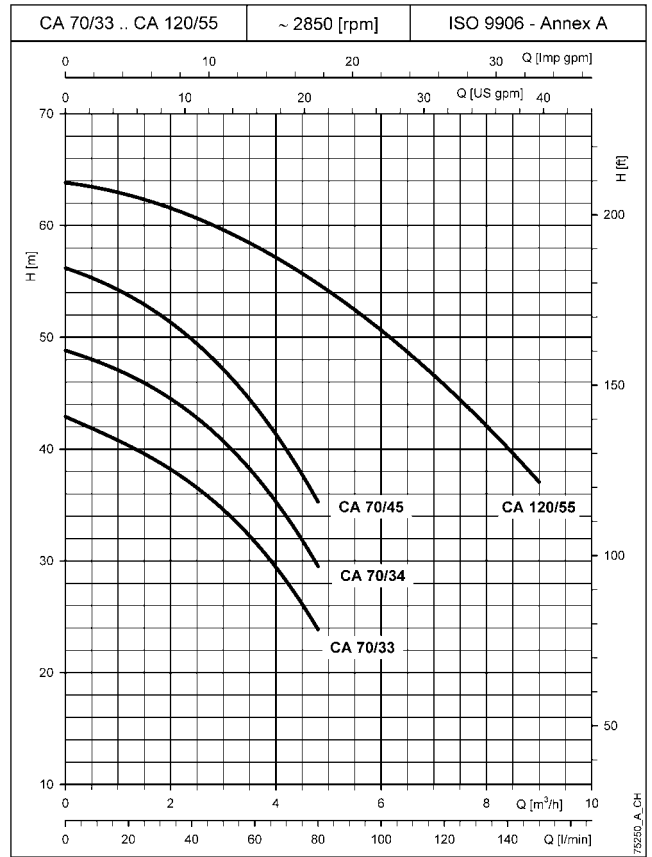
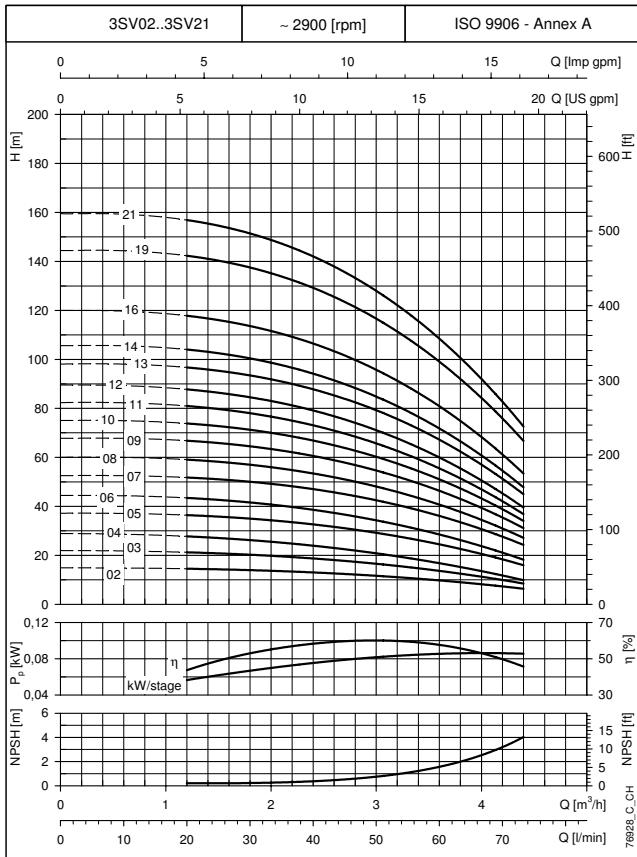

The performance curves do not take into account flow resistance in the valves and piping.
The curves show performance with one pump running.
These performances are valid for liquids with density $\rho = 1.0 \text{ kg/dm}^3$ and kinematic viscosity $\nu = 1 \text{ mm}^2/\text{s}$.

**BOOSTER SETS, GS.../FH SERIES
OPERATING CHARACTERISTICS AT 50 Hz (SERVICE PUMP)**

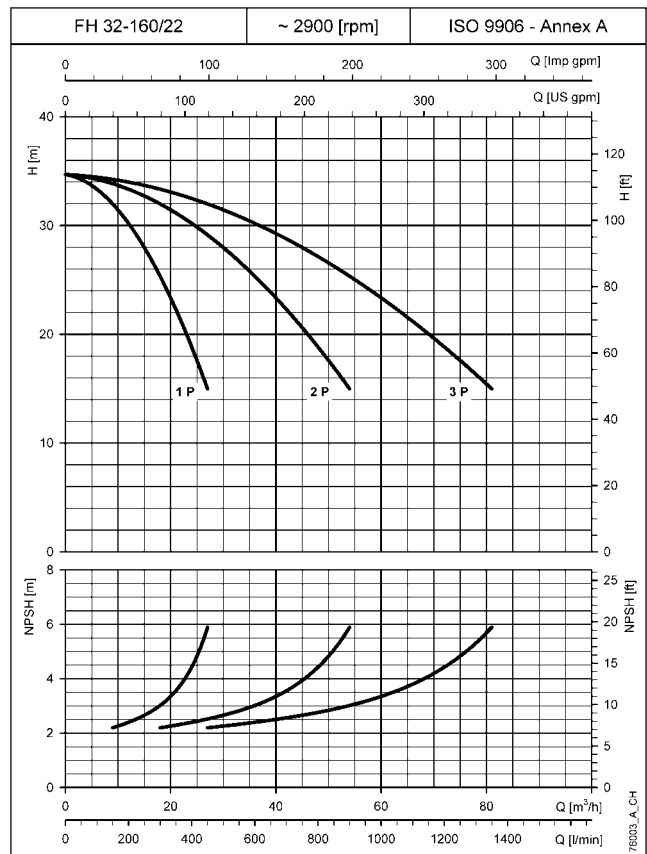
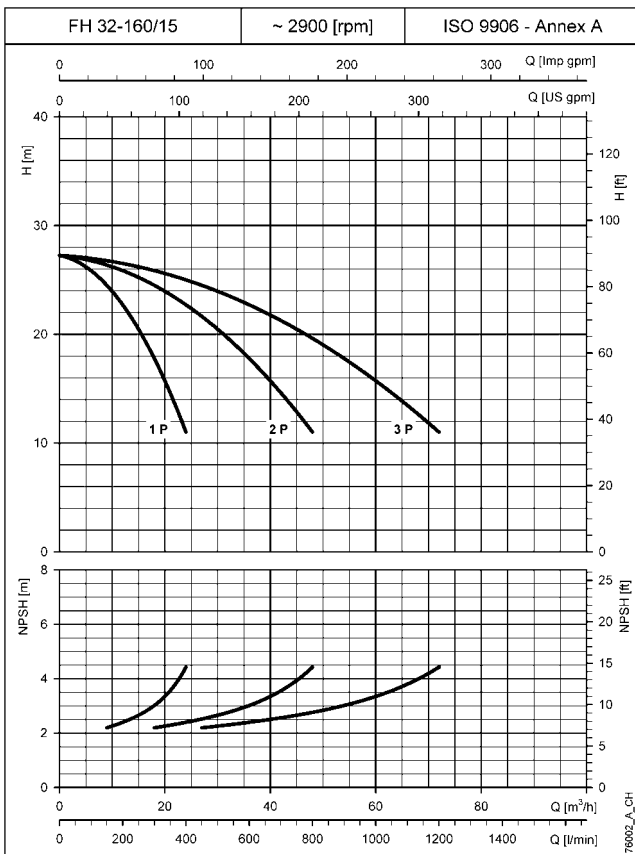
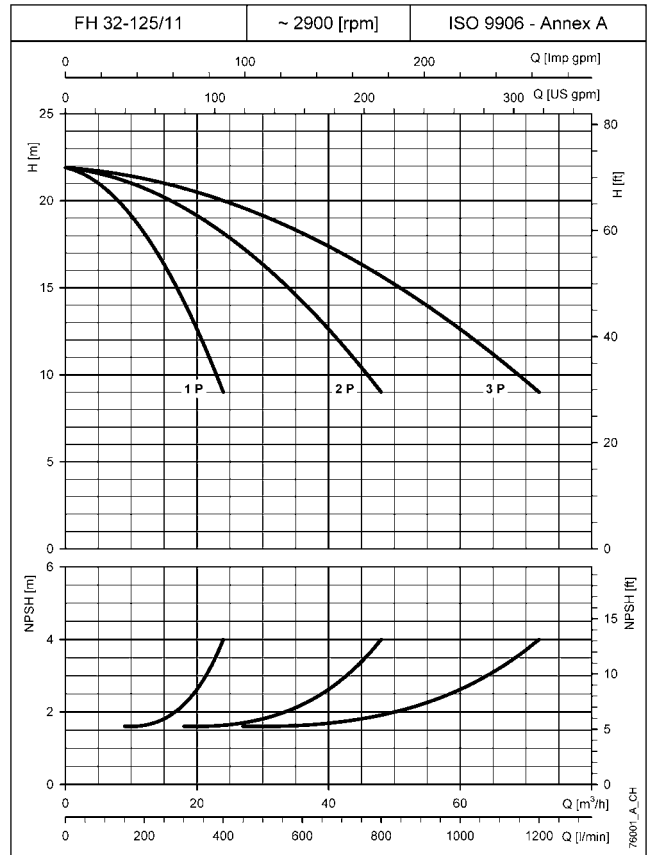
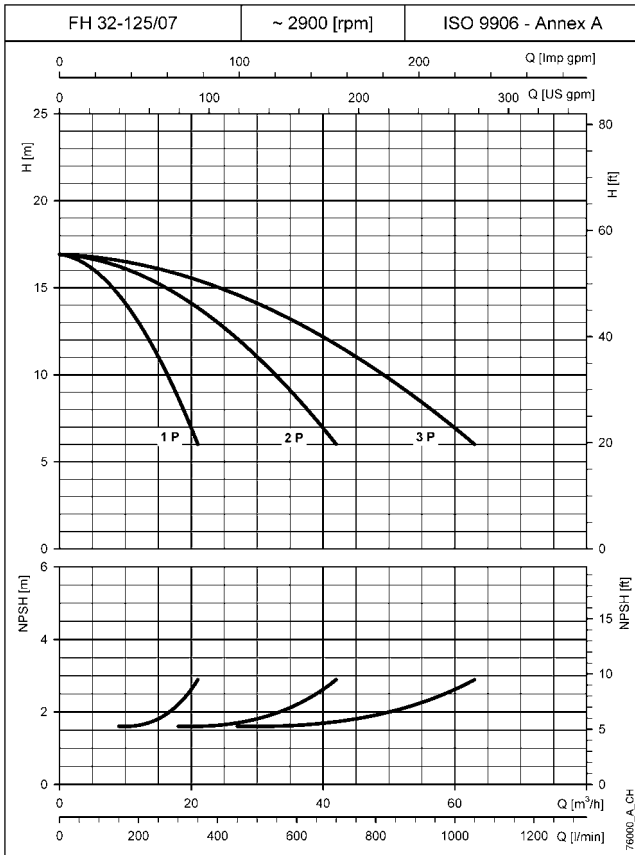

GS.../FH

The performance curves do not take into account flow resistance in the valves and piping.
The curves show the performance with one, two and three pumps running.
These performances are valid for liquids with density $\rho = 1.0 \text{ Kg/dm}^3$ and kinematic viscosity $\nu = 1 \text{ mm}^2/\text{s}$.
The declared NPSH values are laboratory values: for practical use we recommend increasing these values by 0.5 m.

**BOOSTER SETS, GS.../FH SERIES
OPERATING CHARACTERISTICS AT 50 Hz (SERVICE PUMP)**

GS.../FH

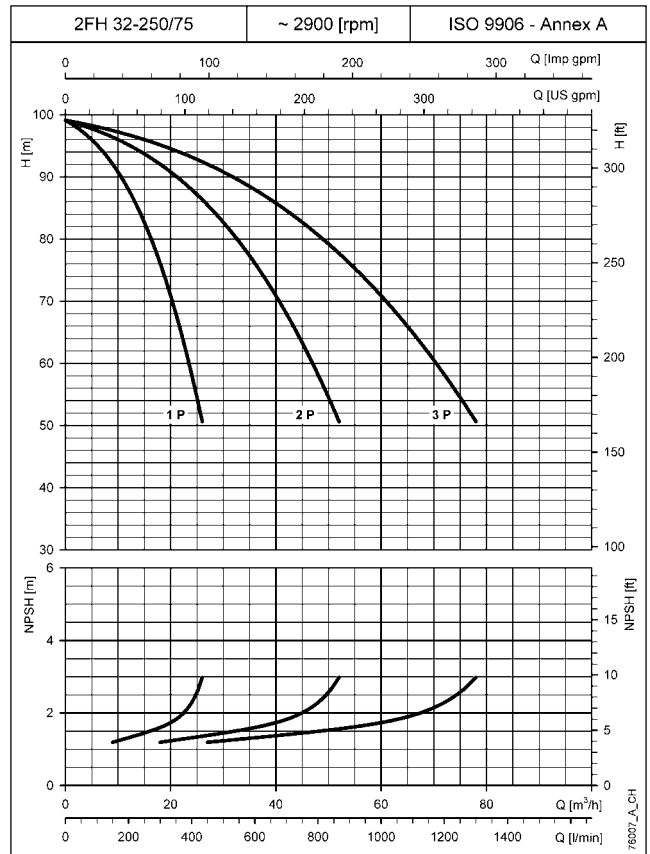
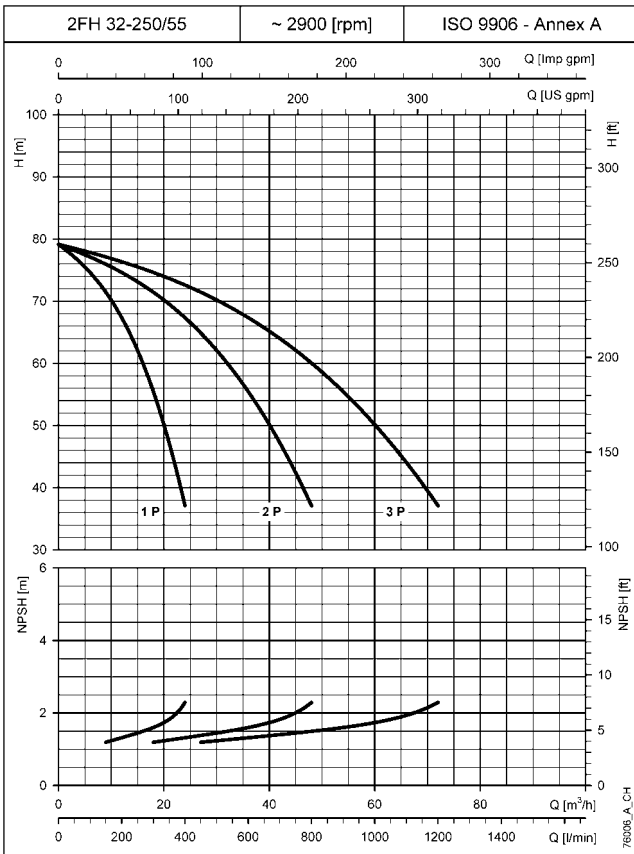
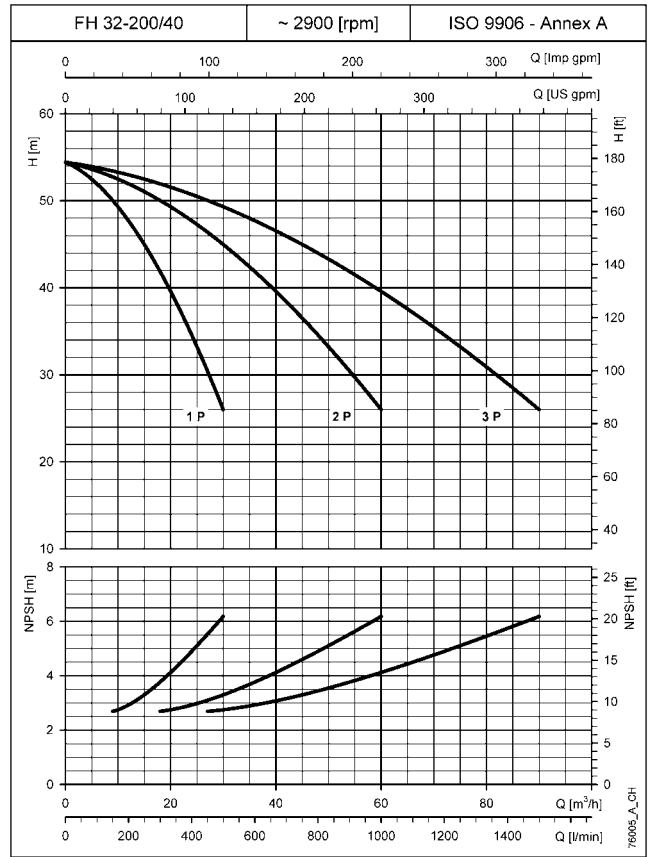
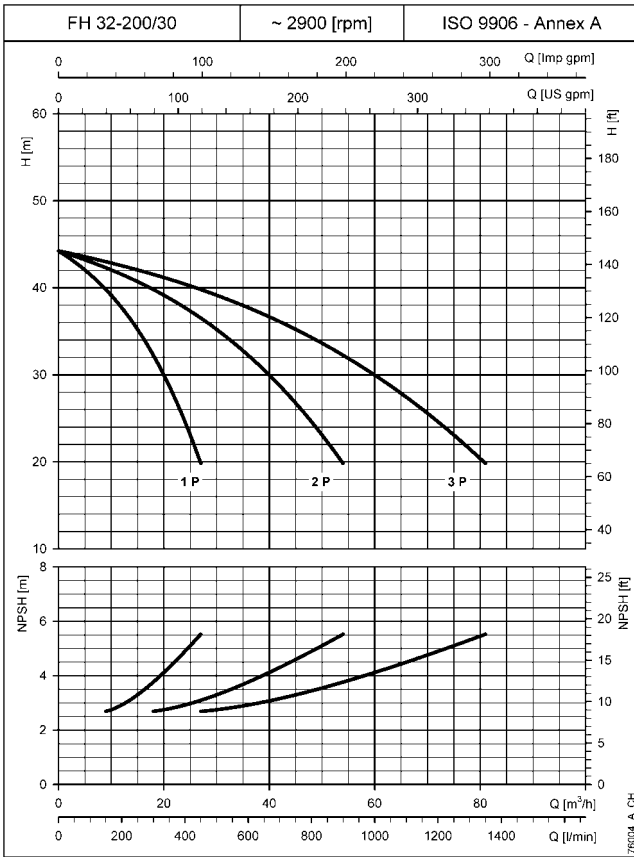

The performance curves do not take into account flow resistance in the valves and piping.
 The curves show the performance with one, two and three pumps running.
 These performances are valid for liquids with density $\rho = 1.0 \text{ Kg/dm}^3$ and kinematic viscosity $\nu = 1 \text{ mm}^2/\text{s}$.
 The declared NPSH values are laboratory values: for practical use we recommend increasing these values by 0.5 m.

**BOOSTER SETS, GS.../FH SERIES
OPERATING CHARACTERISTICS AT 50 Hz (SERVICE PUMP)**

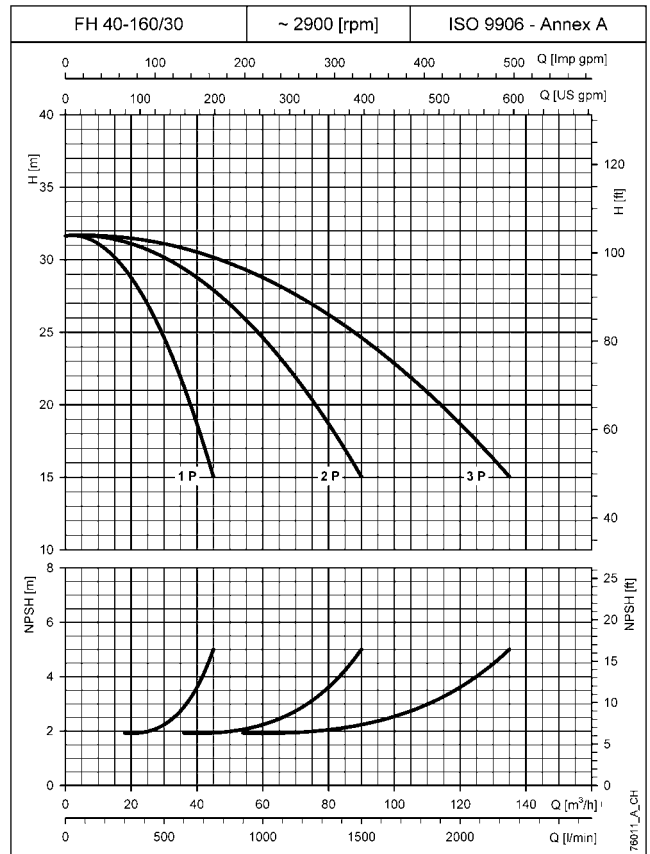
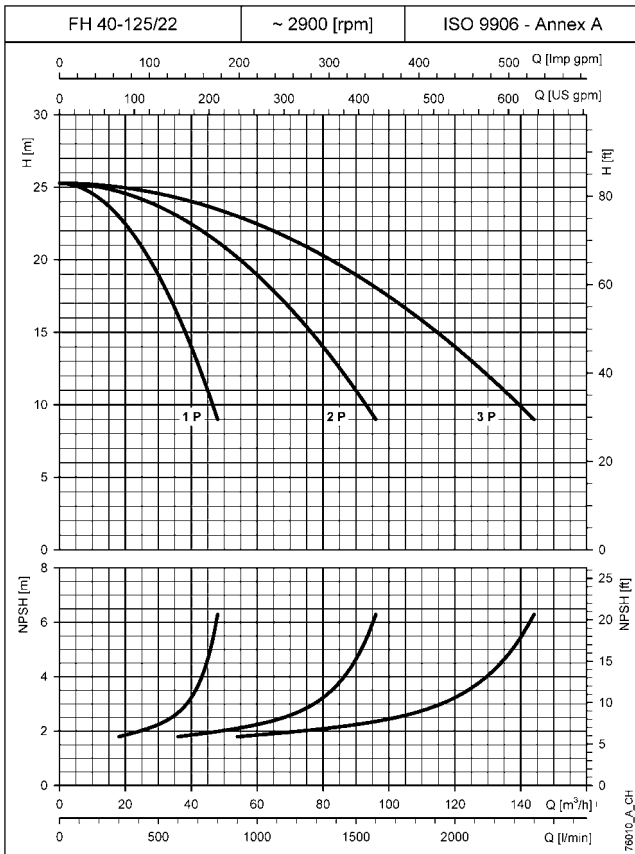
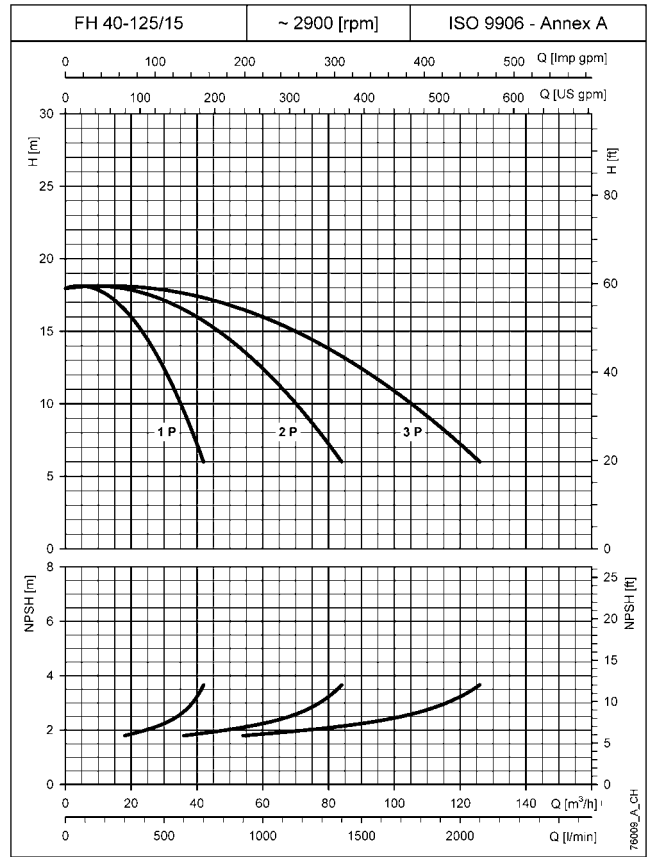
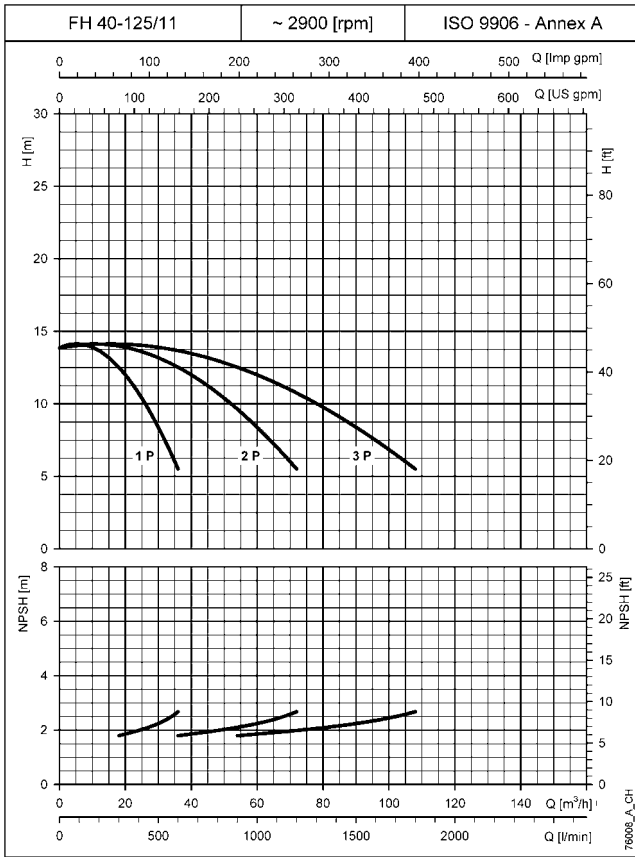

GS.../FH

The performance curves do not take into account flow resistance in the valves and piping.
 The curves show the performance with one, two and three pumps running.
 These performances are valid for liquids with density $\rho = 1.0 \text{ Kg/dm}^3$ and kinematic viscosity $\nu = 1 \text{ mm}^2/\text{s}$.
 The declared NPSH values are laboratory values: for practical use we recommend increasing these values by 0.5 m.

**BOOSTER SETS, GS.../FH SERIES
OPERATING CHARACTERISTICS AT 50 Hz (SERVICE PUMP)**

GS.../FH

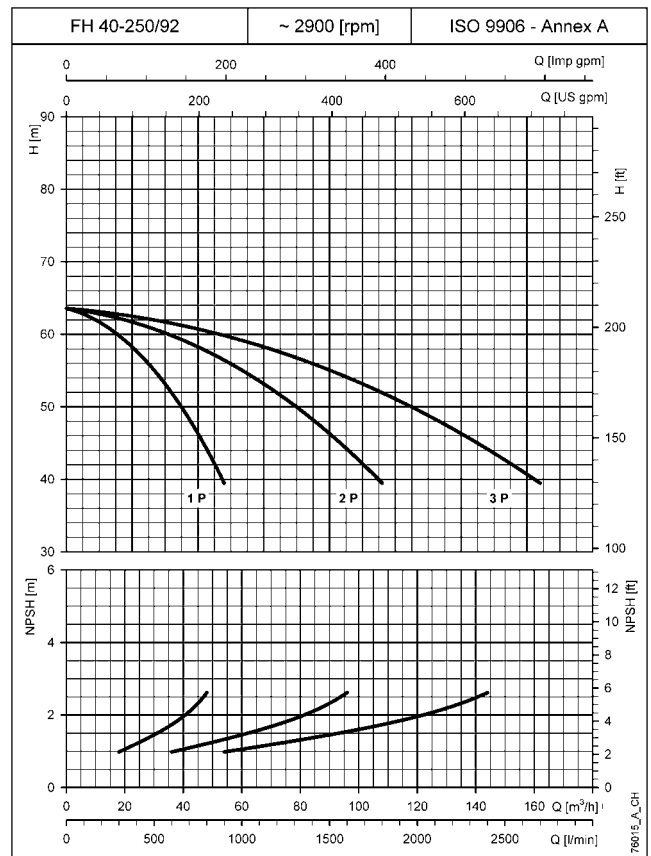
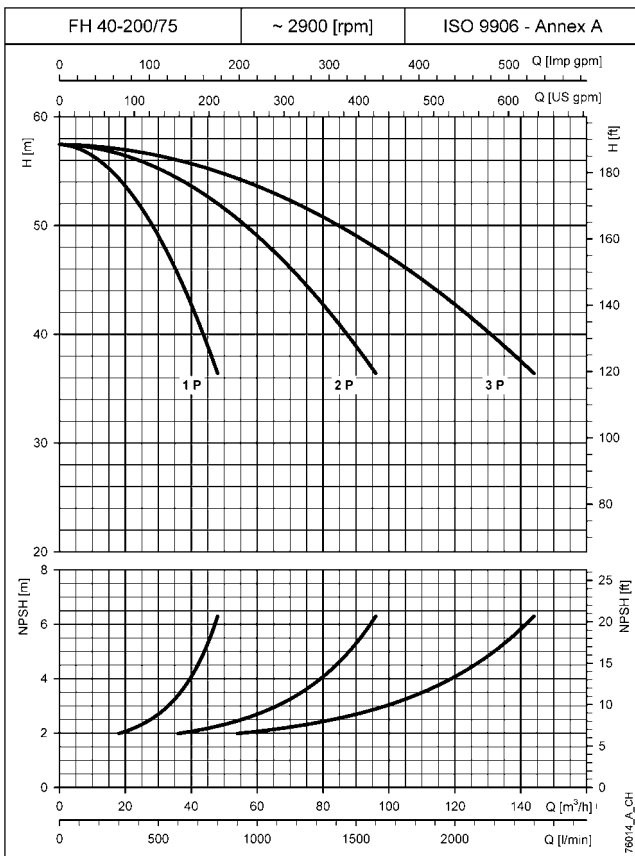
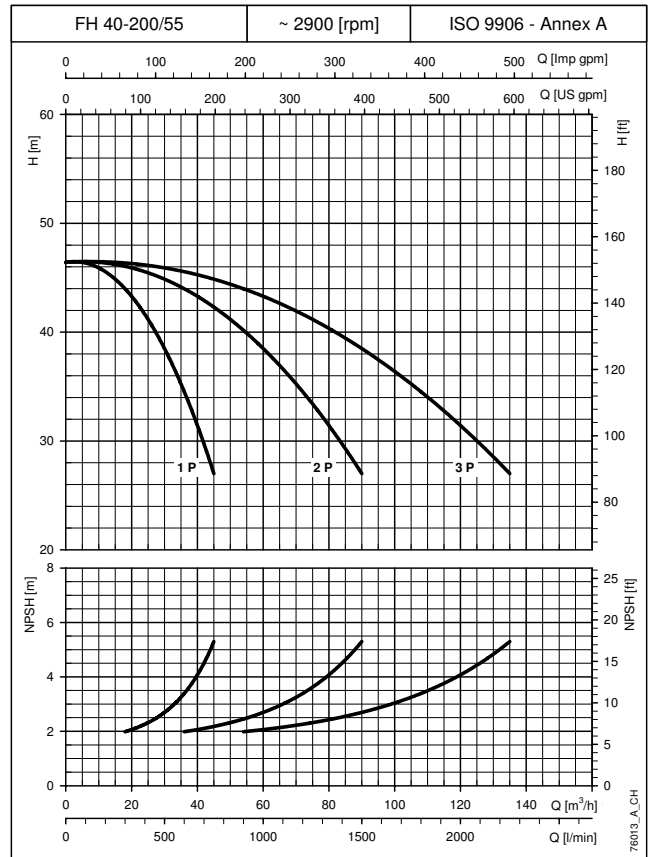
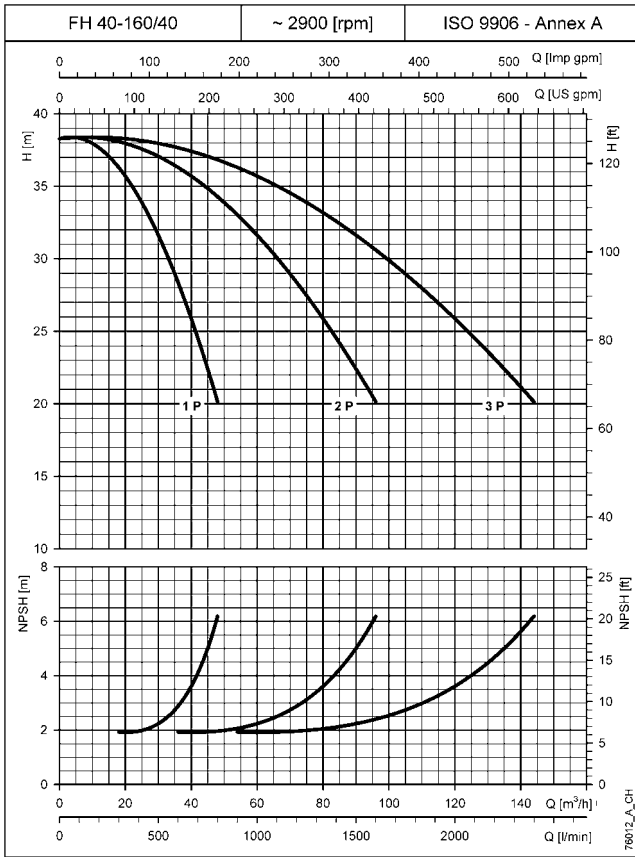

The performance curves do not take into account flow resistance in the valves and piping.
 The curves show the performance with one, two and three pumps running.
 These performances are valid for liquids with density $\rho = 1.0 \text{ Kg/dm}^3$ and kinematic viscosity $\nu = 1 \text{ mm}^2/\text{s}$.
 The declared NPSH values are laboratory values: for practical use we recommend increasing these values by 0.5 m.

**BOOSTER SETS, GS.../FH SERIES
OPERATING CHARACTERISTICS AT 50 Hz (SERVICE PUMP)**

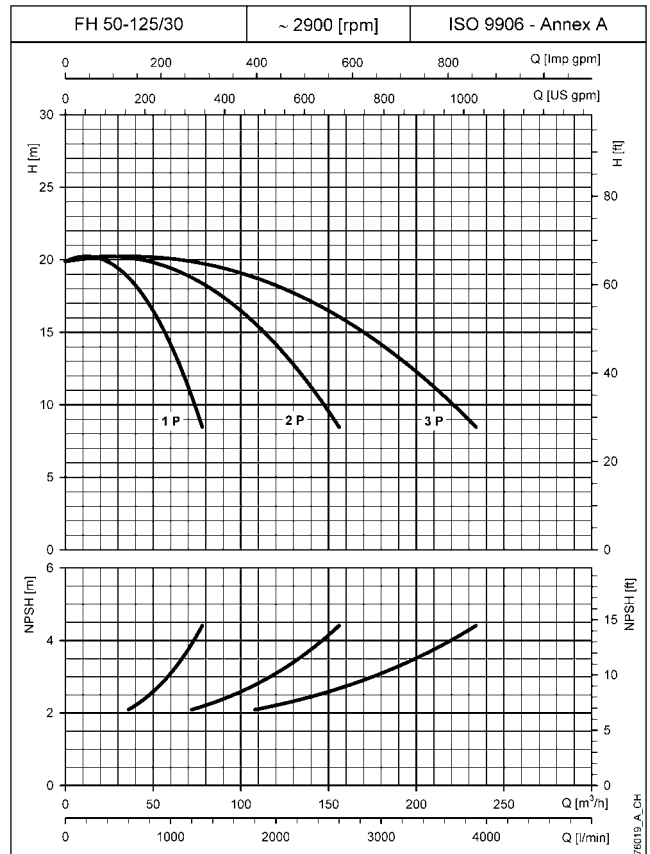
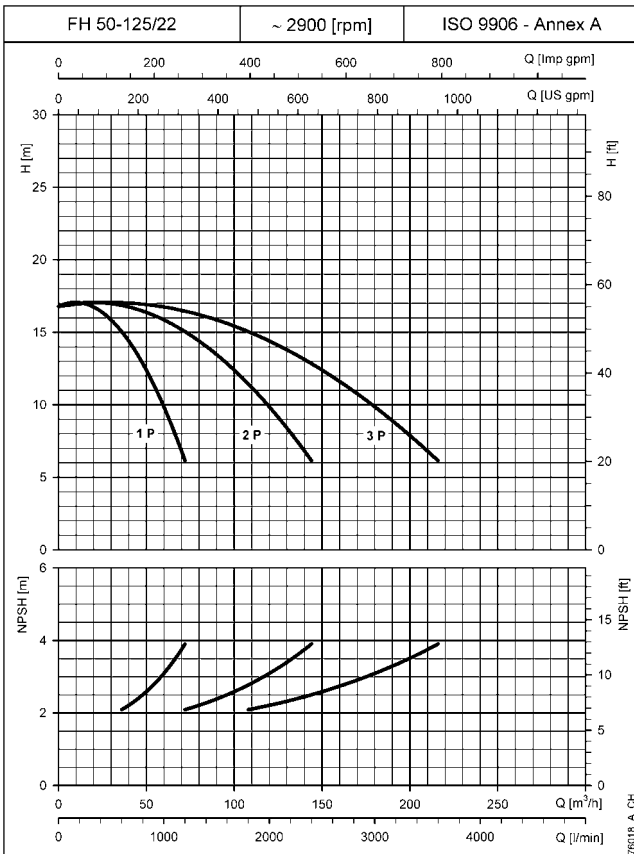
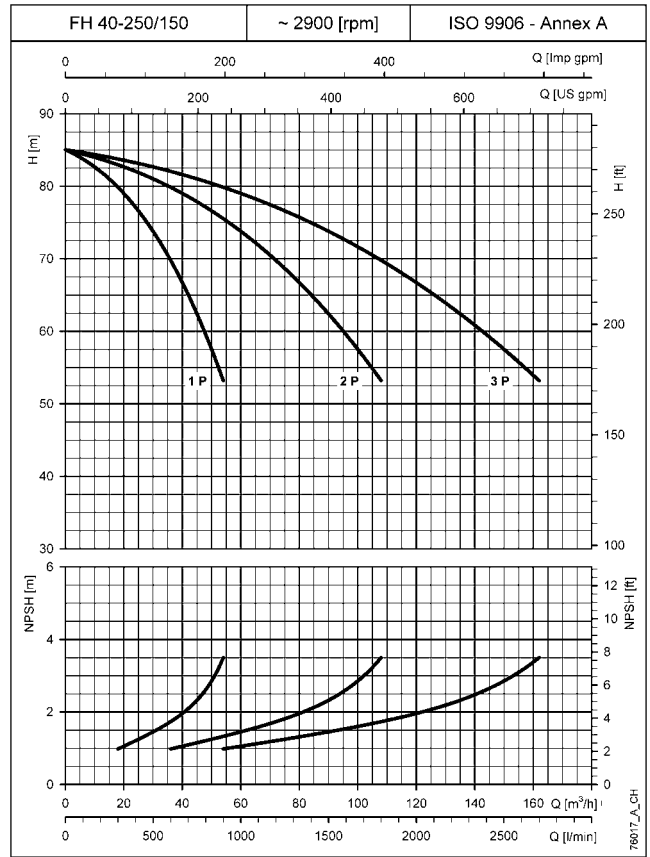
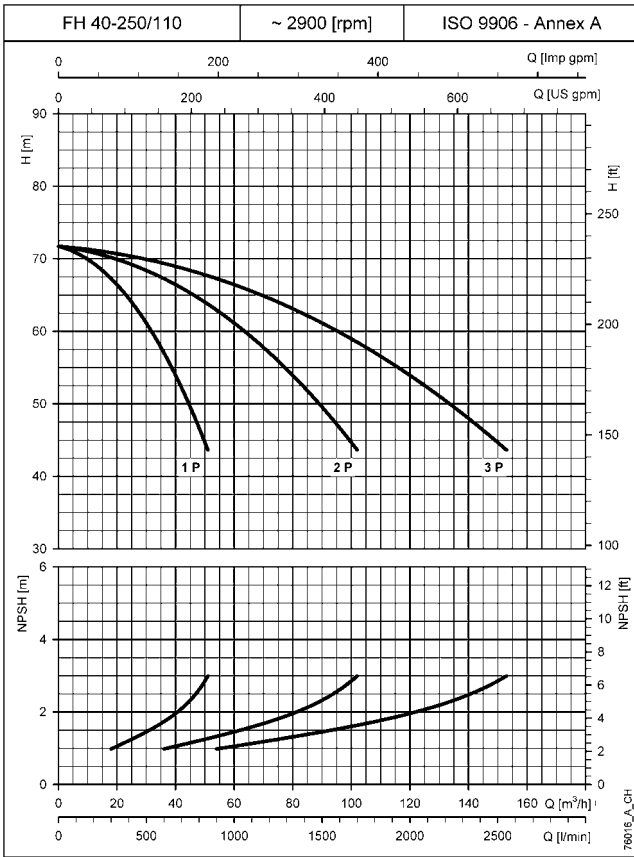

The performance curves do not take into account flow resistance in the valves and piping.
 These performances are valid for liquids with density $\rho = 1.0 \text{ Kg/dm}^3$ and kinematic viscosity $\nu = 1 \text{ mm}^2/\text{s}$.
 The declared NPSH values are laboratory values: for practical use we recommend increasing these values by 0.5 m.

GS.../FH

**BOOSTER SETS, GS.../FH SERIES
OPERATING CHARACTERISTICS AT 50 Hz (SERVICE PUMP)**

GS.../FH

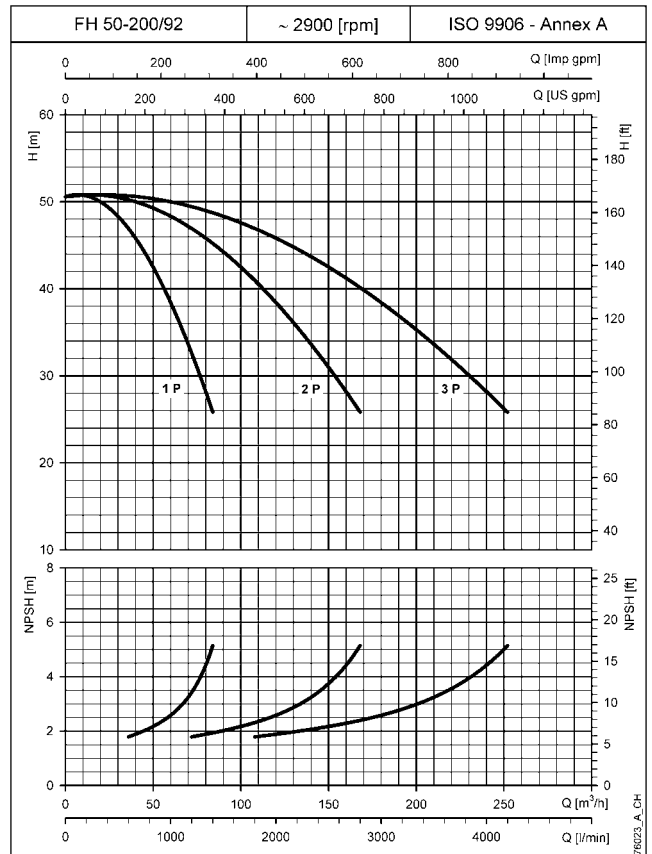
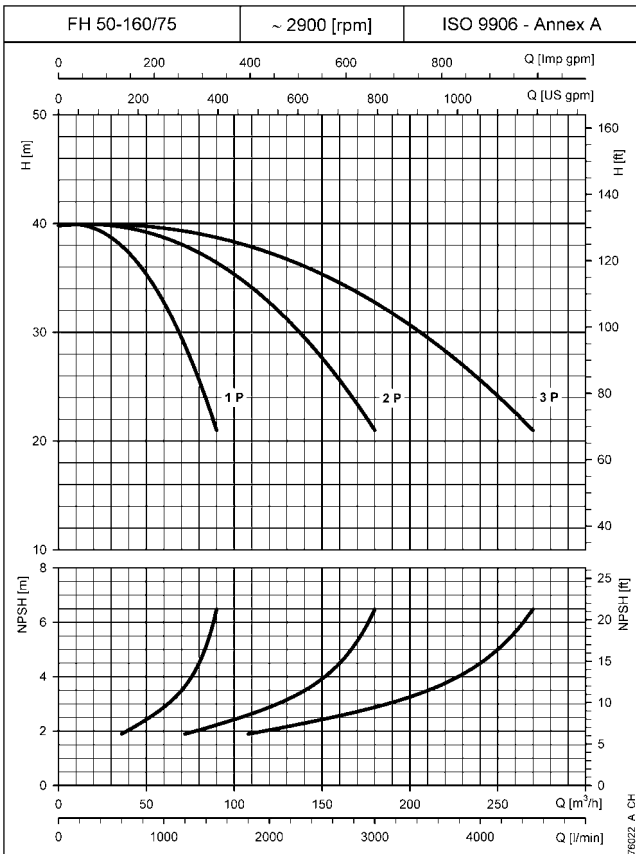
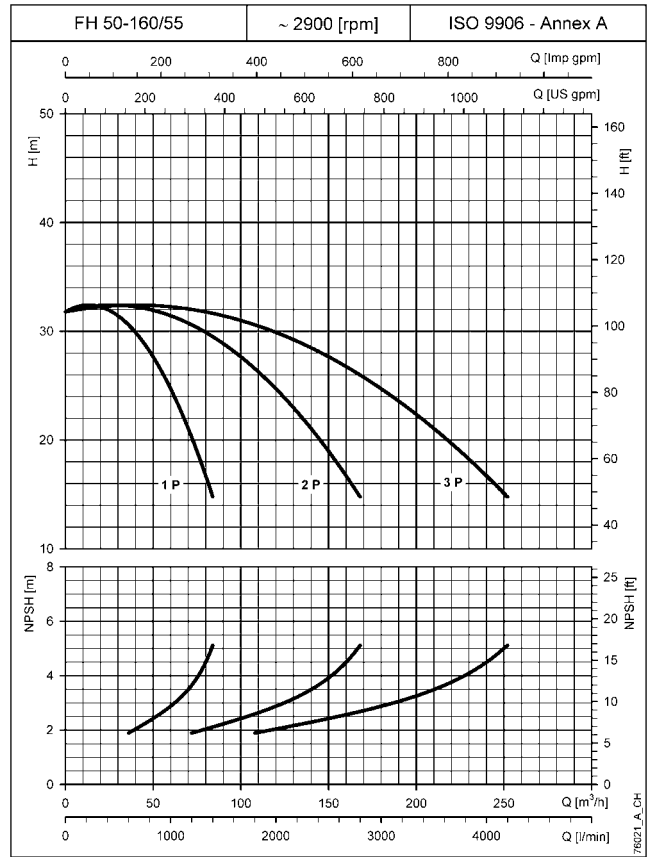
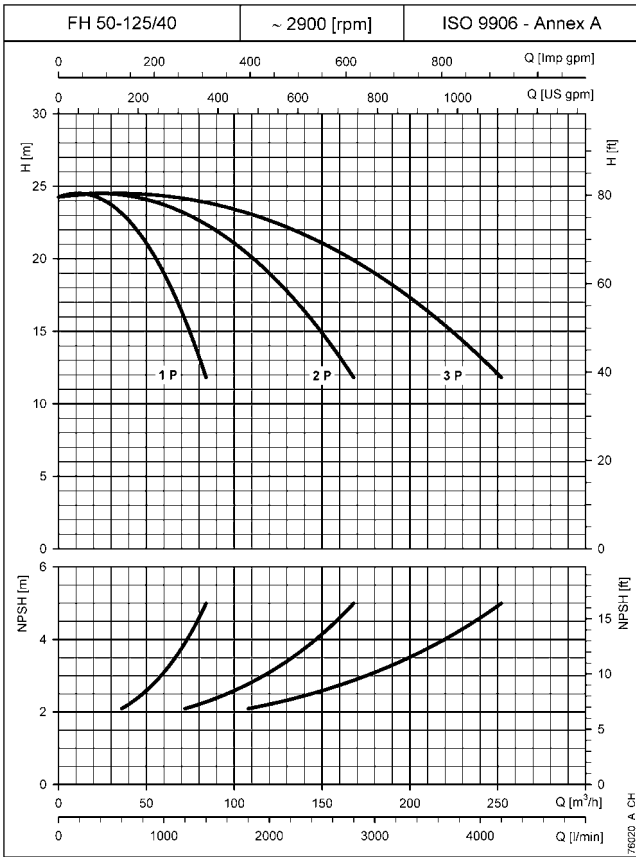

The performance curves do not take into account flow resistance in the valves and piping.
The curves show the performance with one, two and three pumps running.
These performances are valid for liquids with density $\rho = 1.0 \text{ Kg/dm}^3$ and kinematic viscosity $\nu = 1 \text{ mm}^2/\text{s}$.
The declared NPSH values are laboratory values: for practical use we recommend increasing these values by 0.5 m.

BOOSTER SETS, GS.../FH SERIES OPERATING CHARACTERISTICS AT 50 Hz (SERVICE PUMP)

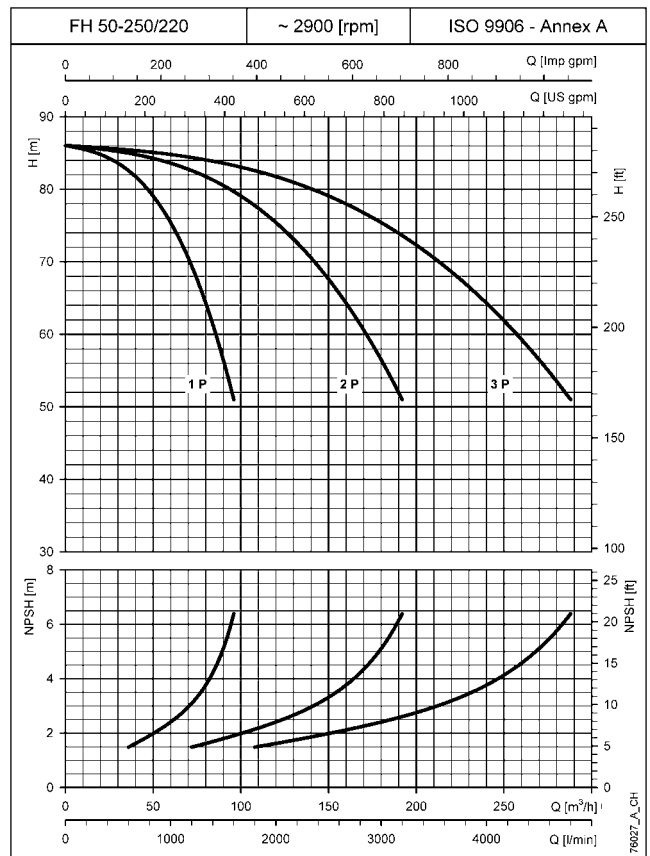
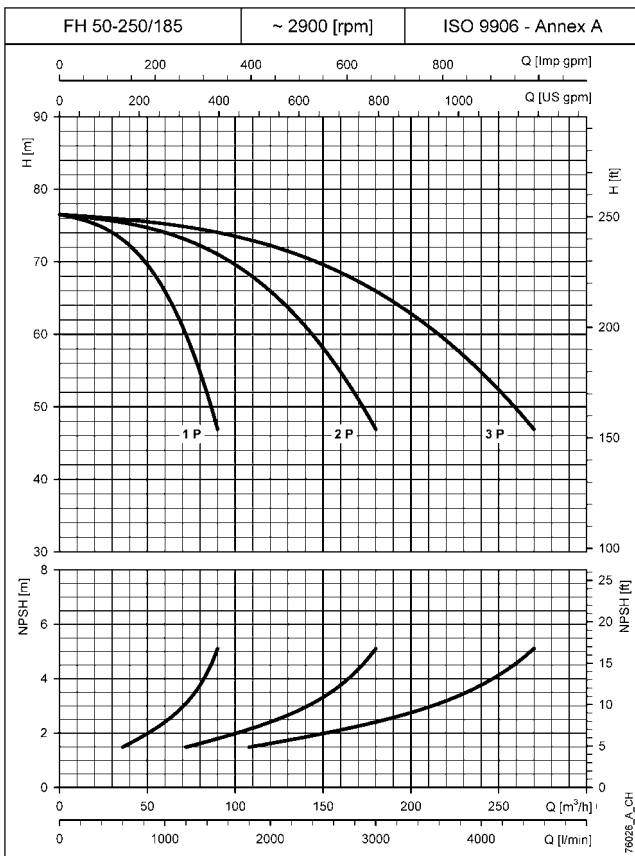
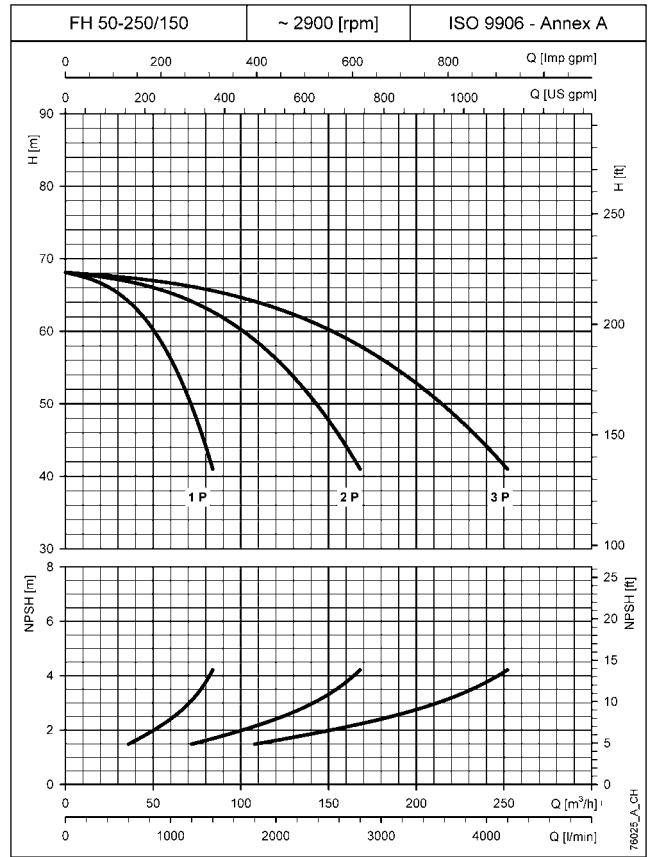
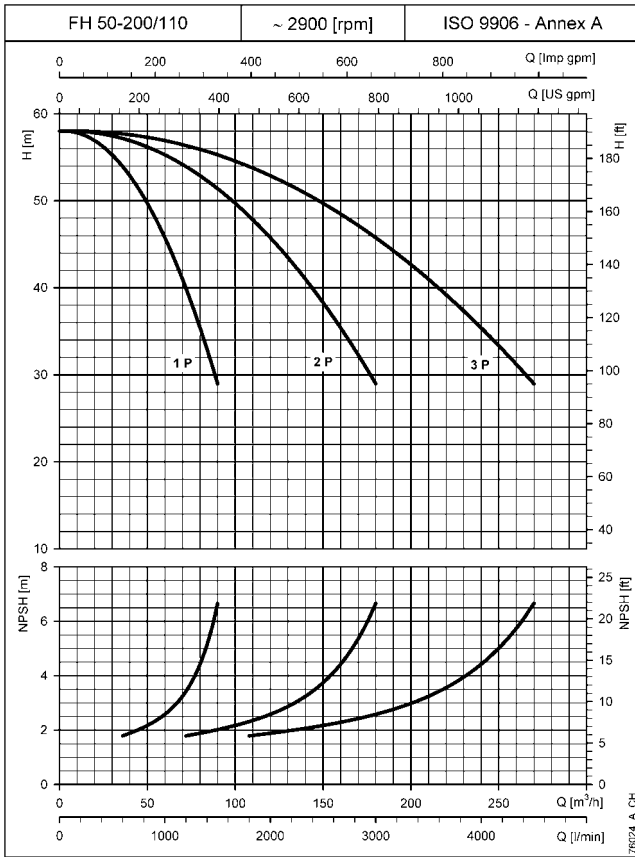

GS.../FH

The performance curves do not take into account flow resistance in the valves and piping.
 The curves show the performance with one, two and three pumps running.
 These performances are valid for liquids with density $\rho = 1.0 \text{ Kg/dm}^3$ and kinematic viscosity $\nu = 1 \text{ mm}^2/\text{s}$.
 The declared NPSH values are laboratory values: for practical use we recommend increasing these values by 0.5 m.

**BOOSTER SETS, GS.../FH SERIES
OPERATING CHARACTERISTICS AT 50 Hz (SERVICE PUMP)**

GS.../FH

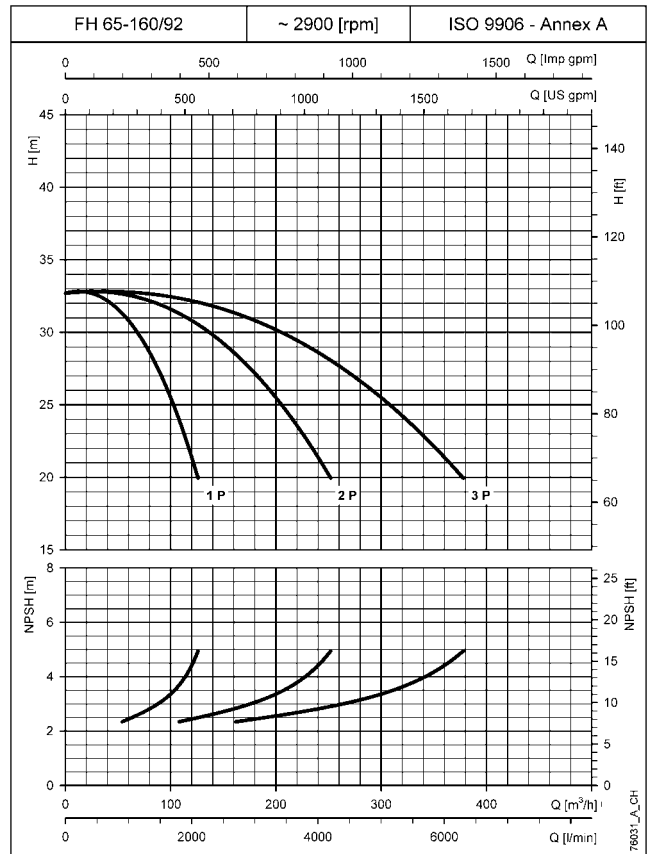
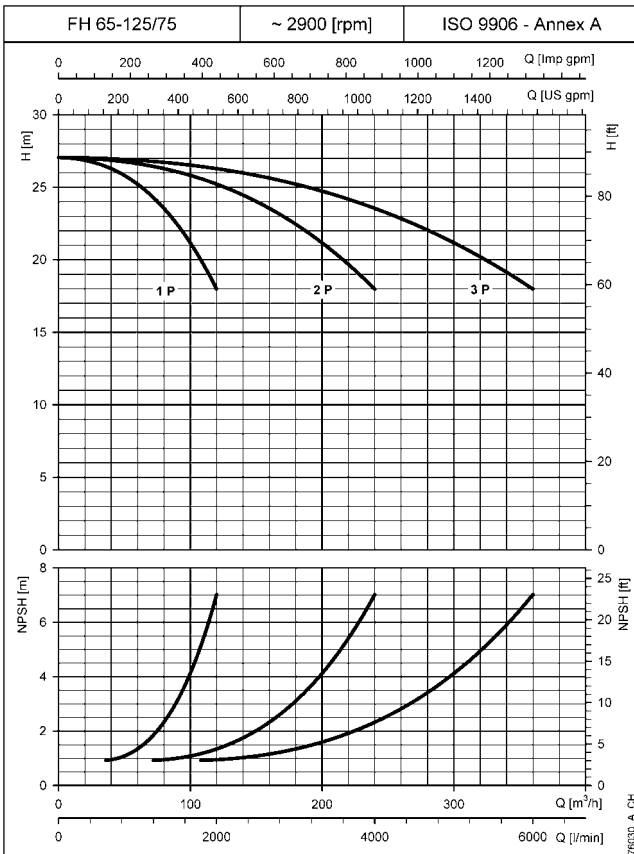
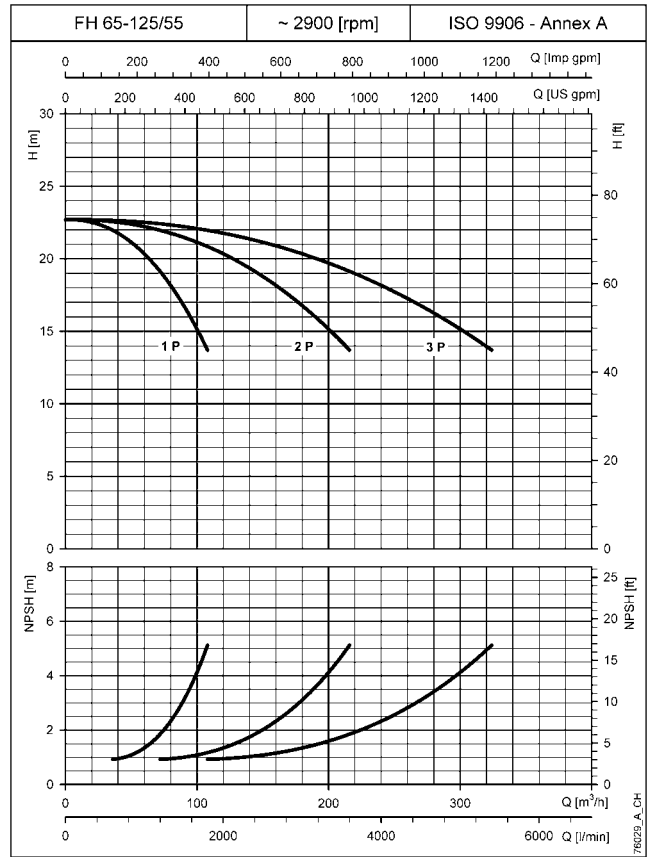
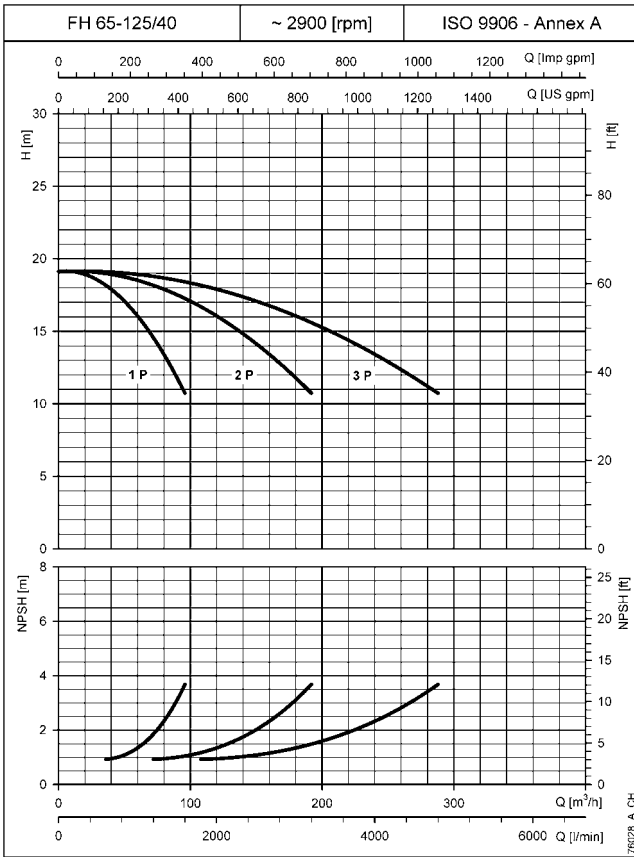

The performance curves do not take into account flow resistance in the valves and piping.
The curves show the performance with one, two and three pumps running.
These performances are valid for liquids with density $\rho = 1.0 \text{ Kg/dm}^3$ and kinematic viscosity $\nu = 1 \text{ mm}^2/\text{s}$.
The declared NPSH values are laboratory values: for practical use we recommend increasing these values by 0.5 m.

**BOOSTER SETS, GS.../FH SERIES
OPERATING CHARACTERISTICS AT 50 Hz (SERVICE PUMP)**

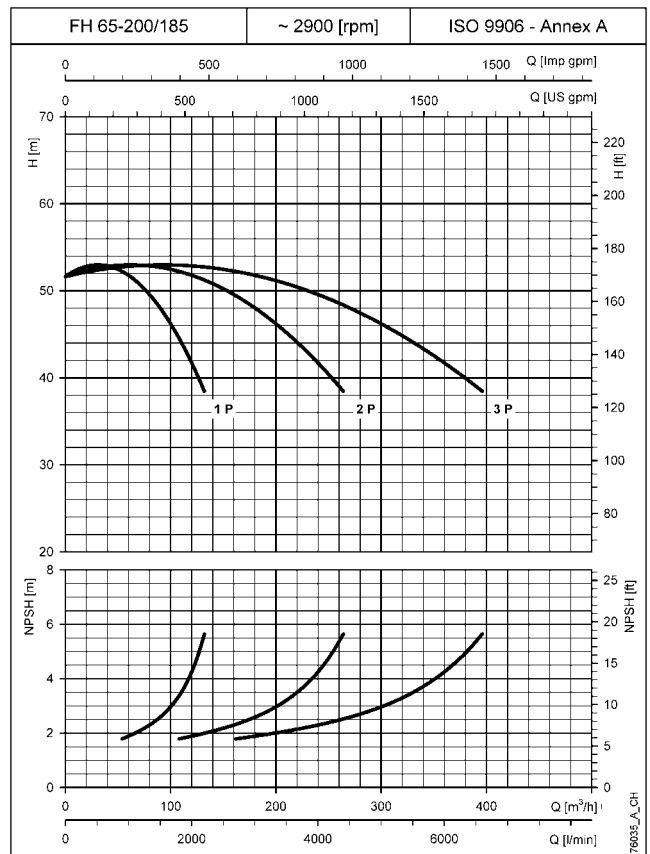
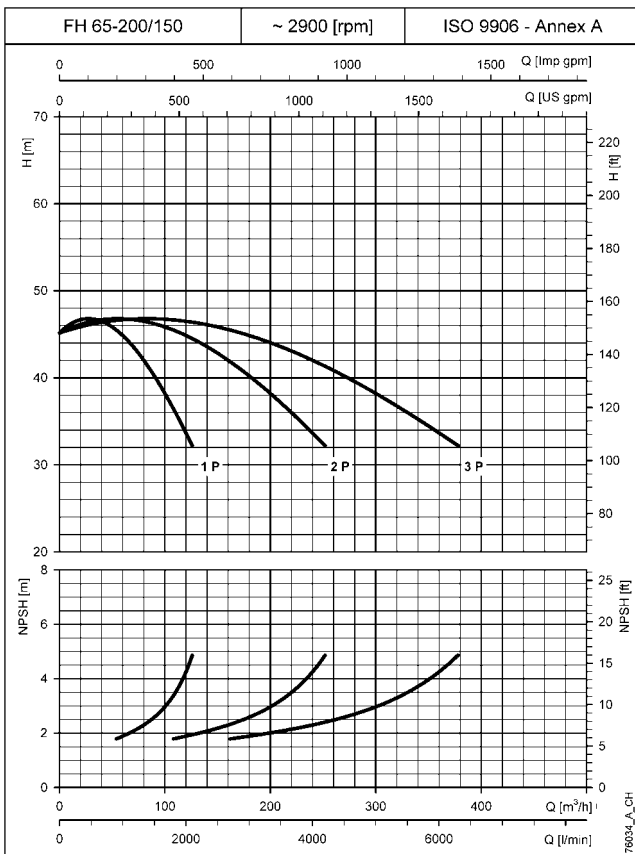
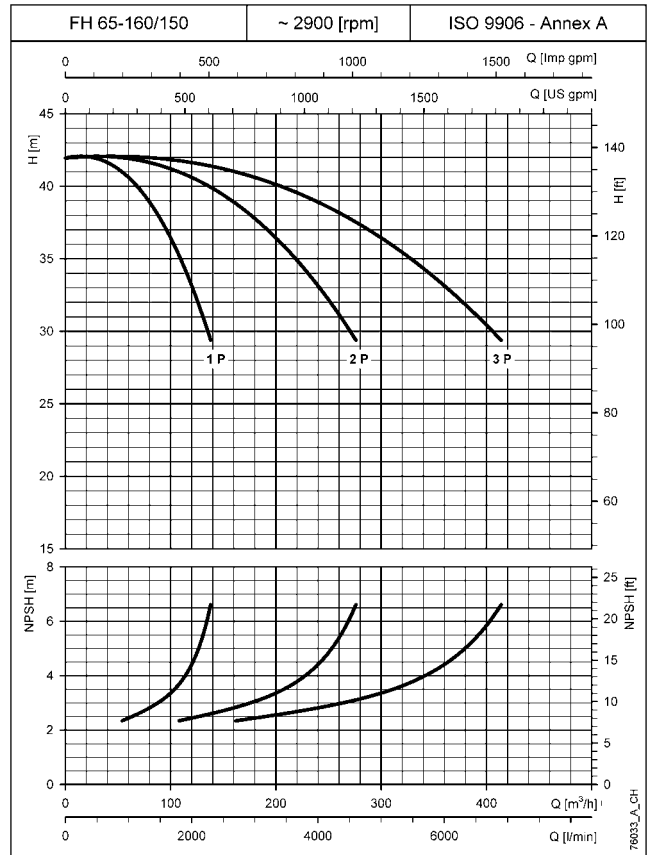
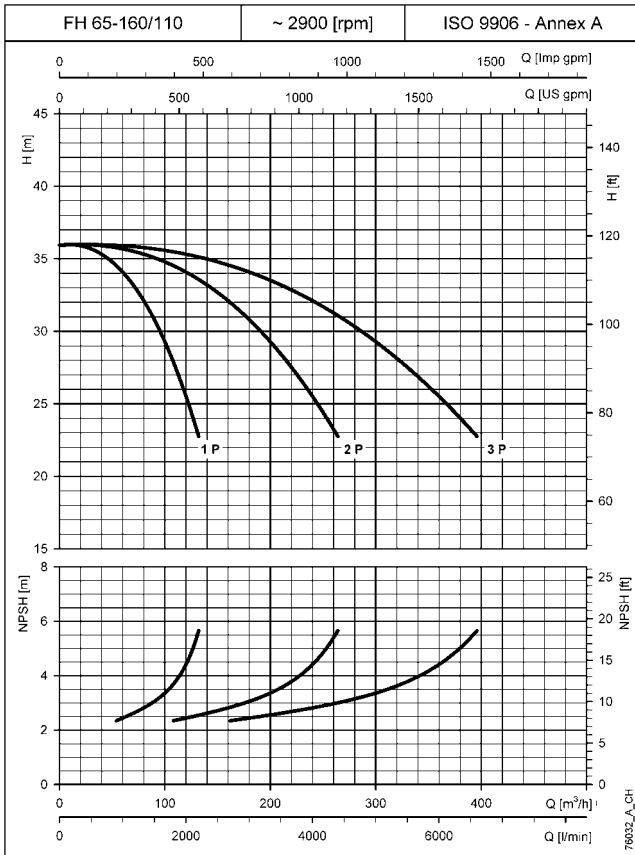

GS.../FH

The performance curves do not take into account flow resistance in the valves and piping.
The curves show the performance with one, two and three pumps running.
These performances are valid for liquids with density $\rho = 1.0 \text{ Kg/dm}^3$ and kinematic viscosity $\nu = 1 \text{ mm}^2/\text{s}$.
The declared NPSH values are laboratory values; for practical use we recommend increasing these values by 0.5 m.

**BOOSTER SETS, GS.../FH SERIES
OPERATING CHARACTERISTICS AT 50 Hz (SERVICE PUMP)**

GS.../FH

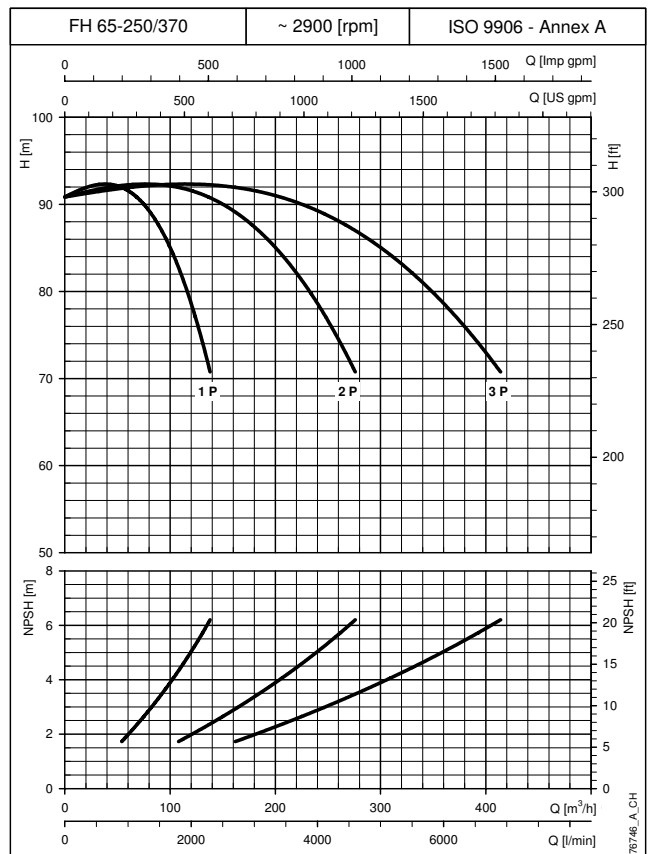
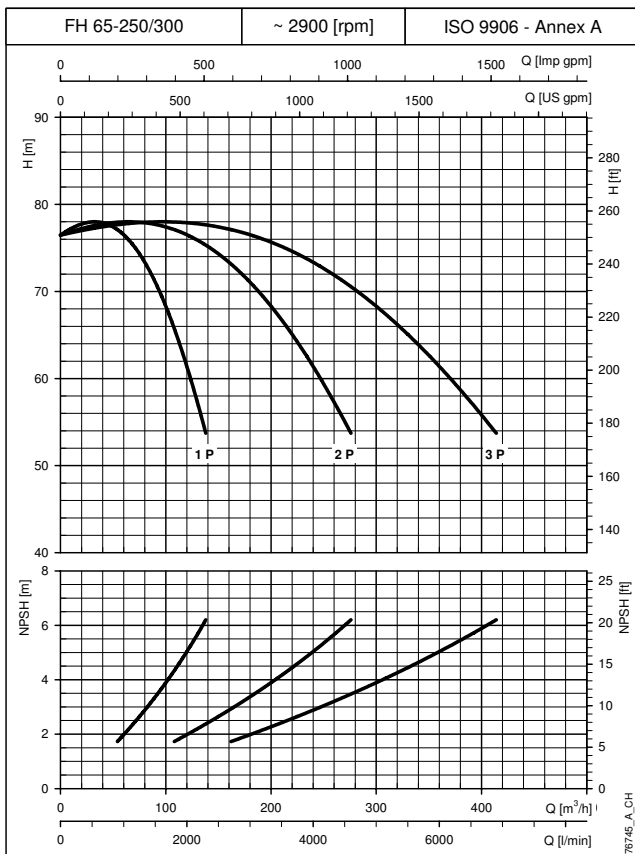
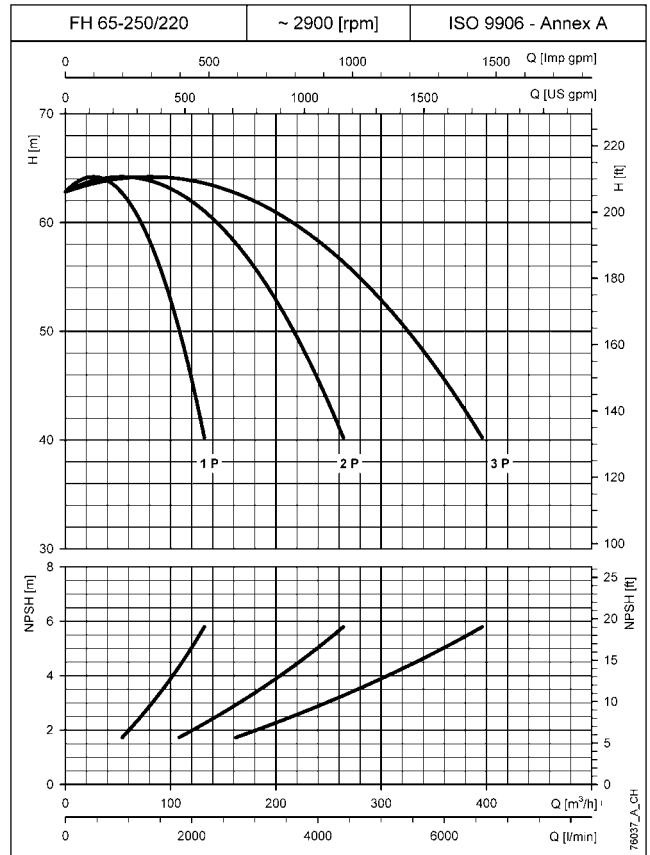
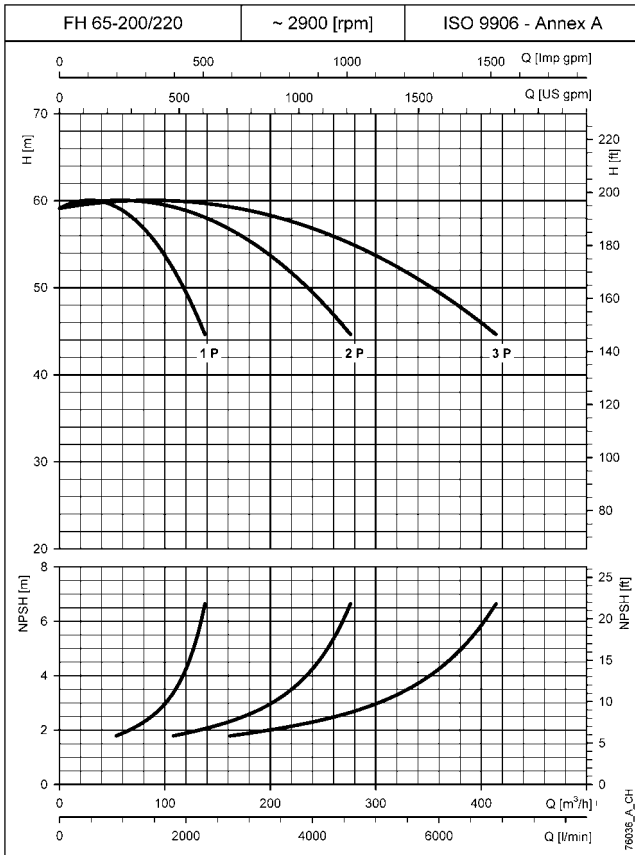

The performance curves do not take into account flow resistance in the valves and piping.
 The curves show the performance with one, two and three pumps running.
 These performances are valid for liquids with density $\rho = 1.0 \text{ Kg/dm}^3$ and kinematic viscosity $\nu = 1 \text{ mm}^2/\text{s}$.
 The declared NPSH values are laboratory values: for practical use we recommend increasing these values by 0.5 m.

**BOOSTER SETS, GS.../FH SERIES
OPERATING CHARACTERISTICS AT 50 Hz (SERVICE PUMP)**

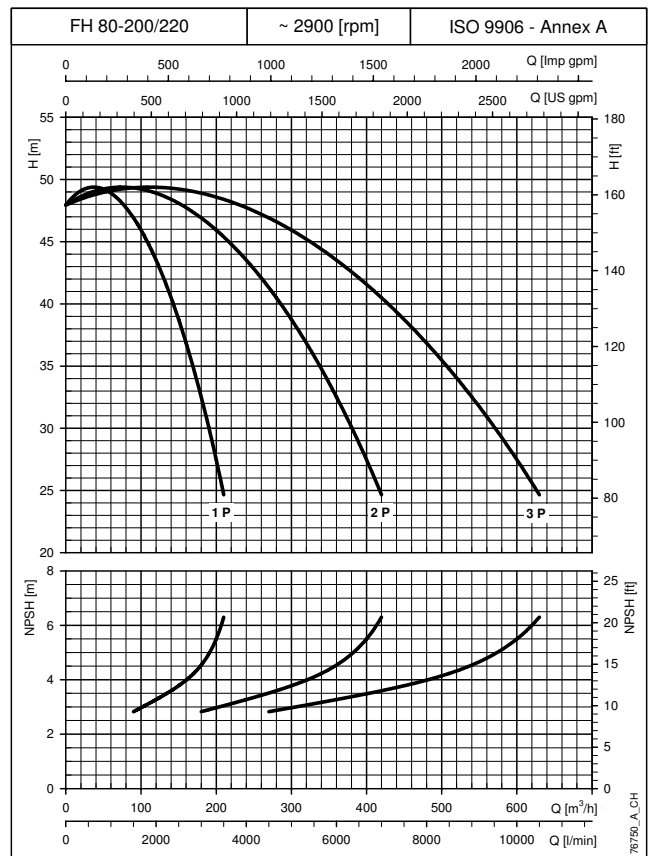
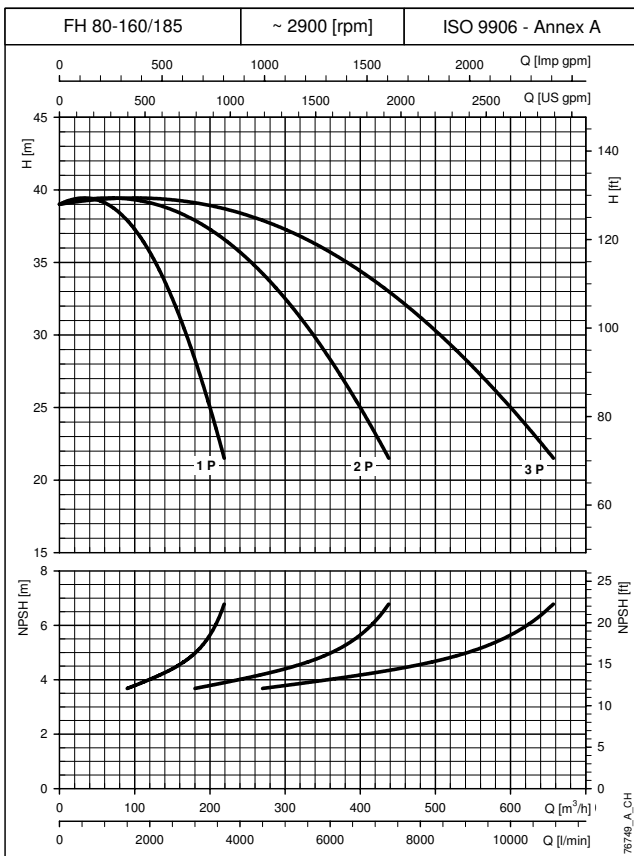
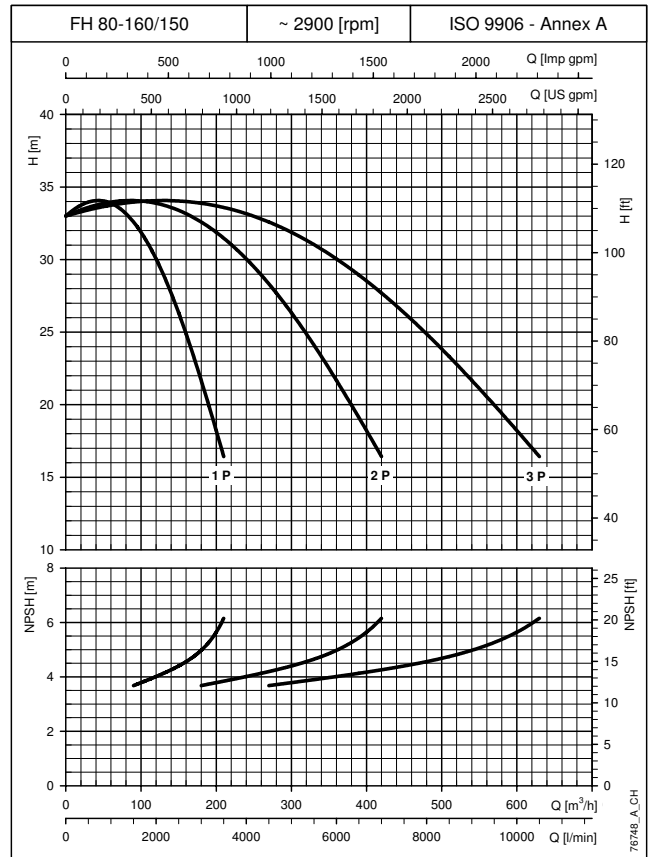
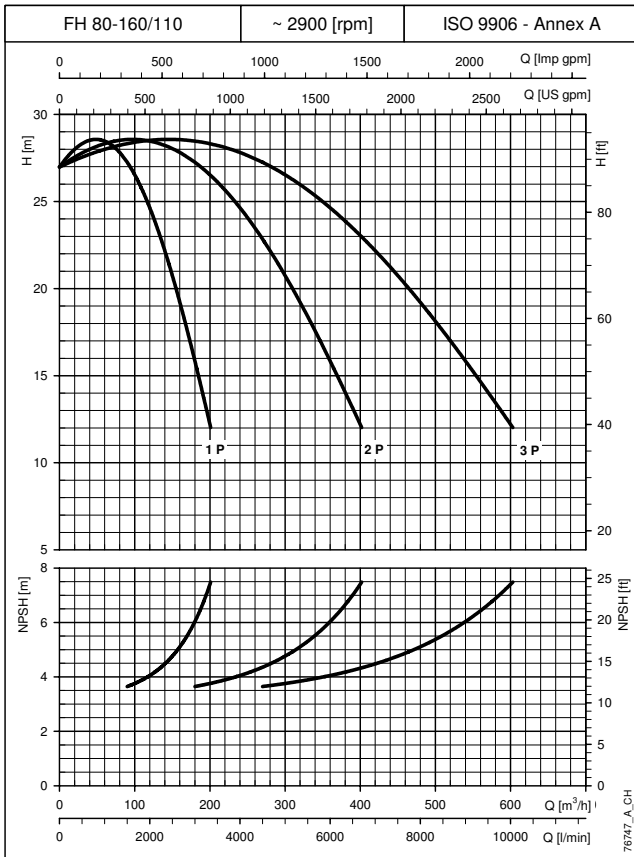

GS.../FH

The performance curves do not take into account flow resistance in the valves and piping.
 The curves show the performance with one, two and three pumps running.
 These performances are valid for liquids with density $\rho = 1.0 \text{ Kg/dm}^3$ and kinematic viscosity $\nu = 1 \text{ mm}^2/\text{s}$.
 The declared NPSH values are laboratory values: for practical use we recommend increasing these values by 0.5 m.

**BOOSTER SETS, GS.../FH SERIES
OPERATING CHARACTERISTICS AT 50 Hz (SERVICE PUMP)**

GS.../FH

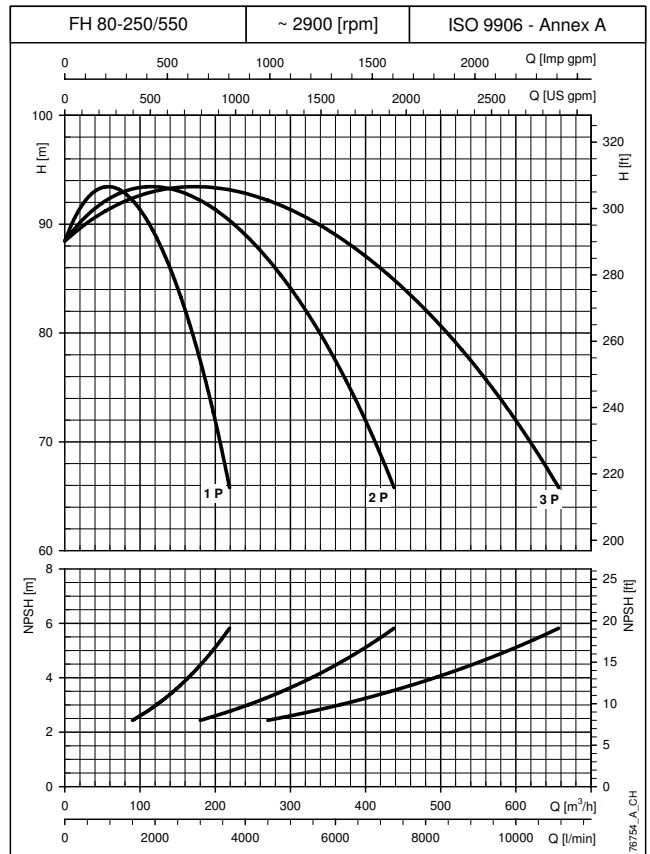
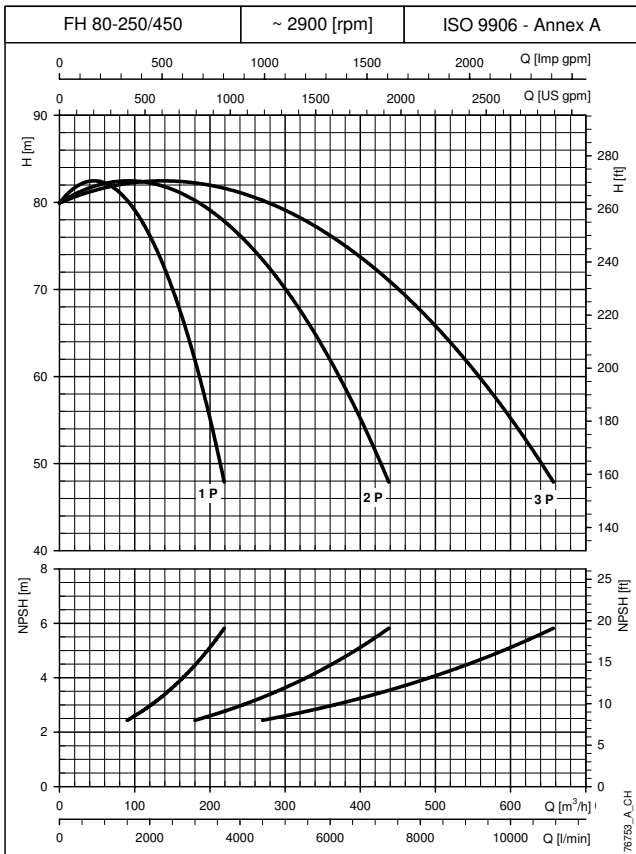
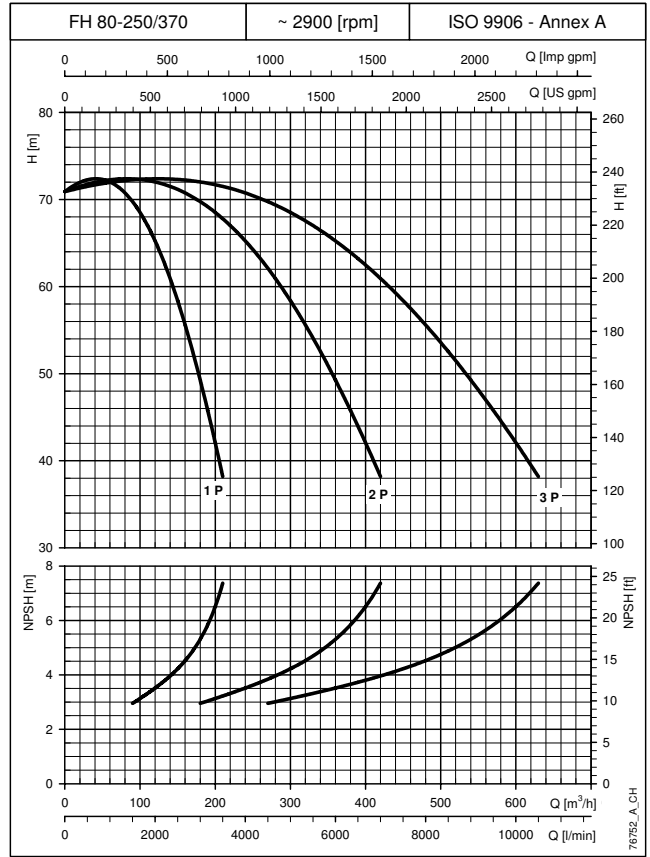
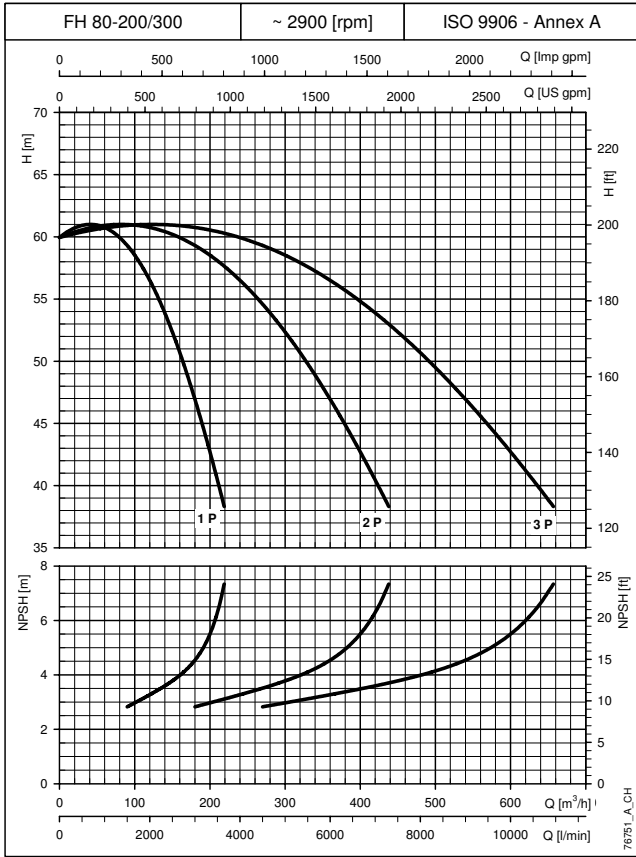

The performance curves do not take into account flow resistance in the valves and piping.
 The curves show the performance with one, two and three pumps running.
 These performances are valid for liquids with density $\rho = 1.0 \text{ Kg/dm}^3$ and kinematic viscosity $\nu = 1 \text{ mm}^2/\text{s}$.
 The declared NPSH values are laboratory values: for practical use we recommend increasing these values by 0.5 m.

BOOSTER SETS, GS.../FH SERIES
H_c PRESSURE DROP CURVE

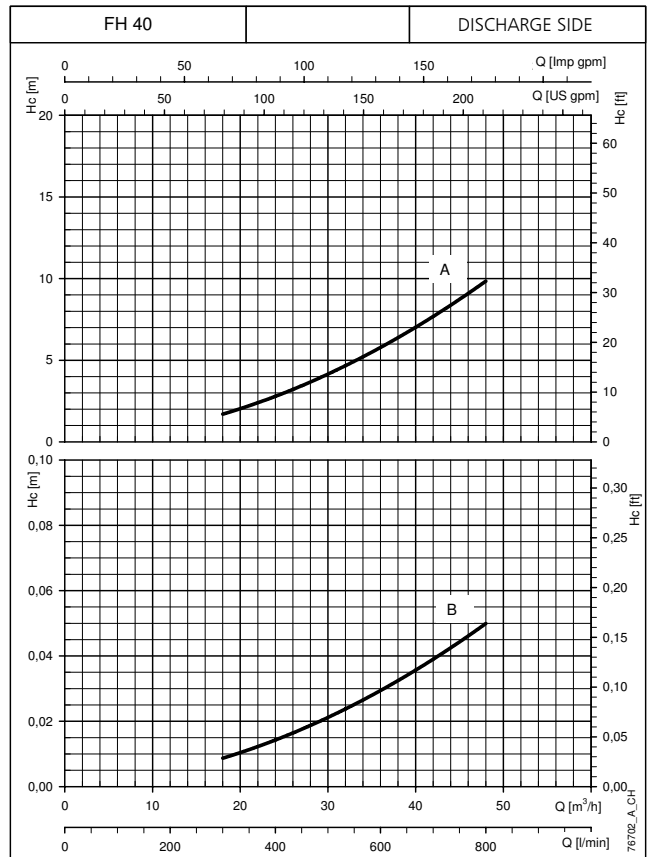
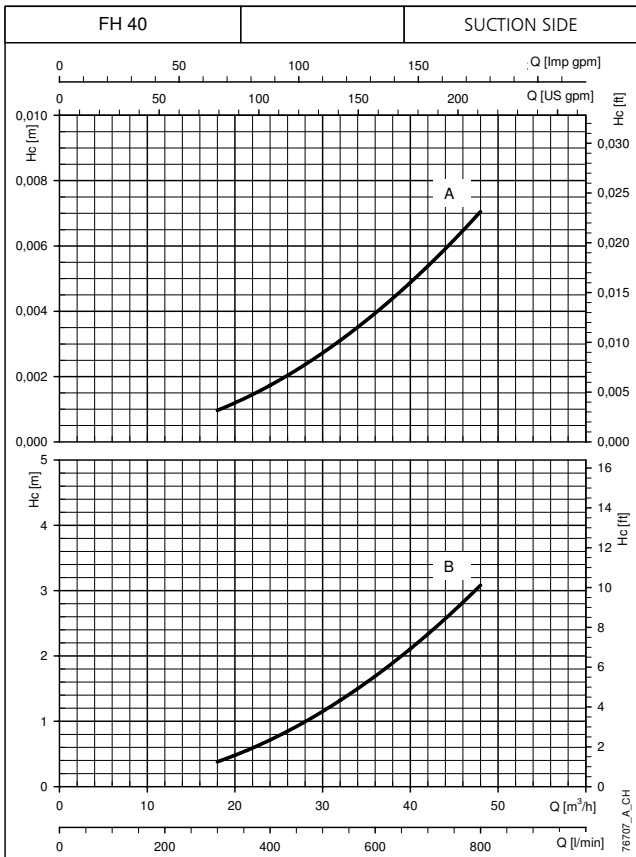
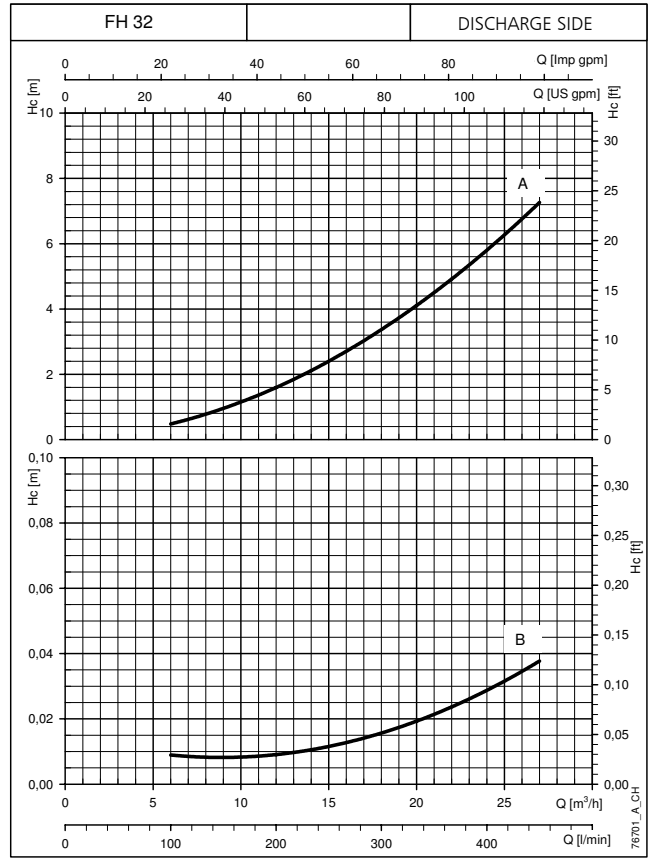
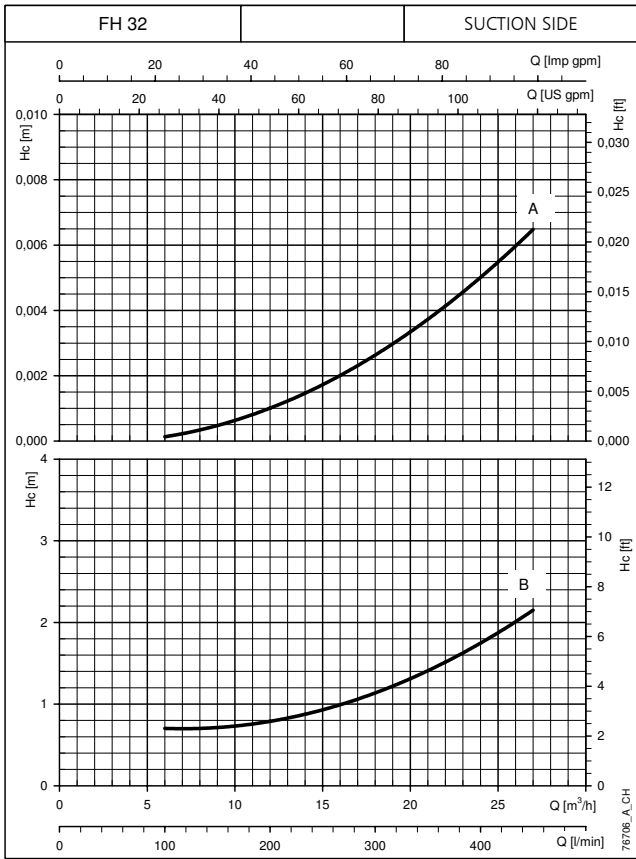

The declared curves are valid for liquids with density $\rho = 1.0 \text{ Kg/dm}^3$ and kinematic viscosity $\nu = 1 \text{ mm}^2/\text{sec}$.
 H_c (A): Pressure drop curve with check valve installed on the delivery side of the pump.
 H_c (B): Pressure drop curve with check valve installed on the suction side of the pump.
 The pressure drops do not consider the pressure drops distributed in the manifold.

GS.../FH

BOOSTER SETS, GS.../FH SERIES
H_c PRESSURE DROP CURVE

GS.../FH

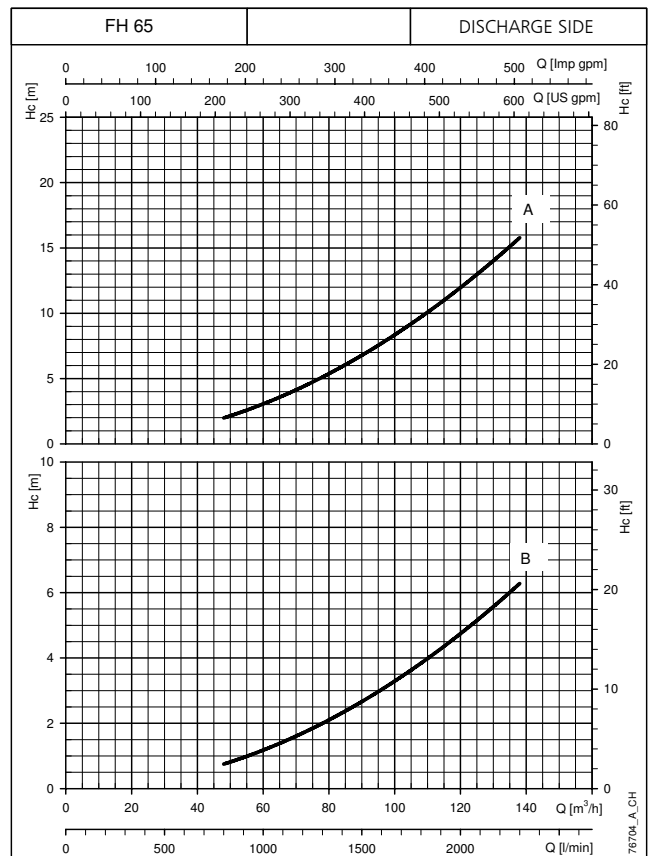
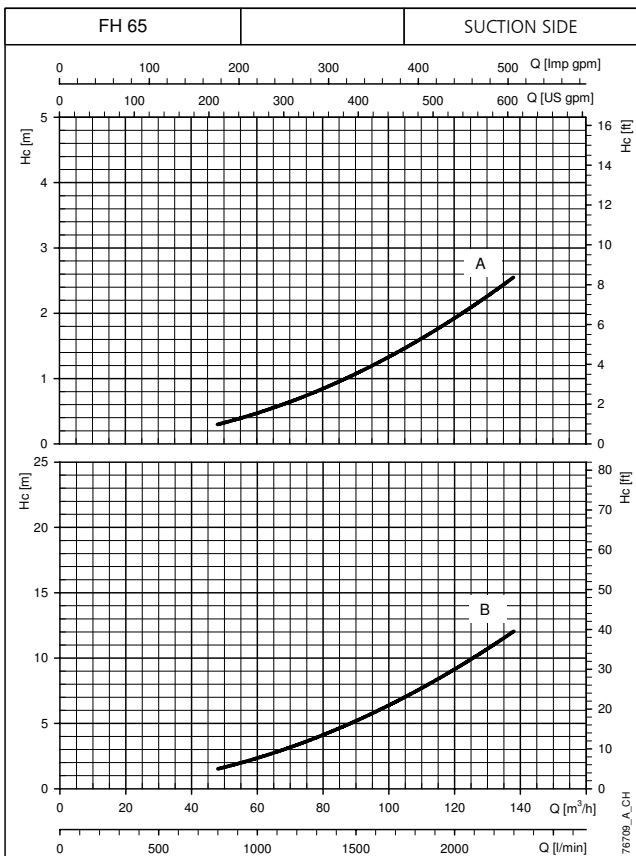
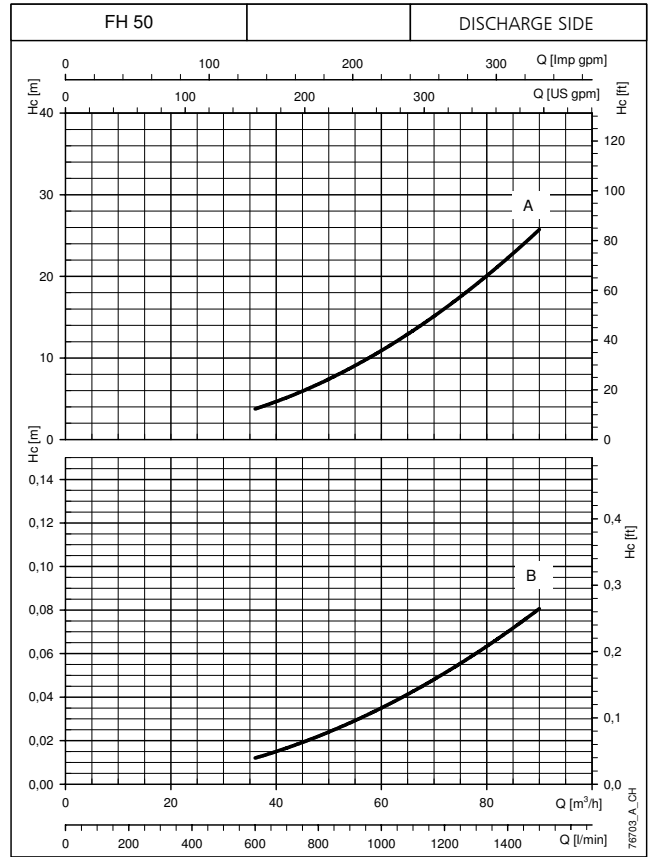
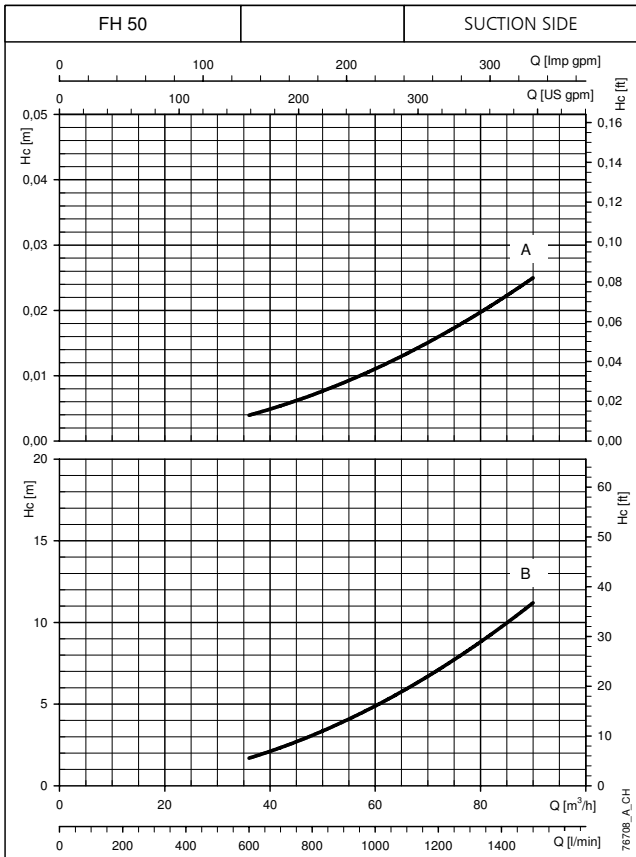

The declared curves are valid for liquids with density $\rho = 1.0 \text{ Kg/dm}^3$ and kinematic viscosity $\nu = 1 \text{ mm}^2/\text{sec}$.
 H_c (A): Pressure drop curve with check valve installed on the delivery side of the pump.
 H_c (B): Pressure drop curve with check valve installed on the suction side of the pump.
 The pressure drops do not consider the pressure drops distributed in the manifold.

BOOSTER SETS, GS.../FH SERIES
H_c PRESSURE DROP CURVE

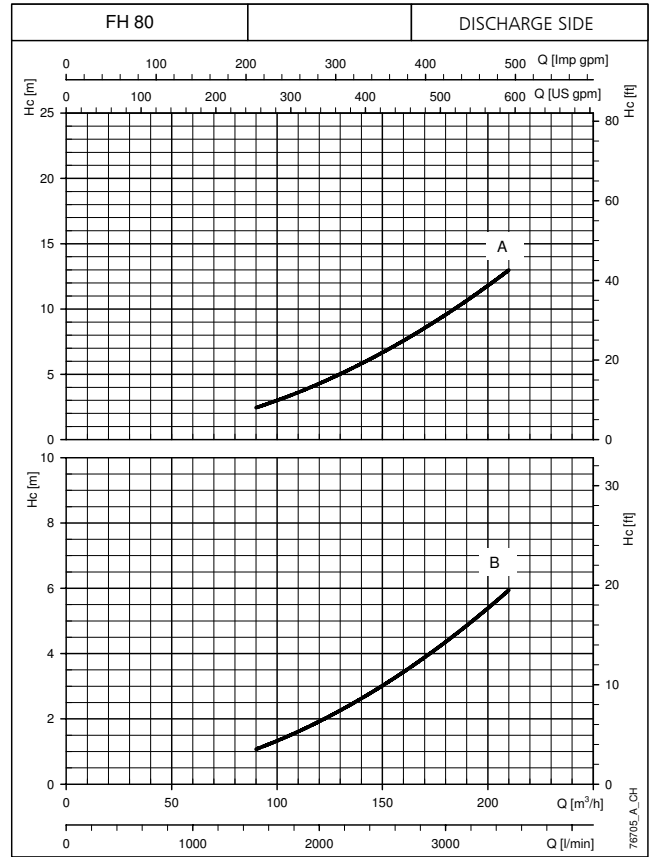
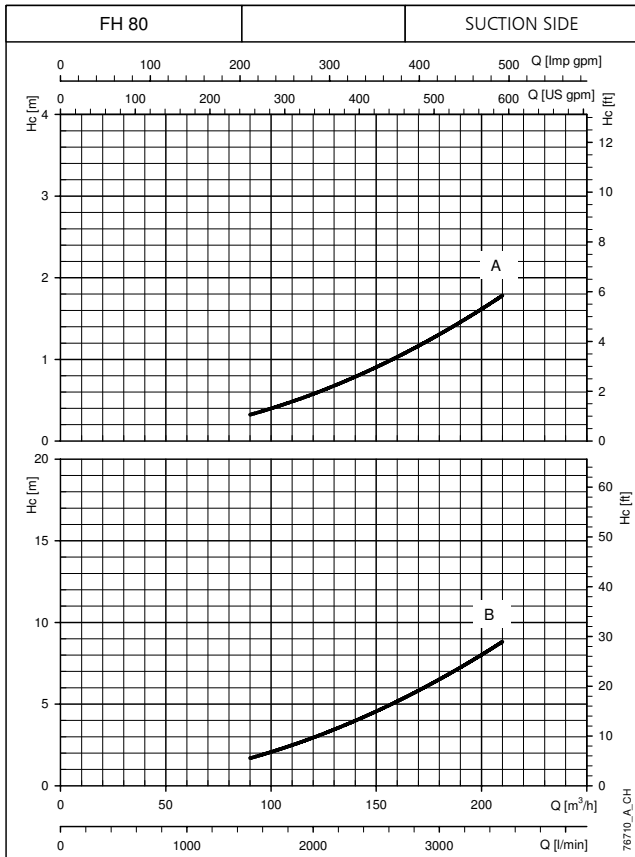

The declared curves are valid for liquids with density $\rho = 1.0 \text{ Kg/dm}^3$ and kinematic viscosity $\nu = 1 \text{ mm}^2/\text{sec}$.
Hc (A): Pressure drop curve with check valve installed on the delivery side of the pump.
Hc (B): Pressure drop curve with check valve installed on the suction side of the pump.
The pressure drops do not consider the pressure drops distributed in the manifold.

GS.../FH

GS.../SH Series

Fixed-speed pressure booster sets
Horizontal Centrifugal electric pumps SH series
in AISI 316 Stainless Steel in compliance EN 733
equipped with high efficiency motors
flow rate up to 667 m³/h

50 Hz

GS.../SH SERIES
HYDRAULIC PERFORMANCE RANGE AT 50 Hz

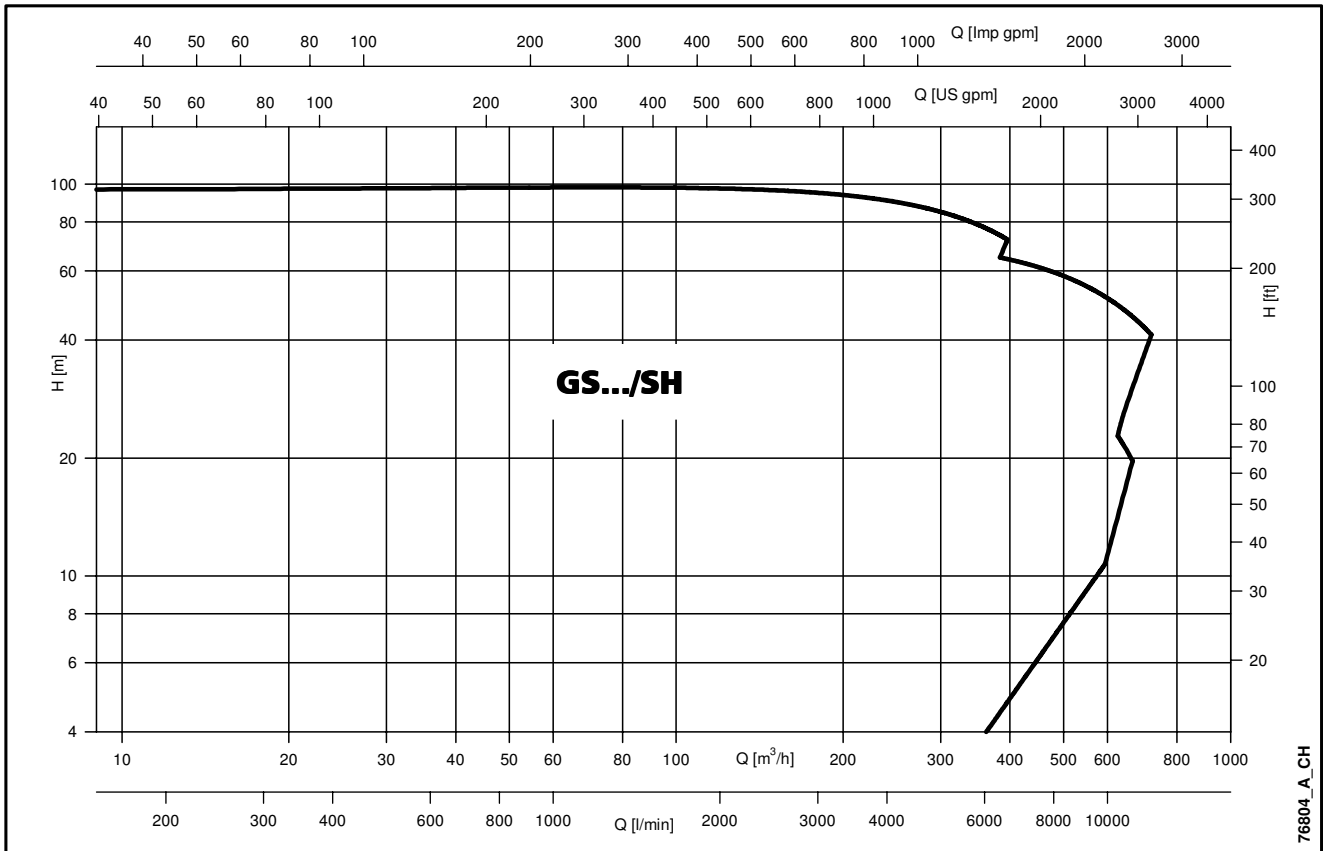

GS.../SH

76804_A_CH

RANGE

The GS series of fixed-speed pressure boosters comprises models with 2 or 3 electric service pumps and an optional jockey pump in order to satisfy the specific needs of every application.

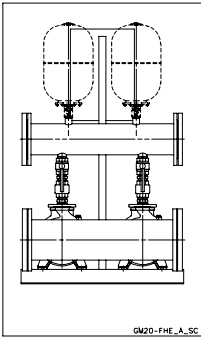

GS20 SETS

- Fixed-speed sets with two horizontal service pumps, SH series, with power ratings up to 37 kW.

Head up to 100m.
Flow rate up to 444 m³/h.

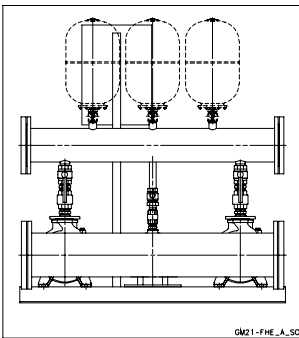

GS21 SETS

- Fixed-speed sets with two service pumps and a jockey pump. Horizontal service electric pumps, SH series, with power ratings up to 37 kW.

Head up to 100m.
Flow rate up to 444 m³/h.

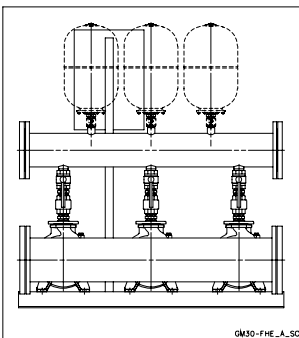

GS30 SETS

- Fixed-speed sets with three horizontal service pumps, SH series, with power ratings up to 37 kW.

Head up to 100m.
Flow rate up to 666 m³/h.

GS.../SH

REFERENCE STANDARDS

- The Lowara booster sets are CE-marked for conformity with the following directives:
 - Machinery Directive: 2006/42/EC.
 - Low Voltage Directive 2006/95/EC.
 - Electromagnetic Compatibility Directive 2004/108/EC
- Electric pump performance complies with the following standard: ISO 9906-A Rotodynamic pumps – hydraulic performance acceptance tests.

CHARACTERISTICS OF THE ELECTRIC PUMPS

The SH series comprises single-stage centrifugal pumps in pressed AISI 316 stainless steel. The hydraulic sizes and the diameters of the suction and delivery ports comply with EN 733 (ex DIN 24255).

Flange sizes comply with EN 1092-1. Available sizes: DN 25 to DN 80.

Motor: enbloc motor/pump coupling with bracket with impeller directly splined onto the motor shaft protrusion (SHE) or with joint, adaptor and rigid joint splined onto the shaft protrusion of normalised motors (SHS).



Technical data:

Flow rate: up to 240 m³/h (2 poles).
130 m³/h (4 poles).

Head: up to 110 m (2 poles).
23 m (4 poles).

Temperature of pumped liquid:
Standard from -10°C to +120°C.
Special versions available on request.
Maximum operating pressure: 12 bar (PN 12).

GS.../SH

Mechanical seal

Mechanical seal as per EN12756 (ex DIN 24960).

Anti-clockwise rotation looking at the pump from the suction port side.

Motor

Asynchronous three-phase, squirrel cage rotor, closed construction and externally ventilated.

Performance levels according to EN 60034-1. **Standard supplied IE2/IE3 motors are compliant with Regulation (EC) no. 640/2009 and IEC 60034-30.**

Protection class IP55.

Insulation class 155 (F).

Max. ambient temperature 40° C.

For different environmental conditions check the power rating.

Condensate drain plugs on all Lowara motors.

Standard voltage:

Single-phase 220-240 V, 50 Hz

Three-phase version: 220-240/380-415 V, 50 Hz for power ratings up to 3 kW;

380-415/660-690 V, 50 Hz for power ratings higher than 3 kW.

For electrical data of the motors used see Technical Appendix.

CHARACTERISTICS OF THE ELECTRIC PUMPS USED IN THE GS SERIES OF PRESSURE BOOSTER SETS

HORIZONTAL ELECTRIC PUMPS SERIES: SHE 32, 40, 50, 65, 80 SERIES

- Single impeller cast iron horizontal centrifugal with pump body and shaft made of AISI 316L stainless steel.
 - Closed impeller made of AISI 316L stainless steel laser technology welded (for sizes 25, 32, 40, 50, 65-160/75 and 65-160/110A) or AISI CF8M cast stainless steel.
 - Hydraulic sizes and nominal diameter DN of suction and discharge ports according to EN 733 (ex DIN 24255).
 - Flanges according to EN 1092-2 (ex UNI 2236) and DIN 2532.
 - Motor coupling: SHE, enbloc via joint with rotor directly splined onto the motor shaft protrusion. SHS, via joint, adaptor and rigid joint splined onto the protrusion of normalised motor shafts. **Standard supplied IE2/IE3 three-phase surface motors $\geq 0,75$ kW are compliant with Regulation (EC) no. 640/2009 and IEC 60034-30.**
- Performance levels according to EN 60034-1.
- **Booster sets drinking water use (DW version), pump has to have Ceramic, Carbon, EPDM seals.**

OPERATING CHARACTERISTICS AND LIMITS

Liquids handled	Water containing no gas or corrosive and/or aggressive substances.
Fluid temperature	Above -10°C a + 80 °C
Ambient temperature	Above 0°C a + 40 °C
Maximum operating pressure	Max 8 bar, 10 bar, 16 bar *
Minimum inlet pressure	According to NPSH curve and losses, with a minimum margin of 0.5 m
Maximum inlet pressure	The inlet pressure added to the pressure of the pump at zero flow must be lower than the maximum operating pressure of the set.
Installation	Indoors, protected from the weather. Away from heat sources. Max elevation 1000 m ASL. Max humidity 50% without condensation.
Hourly starts (single pump)	0,25 kW ≤ Pn ≤ 3 kW max 60 starts per hour. Direct motor start; 4 kW ≤ Pn ≤ 7,5 kW max 40 starts per hour. Direct motor start; 11 kW ≤ Pn ≤ kW max 30 starts per hour. Direct motor start; 18,5 kW ≤ Pn ≤ 22 kW max 24 starts per hour. Direct motor start; 30 kW ≤ Pn ≤ 37 kW max 16 starts per hour. Start/delta start; Pn = 45 kW max 8 starts per hour. Start/delta start;
Sound emission	See table

* On request, PN above in function of the service pump

gfixo_2p-en_c_ti

If there's jockey pump, PN can be lower

SOUND EMISSION LEVELS

50 Hz 2900 rpm		LpA (dB ±2)**	
P2 (kW)	IEC*	G..20	G..30
0,75	90R	<70	<70
1,1	90R	<70	<70
1,5	90	<70	<70
2,2	90	<70	<70
3	90	<70	70
4	112R	70	72
5,5	112	71	73
7,5	132	74	76
9,2	132	76	78
11	132	76	78
15	160	74	76
18,5	160	76	78
22	180R	73	75
30	200	75	77
37	200	75	77
45	225	78	80
55	250	78	80

* R=Reduced motor casing size with respect to shaft extension and related flange.

gsfixo_2p-en_b_tr

** Noise value of the electric motor only.

MAIN COMPONENTS

- **Main on-off valves** fitted to the suction and delivery lines of each pump, ball type with threaded connectors up to series SH 50, butterfly type for SH 65 and SH 80 pumps.
- **Check valve** on the delivery side of each pump, spring type with threaded connected up to 2", double-swing type between flanges over 2". For applications with air-cushion autoclaves, the check valves are mounted on the suction side and the unit is fitted with a G 1/2" threaded hose connector for the air supply (GS...RA series).
- **Suction manifold** in AISI 304 stainless steel, threaded or flanged depending on the type of pump (see drawings). Threaded water inlet connector.
- **Delivery manifold** in AISI 304 stainless steel, threaded or flanged depending on the type of pump (see drawings). Threaded R1" connectors with relative caps for connecting expansion vessels.
- **Pressure gauge** and **two control transmitters** located on the delivery side of the unit.
- **Various fittings** in nickel-plated brass, galvanised steel or stainless steel depending on the version.
- **Support base** for pump unit and board bracket in painted steel.
- **Control panel** protected to IP55.

AVAILABLE STANDARD VERSIONS

See material table.

STANDARD VERSION

For general use

Ball valves in nickel-plated brass, butterfly valves in polyamide, check valves in brass or painted cast-iron with flaps in steel, plugs, splines and flanges galvanised steel; manifolds in A304.

DW VERSION (GS../DW)

For use with drinking water

The main components in contact with the fluid are certified for drinking water or made from AISI 304 or superior stainless steel.

Valves in nickel-plated brass, butterfly valves in epoxy, check valves with flaps in AISI 304 steel; manifolds in A304.

AISI 304 VERSION (GS../A304), AISI 316 (GS../A316)

For special uses

The manifolds, valves, check valves and the main elements with parts in direct contact with the fluid are made of AISI 304 or AISI 316 stainless steel.

Optional accessories:

- **Dry-running prevention** devices in one of the following versions:
 - float switch, for negative heads;
 - pack of probe electrodes, for positive heads.
- **Autoclaves** in the following versions:
 - Air-cushion autoclaves with compressor and accessories for autoclave and compressor.
 - Diaphragm autoclaves instead of air-cushion versions.
- **Diaphragm expansion vessel** with ball valve (one for each pump) in the following versions, depending on the maximum head of the pumps:
 - Hydro tube kit 24 L 8 bar
 - Hydro tube kit 24 L 10 bar
 - Hydro tube kit 24 L 16 bar
- **Alarms kit;**
- **Air suction** for RA version;
- **Air compressor** for RA version;

SPECIAL VERSIONS AVAILABLE ON REQUEST

(Contact the Sales and technical Assistance Service)

- Units with non-standard input voltages, such as three-phase 3x230V, 3x440V.
- Units with single-phase input voltages 1x230V.
- Jockey pump other than the standard ones illustrated in the catalogue.
- Support base in AISI 304, AISI 316 stainless steel.
- Units with stainless steel expansion vessels.
- Units with special valves.
- Units with 4 electric pumps (GS40...).
- Units with 5 electric pumps (GS41... GS50...).
- Units with 6 electric pumps (GS51... GS60...).

TABLE OF MATERIALS FOR SETS WITH SH 25-32-40-50 PUMPS

NAME	MATERIAL			
	(STANDARD)	DW	A304	A316
Manifolds	AISI 304	AISI 304	AISI 304	AISI 316
On-off valves	Nickel-plated brass	Nickel-plated brass for drinking water	AISI 304	AISI 316
Non-return valves	AISI 304	AISI 304	AISI 304	AISI 316
Pressure switches	Chrome plated zinc alloy	AISI 304	AISI 304	AISI 304
Pressure transmitters	AISI 316	AISI 316	AISI 316	AISI 316
Nipples/caps/plugs/flanges	Galvanized steel	AISI 316	AISI 316	AISI 316
Bracket	Painted steel	Painted steel	Painted steel	Painted steel
Base	Painted steel	Painted steel	Painted steel	Painted steel
Electric pump body	AISI 316	AISI 316	AISI 316	AISI 316

gfixosh_2p-en_a_tm

TABLE OF MATERIALS FOR SETS WITH SHE/SHS 65-80 PUMPS

NAME	MATERIAL			
	(STANDARD)	DW	A304	A316
Manifolds	AISI 304	AISI 304	AISI 304	AISI 316
On-off valves	Polyamide	Polyamide	AISI 304	AISI 316
Non-return valves	Painted cast-iron with stainless steel flaps	Painted cast-iron with stainless steel flaps	AISI 304	AISI 316
Pressure switches	Chrome plated zinc alloy	AISI 304	AISI 304	AISI 304
Pressure transmitters	AISI 316	AISI 316	AISI 316	AISI 316
Nipples/caps/plugs/flanges	Galvanized steel	AISI 316	AISI 316	AISI 316
Bracket	Painted steel	Painted steel	Painted steel	Painted steel
Base	Painted steel	Painted steel	Painted steel	Painted steel
Electric pump body	AISI 316	AISI 316	AISI 316	AISI 316

gfixosh65-80_2p-en_a_tm

GS.../SH SERIES BOOSTER SETS HYDRAULIC PERFORMANCE TABLE AT 50 HZ (JOCKEY PUMP)

PUMP TYPE	NOMINAL POWER		Q = DELIVERY											
			l/min	0	12	20	25	30	35	40	45	50	60	73
	kW	HP	m ³ /h	0	0,7	1,2	1,5	1,8	2,1	2,4	2,7	3,0	3,6	4,4
H = TOTAL HEAD METRES COLUMN OF WATER														
3SV02	0,37	0,5	15			14,5	14,3	14,0	13,5	13,0	12,4	11,7	9,8	6,5
3SV03	0,37	0,5	22			21,2	20,8	20,3	19,6	18,7	17,7	16,6	13,7	8,6
3SV04	0,37	0,5	29			27,7	27,1	26,2	25,2	23,9	22,5	20,8	16,8	10,1
3SV05	0,55	0,75	37			36,4	35,8	35,0	33,9	32,6	31,1	29,2	24,5	16,2
3SV06	0,55	0,75	44			43,4	42,6	41,6	40,2	38,6	36,6	34,3	28,5	18,5
3SV07	0,75	1	53			51,8	51,0	50,0	48,7	47,0	45,0	42,5	36,1	24,6
3SV08	0,75	1	60			59,1	58,2	57,0	55,4	53,4	51,0	48,1	40,7	27,5
3SV09	1,1	1,5	68			66,8	65,8	64,5	62,8	60,6	57,9	54,6	46,4	31,6
3SV10	1,1	1,5	75			73,8	72,7	71,3	69,3	66,9	63,8	60,2	51,0	34,5
3SV11	1,1	1,5	82			81,0	79,7	78,0	75,8	73,1	69,7	65,7	55,5	37,4
3SV12	1,1	1,5	90			87,8	86,4	84,5	82,1	79,1	75,5	71,1	59,9	40,1
3SV13	1,5	2	98			96,7	95,4	93,5	91,0	87,8	83,9	79,2	67,2	45,6
3SV14	1,5	2	106			104,1	102,5	100,4	97,7	94,2	89,9	84,8	71,8	48,5
3SV16	1,5	2	120			117,8	116,1	113,6	110,5	106,5	101,6	95,8	80,9	54,2
3SV19	2,2	3	144			142,3	140,3	137,5	133,9	129,2	123,5	116,7	99,1	67,6
3SV21	2,2	3	159			157	155	151	147	142	136	128	108	74

gfix_fhe_pp_3sv-2p50-en_b_th

PUMP TYPE	NOMINAL POWER		Q = DELIVERY											
			l/min	0	30	40	50	60	70	80	100	120	150	
	kW	HP	m ³ /h	0	1,8	2,4	3	3,6	4,2	4,8	6	7,2	9	
H = TOTAL HEAD METRES COLUMN OF WATER														
CA 70/33	0,75	1	42,9	38,8	36,9	34,6	31,7	28,2	23,9					
CA 70/34	0,9	1,2	48,8	45,1	43,2	40,7	37,7	34,0	29,5					
CA 70/45	1,1	1,5	56,2	52,0	49,8	47,1	43,9	39,9	35,3					
CA 120/55	2,2	3	63,8			59,6	58,2	56,6	54,8	50,6	45,7	37,1		

Performance according to ISO 9906 - Annex A.

9490_pp_ca-2p50-en_a_th

GS20/SH, GS21/SH SERIES BOOSTER SETS HYDRAULIC PERFORMANCE TABLE AT 50 HZ (SERVICE PUMP)

SET TYPE GS20/..	NOMINAL POWER kW	Q = DELIVERY																			
		l/min 0	300	400	500	600	800	900	1200	1400	1600	1800	2000	2400	3000	3600	4000	5000	6300	7400	
		m ³ /h 0	18	24	30	36	48	54	72	84	96	108	120	144	180	216	240	300	378	444	
H = TOTAL HEAD METRES COLUMN OF WATER																					
SHE25-200/40	2 x 4	54,5	49,4	46,8	43,8	40,3	31,9	27													
SHE25-250/55	2 x 5,5	61,4	55,8	53,2	50,3	47	39,2														
SHE25-250/75	2 x 7,5	75,9	69,3	66,5	63,2	59,6	51,1														
SHE25-250/110	2 x 11	87,5	81,5	78,7	75,4	71,8	63,3	58,4													
SHE32-125/7,5	2 x 0,75	16,6	14,4	13,0	11,3	9,5															
SHE32-125/11	2 x 1,1	21,6	19,4	17,8	16,2	14,2	9,8														
SHE32-160/15	2 x 1,5	27,6	24,6	22,7	20,6	18,1	12,7														
SHE32-160/22	2 x 2,2	35,0	32,5	31,0	29,0	26,6	21,0	18,0													
SHE32-200/30	2 x 3	43,7	38,5	36,0	33,0	30,0	22,3														
SHE32-200/40	2 x 4	53,5	49,0	46,8	44,0	41,0	33,8	28,8													
SHE32-250/55	2 x 5,5	61,7	56,7	54,2	51,2	47,9	40,0														
SHE32-250/75	2 x 7,5	74,1	68,9	66,2	63,0	60,0	52,2														
SHE32-250/110	2 x 11	86,2	80,1	77,5	74,3	71,0	63,3	59													
SHE40-125/11	2 x 1,1	14,4				12,5	10,9	10,0	7,0												
SHE40-125/15	2 x 1,5	17,5				16,0	14,4	13	10,2	8,0											
SHE40-125/22	2 x 2,2	25,3				22,2	20,4	19,5	15,9	13,2											
SHE40-160/30	2 x 3	32,2				29,5	26,9	25	20,8	17,0											
SHE40-160/40	2 x 4	38,0				35,5	33,2	31,7	26,7	22,8	18,5										
SHE40-200/55	2 x 5,5	49,1				46,4	43,8	42	36,2	31,0	25,0										
SHE40-200/75	2 x 7,5	58,2				55,1	52,3	50,8	45,0	40,0	34,5										
SHE40-250/92	2 x 9,2	64,9				62,0	59,5	58	51,5	44,6											
SHE40-250/110	2 x 11	74,7				71,4	69,0	67,8	61,5	55,2											
SHE40-250/150	2 x 15	87,7				84,2	81,5	80	74,3	69,2	62,5										
SHE50-125/22	2 x 2,2	17,2							14,6	13,4	12,2	11,0	9,5	6,5							
SHE50-125/30	2 x 3	21,7							18,8	17,5	16,3	14,8	13,4	10,5							
SHE50-125/40	2 x 4	25,7							23,3	22,2	20,8	19,3	18,0	15,0							
SHE50-160/55	2 x 5,5	34,1							30,6	29,2	27,6	28,0	26,6	19,8							
SHE50-160/75	2 x 7,5	40,8							37,5	36,2	34,8	25,8	24,0	27,0	18,6						
SHE50-200/92	2 x 9,2	53,0							47,5	45,3	42,8	40,0	36,8	29,8							
SHE50-200/110	2 x 11	60,1							55,0	52,8	50,3	47,5	44,3	37,5							
SHE50-250/150	2 x 15	70,2							66,6	65,0	63,3	61,0	58,3	51,0							
SHE50-250/185	2 x 18,5	80,0							75,0	73,2	71,4	69,0	66,3	59,5							
SHE50-250/220	2 x 22	88,9							84,6	82,8	80,7	78,5	75,8	69,5							
SHE65-160/40	2 x 4	19,6									16,8	16,0	15,2	13,5	10,8	7,6					
SHE65-160/55	2 x 5,5	24,2									21,4	20,7	19,8	18,0	15,2	11,8					
SHE65-160/75	2 x 7,5	28,2									26,0	25,3	24,7	23,0	20,0	16,8	14,5				
SHE65-160/92	2 x 9,2	38,2									35,4	34,3	33,0	30,0	25,5	20,0					
SHE65-160/110	2 x 11	43,2									40,8	39,8	38,5	35,5	30,6	25,4	21,4				
SHE65-200/150	2 x 15	53,0										48,8	47,5	44,3	38,5	32,0					
SHE65-200/185	2 x 18,5	60,2										56,5	55,3	52,0	47,0	40,0	35,4				
SHE65-200/220	2 x 22	68,0										64,4	63,3	60,0	55,0	49,0	44,5				
SHS65-250/300	2 x 30	84,3											81,7	79,5	75,0	69,0	64,0				
SHS65-250/370	2 x 37	98,0												95,3	93,0	88,0	82,5	78,0			
SHE80-160/110	2 x 11	33,6												31,9	30,0	27,5	25,5	20,5	12,5		
SHE80-160/150	2 x 15	40,3													38,8	37,0	34,5	33,0	27,5	20,0	
SHE80-160/185	2 x 18,5	47,2													45,7	44,0	41,5	40,0	35,0	27,5	19,5
SHE80-200/220	2 x 22	53,0														49,8	47,5	46,0	41,0	33,5	
SHS80-200/300	2 x 30	63,6														61,2	59,0	57,0	52,0	44,0	36,5
SHS80-200/370	2 x 37	71,4														69,5	67,5	66,0	61,0	53,5	46,0

The table refers to performance with 2 pumps running.

gms_2psh_2p50-en_a_th

GS30/SH SERIES BOOSTER SETS HYDRAULIC PERFORMANCE TABLE AT 50 HZ (SERVICE PUMP)

SET TYPE GS30/..	NOMINAL POWER kW	Q = DELIVERY																						
		<i>v</i> min 0	450	600	750	900	1200	1350	1800	2100	2400	2700	3000	3600	4500	5400	6000	7500	9450	11100				
		m ³ /h 0	27	36	45	54	72	81	108	126	144	162	180	216	270	324	360	450	567	666				
H = TOTAL HEAD METRES COLUMN OF WATER																								
SHE25-200	3 x 4	54,5	49,4	46,8	43,8	40,3	31,9	27																
SHE25-250	3 x 5,5	61,4	55,8	53,2	50,3	47	39,2																	
SHE25-250	3 x 7,5	75,9	69,3	66,5	63,2	59,6	51,1																	
SHE25-250	3 x 11	87,5	81,5	78,7	75,4	71,8	63,3	58,4																
SHE32-125	3 x 0,75	16,6	14,4	13,0	11,3	9,5																		
SHE32-125	3 x 1,1	21,6	19,4	17,8	16,2	14,2	9,8																	
SHE32-160	3 x 1,5	27,6	24,6	22,7	20,6	18,1	12,7																	
SHE32-160	3 x 2,2	35,0	32,5	31,0	29,0	26,6	21,0	18,0																
SHE32-200	3 x 3	43,7	38,5	36,0	33,0	30,0	22,3																	
SHE32-200	3 x 4	53,5	49,0	46,8	44,0	41,0	33,8	28,8																
SHE32-250	3 x 5,5	61,7	56,7	54,2	51,2	47,9	40,0																	
SHE32-250	3 x 7,5	74,1	68,9	66,2	63,0	60,0	52,2																	
SHE32-250	3 x 11	86,2	80,1	77,5	74,3	71,0	63,3	59																
SHE40-125	3 x 1,1	14,4				12,5	10,9	10,0	7,0															
SHE40-125	3 x 1,5	17,5				16,0	14,4	13	10,2	8,0														
SHE40-125	3 x 2,2	25,3				22,2	20,4	19,5	15,9	13,2														
SHE40-160	3 x 3	32,2				29,5	26,9	25	20,8	17,0														
SHE40-160	3 x 4	38,0				35,5	33,2	31,7	26,7	22,8	18,5													
SHE40-200	3 x 5,5	49,1				46,4	43,8	42	36,2	31,0	25,0													
SHE40-200	3 x 7,5	58,2				55,1	52,3	50,8	45,0	40,0	34,5													
SHE40-250	3 x 9,2	64,9				62,0	59,5	58	51,5	44,6														
SHE40-250	3 x 11	74,7				71,4	69,0	67,8	61,5	55,2														
SHE40-250	3 x 15	87,7				84,2	81,5	80	74,3	69,2	62,5													
SHE50-125	3 x 2,2	17,2							14,6	13,4	12,2	11,0	9,5	6,5										
SHE50-125	3 x 3	21,7							18,8	17,5	16,3	14,8	13,4	10,5										
SHE50-125	3 x 4	25,7							23,3	22,2	20,8	19,3	18,0	15,0										
SHE50-160	3 x 5,5	34,1							30,6	29,2	27,6	28,0	26,6	19,8										
SHE50-160	3 x 7,5	40,8							37,5	36,2	34,8	25,8	24,0	27,0	18,6									
SHE50-200	3 x 9,2	53,0							47,5	45,3	42,8	40,0	36,8	29,8										
SHE50-200	3 x 11	60,1							55,0	52,8	50,3	47,5	44,3	37,5										
SHE50-250	3 x 15	70,2							66,6	65,0	63,3	61,0	58,3	51,0										
SHE50-250	3 x 18,5	80,0							75,0	73,2	71,4	69,0	66,3	59,5										
SHE50-250	3 x 22	88,9							84,6	82,8	80,7	78,5	75,8	69,5										
SHE65-160	3 x 4	19,6									16,8	16,0	15,2	13,5	10,8	7,6								
SHE65-160	3 x 5,5	24,2									21,4	20,7	19,8	18,0	15,2	11,8								
SHE65-160	3 x 7,5	28,2									26,0	25,3	24,7	23,0	20,0	16,8	14,5							
SHE65-160	3 x 9,2	38,2									35,4	34,3	33,0	30,0	25,5	20,0								
SHE65-160	3 x 11	43,2									40,8	39,8	38,5	35,5	30,6	25,4	21,4							
SHE65-200	3 x 15	53,0										48,8	47,5	44,3	38,5	32,0								
SHE65-200	3 x 18,5	60,2										56,5	55,3	52,0	47,0	40,0	35,4							
SHE65-200	3 x 22	68,0										64,4	63,3	60,0	55,0	49,0	44,5							
SHS65-250	3 x 30	84,3											81,7	79,5	75,0	69,0	64,0							
SHS65-250	3 x 37	98,0												95,3	93,0	88,0	82,5	78,0						
SHE80-160	3 x 11	33,6												31,9	30,0	27,5	25,5	20,5	12,5					
SHE80-160	3 x 15	40,3													38,8	37,0	34,5	33,0	27,5	20,0				
SHE80-160	3 x 18,5	47,2														45,7	44,0	41,5	40,0	35,0	27,5	19,5		
SHE80-200	3 x 22	53,0															49,8	47,5	46,0	41,0	33,5			
SHS80-200	3 x 30	63,6																61,2	59,0	57,0	52,0	44,0	36,5	
SHS80-200	3 x 37	71,4																	69,5	67,5	66,0	61,0	53,5	46,0

The table refers to performance with 3 pumps running.

gms_3psh_2p50-en_a_th

GS.../SH

**GS20, GS21, GS30/SH SERIES BOOSTER SETS
ELECTRICAL DATA TABLE AT 50 Hz**

SERVICE PUMP 3 X 400 V			JOCKEY PUMP 3 X 400 V			CURRENT ABSORBED BY SET 3 X 400V		
TYPE	Pn kW	In A	TYPE	Pn kW	In A	GS20 A	GS21 A	GS30 A
SHE25-200/40	4	7,63	CA70/45	1,1	2,83	15,26	18,09	22,89
SHE25-250/55	5,5	10,4	CA120/55	1,85	4,65	20,80	25,45	31,20
SHE25-250/75	7,5	14	3SV11	1,1	2,39	28,00	30,39	42,00
SHE25-250/110	11	20,3	3SV12	1,1	2,39	40,60	42,99	60,90
SHE32-125/07	0,75	1,7	CA70/33	0,75	1,87	3,40	5,27	5,10
SHE32-125/11	1,1	2,39	CA70/33	0,75	1,87	4,78	6,65	7,17
SHE32-160/15	1,5	3,17	CA70/33	0,75	1,87	6,34	8,21	9,51
SHE32-160/22	2,2	4,64	CA70/33	0,75	1,87	9,28	11,15	13,92
SHE32-200/30	3	6,14	CA70/34	0,9	2,37	12,28	14,65	18,42
SHE32-200/40	4	7,63	CA70/45	1,1	2,83	15,26	18,09	22,89
SHE32-250/55	5,5	10,4	CA120/55	1,85	4,65	20,80	25,45	31,20
SHE32-250/75	7,5	14	3SV10	1,1	2,39	28,00	30,39	42,00
SHE32-250/110	11	20,3	3SV12	1,1	2,39	40,60	42,99	60,90
SHE40-125/11	1,1	2,39	CA70/33	0,75	1,87	4,78	6,65	7,17
SHE40-125/15	1,5	3,17	CA70/33	0,75	1,87	6,34	8,21	9,51
SHE40-125/22	2,2	4,64	CA70/33	0,75	1,87	9,28	11,15	13,92
SHE40-160/30	3	6,14	CA70/33	0,75	1,87	12,28	14,15	18,42
SHE40-160/40	4	7,63	CA70/33	0,75	1,87	15,26	17,13	22,89
SHE40-200/55	5,5	10,4	CA70/34	0,9	2,37	20,80	23,17	31,20
SHE40-200/75	7,5	14	CA120/55	1,85	4,65	28,00	32,65	42,00
SHE40-250/92	9,2	16,8	3SV09	1,1	2,39	33,60	35,99	50,40
SHE40-250/110	11	20,3	3SV11	1,1	2,39	40,60	42,99	60,90
SHE40-250/150	15	26	3SV12	1,1	2,39	52,00	54,39	78,00
SHE50-125/22	2,2	4,64	CA70/33	0,75	1,87	9,28	11,15	13,92
SHE50-125/30	3	6,14	CA70/33	0,75	1,87	12,28	14,15	18,42
SHE50-125/40	4	7,63	CA70/33	0,75	1,87	15,26	17,13	22,89
SHE50-160/55	5,5	10,4	CA70/33	0,75	1,87	20,80	22,67	31,20
SHE50-160/75	7,5	14	CA70/33	0,75	1,87	28,00	29,87	42,00
SHE50-200/92	9,2	16,8	CA70/45	1,1	2,83	33,60	36,43	50,40
SHE50-200/110	11	20,3	CA120/55	1,85	4,65	40,60	45,25	60,90
SHE50-250/150	15	26	3SV10	1,1	2,39	52,00	54,39	78,00
SHE50-250/185	18,5	33,2	3SV11	1,1	2,39	66,40	68,79	99,60
SHE50-250/220	22	38,6	3SV12	1,1	2,39	77,20	79,59	115,80
SHE65-160/40	4	7,63	CA70/33	0,75	1,87	15,26	17,13	22,89
SHE65-160/55	5,5	10,4	CA70/33	0,75	1,87	20,80	22,67	31,20
SHE65-160/75	7,5	14	CA70/33	0,75	1,87	28,00	29,87	42,00
SHE65-160/92	9,2	16,8	CA70/33	0,75	1,87	33,60	35,47	50,40
SHE65-160/110	11	20,3	CA70/33	0,75	1,87	40,60	42,47	60,90
SHE65-200/150	15	26	CA70/45	1,1	2,83	52,00	54,83	78,00
SHE65-200/185	18,5	33,2	CA120/55	1,85	4,65	66,40	71,05	99,60
SHE65-200/220	22	38,6	3SV10	1,1	2,39	77,20	79,59	115,80
SHS65-250/300	30	53,6	3SV12	1,1	2,39	107,20	109,59	160,80
SHS65-250/370	37	65,8	3SV13	1,5	3,17	131,60	134,77	197,40
SHE80-160/110	11	20,3	CA70/33	0,75	1,87	40,60	42,47	60,90
SHE80-160/150	15	26	CA70/33	0,75	1,87	52,00	53,87	78,00
SHE80-160/185	18,5	33,2	CA70/34	0,9	2,37	66,40	68,77	99,60
SHE80-200/220	22	38,6	CA70/45	1,1	2,83	77,20	80,03	115,80
SHS80-200/300	30	53,6	CA120/55	1,85	4,65	107,20	111,85	160,80
SHS80-200/370	37	65,8	3SV10	1,1	2,39	131,60	133,99	197,40

The current shown is the nominal current of the set.

gms_shes_2p50_d_te

Booster sets

MARKET SECTORS

CIVIL, INDUSTRIAL

APPLICATIONS

- Water network supply in condominiums, offices, hotels, shopping centres, factories.
- Water supply to agricultural water networks (e.g. irrigation).

GSD20 - GSY20 Series

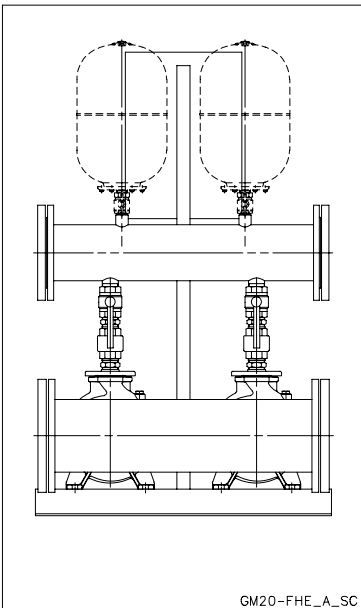

SPECIFICATIONS

- **Flow rate** up to 444 m³/h.
- **Head** up to 100 m.
- Electrical panel supply voltage: 3 x 400V ± 10%.
- Frequency 50 Hz.
- Voltage for controls outside panel: 24 Vac.
- Electrical panel protection class IP 55.
- Maximum service pump power: 2 x 37 kW.
- **Motor start-up:**
 - Direct for powers up to 22 kW inclusive for pump (GSD/).
 - Star/Delta for higher powers (GSY/ set).
 - Softstarter, available on request (GSR../ set).
- **Electric pumps with horizontal axis:**
 - SH series (motor protection class IP55).
- Maximum operating pressure: 16 bar.
- Maximum temperature of pumped liquid : +80°C.

**TWO-PUMP BOOSTER SETS, GSD20-GSY20 SERIES
HORIZONTAL ELECTRIC PUMPS WITH NON-RETURN VALVE
ON DISCHARGE SIDE**

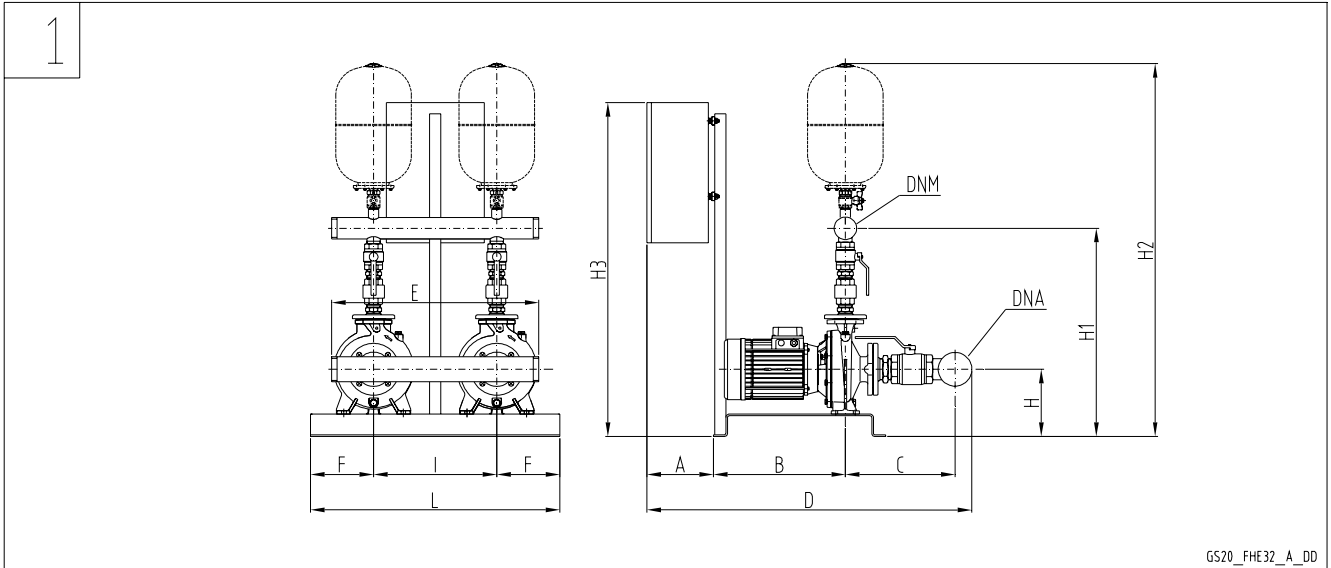

GS.../SH

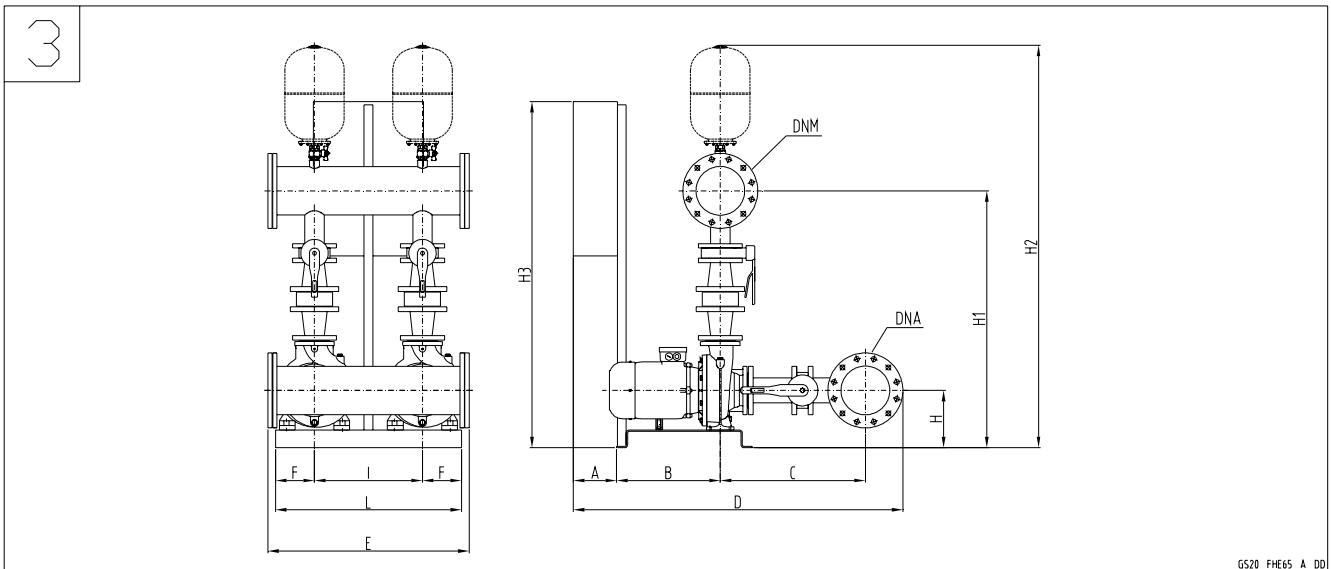
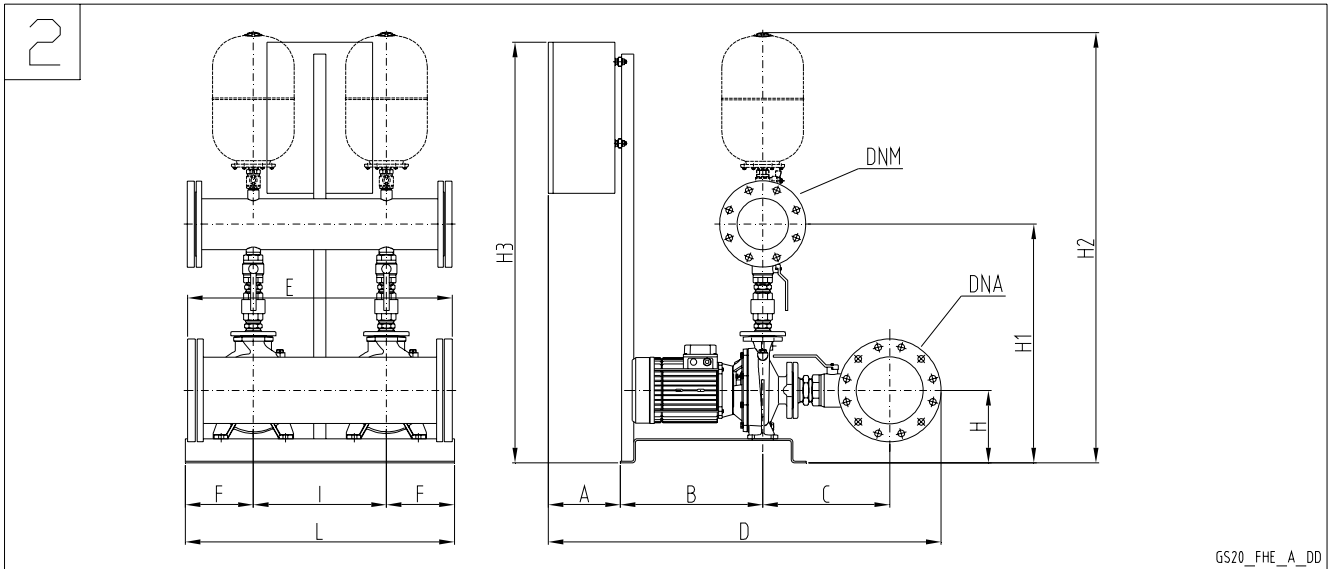

TWO-PUMP BOOSTER SETS, GSD20-GSY20 SERIES HORIZONTAL ELECTRIC PUMPS WITH NON-RETURN VALVE ON DISCHARGE SIDE

GSD20 / GSY20	DRW N°	DNA	DNM	A	B	C	D	E	F	H	H1	H2	H3	I	L
SHE25-200/40	1	80	65	192	302	290	828	722	135	240	638	1226	1016	370	640
SHE25.250/55	1	80	65	192	302	310	848	722	135	260	703	1291	973	370	640
SHE25-250/75	1	80	65	192	302	310	848	722	135	260	703	1291	973	370	640
SHE25-250/110	1	80	65	192	302	310	848	722	135	260	703	1291	973	370	640
SHE32-125/07	1	80	65	192	302	305	843	722	135	192	601	1189	1016	370	640
SHE32-125/11	1	80	65	192	302	305	843	722	135	192	601	1189	1016	370	640
SHE32-160/15	1	80	65	192	302	305	843	722	135	212	641	1229	1016	370	640
SHE32-160/22	1	80	65	192	302	305	843	722	135	212	641	1229	1016	370	640
SHE32-200/30	1	80	65	192	302	305	843	722	135	240	689	1277	1016	370	640
SHE32-200/40	1	80	65	192	302	305	843	722	135	240	689	1277	1016	370	640
SHE32-250/55	1	80	65	192	300	325	861	722	135	260	754	1342	973	370	640
SHE32-250/75	1	80	65	192	300	325	861	722	135	260	754	1342	973	370	640
SHE32-250/110	1	80	65	192	300	325	861	722	135	260	754	1342	973	370	640
SHE40-125/11	2	100	100	196	471	332	1109	842	200	192	659	1266	1017	490	890
SHE40-125/15	2	100	100	194	471	332	1107	842	200	192	659	1266	1017	490	890
SHE40-125/22	2	100	100	194	471	332	1107	842	200	192	659	1266	1017	490	890
SHE40-160/30	2	100	100	194	471	332	1107	842	200	212	699	1306	1017	490	890
SHE40-160/40	2	100	100	194	471	332	1107	842	200	212	699	1306	1017	490	890
SHE40-200/55	2	100	100	194	471	352	1127	842	200	240	747	1354	974	490	890
SHE40-200/75	2	100	100	194	471	352	1127	842	200	240	747	1354	974	490	890
SHE40-250/92	2	100	100	194	471	352	1127	842	200	260	812	1419	974	490	890
SHE40-250/110	2	100	100	194	471	352	1127	842	200	260	812	1419	974	490	890
SHE40-250/150	2	100	100	244	568	352	1274	842	200	260	812	1419	1121	490	890
SHE50-125/22	2	150	125	196	471	379	1189	842	200	212	737	1357	1017	490	890
SHE50-125/30	2	150	125	196	471	379	1189	842	200	212	737	1357	1017	490	890
SHE50-125/40	2	150	125	196	471	379	1189	842	200	212	737	1357	1017	490	890
SHE50-160/55	2	150	125	196	471	379	1189	842	200	240	785	1405	974	490	890
SHE50-160/75	2	150	125	196	471	379	1189	842	200	240	785	1405	974	490	890
SHE50-200/92	2	150	125	196	471	379	1189	842	200	240	805	1425	974	490	890
SHE50-200/110	2	150	125	196	471	379	1189	842	200	240	805	1425	974	490	890
SHE50-250/150	2	150	125	246	568	379	1336	842	200	260	850	1470	1121	490	890
SHE50-250/185	2	150	125	235	815	379	1572	842	365	300	890	1510	1121	490	1220
SHE50-250/220	2	150	125	285	815	379	1622	842	365	300	890	1510	1571	490	1220
SHE65-160/40	3	200	150	196	471	589	1426	842	200	240	1054	1688	1017	490	890
SHE65-160/55	3	200	150	196	471	589	1426	842	200	240	1054	1688	974	490	890
SHE65-160/75	3	200	150	196	471	589	1426	842	200	240	1054	1688	974	490	890
SHE65-160/92	3	200	150	196	471	589	1426	842	200	240	1054	1688	974	490	890
SHE65-160/110	3	200	150	196	471	589	1426	842	200	240	1054	1688	974	490	890
SHE65-200/150	3	200	150	246	568	589	1573	842	200	260	1099	1733	1121	490	890
SHE65-200/185	3	200	150	235	815	589	1809	842	365	300	1139	1773	1121	490	1220
SHE65-200/220	3	200	150	285	815	589	1859	842	365	300	1139	1773	1571	490	1220
SHS65-250/300	3	200	150	285	915	589	1959	842	365	320	1184	1818	1571	490	1220
SHS65-250/370	3	200	150	285	915	589	1959	842	365	320	1184	1818	1571	490	1220
SHE80-160/110	3	250	200	196	471	687	1556	982	200	260	1166	1825	974	490	890
SHE80-160/150	3	250	200	246	568	687	1703	982	200	260	1166	1825	1121	490	890
SHE80-160/185	3	250	200	235	815	687	1939	982	365	300	1206	1865	1121	490	1220
SHE80-200/220	3	250	200	285	815	687	1989	982	365	300	1231	1890	1571	490	1220
SHS80-200/300	3	250	200	285	915	687	2089	982	365	320	1251	1910	1571	490	1220
SHS80-200/370	3	250	200	285	915	687	2089	982	365	320	1281	1940	1571	490	1220

Dimensions in mm. Tolerance ± 10 mm.

gs20_she-en_b_td

**TWO-PUMP BOOSTER SETS, GSD20-GSY20 RA SERIES
HORIZONTAL ELECTRIC PUMPS WITH NON-RETURN VALVE
ON SUCTION SIDE**

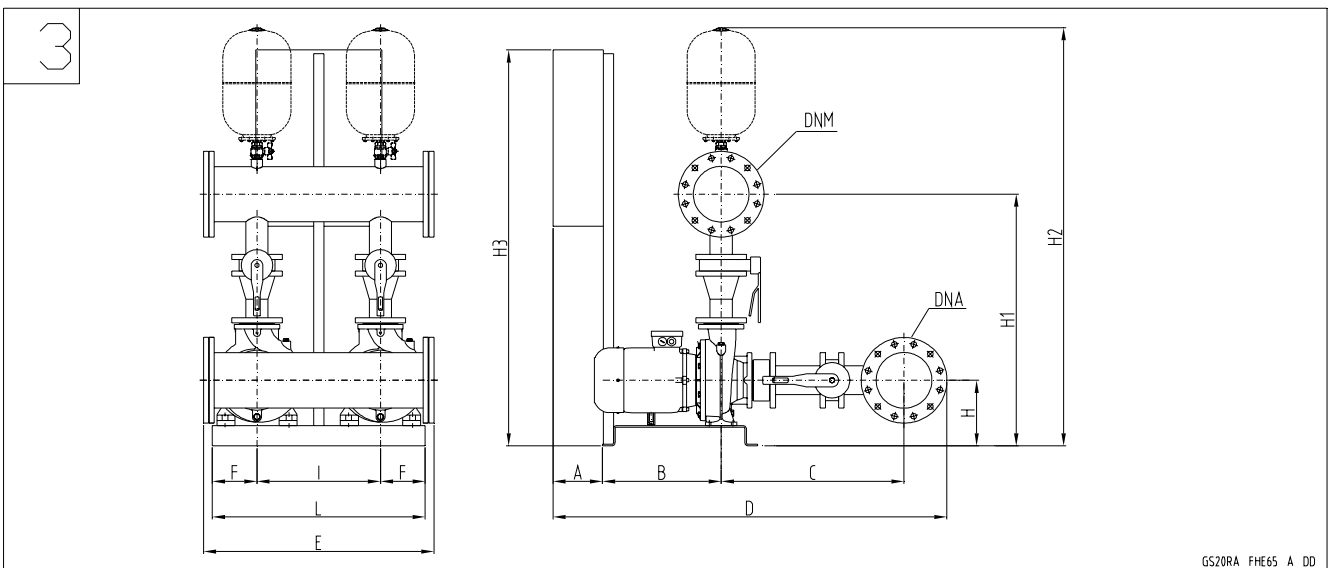
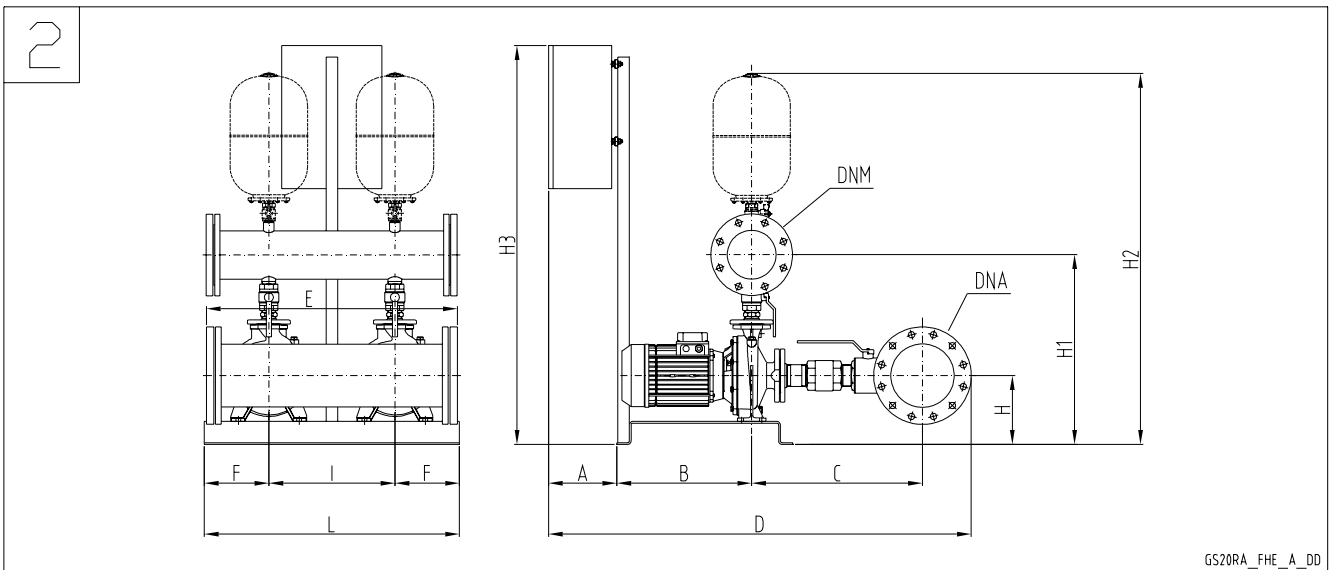
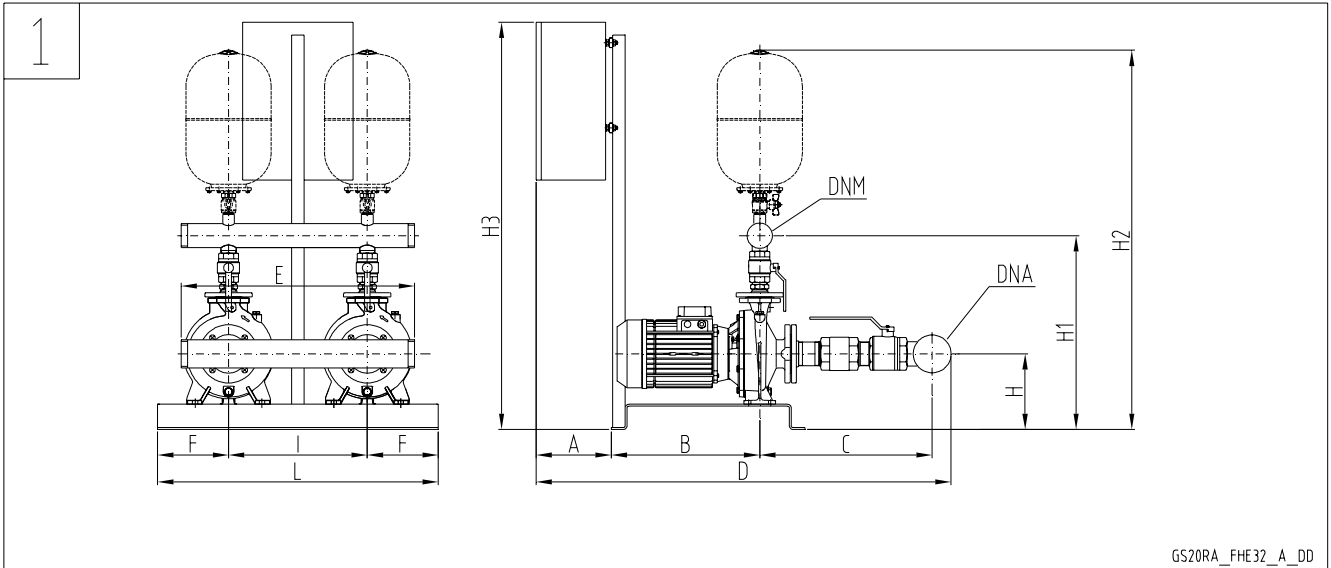

GS.../SH

TWO-PUMP BOOSTER SETS, GSD20-GSY20 RA SERIES HORIZONTAL ELECTRIC PUMPS WITH NON-RETURN VALVE ON SUCTION SIDE

GSD20 / GSY20RA	DRW N°	DNA	DNM	A	B	C	D	E	F	H	H1	H2	H3	I	L
SHE25-200/40	1	80	65	192	302	425	963	722	135	240	533	1121	1016	370	640
SHE25.250/55	1	80	65	192	302	445	983	722	135	260	598	1186	973	370	640
SHE25-250/75	1	80	65	192	302	445	983	722	135	260	598	1186	973	370	640
SHE25-250/110	1	80	65	192	302	445	983	722	135	260	598	1186	973	370	640
SHE32-125/07	1	80	65	192	302	425	963	722	135	192	496	1084	1016	370	640
SHE32-125/11	1	80	65	192	302	425	963	722	135	192	496	1084	1016	370	640
SHE32-160/15	1	80	65	192	302	425	963	722	135	212	536	1124	1016	370	640
SHE32-160/22	1	80	65	192	302	425	963	722	135	212	536	1124	1016	370	640
SHE32-200/30	1	80	65	192	302	425	963	722	135	240	584	1172	1016	370	640
SHE32-200/40	1	80	65	192	302	425	963	722	135	240	584	1172	1016	370	640
SHE32-250/55	1	80	65	192	300	445	981	722	135	260	649	1237	973	370	640
SHE32-250/75	1	80	65	192	300	445	981	722	135	260	649	1237	973	370	640
SHE32-250/110	1	80	65	192	300	445	981	722	135	260	649	1237	973	370	640
SHE40-125/11	2	100	100	196	471	514	1291	842	200	192	548	1155	1017	490	890
SHE40-125/15	2	100	100	194	471	514	1289	842	200	192	548	1155	1017	490	890
SHE40-125/22	2	100	100	194	471	514	1289	842	200	192	548	1155	1017	490	890
SHE40-160/30	2	100	100	194	471	514	1289	842	200	212	588	1195	1017	490	890
SHE40-160/40	2	100	100	194	471	514	1289	842	200	212	588	1195	1017	490	890
SHE40-200/55	2	100	100	194	471	534	1309	842	200	240	636	1243	974	490	890
SHE40-200/75	2	100	100	194	471	534	1309	842	200	240	636	1243	974	490	890
SHE40-250/92	2	100	100	194	471	534	1309	842	200	260	701	1308	974	490	890
SHE40-250/110	2	100	100	194	471	534	1309	842	200	260	701	1308	974	490	890
SHE40-250/150	2	100	100	244	568	534	1456	842	200	260	701	1308	1121	490	890
SHE50-125/22	2	150	125	196	471	561	1371	842	200	212	624	1244	1017	490	890
SHE50-125/30	2	150	125	196	471	561	1371	842	200	212	624	1244	1017	490	890
SHE50-125/40	2	150	125	196	471	561	1371	842	200	212	624	1244	1017	490	890
SHE50-160/55	2	150	125	196	471	561	1371	842	200	240	672	1292	974	490	890
SHE50-160/75	2	150	125	196	471	561	1371	842	200	240	672	1292	974	490	890
SHE50-200/92	2	150	125	196	471	561	1371	842	200	240	692	1312	974	490	890
SHE50-200/110	2	150	125	196	471	561	1371	842	200	240	692	1312	974	490	890
SHE50-250/150	2	150	125	246	568	561	1518	842	200	260	737	1357	1121	490	890
SHE50-250/185	2	150	125	235	815	561	1754	842	365	300	777	1397	1121	490	1220
SHE50-250/220	2	150	125	285	815	561	1804	842	365	300	777	1397	1571	490	1220
SHE65-160/40	3	200	150	196	471	649	1486	842	200	240	928	1562	1017	490	890
SHE65-160/55	3	200	150	196	471	649	1486	842	200	240	928	1562	974	490	890
SHE65-160/75	3	200	150	196	471	649	1486	842	200	240	928	1562	974	490	890
SHE65-160/92	3	200	150	196	471	649	1486	842	200	240	928	1562	974	490	890
SHE65-160/110	3	200	150	196	471	649	1486	842	200	240	928	1562	974	490	890
SHE65-200/150	3	200	150	246	568	649	1633	842	200	260	973	1607	1121	490	890
SHE65-200/185	3	200	150	235	815	649	1869	842	365	300	1013	1647	1121	490	1220
SHE65-200/220	3	200	150	285	815	649	1919	842	365	300	1013	1647	1571	490	1220
SHS65-250/300	3	200	150	285	915	649	2019	842	365	320	1058	1692	1571	490	1220
SHS65-250/370	3	200	150	285	915	649	2019	842	365	320	1058	1692	1571	490	1220
SHE80-160/110	3	250	200	196	471	754	1623	982	200	260	999	1658	974	490	890
SHE80-160/150	3	250	200	246	568	754	1770	982	200	260	999	1658	1121	490	890
SHE80-160/185	3	250	200	235	815	754	2006	982	365	300	1039	1698	1121	490	1220
SHE80-200/220	3	250	200	285	815	754	2056	982	365	300	1064	1723	1571	490	1220
SHS80-200/300	3	250	200	285	915	754	2156	982	365	320	1084	1743	1571	490	1220
SHS80-200/370	3	250	200	285	915	754	2156	982	365	320	1114	1773	1571	490	1220

Dimensions in mm. Tolerance ± 10 mm.

gs20ra_she-en_b_td

Booster sets

MARKET SECTORS
CIVIL, INDUSTRIAL

APPLICATIONS

- Water network supply in condominiums, offices, hotels, shopping centres, factories.
- Water supply to agricultural water networks (e.g. irrigation).

GSD21 - GSY21 Series

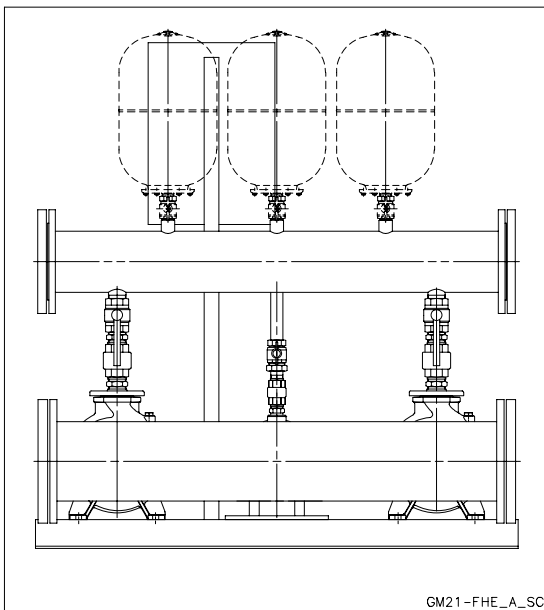

SPECIFICATIONS

- **Flow rate** up to 444 m³/h.
- **Head** up to 100 m.
- Electrical panel supply voltage: 3 x 400V ± 10%.
- Frequency 50 Hz.
- Voltage for controls outside panel: 24 Vac.
- Electrical panel protection class IP 55.
- Maximum service pump power: 2 x 37 kW.
- **Motor start-up:**
 - Direct for powers up to 22 kW inclusive for pump (GSD/).
 - Star/Delta for higher powers (GSY/ set).
 - Softstarter, available on request (GSR../ set).
- **Electric pumps with horizontal axis:**
 - SH series (motor protection class IP55).
- **Electric jockey pumps**
 - SV and CA series (motor protection class IP55).
- Maximum operating pressure: 16 bar.
- Maximum temperature of pumped liquid : +80C.

**TWO-PUMP BOOSTER SETS, GSD21 SERIES
HORIZONTAL ELECTRIC PUMPS WITH JOCKEY PUMP
NON-RETURN VALVE ON DISCHARGE SIDE**

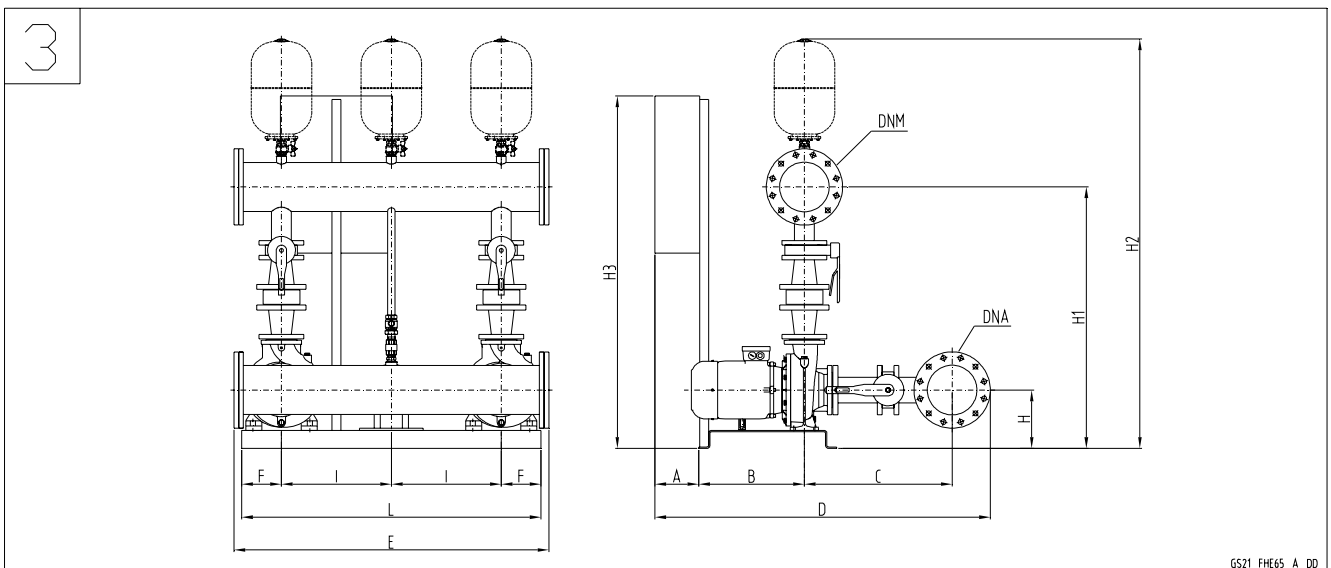
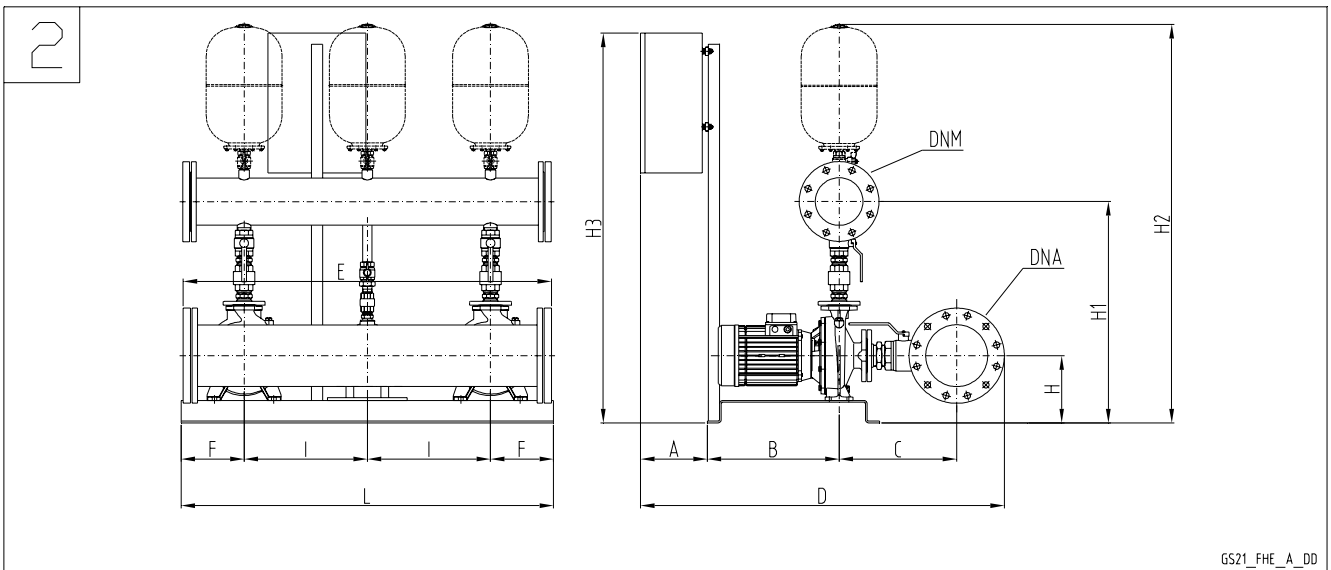
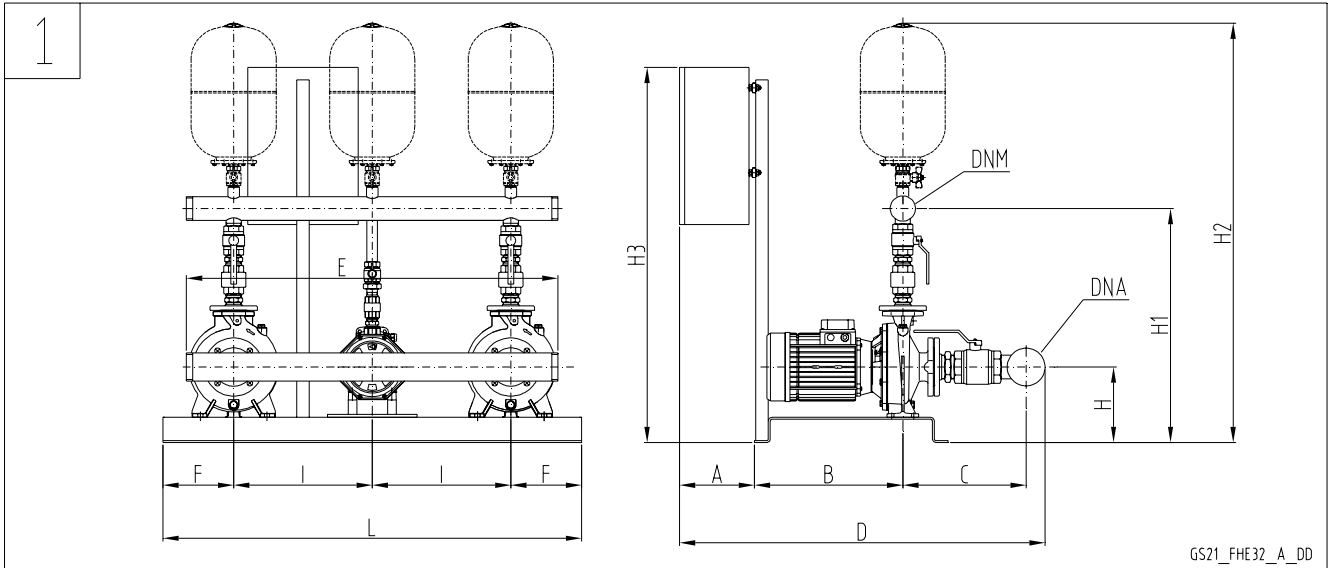

GS.../SH

**TWO-PUMP BOOSTER SETS, GSD21 SERIES
HORIZONTAL ELECTRIC PUMPS WITH JOCKEY PUMP
NON-RETURN VALVE ON DISCHARGE SIDE**

GSD21	DRW N°	DNA	DNM	A	B	C	D	E	F	H	H1	H2	H3	I	L
SHE25-200/40	1	80	65	242	302	290	878	1092	128	240	638	1226	973	370	995
SHE25-250/55	1	80	65	242	302	310	898	1092	128	260	703	1291	973	370	995
SHE25-250/75	1	80	65	242	302	310	898	1092	128	260	703	1291	973	370	995
SHE25-250/110	1	80	65	242	302	310	898	1092	128	260	703	1291	973	370	995
SHE32-125/07	1	80	65	242	302	305	893	1092	128	192	601	1189	973	370	995
SHE32-125/11	1	80	65	242	302	305	893	1092	128	192	601	1189	973	370	995
SHE32-160/15	1	80	65	242	302	305	893	1092	128	212	641	1229	973	370	995
SHE32-160/22	1	80	65	242	302	305	893	1092	128	212	641	1229	973	370	995
SHE32-200/30	1	80	65	242	302	305	893	1092	128	240	689	1277	973	370	995
SHE32-200/40	1	80	65	242	302	305	893	1092	128	240	689	1277	973	370	995
SHE32-250/55	1	80	65	242	300	325	911	1092	128	260	754	1342	973	370	995
SHE32-250/75	1	80	65	242	300	325	911	1092	128	260	754	1342	973	370	995
SHE32-250/110	1	80	65	242	300	325	911	1092	128	260	754	1342	973	370	995
SHE40-125/11	2	100	100	246	471	332	1159	1332	177	192	659	1266	974	490	1334
SHE40-125/15	2	100	100	244	471	332	1157	1332	177	192	659	1266	974	490	1334
SHE40-125/22	2	100	100	244	471	332	1157	1332	177	192	659	1266	974	490	1334
SHE40-160/30	2	100	100	244	471	332	1157	1332	177	212	699	1306	974	490	1334
SHE40-160/40	2	100	100	244	471	332	1157	1332	177	212	699	1306	974	490	1334
SHE40-200/55	2	100	100	244	471	352	1177	1332	177	240	747	1354	974	490	1334
SHE40-200/75	2	100	100	244	471	352	1177	1332	177	240	747	1354	974	490	1334
SHE40-250/92	2	100	100	244	471	352	1177	1332	177	260	812	1419	1571	490	1334
SHE40-250/110	2	100	100	244	471	352	1177	1332	177	260	812	1419	1571	490	1334
SHE40-250/150	2	100	100	244	568	352	1274	1332	177	260	812	1419	1571	490	1334
SHE50-125/22	2	150	125	246	471	379	1239	1332	177	212	737	1357	974	490	1334
SHE50-125/30	2	150	125	246	471	379	1239	1332	177	212	737	1357	974	490	1334
SHE50-125/40	2	150	125	246	471	379	1239	1332	177	212	737	1357	974	490	1334
SHE50-160/55	2	150	125	246	471	379	1239	1332	177	240	785	1405	974	490	1334
SHE50-160/75	2	150	125	246	471	379	1239	1332	177	240	785	1405	974	490	1334
SHE50-200/92	2	150	125	246	471	379	1239	1332	177	240	805	1425	1571	490	1334
SHE50-200/110	2	150	125	246	471	379	1239	1332	177	240	805	1425	1571	490	1334
SHE50-250/150	2	150	125	246	568	379	1336	1332	177	260	850	1470	1571	490	1334
SHE50-250/185	2	150	125	285	815	379	1622	1332	355	300	890	1510	1571	490	1690
SHE50-250/220	2	150	125	285	815	379	1622	1332	355	300	890	1510	1571	490	1690
SHE65-160/40	3	200	150	246	471	589	1476	1332	177	240	1054	1688	974	490	1334
SHE65-160/55	3	200	150	246	471	589	1476	1332	177	240	1054	1688	974	490	1334
SHE65-160/75	3	200	150	246	471	589	1476	1332	177	240	1054	1688	974	490	1334
SHE65-160/92	3	200	150	246	471	589	1476	1332	177	240	1054	1688	1571	490	1334
SHE65-160/110	3	200	150	246	471	589	1476	1332	177	240	1054	1688	1571	490	1334
SHE65-200/150	3	200	150	246	568	589	1573	1332	177	260	1099	1733	1571	490	1334
SHE65-200/185	3	200	150	285	815	589	1859	1332	355	300	1139	1773	1571	490	1690
SHE65-200/220	3	200	150	285	815	589	1859	1332	355	300	1139	1773	1571	490	1690
SHE80-160/110	3	250	200	246	471	687	1606	1472	177	260	1166	1825	1571	490	1334
SHE80-160/150	3	250	200	246	568	687	1703	1472	177	260	1166	1825	1571	490	1334
SHE80-160/185	3	250	200	285	815	687	1989	1472	355	300	1206	1865	1571	490	1690
SHE80-200/220	3	250	200	285	815	687	1989	1472	355	300	1231	1890	1571	490	1690

Dimensions in mm. Tolerance ± 10 mm.

gs21_she-en_b_td

**TWO-PUMP BOOSTER SETS, GSD21 RA SERIES
HORIZONTAL ELECTRIC PUMPS WITH JOCKEY PUMP
NON-RETURN VALVE ON SUCTION SIDE**

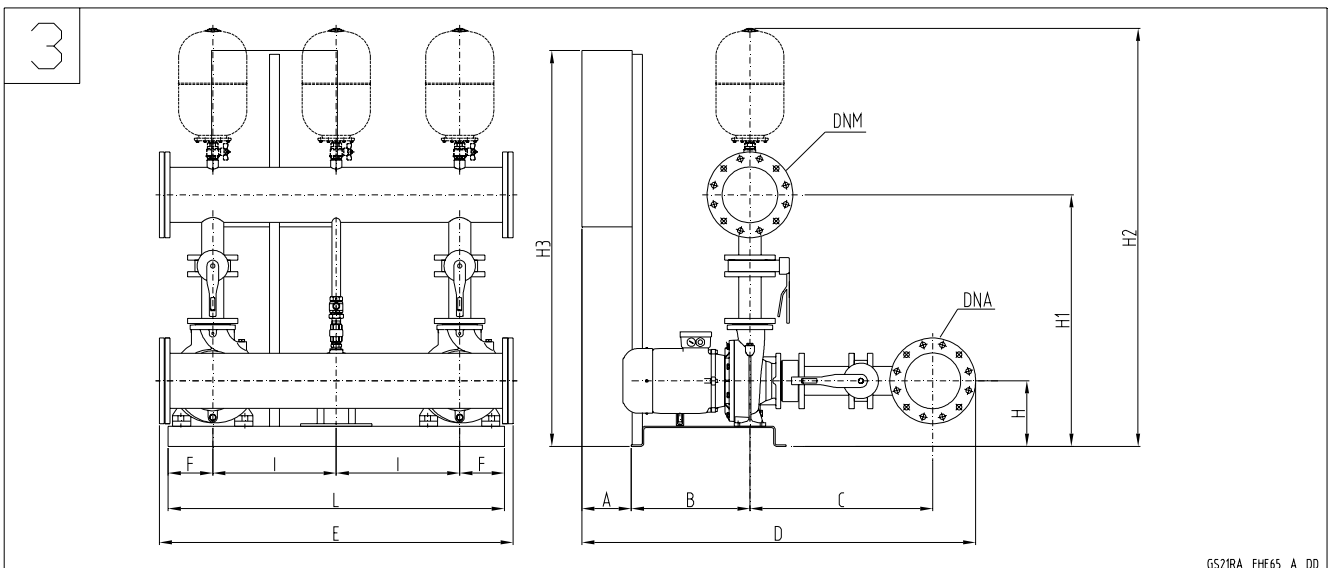
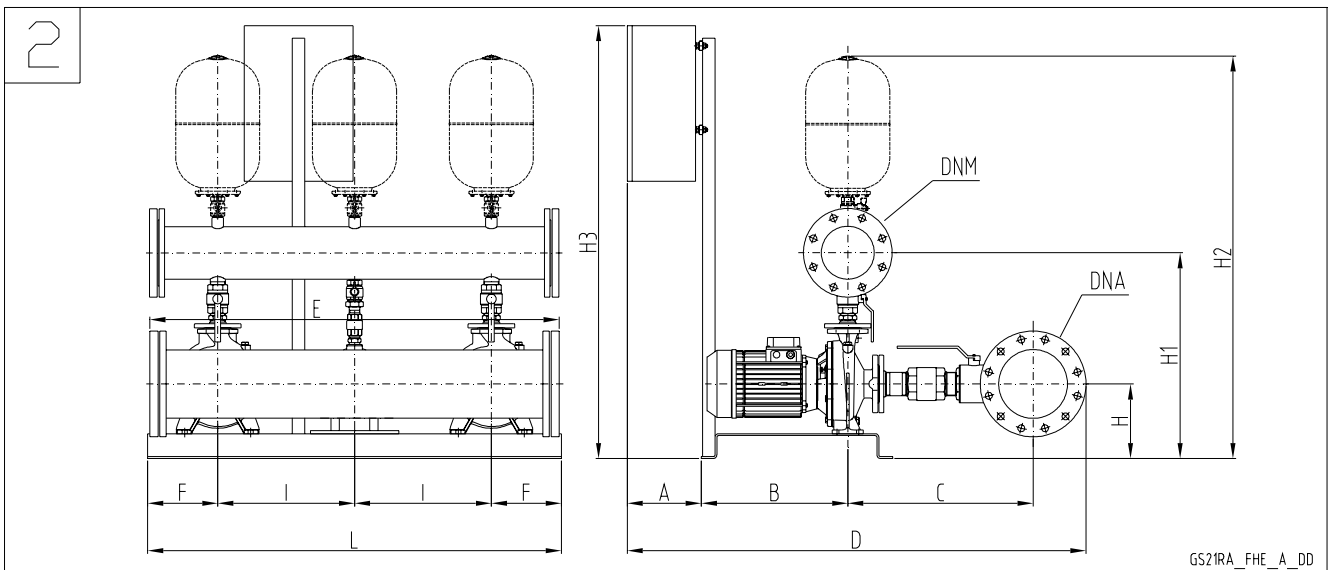
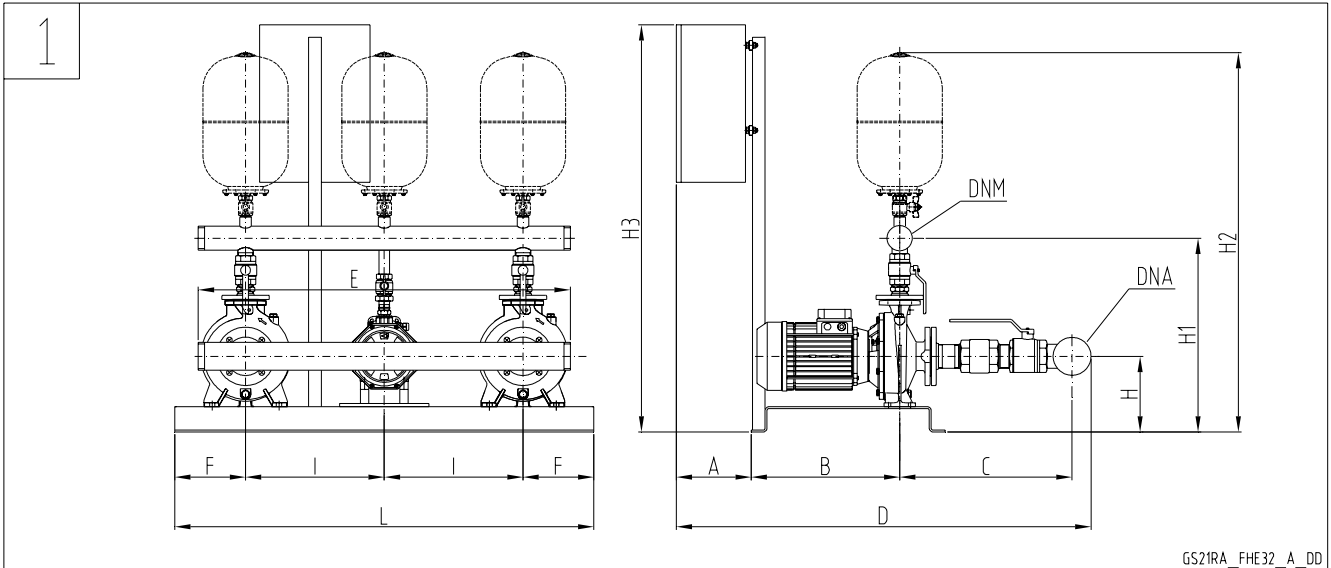

GS.../SH

**TWO-PUMP BOOSTER SETS, GSD21 RA SERIES
HORIZONTAL ELECTRIC PUMPS WITH JOCKEY PUMP
NON-RETURN VALVE ON SUCTION SIDE**

GSD21RA	DRW N°	DNA	DNM	A	B	C	D	E	F	H	H1	H2	H3	I	L
SHE25-200/40	1	80	65	242	302	425	1013	1092	128	240	533	1121	973	370	995
SHE25-250/55	1	80	65	242	302	445	1033	1092	128	260	598	1186	973	370	995
SHE25-250/75	1	80	65	242	302	445	1033	1092	128	260	598	1186	973	370	995
SHE25-250/110	1	80	65	242	302	445	1033	1092	128	260	598	1186	973	370	995
SHE32-125/07	1	80	65	242	302	425	1013	1092	128	192	496	1084	973	370	995
SHE32-125/11	1	80	65	242	302	425	1013	1092	128	192	496	1084	973	370	995
SHE32-160/15	1	80	65	242	302	425	1013	1092	128	212	536	1124	973	370	995
SHE32-160/22	1	80	65	242	302	425	1013	1092	128	212	536	1124	973	370	995
SHE32-200/30	1	80	65	242	302	425	1013	1092	128	240	584	1172	973	370	995
SHE32-200/40	1	80	65	242	302	425	1013	1092	128	240	584	1172	973	370	995
SHE32-250/55	1	80	65	242	300	445	1031	1092	128	260	649	1237	973	370	995
SHE32-250/75	1	80	65	242	300	445	1031	1092	128	260	649	1237	973	370	995
SHE32-250/110	1	80	65	242	300	445	1031	1092	128	260	649	1237	973	370	995
SHE40-125/11	2	100	100	246	471	514	1341	1332	177	192	548	1155	974	490	1334
SHE40-125/15	2	100	100	244	471	514	1339	1332	177	192	548	1155	974	490	1334
SHE40-125/22	2	100	100	244	471	514	1339	1332	177	192	548	1155	974	490	1334
SHE40-160/30	2	100	100	244	471	514	1339	1332	177	212	588	1195	974	490	1334
SHE40-160/40	2	100	100	244	471	514	1339	1332	177	212	588	1195	974	490	1334
SHE40-200/55	2	100	100	244	471	534	1359	1332	177	240	636	1243	974	490	1334
SHE40-200/75	2	100	100	244	471	534	1359	1332	177	240	636	1243	974	490	1334
SHE40-250/92	2	100	100	244	471	534	1359	1332	177	260	701	1308	1571	490	1334
SHE40-250/110	2	100	100	244	471	534	1359	1332	177	260	701	1308	1571	490	1334
SHE40-250/150	2	100	100	244	568	534	1456	1332	177	260	701	1308	1571	490	1334
SHE50-125/22	2	150	125	246	471	561	1421	1332	177	212	624	1244	974	490	1334
SHE50-125/30	2	150	125	246	471	561	1421	1332	177	212	624	1244	974	490	1334
SHE50-125/40	2	150	125	246	471	561	1421	1332	177	212	624	1244	974	490	1334
SHE50-160/55	2	150	125	246	471	561	1421	1332	177	240	672	1292	974	490	1334
SHE50-160/75	2	150	125	246	471	561	1421	1332	177	240	672	1292	974	490	1334
SHE50-200/92	2	150	125	246	471	561	1421	1332	177	240	692	1312	1571	490	1334
SHE50-200/110	2	150	125	246	471	561	1421	1332	177	240	692	1312	1571	490	1334
SHE50-250/150	2	150	125	246	568	561	1518	1332	177	260	737	1357	1571	490	1334
SHE50-250/185	2	150	125	285	815	561	1804	1332	355	300	777	1397	1571	490	1690
SHE50-250/220	2	150	125	285	815	561	1804	1332	355	300	777	1397	1571	490	1690
SHE65-160/40	3	200	150	246	471	649	1536	1332	177	240	928	1562	974	490	1334
SHE65-160/55	3	200	150	246	471	649	1536	1332	177	240	928	1562	974	490	1334
SHE65-160/75	3	200	150	246	471	649	1536	1332	177	240	928	1562	974	490	1334
SHE65-160/92	3	200	150	246	471	649	1536	1332	177	240	928	1562	1571	490	1334
SHE65-160/110	3	200	150	246	471	649	1536	1332	177	240	928	1562	1571	490	1334
SHE65-200/150	3	200	150	246	568	649	1633	1332	177	260	973	1607	1571	490	1334
SHE65-200/185	3	200	150	285	815	649	1919	1332	355	300	1013	1647	1571	490	1690
SHE65-200/220	3	200	150	285	815	649	1919	1332	355	300	1013	1647	1571	490	1690
SHE80-160/110	3	250	200	246	471	754	1673	1472	177	260	999	1658	1571	490	1334
SHE80-160/150	3	250	200	246	568	754	1770	1472	177	260	999	1658	1571	490	1334
SHE80-160/185	3	250	200	285	815	754	2056	1472	355	300	1039	1698	1571	490	1690
SHE80-200/220	3	250	200	285	815	754	2056	1472	355	300	1064	1723	1571	490	1690

Dimensions in mm. Tolerance ± 10 mm.

gs21ra_she-en_b_td

**TWO-PUMP BOOSTER SETS, GSY21 SERIES
HORIZONTAL ELECTRIC PUMPS WITH JOCKEY PUMP
NON-RETURN VALVE ON DISCHARGE SIDE**

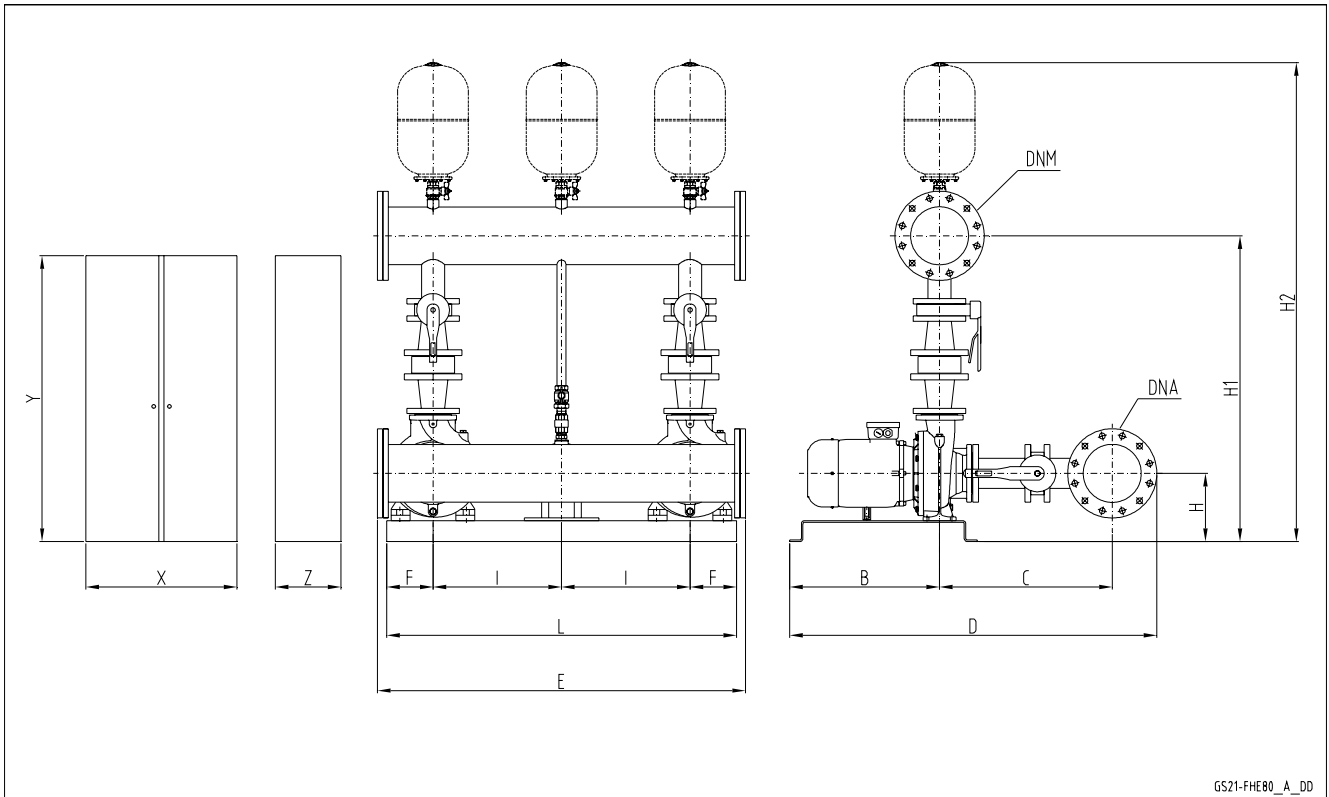

GSY21-FHE80_A_DD

GS.../SH

GSY21	DNA	DNM	B	C	D	E	F	H	H1	H2	I	L	X	Y	Z
SHS65-250/300	200	150	915	589	1674	1332	355	320	1184	1818	490	1690	600	1500	300
SHS65-250/370	200	150	915	589	1674	1332	355	320	1184	1818	490	1690	600	1500	300
SHS80-200/300	250	200	915	687	1804	1472	355	320	1251	1910	490	1690	600	1500	300
SHS80-200/370	250	200	915	687	1804	1472	355	320	1281	1940	490	1690	600	1500	300

Dimensions in mm. Tolerance ± 10 mm.

gs21_she80-en_b_td

**TWO-PUMP BOOSTER SETS, GSY21 RA SERIES
HORIZONTAL ELECTRIC PUMPS WITH JOCKEY PUMP
NON-RETURN VALVE ON SUCTION SIDE**

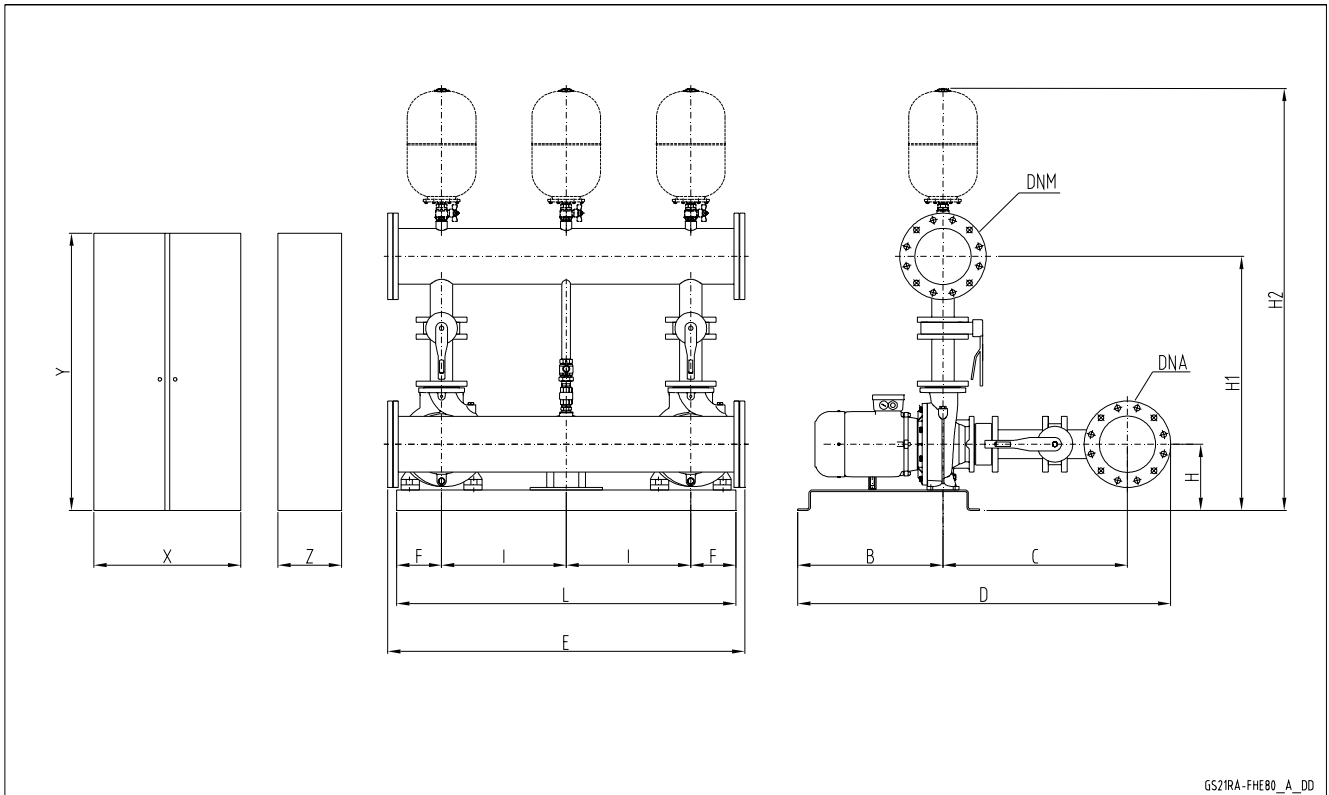

GS21RA-FHE80_A_DD

GS.../SH

GSY21RA	DNA	DNM	B	C	D	E	F	H	H1	H2	I	L	X	Y	Z
SHS65-250/300	200	150	915	649	1734	1332	355	320	1058	1692	490	1690	600	1500	300
SHS65-250/370	200	150	915	649	1734	1332	355	320	1058	1692	490	1690	600	1500	300
SHS80-200/300	250	200	915	754	1871	1472	355	320	1084	1743	490	1690	600	1500	300
SHS80-200/370	250	200	915	754	1871	1472	355	320	1114	1773	490	1690	600	1500	300

Dimensions in mm. Tolerance ± 10 mm.

gs21ra_she80-en_b_td

Booster sets

MARKET SECTORS CIVIL, INDUSTRIAL

APPLICATIONS

- Water network supply in condominiums, offices, hotels, shopping centres, factories.
- Water supply to agricultural water networks (e.g. irrigation).

GSD30 - GSY30 Series

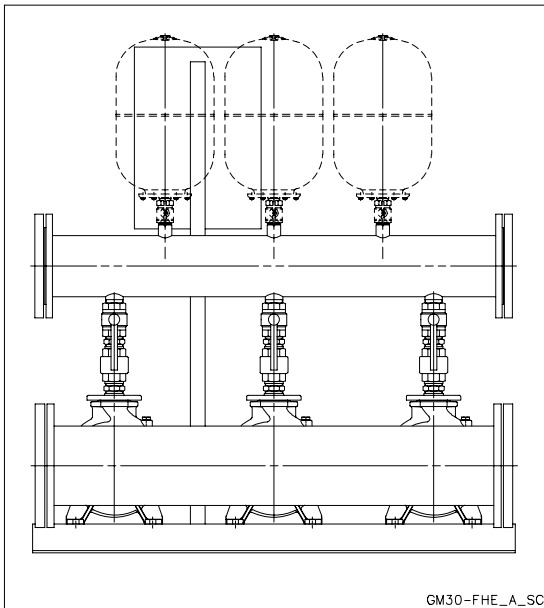

SPECIFICATIONS

- **Flow rate** up to 666 m³/h.
- **Head** up to 100 m.
- Electrical panel supply voltage:
3 x 400V ± 10%.
- Frequency 50 Hz.
- Voltage for controls outside panel:
24 Vac.
- Electrical panel protection class IP 55.
- Maximum service pump power:
3 x 37 kW.
- **Motor start-up:**
 - Direct for powers up to 22 kW inclusive for pump (GSD/).
 - Star/Delta for higher powers (GSY/ set).
 - Softstarter, available on request (GSR../ set).
- **Electric pumps with horizontal axis:**
 - SH series (motor protection class IP55).
- Maximum operating pressure:
16 bar.
- Maximum temperature of pumped liquid : +80°C.

**THREE-PUMP BOOSTER SETS, GSD30 SERIES
HORIZONTAL ELECTRIC PUMPS WITH NON-RETURN VALVE
ON DISCHARGE SIDE**

GS.../SH

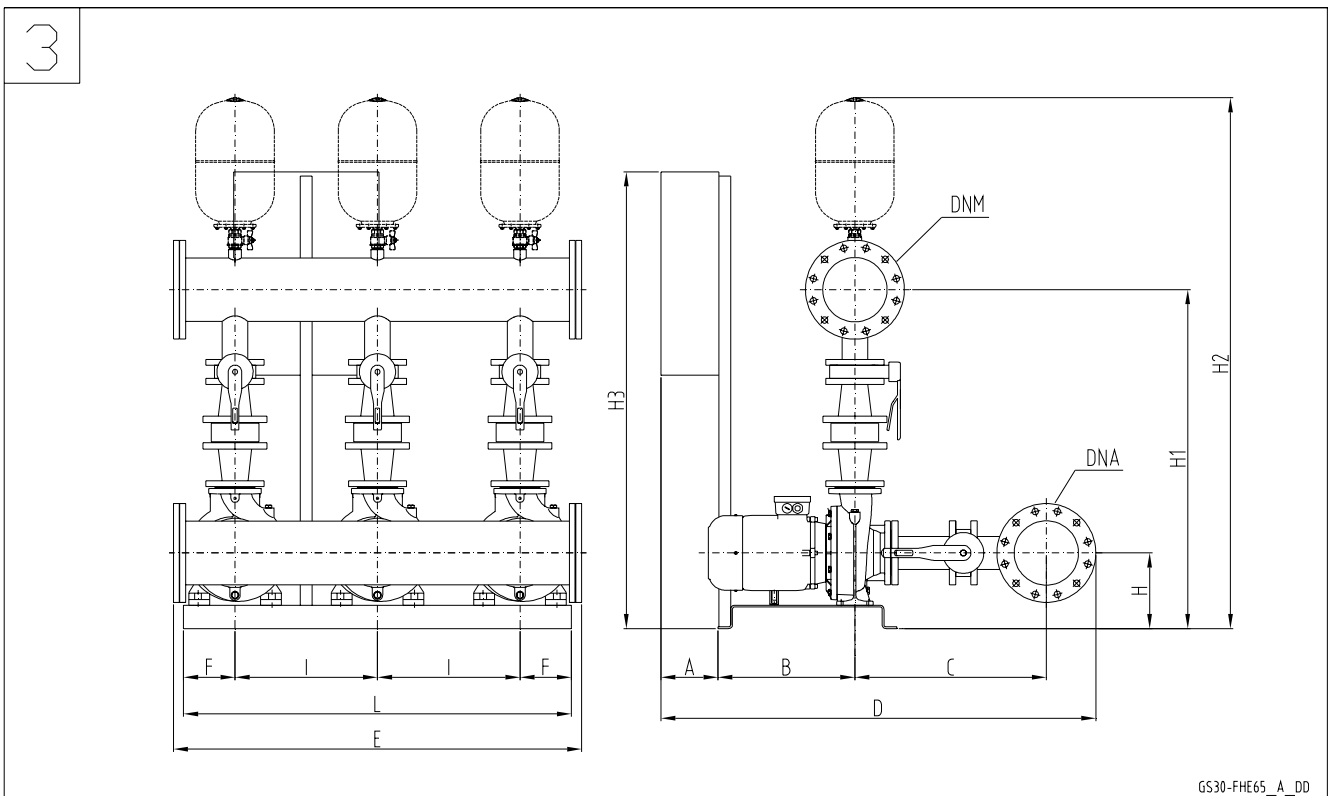
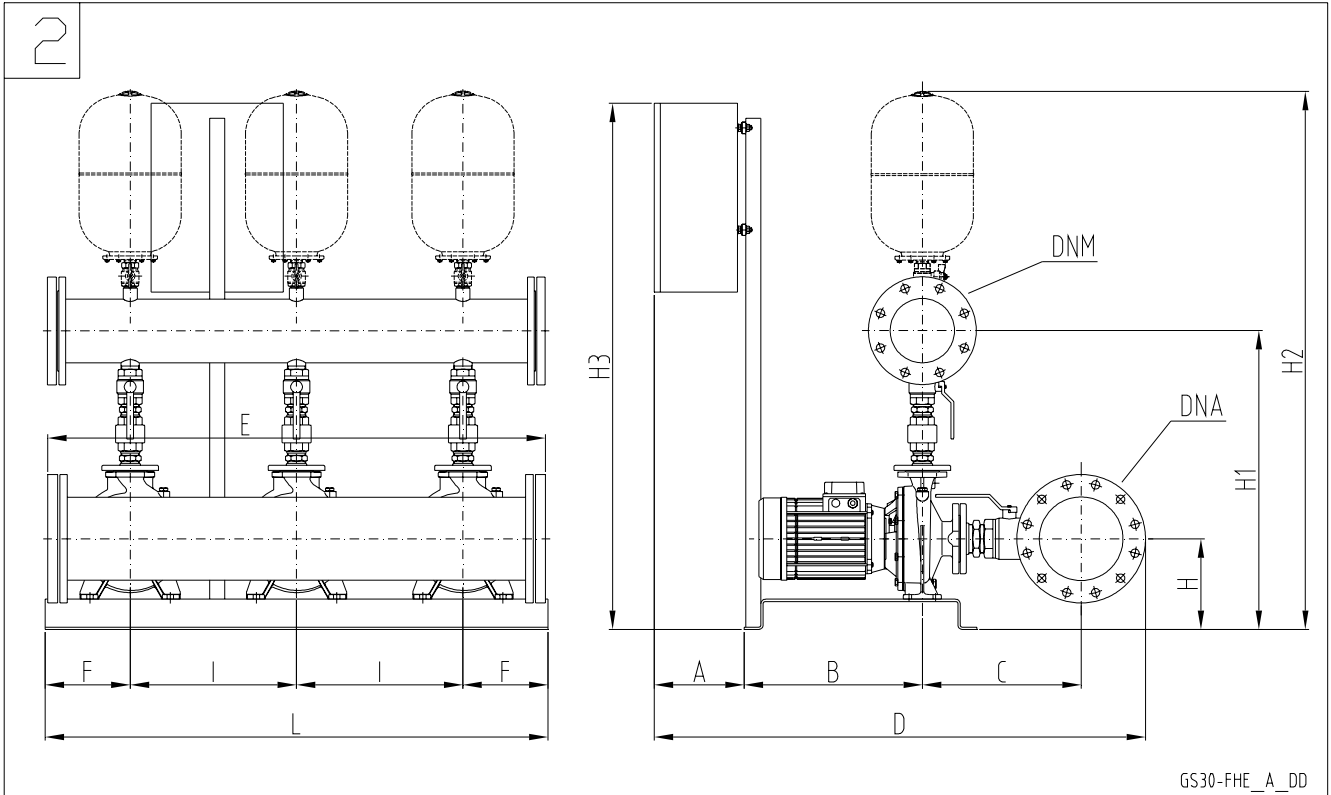

THREE-PUMP BOOSTER SETS, GSD30 SERIES HORIZONTAL ELECTRIC PUMPS WITH NON-RETURN VALVE ON DISCHARGE SIDE

GSD30	DRW N°	DNA	DNM	A	B	C	D	E	F	H	H1	H2	H3	I	L
SHE25-200/40	2	100	80	242	302	302	956	1092	128	240	645	1239	973	370	995
SHE25-250/55	2	100	80	242	302	322	976	1092	128	260	710	1304	973	370	995
SHE25-250/75	2	100	80	242	302	322	976	1092	128	260	710	1304	973	370	995
SHE25-250/110	2	100	80	242	302	322	976	1092	128	260	710	1304	973	370	995
SHE32-125/07	2	100	80	242	302	317	971	1092	128	192	608	1202	973	370	995
SHE32-125/11	2	100	80	242	302	317	971	1092	128	192	608	1202	973	370	995
SHE32-160/15	2	100	80	242	302	317	971	1092	128	212	648	1242	973	370	995
SHE32-160/22	2	100	80	242	302	317	971	1092	128	212	648	1242	973	370	995
SHE32-200/30	2	100	80	242	302	317	971	1092	128	240	696	1290	973	370	995
SHE32-200/40	2	100	80	242	302	317	971	1092	128	240	696	1290	973	370	995
SHE32-250/55	2	100	80	242	300	337	989	1092	128	260	761	1355	973	370	995
SHE32-250/75	2	100	80	242	300	337	989	1092	128	260	761	1355	973	370	995
SHE32-250/110	2	100	80	242	300	337	989	1092	128	260	761	1355	973	370	995
SHE40-125/11	2	125	125	246	471	345	1187	1332	177	192	672	1292	974	490	1334
SHE40-125/15	2	125	125	244	471	345	1185	1332	177	192	672	1292	974	490	1334
SHE40-125/22	2	125	125	244	471	345	1185	1332	177	192	672	1292	974	490	1334
SHE40-160/30	2	125	125	244	471	345	1185	1332	177	212	712	1332	974	490	1334
SHE40-160/40	2	125	125	244	471	345	1185	1332	177	212	712	1332	974	490	1334
SHE40-200/55	2	125	125	244	471	365	1205	1332	177	240	760	1380	974	490	1334
SHE40-200/75	2	125	125	244	471	365	1205	1332	177	240	760	1380	974	490	1334
SHE40-250/92	2	125	125	244	471	365	1205	1332	177	260	825	1445	1571	490	1334
SHE40-250/110	2	125	125	244	471	365	1205	1332	177	260	825	1445	1571	490	1334
SHE40-250/150	2	125	125	244	568	365	1302	1332	177	260	825	1445	1571	490	1334
SHE50-125/22	2	200	150	246	471	405	1292	1332	177	212	751	1385	974	490	1334
SHE50-125/30	2	200	150	246	471	405	1292	1332	177	212	751	1385	974	490	1334
SHE50-125/40	2	200	150	246	471	405	1292	1332	177	212	751	1385	974	490	1334
SHE50-160/55	2	200	150	246	471	405	1292	1332	177	240	799	1433	974	490	1334
SHE50-160/75	2	200	150	246	471	405	1292	1332	177	240	799	1433	974	490	1334
SHE50-200/92	2	200	150	246	471	405	1292	1332	177	240	819	1453	1571	490	1334
SHE50-200/110	2	200	150	246	471	405	1292	1332	177	240	819	1453	1571	490	1334
SHE50-250/150	2	200	150	246	568	405	1389	1332	177	260	864	1498	1571	490	1334
SHE50-250/185	2	200	150	285	815	405	1675	1332	355	300	904	1538	1571	490	1690
SHE50-250/220	2	200	150	285	815	405	1675	1332	355	300	904	1538	1571	490	1690
SHE65-160/40	3	250	200	246	471	616	1535	1332	177	240	1080	1739	974	490	1334
SHE65-160/55	3	250	200	246	471	616	1535	1332	177	240	1080	1739	974	490	1334
SHE65-160/75	3	250	200	246	471	616	1535	1332	177	240	1080	1739	974	490	1334
SHE65-160/92	3	250	200	246	471	616	1535	1332	177	240	1080	1739	1571	490	1334
SHE65-160/110	3	250	200	246	471	616	1535	1332	177	240	1080	1739	1571	490	1334
SHE65-200/150	3	250	200	246	568	616	1632	1332	177	260	1125	1784	1571	490	1334
SHE65-200/185	3	250	200	285	815	616	1918	1332	355	300	1165	1824	1571	490	1690
SHE65-200/220	3	250	200	285	815	616	1918	1332	355	300	1165	1824	1571	490	1690
SHE80-160/110	3	300	250	246	471	712	1659	1472	177	260	1193	1879	1571	490	1334
SHE80-160/150	3	300	250	246	568	712	1756	1472	177	260	1193	1879	1571	490	1334
SHE80-160/185	3	300	250	285	815	712	2042	1472	355	300	1233	1919	1571	490	1690
SHE80-200/220	3	300	250	285	815	712	2042	1472	355	300	1258	1944	1571	490	1690

Dimensions in mm. Tolerance ± 10 mm.

gs30_she-en_b_td

**THREE-PUMP BOOSTER SETS, GSD30 RA SERIES
HORIZONTAL ELECTRIC PUMPS WITH NON-RETURN VALVE
ON SUCTION SIDE**

2

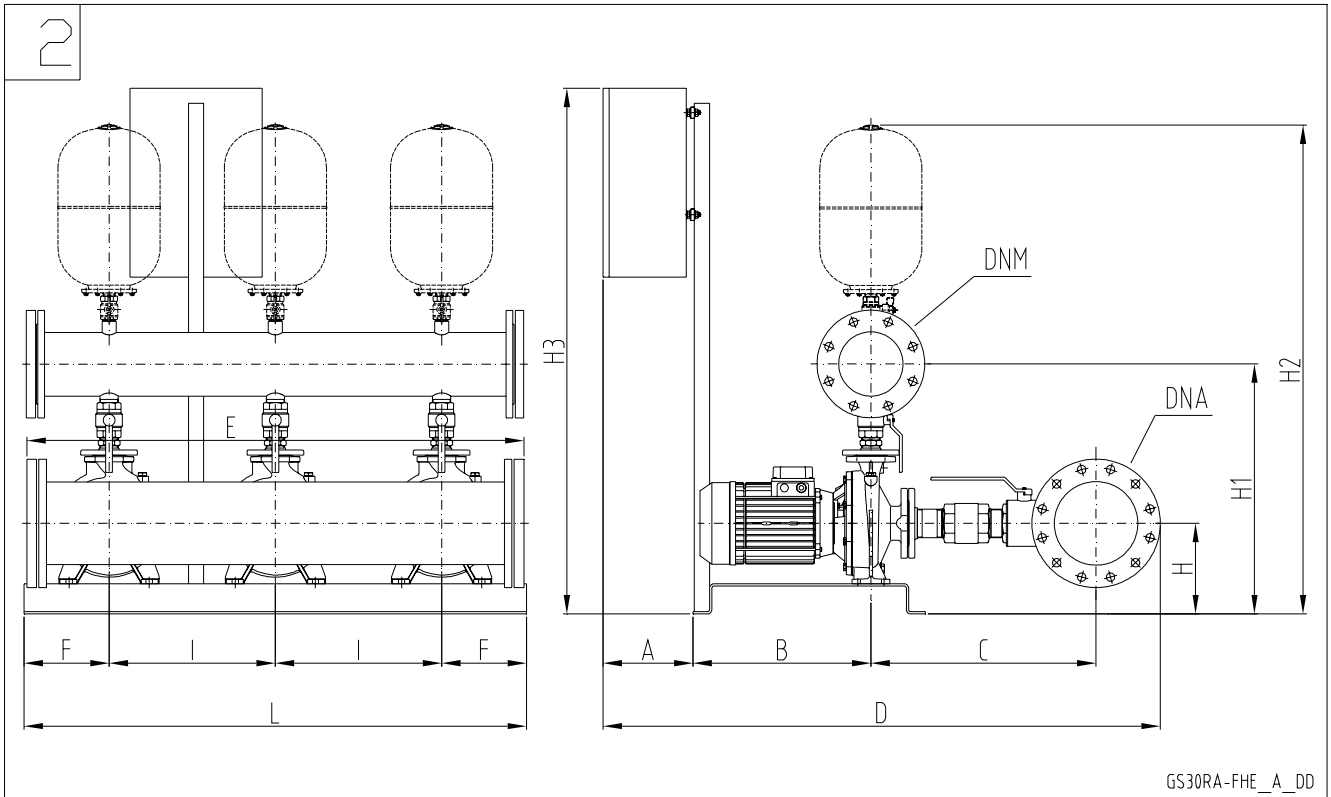

GS30RA-FHE_A_DD

3

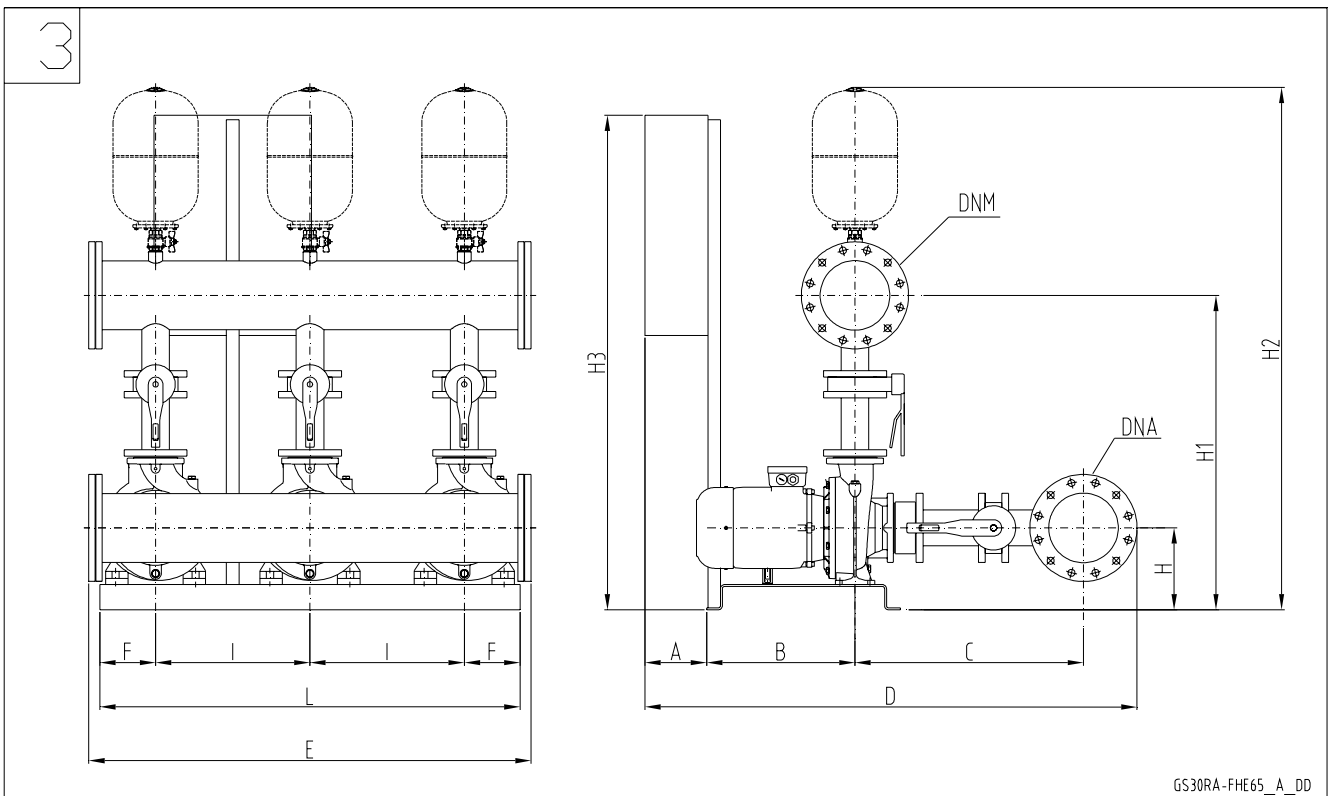

GS30RA-FHE65_A_DD

GS.../SH

THREE-PUMP BOOSTER SETS, GSD30 RA SERIES HORIZONTAL ELECTRIC PUMPS WITH NON-RETURN VALVE ON SUCTION SIDE

GSD30RA	DRW N°	DNA	DNM	A	B	C	D	E	F	H	H1	H2	H3	I	L
SHE25-200/40	2	100	80	242	302	437	1091	1092	128	240	540	1134	973	370	995
SHE25.250/55	2	100	80	242	302	457	1111	1092	128	260	605	1199	973	370	995
SHE25-250/75	2	100	80	242	302	457	1111	1092	128	260	605	1199	973	370	995
SHE25-250/110	2	100	80	242	302	457	1111	1092	128	260	605	1199	973	370	995
SHE32-125/07	2	100	80	242	302	437	1091	1092	128	192	503	1097	973	370	995
SHE32-125/11	2	100	80	242	302	437	1091	1092	128	192	503	1097	973	370	995
SHE32-160/15	2	100	80	242	302	437	1091	1092	128	212	543	1137	973	370	995
SHE32-160/22	2	100	80	242	302	437	1091	1092	128	212	543	1137	973	370	995
SHE32-200/30	2	100	80	242	302	437	1091	1092	128	240	591	1185	973	370	995
SHE32-200/40	2	100	80	242	302	437	1091	1092	128	240	591	1185	973	370	995
SHE32-250/55	2	100	80	242	300	457	1109	1092	128	260	656	1250	973	370	995
SHE32-250/75	2	100	80	242	300	457	1109	1092	128	260	656	1250	973	370	995
SHE32-250/110	2	100	80	242	300	457	1109	1092	128	260	656	1250	973	370	995
SHE40-125/11	2	125	125	246	471	527	1369	1332	177	192	561	1181	974	490	1334
SHE40-125/15	2	125	125	244	471	527	1367	1332	177	192	561	1181	974	490	1334
SHE40-125/22	2	125	125	244	471	527	1367	1332	177	192	561	1181	974	490	1334
SHE40-160/30	2	125	125	244	471	527	1367	1332	177	212	601	1221	974	490	1334
SHE40-160/40	2	125	125	244	471	527	1367	1332	177	212	601	1221	974	490	1334
SHE40-200/55	2	125	125	244	471	547	1387	1332	177	240	649	1269	974	490	1334
SHE40-200/75	2	125	125	244	471	547	1387	1332	177	240	649	1269	974	490	1334
SHE40-250/92	2	125	125	244	471	547	1387	1332	177	260	714	1334	1571	490	1334
SHE40-250/110	2	125	125	244	471	547	1387	1332	177	260	714	1334	1571	490	1334
SHE40-250/150	2	125	125	244	568	547	1484	1332	177	260	714	1334	1571	490	1334
SHE50-125/22	2	200	150	246	471	587	1474	1332	177	212	638	1272	974	490	1334
SHE50-125/30	2	200	150	246	471	587	1474	1332	177	212	638	1272	974	490	1334
SHE50-125/40	2	200	150	246	471	587	1474	1332	177	212	638	1272	974	490	1334
SHE50-160/55	2	200	150	246	471	587	1474	1332	177	240	686	1320	974	490	1334
SHE50-160/75	2	200	150	246	471	587	1474	1332	177	240	686	1320	974	490	1334
SHE50-200/92	2	200	150	246	471	587	1474	1332	177	240	706	1340	1571	490	1334
SHE50-200/110	2	200	150	246	471	587	1474	1332	177	240	706	1340	1571	490	1334
SHE50-250/150	2	200	150	246	568	587	1571	1332	177	260	751	1385	1571	490	1334
SHE50-250/185	2	200	150	285	815	587	1857	1332	355	300	791	1425	1571	490	1690
SHE50-250/220	2	200	150	285	815	587	1857	1332	355	300	791	1425	1571	490	1690
SHE65-160/40	3	250	200	246	471	676	1595	1332	177	240	954	1613	974	490	1334
SHE65-160/55	3	250	200	246	471	676	1595	1332	177	240	954	1613	974	490	1334
SHE65-160/75	3	250	200	246	471	676	1595	1332	177	240	954	1613	974	490	1334
SHE65-160/92	3	250	200	246	471	676	1595	1332	177	240	954	1613	1571	490	1334
SHE65-160/110	3	250	200	246	471	676	1595	1332	177	240	954	1613	1571	490	1334
SHE65-200/150	3	250	200	246	568	676	1692	1332	177	260	999	1658	1571	490	1334
SHE65-200/185	3	250	200	285	815	676	1978	1332	355	300	1039	1698	1571	490	1690
SHE65-200/220	3	250	200	285	815	676	1978	1332	355	300	1039	1698	1571	490	1690
SHE80-160/110	3	300	250	246	471	779	1726	1472	177	260	1026	1712	1571	490	1334
SHE80-160/150	3	300	250	246	568	779	1823	1472	177	260	1026	1712	1571	490	1334
SHE80-160/185	3	300	250	285	815	779	2109	1472	355	300	1066	1752	1571	490	1690
SHE80-200/220	3	300	250	285	815	779	2109	1472	355	300	1091	1777	1571	490	1690

Dimensions in mm. Tolerance ± 10 mm.

gs30ra_she-en_b_td

**THREE-PUMP BOOSTER SETS, GSY30 SERIES
HORIZONTAL ELECTRIC PUMPS WITH NON-RETURN VALVE
ON DISCHARGE SIDE**

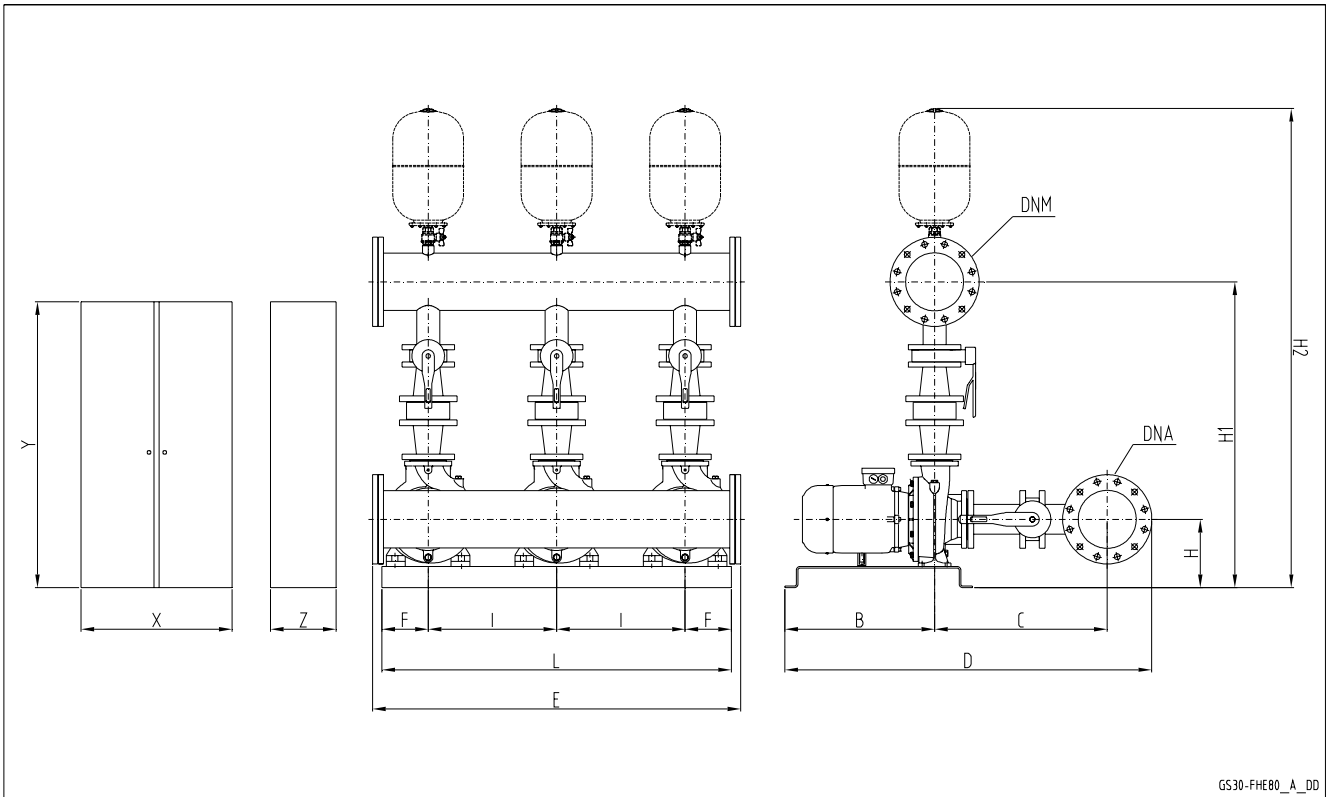

GSY30-FHE80_A_DD

GS.../SH

GSY30	DNA	DNM	B	C	D	E	F	H	H1	H2	I	L	X	Y	Z
SHS65-250/300	250	200	915	616	1733	1332	355	320	1210	1869	490	1690	600	1500	300
SHS65-250/370	250	200	915	616	1733	1332	355	320	1210	1869	490	1690	600	1500	300
SHS80-200/300	300	250	915	712	1857	1472	355	320	1278	1964	490	1690	600	1500	300
SHS80-200/370	300	250	915	712	1857	1472	355	320	1308	1994	490	1690	600	1500	300

Dimensions in mm. Tolerance ± 10 mm.

gs30_she80-en_b_td

**THREE-PUMP BOOSTER SETS, GSY30 RA SERIES
HORIZONTAL ELECTRIC PUMPS WITH NON-RETURN VALVE
ON SUCTION SIDE**

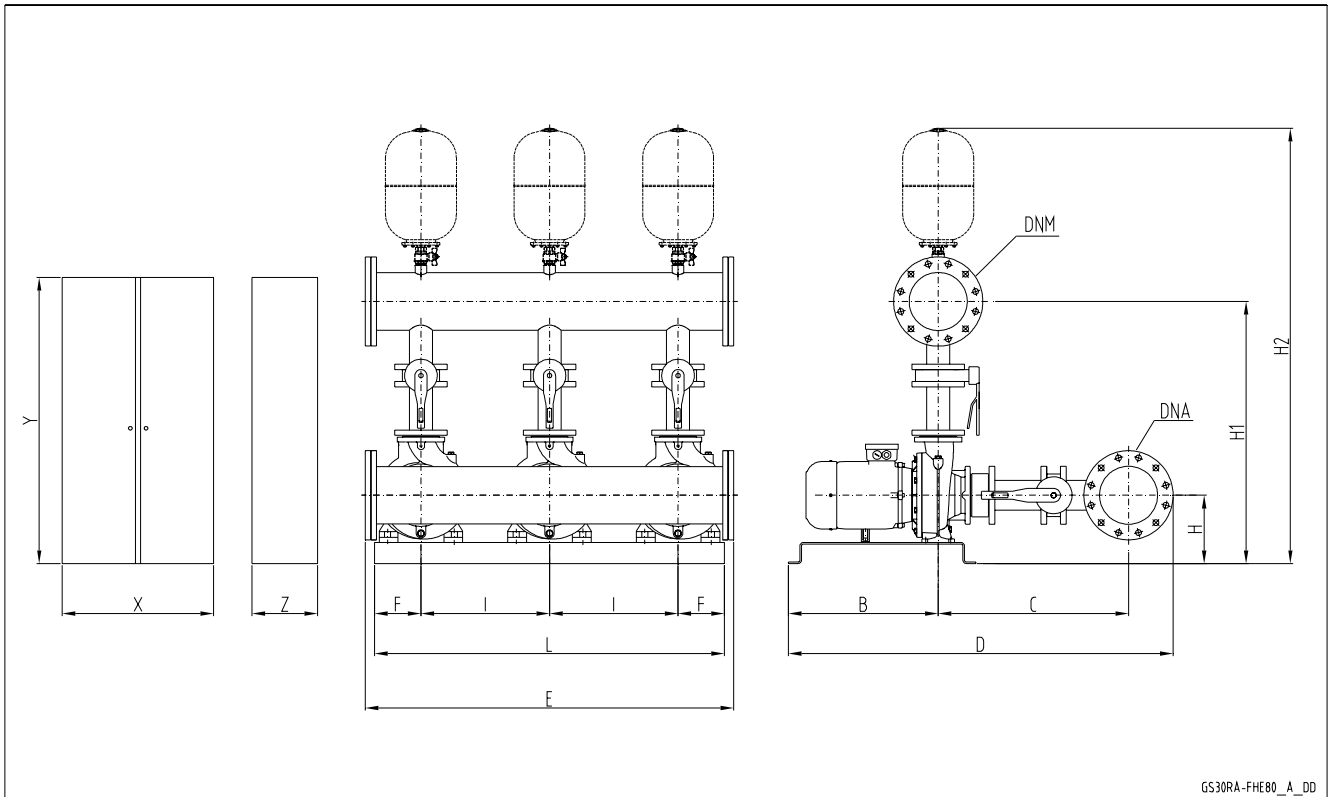

GS.../SH

GSY30RA	DNA	DNM	B	C	D	E	F	H	H1	H2	I	L	X	Y	Z
SHS65-250/300	250	200	915	676	1793	1332	355	320	1084	1743	490	1690	600	1500	300
SHS65-250/370	250	200	915	676	1793	1332	355	320	1084	1743	490	1690	600	1500	300
SHS80-200/300	300	250	915	779	1924	1472	355	320	1111	1797	490	1690	600	1500	300
SHS80-200/370	300	250	915	779	1924	1472	355	320	1141	1827	490	1690	600	1500	300

Dimensions in mm. Tolerance ± 10 mm.

gs30ra_she80-en_b_td

**BOOSTER SETS, GS.../SH SERIES
OPERATING CHARACTERISTICS AT 50 Hz (JOCKEY PUMP)**

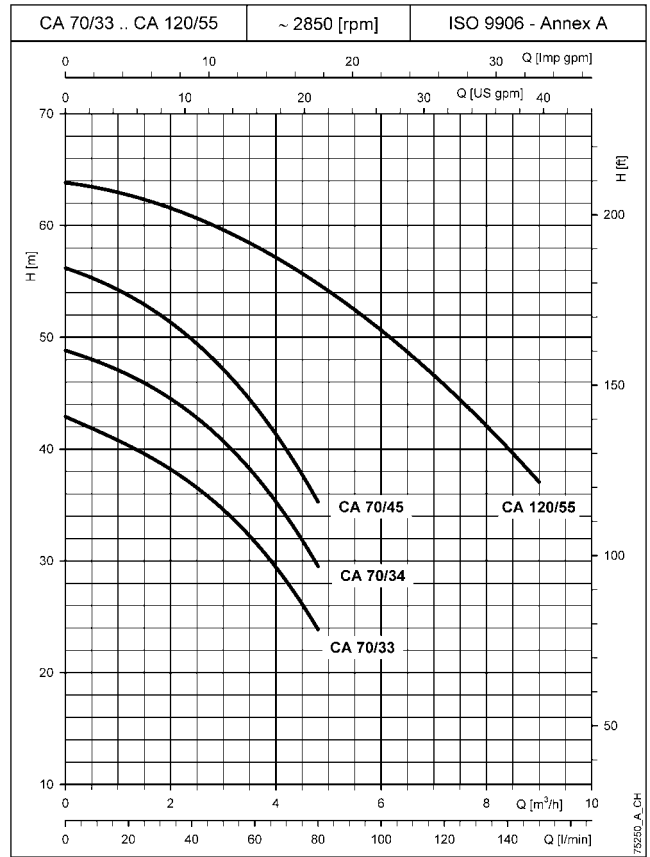
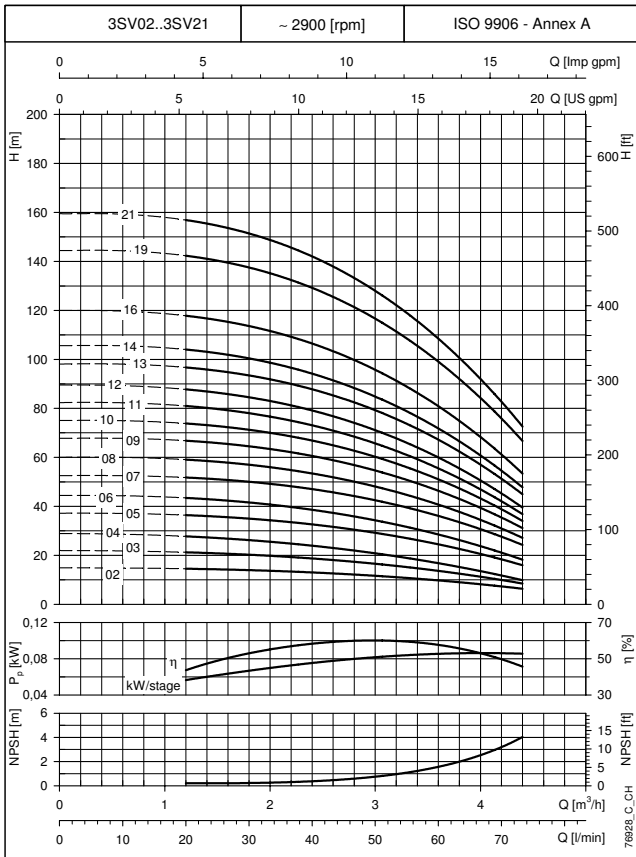

GS.../SH

The performance curves do not take into account flow resistance in the valves and piping.
The curves show performance with one pump running.
These performances are valid for liquids with density $\rho = 1.0 \text{ kg/dm}^3$ and kinematic viscosity $\nu = 1 \text{ mm}^2/\text{s}$.

BOOSTER SETS, GS.../SH SERIES OPERATING CHARACTERISTICS AT 50 Hz (SERVICE PUMP)

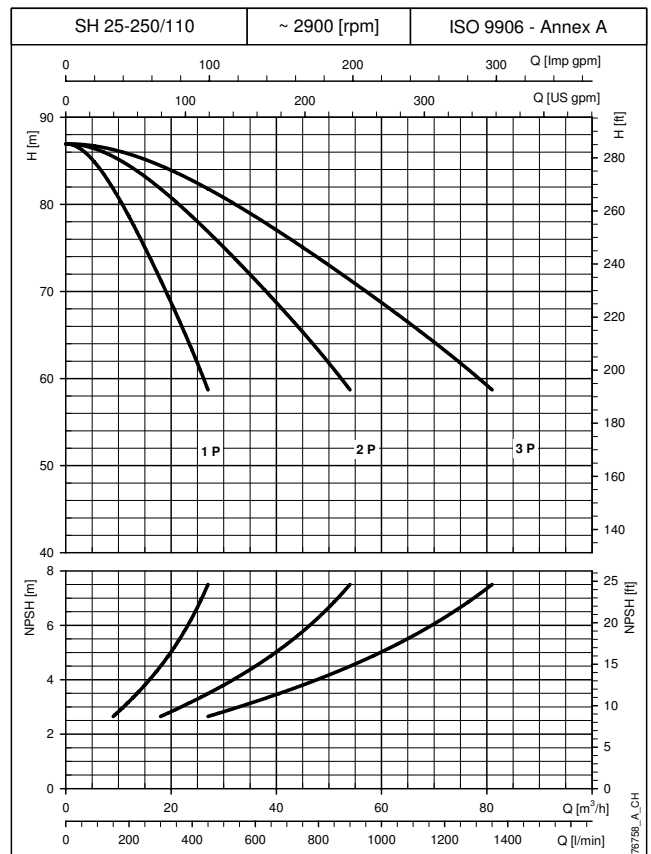
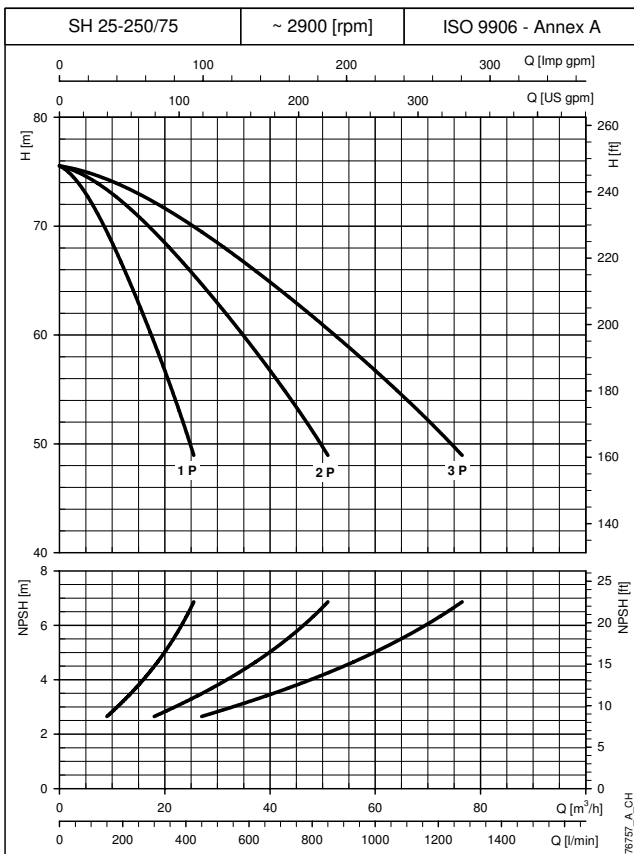
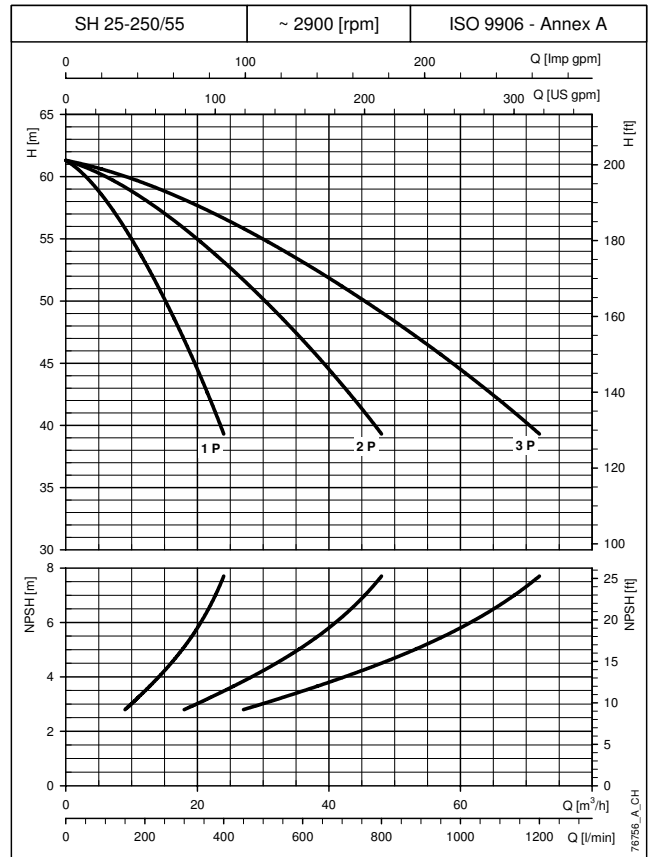
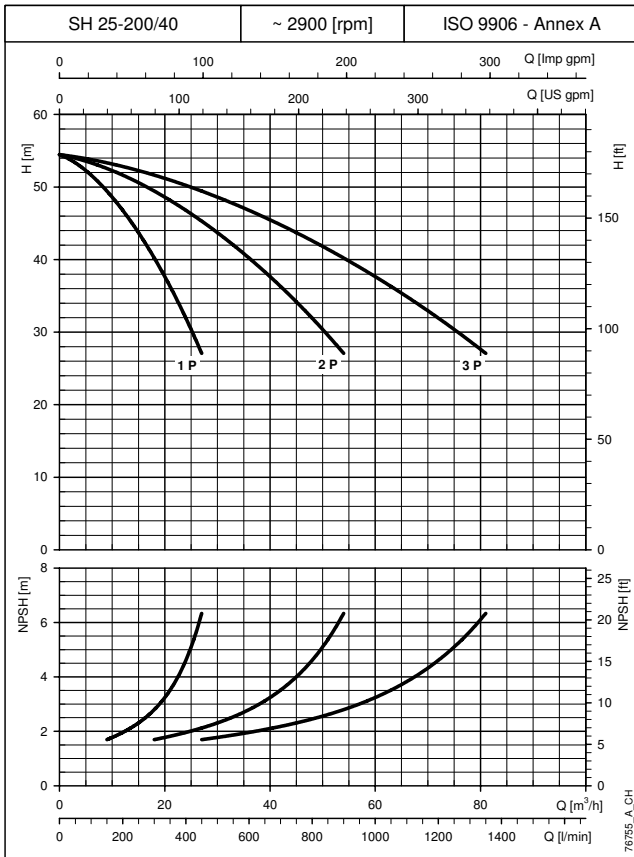

The performance curves do not take into account flow resistance in the valves and piping.
 The curves show the performance with one, two and three pumps running.
 These performances are valid for liquids with density $\rho = 1.0 \text{ Kg/dm}^3$ and kinematic viscosity $\nu = 1 \text{ mm}^2/\text{s}$.
 The declared NPSH values are laboratory values; for practical use we recommend increasing these values by 0.5 m.

GS.../SH

BOOSTER SETS, GS.../SH SERIES OPERATING CHARACTERISTICS AT 50 Hz (SERVICE PUMP)

GS.../SH

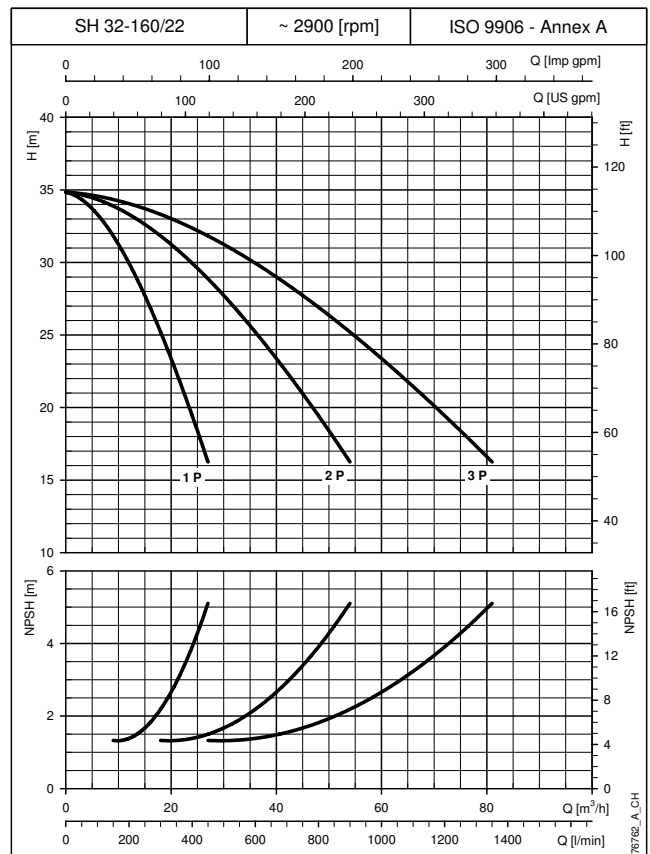
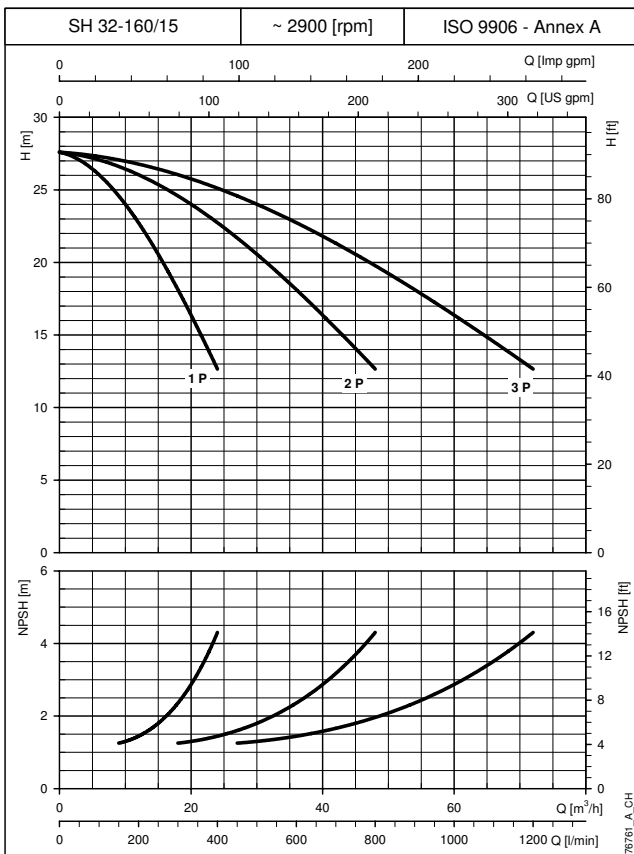
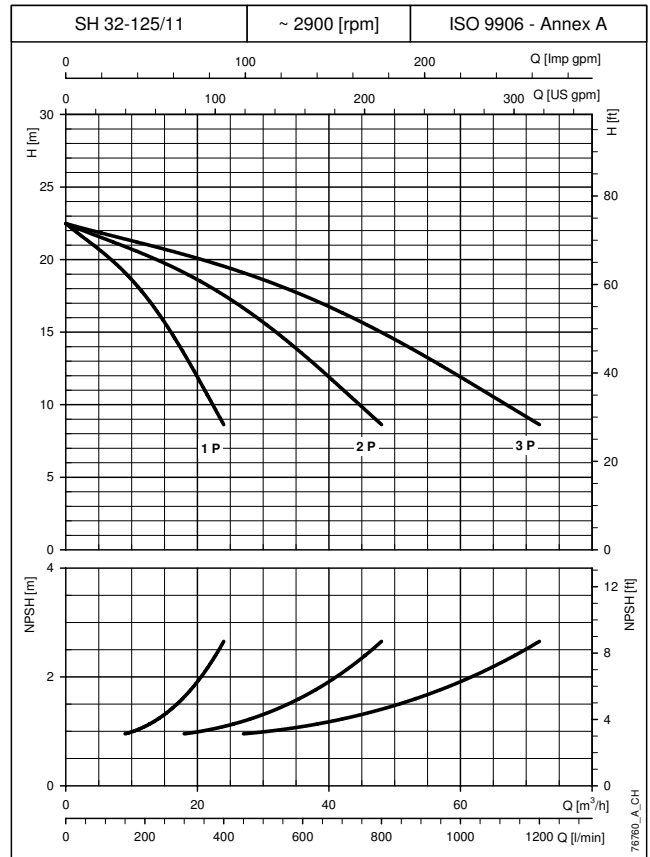
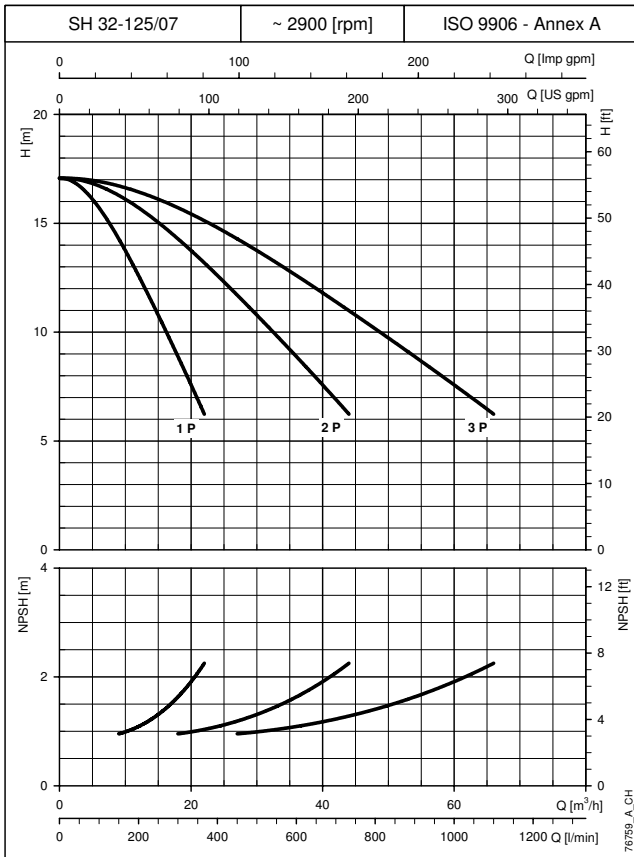

The performance curves do not take into account flow resistance in the valves and piping.
 The curves show the performance with one, two and three pumps running.
 These performances are valid for liquids with density $\rho = 1.0 \text{ Kg/dm}^3$ and kinematic viscosity $\nu = 1 \text{ mm}^2/\text{s}$.
 The declared NPSH values are laboratory values: for practical use we recommend increasing these values by 0.5 m.

BOOSTER SETS, GS.../SH SERIES OPERATING CHARACTERISTICS AT 50 Hz (SERVICE PUMP)

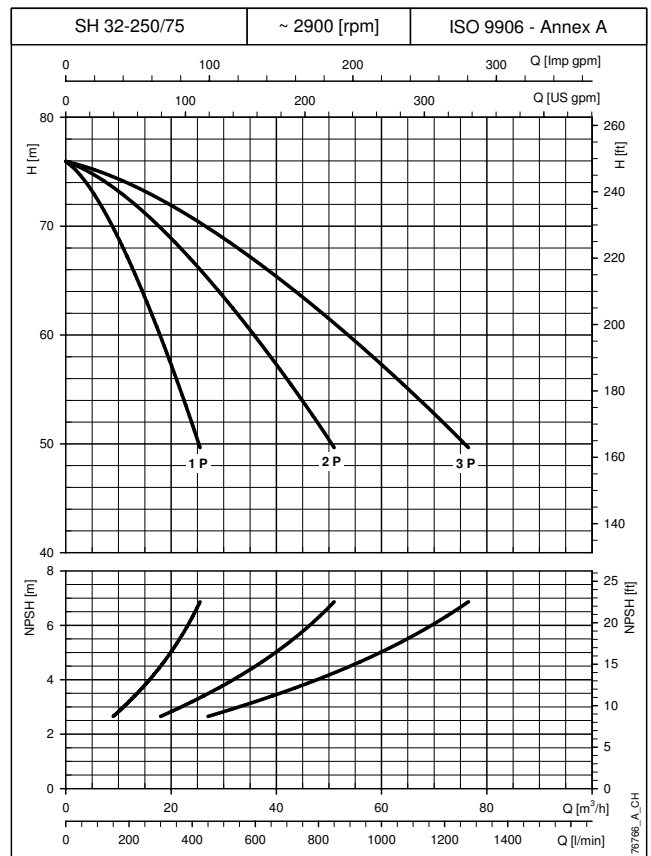
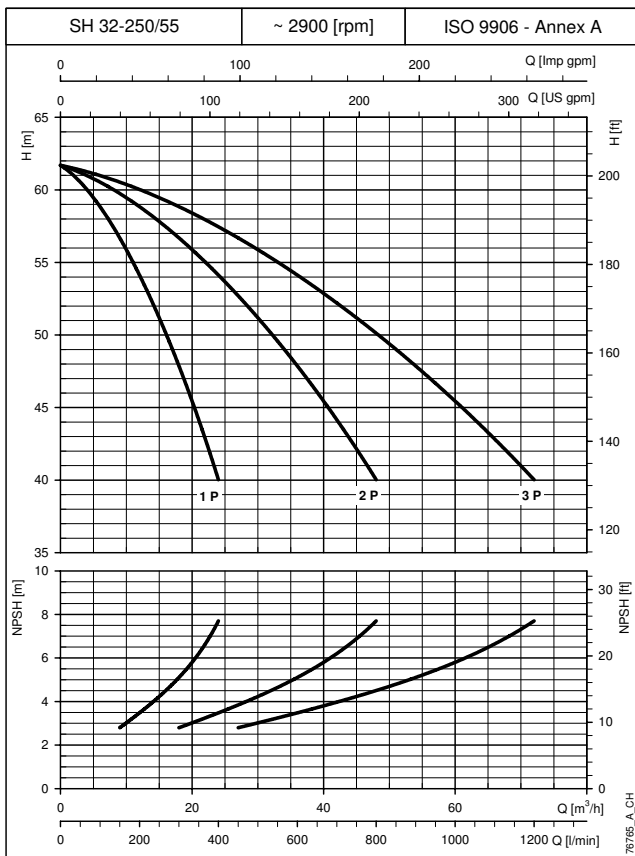
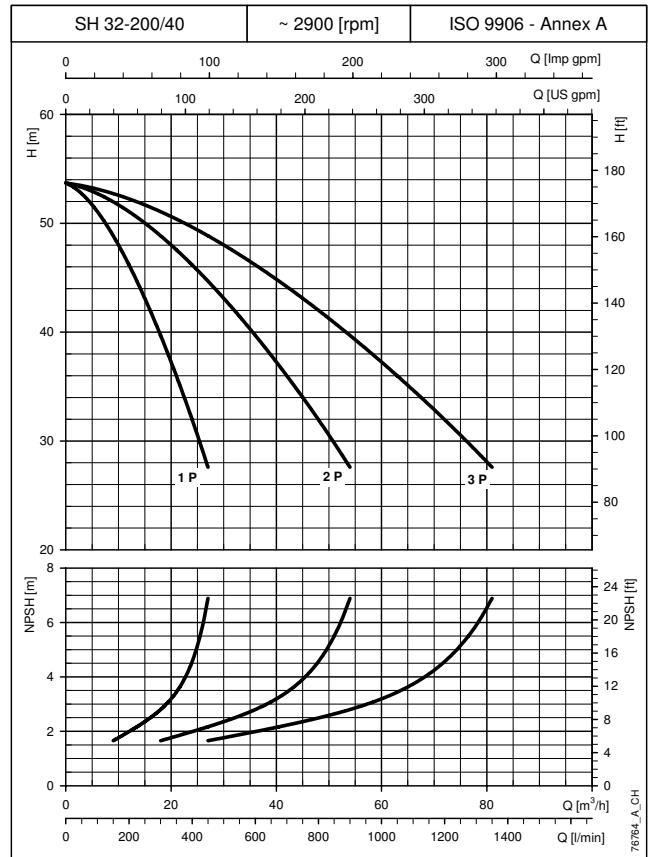
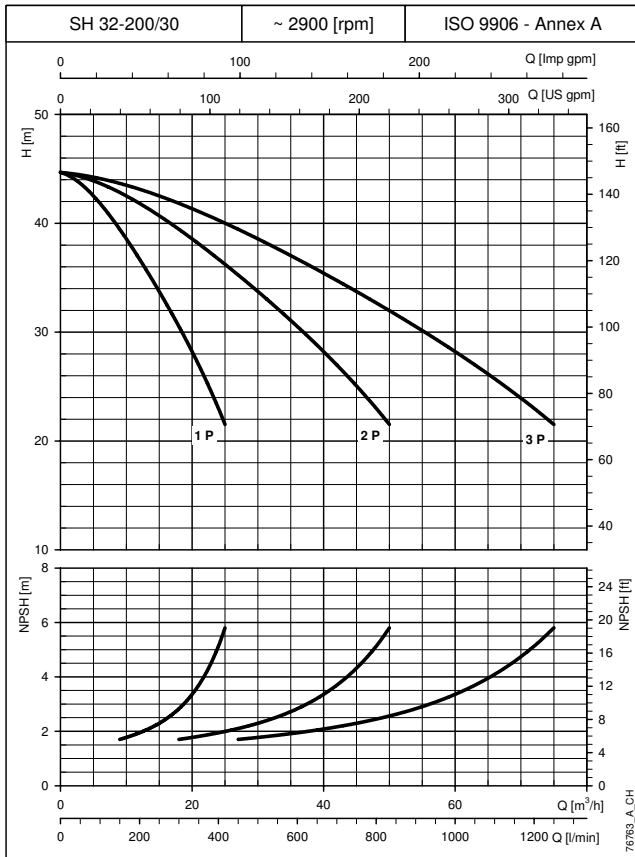

The performance curves do not take into account flow resistance in the valves and piping.
 The curves show the performance with one, two and three pumps running.
 These performances are valid for liquids with density $\rho = 1.0 \text{ Kg/dm}^3$ and kinematic viscosity $\nu = 1 \text{ mm}^2/\text{s}$.
 The declared NPSH values are laboratory values; for practical use we recommend increasing these values by 0.5 m.

GS.../SH

BOOSTER SETS, GS.../SH SERIES OPERATING CHARACTERISTICS AT 50 Hz (SERVICE PUMP)

GS.../SH

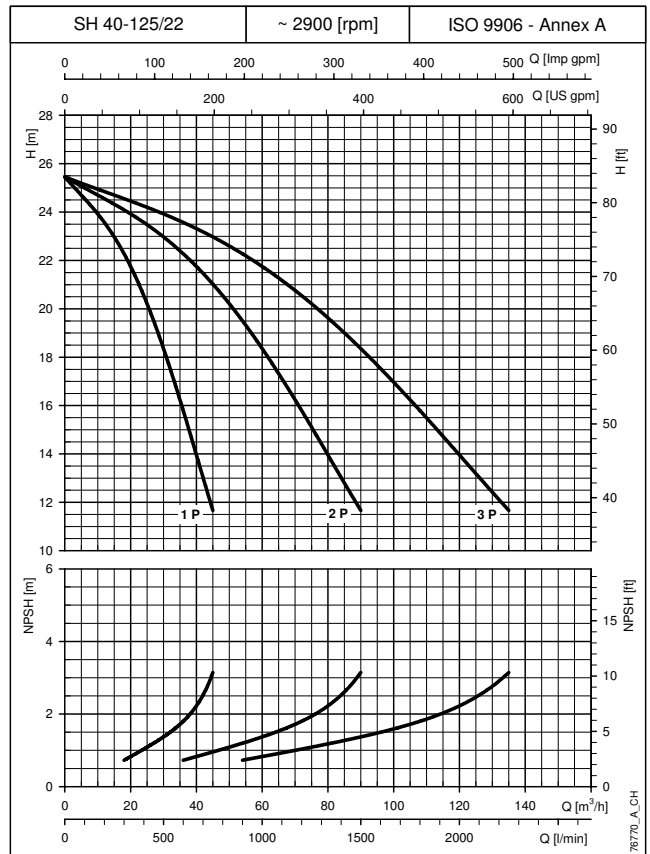
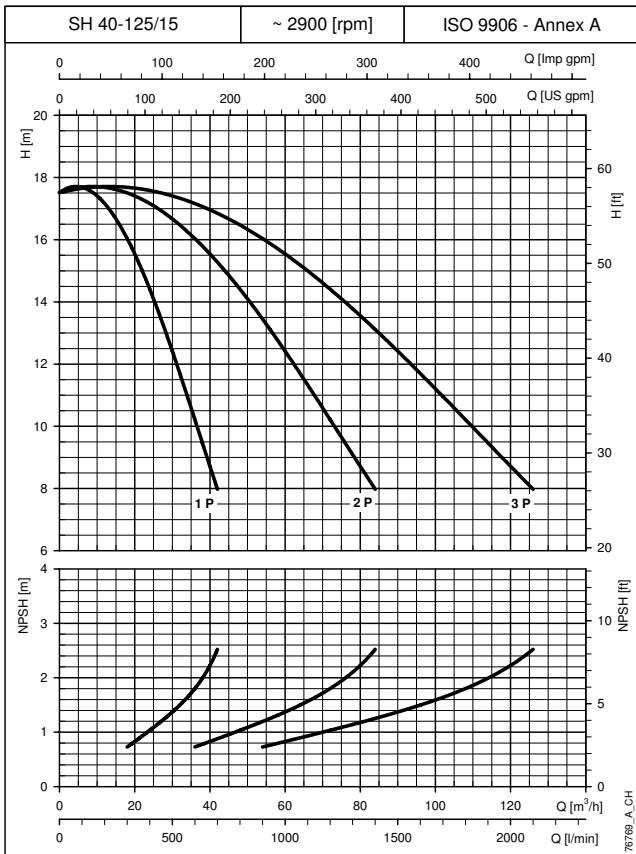
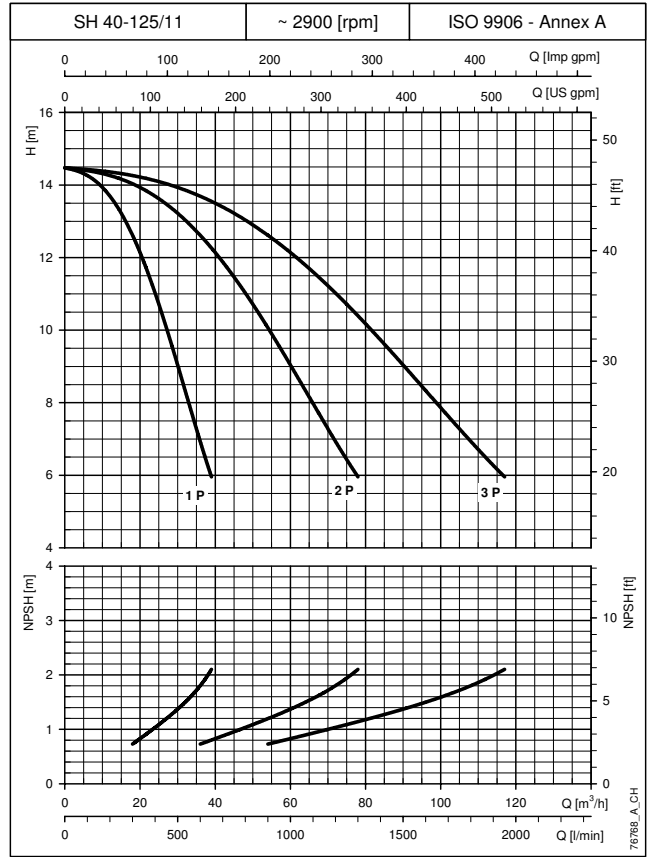
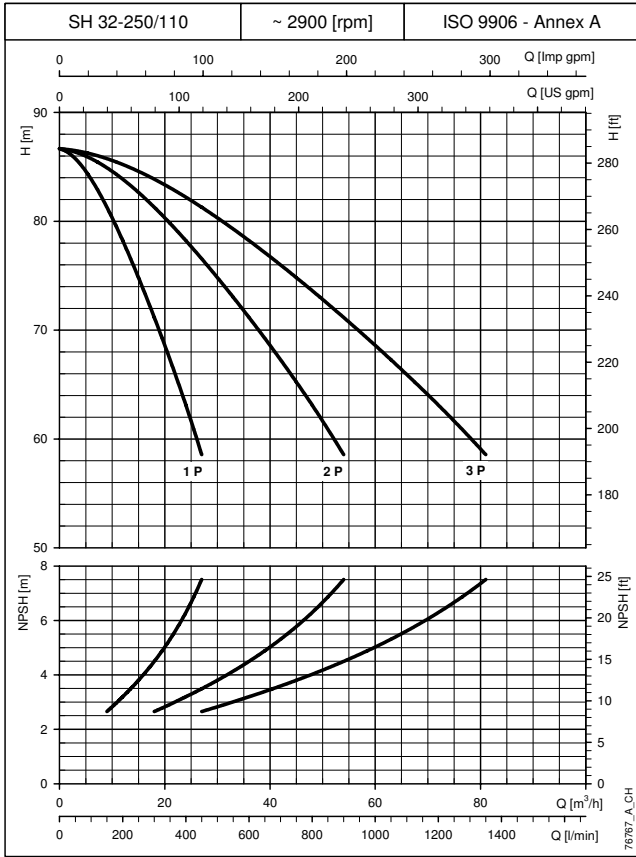

The performance curves do not take into account flow resistance in the valves and piping.
 The curves show the performance with one, two and three pumps running.
 These performances are valid for liquids with density $\rho = 1.0 \text{ Kg/dm}^3$ and kinematic viscosity $\nu = 1 \text{ mm}^2/\text{s}$.
 The declared NPSH values are laboratory values: for practical use we recommend increasing these values by 0.5 m.

**BOOSTER SETS, GS.../SH SERIES
OPERATING CHARACTERISTICS AT 50 Hz (SERVICE PUMP)**

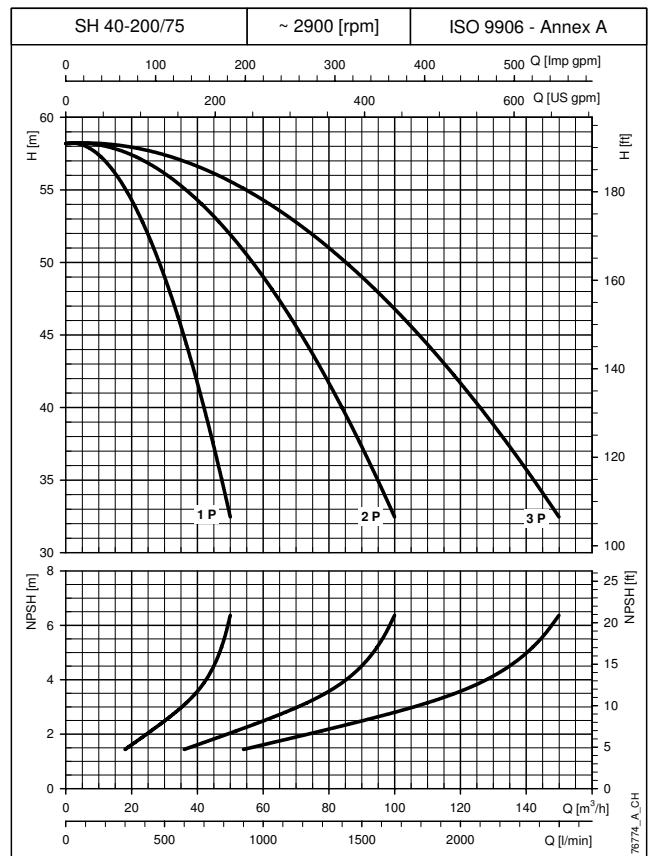
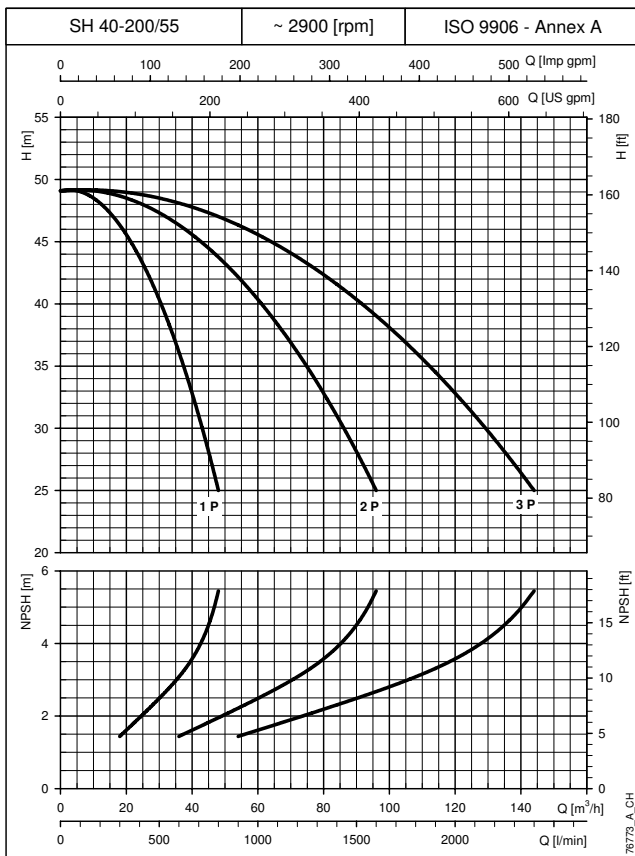
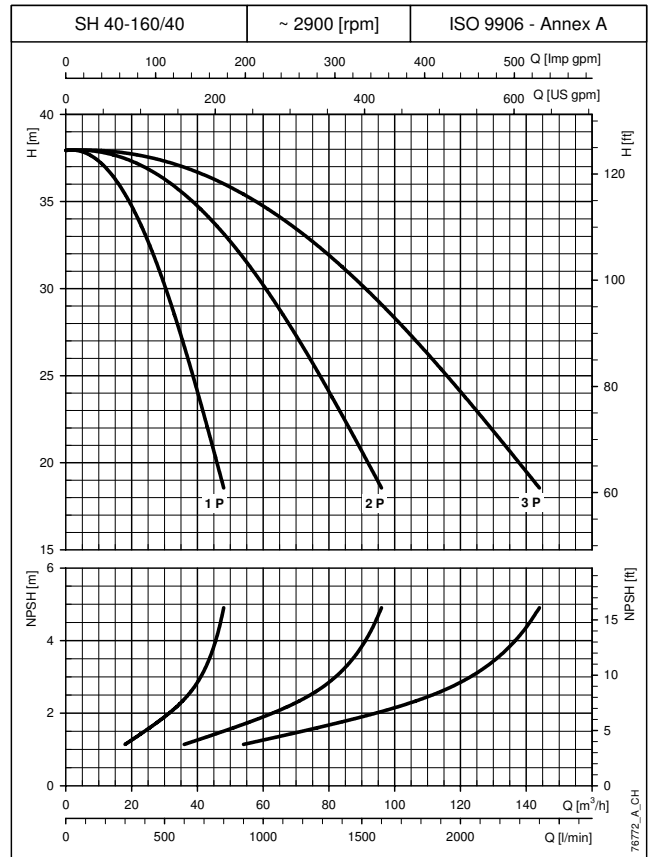
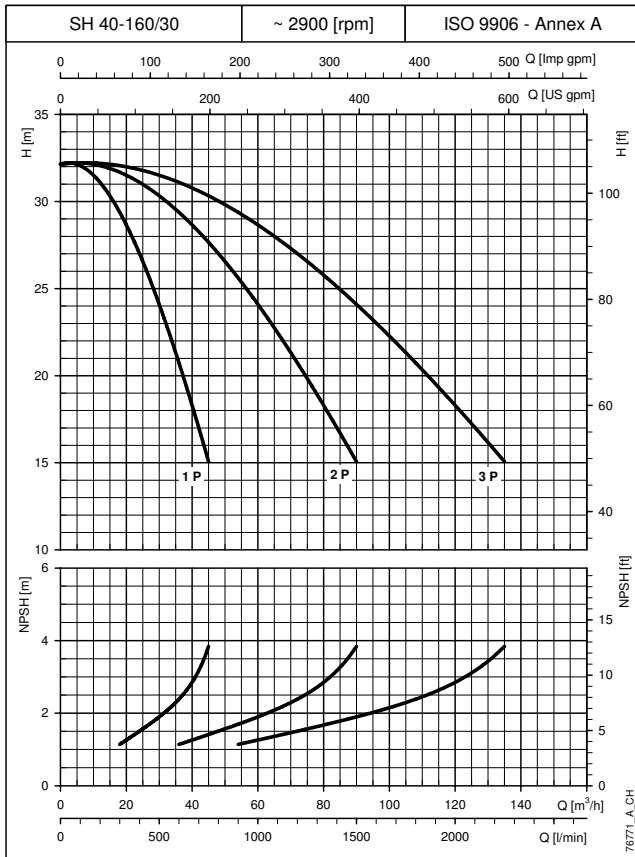

The performance curves do not take into account flow resistance in the valves and piping.
The curves show the performance with one, two and three pumps running.
These performances are valid for liquids with density $\rho = 1.0 \text{ Kg/dm}^3$ and kinematic viscosity $\nu = 1 \text{ mm}^2/\text{s}$.
The declared NPSH values are laboratory values: for practical use we recommend increasing these values by 0.5 m.

GS.../SH

**BOOSTER SETS, GS.../SH SERIES
OPERATING CHARACTERISTICS AT 50 Hz (SERVICE PUMP)**

GS.../SH

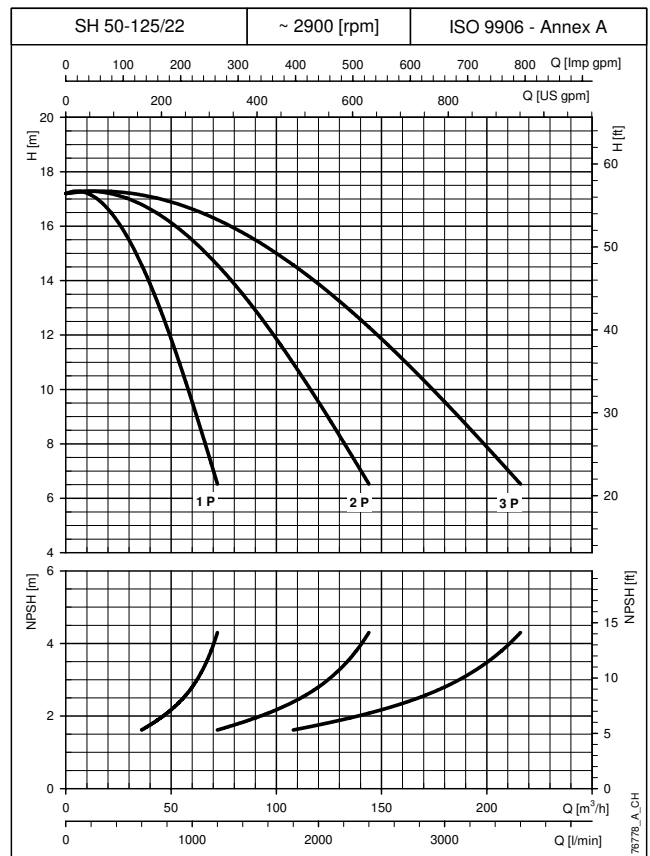
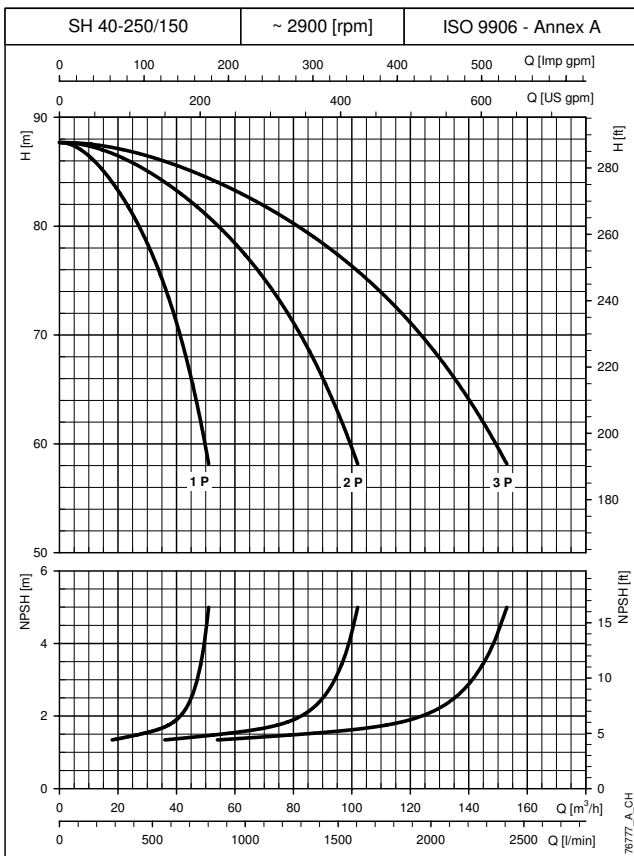
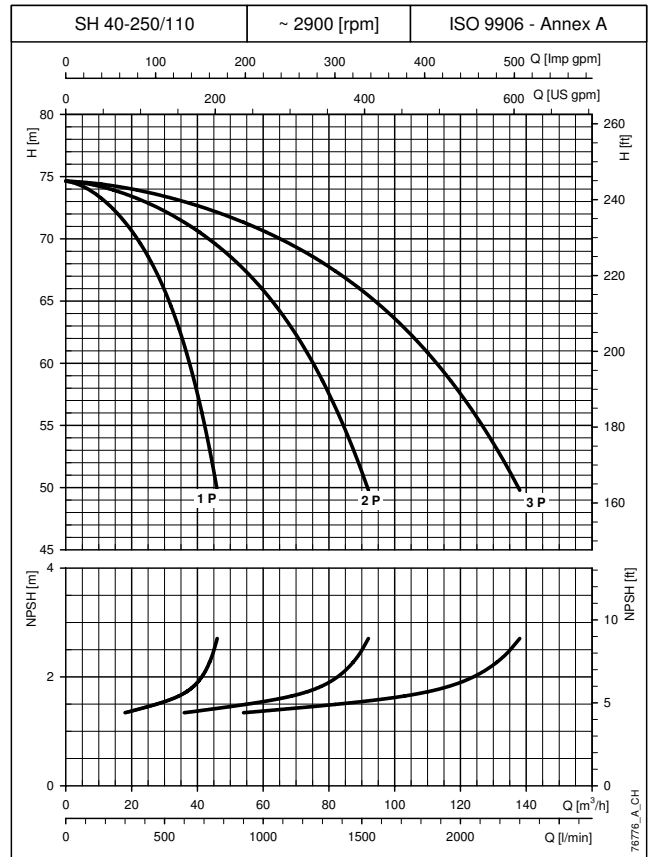
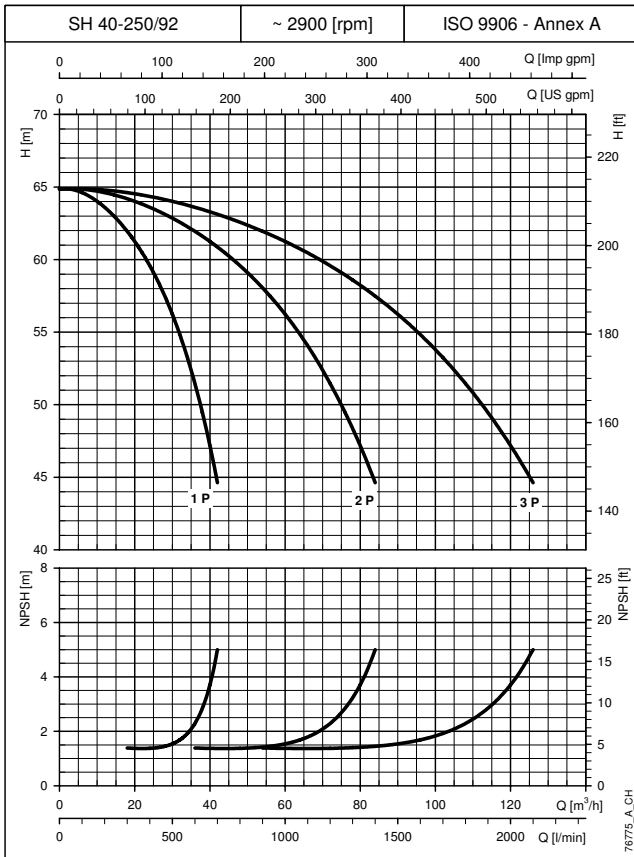

The performance curves do not take into account flow resistance in the valves and piping.
 The curves show the performance with one, two and three pumps running.
 These performances are valid for liquids with density $\rho = 1.0 \text{ Kg/dm}^3$ and kinematic viscosity $\nu = 1 \text{ mm}^2/\text{s}$.
 The declared NPSH values are laboratory values: for practical use we recommend increasing these values by 0.5 m.

**BOOSTER SETS, GS.../SH SERIES
OPERATING CHARACTERISTICS AT 50 Hz (SERVICE PUMP)**

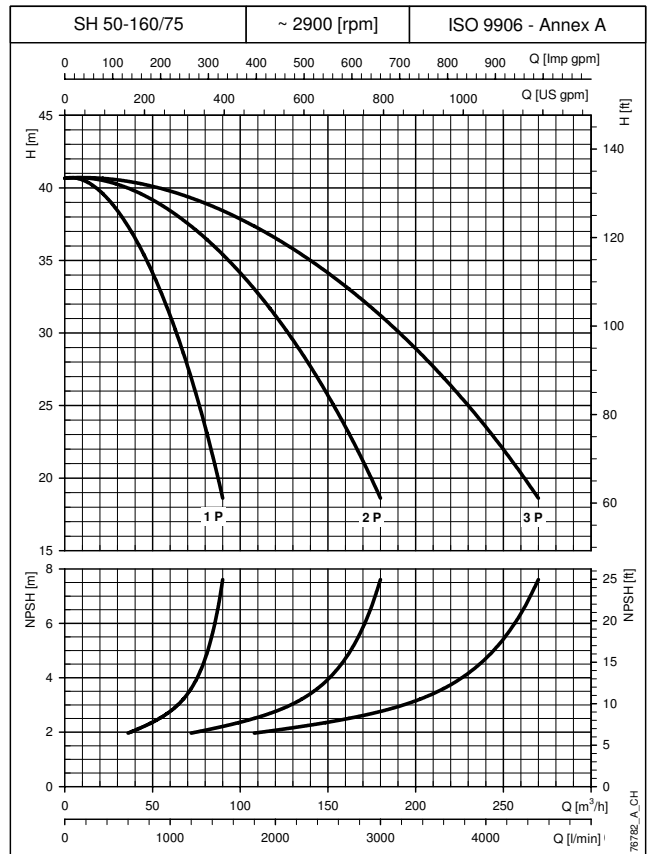
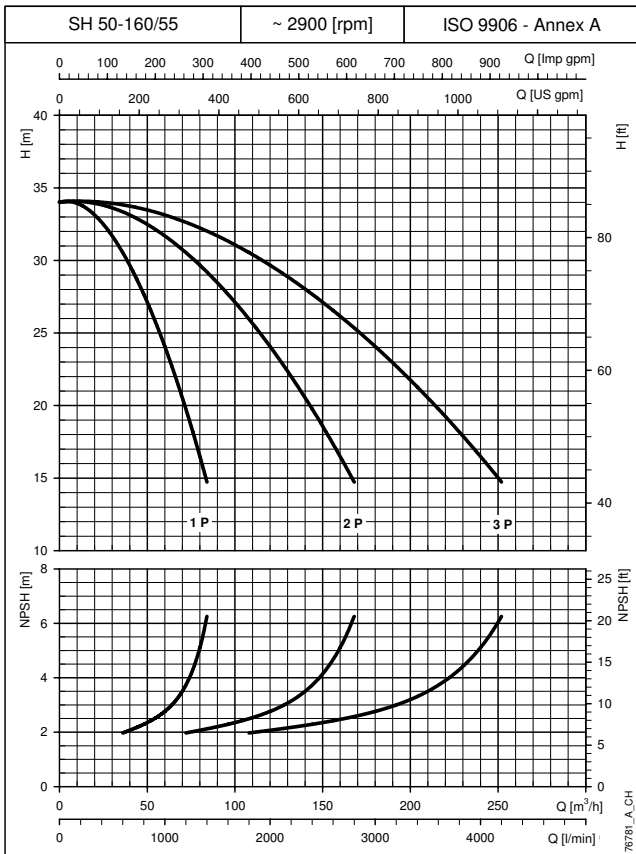
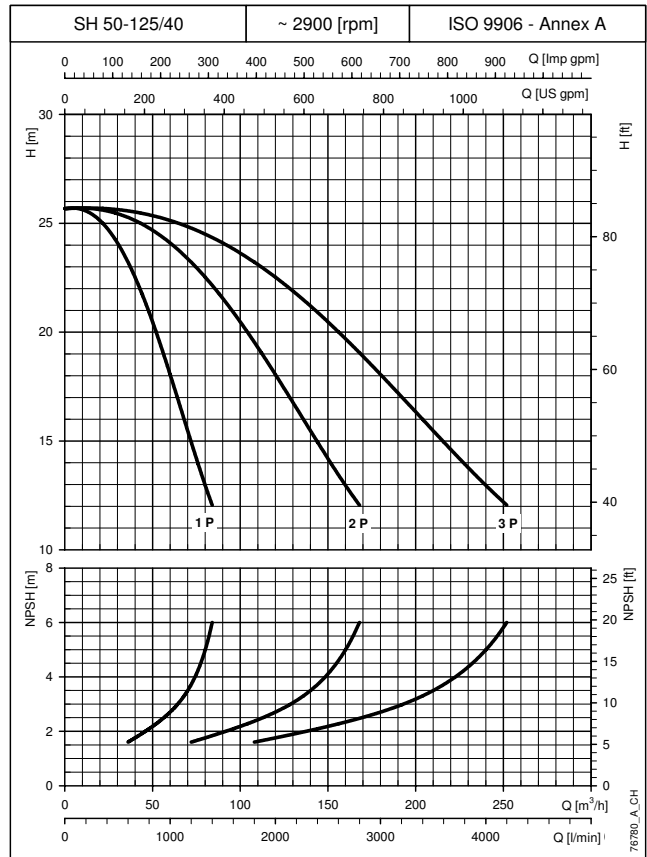
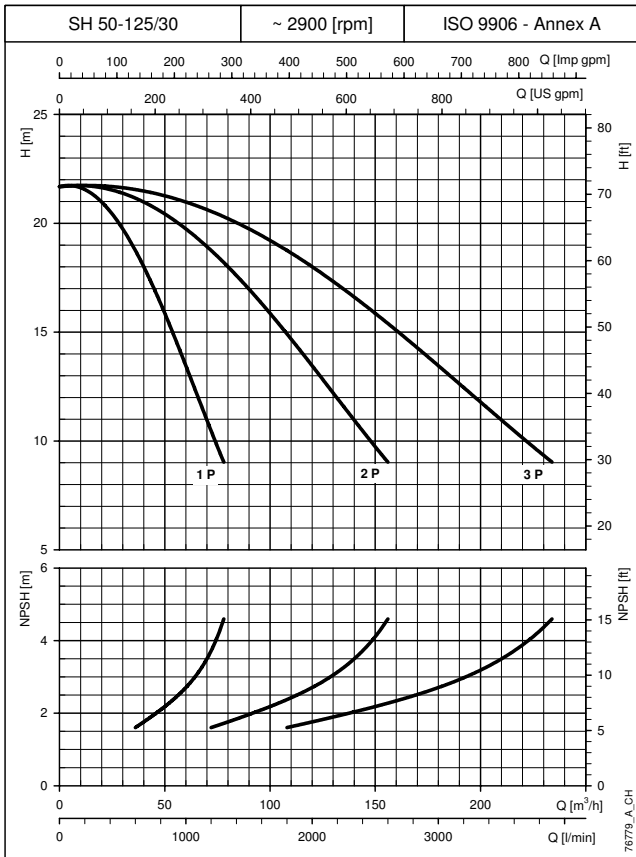

The performance curves do not take into account flow resistance in the valves and piping.
 The curves show the performance with one, two and three pumps running.
 These performances are valid for liquids with density $\rho = 1.0 \text{ Kg/dm}^3$ and kinematic viscosity $\nu = 1 \text{ mm}^2/\text{s}$.
 The declared NPSH values are laboratory values: for practical use we recommend increasing these values by 0.5 m.

GS.../SH

BOOSTER SETS, GS.../SH SERIES OPERATING CHARACTERISTICS AT 50 Hz (SERVICE PUMP)

GS.../SH

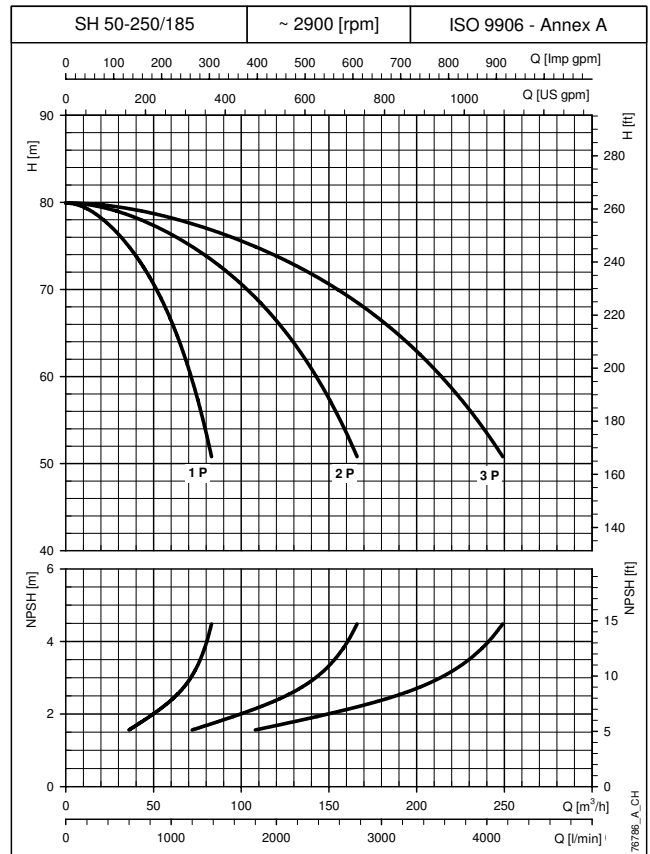
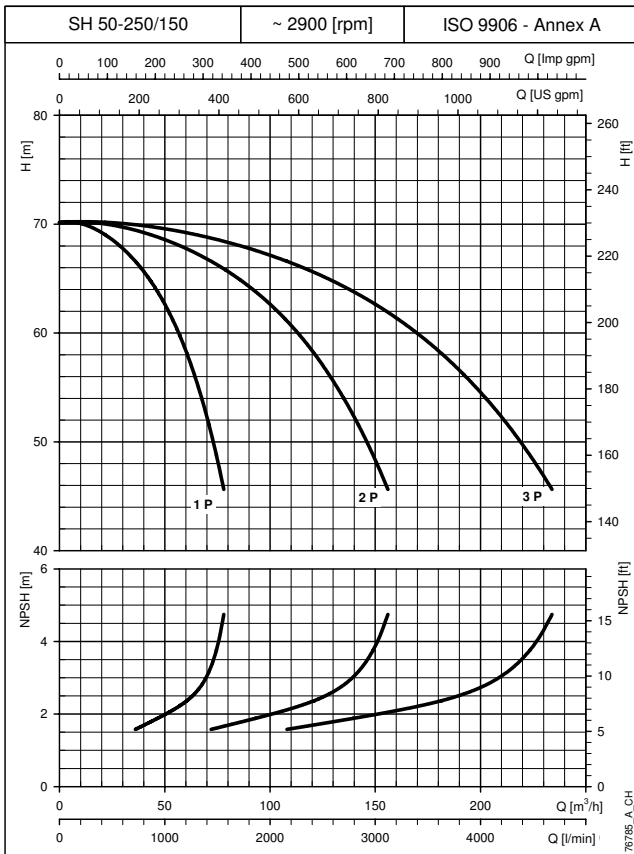
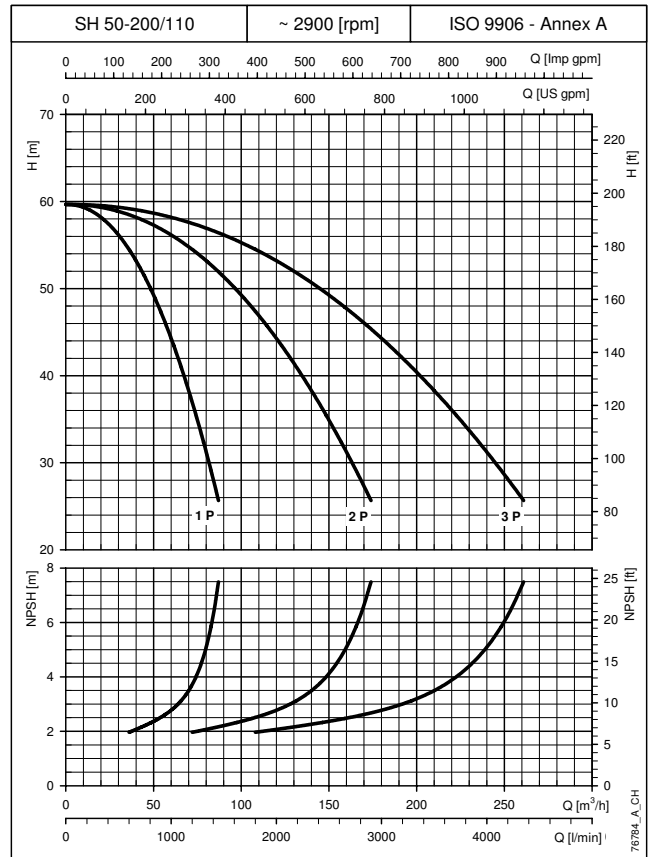
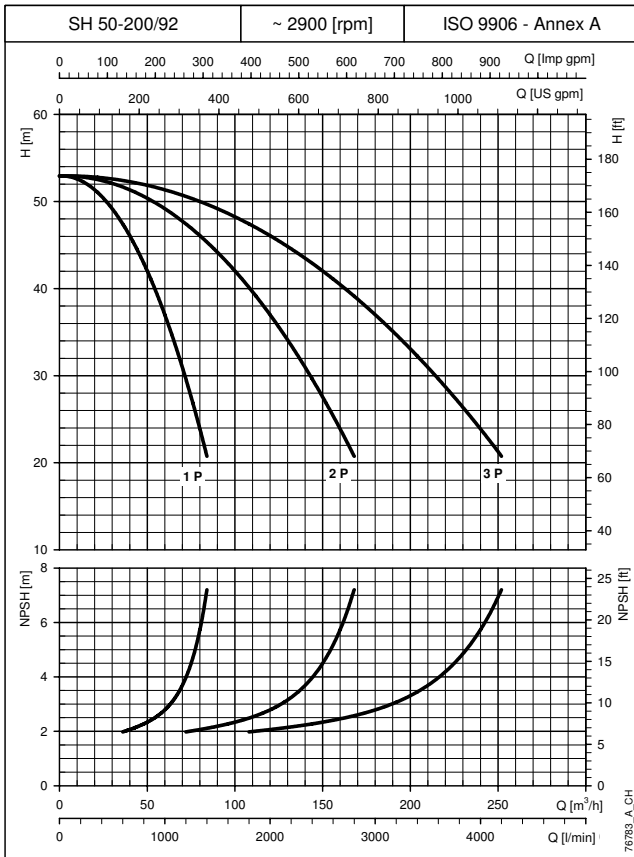

The performance curves do not take into account flow resistance in the valves and piping.
 The curves show the performance with one, two and three pumps running.
 These performances are valid for liquids with density $\rho = 1.0 \text{ Kg/dm}^3$ and kinematic viscosity $\nu = 1 \text{ mm}^2/\text{s}$.
 The declared NPSH values are laboratory values: for practical use we recommend increasing these values by 0.5 m.

**BOOSTER SETS, GS.../SH SERIES
OPERATING CHARACTERISTICS AT 50 Hz (SERVICE PUMP)**

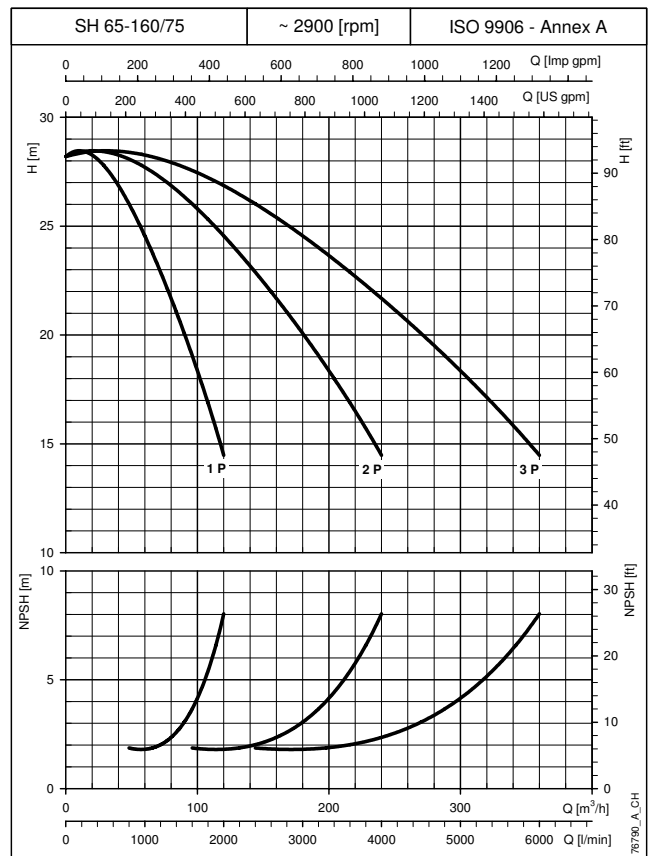
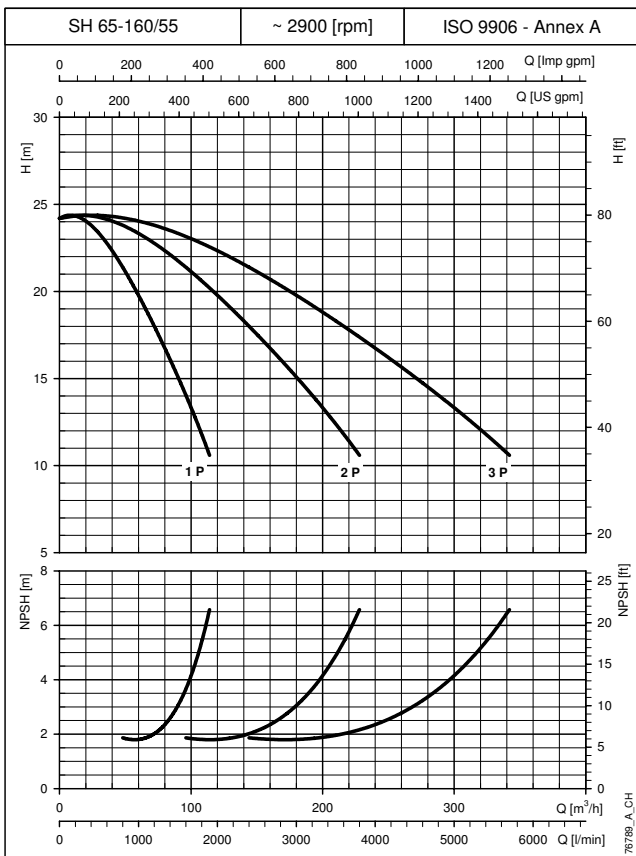
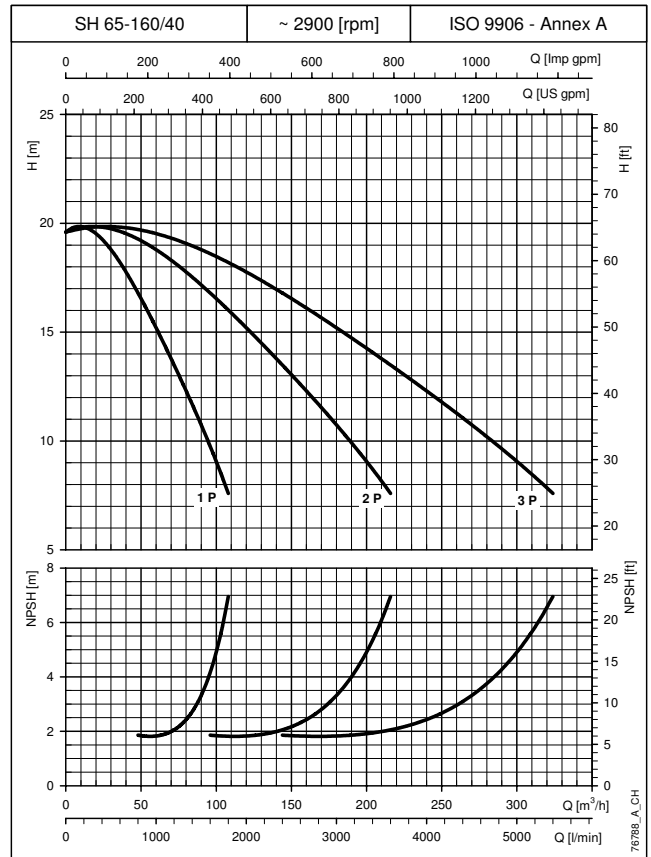
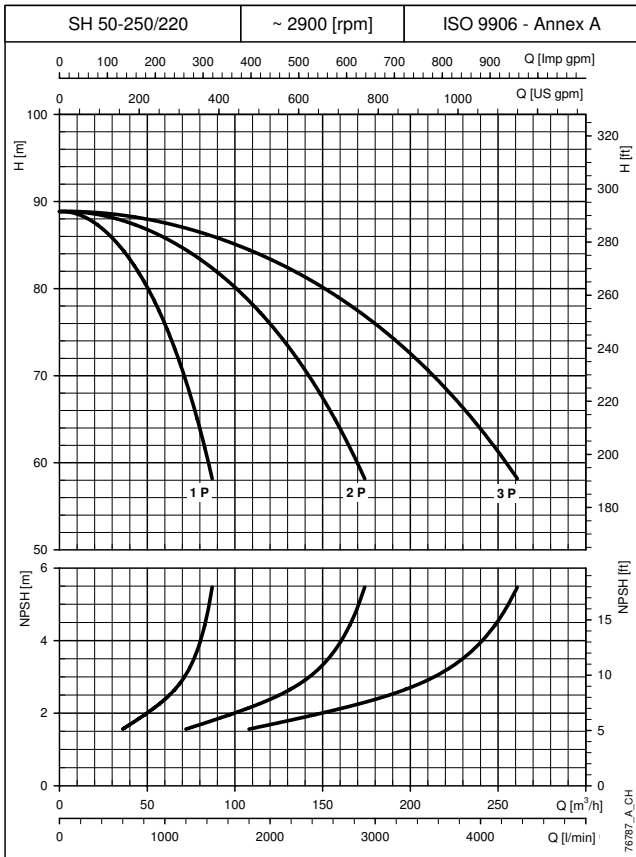

The performance curves do not take into account flow resistance in the valves and piping.
The curves show the performance with one, two and three pumps running.
These performances are valid for liquids with density $\rho = 1.0 \text{ Kg/dm}^3$ and kinematic viscosity $\nu = 1 \text{ mm}^2/\text{s}$.
The declared NPSH values are laboratory values; for practical use we recommend increasing these values by 0.5 m.

GS.../SH

**BOOSTER SETS, GS.../SH SERIES
OPERATING CHARACTERISTICS AT 50 Hz (SERVICE PUMP)**

GS.../SH

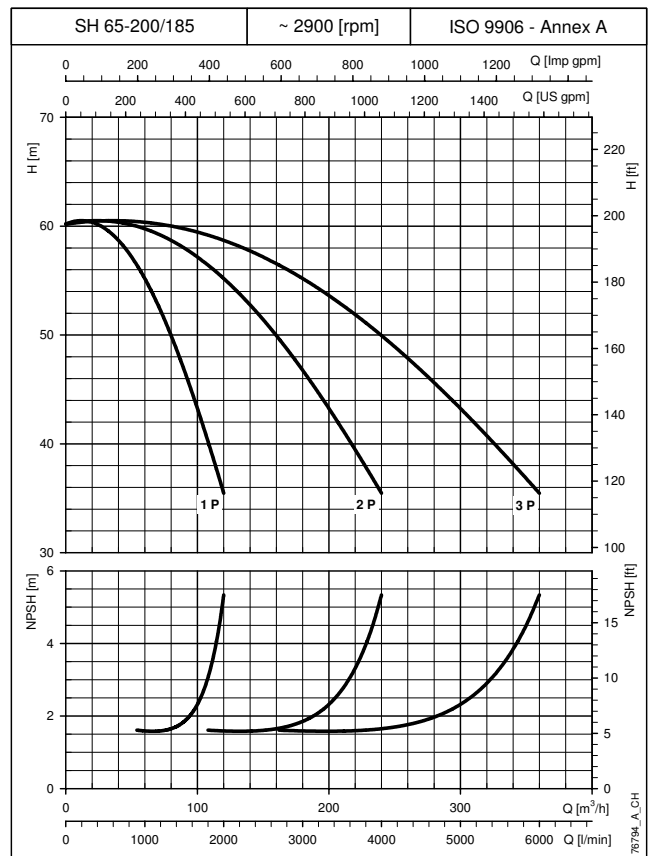
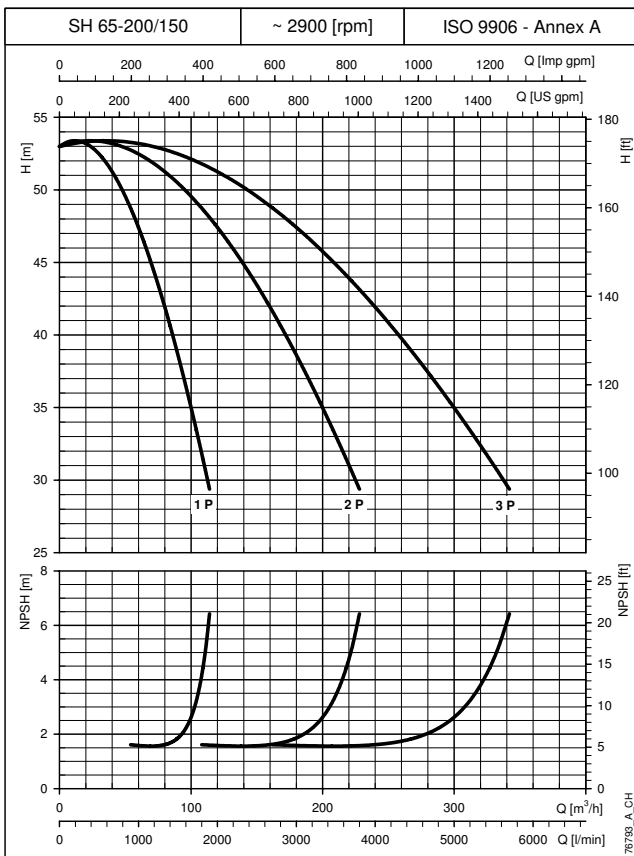
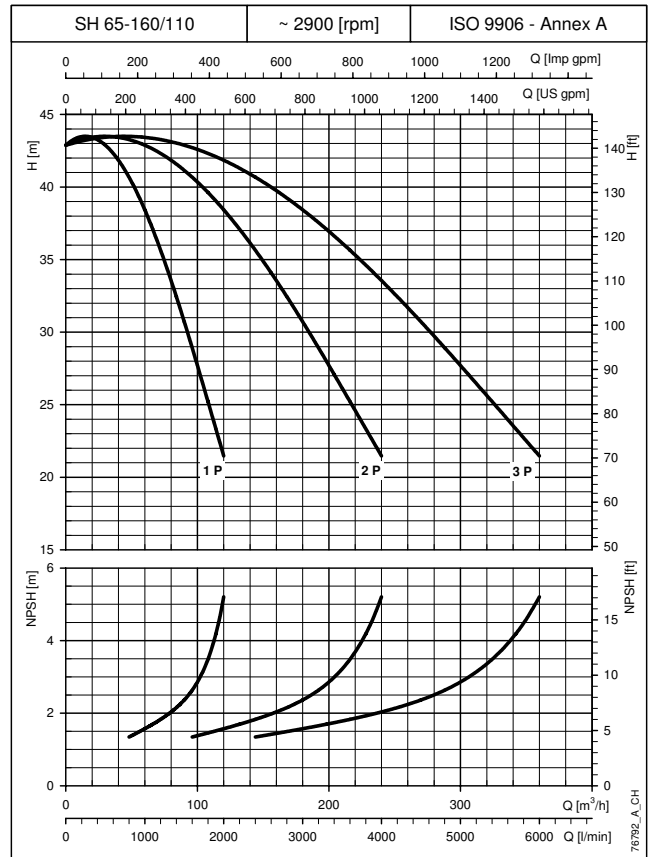
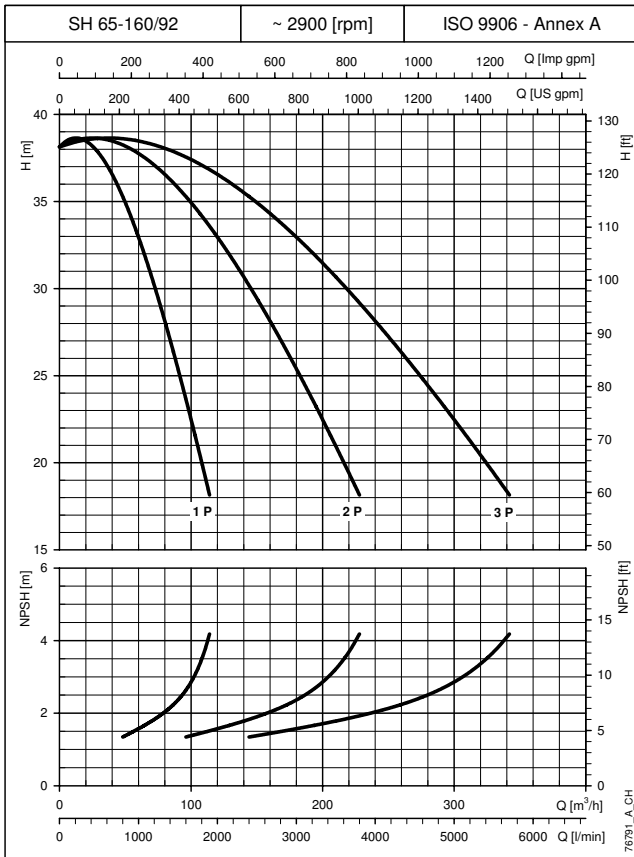

The performance curves do not take into account flow resistance in the valves and piping.
The curves show the performance with one, two and three pumps running.
These performances are valid for liquids with density $\rho = 1.0 \text{ Kg/dm}^3$ and kinematic viscosity $\nu = 1 \text{ mm}^2/\text{s}$.
The declared NPSH values are laboratory values: for practical use we recommend increasing these values by 0.5 m.

**BOOSTER SETS, GS.../SH SERIES
OPERATING CHARACTERISTICS AT 50 Hz (SERVICE PUMP)**

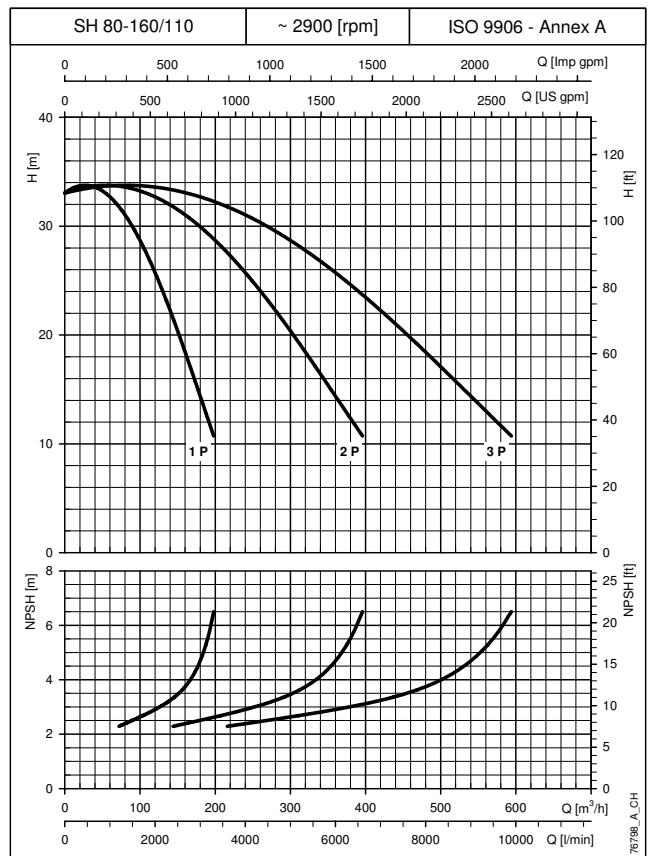
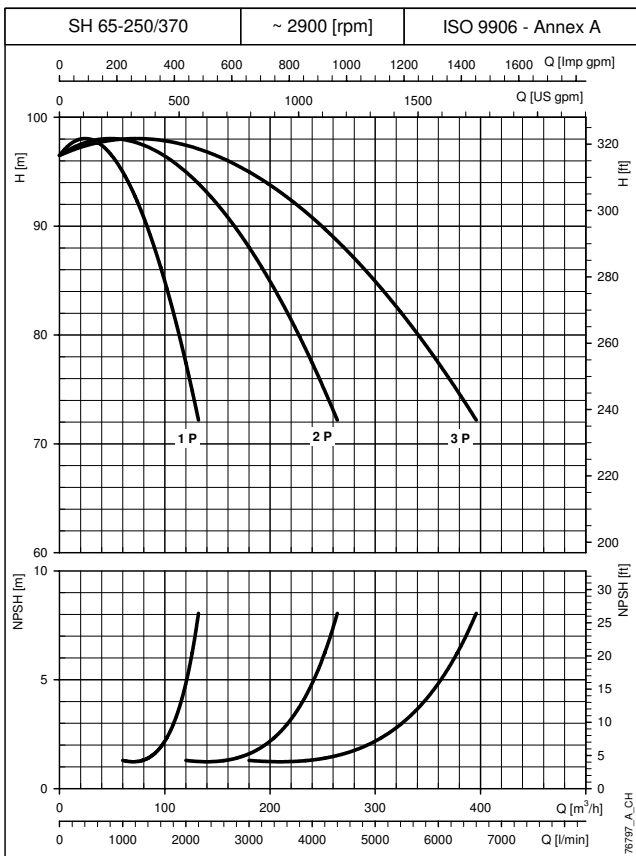
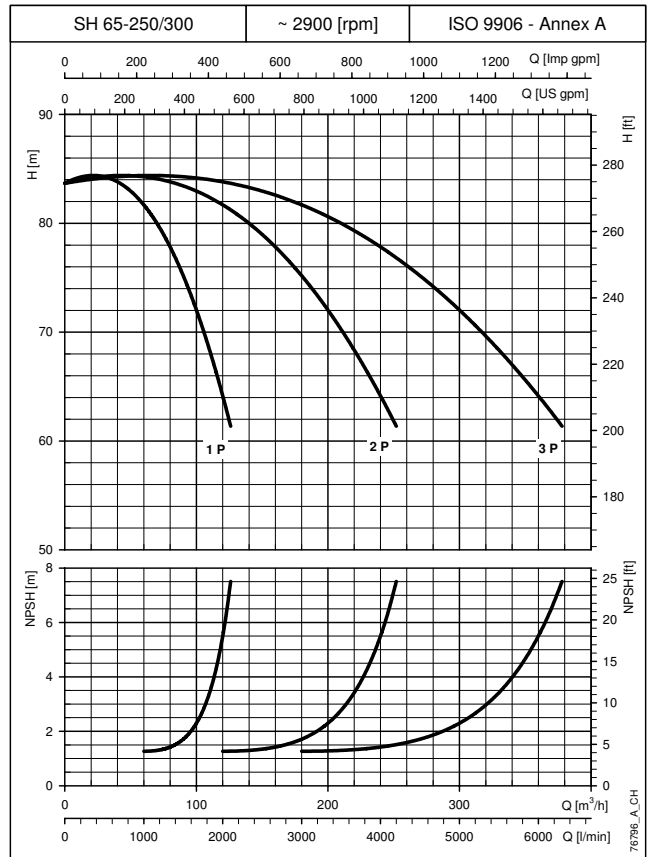
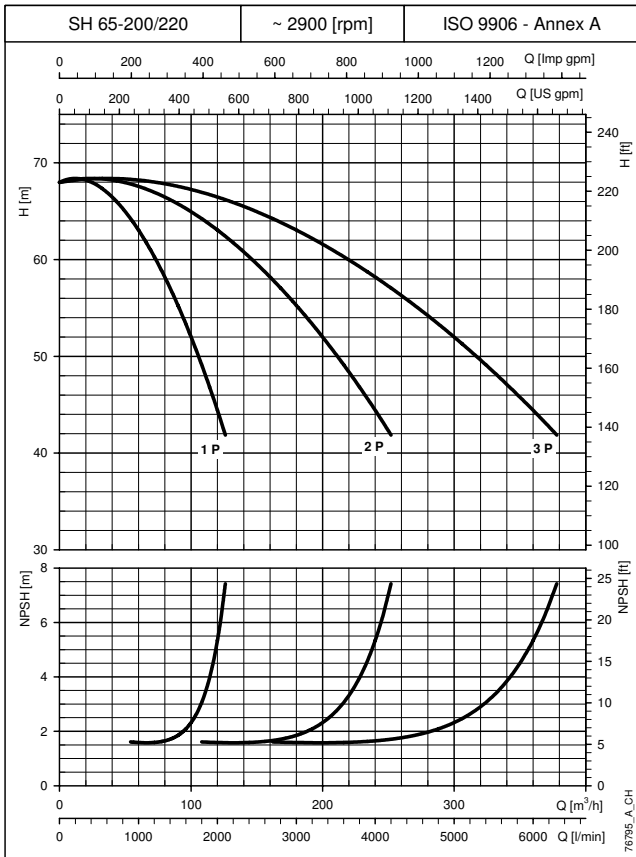

The performance curves do not take into account flow resistance in the valves and piping.
 The curves show the performance with one, two and three pumps running.
 These performances are valid for liquids with density $\rho = 1.0 \text{ Kg/dm}^3$ and kinematic viscosity $\nu = 1 \text{ mm}^2/\text{s}$.
 The declared NPSH values are laboratory values: for practical use we recommend increasing these values by 0.5 m.

GS.../SH

**BOOSTER SETS, GS.../SH SERIES
OPERATING CHARACTERISTICS AT 50 Hz (SERVICE PUMP)**

GS.../SH

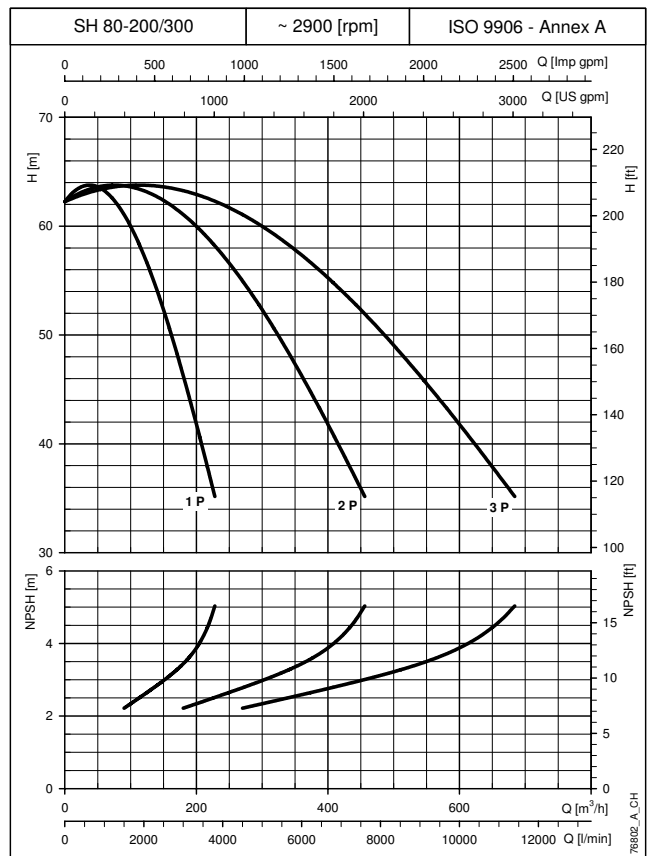
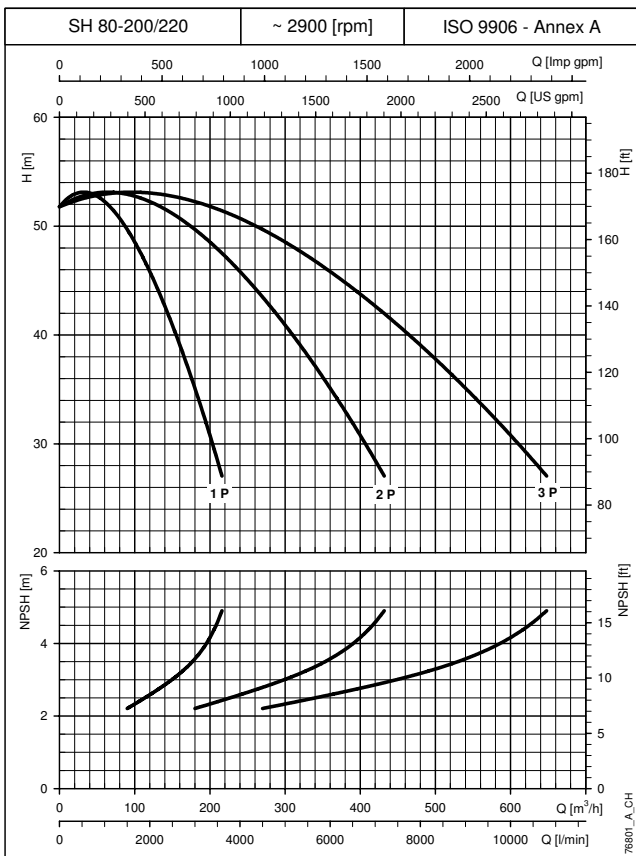
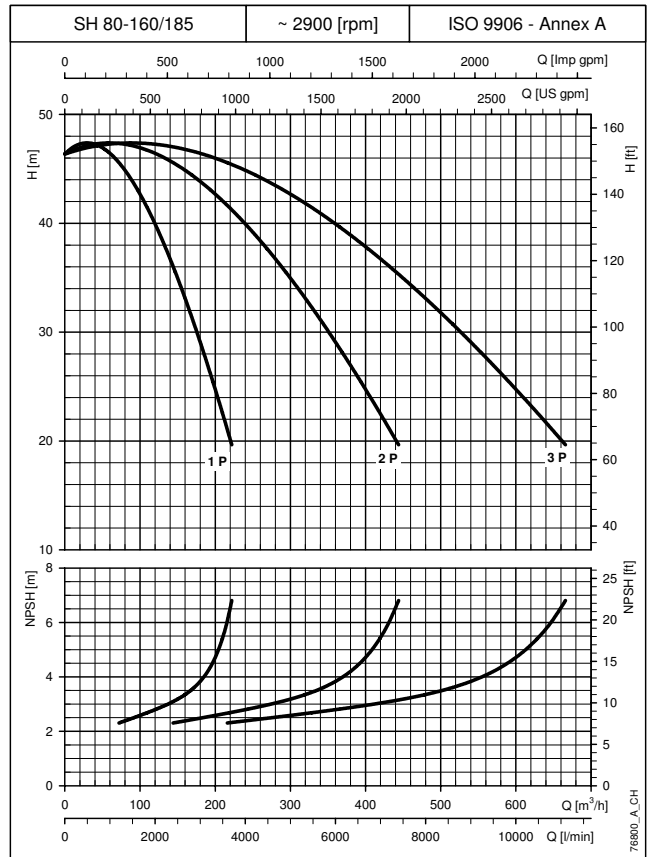
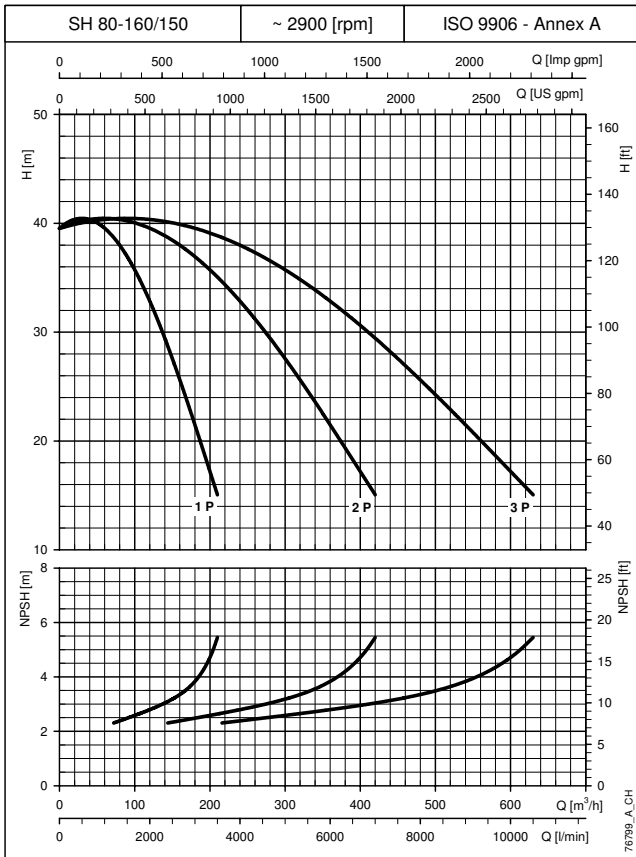

The performance curves do not take into account flow resistance in the valves and piping.
 The curves show the performance with one, two and three pumps running.
 These performances are valid for liquids with density $\rho = 1.0 \text{ Kg/dm}^3$ and kinematic viscosity $\nu = 1 \text{ mm}^2/\text{s}$.
 The declared NPSH values are laboratory values: for practical use we recommend increasing these values by 0.5 m.

**BOOSTER SETS, GS.../SH SERIES
OPERATING CHARACTERISTICS AT 50 Hz (SERVICE PUMP)**

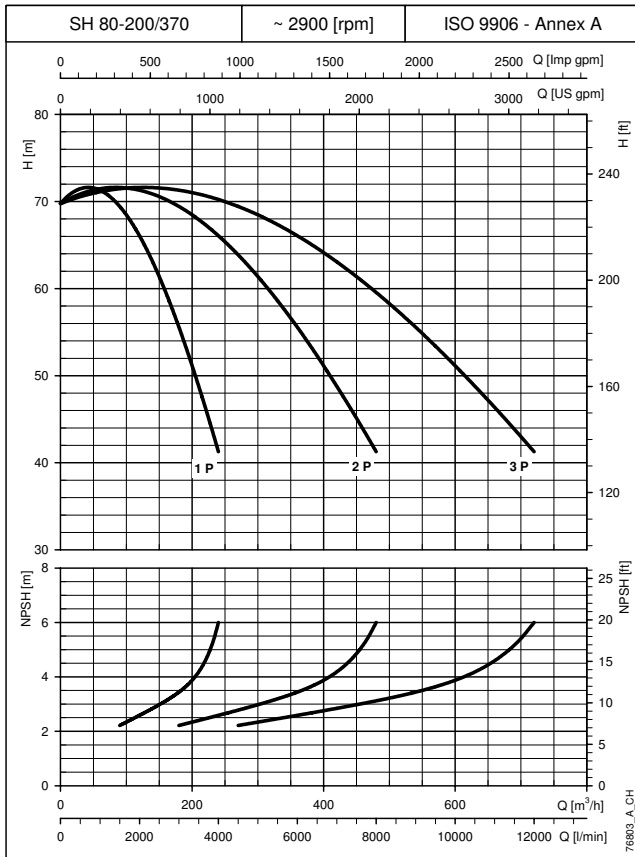

The performance curves do not take into account flow resistance in the valves and piping.
 The curves show the performance with one, two and three pumps running.
 These performances are valid for liquids with density $\rho = 1.0 \text{ Kg/dm}^3$ and kinematic viscosity $\nu = 1 \text{ mm}^2/\text{s}$.
 The declared NPSH values are laboratory values: for practical use we recommend increasing these values by 0.5 m.

GS.../SH

BOOSTER SETS, GS.../SH SERIES
H_c PRESSURE DROP CURVE

GS.../SH

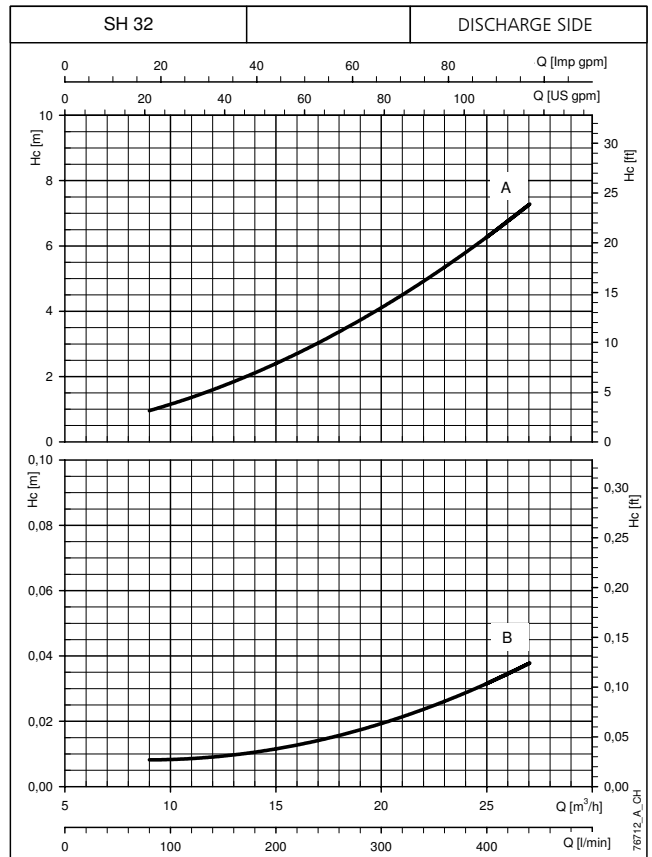
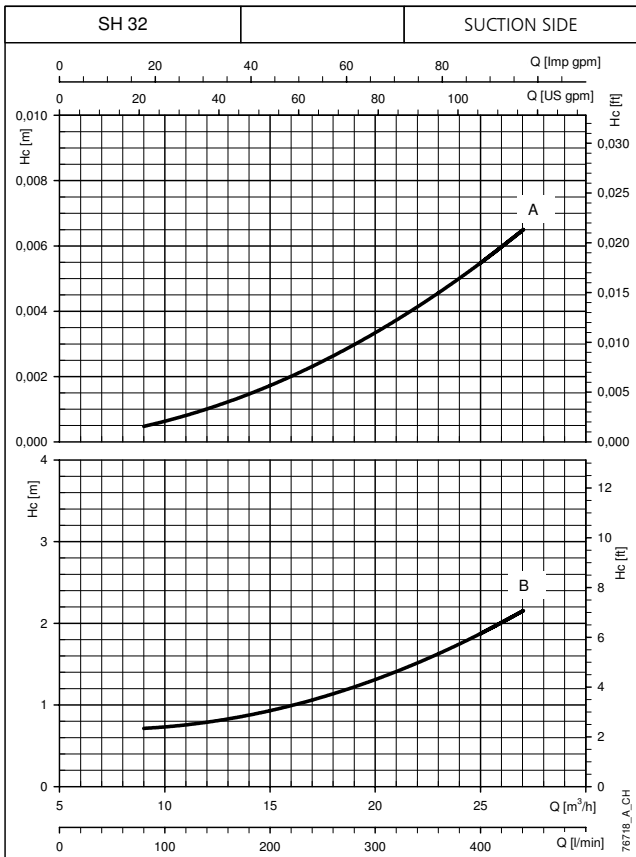
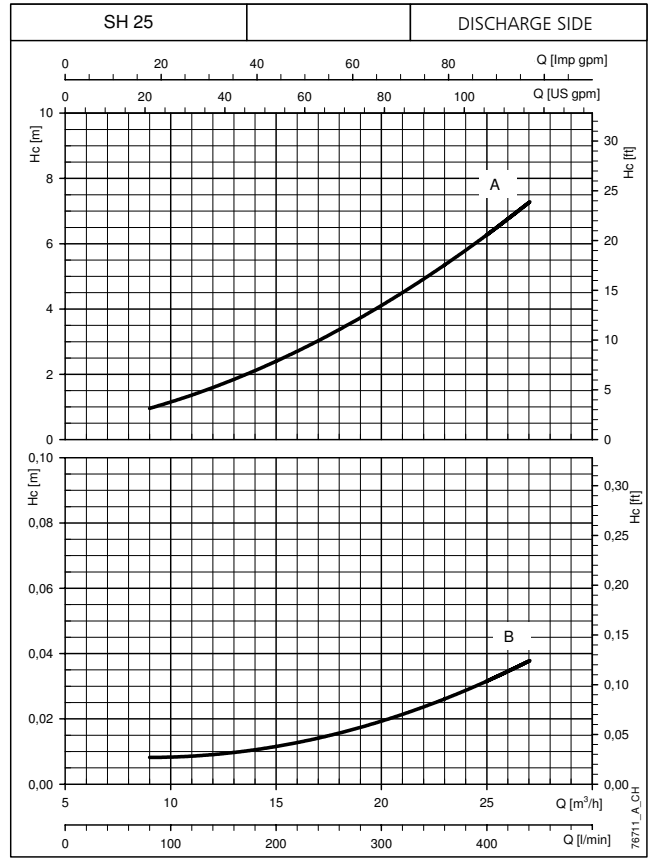
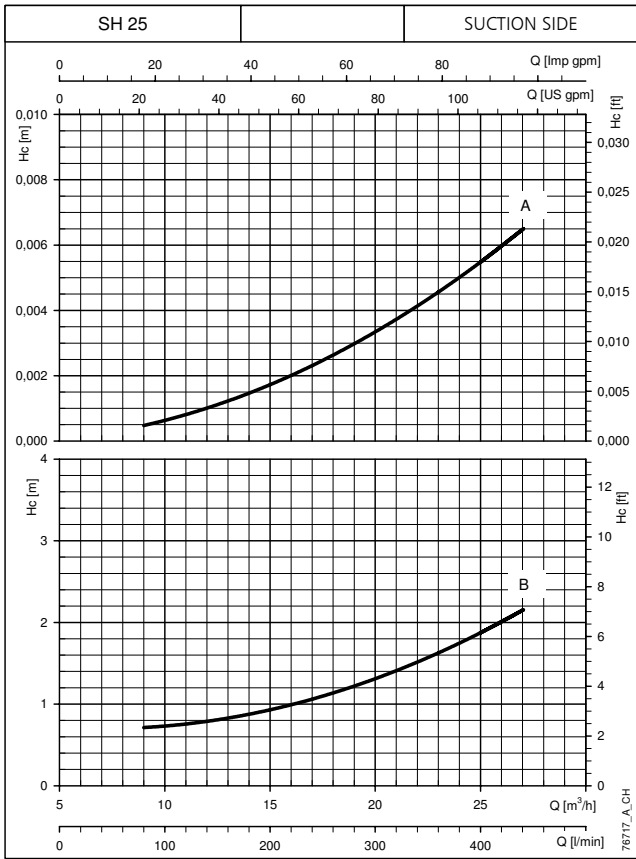

The declared curves are valid for liquids with density $\rho = 1.0 \text{ Kg/dm}^3$ and kinematic viscosity $\nu = 1 \text{ mm}^2/\text{sec}$.
 Hc (A): Pressure drop curve with check valve installed on the delivery side of the pump.
 Hc (B): Pressure drop curve with check valve installed on the suction side of the pump.
 The pressure drops do not consider the pressure drops distributed in the manifold.

BOOSTER SETS, GS.../SH SERIES
H_c PRESSURE DROP CURVE

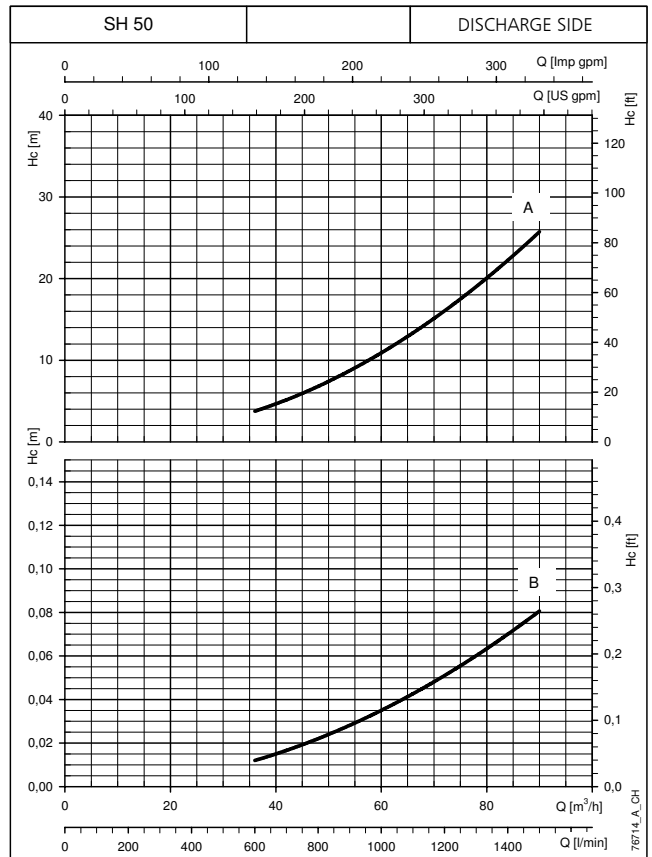
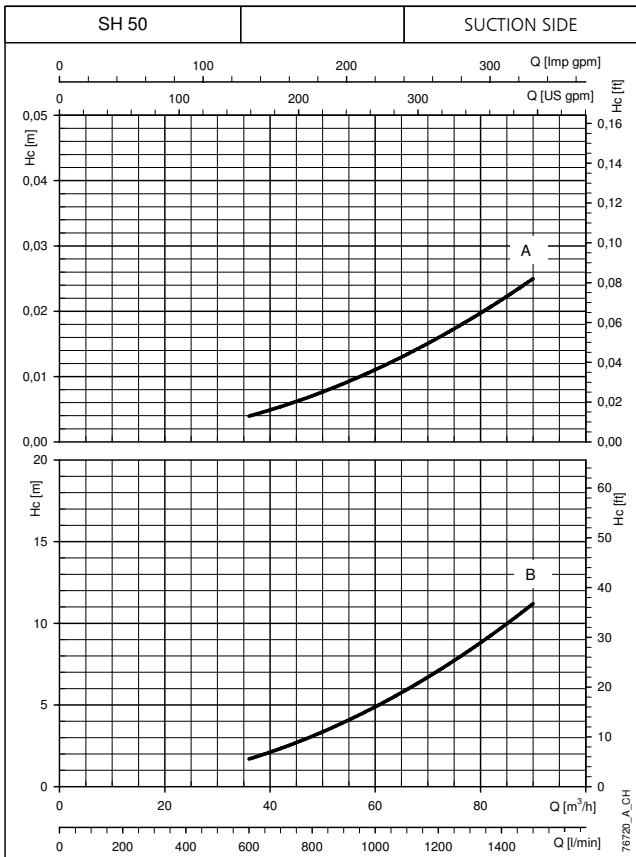
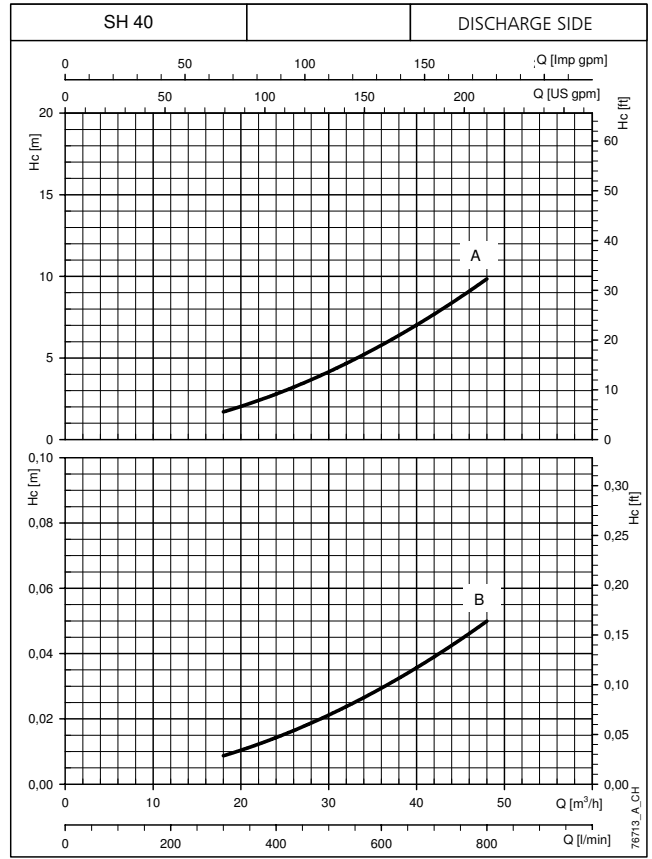
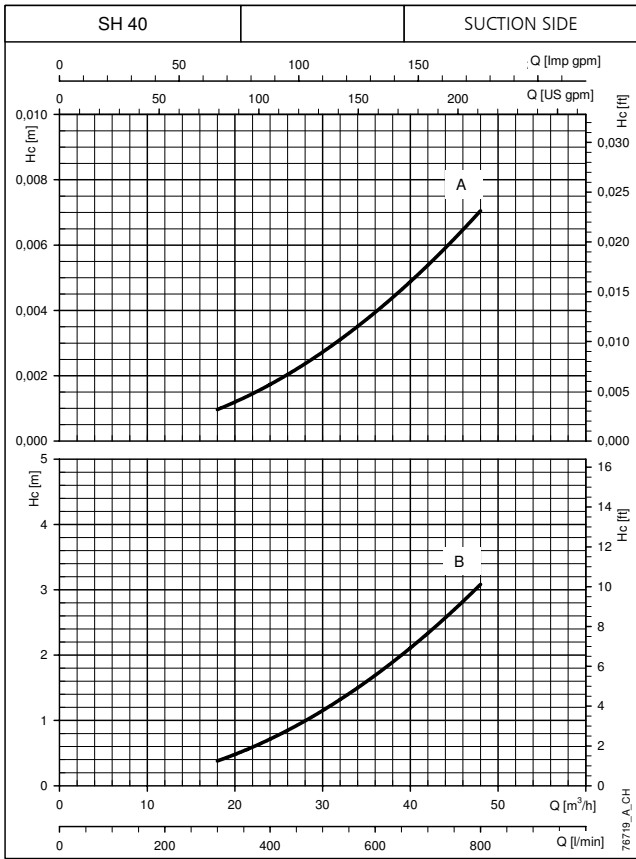

The declared curves are valid for liquids with density $\rho = 1.0 \text{ Kg/dm}^3$ and kinematic viscosity $\nu = 1 \text{ mm}^2/\text{sec}$.
 H_c (A): Pressure drop curve with check valve installed on the delivery side of the pump.
 H_c (B): Pressure drop curve with check valve installed on the suction side of the pump.
 The pressure drops do not consider the pressure drops distributed in the manifold.

GS.../SH

BOOSTER SETS, GS.../SH SERIES
H_c PRESSURE DROP CURVE

GS.../SH

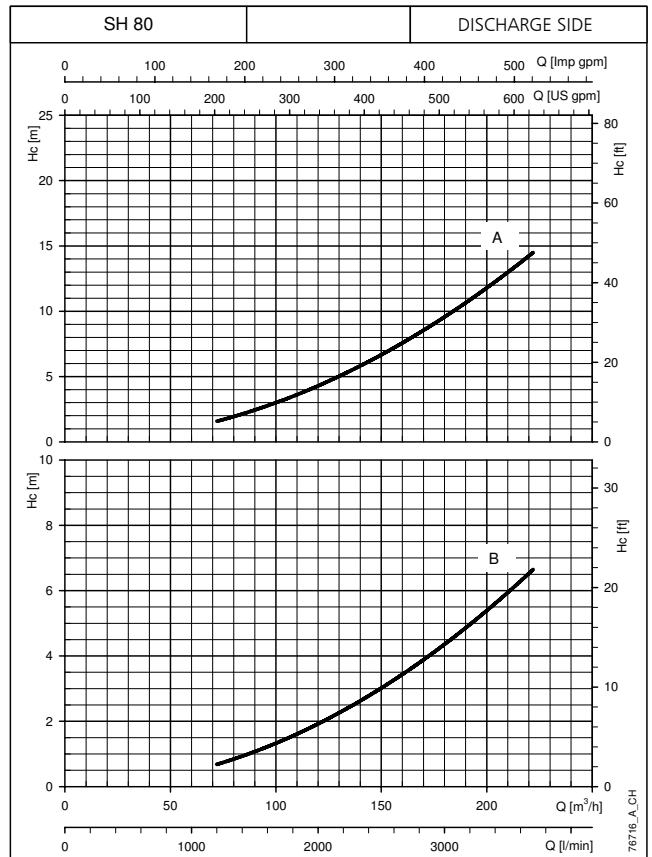
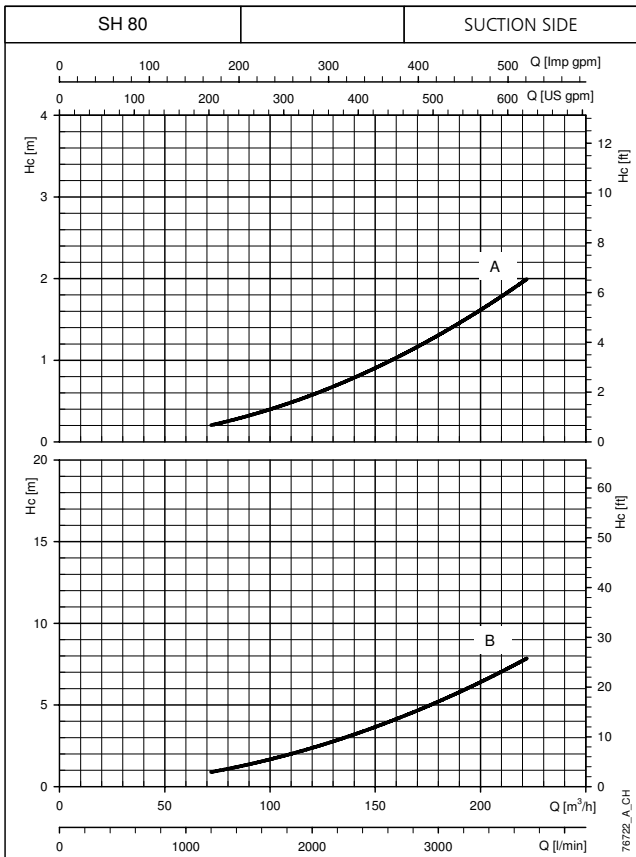
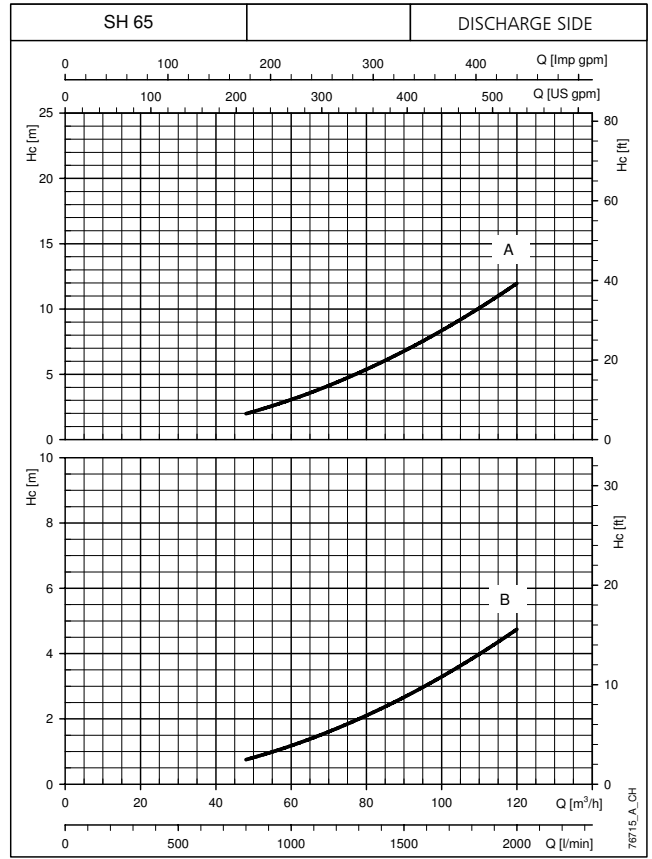
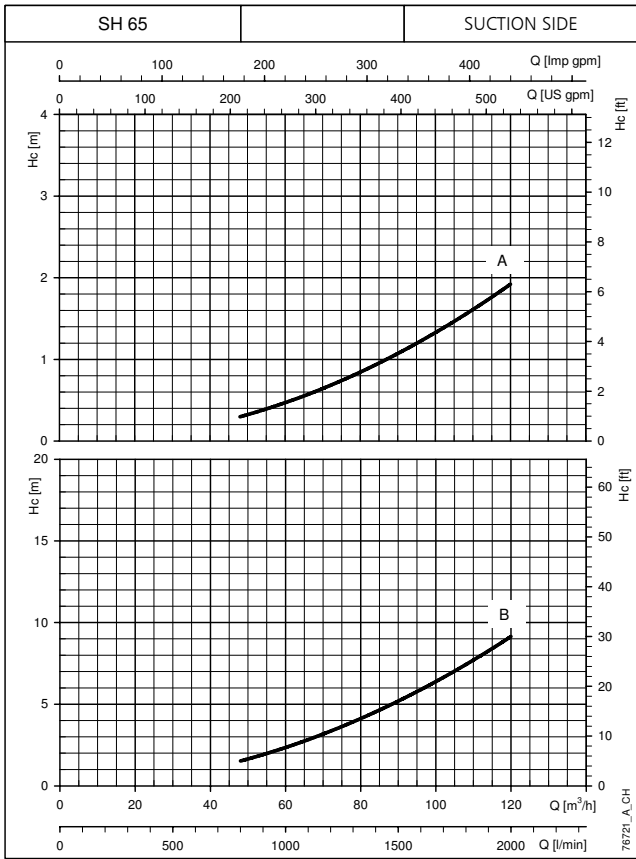

The declared curves are valid for liquids with density $\rho = 1.0 \text{ Kg/dm}^3$ and kinematic viscosity $\nu = 1 \text{ mm}^2/\text{sec}$.
 Hc (A): Pressure drop curve with check valve installed on the delivery side of the pump.
 Hc (B): Pressure drop curve with check valve installed on the suction side of the pump.
 The pressure drops do not consider the pressure drops distributed in the manifold.

ACCESSORIES

DIAPHRAGM TANKS

The booster sets are ready for installation, directly on the manifold, of 24-litre diaphragm tanks, one for each pump. The sets are also equipped with caps to close off the unused couplings. Larger tanks can also be connected to the unused end of the discharge manifold. For proper sizing of the tank please refer to the technical appendix.

Kits featuring the following accessories are **available on request**:

- diaphragm tank;
- on-off ball valve;
- operating instructions;
- packaging.

DIAPHRAGM TANK KIT

Volume Litres	PN bar	DIMENSIONS (mm)			Materials		
		ø A	B	Valve	Diaphragm	Vessel	Valve
8	8	205	390	1" FF	EPDM	Painted steel	Nickel-plated brass
24	8	270	555	1" FF	EPDM	Painted steel	Nickel-plated brass
24	10	270	555	1" FF	EPDM	Painted steel	Nickel-plated brass
24	16	270	555	1" FF	EPDM	Painted steel	Nickel-plated brass
24	10	270	575	1" FF	Butyl	Stainless steel	AISI 316 Stainless steel

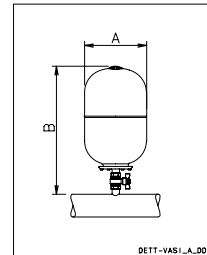

gcom-vmb_en_b_td

DETT-VAS1_A_00

COUNTERFLANGE KIT

Manifolds up to 3" in diameter are usually supplied with threaded couplings and caps on unused end.

Counterflange coupling kits made of zinc-plated or stainless steel are available on request.

The counterflange kits are equipped with:

- threaded flange.
- gasket and bolts/screws.
- threaded counterflange (weld-on type for 3" diameter).

THREADED COUNTERFLANGES

KIT TYPE	DN	ø C	DIMENSIONS (mm)				HOLES		PN
			ø A	B	ø D	H	ø F	N°	
2"	50	Rp 2	125	16	165	24	18	4	25
2" 1/2	65	Rp 2 1/2	145	16	185	23	18	4	16
3"	80	Rp 3	160	17	200	27	18	8	16

Gcom-ctf-tonde-f-en_a_td

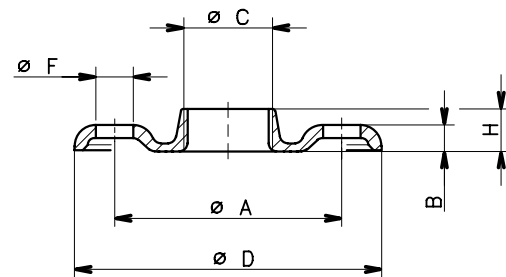

04430_B_DD

WELD-ON COUNTERFLANGES

KIT TYPE	DN	ø C	DIMENSIONS (mm)				HOLES		PN
			ø A	B	ø D	ø F	N°		
2"	50	61	125	19	165	18	4	16	
2"1/2	65	77	145	20	185	18	4	16	
3"	80	90	160	20	200	18	8	16	
4"	100	116	180	22	220	18	8	16	
5"	125	141,5	210	22	250	18	8	16	
6"	150	170,5	240	24	285	22	8	16	
8"	200	221,5	295	26	340	22	12	16	
10"	250	276,5	355	29	405	26	12	16	
12"	300	327,5	410	32	460	26	12	16	

Gcom-ctf-tonde-s-en_c_td

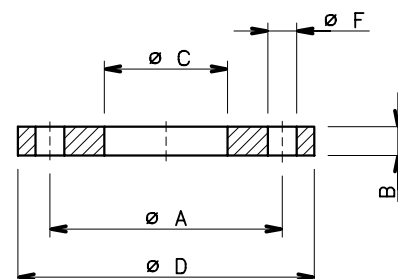

04431_A_DD

RUBBER EXPANSION JOINT KIT

The anti-vibrating joints or compensation joints can be used in order to absorb deformations, expansions, noises in the piping and to reduced ram blows. Moreover they can resist a high degree of empty that allows the absorption of negative expansions for depression.

Being of elastic material it can be become deformed and be dilated facilitating therefore the installation, that it becomes simpler and fast, also in which the piping they are not aligned. It does not need assembly joints.

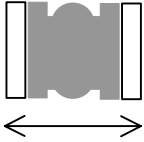
TABELLA 1 TABLE 1		L 	A-B-C-D non possono essere sommati			A-B-C-D can not be cumulative
GIUNTI ELASTICI RUBBER EXPANSION JOINT			A COMPRESSIONE COMPRESSION	B ESTENSIONE EXTENSION	C SPOSTAMENTO TRANSVERSE	D FLESSIONE ANGOLARE ANGULAR MOVEMENT
DN		mm	mm	mm	mm	(°)
32	1"1/4	95	8	4	8	15
40	1"1/2	95	8	4	8	15
50	2"	105	8	5	8	15
65	2"1/2	115	12	6	10	15
80	3"	130	12	6	10	15
100	4"	135	18	10	12	15
125	5"	170	18	10	12	15
150	6"	180	18	10	12	15
200	8"	205	25	14	22	15
250	10"	240	25	14	22	15
300	12"	260	25	14	22	15
350	14"	265	25	16	22	15
400	16"	265	25	16	22	15
450	18"	265	25	16	22	15
500	20"	265	25	16	22	15

GD_JOINT_A_TD

VIBRATION DAMPERS

TYPE	SHORE	DIMENSIONS (mm)			
		ø A	H	L	M
VIBRATION DAMPER P20X20	60	20	20	18	6
VIBRATION DAMPER P40X30	60	40	30	23	8
VIBRATION DAMPER P100X50	60	100	50	50	16

Note: Available versions M/F and F/F

bst-ant-piedini-en_a_td

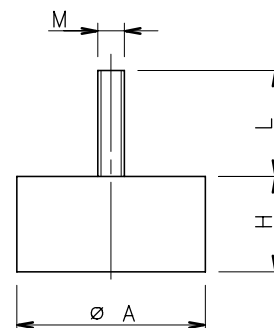

BST-ANT-PIED_A_DD

DRY RUNNING PROTECTION SYSTEMS

Dry run shutdown systems should be installed to protect the pumps in case of insufficient water supply.

FLOAT SWITCH PROTECTION METHOD

The float switch protection system is used when the water supply comes from open tanks. A float switch immersed in the tank is connected to the electrical panel.

If the water supply is insufficient, the float switch opens the electric contact and the pumps stop running.

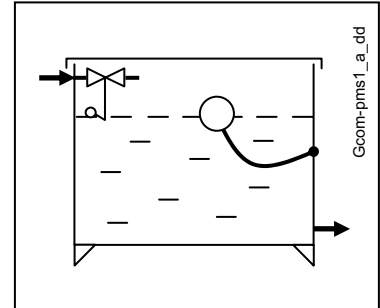

ELECTRODE PROBE PROTECTION METHOD

The electrode probe protection system is used when the water supply comes from open tanks or wells. A set of three probes is connected directly to the electronic board in the electrical panel. With the three electrodes immersed in the water, the relay on the electronic board closes the contact, enabling the starting of the pumps. If the water supply is insufficient, the control circuit opens the electric contact and the pumps stop running.

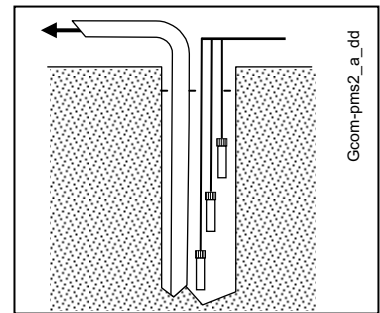

MINIMUM PRESSURE SWITCH PROTECTION METHOD

The minimum pressure switch protection system is used when the water supply comes from water networks or pressurized tanks. The pressure switch is connected to the electronic board in the electrical panel.

If the water supply is insufficient, the pressure switch opens the electric contact and the pumps stop running.

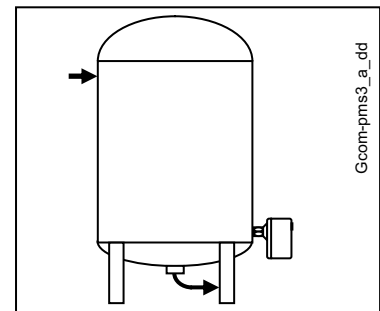

TECHNICAL APPENDIX

WATER REQUIREMENTS IN CIVIL USERS

Determination of the water requirement depends on the type of users and contemporaneity factor. The calculation may be subject to regulations, standards or customs that may vary from country to country. The calculation method shown below is an example based on practical experience, designed to provide a reference value and not a substitute for detailed analytical calculation.

Water requirements in condominiums

The **consumption table** shows the maximum values for each delivery point, depending on the plumbing amenities.

MAXIMUM CONSUMPTION FOR EACH DELIVERY POINT

TYPE	CONSUMPTION (l/min)
Sink	9
Dishwasher	10
Washing machine	12
Shower	12
Bathtub	15
Washbasin	6
Bidet	6
Flush tank WC	6
Controlled flushing system WC	90

G-at-cm_a_th

The **sum of the water consumption values** of each delivery point determines the maximum theoretical requirement, which must be reduced according to the **contemporaneity coefficient**, because in actual fact the delivery points are never used all together.

$f = \frac{1}{\sqrt{(0,857 \times Nr \times Na)}}$	Coefficient for apartments with one bathroom and flush tank WC
$f = \frac{1}{\sqrt{(0,857 \times Nr \times Na)}}$	Coefficient for apartments with one bathroom and controlled flushing system WC
$f = \frac{1,03}{\sqrt{(0,545 \times Nr \times Na)}}$	Coefficient for apartments with two bathrooms and flush tank WC
$f = \frac{0,8}{\sqrt{(0,727 \times Nr \times Na)}}$	Coefficient for apartments with two bathrooms and controlled flushing system WC

f= coefficient; Nr= number of delivery points; Na= number of apartments

The **table of water requirements in civil users** shows the maximum contemporaneity flow-rate values based on the **number of apartments** and the type of WC for apartments with one bathroom and two bathrooms. As regards apartments with one bathroom, 7 drawing points have been taken into consideration, while 11 points have been considered for apartments with two bathrooms. If the number of drawing points or apartments is different, use the formulas to **calculate** the requirement.

TABLE OF WATER REQUIREMENTS IN CIVIL USERS

NUMBER OF APARTMENTS	WITH FLUSH TANK WC		WITH CONTROLLED FLUSHING SYSTEM WC	
	1	2	1	2
	FLOW RATE (l/min)			
1	32	40	60	79
2	45	56	85	111
3	55	68	105	136
4	63	79	121	157
5	71	88	135	176
6	78	97	148	193
7	84	105	160	208
8	90	112	171	223
9	95	119	181	236
10	100	125	191	249
11	105	131	200	261
12	110	137	209	273
13	114	143	218	284
14	119	148	226	295
15	123	153	234	305
16	127	158	242	315
17	131	163	249	325
18	134	168	256	334
19	138	172	263	343
20	142	177	270	352
21	145	181	277	361
22	149	185	283	369
23	152	190	290	378
24	155	194	296	386
25	158	198	302	394
26	162	202	308	401
27	165	205	314	409
28	168	209	320	417
29	171	213	325	424
30	174	217	331	431
35	187	234	357	466
40	200	250	382	498
45	213	265	405	528
50	224	280	427	557
55	235	293	448	584
60	245	306	468	610
65	255	319	487	635
70	265	331	506	659
75	274	342	523	682
80	283	354	540	704
85	292	364	557	726
90	301	375	573	747
95	309	385	589	767
100	317	395	604	787
120	347	433	662	863
140	375	468	715	932
160	401	500	764	996
180	425	530	811	1056
200	448	559	854	1114

For seaside resorts, a flow rate increased by at least 20% must be considered.

G-at-fi_a_th

WATER REQUIREMENTS FOR COMMUNITY BUILDINGS

The requirements of buildings intended for specific uses, such as **offices, residential units, hotels, department stores, nursing homes** and so on, are different from those of condominiums, and both their global daily water consumption and the maximum contemporaneity flow rate are usually greater. The **diagram of water requirements for community buildings** shows the maximum contemporaneity flow rate of some types of communities, for guidance.

These requirements must be determined case by case with the utmost accuracy, using analytical calculation methods, according to particular needs and local provisions.

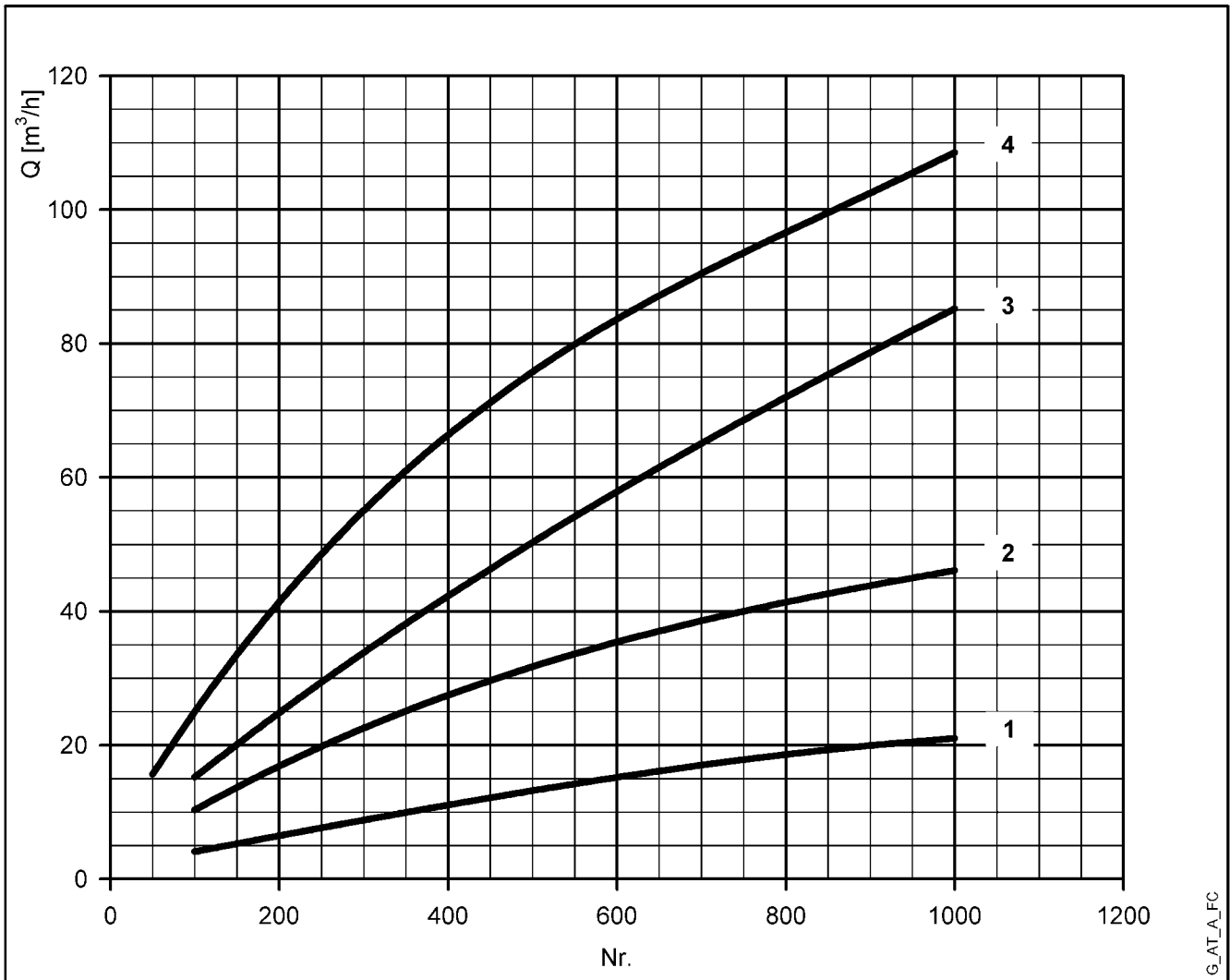

For seaside resorts, the flow rate must be increased by at least 20%.

- 1 = Offices (N. of people)
- 2 = Department stores (N. of people)
- 3 = Nursing homes (N. of beds)
- 4 = Hotels, residences (N. of beds)

USE OF BOOSTER SET

Water is usually delivered by public supply systems and the pressure is generally sufficient for the proper operation of the users' water and sanitary equipment.

When this pressure is not sufficient, booster sets are employed to increase water pressure and ensure an acceptable minimum value at the furthest points. Therefore, the water supply to a building, group of buildings or to a system in general can be considered satisfactory when all the user points can deliver the required quantity of water.

Set connection methods (intake side)

Water can be supplied to a booster set in two ways:

- 1 - By installing a water storage tank between the user's offtake and the booster set (indirect connection, fig. 7.1.1).
- 2 - By connecting the booster set directly between the user's offtake and the system (direct connection, fig. 7.1.1).

The indirect connection does not allow the water system pressure to be utilized. Therefore, it requires pumps with greater head.

The direct connection allows the water system pressure to be utilized, provided the pressure fluctuation (Δp) does not exceed 1 bar.

If it does, a pressure reducer must be installed for proper operation of the booster set.

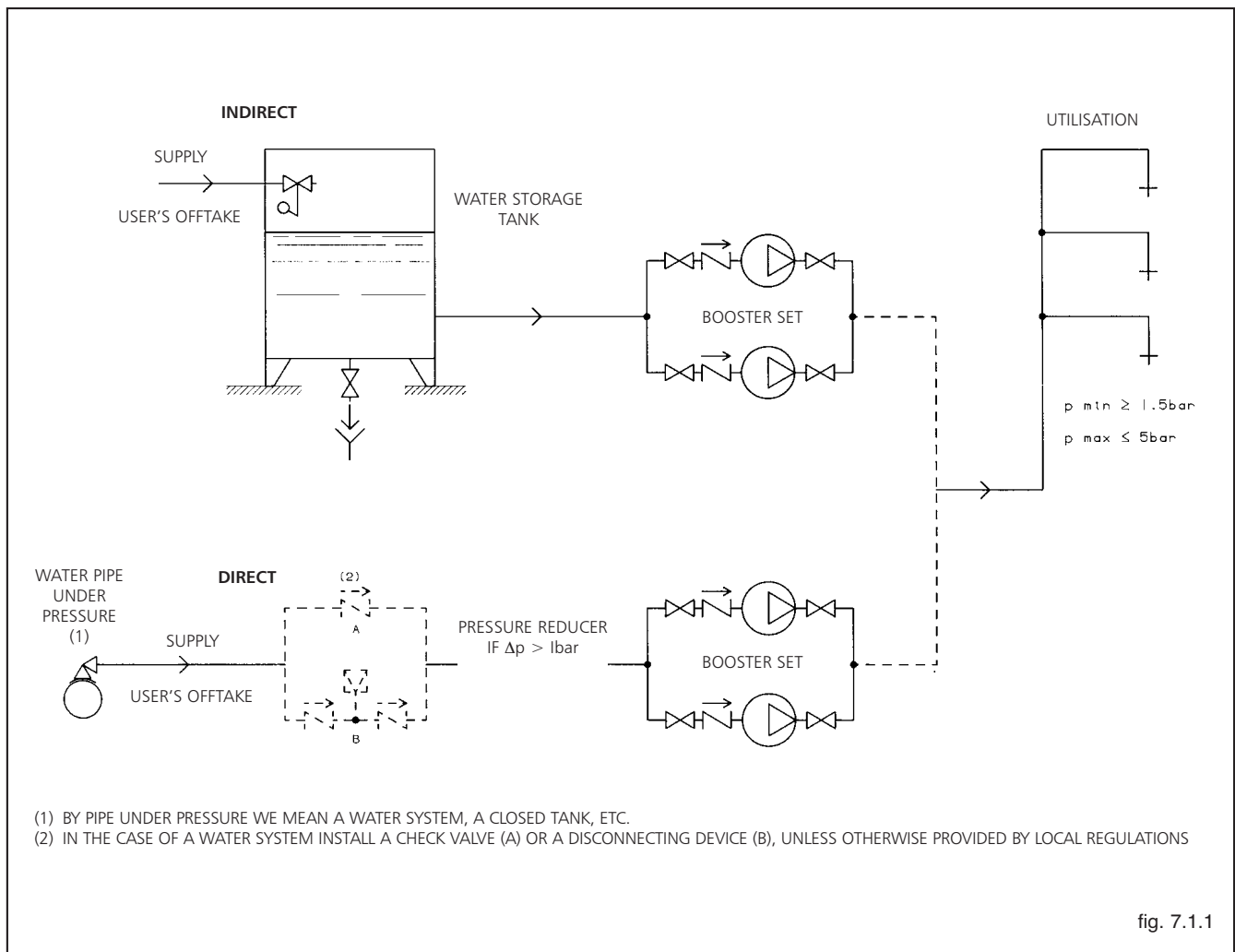

fig. 7.1.1

Water supply systems in civil buildings

The configuration of the supply system must comply with the following conditions:

- The minimum pressure ensuring the proper operation of the equipment must be guaranteed at the most unfavourable drawing point (1.5 bar for valves and flush tank WC, and 2 bar for controlled flushing system WC).
- At the most favourable drawing point, pressure must not exceed 5 bar.

Once these parameters have been satisfied, in relation to the height of the building and to the set intake conditions, the water supply system can have one of the following configurations:

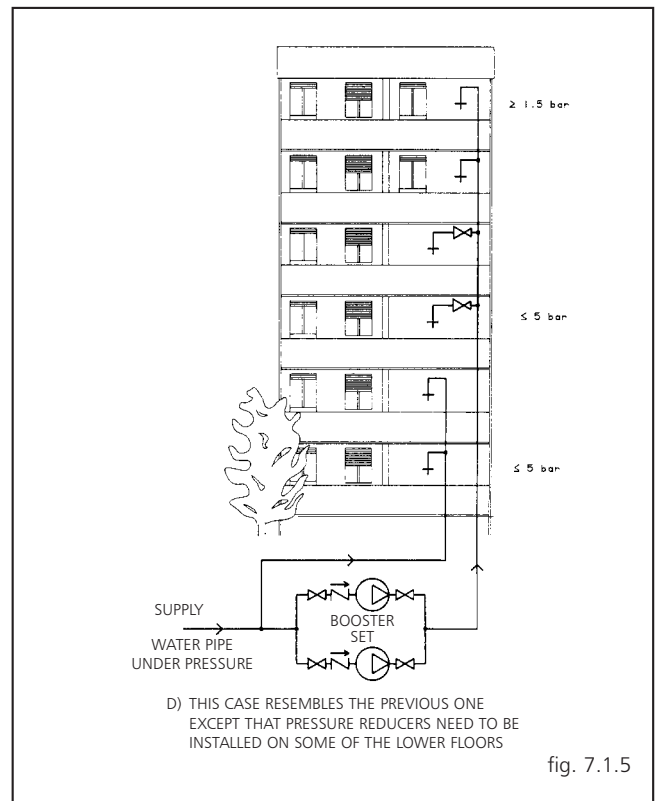
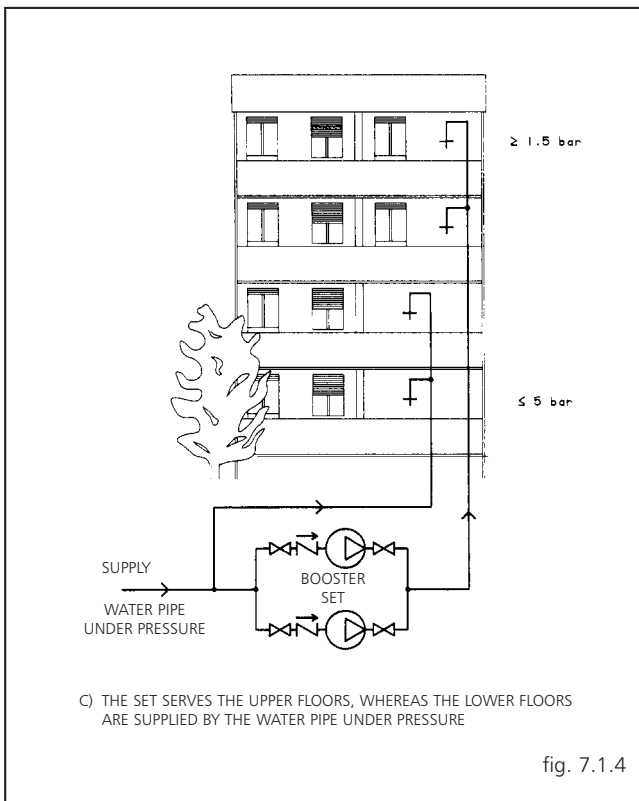
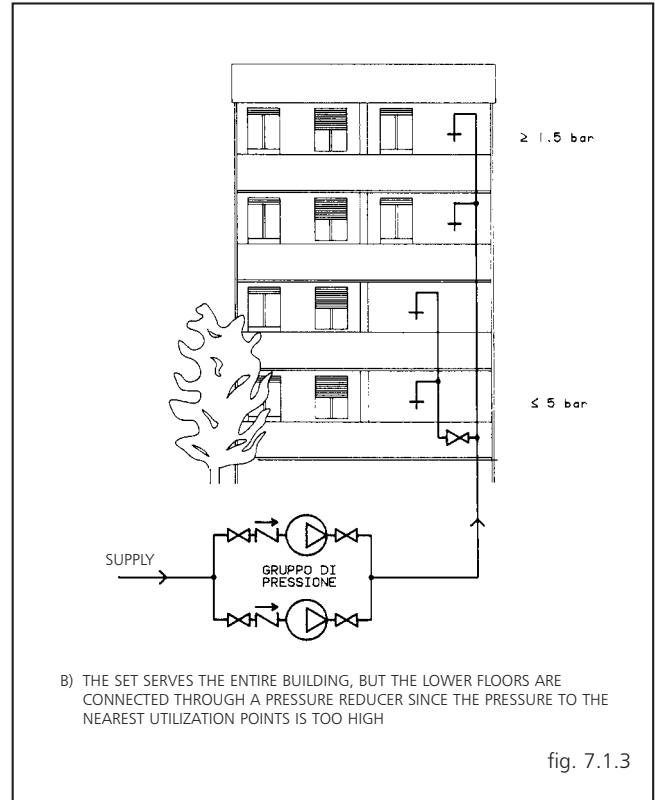
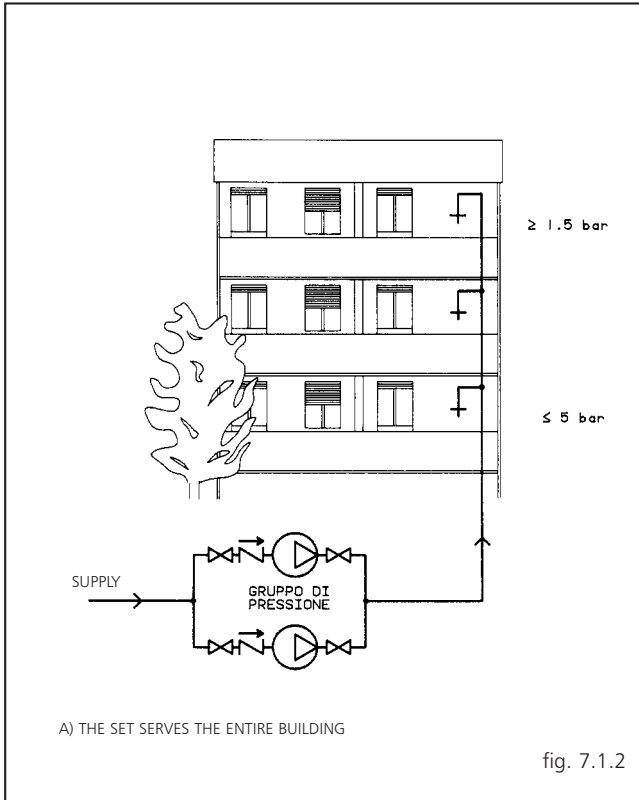

DETERMINING THE HEAD OF THE SET AND INTAKE CONDITIONS

Level intake

The delivery head of the set (H_{tot}) is the sum of:

- H_e : geodetic difference in level between the set and the furthest delivery point.
- H_c : flow resistance along all the pipes and through other system components, such as valves, filters, etc..
- H_r : pressure required at the most unfavourable point.

$$H_{tot} = H_e + H_c + H_r$$

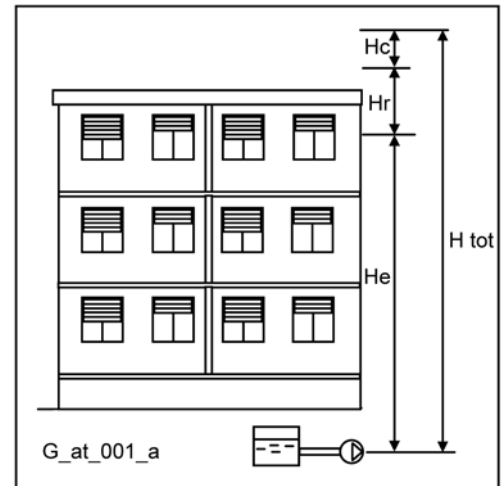

Intake with positive head

In this case, the necessary delivery head (H_{tot}) will be reduced by the inlet pressure value (H_i).

$$H_{tot} = H_e + H_c + H_r - H_i$$

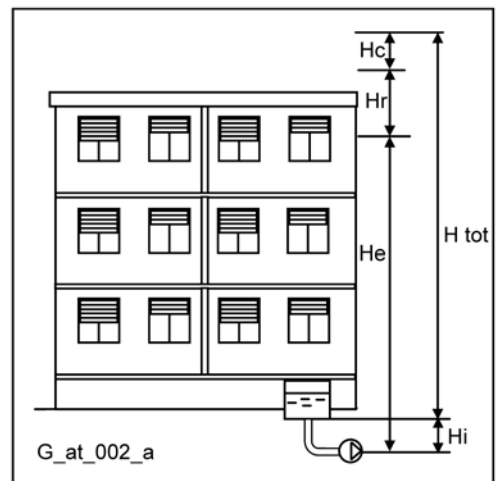

Intake with negative head

When the pumps suck from an underground tank or well, the necessary head will be increased by the value of the intake height (H_a):.

$$H_{tot} = H_e + H_c + H_r + H_a$$

In this case the intake height must be considered very carefully, bearing in mind that an excessive difference in level between the water storage tank and the set, or the wrong sizing of the intake pipe, can have adverse effects on pump operation, such as cavitation and unpriming.

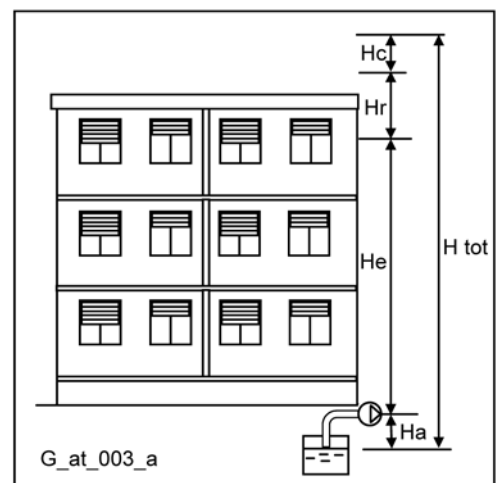

NPSH

The minimum operating values that can be reached at the pump suction end are limited by the onset of cavitation.

Cavitation is the formation of vapour-filled cavities within liquids where the pressure is locally reduced to a critical value, or where the local pressure is equal to, or just below the vapour pressure of the liquid.

The vapour-filled cavities flow with the current and when they reach a higher pressure area the vapour contained in the cavities condenses. The cavities collide, generating pressure waves that are transmitted to the walls. These, being subjected to stress cycles, gradually become deformed and yield due to fatigue. This phenomenon, characterized by a metallic noise produced by the hammering on the pipe walls, is called incipient cavitation.

The damage caused by cavitation may be magnified by electrochemical corrosion and a local rise in temperature due to the plastic deformation of the walls. The materials that offer the highest resistance to heat and corrosion are alloy steels, especially austenitic steel. The conditions that trigger cavitation may be assessed by calculating the total net suction head, referred to in technical literature with the acronym NPSH (Net Positive Suction Head).

The NPSH represents the total energy (expressed in m.) of the liquid measured at suction under conditions of incipient cavitation, excluding the vapour pressure (expressed in m.) that the liquid has at the pump inlet.

To find the static height h_z at which to install the machine under safe conditions, the following formula must be verified:

$$h_p + h_z \geq (\text{NPSH}_r + 0.5) + h_f + h_{pv} \quad \textcircled{1}$$

where:

- h_p** is the absolute pressure applied to the free liquid surface in the suction tank, expressed in m. of liquid; h_p is the quotient between the barometric pressure and the specific weight of the liquid.
- h_z** is the suction lift between the pump axis and the free liquid surface in the suction tank, expressed in m.; h_z is negative when the liquid level is lower than the pump axis.
- h_f** is the flow resistance in the suction line and its accessories, such as: fittings, foot valve, gate valve, elbows, etc.
- h_{pv}** is the vapour pressure of the liquid at the operating temperature, expressed in m. of liquid. h_{pv} is the quotient between the Pv vapour pressure and the liquid's specific weight.
- 0,5** is the safety factor.

The maximum possible suction head for installation depends on the value of the atmospheric pressure (i.e. the elevation above sea level at which the pump is installed) and the temperature of the liquid.

To help the user, with reference to water temperature (4° C) and to the elevation above sea level, the following tables show the drop in hydraulic pressure head in relation to the elevation above sea level, and the suction loss in relation to temperature.

Water temperature (°C)	20	40	60	80	90	110	120
Suction loss (m)	0,2	0,7	2,0	5,0	7,4	15,4	21,5

Elevation above sea level (m)	500	1000	1500	2000	2500	3000
Suction loss (m)	0,55	1,1	1,65	2,2	2,75	3,3

Friction loss is shown in the tables at pages 127-128 of this catalogue. To reduce it to a minimum, especially in cases of high suction head (over 4-5 m.) or within the operating limits with high flow rates, we recommend using a suction line having a larger diameter than that of the pump's suction port. It is always a good idea to position the pump as close as possible to the liquid to be pumped.

Make the following calculation:

Liquid: water at ~15°C $\gamma = 1 \text{ kg/dm}^3$

Flow rate required: 30 m³/h

Head for required delivery: 43 m.

Suction lift: 3,5 m.

The selection is an FHE 40-200/75 pump whose NPSH required value is, at 30 m³/h, di 2,5 m.

For water at 15 °C

$$h_p = P_a / \gamma = 10,33\text{m}, h_{pv} = P_v / \gamma = 0,174\text{m} (0,01701 \text{ bar})$$

The H_f flow resistance in the suction line with foot valves is ~ 1,2 m.

By substituting the parameters in formula $\textcircled{1}$ with the numeric values above, we have:

$$10,33 + (-3,5) \geq (2,5 + 0,5) + 1,2 + 0,17$$

from which we have: 6,8 > 4,4

The relation is therefore verified.

TECHNICAL APPENDIX VAPOUR PRESSURE PS VAPOUR PRESSURE AND ρ DENSITY OF WATER TABLE

t °C	T K	ps bar	ρ kg/dm ³	t °C	T K	ps bar	ρ kg/dm ³	t °C	T K	ps bar	ρ kg/dm ³
0	273,15	0,00611	0,9998	55	328,15	0,15741	0,9857	120	393,15	1,9854	0,9429
1	274,15	0,00657	0,9999	56	329,15	0,16511	0,9852	122	395,15	2,1145	0,9412
2	275,15	0,00706	0,9999	57	330,15	0,17313	0,9846	124	397,15	2,2504	0,9396
3	276,15	0,00758	0,9999	58	331,15	0,18147	0,9842	126	399,15	2,3933	0,9379
4	277,15	0,00813	1,0000	59	332,15	0,19016	0,9837	128	401,15	2,5435	0,9362
5	278,15	0,00872	1,0000	60	333,15	0,1992	0,9832	130	403,15	2,7013	0,9346
6	279,15	0,00935	1,0000	61	334,15	0,2086	0,9826	132	405,15	2,867	0,9328
7	280,15	0,01001	0,9999	62	335,15	0,2184	0,9821	134	407,15	3,041	0,9311
8	281,15	0,01072	0,9999	63	336,15	0,2286	0,9816	136	409,15	3,223	0,9294
9	282,15	0,01147	0,9998	64	337,15	0,2391	0,9811	138	411,15	3,414	0,9276
10	283,15	0,01227	0,9997	65	338,15	0,2501	0,9805	140	413,15	3,614	0,9258
11	284,15	0,01312	0,9997	66	339,15	0,2615	0,9799	145	418,15	4,155	0,9214
12	285,15	0,01401	0,9996	67	340,15	0,2733	0,9793	155	428,15	5,433	0,9121
13	286,15	0,01497	0,9994	68	341,15	0,2856	0,9788	160	433,15	6,181	0,9073
14	287,15	0,01597	0,9993	69	342,15	0,2984	0,9782	165	438,15	7,008	0,9024
15	288,15	0,01704	0,9992	70	343,15	0,3116	0,9777	170	443,15	7,920	0,8973
16	289,15	0,01817	0,9990	71	344,15	0,3253	0,9770	175	448,15	8,924	0,8921
17	290,15	0,01936	0,9988	72	345,15	0,3396	0,9765	180	453,15	10,027	0,8869
18	291,15	0,02062	0,9987	73	346,15	0,3543	0,9760	185	458,15	11,233	0,8815
19	292,15	0,02196	0,9985	74	347,15	0,3696	0,9753	190	463,15	12,551	0,8760
20	293,15	0,02337	0,9983	75	348,15	0,3855	0,9748	195	468,15	13,987	0,8704
21	294,15	0,24850	0,9981	76	349,15	0,4019	0,9741	200	473,15	15,550	0,8647
22	295,15	0,02642	0,9978	77	350,15	0,4189	0,9735	205	478,15	17,243	0,8588
23	296,15	0,02808	0,9976	78	351,15	0,4365	0,9729	210	483,15	19,077	0,8528
24	297,15	0,02982	0,9974	79	352,15	0,4547	0,9723	215	488,15	21,060	0,8467
25	298,15	0,03166	0,9971	80	353,15	0,4736	0,9716	220	493,15	23,198	0,8403
26	299,15	0,03360	0,9968	81	354,15	0,4931	0,9710	225	498,15	25,501	0,8339
27	300,15	0,03564	0,9966	82	355,15	0,5133	0,9704	230	503,15	27,976	0,8273
28	301,15	0,03778	0,9963	83	356,15	0,5342	0,9697	235	508,15	30,632	0,8205
29	302,15	0,04004	0,9960	84	357,15	0,5557	0,9691	240	513,15	33,478	0,8136
30	303,15	0,04241	0,9957	85	358,15	0,5780	0,9684	245	518,15	36,523	0,8065
31	304,15	0,04491	0,9954	86	359,15	0,6011	0,9678	250	523,15	39,776	0,7992
32	305,15	0,04753	0,9951	87	360,15	0,6249	0,9671	255	528,15	43,246	0,7916
33	306,15	0,05029	0,9947	88	361,15	0,6495	0,9665	260	533,15	46,943	0,7839
34	307,15	0,05318	0,9944	89	362,15	0,6749	0,9658	265	538,15	50,877	0,7759
35	308,15	0,05622	0,9940	90	363,15	0,7011	0,9652	270	543,15	55,058	0,7678
36	309,15	0,05940	0,9937	91	364,15	0,7281	0,9644	275	548,15	59,496	0,7593
37	310,15	0,06274	0,9933	92	365,15	0,7561	0,9638	280	553,15	64,202	0,7505
38	311,15	0,06624	0,9930	93	366,15	0,7849	0,9630	285	558,15	69,186	0,7415
39	312,15	0,06991	0,9927	94	367,15	0,8146	0,9624	290	563,15	74,461	0,7321
40	313,15	0,07375	0,9923	95	368,15	0,8453	0,9616	295	568,15	80,037	0,7223
41	314,15	0,07777	0,9919	96	369,15	0,8769	0,9610	300	573,15	85,927	0,7122
42	315,15	0,08198	0,9915	97	370,15	0,9094	0,9602	305	578,15	92,144	0,7017
43	316,15	0,09639	0,9911	98	371,15	0,9430	0,9596	310	583,15	98,70	0,6906
44	317,15	0,09100	0,9907	99	372,15	0,9776	0,9586	315	588,15	105,61	0,6791
45	318,15	0,09582	0,9902	100	373,15	1,0133	0,9581	320	593,15	112,89	0,6669
46	319,15	0,10086	0,9898	102	375,15	1,0878	0,9567	325	598,15	120,56	0,6541
47	320,15	0,10612	0,9894	104	377,15	1,1668	0,9552	330	603,15	128,63	0,6404
48	321,15	0,11162	0,9889	106	379,15	1,2504	0,9537	340	613,15	146,05	0,6102
49	322,15	0,11736	0,9884	108	381,15	1,3390	0,9522	350	623,15	165,35	0,5743
50	323,15	0,12335	0,9880	110	383,15	1,4327	0,9507	360	633,15	186,75	0,5275
51	324,15	0,12961	0,9876	112	385,15	1,5316	0,9491	370	643,15	210,54	0,4518
52	325,15	0,13613	0,9871	114	387,15	1,6362	0,9476	374,15	647,30	221,20	0,3154
53	326,15	0,14293	0,9862	116	389,15	1,7465	0,9460				
54	327,15	0,15002	0,9862	118	391,15	1,8628	0,9445				

G-at_nps_h_a_sc

TECHNICAL APPENDIX

CHOOSING AND SIZING THE SURGE TANK

The purpose of the surge tank is to limit the number of hourly starts of the pumps, placing part of its stock of water, which is maintained under pressure by the air above it, at the disposal of the system.

The surge tank can be of the air cushion or diaphragm type.

In the air cushion version there is no clear separation between air and water. Since part of the air tends to mix with water, it is necessary to restore it by means of air supply units or a compressor.

In the diaphragm version, neither air supply units nor compressor are needed, as contact between air and water is prevented by a flexible diaphragm inside the tank.

The following method, which is used to determine the volume of a surge tank, is valid both for horizontal and vertical surge tanks.

When calculating the volume of the surge tank, it is generally sufficient to consider the first pump only.

AIR-CUSHION SURGE TANK

It is determined in relation to flow rate, pump pressure, and number of starts per hour allowed by the motor.

$$V_a = \frac{1,25 \times Q_p \times (P_{max} + 10)}{4 \times Z \times (P_{max} - P_{min})}$$

where:

- V_a = Total volume of the air-cushion surge tank in m^3
- Q_p = Average pump flow rate in m^3/h
- P_{max} = Maximum pressure setting (wcm)
- P_{min} = Minimum pressure setting (wcm)
- Z = Maximum number of starts per hour allowed by the motor

Warning! By pump flow rate we mean the average between the flow rate at the maximum pressure switch setting (Q_{max}) and the flow rate at the minimum pressure switch setting (Q_{min}), i.e.:

$$Q_p = \frac{Q_{max} + Q_{min}}{2} \quad (m^3/h)$$

Example:

- CN 32 - 160/22 pump
- P_{max} = 32 mca
- P_{min} = 22 mca
- Q_p = 18 m^3/h
- Z = 30

$$V_a = \frac{1,25 \times 18 \times (32 + 10)}{4 \times 30 \times (32 - 22)} = 0,788 \text{ m}^3$$

A 750-litre surge tank is therefore required.

DIAPHRAGM TANK

If you decide to use a diaphragm tank, the volume will be lower than that of the air-cushion tank. It can be calculated with the following formula:

$$V_m = \frac{Q_p}{4 \times Z} \times \frac{1}{1 - \frac{(P_{min} - 2)}{P_{max}}}$$

where:

- V_m = Total volume of the air-cushion surge tank in m^3
- Q_p = Average pump flow rate in m^3/h
- P_{max} = Maximum pressure setting (wcm)
- P_{min} = Minimum pressure setting (wcm)
- Z = Maximum number of starts per hour allowed by the motor

Example:

- CN 32 - 160/22 pump
- P_{max} = 32 mca
- P_{min} = 22 mca
- Q_p = 18 m^3/h
- Z = 30

$$V_m = \frac{Q_p}{4 \times Z} \times \frac{1}{1 - \frac{(P_{min} - 2)}{P_{max}}} = 0,4 \text{ m}^3$$

A 500-litre surge tank is therefore required.

Approximate comparison between Lowara air-cushion tanks and diaphragm tanks, as regards some pressure switch setting values

NOMINAL CAPACITY OF AIR CUSHION TANK (litres)	PRESSURE SWITCH SETTING (bar) min/max									
	1,5/2,5	2/3	2,5/3,5	3/4	3,5/4,5	4/5	4,5/5,5	5/6	5,5/6,5	6/7
	NOMINAL CAPACITY OF DIAPHRAGM VESSEL (litres)									
100	N°2 ball type vessels/cylinder type vessels or 60l Export tank or 100-litre vessels (ISPESL tested)									
200	100									
300	200									
500	300									
1000	500									
1500	500 + 200		500 + 300							
2000	500 + 500									
2500	500 + 500	500 + 500 + 300								500 + 500

s_swp-en_a_th

FLOW RESISTANCE

TABLE OF FLOW RESISTANCE IN BENDS, VALVES AND GATES

The flow resistance is calculated using the equivalent pipeline length method according to the table below:

ACCESSORY TYPE	DN											
	25	32	40	50	65	80	100	125	150	200	250	300
	Equivalent pipeline length (m)											
45° bend	0,2	0,2	0,4	0,4	0,6	0,6	0,9	1,1	1,5	1,9	2,4	2,8
90° bend	0,4	0,6	0,9	1,1	1,3	1,5	2,1	2,6	3,0	3,9	4,7	5,8
90° smooth bend	0,4	0,4	0,4	0,6	0,9	1,1	1,3	1,7	1,9	2,8	3,4	3,9
Union tee or cross	1,1	1,3	1,7	2,1	2,6	3,2	4,3	5,3	6,4	7,5	10,7	12,8
Gate	-	-	-	0,2	0,2	0,2	0,4	0,4	0,6	0,9	1,1	1,3
Non return valve	1,1	1,5	1,9	2,4	3,0	3,4	4,7	5,9	7,4	9,6	11,8	13,9

G-a-pcv_a_th

The table is valid for the Hazen Williams coefficient $C = 100$ (cast iron pipework). For steel pipework, multiply the values by 1.41. For stainless steel, copper and coated cast iron pipework, multiply the values by 1.85.

When the **equivalent pipeline length** has been determined, the flow resistance is obtained from the table of flow resistance.

The values given are guideline values which are bound to vary slightly according to the model, especially for gate valves and non-return valves, for which it is a good idea to check the values supplied by the manufacturers.

Air supply unit

The most commonly used air supply unit model is the "depression" type, which uses the depression produced by the pump suction.

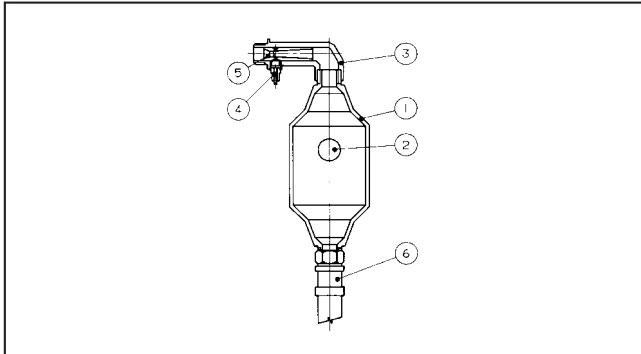

fig. 7.2.2 - The air supply unit consists of a body made of plastic material suitable for foodstuffs (1), a spherical rubber shutter (2), an upper brass union (3) with an air valve (4), a Venturi tube (5), and a flexible pipe (6) to be connected to the pump intake.

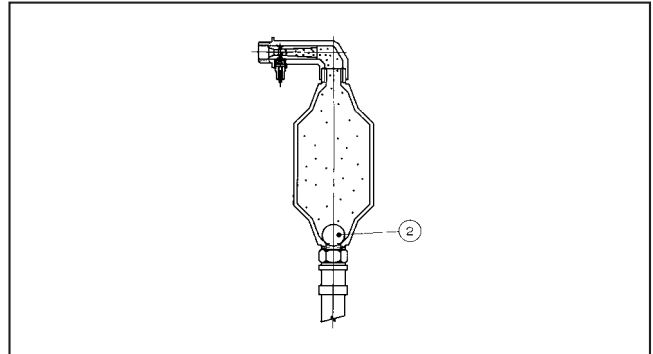

fig. 7.2.5 - The air accumulated inside the body pushes the rubber ball (2) to the bottom, thus blocking the passage. At this point the valve closes and the rubber ball prevents the air accumulated inside the body of the air supply unit from reaching the pump intake.

Air supply unit operation

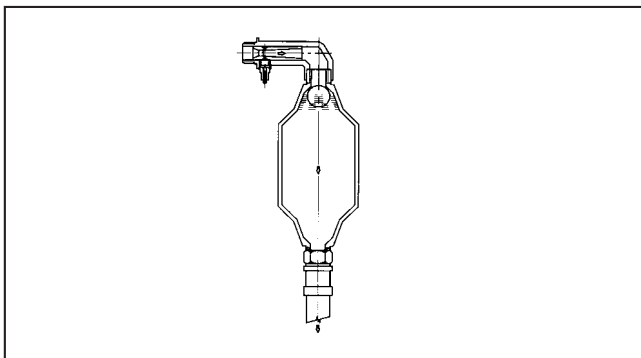

fig. 7.2.3 - When the pump starts up, the intake pressure is lower than the pressure in the surge tank. This difference causes water to flow from the surge tank to the pump intake, through the air supply unit.

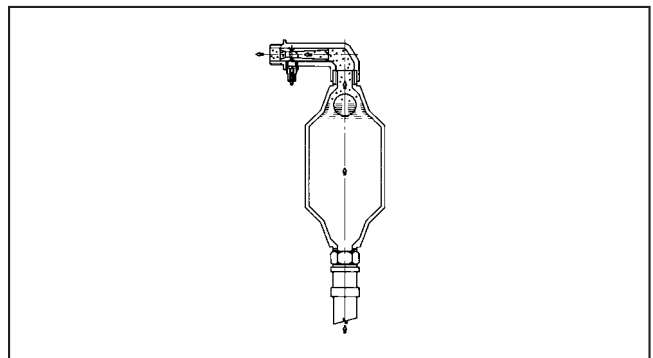

fig. 7.2.6 - When the pump stops the depression ceases and a flow of water is produced, which lifts the ball and pushes the air in the body of the supply unit into the tank.

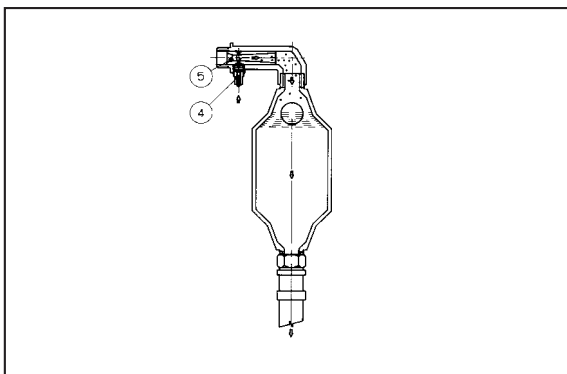

fig. 7.2.4 - The flow of water that passes through the Venturi tube (5) generates a depression and allows the opening of the air valve (4). As a consequence, air enters the body of the supply unit.

Air supply unit selection tank

TANK CAPACITY L	AVERAGE PRESSURE SETTING bar					
	2.5	3.5	4.5	5.5	6.5	7.5
100	LOW 5					
200						
300						
500	LOW 10					
700						
1000	LOW 25					
1500						
2000						
2500	LOW 40					
3000						
4000						
5000						
6000						

g_air-en_a_th

This cycle is repeated each time the pump starts up until the required quantity of air has accumulated. To ensure proper system operation, no check valve must be mounted between the pump delivery outlet and the surge tank, as it would impede the return flow of water through the pump.

ASSESSMENT OF PROBABLE DEMAND (VALID IN U.K. ONLY)

The method adopted is based on loading unit values as detailed in the Plumbing Engineering Design Guide published by the Institute of Plumbing.

When designing a hot or cold water supply system an assessment must be made to obtain the maximum probable simultaneous demand.

Depending on the type of services being provided it rarely occurs for all the appliances to be used at the same time therefore the design usually allows for a peak usage which is less than the maximum.

Probable demand will depend on the type of building and its use, type of appliances installed and frequency of use.

The simultaneous demand in most installations can be calculated with an adequate degree of accuracy using the loading unit concept.

The usage patterns and types of appliances in different installations will vary greatly.

Sports and Leisure centres for example are usually calculated directly by the flow rates of each appliance, without diversity factors. Each case will need to be looked at in its own right and assessed accordingly. Judgement of the designer must prevail.

Loading unit values vary for each type of appliance. A loading unit has no precise value in terms of litres per second.

See loading unit table below.

By multiplying the total number of each appliance by the appropriate loading unit number and adding the resultant totals together, the recommended flow can be read from the chart.

Loading unit table

APPLIANCE	Loading Unit	Recommended Flow L/s
WC	1,5	0,12
Wash basin (hot & cold)	3	0,3
Sink (hot & cold)	6	0,4
Bath (hot & cold)	20	0,6
Shower (hot & cold)	10	0,24
Washing machine	2	0,3

g_at_a_LU

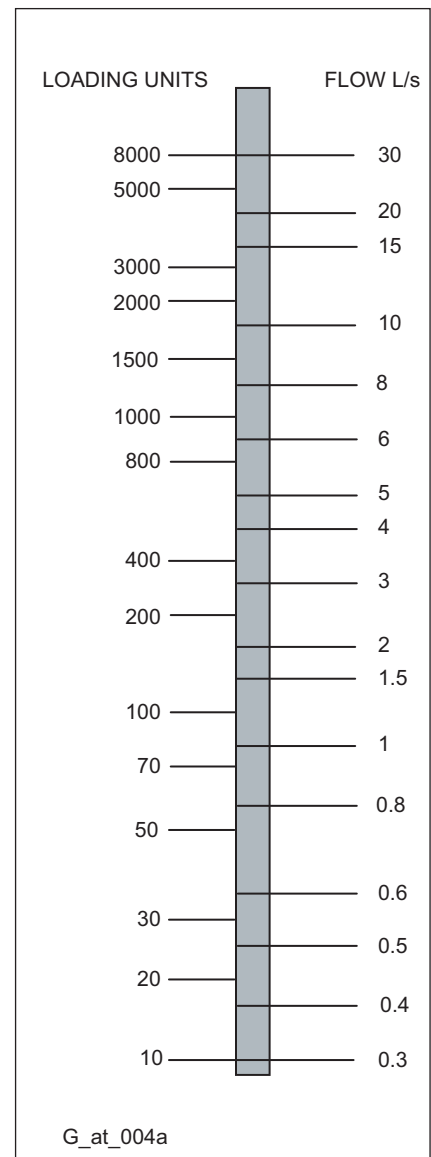

Working Example

A block of standard flats containing a total of 70 dwellings

Each standard flat is assumed to have:

1 x Hand basin hot & cold = 3 L/U x 70 = 210

1 x WC cold only = 1.5 L/U x 70 = 105

1 x Shower hot & cold = 10 L/U x 70 = 700

1 x Sink hot & cold = 6 L/U x 70 = 420

Total Loading Unit = 1435

This figure can now be read from the chart opposite: total flow = 8.5 L/s

ASSESSING HEAD REQUIREMENT (VALID IN U.K. ONLY)

The **head** required in a boosted cold water system consists of three components, static head, residual pressure and system friction losses. The values of these three components are added together to give the total required head at the system flow rate.

Static head (He): This is the difference between the break tank low water line and the highest discharge point in the building. If the height of the build is not known, then 2.8-3.0 metres per floor can be used to assess the building height.

Residual pressure (Hr): This is the pressure required at the highest outlet device, normally 20metres.

Note: some modern showers may require higher pressures.

System friction losses (Hc): The total losses through pipework, pipework fittings, valves, PRVs and all other equipment fed through the pumpset must be added to find the total system losses.

On conventional systems that do not include excessive runs of pipe or specialised components a rough guide would be to allow 0.05 metres friction loss for each metre of static head.

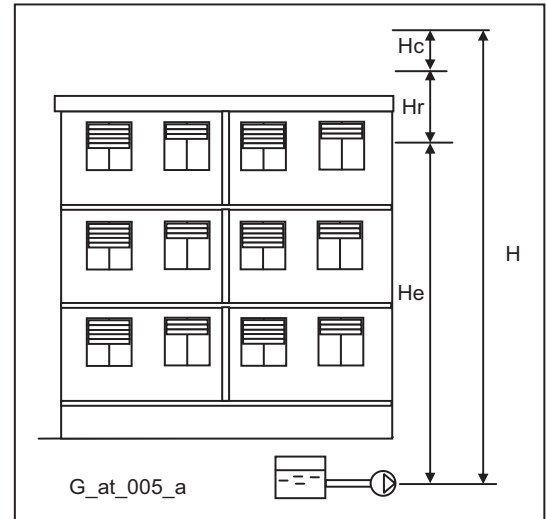

Example:

Static head (He): Building height four floors @ 2.8m each = 11.2m +
 Residual pressure (Hr): Pressure at highest outlet = 20m +
 Friction losses (Hc): 11.2 (static head) x 0.05 = 0.56m
 Total pump head required (H) = 31.76m (3.11 Bar)

Pressure limitations

The designer must ensure that adequate precautions are taken to ensure that the system is capable of withstanding the closed valve head produced by the pump set. In cases where closed valve pressures cannot be tolerated, pressure reducing valves should be fitted down stream of the booster set.

Velocity

Pipework within the system should be sized to limit the velocity to the figures stated in table below.

Higher velocities will lead to excessive noise, wear and higher running costs.

PIPE SIZE	SUCTION PIPE m/s	DELIVERY PIPE m/s
Less than 80mm	0,46	0,91 to 1,07
100-150mm	0,55	1,22 to 1,52
200mm	0,76	1,68
250 and above	0,91	1,82 to 2,13

g_at_a_fs

BOOSTER SIZING

What information do we require to size a booster set?

- As a minimum we need to know:
 - The total flow rate, or information to assess this.
 - The total head at flow rate, or the height of building.
 - If the pumps are to operate under positive head, or suction lift conditions.
 - Where the set is to be sited, I.E. basement or roof.
 - Preferred choice fixed or variable speed
- Additional information if available:
 - How to split the duty for particular applications I.E. duty/standby or duty/assist.
 - The size and material of the connecting pipework.
 - Is a Jockey pump required.

ACCESSORIES



AIR SUPPLY UNITS



FLOAT SWITCHES



VALVES



CYLINDER WATER TANK

**TECHNICAL
APPENDIX**



NON-RETURN VALVES



COUPLINGS



PRESSURE TRANSMITTER

VOLUMETRIC CAPACITY

Litres per minute l/min	Cubic metres per hour m ³ /h	Cubic feet per hour ft ³ /h	Cubic feet per minute ft ³ /min	Imp. gal. per minute Imp. gal./min	US gal. per minute Us gal./min
1,000	0,0600	2,1189	0,0353	0,2200	0,2642
16,6667	1,000	35,3147	0,5886	3,6662	4,4029
0,4719	0,0283	1,000	0,0167	0,1038	0,1247
28,3168	1,6990	60,0000	1,000	6,2288	7,4805
4,5461	0,2728	9,6326	0,1605	1,000	1,2009
3,7854	0,2271	8,0208	0,1337	0,8327	1,000

PRESSURE AND HEAD

Newton per square metre N/m ²	kilo Pascal kPa	bar bar	Pound force per square inch psi	metre of water m H ₂ O	millimetre of mercury mm Hg
1,000	0,0010	1 x 10 ⁻⁵	1.45 x 10 ⁻⁴	1.02 x 10 ⁻⁴	0,0075
1000,0000	1,000	0,0100	0,1450	0,1020	7,5006
1 x 10 ⁵	100,0000	1,000	14,5038	10,1972	750,0638
6894,7570	6,8948	0,0689	1,000	0,7031	51,7151
9806,6500	9,8067	0,0981	1,4223	1,000	73,5561
133,3220	0,1333	0,0013	0,0193	0,0136	1,000

LENGTH

millimetre mm	centimetre cm	metre m	inch in	foot ft	yard yd
1,000	0,1000	0,0010	0,0394	0,0033	0,0011
10,0000	1,000	0,0100	0,3937	0,0328	0,0109
1000,0000	100,0000	1,000	39,3701	3,2808	1,0936
25,4000	2,5400	0,0254	1,000	0,0833	0,0278
304,8000	30,4800	0,3048	12,0000	1,000	0,3333
914,4000	91,4400	0,9144	36,0000	3,0000	1,000

VOLUME

cubic metre m ³	litre litro	millilitre ml	imp. Gallon imp. gal.	US gallon US gal.	cubic foot ft ³
1,000	1000,0000	1 x 10 ⁶	219,9694	264,1720	35,3147
0,0010	1,000	1000,0000	0,2200	0,2642	0,0353
1 x 10 ⁻⁶	0,0010	1,000	2.2 x 10 ⁻⁴	2.642 x 10 ⁻⁴	3.53 x 10 ⁻⁵
0,0045	4,5461	4546,0870	1,000	1,2009	0,1605
0,0038	3,7854	3785,4120	0,8327	1,000	0,1337
0,0283	28,3168	28316,8466	6,2288	7,4805	1,000

G-at_pp-en_a_sc

FURTHER PRODUCT SELECTION AND DOCUMENTATION

Xylect

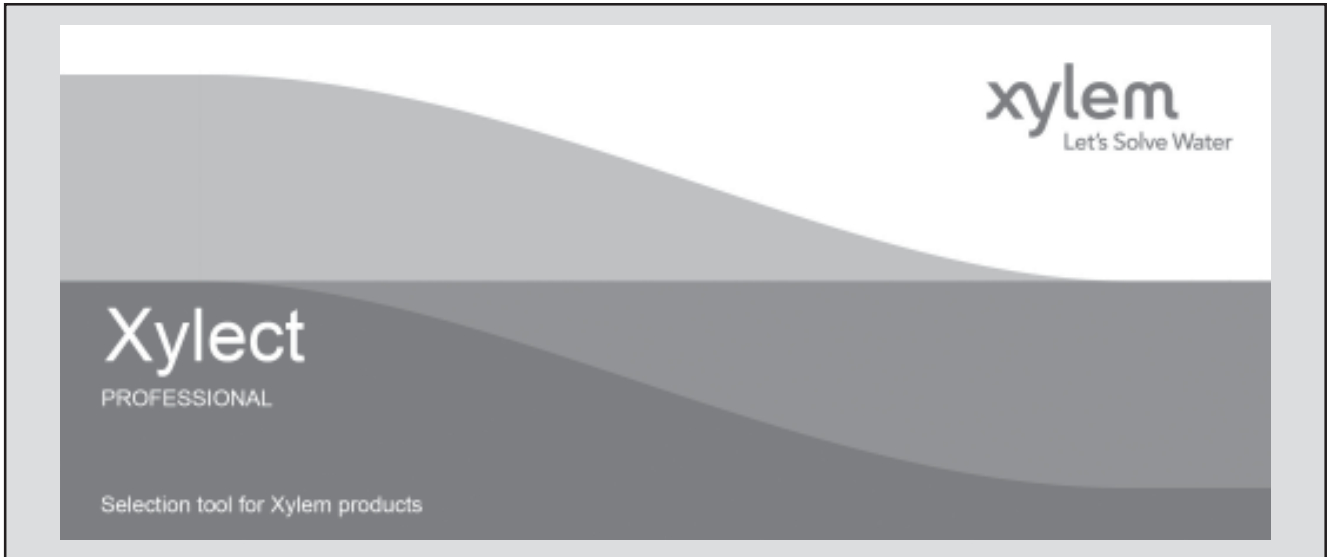

Xylect is pump solution selection software with an extensive online database of product information across the entire Lowara, and Vogel range of pumps and related products, with multiple search options and helpful project management facilities. The system holds up-to-date product information on thousands of products and accessories.

The possibility to search by applications and the detailed information output given makes it easy to make the optimal selection without having detailed knowledge about the Lowara and Vogel products.

The search can be made by:

- Application
- Product type
- Duty point

Xylect gives a detailed output:

- List with search results
- Performance curves (flow, head, power, efficiency, NPSH)
- Motor data
- Dimensional drawings
- Options
- Data sheet printouts
- Document downloads incl dxf files

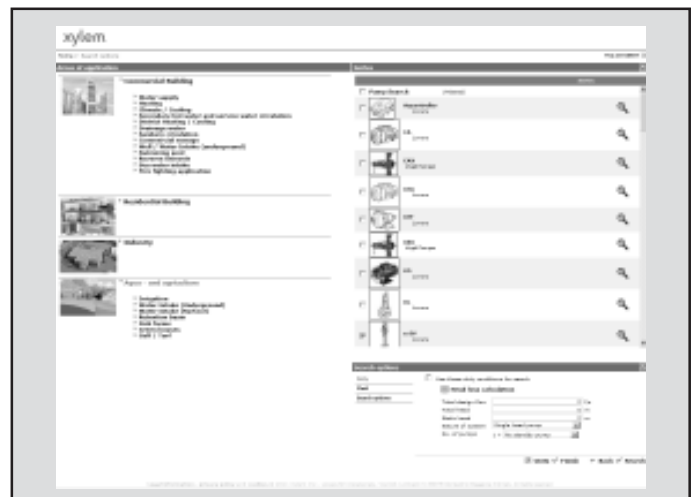

The search by application guides users not familiar with the product range to the right choice.

FURTHER PRODUCT SELECTION AND DOCUMENTATION

Xylect

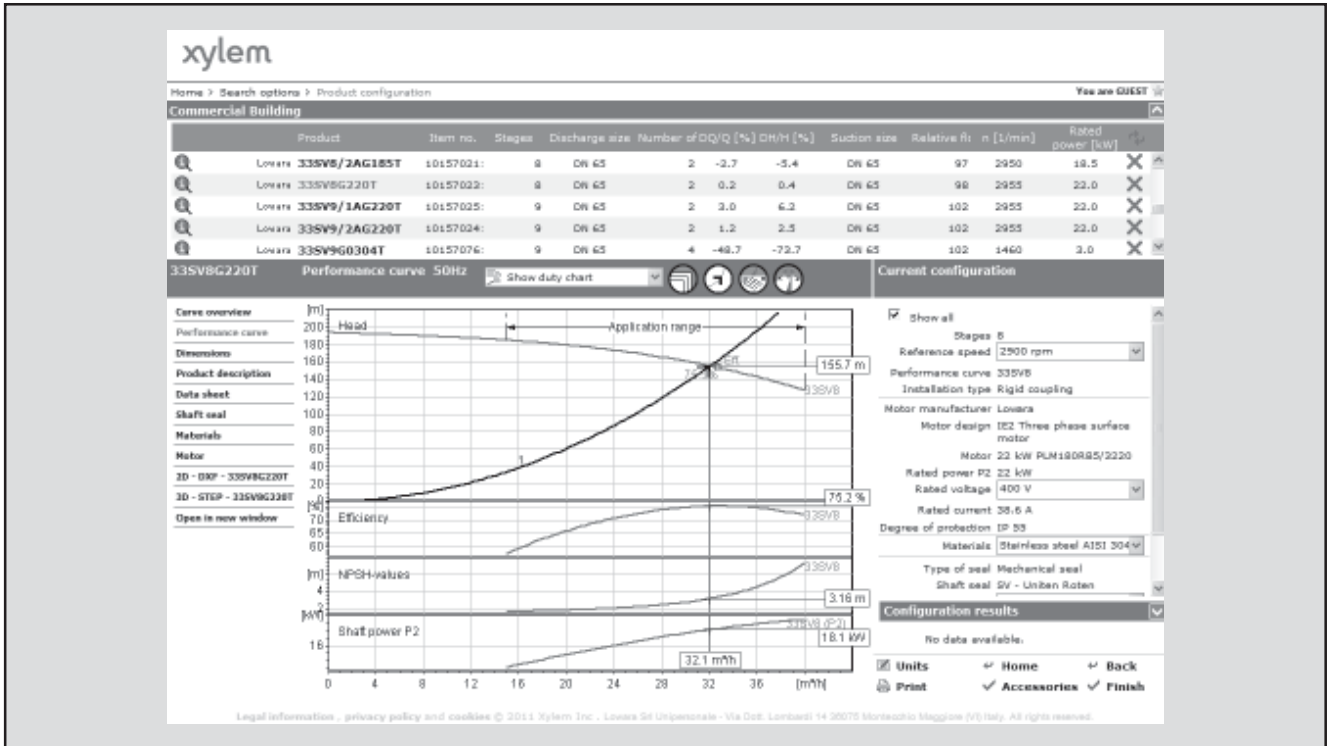

The detailed output makes it easy to select the optimal pump from the given alternatives.

The best way to work with Xylect is to create a personal account. This makes it possible to:

- Set own standard units
- Create and save projects
- Share projects with other Xylect users

Every user have a My Xylect space, where all projects are saved.

For more information about Xylect please contact our sales network or visit www.xylect.com.

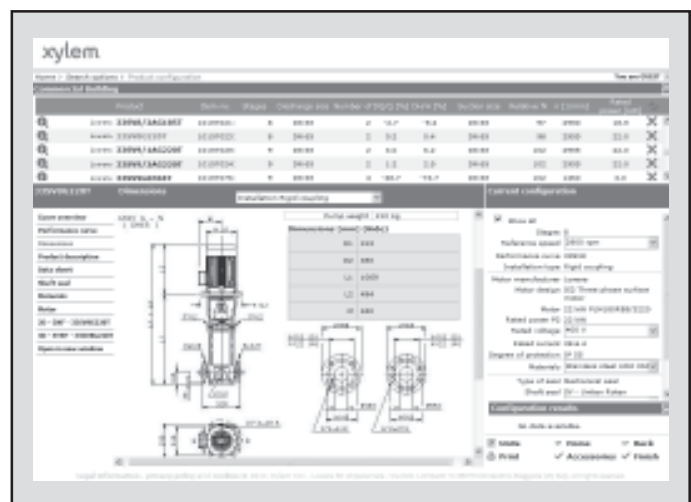

Dimensional drawings appear on the screen and can be downloaded in dxf format.

BOOSTER SETS, GS SERIES WITH ELECTRIC PUMPS CA ELECTRICAL DATA AT 50 Hz, 2 POLES

PUMP TYPE	MOTOR TYPE	INPUT POWER*	INPUT CURRENT*		CAPACIT.	PUMP TYPE	MOTOR TYPE	INPUT POWER*	INPUT CURRENT*	
			220-240 V						220-240 V	380-415 V
1~		kW	A	μF / 450 V			kW	A	A	
CAM70/33	SM71CA/1075	1,15	5,16	20	CA70/33	SM80CA/307PE	1,06	3,24	1,87	
CAM70/34	SM71CA/1095	1,39	6,22	25	CA70/34	SM80CA/311PE	1,28	4,10	2,37	
CAM70/45	SM80CA/1115	1,76	7,92	30	CA70/45	SM80CA/311PE	1,63	4,90	2,83	
CAM120/33	SM80CA/1115	1,67	7,53	30	CA120/33	SM80CA/311PE	1,54	4,69	2,71	
CAM120/35	SM80CA/1155	2,18	9,87	40	CA120/35	SM80CA/315PE	2,01	6,11	3,53	
CAM120/55	PLM90CA/1225	2,54	11,5	70	CA120/55	PLM90CA/322	2,55	8,05	4,65	
CAM200/33	PLM90CA/1225	2,29	10,4	70	CA200/33	PLM90CA/322	2,26	7,47	4,31	
CAM200/35	PLM90CA/1225	2,94	12,6	70	CA200/35	PLM90CA/322	3,02	9,08	5,24	
-	-	-	-	-	CA200/55	PLM90CA/330	3,51	10,7	6,18	

*Maximum value in specified range.

ca-2p50-en_f_te

THREE-PHASE MOTORS AT 50 Hz, 2 POLES

P _N kW	Efficiency η _N																		IE	Year of manufacture
	%																			
	Δ 220 V Y 380 V			Δ 230 V Y 400 V			Δ 240 V Y 415 V			Δ 380 V Y 660 V			Δ 400 V Y 690 V			Δ 415 V				
	4/4	3/4	2/4	4/4	3/4	2/4	4/4	3/4	2/4	4/4	3/4	2/4	4/4	3/4	2/4	4/4	3/4	2/4		
0,75	82,5	83,1	81,3	82,8	82,7	80,1	82,6	82,0	78,9	82,5	82,0	78,9	82,5	82,0	78,9	82,5	82,0	78,9		
0,9	84,0	84,7	83,4	84,4	84,5	82,5	84,3	84,0	81,4	84,0	84,0	81,4	84,0	84,0	81,4	84,0	84,0	81,4	3	By June 2011
1,1	84,0	84,7	83,4	84,4	84,5	82,5	84,3	84,0	81,4	84,0	84,0	81,4	84,0	84,0	81,4	84,0	84,0	81,4		
1,5	85,6	86,5	85,8	85,9	86,4	84,9	86,0	86,0	84,0	85,6	86,0	84,0	85,6	86,0	84,0	85,6	86,0	84,0		
1,85	83,7	83,7	83,7	83,7	83,7	83,7	83,7	83,7	83,7	83,7	83,7	83,7	83,7	83,7	83,7	83,7	83,7	83,7		
2,2	83,7	83,7	83,7	83,7	83,7	83,7	83,7	83,7	83,7	83,7	83,7	83,7	83,7	83,7	83,7	83,7	83,7	83,7	2	
3	85,5	86,8	85,6	86,1	86,8	85,6	86,3	86,8	85,6	85,5	86,8	85,6	85,5	86,8	85,6	85,5	86,8	85,6		

P _N kW	Manufacturer		IEC SIZE	Construction Design	N. of Poles	f _N Hz	Data for 400 V / 50 Hz Voltage				
	Lowara srl Unipersonale Reg. No. 341820260 Montecchio Maggiore Vicenza - Italia						cosφ	I _s / I _N	T _N Nm	T _s /T _N	T _m /T _N
	Model										
0,75	SM80CA/307PE		80	SPECIAL	2	50	0,78	7,38	2,48	3,57	3,75
0,9	SM80CA/311PE		80				0,79	8,31	3,63	3,95	3,95
1,1	SM80CA/311PE		80				0,79	8,31	3,63	3,95	3,95
1,5	SM80CA/315PE		80				0,80	8,80	4,96	4,31	4,10
1,85	PLM90BG/322		90				0,80	8,63	7,25	3,74	3,71
2,2	PLM90BG/322		90				0,80	8,63	7,25	3,74	3,71
3	PLM90BG/330		90				0,82	8,39	9,96	3,50	3,32

P _N kW	Voltage U _N											n _N min ⁻¹	See note:	Operating conditions **		
	Δ						Y							Altitude Above Sea Level (m)	T. amb min/max °C	ATEX
	220 V	230 V	240 V	380 V	400 V	415 V	380 V	400 V	415 V	660 V	690 V					
0,75	2,96	2,94	2,96	1,71	1,70	1,71	1,70	1,69	1,70	0,98	0,98	2875 ÷ 2895	≤ 1000	-15 / 40	No	
0,9	4,19	4,14	4,16	2,42	2,39	2,40	2,41	2,38	2,38	1,39	1,37	2870 ÷ 2900				
1,1	4,19	4,14	4,16	2,42	2,39	2,40	2,41	2,38	2,38	1,39	1,37	2870 ÷ 2900				
1,5	5,56	5,49	5,51	3,21	3,17	3,18	3,21	3,18	3,19	1,85	1,84	2870 ÷ 2895				
1,85	8,05	8,04	8,09	4,65	4,64	4,67	4,62	4,61	4,63	2,67	2,66	2885 ÷ 2900				
2,2	8,05	8,04	8,09	4,65	4,64	4,67	4,62	4,61	4,63	2,67	2,66	2885 ÷ 2900				
3	10,8	10,6	10,6	6,23	6,14	6,12	6,18	6,10	6,06	3,57	3,52	2850 ÷ 2885				

Note: Observe the regulations and codes locally in force regarding sorted waste disposal.

ca-ie2-mott-2p50-en_c_te

** Operating conditions to be referred to motor only. About electric pump, refer to limits in user's manual.

BOOSTER SETS, GS SERIES WITH ELECTRIC PUMPS e-SV™ THREE-PHASE MOTORS AT 50 Hz, 2 POLES (up to 22 kW)

P _N kW	Efficiency η _N %																		IE	Year of manufacture							
	Δ 220 V Y 380 V			Δ 230 V Y 400 V			Δ 240 V Y 415 V			Δ 380 V Y 660 V			Δ 400 V Y 690 V			Δ 415 V											
	4/4	3/4	2/4	4/4	3/4	2/4	4/4	3/4	2/4	4/4	3/4	2/4	4/4	3/4	2/4	4/4	3/4	2/4									
0,37	-	-	-	-	-	-	-	-	-	-	-	-	-	-	-	-	-	-	-	-	-	-	-	-	-		
0,55	-	-	-	-	-	-	-	-	-	-	-	-	-	-	-	-	-	-	-	-	-	-	-	-	-		
0,75	82,5	83,1	81,3	82,8	82,7	80,1	82,6	82,0	78,9	82,5	82,0	78,9	82,5	82,0	78,9	82,5	82,0	78,9	82,5	82,0	78,9	82,5	82,0	78,9	3	By June 2011	
1,1	84,0	84,7	83,4	84,4	84,5	82,5	84,3	84,0	81,4	84,0	84,0	81,4	84,0	84,0	81,4	84,0	84,0	81,4	84,0	84,0	81,4	84,0	84,0	81,4	2		
1,5	85,6	86,5	85,8	85,9	86,4	84,9	86,0	86,0	84,0	85,6	86,0	84,0	85,6	86,0	84,0	85,6	86,0	84,0	85,6	86,0	84,0	85,6	86,0	84,0	2		
2,2	83,7	83,7	83,7	83,7	83,7	83,7	83,7	83,7	83,7	83,7	83,7	83,7	83,7	83,7	83,7	83,7	83,7	83,7	83,7	83,7	83,7	83,7	83,7	83,7	2		
3	85,5	86,8	85,6	86,1	86,8	85,6	86,3	86,8	85,6	85,5	86,8	85,6	85,5	86,8	85,6	85,5	86,8	85,6	85,5	86,8	85,6	85,5	86,8	85,6	2		
4	86,3	86,3	86,3	86,3	86,3	86,3	86,3	86,3	86,3	86,3	86,3	86,3	86,3	86,3	86,3	86,3	86,3	86,3	86,3	86,3	86,3	86,3	86,3	86,3	2		
5,5	87,6	87,6	87,6	87,6	87,6	87,6	87,6	87,6	87,6	87,6	87,6	87,6	87,6	87,6	87,6	87,6	87,6	87,6	87,6	87,6	87,6	87,6	87,6	87,6	2		
7,5	88,6	88,1	88,1	88,6	88,1	88,1	88,6	88,1	88,1	88,6	88,1	88,1	88,6	88,1	88,1	88,6	88,1	88,1	88,6	88,1	88,1	88,6	88,1	88,1	2		
11	90,3	91,1	90,3	90,3	91,1	90,3	90,3	91,1	90,3	90,3	91,1	90,3	90,8	91,1	90,3	91,0	91,1	90,3	91,0	91,1	90,3	91,0	91,1	90,3	2		
15	90,3	90,3	90,3	90,3	90,3	90,3	90,3	90,3	90,3	90,3	90,3	90,3	90,3	90,3	90,3	90,3	90,3	90,3	90,3	90,3	90,3	90,3	90,3	90,3	2		
18,5	91,2	91,2	91,2	91,2	91,2	91,2	91,2	91,2	91,2	91,2	91,2	91,2	91,2	91,2	91,2	91,2	91,2	91,2	91,2	91,2	91,2	91,2	91,2	91,2	2		
22	91,3	91,3	91,3	91,3	91,3	91,3	91,3	91,3	91,3	91,3	91,3	91,3	91,3	91,3	91,3	91,3	91,3	91,3	91,3	91,3	91,3	91,3	91,3	91,3	2		

P _N kW	Manufacturer		IEC SIZE*	Construction Design	N. of Poles	f _N Hz	Data for 400 V / 50 Hz Voltage				
	Lowara srl Unipersonale Reg. No. 341820260 Montecchio Maggiore Vicenza - Italia						cosφ	I _s / I _N	T _N Nm	Ts/T _N	Tm/Tn
	Model										
0,37	SM71RB14/304		71R	V18/B14	2	50	0,66	4,32	1,38	4,14	3,13
0,55	SM71B14/305		71				0,74	5,97	1,85	3,74	3,56
0,75	SM80B14/307PE		80				0,78	7,38	2,48	3,57	3,75
1,1	SM80B14/311PE		80				0,79	8,31	3,63	3,95	3,95
1,5	SM90RB14/315PE		90R				0,80	8,80	4,96	4,31	4,10
2,2	PLM90B14/322		90				0,80	8,63	7,25	3,74	3,71
3	PLM100RB14/330		100R				0,82	8,39	9,96	3,50	3,32
4	PLM112RB14/340		112R				0,85	9,52	13,1	3,04	4,40
5,5	PLM132RB5/355		132R				0,87	10,3	18,1	4,43	5,80
7,5	PLM132B5/375		132				0,87	9,21	24,5	3,26	4,55
11	PLM160RB5/3110		160R				0,87	9,72	36,0	3,46	4,56
15	PLM160B5/3150		160				0,91	8,45	48,6	2,26	3,81
18,5	PLM160B5/3185		160				0,88	9,75	59,8	2,82	4,53
22	PLM180RB5/3220		180R				0,89	9,50	71,1	2,74	4,26

P _N kW	Voltage U _N V											n _N min ⁻¹	Observe the regulations and codes locally in force regarding sorted waste disposal.	Operating conditions **		
	Δ			Y			Δ			Y				Altitude Above Sea Level (m)	T. amb min/max °C	ATEX
	220 V	230 V	240 V	380 V	400 V	415 V	380 V	400 V	415 V	660 V	690 V					
0,37	2,20	2,34	2,51	1,27	1,35	1,45	-	-	-	-	-	2740 ÷ 2790	≤ 1000	-15 / 40	No	
0,55	2,56	2,56	2,62	1,48	1,48	1,51	-	-	-	-	-	2825 ÷ 2850				
0,75	2,96	2,94	2,96	1,71	1,70	1,71	1,70	1,69	1,70	0,98	0,98	2875 ÷ 2895				
1,1	4,19	4,14	4,16	2,42	2,39	2,40	2,41	2,38	2,38	1,39	1,37	2870 ÷ 2900				
1,5	5,56	5,49	5,51	3,21	3,17	3,18	3,21	3,18	3,19	1,85	1,84	2870 ÷ 2895				
2,2	8,05	8,04	8,09	4,65	4,64	4,67	4,62	4,61	4,63	2,67	2,66	2885 ÷ 2900				
3	10,8	10,6	10,6	6,23	6,14	6,12	6,18	6,10	6,06	3,57	3,52	2850 ÷ 2885				
4	13,6	13,5	13,5	7,88	7,77	7,79	7,80	7,63	7,65	4,51	4,41	2895 ÷ 2920				
5,5	18,3	18,0	17,9	10,6	10,4	10,3	10,6	10,4	10,5	6,14	6,02	2885 ÷ 2905				
7,5	25,4	24,8	24,4	14,7	14,3	14,1	14,5	14,0	13,9	8,35	8,11	2920 ÷ 2935				
11	36,0	35,1	34,7	20,8	20,3	20,0	20,8	20,3	20,1	12,0	11,7	2910 ÷ 2925				
15	47,2	45,3	44,0	27,2	26,2	25,4	27,2	26,0	25,3	15,7	15,0	2940 ÷ 2950				
18,5	58,3	56,9	55,9	33,7	32,9	32,3	34,1	33,2	32,8	19,7	19,1	2945 ÷ 2955				
22	68,3	66,2	64,3	39,4	38,2	37,1	40,0	38,6	37,8	23,1	22,3	2945 ÷ 2955				

* R = Reduced size of motor casing as compared to shaft extension and flange.

sv-ie2-mott22-2p50-en_c_tte

** Operating conditions to be referred to motor only. About electric pump, refer to limits in user's manual.

BOOSTER SETS, GS SERIES WITH ELECTRIC PUMPS FHE THREE-PHASE MOTORS AT 50 Hz, 2 POLES (up to 22 kW)

P _N kW	Efficiency η_N %																		IE	Year of manufacture
	Δ 220 V Y 380 V			Δ 230 V Y 400 V			Δ 240 V Y 415 V			Δ 380 V Y 660 V			Δ 400 V Y 690 V			Δ 415 V				
	4/4	3/4	2/4	4/4	3/4	2/4	4/4	3/4	2/4	4/4	3/4	2/4	4/4	3/4	2/4	4/4	3/4	2/4		
0,75	82,5	83,1	81,3	82,8	82,7	80,1	82,6	82,0	78,9	82,5	82,0	78,9	82,5	82,0	78,9	82,5	82,0	78,9	3	By June 2011
1,1	84,0	84,7	83,4	84,4	84,5	82,5	84,3	84,0	81,4	84,0	84,0	81,4	84,0	84,0	81,4	84,0	84,0	81,4		
1,5	85,6	86,5	85,8	85,9	86,4	84,9	86,0	86,0	84,0	85,6	86,0	84,0	85,6	86,0	84,0	85,6	86,0	84,0		
2,2	83,7	83,7	83,7	83,7	83,7	83,7	83,7	83,7	83,7	83,7	83,7	83,7	83,7	83,7	83,7	83,7	83,7	83,7		
3	85,5	86,8	85,6	86,1	86,8	85,6	86,3	86,8	85,6	85,5	86,8	85,6	85,5	86,8	85,6	85,5	86,8	85,6		
4	86,3	86,3	86,3	86,3	86,3	86,3	86,3	86,3	86,3	86,3	86,3	86,3	86,3	86,3	86,3	86,3	86,3	86,3		
5,5	87,6	87,6	87,6	87,6	87,6	87,6	87,6	87,6	87,6	87,6	87,6	87,6	87,6	87,6	87,6	87,6	87,6	87,6		
7,5	88,6	88,1	88,1	88,6	88,1	88,1	88,6	88,1	88,1	88,6	88,1	88,1	88,6	88,1	88,1	88,6	88,1	88,1		
9,2	89,3	88,8	88,8	89,3	88,8	88,8	89,3	88,8	88,8	89,3	88,8	88,8	89,3	88,8	88,8	89,3	88,8	88,8		
11	90,3	91,1	90,3	90,3	91,1	90,3	90,3	91,1	90,3	90,3	91,1	90,3	90,3	90,8	91,1	90,3	91,0	91,1		
15	90,3	90,3	90,3	90,3	90,3	90,3	90,3	90,3	90,3	90,3	90,3	90,3	90,3	90,3	90,3	90,3	90,3	90,3		
18,5	91,2	91,2	91,2	91,2	91,2	91,2	91,2	91,2	91,2	91,2	91,2	91,2	91,2	91,2	91,2	91,2	91,2	91,2		
22	91,3	91,3	91,3	91,3	91,3	91,3	91,3	91,3	91,3	91,3	91,3	91,3	91,3	91,3	91,3	91,3	91,3	91,3		

P _N kW	Manufacturer		IEC SIZE*	Construction Design	N. of Poles	f _N Hz	Data for 400 V / 50 Hz Voltage				
	Lowara srl Unipersonale Reg. No. 341820260 Montecchio Maggiore Vicenza - Italia						cos ϕ	I _s / I _N	T _N Nm	T _s /T _N	T _m /T _N
	Model										
0,75	SM90RB14S/307PE		90R	SPECIAL	2	50	0,78	7,38	2,48	3,57	3,75
1,1	SM90RB14S/311PE		90R				0,79	8,31	3,63	3,95	3,95
1,5	SM90RB14S/315PE		90R				0,80	8,80	4,96	4,31	4,10
2,2	PLM90B14S/322		90				0,80	8,63	7,25	3,74	3,71
3	PLM90B14S/330		90				0,82	8,39	9,96	3,50	3,32
4	PLM112RB14S/340		112R				0,85	9,52	13,1	3,04	4,40
5,5	PLM112B14S/355		112				0,87	10,3	18,1	4,43	5,80
7,5	PLM132B14S/375		132				0,87	9,21	24,5	3,26	4,55
9,2	PLM132B14S/392		132				0,88	9,66	30,0	3,17	4,54
11	PLM132B14S/3110		132				0,87	9,72	36,0	3,46	4,56
15	PLM160B34S/3150		160				0,91	8,45	48,6	2,26	3,81
18,5	PLM160B34S/3185		160				0,88	9,75	59,8	2,82	4,53
22	PLM160B34S/3220		160	0,89	9,50	71,1	2,74	4,26			

P _N kW	Voltage U _N V										n _N min ⁻¹	Observe the regulations and codes locally in force regarding sorted waste disposal.	Operating conditions **				
	Δ			Y			Δ			Y			Altitude Above Sea Level (m)	T. amb min/max °C	ATEX		
	220 V	230 V	240 V	380 V	400 V	415 V	380 V	400 V	415 V	660 V						690 V	I _N (A)
0,75	2,96	2,94	2,96	1,71	1,70	1,71	1,70	1,69	1,70	0,98	0,98	2875 ÷ 2895	≤ 1000	-15 / 40	No		
1,1	4,19	4,14	4,16	2,42	2,39	2,40	2,41	2,38	2,38	1,39	1,37	2870 ÷ 2900					
1,5	5,56	5,49	5,51	3,21	3,17	3,18	3,21	3,18	3,19	1,85	1,84	2870 ÷ 2895					
2,2	8,05	8,04	8,09	4,65	4,64	4,67	4,62	4,61	4,63	2,67	2,66	2885 ÷ 2900					
3	10,8	10,6	10,6	6,23	6,14	6,12	6,18	6,10	6,06	3,57	3,52	2850 ÷ 2885					
4	13,6	13,5	13,5	7,88	7,77	7,79	7,80	7,63	7,65	4,51	4,41	2895 ÷ 2920					
5,5	18,3	18,0	17,9	10,6	10,4	10,3	10,6	10,4	10,5	6,14	6,02	2885 ÷ 2905					
7,5	25,4	24,8	24,4	14,7	14,3	14,1	14,5	14,0	13,9	8,35	8,11	2920 ÷ 2935					
9,2	29,7	28,9	28,3	17,2	16,7	16,4	17,3	16,8	16,6	10,0	9,70	2910 ÷ 2930					
11	36,0	35,1	34,7	20,8	20,3	20,0	20,8	20,3	20,1	12,0	11,7	2910 ÷ 2925					
15	47,2	45,3	44,0	27,2	26,2	25,4	27,2	26,0	25,3	15,7	15,0	2940 ÷ 2950					
18,5	58,3	56,9	55,9	33,7	32,9	32,3	34,1	33,2	32,8	19,7	19,1	2945 ÷ 2955					
22	68,3	66,2	64,3	39,4	38,2	37,1	40,0	38,6	37,8	23,1	22,3	2945 ÷ 2955					

* R = Reduced size of motor casing as compared to shaft extension and flange.

** Operating conditions to be referred to motor only. About electric pump, refer to limits in user's manual.

BOOSTER SETS, GS SERIES WITH ELECTRIC PUMPS FHS THREE-PHASE MOTORS AT 50 Hz, 2 POLES (from 22 to 132 kW)

P _N kW	Efficiency η_N %									IE	Year of manufacture
	Δ 380 V Y 660 V			Δ 400 V Y 690 V			Δ 415 V				
	4/4	3/4	2/4	4/4	3/4	2/4	4/4	3/4	2/4		
22	91,8	92,2	92,2	92,0	92,4	92,2	92,4	92,4	91,8	2	By June 2011
30	92,6	92,9	92,7	92,5	93,0	92,9	93,0	93,0	92,3		
37	93,0	93,3	93,2	93,0	93,4	93,3	93,5	93,4	92,8		
45	93,2	93,5	93,4	93,3	93,6	93,6	93,8	93,6	93,1		
55	93,6	93,8	93,8	93,6	93,9	93,9	94,0	93,8	93,3		
75	94,1	94,3	93,6	93,4	94,3	94,3	94,3	94,2	93,2		
90	94,4	94,6	94,2	94,0	94,6	94,6	94,5	94,5	93,8		
110	94,8	94,9	94,5	94,3	94,9	94,9	94,9	94,8	94,1		
132	94,9	95,1	94,6	94,5	95,1	95,1	95,2	95,1	94,4		

P _N kW	Manufacturer		IEC SIZE	Construction Design	N. of Poles	f _N Hz	Data for 400 V / 50 Hz Voltage				
	WEG Equipamentos Eletricos S.A. Reg. No. 07.175.725/0010-50 Jaragua do Sul - SC (Brazil)						cos ϕ	I _s / I _N	T _N Nm	T _s /T _N	T _m /T _N
	Model										
22	W22 180M2-B3	22kW	180	B3	2	50	0,88	7,30	71,40	2,20	3,00
30	W22 200L2-B3 (B35)	30kW	200	B3 / B35			0,87	6,50	97,00	2,40	2,70
37	W22 200L2-B3 (B35)	37kW	200				0,87	6,80	120,0	2,40	2,60
45	W22 225S/M2-B3 (B35)	45kW	225				0,89	7,00	145,0	2,20	2,80
55	W22 250S/M2-B3 (B35)	55kW	250	0,89			7,00	178,0	2,20	2,80	
75	W22 280S/M2-B3	75kW	280	0,89			7,00	241,0	2,00	2,80	
90	W22 280S/M2-B3	90kW	280	0,89			7,00	289,0	2,00	2,80	
110	W22 315S/M2-B3	110kW	315	B3			0,89	7,30	353,0	2,00	2,90
132	W22 315S/M2-B3	132kW	315				0,90	7,30	423,0	2,00	2,90

P _N kW	Voltage U _N V					n _N min ⁻¹	Operating conditions **			
	Δ			Y			See note.	Altitude Above Sea Level (m)	T. amb min/max °C	ATEX
	380 V	400 V	415 V	660 V	690 V					
	I _N (A)									
22	40,90	39,10	38,10	23,55	22,67	2940 ÷ 2950	≤ 1000	-15 / 40	No	
30	55,90	53,60	52,20	32,18	31,07	2950 ÷ 2960				
37	68,70	65,80	64,00	39,55	38,14	2945 ÷ 2955				
45	81,50	78,00	75,80	46,92	45,22	2955 ÷ 2960				
55	99,20	95,00	92,50	57,12	55,07	2955 ÷ 2960				
75	135,00	129,00	126,00	77-73	74,78	2970 ÷ 2975				
90	161,00	154,00	151,00	92,70	89,28	2970 ÷ 2975				
110	196,00	188,00	183,00	112,85	108,99	2975 ÷ 2980				
132	232,00	223,00	217,00	133,58	129,28	2975 ÷ 2980				

** Operating conditions to be referred to motor only. About electric pump, refer to limits in user's manual.

fhh-ie2-mott132-2p50-en_a_te

Note: Observe the regulations and codes locally in force regarding sorted waste disposal.

BOOSTER SETS, GS SERIES WITH ELECTRIC PUMPS SHE THREE-PHASE MOTORS AT 50 Hz, 2 POLES (up to 22 kW)

P _N kW	Efficiency η_N %																		IE	Year of manufacture
	Δ 220 V Y 380 V			Δ 230 V Y 400 V			Δ 240 V Y 415 V			Δ 380 V Y 660 V			Δ 400 V Y 690 V			Δ 415 V				
	4/4	3/4	2/4	4/4	3/4	2/4	4/4	3/4	2/4	4/4	3/4	2/4	4/4	3/4	2/4	4/4	3/4	2/4		
0,75	82,5	83,1	81,3	82,8	82,7	80,1	82,6	82,0	78,9	82,5	82,0	78,9	82,5	82,0	78,9	82,5	82,0	78,9	3	By June 2011
1,1	84,0	84,7	83,4	84,4	84,5	82,5	84,3	84,0	81,4	84,0	84,0	81,4	84,0	84,0	81,4	84,0	84,0	81,4		
1,5	85,6	86,5	85,8	85,9	86,4	84,9	86,0	86,0	84,0	85,6	86,0	84,0	85,6	86,0	84,0	85,6	86,0	84,0		
2,2	83,7	83,7	83,7	83,7	83,7	83,7	83,7	83,7	83,7	83,7	83,7	83,7	83,7	83,7	83,7	83,7	83,7	83,7	2	
3	85,5	86,8	85,6	86,1	86,8	85,6	86,3	86,8	85,6	85,5	86,8	85,6	85,5	86,8	85,6	85,5	86,8	85,6		
4	86,3	86,3	86,3	86,3	86,3	86,3	86,3	86,3	86,3	86,3	86,3	86,3	86,3	86,3	86,3	86,3	86,3	86,3		
5,5	87,6	87,6	87,6	87,6	87,6	87,6	87,6	87,6	87,6	87,6	87,6	87,6	87,6	87,6	87,6	87,6	87,6	87,6		
7,5	88,6	88,1	88,1	88,6	88,1	88,1	88,6	88,1	88,1	88,6	88,1	88,1	88,6	88,1	88,1	88,6	88,1	88,1		
9,2	89,3	88,8	88,8	89,3	88,8	88,8	89,3	88,8	88,8	89,3	88,8	88,8	89,3	88,8	88,8	89,3	88,8	88,8		
11	90,3	91,1	90,3	90,3	91,1	90,3	90,3	91,1	90,3	90,3	91,1	90,3	90,3	90,8	91,1	90,3	91,0	91,1		
15	90,3	90,3	90,3	90,3	90,3	90,3	90,3	90,3	90,3	90,3	90,3	90,3	90,3	90,3	90,3	90,3	90,3	90,3		
18,5	91,2	91,2	91,2	91,2	91,2	91,2	91,2	91,2	91,2	91,2	91,2	91,2	91,2	91,2	91,2	91,2	91,2	91,2		
22	91,3	91,3	91,3	91,3	91,3	91,3	91,3	91,3	91,3	91,3	91,3	91,3	91,3	91,3	91,3	91,3	91,3	91,3		

P _N kW	Manufacturer		IEC SIZE*	Construction Design	N. of Poles	f _N Hz	Data for 400 V / 50 Hz Voltage				
	Lowara srl Unipersonale Reg. No. 341820260 Montecchio Maggiore Vicenza - Italia						cos ϕ	I _s / I _N	T _N Nm	T _s /T _N	T _m /T _N
	Model										
0,75	SM90RB14S/307PE		90R	SPECIAL	2	50	0,78	7,38	2,48	3,57	3,75
1,1	SM90RB14S/311PE		90R				0,79	8,31	3,63	3,95	3,95
1,5	SM90RB14S/315PE		90R				0,80	8,80	4,96	4,31	4,10
2,2	PLM90B14S/322		90				0,80	8,63	7,25	3,74	3,71
3	PLM90B14S/330		90				0,82	8,39	9,96	3,50	3,32
4	PLM112RB14S/340		112R				0,85	9,52	13,1	3,04	4,40
5,5	PLM112B14S/355		112				0,87	10,3	18,1	4,43	5,80
7,5	PLM132B14S/375		132				0,87	9,21	24,5	3,26	4,55
9,2	PLM132B14S/392		132				0,88	9,66	30,3	3,17	4,54
11	PLM132B14S/3110		132				0,87	9,72	36,0	3,46	4,56
15	PLM160B34S/3150		160				0,91	8,45	48,6	2,26	3,81
18,5	PLM160B34S/3185		160				0,88	9,75	59,8	2,82	4,53
22	PLM160B34S/3220		160	0,89	9,50	71,1	2,74	4,26			

P _N kW	Voltage U _N V										n _N min ⁻¹	Observe the regulations and codes locally in force regarding sorted waste disposal.	Operating conditions **			
	Δ			Y			Δ			Y			Altitude Above Sea Level (m)	T. amb min/max °C	ATEX	
	220 V	230 V	240 V	380 V	400 V	415 V	380 V	400 V	415 V	660 V						690 V
0,75	2,96	2,94	2,96	1,71	1,70	1,71	1,70	1,69	1,70	0,98	0,98	2875 ÷ 2895	≤ 1000	-15 / 40	No	
1,1	4,19	4,14	4,16	2,42	2,39	2,40	2,41	2,38	2,38	1,39	1,37	2870 ÷ 2900				
1,5	5,56	5,49	5,51	3,21	3,17	3,18	3,21	3,18	3,19	1,85	1,84	2870 ÷ 2895				
2,2	8,05	8,04	8,09	4,65	4,64	4,67	4,62	4,61	4,63	2,67	2,66	2885 ÷ 2900				
3	10,8	10,6	10,6	6,23	6,14	6,12	6,18	6,10	6,06	3,57	3,52	2850 ÷ 2885				
4	13,6	13,5	13,5	7,88	7,77	7,79	7,80	7,63	7,65	4,51	4,41	2895 ÷ 2920				
5,5	18,3	18,0	17,9	10,6	10,4	10,3	10,6	10,4	10,5	6,14	6,02	2885 ÷ 2905				
7,5	25,4	24,8	24,4	14,7	14,3	14,1	14,5	14,0	13,9	8,35	8,11	2920 ÷ 2935				
9,2	29,7	28,9	28,3	17,2	16,7	16,4	17,3	16,8	16,6	10,0	9,70	2910 ÷ 2930				
11	36,0	35,1	34,7	20,8	20,3	20,0	20,8	20,3	20,1	12,0	11,7	2910 ÷ 2925				
15	47,2	45,3	44,0	27,2	26,2	25,4	27,2	26,0	25,3	15,7	15,0	2940 ÷ 2950				
18,5	58,3	56,9	55,9	33,7	32,9	32,3	34,1	33,2	32,8	19,7	19,1	2945 ÷ 2955				
22	68,3	66,2	64,3	39,4	38,2	37,1	40,0	38,6	37,8	23,1	22,3	2945 ÷ 2955				

* R = Reduced size of motor casing as compared to shaft extension and flange.

** Operating conditions to be referred to motor only. About electric pump, refer to limits in user's manual.

BOOSTER SETS, GS SERIES WITH ELECTRIC PUMPS SHS THREE-PHASE MOTORS AT 50 Hz, 2 POLES (from 22 to 75 kW)

P _N kW	Efficiency η_N %									IE	Year of manufacture
	Δ 380 V Y 660 V			Δ 400 V Y 690 V			Δ 415 V				
	4/4	3/4	2/4	4/4	3/4	2/4	4/4	3/4	2/4		
22	91,8	92,2	92,2	92,0	92,4	92,2	92,4	92,4	91,8	2	By June 2011
30	92,6	92,9	92,7	92,5	93,0	92,9	93,0	93,0	92,3		
37	93,0	93,3	93,2	93,0	93,4	93,3	93,5	93,4	92,8		
45	93,2	93,5	93,4	93,3	93,6	93,6	93,8	93,6	93,1		
55	93,6	93,8	93,8	93,6	93,9	93,9	94,0	93,8	93,3		
75	94,1	94,3	93,6	93,4	94,3	94,3	94,3	94,2	93,2		

P _N kW	Manufacturer		IEC SIZE	Construction Design	N. of Poles	f _N Hz	Data for 400 V / 50 Hz Voltage				
	WEG Equipamentos Elétricos S.A. Reg. No. 07.175.725/0010-50 Jaraguá do Sul - SC (Brazil)						cos ϕ	I _s / I _N	T _N Nm	T _s /T _N	T _m /T _N
	Model										
22	W22 180M2-B3 22kW		180	B3	2	50	0,88	7,30	71,40	2,20	3,00
30	W22 200L2-B3 (B35) 30kW		200	B3			0,87	6,50	97,00	2,40	2,70
37	W22 200L2-B3 (B35) 37kW		200	B35			0,87	6,80	120,0	2,40	2,60
45	W22 225S/M2-B3 45kW		225	B3			0,89	7,00	145,0	2,20	2,80
55	W22 250S/M2-B3 55kW		250				0,89	7,00	178,0	2,20	2,80
75	W22 280S/M2-B3 75kW		280				0,89	7,00	241,0	2,00	2,80

P _N kW	Voltage U _N V					n _N min ⁻¹	See note.	Operating conditions **		
	Δ			Y				Altitude Above Sea Level (m)	T. amb min/max °C	ATEX
	380 V	400 V	415 V	660 V	690 V					
	I _N (A)									
22	40,90	39,10	38,10	23,55	22,67	2940 ÷ 2950	≤ 1000	-15 / 40	No	
30	55,90	53,60	52,20	32,18	31,07	2950 ÷ 2960				
37	68,70	65,80	64,00	39,55	38,14	2945 ÷ 2955				
45	81,50	78,00	75,80	46,92	45,22	2955 ÷ 2960				
55	99,20	95,00	92,50	57,12	55,07	2955 ÷ 2960				
75	135,00	129,00	126,00	77-73	74,78	2970 ÷ 2975				

** Operating conditions to be referred to motor only. About electric pump, refer to limits in user's manual.

shf-ie2-mott75-2p50-en_a_te

Note: Observe the regulations and codes locally in force regarding sorted waste disposal.

Xylem |'zīləm|

- 1) The tissue in plants that brings water upward from the roots;
- 2) a leading global water technology company.

We're 12,000 people unified in a common purpose: creating innovative solutions to meet our world's water needs. Developing new technologies that will improve the way water is used, conserved, and re-used in the future is central to our work. We move, treat, analyze, and return water to the environment, and we help people use water efficiently, in their homes, buildings, factories and farms. In more than 150 countries, we have strong, long-standing relationships with customers who know us for our powerful combination of leading product brands and applications expertise, backed by a legacy of innovation.

For more information on how Xylem can help you, go to xylem.com.

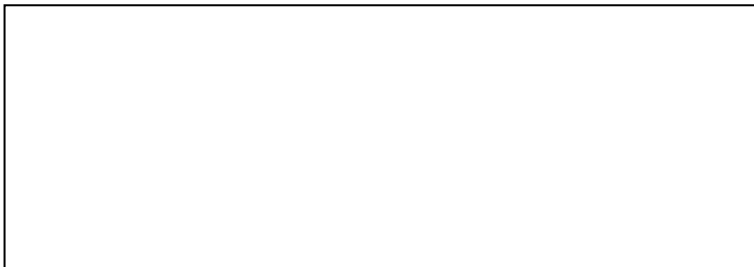

Headquarters

LOWARA S.r.l. Unipersonale
Via Vittorio Lombardi 14
36075 Montecchio Maggiore - Vicenza - Italy
Tel. (+39) 0444 707111 - Fax (+39) 0444 492166
e-mail: lowara.mkt@xylem.com
web: www.lowara.com - www.completewatersystems.com

LOWARA reserves the right to make modification without prior notice.
LOWARA is a trademark of Xylem Inc. or one of its subsidiaries.