

50 Hz

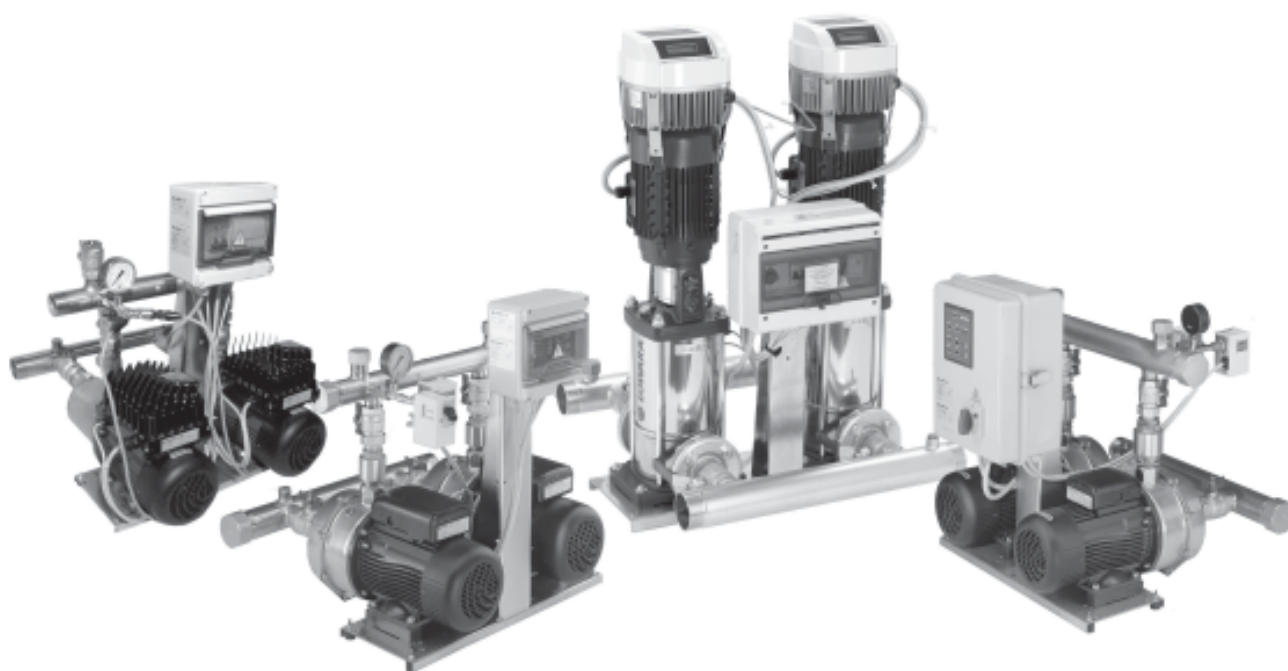

GXS-GMD-GTKS-GHV Series

TWO-PUMP BOOSTER SETS
FOR RESIDENTIAL MARKET, FLOW RATE UP TO 62 m³/h

CONTENTS

General introduction	3
Choice and selection	4
Description of operation	6
Range	9
Characteristics of the electric pumps	10
Hydraulic performance tables	14
Electric data tables	17
GXS20 series	19
GMD20 series	31
GTKS20 series	47
GHV20 series	59
Operating characteristics at 50 Hz	84
Operating characteristics at 30..50 Hz	104
Technical Appendix	125

TWO-PUMP BOOSTER SETS

GENERAL INTRODUCTION - PRODUCT DESCRIPTION

Lowara **GXS, GMD, GTKS** and **GHV** series booster sets are designed to transfer and increase the pressure of water, in the following applications:

- Public buildings
- Apartment
- Single house
- Condominiums
- Garden irrigation

The booster sets GXS, GMD, GTKS and GHV series are pumping stations assembled with two horizontal centrifugal BG, CA, CEA, HM pump series or vertical multistage e-SV pump series.

The pumps are connected to one another by suction and delivery pipes, and fixed onto a single base. The pumps are connected to the manifolds by means of stop valves and check valves.

An electric protection and control panel is installed using a bracket on the base of the set.

The booster sets are fixed-speed (**GXS, GMD**) also variable-speed (**GTKS, GHV**).

CHOICE AND SELECTION

The following conditions should be considered when choosing a booster set:

- The system's requirements should be met regarding flow rate and pressure.
- The booster set must not be oversized, avoiding unnecessary installation and running costs.

Generally speaking, the water consumption in water distribution systems, such as DHW circuits for villas, detached houses and the like, is defined as "variable" though it is fairly concentrated during the day in what are known as peak consumption periods. Given the type of residential use, these concentrations of water demand mainly occur in the morning and in the evening.

The definition of the flow for these system types is generally based on practical tables giving the value of daily consumption depending on the type of user (number of occupants, number of services, etc..).

The size of the pressure booster set and, in practice, the performance levels of the pumps and the number of pumps is based on the take-off point and, therefore, on the consumption value which takes the following factors into account:

- The consumption peak
- Yield
- NPSH
- Diaphragm tanks

TWO-PUMP BOOSTER SETS SELECTING THE PUMPS

What type of pump to choose?

Generally, the choice of pump is based on the take-off point of the system, which is usually the highest possible. As maximum demand normally lasts a short time, the pump must also be able to satisfy variable requests throughout its time in service.

In this case, if variability is elevated, variable speed booster sets are preferred (**GTKS, GHV**).

Generally the choice of the pump, based on the performance curve, should fall around the maximum efficiency point. The pump must ensure operation within its rated performance.

Since the booster set is sized according to the maximum possible consumption, the take-off point of the pumps must be in the area on the right of the performance curve so that, if there is a fall in consumption, the efficiency remains high.

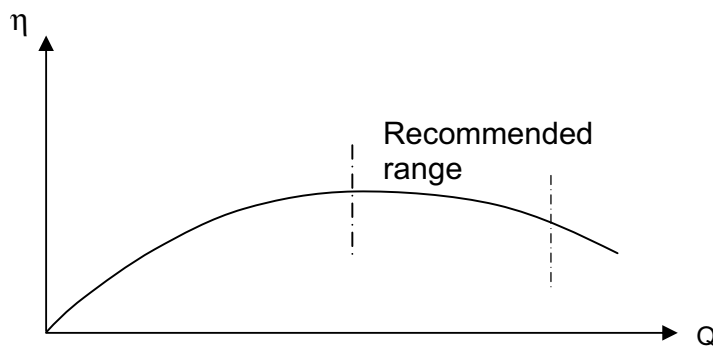

Pump performance curve

If we make a choice on the characteristic curve of the pump, we can see that the area where it is best to select the pump is represented by the following graph:

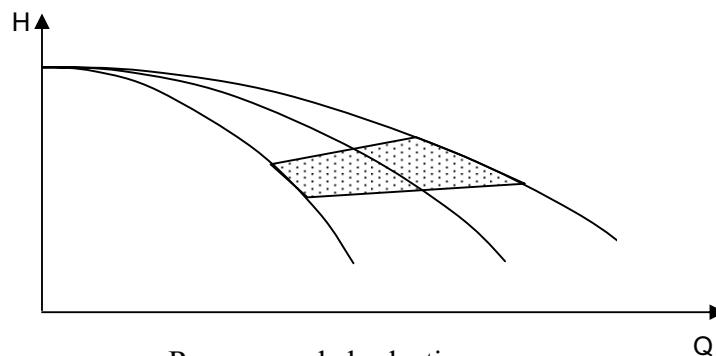

Recommended selection area

Another factor to be considered when choosing the pumps is its npsh value. Never choose a pump where the take-off point is too far to the right of the npsh curve.

This risks not having good pump suction, which may be aggravated by the type of installation (where negative suction is possible).

In these cases there is the risk of cavitation.

The npsh of the pump must always be checked at the maximum flow rate requested.

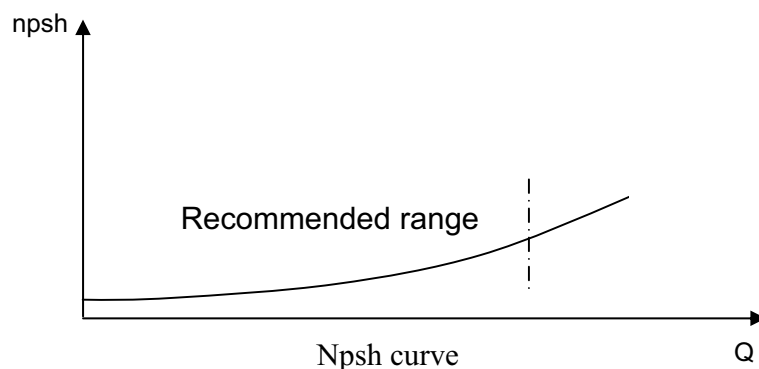

Npsh curve

TWO-PUMP BOOSTER SETS SELECTING THE PUMPS

The choice of pump is therefore based on the characteristic curve of the pump depending on the flow rate and the pressure required for the system. Starting from the required flow rate, a vertical line is drawn until it meets the horizontal line of the required pressure. The point of intersection of the lines gives both the type and the number of pumps necessary for the system.

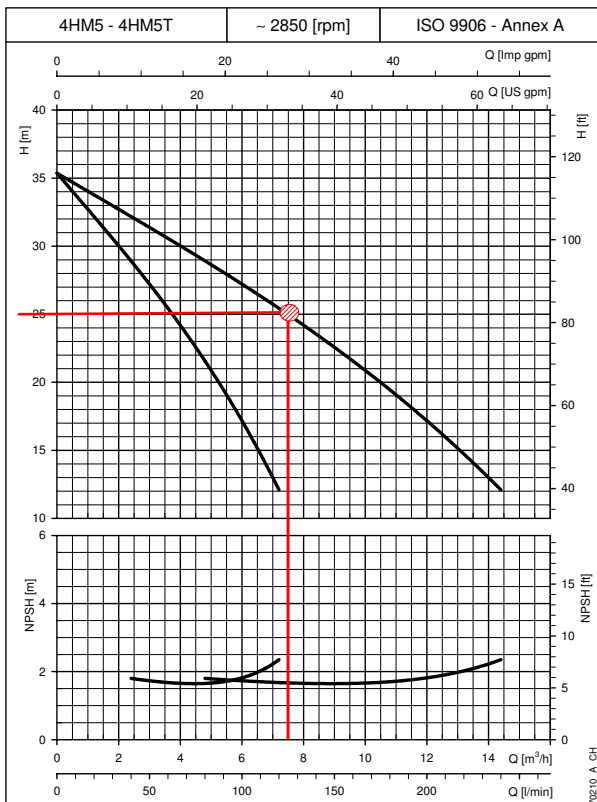

The example alongside refers to a required flow rate of 7,5 m³/h and a pressure of 25 water column.

As may be seen from the selection, the system requires two pumps of the type 4HM5 as indicated top left in the table.

Moreover the take-off point falls in the npsH area farthest to the left and therefore in an area with a low cavitation risk.

The values obtained are those for the performance of the pumps. A correct check of the net pressure value must be made due to the intrinsic load loss of the booster set and the conditions of installation.

TWO-PUMP BOOSTER SETS DESCRIPTION OF OPERATION

Cyclical exchange of pumps

Cyclical exchange of pumps is available for all series (**GXS, GMD, GTKS, GHV**). For the **GHV** series the pumps equipped each with its own drive alternate the start at every system restart or at a given time set for each pump by means of an internal clock in the drive menu.

In the **GXS** e **GMD** series, the cyclical exchange of pumps is controlled by electrical panel.

Protection against dry running

The protection function against dry running intervenes if the water reserve to which the booster set is connected falls below the minimum level guaranteed for suction.

The level may be controlled by a float, level probes or minimum pressure switch.

Tank

Frequent demand or **small system losses** determine pressure variations that may be compensated for by using a tank. Correct selection of a diaphragm tank **reduces the number of pump starts** and, if it is installed near the booster set, helps reduce the effect of water hammer.

The booster sets are **ready** for installation with diaphragm tanks mounted directly on the delivery manifold, and additional tanks can be connected to the unused end of the manifold.

A simplified calculation method, developed from experience, is provided in the Appendix. It supplies useful flow rate and head values for most common requirements, as well as a method for calculating diaphragm tank size.

Variable speed booster sets need **smaller tanks** compared to traditional systems. Generally speaking, a tank with a litre capacity of just 10% of the nominal capacity of a single pump, expressed in litres per minute, is needed.

TWO-PUMP BOOSTER SETS DESCRIPTION OF OPERATION

TWO-PUMP SETS WITH FIXED-SPEED MOTORS AND PRESSURE SWITCH CONTROL

The starting and stopping of the pumps are determined by the pressure values set on the pressure switches. Each pressure switch is connected to a single pump with a cyclic pump changeover. The differential pressure is the difference between starting pressure and switch-off pressure. It is set at the same value for both pumps.

Figure 2 shows the operating mode with the pumps' curves.

- On demand, water is drawn from the tank.
- When the pressure drops to the P1 value the first pump starts.
- If the water consumption increases and the pressure drops to the P2 value, the second pump starts.
- When consumption reduces and the pressure increases until it reaches the P2s value, one of the pumps is switched off.
- If consumption keeps reducing, the pump changes the tank and stops at the P1s value.

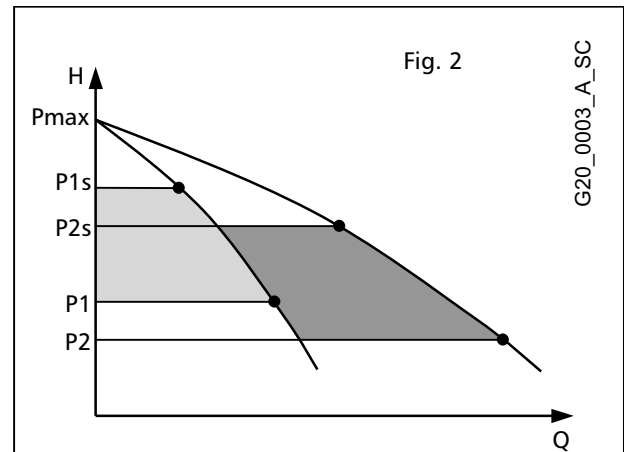

TWO-PUMP SETS WITH VARIABLE-SPEED MOTORS AND PRESSURE TRANSDUCER CONTROL

The starting and stopping of the pumps are determined by the pressure values set on the controller. Each frequency converter is connected to a pressure transducer. The converters exchange information with each other and provide for cyclic changeover.

Figure 3 shows the operating mode with the pumps' curves.

- On demand, water is drawn from the tank.
- When the pressure drops below the PS setting the first pump starts and the speed is adjusted to maintain a constant pressure as the demand increases.
- If the water consumption increases and the pump reaches maximum speed, the second pump starts and the speed is adjusted to maintain a constant pressure.
- When consumption reduces the speed is reduced until minimum speed is reached and one of the pumps is switched off.
- If consumption keeps reducing the pump slows down, charges the tank and stops at the PS setting.

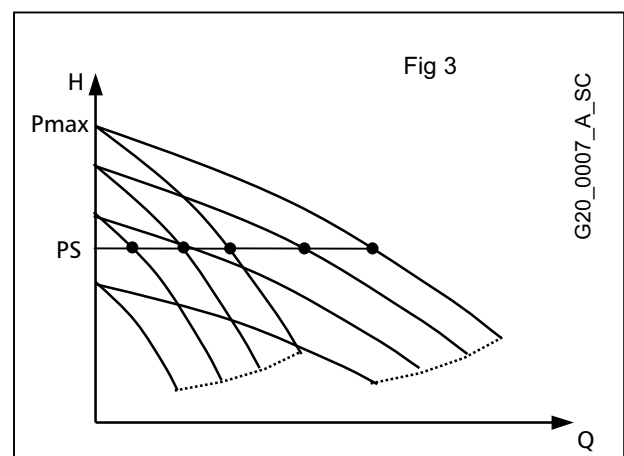

TWO-PUMP BOOSTER SETS RANGE

The range of two-pump booster sets includes fixed speed and variable speed systems available in a variety of material configurations to suit the specific requirements of different applications.



GXS SERIES SETS

- Single-phase power supply, fixed speed and pressure switch control. For BG, CA, CEA, HM and SV series electric pumps.

Flow rate up to 58 m³/h.
Power up to 2 x 1,5 kW.



GMD SERIES SETS

- Three-phase power supply, fixed speed and pressure switch control. For BG, CA, CEA, HM and SV series electric pumps.

Flow rate up to 62 m³/h.
Power up to 2 x 4 kW.



GTKS SERIES SETS

- Single-phase power supply, variable speed and control by pressure transducers and Teknospeed electronic speed controllers integrated with the motor. For BG, CA, CEA, HM and SV series electric pumps.

Flow rate up to 52 m³/h.
Power up to 2 x 1,1 kW.

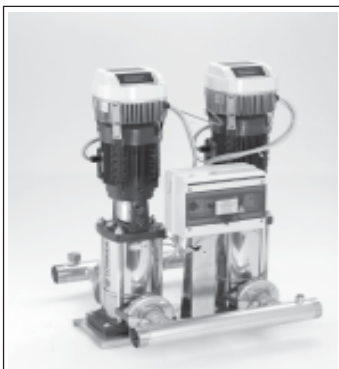

GHV SERIES SETS

- Single-phase or three-phase power supply, variable speed and control by pressure transducers and Hydrovar electronic speed controllers mounted on the motor. For SV series electric pumps.

Flow rate up to 58 m³/h.
Power up to 2 x 4 kW.

REFERENCE STANDARDS

- The Lowara two-pump booster sets are CE-marked for conformity with the following directives:
 - Machinery Directive: 2006/42/EC.
 - Low Voltage Directive 2006/95/EC.
 - Electromagnetic Compatibility Directive 2004/108/EC
- Electric pump performance complies with the following standard: ISO 9906-A Rotodynamic pumps – hydraulic performance acceptance tests.

TWO-PUMP BOOSTER SETS CHARACTERISTICS OF THE ELECTRIC PUMPS

The **BG, BGM** series comprises self-priming, single-impeller, horizontal centrifuge pumps featuring stainless steel bodies and rotors.

Motor: enbloc motor-pump coupling with rotor directly splined onto the motor shaft protrusion.



Technical Information:

Flow rates: up to 4,2 m³/h.

Head: up to 53 m.

Temperature of pumped liquid:
from -10°C to +40°C.

Maximum ambient temperature: +40°C.

Maximum suction head: 8 m.

Mechanical seal: Ceramic/Carbon/EPDM.

Elastomers: EPDM.

Motor

Standard supplied IE2/IE3 three-phase surface motors $\geq 0,75$ kW are compliant with Regulation (EC) no. 640/2009 and IEC 60034-30.

Electrical performances according to EN 60034-1.

Insulation class 155 (F).

IP55 protection.

Condensate drain plugs on standard version.

Cooling by fan according to EN 60034-6.

Cable gland metric size according to EN 50262.

Standard voltage:

- **Single-phase version:** 220-240 V 50 Hz (incorporated automatic-reset overload protection).
- **Three-phase version:** 220-240/380-415 V 50 Hz (overload protection to be provided by the user).

For electrical data of the motors used see Technical Appendix.

TWO-PUMP BOOSTER SETS CHARACTERISTICS OF THE ELECTRIC PUMPS

The **CEA, CEAM, CA, CAM** series comprises centrifuge pumps with single and twin impellers (**CA**) in pressed AISI 304 stainless steel. The enbloc centrifuge pump features axial suction and radial discharge. Compact construction, with pump coupled directly to motor; special motor shaft extension in common with the pump and supported by ball bearings. The rotating part can be removed from the control side without removing the pump body from the system piping. Threaded suction and discharge ports (Rp ISO 7).



Technical Information:

Flow rates: up to 31 m³/h.
Head: up to 62 m.

Temperature of pumped liquid:
from -10°C to +85°C (standard version).

Special versions on request.

Maximum operating pressure: 8 bar.

Power: from 0,37 to 3 kW.

Mechanical seal: Ceramic/Carbon/NBR.

Elastomers: NBR.

Motor

Standard supplied IE2/IE3 three-phase surface motors $\geq 0,75$ kW are compliant with Regulation (EC) no. 640/2009 and IEC 60034-30.

Electrical performances according to EN 60034-1.

Insulation class 155 (F).

IP55 protection.

Condensate drain plugs on standard version.

Cooling by fan according to EN 60034-6.

Cable gland metric size according to EN 50262.

Standard voltage:

- **Single-phase version:** 220-240 V 50 Hz (incorporated automatic-reset overload protection).
- **Three-phase version:** 220-240/380-415 V 50 Hz (overload protection to be provided by the user).

For electrical data of the motors used see Technical Appendix.

TWO-PUMP BOOSTER SETS CHARACTERISTICS OF THE ELECTRIC PUMPS

The **HM** series comprises horizontal multi-stage centrifuge pumps in pressed AISI 304 stainless steel. Compact construction, with pump coupled directly to motor; special motor shaft extension in common with the pump.



Technical Information:

Flow rates: up to 7,2 m³/h.
Head: up to 60,7 m.

Temperature of pumped liquid:
from -10°C to +60°C for HM-HMZ.
from -10°C to +110°C for HMS.

Maximum operating pressure: 8 bar.

Power: from 0,3 to 0,9 kW.

Mechanical seal: Ceramic/Carbon/EPDM.

Elastomers: EPDM.

Motor

Standard supplied IE2/IE3 three-phase surface motors $\geq 0,75$ kW are compliant with Regulation (EC) no. 640/2009 and IEC 60034-30.

Electrical performances according to EN 60034-1.

Insulation class 155 (F).

IP55 protection.

Condensate drain plugs on standard version.

Cooling by fan according to EN 60034-6.

Cable gland metric size according to EN 50262.

Standard voltage:

- **Single-phase version:** 220-240 V 50 Hz (incorporated automatic-reset overload protection).
- **Three-phase version:** 220-240/380-415 V 50 Hz (overload protection to be provided by the user).

For electrical data of the motors used see Technical Appendix.

TWO-PUMP BOOSTER SETS CHARACTERISTICS OF THE ELECTRIC PUMPS

The **e-SV** pump is a multistage vertical pump, not self-priming, combined with a normalised standard motor. The hydraulic part is kept in place between the upper cover and the pump body with tie-rods. The pump body is available in different configurations and connection typologies.



Technical Information:

Flow rates: up to 160 m³/h.

Heads: up to 160 m.

Temperature of pumped liquid:
from -30°C to +120°C (standard version).

Tested to ISO 9906 annex A.
Clockwise direction of rotation looking
at the pump from above (indicated
with an arrow on the bracket and joint).

Mechanical seal: Silicon carbide/Carbon/EPDM.
e-SV pumps (only for 10, 15, 22SV \geq 5,5 kW) are fitted
standard with a balanced mechanical seal that can be
replaced without having to remove the motor from the pump.

Elastomers: EPDM.

Motor

Standard supplied IE2/IE3 three-phase surface motors \geq 0,75 kW are compliant with Regulation (EC) no. 640/2009 and IEC 60034-30.

Electrical performances according to EN 60034-1.

Insulation class 155 (F).

IP55 protection.

Condensate drain plugs on standard version.

Cooling by fan according to EN 60034-6.

Cable gland metric size according to EN 50262.

Standard supplied e-SV electric pumps are equipped with Standard motors.

Standard voltage:

- **Single-phase version:** 220-240 V 50 Hz (incorporated automatic-reset overload protection).
- **Three-phase version:** 220-240/380-415 V 50 Hz (overload protection to be provided by the user).

For electrical data of the motors used see Technical Appendix.

Materials

The pumps for F, T, N versions are certified for drinking water use (**WRAS** and **ACS** certified).

TWO-PUMP BOOSTER SETS, HORIZONTAL DESIGN HYDRAULIC PERFORMANCE TABLE AT 50 HZ

PUMP TYPE	NOMINAL POWER	Q = DELIVERY													
		l/min 0	20	40	60	80	100	120	130	140					
		m ³ /h 0	1,2	2,4	3,6	4,8	6	7,2	7,8	8,4					
	kW	H = TOTAL HEAD METRES COLUMN OF WATER													
BG(M)3	2 x 0,37	36,9	30,6	25,6	21,5	17,7	13,8								
BG(M)5	2 x 0,55	40,2	35,7	32,0	28,8	25,7	22,4	18,8							
BG(M)7	2 x 0,75	45,4		38,1	34,8	31,7	28,6	25,6							
BG(M)9	2 x 0,9	49,6		41,1	37,7	34,8	32,2	29,8	28,6						
BG(M)11	2 x 1,1	53,2		45,8	42,5	39,5	36,5	33,5	31,9	30,3					

PUMP TYPE	NOMINAL POWER	Q = DELIVERY										
		l/min 0	40	60	80	100	120	140	160	200	240	
		m ³ /h 0	2,4	3,6	4,8	6	7,2	8,4	9,6	12	14,4	
	kW	H = TOTAL HEAD METRES COLUMN OF WATER										
2HM3(T)	2 x 0,3	23,8	21,4	19,7	17,6	15,2	12,5	9,4				
2HM4(T)	2 x 0,45	35,4	32,0	29,5	26,5	23,0	19,0	14,5				
2HM5(T)	2 x 0,55	46,8	42,1	38,8	34,9	30,4	25,3	19,6				
2HM7(T)	2 x 0,75	58,5	53,2	49,5	44,9	39,5	33,2	25,8				
4HM4(T)	2 x 0,45	24,6			20,3	19,1	17,8	16,5	15,0	11,9	8,3	
4HM5(T)	2 x 0,55	35,4			28,9	27,2	25,4	23,6	21,6	17,2	12,1	
4HM7(T)	2 x 0,75	48,1			40,2	38,2	36,0	33,7	31,2	25,2	17,7	
4HM9(T)	2 x 0,9	60,7			51,2	48,6	45,9	42,9	39,7	32,4	23,6	

PUMP TYPE	NOMINAL POWER	Q = DELIVERY																	
		l/min 0	60	80	120	160	200	240	280	320	360	400	500	600	700	800	860	960	1040
		m ³ /h 0	3,6	4,8	7,2	9,6	12	14,4	16,8	19,2	21,6	24	30	36	42	48	51,6	57,6	62,4
	kW	H = TOTAL HEAD METRES COLUMN OF WATER																	
CEA(M)70/3	2 x 0,37	22	20,1	19,1	16,6	12,8													
CEA(M)70/5	2 x 0,55	31,1	28,8	27,7	24,7	20,2													
CEA(M)80/5	2 x 0,75	32	30	29,3	27,4	24,7	21												
CEA(M)120/3	2 x 0,55	22,4			18,9	17,5	15,9	14	11,8	9,2									
CEA(M)120/5	2 x 0,9	31,8			28,2	26,5	24,6	22,4	20	17,3									
CEA(M)210/2	2 x 0,75	17,7						16,5	16,1	15,6	15	14,4	12,6	10,4					
CEA(M)210/3	2 x 1,1	20,8						19,7	19,3	19	18,5	18	16,5	14,4					
CEA(M)210/4	2 x 1,5	25,5						24,8	24,5	24	23,6	23	21,3	19,0					
CEA(M)210/5	2 x 1,85	29,0						28,2	27,9	28	27,1	27	25,1	23,1					
CEA(M)370/1	2 x 1,1	16,3									15,5	15	14,3	13,0	11,4	9,4	8,1		
CEA(M)370/2	2 x 1,5	20,4										19	18,3	17,2	15,8	14,1	13,0	10,8	
CEA(M)370/3	2 x 1,85	24,4										23	22,1	21,1	19,8	18,2	17,1	15,0	13
CEA370/5	2 x 3	30										28,3	27,5	26,5	25,3	23,8	22,8	20,8	19,0

PUMP TYPE	NOMINAL POWER	Q = DELIVERY											
		l/min 0	60	80	100	120	140	160	200	240	300	360	420
		m ³ /h 0	3,6	4,8	6	7,2	8,4	9,6	12	14,4	18	21,6	25,2
	kW	H = TOTAL HEAD METRES COLUMN OF WATER											
CA(M)70/33	2 x 0,75	42,9	38,8	36,9	34,6	31,7	28,2	23,9					
CA(M)70/34	2 x 0,9	48,8	45,1	43,2	40,7	37,7	34,0	29,5					
CA(M)70/45	2 x 1,1	56,2	52,0	49,8	47,1	43,9	39,9	35,3					
CA(M)120/33	2 x 1,1	44,3			39,1	37,8	36,4	34,8	31,4	27,6	21,0		
CA(M)120/35	2 x 1,5	54,0			49,4	48,1	46,6	44,9	41,2	36,8	29,3		
CA(M)120/55	2 x 2,2	63,8			59,6	58,2	56,6	54,8	50,6	45,7	37,1		
CA(M)200/33	2 x 1,85	43,2			41,8	41,2	40,6	39,9	38,3	36,4	33,2	29,5	25,5
CA200/35	2 x 2,2	53,5			52,4	51,9	51,4	50,7	49,2	47,5	44,3	40,6	36,5
CA200/55	2 x 3	62,6			61,0	60,6	60,1	59,5	58,2	56,6	53,8	50,4	46,2

The table refers to performance with 2 pumps running.

g20o-2p50-en_c_th

TWO-PUMP BOOSTER SETS, VERTICAL DESIGN HYDRAULIC PERFORMANCE TABLE AT 50 HZ

PUMP TYPE	NOMINAL POWER kW	Q = DELIVERY															
		l/min 0	24	40	50	60	70	80	90	100	146	166,6	200	266	282	340	366
		m ³ /h 0	1,4	2,4	3,0	3,6	4,2	4,8	5,4	6,0	8,8	10,0	12,0	16,0	16,9	20,4	22,0
H = TOTAL HEAD METRES COLUMN OF WATER																	
3SV02F(T)	2 x 0,37	14,9		14,5	14,3	14,0	13,5	13,0	12,4	11,7	9,8	6,5					
3SV03F(T)	2 x 0,37	22,0		21,2	20,8	20,3	19,6	18,7	17,7	16,6	13,7	8,6					
3SV04F(T)	2 x 0,37	28,9		27,7	27,1	26,2	25,2	23,9	22,5	20,8	16,8	10,1					
3SV05F(T)	2 x 0,55	37,2		36,4	35,8	35,0	33,9	32,6	31,1	29,2	24,5	16,2					
3SV06F(T)	2 x 0,55	44,4		43,4	42,6	41,6	40,2	38,6	36,6	34,3	28,5	18,5					
3SV07F(T)	2 x 0,75	52,5		51,8	51,0	50,0	48,7	47,0	45,0	42,5	36,1	24,6					
3SV08F(T)	2 x 0,75	60,0		59,1	58,2	57,0	55,4	53,4	51,0	48,1	40,7	27,5					
3SV09F(T)	2 x 1,1	67,7		66,8	65,8	64,5	62,8	60,6	57,9	54,6	46,4	31,6					
3SV10F(T)	2 x 1,1	75,0		73,8	72,7	71,3	69,3	66,9	63,8	60,2	51,0	34,5					
3SV11F(T)	2 x 1,1	82,3		81,0	79,7	78,0	75,8	73,1	69,7	65,7	55,5	37,4					
3SV12F(T)	2 x 1,1	89,6		87,8	86,4	84,5	82,1	79,1	75,5	71,1	59,9	40,1					
3SV13F(T)	2 x 1,5	98,1		96,7	95,4	93,5	91,0	87,8	83,9	79,2	67,2	45,6					
3SV14F(T)	2 x 1,5	105,6		104,1	102,5	100,4	97,7	94,2	89,9	84,8	71,8	48,5					
3SV16F(T)	2 x 1,5	119,9		117,8	116,1	113,6	110,5	106,5	101,6	95,8	80,9	54,2					
3SV19F(T)	2 x 2,2	144,3		142,3	140,3	137,5	133,9	129,2	123,5	116,7	99,1	67,6					
3SV21F(T)	2 x 2,2	159,3		156,9	154,6	151,4	147,3	142,1	135,7	128,0	108,5	73,6					
5SV02F(T)	2 x 0,37	14,8						13,8	13,7	13,4	12,2	11,5	10,2	6,7	5,7		
5SV03F(T)	2 x 0,55	21,8						19,9	19,6	19,2	17,1	16,0	13,9	8,5	6,9		
5SV04F(T)	2 x 0,55	30,0						28,2	27,9	27,5	25,2	23,8	21,2	14,3	12,2		
5SV05F(T)	2 x 0,75	38,0						36,4	36,0	35,5	32,9	31,3	28,2	19,7	17,1		
5SV06F(T)	2 x 1,1	45,3						43,7	43,3	42,8	39,6	37,7	33,9	23,5	20,3		
5SV07F(T)	2 x 1,1	52,7						50,7	50,1	49,5	45,8	43,5	39,1	26,8	23,1		
5SV08F(T)	2 x 1,1	60,1						57,6	57,0	56,2	51,8	49,2	44,1	30,0	25,8		
5SV09F(T)	2 x 1,5	68,0						65,5	64,8	64,0	59,3	56,4	50,6	35,0	30,2		
5SV10F(T)	2 x 1,5	75,5						72,4	71,7	70,8	65,4	62,1	55,7	38,3	33,0		
5SV11F(T)	2 x 1,5	82,8						79,3	78,4	77,5	71,4	67,8	60,7	41,4	35,6		
5SV12F(T)	2 x 2,2	90,8						88,0	87,0	86,0	79,3	75,2	67,4	46,7	40,5		
5SV13F(T)	2 x 2,2	98,3						95,0	94,0	92,8	85,5	81,1	72,6	50,1	43,5		
5SV14F(T)	2 x 2,2	105,7						102,0	100,9	99,6	91,7	87,0	77,8	53,5	46,3		
5SV15F(T)	2 x 2,2	113,1						109,0	107,8	106,4	97,8	92,7	82,8	56,8	49,1		
5SV16F(T)	2 x 2,2	120,5						115,9	114,6	113,1	103,9	98,4	87,8	60,0	51,8		
5SV18F(T)	2 x 3	135,8						131,1	129,7	128,0	117,8	111,7	99,9	68,7	59,5		
5SV21F(T)	2 x 3	157,9						152,0	150,3	148,3	136,1	128,9	114,9	78,4	67,6		

The table refers to performance with 2 pumps running.

g20v-2p50-en_c_th

TWO-PUMP BOOSTER SETS, VERTICAL DESIGN HYDRAULIC PERFORMANCE TABLE AT 50 HZ

PUMP TYPE	NOMINAL POWER kW	Q = DELIVERY													
		l/min 0	166,68	200	266	340	366,68	466	540	660	700	800	860	920	966,66
		m ³ /h 0	10,0	12,0	16,0	20,4	22,0	28,0	32,4	39,6	42,0	48,0	51,6	55,2	58,0
H = TOTAL HEAD METRES COLUMN OF WATER															
10SV01F(T)	2 x 0.75	11,8	11,2	10,9	9,9	9,6	8,3	7,6	4,3						
10SV02F(T)	2 x 0.75	23,6	21,9	21,3	19,6	19,1	17,0	15,8	10,0						
10SV03F(T)	2 x 1.1	35,7	33,0	32,1	29,6	28,9	25,8	24,1	16,0						
10SV04F(T)	2 x 1.5	47,7	44,2	43,0	39,9	38,9	34,8	32,6	21,7						
10SV05F(T)	2 x 2.2	60,0	56,1	54,7	50,9	49,8	44,9	42,2	29,0						
10SV06F(T)	2 x 2.2	71,8	66,8	65,0	60,4	59,0	53,1	49,8	33,9						
10SV07F(T)	2 x 3	83,6	78,3	76,2	70,8	69,2	62,1	58,3	39,8						
10SV08F(T)	2 x 3	95,3	88,9	86,5	80,1	78,3	70,2	65,7	44,5						
10SV09F(T)	2 x 4	106,3	100,1	97,5	90,8	88,7	80,0	75,1	52,1						
10SV10F(T)	2 x 4	118,0	110,8	107,9	100,3	98,0	88,2	82,8	57,2						
10SV11F(T)	2 x 4	129,6	121,3	118,1	109,6	107,1	96,3	90,3	62,1						
15SV01F	2 x 1,1	14,0			12,9	12,4	12,2	11,3	10,4	8,4	7,6	5,1			
15SV02F	2 x 2,2	28,7			26,7	25,9	25,5	23,9	22,4	18,9	17,4	13,1			
15SV03F	2 x 3	43,3			40,4	39,1	38,6	36,2	33,8	28,7	26,5	20,1			
15SV04F	2 x 4	58,4			54,7	53,1	52,5	49,4	46,3	39,7	36,9	28,7			
15SV05F	2 x 4	72,7			67,8	65,8	65,0	61,0	57,1	48,7	45,2	34,9			
22SV01F	2 x 1,1	14,7					13,5	12,7	12,0	10,4	9,7	7,7	6,3	4,7	3,4
22SV02F	2 x 2,2	30,4					28,4	27,2	26,0	23,3	22,2	18,9	16,6	13,8	11,5
22SV03F	2 x 3	45,4					42,2	40,4	38,5	34,5	32,8	27,8	24,2	20,2	16,6
22SV04F	2 x 4	60,9					56,8	54,4	51,9	46,6	44,4	37,9	33,1	27,7	23,0

The table refers to performance with 2 pumps running.

g20_10-22sv-2p50_en_a_th

TWO-PUMP BOOSTER SETS ELECTRICAL DATA TABLE

PUMP		GXS20	GMD20	GTKS20	GHV20../M	GHV20../T
TYPE	NOMINAL POWER kW	CURRENT ABSORBED	CURRENT ABSORBED	CURRENT ABSORBED	CURRENT ABSORBED	CURRENT ABSORBED
		1 x 230 V A	3 x 400 V A	1 x 230 V A	1 x 230 V A	3 x 400 V A
BG3	2 x 0,37	5,9	3,0	4,6	-	-
BG5	2 x 0,55	8,7	3,2	6,8	-	-
BG7	2 x 0,75	10,0	3,7	9,3	-	-
BG9	2 x 0,9	11,1	4,4	11,1	-	-
BG11	2 x 1,1	12,9	4,8	13,6	-	-
2HM3(ZT)	2 x 0,3	4,7	2,1	3,7	-	-
2HM4(ZT)	2 x 0,45	5,8	3,0	5,6	-	-
2HM5(ZT)	2 x 0,55	7,4	3,4	6,8	-	-
2HM7(ZT)	2 x 0,75	10,2	3,7	9,3	-	-
4HM4(ZT)	2 x 0,45	5,5	2,9	5,6	-	-
4HM5(ZT)	2 x 0,55	7,5	3,4	6,8	-	-
4HM7(ZT)	2 x 0,75	11,5	4,5	9,3	-	-
4HM9(ZT)	2 x 0,9	13,0	4,9	11,1	-	-
CEA 70/3	2 x 0,37	5,4	2,9	4,6	-	-
CEA 70/5	2 x 0,55	9,1	3,3	6,8	-	-
CEA 80/5	2 x 0,75	9,7	3,6	9,3	-	-
CEA 120/3	2 x 0,55	8,7	3,2	6,8	-	-
CEA 120/5	2 x 0,9	12,5	4,7	11,1	-	-
CEA 210/2	2 x 0,75	10,2	3,7	9,3	-	-
CEA 210/3	2 x 1,1	13,4	4,9	13,6	-	-
CEA 210/4	2 x 1,5	17,2	6,3	-	-	-
CEA 210/5	2 x 1,85	-	8,5	-	-	-
CEA 370/1	2 x 1,1	13,5	5,0	13,6	-	-
CEA 370/2	2 x 1,5	18,5	6,9	-	-	-
CEA 370/3	2 x 1,85	-	9,1	-	-	-
CEA370/5	2 x 3	-	11,7	-	-	-
CA 70/33	2 x 0,75	10,3	3,7	9,3	-	-
CA 70/34	2 x 0,9	12,4	4,7	11,1	-	-
CA 70/45(44)	2 x 1,1	15,8	5,7	13,6	-	-
CA 120/33	2 x 1,1	15,1	5,4	13,6	-	-
CA 120/35	2 x 1,5	19,7	7,1	-	-	-
CA 120/55	2 x 2,2	-	9,3	-	-	-
CA 200/33	2 x 1,85	-	8,6	-	-	-
CA 200/35	2 x 2,2	-	10,5	-	-	-
CA 200/55	2 x 3	-	12,4	-	-	-

The current shown is the nominal current of the set.

a20o-2p50-en a te

TWO-PUMP BOOSTER SETS ELECTRICAL DATA TABLE

PUMP		GXS20	GMD20	GTKS20	GHV20../M	GHV20../T
TYPE	NOMINAL POWER kW	CURRENT ABSORBED	CURRENT ABSORBED	CURRENT ABSORBED	CURRENT ABSORBED	CURRENT ABSORBED
		1 x 230 V A	3 x 400 V A	1 x 230 V A	1 x 230 V A	3 x 400 V A
3SV02F(T)	2 x 0,37	5,6	2,7	4,6	-	-
3SV03F(T)	2 x 0,37	5,6	2,7	4,6	-	-
3SV04F(T)	2 x 0,37	5,6	2,7	4,6	-	-
3SV05F(T)	2 x 0,55	7,7	3,0	6,8	-	-
3SV06F(T)	2 x 0,55	7,7	3,0	6,8	-	-
3SV07F(T)	2 x 0,75	9,7	3,4	9,3	10,6	-
3SV08F(T)	2 x 0,75	9,7	3,4	9,3	10,6	-
3SV09F(T)	2 x 1,1	13,4	4,8	13,6	14,9	5,0
3SV10F(T)	2 x 1,1	13,4	4,8	13,6	14,9	5,0
3SV11F(T)	2 x 1,1	13,4	4,8	13,6	14,9	5,0
3SV12F(T)	2 x 1,1	13,4	4,8	13,6	14,9	5,0
3SV13F(T)	2 x 1,5	17,5	6,3	-	19,8	6,7
3SV14F(T)	2 x 1,5	17,5	6,3	-	19,8	6,7
3SV16F(T)	2 x 1,5	17,5	6,3	-	19,8	6,7
3SV19F(T)	2 x 2,2	-	9,3	-	29,0	9,7
3SV21F(T)	2 x 2,2	-	9,3	-	29,0	9,7
5SV02F(T)	2 x 0,37	5,6	2,7	4,6	-	-
5SV03F(T)	2 x 0,55	7,7	3,0	6,8	-	-
5SV04F(T)	2 x 0,55	7,7	3,0	6,8	-	-
5SV05F(T)	2 x 0,75	9,7	3,4	9,3	10,6	-
5SV06F(T)	2 x 1,1	13,4	4,8	13,6	14,9	5,0
5SV07F(T)	2 x 1,1	13,4	4,8	13,6	14,9	5,0
5SV08F(T)	2 x 1,1	13,4	4,8	13,6	14,9	5,0
5SV09F(T)	2 x 1,5	17,5	6,3	-	19,8	6,7
5SV10F(T)	2 x 1,5	17,5	6,3	-	19,8	6,7
5SV11F(T)	2 x 1,5	17,5	6,3	-	19,8	6,7
5SV12F(T)	2 x 2,2	-	9,3	-	29,0	9,7
5SV13F(T)	2 x 2,2	-	9,3	-	29,0	9,7
5SV14F(T)	2 x 2,2	-	9,3	-	29,0	9,7
5SV15F(T)	2 x 2,2	-	9,3	-	29,0	9,7
5SV16F(T)	2 x 2,2	-	9,3	-	29,0	9,7
5SV18F(T)	2 x 3	-	12,3	-	-	12,9
5SV21F(T)	2 x 3	-	12,3	-	-	12,9
10SV01F(T)	2 x 0,75	9,7	3,4	9,3	10,6	-
10SV02F(T)	2 x 0,75	9,7	3,4	9,3	10,6	-
10SV03F(T)	2 x 1,1	13,4	4,8	13,6	14,9	5,0
10SV04F(T)	2 x 1,5	17,5	6,3	-	19,8	6,7
10SV05F(T)	2 x 2,2	-	9,3	-	29,0	9,7
10SV06F(T)	2 x 2,2	-	9,3	-	29,0	9,7
10SV07F(T)	2 x 3	-	12,3	-	-	12,9
10SV08F(T)	2 x 3	-	12,3	-	-	12,9
10SV09F(T)	2 x 4	-	15,4	-	-	16,2
10SV10F(T)	2 x 4	-	15,4	-	-	16,2
10SV11F(T)	2 x 4	-	15,4	-	-	16,2
15SV01F	2 x 1,1	13,4	4,8	13,6	14,9	5,0
15SV02F	2 x 2,2	-	9,3	-	29,0	9,7
15SV03F	2 x 3	-	12,3	-	-	12,9
15SV04F	2 x 4	-	15,4	-	-	16,2
15SV05F	2 x 4	-	15,4	-	-	16,2
22SV01F	2 x 1,1	13,4	4,8	13,6	14,9	5,0
22SV02F	2 x 2,2	-	9,3	-	29,0	9,7
22SV03F	2 x 3	-	12,3	-	-	12,9
22SV04F	2 x 4	-	15,4	-	-	16,2

The current shown is the nominal current of the set.

a20v 2p50-en a te

Booster sets

MARKET SECTORS

CIVIL, INDUSTRIAL

APPLICATIONS

- Water network supply in condominiums, offices, hotels, shopping centres, factories.
- Water supply to agricultural water networks (e.g. irrigation).

GXS20 Series



GXS20

SPECIFICATIONS

- **Flow rate** up to 58 m³/h.
- **Head** up to 120 m.
- Electrical panel supply voltage:
1 x 230V ± 10%.
- Frequency: 50 Hz.
- Protection class
electrical panel IP 55.
- Maximum electric pump
power 2 x 1,5 kW.
- Direct motor start.
- Maximum temperature of pumped liquid:
from -10 to +80° C (for BGM, CEAM, CAM, SV..M).
from -10 to +60° C (for HM, HMZ).
- **Horizontal design pump:**
BGM-CEAM-CAM-HM-HMZ series.
Maximum operating pressure 8 bar.
- **Vertical design pump:**
SV..M series.
Maximum operating pressure 16 bar.

TWO-PUMP BOOSTER SETS, GXS20 SERIES IDENTIFICATION CODE

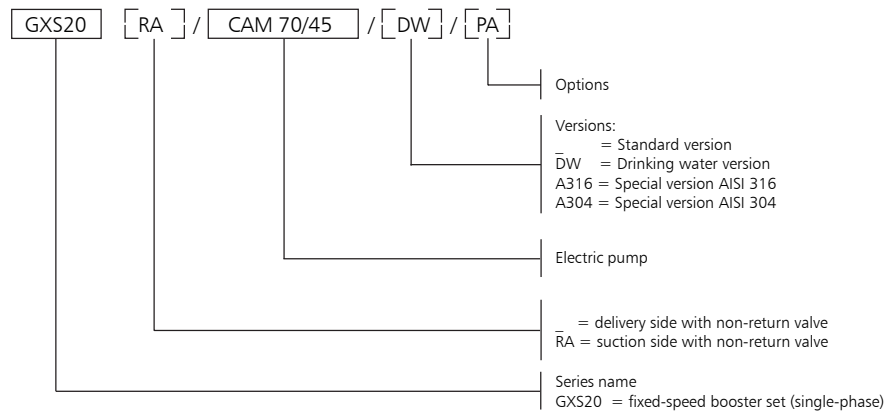

OPTIONS (ON DEMAND)

- 3A Booster set with electric pump certified 1A (Factory test reports issued by the end of assembly line; it includes QH curve).
- 3B Booster set with electric pump certified 1B (Test report issued by Audit Test Lab; it includes QH curve, efficiency and power).
- 60 Booster set with 60Hz supply voltage.
- BAP High pressure switch installed on the delivery manifold.
- C9 Delivery manifold at 90° with bend. The tanks can not be installed directly on the manifold.
- CM Suction or delivery manifold larger than standard size.
- CP Dry contact version: power line, Automatic/Manual mode, Run/Stop for each pump, thermal block.
- MA Pressure gauge installed on suction manifold.
- NL Dutch market version.
- PA Minimum pressure gauge installed on the suction manifold for dry-running protection.
- PQ Booster set with high suction pressure (pressure gauge/pressure switches increased of one range).
- RA Non return valves mounted on suction side (I.e:GXS20RA/SV...).
- SA No intake: no suction valves and suction manifold.
- SC Group with no control devices, such as pressure switches and transmitters; the pressure gauge is present.
- SCA No suction manifold (suction valves present).
- SCM Without delivery manifold (no pressure transmitters and pressure gauge, with delivery valves).
- SM Without delivery: without valves on delivery and without delivery manifold.
- TS Booster set with pumps equipped with special mechanical seals.
- UK UK market version.
- WM Wall-mounted electrical panel with fixing tabs. Cables L= 5m

AVAILABLE VERSIONS

- A304 Main component in contact with liquid in stainless steel Aisi 304 or superior; gasket, sealing tape and thread sealing are suitable for drinking water. Bolts and screws galvanized. Flanges not in contact with the liquid in galvanized steel.
- B304 Main component in contact with liquid in stainless steel Aisi 304 or superior; gasket, sealing tape and thread sealing are suitable for drinking water. Bolts and screws in Aisi 304 or superior. Flanges not in contact with the liquid in Aisi 304 or superior.
- C304 Main component in contact with liquid in stainless steel Aisi 304 or superior; gasket, sealing tape and thread sealing are suitable for drinking water. Baseplate, frame, supports, bolts and screws in Aisi 304 or superior. Flanges not in contact with the liquid in Aisi 304 or superior. Valves and their components completely in Aisi 304 or superior (body, disc, plate).
- A316 Main component in contact with liquid in stainless steel Aisi 316; gasket, sealing tape and thread sealing are suitable for drinking water. Pumps in Aisi 316 material. Bolts and screws galvanized. Flanges not in contact with the liquid in galvanized steel.
- B316 Main component in contact with liquid in stainless steel Aisi 316; gasket, sealing tape and thread sealing are suitable for drinkingwater. Pumps in Aisi 316 material. Bolts and screws in Aisi 316. Flanges not in contact with the liquid in Aisi 316.
- C316 Main component in contact with liquid in stainless steel Aisi 316; gasket, sealing tape and thread sealing are suitable for drinking water. Pumps in Aisi 316 material. Baseplate, frame, supports, bolts and screws in Aisi 316. Flanges not in contact with the liquid in Aisi 316. Valves and their components completely in Aisi 316 (body, disc, plate).
- DW Main component in contact with fluid suitable for drinking water or in stainless steel AISI 304 or superior quality.

TWO-PUMP BOOSTER SETS, GXS20 SERIES OPERATING CHARACTERISTICS AND LIMITS

Liquids handled	Water containing no gas or corrosive and/or aggressive substances.
Fluid temperature	Depending on the type of pump: SV..M, CEAM, CAM: da oltre -10°C a + 80 °C. HM, HMZ: da oltre -10°C a + 60 °C.
Ambient temperature	Above 0°C a + 40 °C.
Maximum operating pressure	Max 8 bar, 10 bar, 16 bar Depending on the type of pump.
Minimum inlet pressure	According to NPSH curve and losses, with a minimum margin of 0.5 m.
Maximum inlet pressure	The inlet pressure added to the pressure of the pump at zero flow must be lower than the maximum operating pressure of the set
Hourly starts (single pump)	Max 60 up to 3 kW, above 3 kW and up to 4 kW max 40.
Installation	Indoors, protected from the weather. Away from heat sources. Max elevation 1000 m ASL. Max humidity 50% without condensation.
Sound emission	Sound emission level Lp < 70 dB(A) for two-pump set with 2900 rpm motor with power up to 2 x 4 kW.

gxs20-en_2p_a_ti

TABLE OF MATERIALS

NAME	MATERIAL			
	(STANDARD)	DW	A304	A316
Manifolds	AISI 304	AISI 304	AISI 304	AISI 316
On-off valves	Nickel-plated brass	Nickel-plated brass	AISI 316	AISI 316
Non-return valves	Brass	Brass	AISI 304	AISI 316
Pressure switches	Chrome plated zinc alloy	AISI 304	AISI 304	AISI 304
Pressure trasmitter	AISI 316	AISI 316	AISI 316	AISI 316
Caps/plugs/flanges	Galvanized steel	AISI 304	AISI 304	AISI 316
Bracket	Galvanized steel	Galvanized steel	Galvanized steel	Galvanized steel
Base	Galvanized steel	Galvanized steel	Galvanized steel	Galvanized steel
Pump Body	AISI 304	AISI 304	AISI 304	AISI 316(*)

* Not all models of electric pumps are available in AISI 316. Consult technical catalog of pump.

gxs20_2p-en_a_tm

TWO-PUMP BOOSTER SETS, GXS20 SERIES MAIN COMPONENTS

GXS20

- **Main On-off valves** on suction and discharge side of each pump, ball type with threaded coupling.
- **Check valve** on discharge side of each pump, spring-loaded type, with threaded coupling. For applications with air-cushion surge tanks, they are mounted on the suction side and the set is equipped with a connector for G 1/2" threaded flexible air feeder pipe (GXS20..RA series).
- **Suction manifold** made of galvanized or AISI 304 stainless steel with threaded ends. Threaded coupling for water charging.
- **Delivery manifold** made of galvanized or AISI 304 stainless steel with threaded ends. Fitted with R1" threaded couplings with caps to allow connection of 24 or 20-litre diaphragm pressure vessels.
- **Pressure gauge and 2 control transmitters** located on the delivery side of the unit.
- **Various couplings** in nickel-plated brass, galvanized steel or stainless steel depending on the version.
- **Mounting base**, for pumpset and panel mounting brackets in galvanized steel.
- **Electric control panel**, IP55 protection class.

STANDARD VERSIONS AVAILABLE

See table of materials.

STANDARD VERSION

For general applications

Valves in brass or nickel plated brass, galvanized steel or brass fittings.

DW VERSION (GXS20../DW)

For drinking water applications.

The main components in contact with the liquid are certified suitable for drinking water or are made of AISI 304 or higher grade of stainless steel.

AISI304 Version (GXS20../A304), AISI 316 (GXS20../A316)

For special applications

Manifolds, valves, non-return valves and main components with parts directly in contact with the pumped liquid are made of AISI 304 or AISI 316 stainless steel.

Accessories available on request:

- Devices **against dry running** in one of the following versions:
 - float switch, for positive suction head;
 - probe electrodes kit, for positive suction head;
 - minimum pressure switch, for positive suction head.
- **Surge tank** in the following versions:
 - Air-cushion surge tank with compressor and accessories for surge tank and compressor.
 - Diaphragm vessel as an alternative to the air-cushion tank.
- **Kit featuring** a 24 or 20-litre **diaphragm expansion vessel** with ball valve (one for each pump), in the following versions, depending on the maximum head of the pumps:
 - 24-litre 8 bar cylinder water vessel kit
 - 24-litre 10 bar cylinder water vessel kit
 - 24-litre 16 bar cylinder water vessel kit
 - 20-litre 25 bar cylinder water vessel kit
- **Alarm kit**;
- **Air feeder** for **RA** version;
- **Air compressor** for **RA** version.

SPECIAL VERSIONS AVAILABLE ON REQUEST

(Contact the Sales and technical Assistance Service)

- Support base in AISI 304, AISI 316 stainless steel.
- Units with stainless steel expansion vessels.
- Units with special valves.
- Sets with jockey pump.

TWO-PUMP BOOSTER SETS, GXS20 SERIES CONTROL PANEL

Electrical panel (fig. 1), single-phase power input, for controlling and protecting up to two single-phase electric pumps, made from polycarbonate and protected to IP55.

Main characteristics:

- Automatic switch with general overload protection.
- Standard supply voltage: 1x230Vac +/-10%, 50/60Hz.
- Lowara SX20 digital control unit (fig 2), with microprocessors, offers the following functions:
 - Indicator LED's: power on (ref. 1), general fault and no water level alarm (ref. 2), pump running (ref. 3).
 - Automatic, manual or disabled mode switches for each pump (ref. 4).
 - Automatic cascade control of electric pumps via two pressure switches.
 - Cycle reversal function (can be disabled). Automatically switches pumps after every start/stop cycle.
 - No-water protection system alternatives: float, minimum pressure switch, external contact or electrode probes with sensitivity adjustment.
 - Adjustable timer delaying tripping the no-water protection system (inside board).
 - Adjustable timer extending the operation of each pump (inside board).
 - A relay board (optional) can be connected to boost the following signals: pump 1,2 running, aut-man mode, overload alarm, no-water alarm, power on.
- External enable connection or pressure switch for maximum pressure protection.

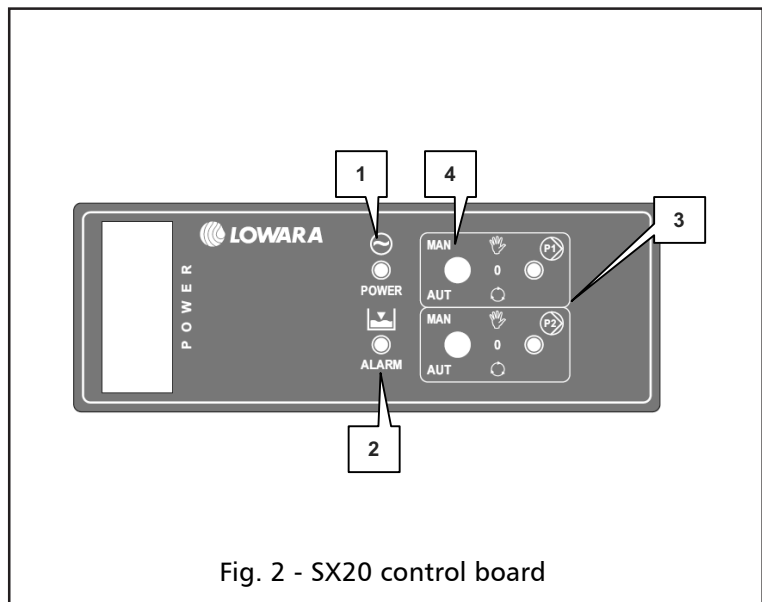

TWO-PUMP BOOSTER SETS, GXS20 SERIES HORIZONTAL ELECTRIC PUMPS WITH NON-RETURN VALVE ON DELIVERY SIDE

GXS20

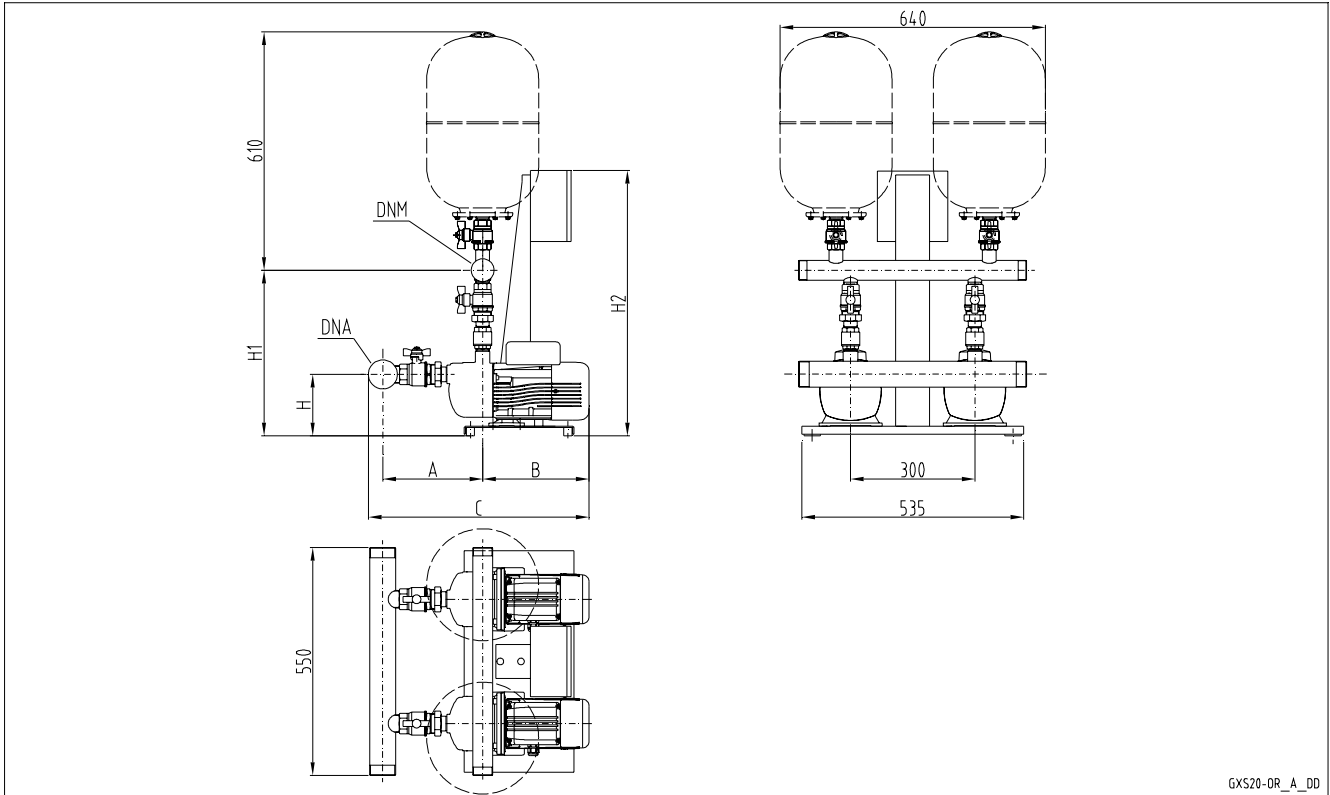

GXS20-OR_A_DD

GXS 20	DNA	DNM	A		B	C		H	H1		H2
			STD / DW	AISI		STD / DW	AISI		STD / DW	AISI	
BGM3	R 2"	R 1 1/2"	214	299	297	541	626	189	423	501	640
BGM5	R 2"	R 1 1/2"	214	299	311	555	640	189	423	501	640
BGM7	R 2"	R 1 1/2"	214	299	356	600	685	189	423	501	640
BGM9	R 2"	R 1 1/2"	214	299	356	600	685	189	423	501	640
BGM11	R 2"	R 1 1/2"	214	299	356	600	685	189	423	501	640
2HM3	R 2"	R 1 1/2"	241	326	249	520	605	149	382	460	640
2HM4	R 2"	R 1 1/2"	266	351	249	545	630	149	382	460	640
2HM5	R 2"	R 1 1/2"	291	376	249	570	655	149	382	460	640
2HM7	R 2"	R 1 1/2"	316	401	308	654	739	141	374	452	640
4HM4	R 2"	R 1 1/2"	241	326	249	520	605	149	382	460	640
4HM5	R 2"	R 1 1/2"	266	351	249	545	630	149	382	460	640
4HM7	R 2"	R 1 1/2"	291	376	308	629	714	141	374	452	640
4HM9	R 2"	R 1 1/2"	316	401	308	654	739	141	374	452	640
CEAM70/3	R 2"	R 1 1/2"	196	281	260	486	571	134	421	499	640
CEAM70/5	R 2"	R 1 1/2"	196	281	274	500	585	134	421	499	640
CEAM80/5	R 2"	R 1 1/2"	196	281	320	546	631	134	421	499	640
CEAM120/3	R 2"	R 2"	196	281	274	500	585	134	476	505	640
CEAM120/5	R 2"	R 2"	196	281	320	546	631	134	476	505	640
CEAM210/2	R 2" 1/2	R 2 1/2"	207	318	331	576	687	134	460	602	640
CEAM210/3	R 2" 1/2	R 2 1/2"	207	318	331	576	687	134	460	602	640
CEAM210/4	R 2" 1/2	R 2 1/2"	207	318	375	620	731	134	460	602	640
CEAM370/1	R 2" 1/2	R 2 1/2"	207	318	331	576	687	134	460	602	640
CEAM370/2	R 2" 1/2	R 2 1/2"	207	318	375	620	731	134	460	602	640
CAM70/33	R 2"	R 1 1/2"	276	361	289	595	680	128	435	513	640
CAM70/34	R 2"	R 1 1/2"	276	361	289	595	680	128	435	513	640
CAM70/45	R 2"	R 1 1/2"	276	361	289	595	680	128	435	513	640
CAM120/33	R 2"	R 2"	276	361	289	595	680	128	490	519	640
CAM120/35	R 2"	R 2"	276	361	289	595	680	128	490	519	640

gxs20_or-en_d_td

TWO-PUMP BOOSTER SETS, GXS20 RA SERIES HORIZONTAL ELECTRIC PUMPS WITH NON-RETURN VALVE ON SUCTION SIDE

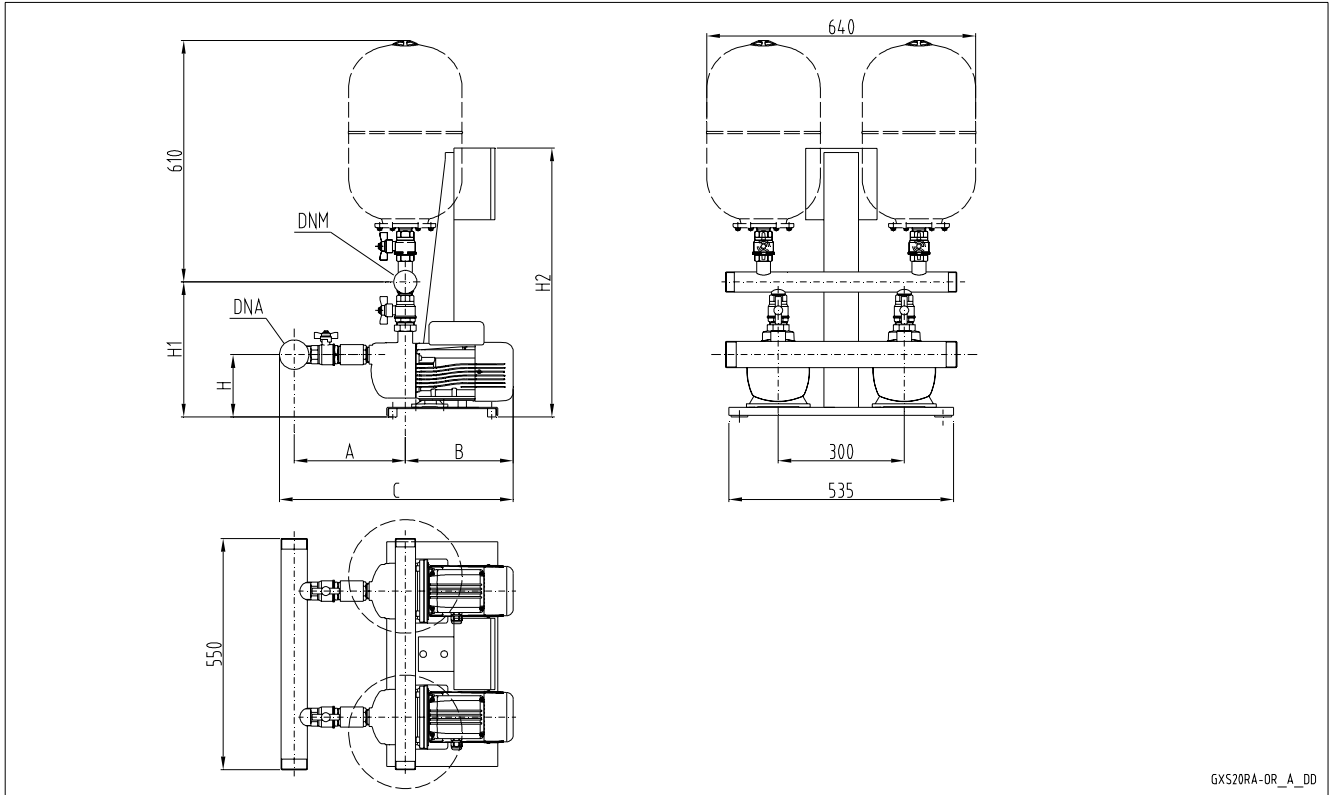

GXS20RA-OR_A_DD

GXS20

GXS 20RA	DNA	DNM	A		B	C		H	H1		H2
			STD / DW	AISI		STD / DW	AISI		STD / DW	AISI	
BGM3	R 2"	R 1 1/2"	267	445	297	594	772	189	371	454	640
BGM5	R 2"	R 1 1/2"	267	445	311	608	786	189	371	454	640
BGM7	R 2"	R 1 1/2"	267	445	356	653	831	189	371	454	640
BGM9	R 2"	R 1 1/2"	267	445	356	653	831	189	371	454	640
BGM11	R 2"	R 1 1/2"	267	445	356	653	831	189	371	454	640
2HM3	R 2"	R 1 1/2"	294	472	249	573	751	149	330	413	640
2HM4	R 2"	R 1 1/2"	319	497	249	598	776	149	330	413	640
2HM5	R 2"	R 1 1/2"	344	522	249	623	801	149	330	413	640
2HM7	R 2"	R 1 1/2"	369	547	308	707	885	141	322	405	640
4HM4	R 2"	R 1 1/2"	294	472	249	573	751	149	330	413	640
4HM5	R 2"	R 1 1/2"	319	497	249	598	776	149	330	413	640
4HM7	R 2"	R 1 1/2"	344	522	308	682	860	141	322	405	640
4HM9	R 2"	R 1 1/2"	369	547	308	707	885	141	322	405	640
CEAM70/3	R 2"	R 1 1/2"	249	427	260	539	717	134	369	452	640
CEAM70/5	R 2"	R 1 1/2"	249	427	274	553	731	134	369	452	640
CEAM80/5	R 2"	R 1 1/2"	249	427	320	599	777	134	369	452	640
CEAM120/3	R 2"	R 2"	249	427	274	553	731	134	375	458	640
CEAM120/5	R 2"	R 2"	249	427	320	599	777	134	375	458	640
CEAM210/2	R 2" 1/2"	R 2 1/2"	287	493	331	656	862	134	398	483	640
CEAM210/3	R 2" 1/2"	R 2 1/2"	287	493	331	656	862	134	398	483	640
CEAM210/4	R 2" 1/2"	R 2 1/2"	287	493	375	700	906	134	398	483	640
CEAM370/1	R 2" 1/2"	R 2 1/2"	287	493	331	656	862	134	398	483	640
CEAM370/2	R 2" 1/2"	R 2 1/2"	287	493	375	700	906	134	398	483	640
CAM70/33	R 2"	R 1 1/2"	329	507	289	648	826	128	383	466	640
CAM70/34	R 2"	R 1 1/2"	329	507	289	648	826	128	383	466	640
CAM70/45	R 2"	R 1 1/2"	329	507	289	648	826	128	383	466	640
CAM120/33	R 2"	R 2"	329	507	289	648	826	128	389	472	640
CAM120/35	R 2"	R 2"	329	507	289	648	826	128	389	472	640

gxs20ra_or-en_d_td

TWO-PUMP BOOSTER SETS, GXS20 SERIES VERTICAL ELECTRIC PUMPS WITH NON-RETURN VALVE ON DELIVERY SIDE

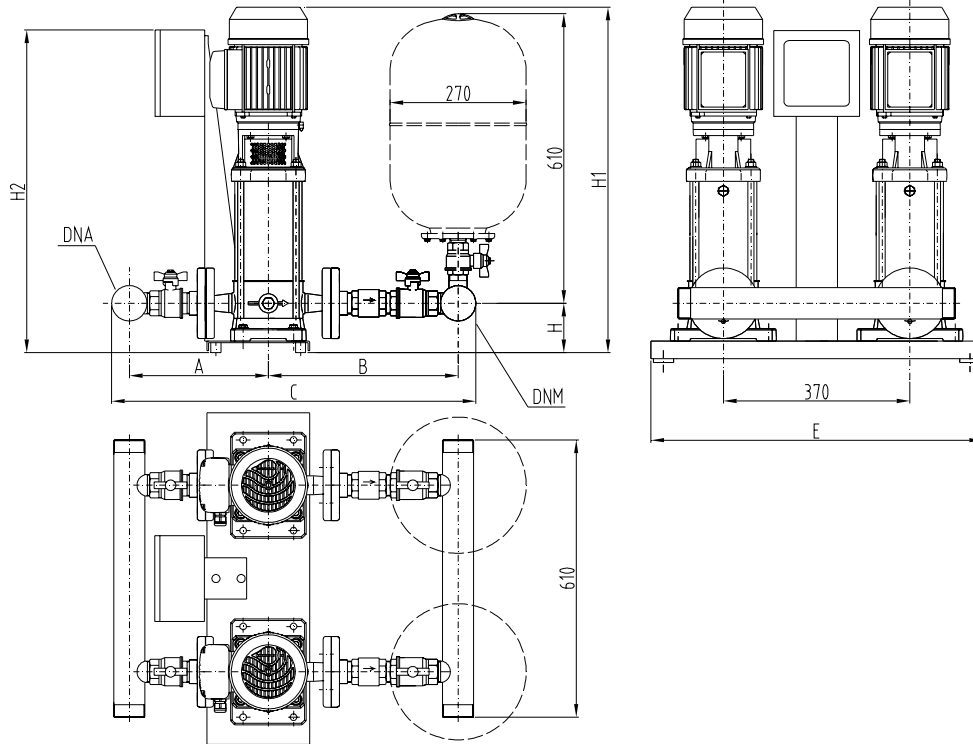

GXS20-SV_A_DD

GXS 20	DNA	DNM	A		B		C		E	H	H1	H2
			STD/DW	AISI	STD/DW	AISI	STD/DW	AISI				
3SV02F003M	R 2"	R 2"	252	301	304	346	616	707	658	98	510	629
3SV03F003M	R 2"	R 2"	252	301	304	346	616	707	658	98	510	629
3SV04F003M	R 2"	R 2"	252	301	304	346	616	707	658	98	530	629
3SV05F005M	R 2"	R 2"	252	301	304	346	616	707	658	98	572	629
3SV06F005M	R 2"	R 2"	252	301	304	346	616	707	658	98	592	629
3SV07F007M	R 2"	R 2"	252	301	304	346	616	707	658	98	654	629
3SV08F007M	R 2"	R 2"	252	301	304	346	616	707	658	98	674	629
3SV09F011M	R 2"	R 2"	252	301	304	346	616	707	658	98	694	629
3SV10F011M	R 2"	R 2"	252	301	304	346	616	707	658	98	714	629
3SV11F011M	R 2"	R 2"	252	301	304	346	616	707	658	98	734	629
3SV12F011M	R 2"	R 2"	252	301	304	346	616	707	658	98	754	629
3SV13F015M	R 2"	R 2"	252	301	304	346	616	707	658	98	784	629
3SV14F015M	R 2"	R 2"	252	301	304	346	616	707	658	98	804	629
3SV16F015M	R 2"	R 2"	252	301	304	346	616	707	658	98	844	629
5SV02F003M	R 2"	R 2"	265	311	327	431	652	802	658	98	500	629
5SV03F005M	R 2"	R 2"	265	311	327	431	652	802	658	98	547	629
5SV04F005M	R 2"	R 2"	265	311	327	431	652	802	658	98	572	629
5SV05F007M	R 2"	R 2"	265	311	327	431	652	802	658	98	639	629
5SV06F011M	R 2"	R 2"	265	311	327	431	652	802	658	98	664	629
5SV07F011M	R 2"	R 2"	265	311	327	431	652	802	658	98	689	629
5SV08F011M	R 2"	R 2"	265	311	327	431	652	802	658	98	714	629
5SV09F015M	R 2"	R 2"	265	311	327	431	652	802	658	98	749	629
5SV10F015M	R 2"	R 2"	265	311	327	431	652	802	658	98	774	629
5SV11F015M	R 2"	R 2"	265	311	327	431	652	802	658	98	799	629
10SV01F007M	R 2 1/2	R 2 1/2	297	356	362	497	735	929	682	114	654	640
10SV02F007M	R 2 1/2	R 2 1/2	297	356	362	497	735	929	682	114	654	640
10SV03F011M	R 2 1/2	R 2 1/2	297	356	362	497	735	929	682	114	686	640
10SV04F015M	R 2 1/2	R 2 1/2	297	356	362	497	735	929	682	114	728	640

Dimensions in mm. Tolerance ± 10 mm.

gxs20_esv-f-en_a_td

TWO-PUMP BOOSTER SETS, GXS20 RA SERIES VERTICAL ELECTRIC PUMPS WITH NON-RETURN VALVE ON SUCTION SIDE

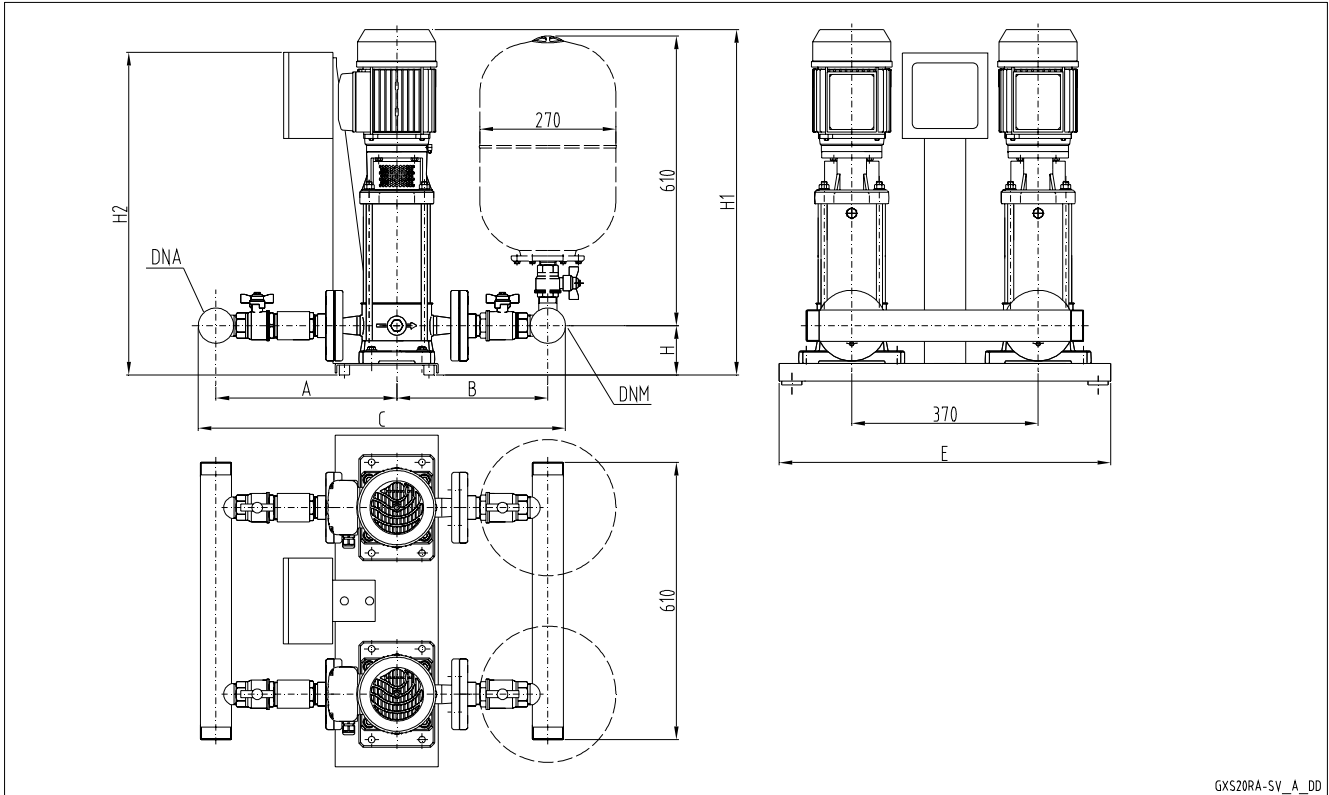

GXS20RA-SV_A_DD

GXS20

GXS 20RA	DNA	DNM	A		B		C		E	H	H1	H2
			STD/DW	AISI	STD/DW	AISI	STD/DW	AISI				
3SV02F003M	R 2"	R 2"	297	439	287	301	644	800	658	98	510	629
3SV03F003M	R 2"	R 2"	297	439	287	301	644	800	658	98	510	629
3SV04F003M	R 2"	R 2"	297	439	287	301	644	800	658	98	530	629
3SV05F005M	R 2"	R 2"	297	439	287	301	644	800	658	98	572	629
3SV06F005M	R 2"	R 2"	297	439	287	301	644	800	658	98	592	629
3SV07F007M	R 2"	R 2"	297	439	287	301	644	800	658	98	654	629
3SV08F007M	R 2"	R 2"	297	439	287	301	644	800	658	98	674	629
3SV09F011M	R 2"	R 2"	297	439	287	301	644	800	658	98	694	629
3SV10F011M	R 2"	R 2"	297	439	287	301	644	800	658	98	714	629
3SV11F011M	R 2"	R 2"	297	439	287	301	644	800	658	98	734	629
3SV12F011M	R 2"	R 2"	297	439	287	301	644	800	658	98	754	629
3SV13F015M	R 2"	R 2"	297	439	287	301	644	800	658	98	784	629
3SV14F015M	R 2"	R 2"	297	439	287	301	644	800	658	98	804	629
3SV16F015M	R 2"	R 2"	297	439	287	301	644	800	658	98	844	629
5SV02F003M	R 2"	R 2"	318	458	313	311	691	829	658	98	500	629
5SV03F005M	R 2"	R 2"	318	458	313	311	691	829	658	98	547	629
5SV04F005M	R 2"	R 2"	318	458	313	311	691	829	658	98	572	629
5SV05F007M	R 2"	R 2"	318	458	313	311	691	829	658	98	639	629
5SV06F011M	R 2"	R 2"	318	458	313	311	691	829	658	98	664	629
5SV07F011M	R 2"	R 2"	318	458	313	311	691	829	658	98	689	629
5SV08F011M	R 2"	R 2"	318	458	313	311	691	829	658	98	714	629
5SV09F015M	R 2"	R 2"	318	458	313	311	691	829	658	98	749	629
5SV10F015M	R 2"	R 2"	318	458	313	311	691	829	658	98	774	629
5SV11F015M	R 2"	R 2"	318	458	313	311	691	829	658	98	799	629
10SV01F007M	R 2 1/2"	R 2 1/2"	367	497	345	356	788	929	682	114	654	640
10SV02F007M	R 2 1/2"	R 2 1/2"	367	497	345	356	788	929	682	114	654	640
10SV03F011M	R 2 1/2"	R 2 1/2"	367	497	345	356	788	929	682	114	686	640
10SV04F015M	R 2 1/2"	R 2 1/2"	367	497	345	356	788	929	682	114	728	640

Dimensions in mm. Tolerance ± 10 mm.

gxs20ra_esv-f-en_a_td

TWO-PUMP BOOSTER SETS, GXS20 SERIES VERTICAL ELECTRIC PUMPS WITH NON-RETURN VALVE ON DELIVERY SIDE

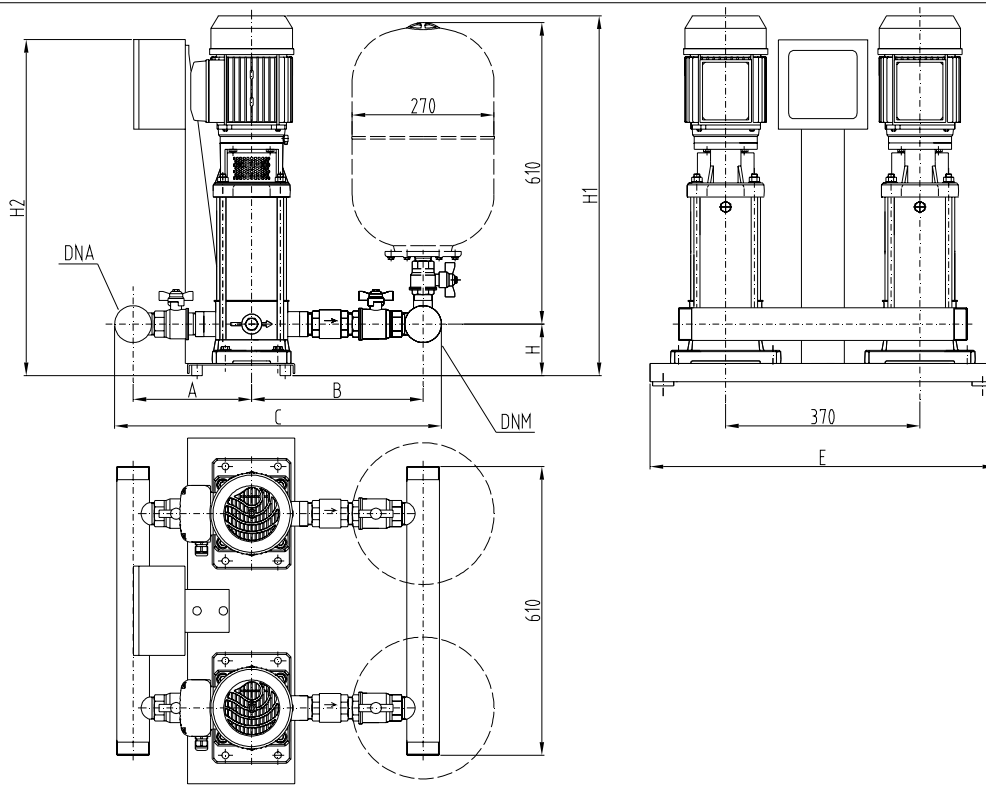

GXS20-SV_B_DD

GXS 20	DNA	DNM	A		B		C		E	H	H1	H2
			STD/DW	AISI	STD/DW	AISI	STD/DW	AISI				
3SV02T003M	R 2"	R 2"	233	312	285	367	578	739	658	73	485	629
3SV03T003M	R 2"	R 2"	233	312	285	367	578	739	658	73	485	629
3SV04T003M	R 2"	R 2"	233	312	285	367	578	739	658	73	505	629
3SV05T005M	R 2"	R 2"	233	312	285	367	578	739	658	73	547	629
3SV06T005M	R 2"	R 2"	233	312	285	367	578	739	658	73	567	629
3SV07T007M	R 2"	R 2"	233	312	285	367	578	739	658	73	629	629
3SV08T007M	R 2"	R 2"	233	312	285	367	578	739	658	73	649	629
3SV09T011M	R 2"	R 2"	233	312	285	367	578	739	658	73	669	629
3SV10T011M	R 2"	R 2"	233	312	285	367	578	739	658	73	689	629
3SV11T011M	R 2"	R 2"	233	312	285	367	578	739	658	73	709	629
3SV12T011M	R 2"	R 2"	233	312	285	367	578	739	658	73	729	629
3SV13T015M	R 2"	R 2"	233	312	285	367	578	739	658	73	759	629
3SV14T015M	R 2"	R 2"	233	312	285	367	578	739	658	73	779	629
3SV16T015M	R 2"	R 2"	233	312	285	367	578	739	658	73	819	629
5SV02T003M	R 2"	R 2"	248	336	310	403	618	799	658	73	475	629
5SV03T005M	R 2"	R 2"	248	336	310	403	618	799	658	73	522	629
5SV04T005M	R 2"	R 2"	248	336	310	403	618	799	658	73	547	629
5SV05T007M	R 2"	R 2"	248	336	310	403	618	799	658	73	614	629
5SV06T011M	R 2"	R 2"	248	336	310	403	618	799	658	73	639	629
5SV07T011M	R 2"	R 2"	248	336	310	403	618	799	658	73	664	629
5SV08T011M	R 2"	R 2"	248	336	310	403	618	799	658	73	689	629
5SV09T015M	R 2"	R 2"	248	336	310	403	618	799	658	73	724	629
5SV10T015M	R 2"	R 2"	248	336	310	403	618	799	658	73	749	629
5SV11T015M	R 2"	R 2"	248	336	310	403	618	799	658	73	774	629
10SV01T007M	R 2 1/2"	R 2 1/2"	291	386	356	471	723	933	682	114	654	640
10SV02T007M	R 2 1/2"	R 2 1/2"	291	386	356	471	723	933	682	114	654	640
10SV03T011M	R 2 1/2"	R 2 1/2"	291	386	356	471	723	933	682	114	686	640
10SV04T015M	R 2 1/2"	R 2 1/2"	291	386	356	471	723	933	682	114	728	640

Dimensions in mm. Tolerance ± 10 mm.

gxs20_esv-t-en_a_td

TWO-PUMP BOOSTER SETS, GXS20 RA SERIES VERTICAL ELECTRIC PUMPS WITH NON-RETURN VALVE ON SUCTION SIDE

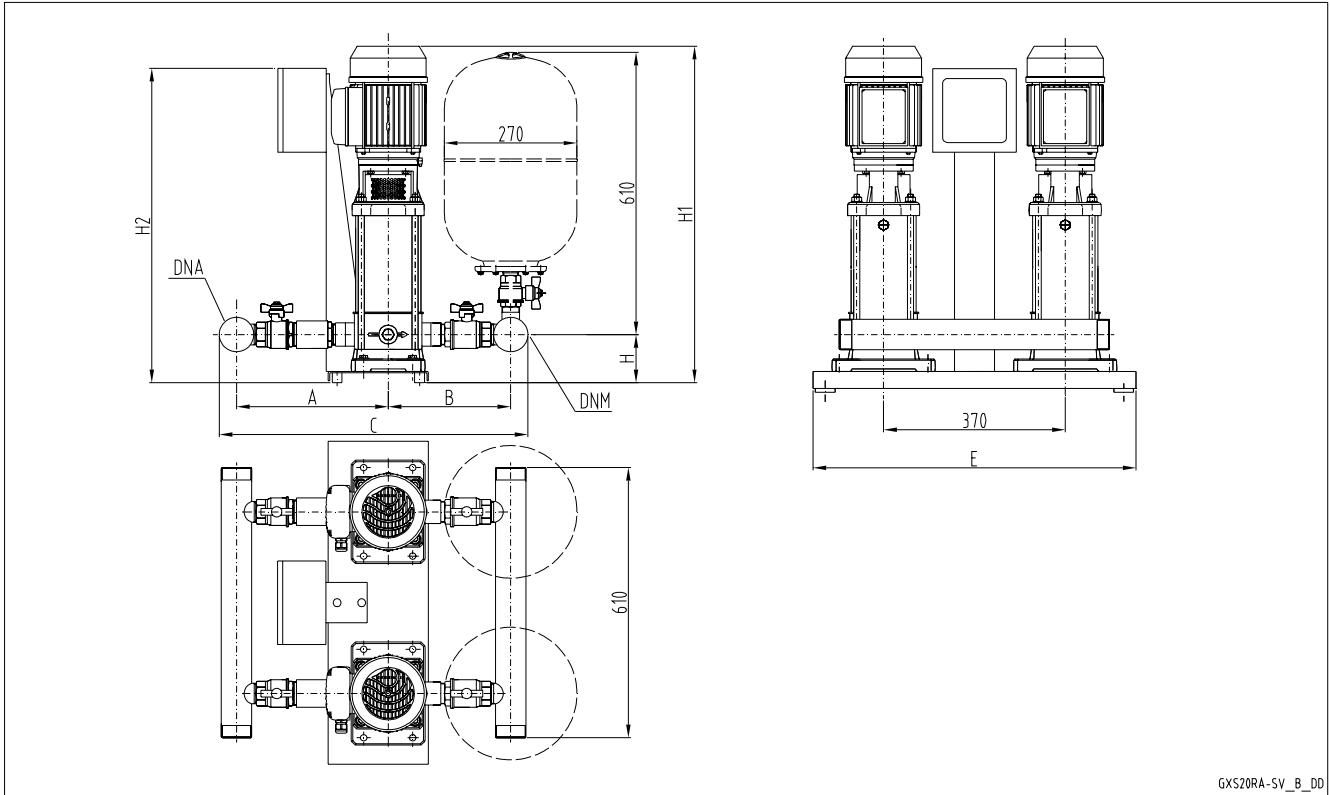

GXS20RA-SV_B_DD

GXS20

GXS 20RA	DNA	DNM	A		B		C		E	H	H1	H2
			STD/DW	AISI	STD/DW	AISI	STD/DW	AISI				
3SV02T003M	R 2"	R 2"	285	367	268	312	613	739	658	73	485	629
3SV03T003M	R 2"	R 2"	285	367	268	312	613	739	658	73	485	629
3SV04T003M	R 2"	R 2"	285	367	268	312	613	739	658	73	505	629
3SV05T005M	R 2"	R 2"	285	367	268	312	613	739	658	73	547	629
3SV06T005M	R 2"	R 2"	285	367	268	312	613	739	658	73	567	629
3SV07T007M	R 2"	R 2"	285	367	268	312	613	739	658	73	629	629
3SV08T007M	R 2"	R 2"	285	367	268	312	613	739	658	73	649	629
3SV09T011M	R 2"	R 2"	285	367	268	312	613	739	658	73	669	629
3SV10T011M	R 2"	R 2"	285	367	268	312	613	739	658	73	689	629
3SV11T011M	R 2"	R 2"	285	367	268	312	613	739	658	73	709	629
3SV12T011M	R 2"	R 2"	285	367	268	312	613	739	658	73	729	629
3SV13T015M	R 2"	R 2"	285	367	268	312	613	739	658	73	759	629
3SV14T015M	R 2"	R 2"	285	367	268	312	613	739	658	73	779	629
3SV16T015M	R 2"	R 2"	285	367	268	312	613	739	658	73	819	629
5SV02T003M	R 2"	R 2"	310	403	296	336	666	799	658	73	475	629
5SV03T005M	R 2"	R 2"	310	403	296	336	666	799	658	73	522	629
5SV04T005M	R 2"	R 2"	310	403	296	336	666	799	658	73	547	629
5SV05T007M	R 2"	R 2"	310	403	296	336	666	799	658	73	614	629
5SV06T011M	R 2"	R 2"	310	403	296	336	666	799	658	73	639	629
5SV07T011M	R 2"	R 2"	310	403	296	336	666	799	658	73	664	629
5SV08T011M	R 2"	R 2"	310	403	296	336	666	799	658	73	689	629
5SV09T015M	R 2"	R 2"	310	403	296	336	666	799	658	73	724	629
5SV10T015M	R 2"	R 2"	310	403	296	336	666	799	658	73	749	629
5SV11T015M	R 2"	R 2"	310	403	296	336	666	799	658	73	774	629
10SV01T007M	R 2 1/2"	R 2 1/2"	356	471	339	386	771	933	682	114	654	640
10SV02T007M	R 2 1/2"	R 2 1/2"	356	471	339	386	771	933	682	114	654	640
10SV03T011M	R 2 1/2"	R 2 1/2"	356	471	339	386	771	933	682	114	686	640
10SV04T015M	R 2 1/2"	R 2 1/2"	356	471	339	386	771	933	682	114	728	640

Dimensions in mm. Tolerance ± 10 mm.

gxs20ra_esv-t-en_a_td

Booster sets

MARKET SECTORS

CIVIL, INDUSTRIAL

APPLICATIONS

- Water network supply in condominiums, offices, hotels, shopping centres, factories.
- Water supply to agricultural water networks (e.g. irrigation).

GMD20 Series



GMD20

SPECIFICATIONS

- **Flow rate** up to 62 m³/h.
- **Head** up to 160 m.
- Electrical panel supply voltage: 3 x 400V ± 10%.
- Frequency: 50 Hz.
- Protection class electrical panel IP 54.
- Maximum electric pump power 2 x 4 kW.
- Direct motor start.
- Maximum temperature of pumped liquid:
from 0 to +80° C (for BG, CEA, CA, SV).
from 0 to +60° C (for HMT, HMZT).
- **Horizontal design pump:**
BG-CEA-CA-HMT-HMZT series.
Maximum operating pressure 8 bar.
- **Vertical design pump:**
SV..T series.
Maximum operating pressure 16 bar.

TWO-PUMP BOOSTER SETS, GMD20 SERIES IDENTIFICATION CODE

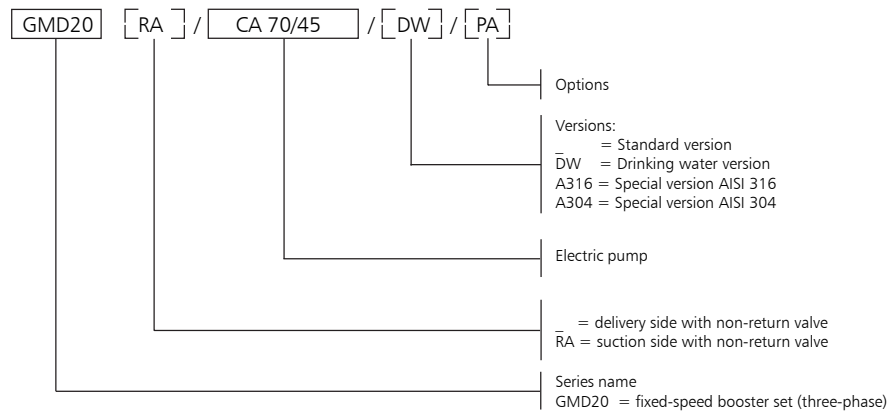

OPTIONS (ON DEMAND)

- 230 Power supply of control panel 3 x 230V. For different voltage supply, see control panel section.
- 3A Booster set with electric pump certified 1A (Factory test reports issued by the end of assembly line; it includes QH curve).
- 3B Booster set with electric pump certified 1B (Test report issued by Audit Test Lab; it includes QH curve, efficiency and power).
- 60 Booster set with 60Hz supply voltage.
- BAP High pressure switch installed on the delivery manifold.
- C9 Delivery manifold at 90° with bend. The tanks can not be installed directly on the manifold.
- CM Suction or delivery manifold larger than standard size.
- CP Dry contact version: power line, Automatic/Manual mode, Run/Stop for each pump, thermal block.
- IP55 Control panel IP55.
- IP65 IP65 version control panel.
- KV Kit voltmeter.
- MA Pressure gauge installed on suction manifold.
- NL Dutch market version.
- ORG With Real time clock inside the panel.
- PA Minimum pressure gauge installed on the suction manifold for dry-running protection.
- PQ Booster set with high suction pressure (pressure gauge/pressure switches/pressure transmitter increased of one range).
- RA Non return valves mounted on suction side (I.e GMD20RA/SV...).
- RE Heaters inside the control panel, with thermostat.
- RV Electric panel with phase sequence, phase loss, over- and undervoltage and phase unbalance.
- SA No intake: no suction valves and suction manifold.
- SC Group with no control devices, such as pressure switches and transmitters; the pressure gauge is present.
- SCA No suction manifold (suction valves present).
- SCM Without delivery manifold (no pressure transmitters and pressure gauge, with delivery valves).
- SM Without delivery: without valves on delivery and without delivery manifold.
- TS Booster set with pumps equipped with special mechanical seals.
- UK UK market version.
- VA Electric control panel fitted with analogue voltmeter and ammeter.
- WM Wall-mounted electrical panel with fixing tabs. Cables L= 5m

AVAILABLE VERSIONS

- A304 Main component in contact with liquid in stainless steel Aisi 304 or superior; gasket, sealing tape and thread sealing are suitable for drinking water. Bolts and screws galvanized. Flanges not in contact with the liquid in galvanized steel.
- B304 Main component in contact with liquid in stainless steel Aisi 304 or superior; gasket, sealing tape and thread sealing are suitable for drinking water. Bolts and screws in Aisi 304 or superior. Flanges not in contact with the liquid in Aisi 304 or superior.
- C304 Main component in contact with liquid in stainless steel Aisi 304 or superior; gasket, sealing tape and thread sealing are suitable for drinking water. Baseplate, frame, supports, bolts and screws in Aisi 304 or superior. Flanges not in contact with the liquid in Aisi 304 or superior. Valves and their components completely in Aisi 304 or superior (body, disc, plate).
- A316 Main component in contact with liquid in stainless steel Aisi 316; gasket, sealing tape and thread sealing are suitable for drinking water. Pumps in Aisi 316 material. Bolts and screws galvanized. Flanges not in contact with the liquid in galvanized steel.
- B316 Main component in contact with liquid in stainless steel Aisi 316; gasket, sealing tape and thread sealing are suitable for drinkingwater. Pumps in Aisi 316 material. Bolts and screws in Aisi 316. Flanges not in contact with the liquid in Aisi 316.
- C316 Main component in contact with liquid in stainless steel Aisi 316; gasket, sealing tape and thread sealing are suitable for drinking water. Pumps in Aisi 316 material. Baseplate, frame, supports, bolts and screws in Aisi 316. Flanges not in contact with the liquid in Aisi 316. Valves and their components completely in Aisi 316 (body, disc, plate).
- DW Main component in contact with fluid suitable for drinking water or in stainless steel AISI 304 or superior quality.

TWO-PUMP BOOSTER SETS, GMD20 SERIES OPERATING CHARACTERISTICS AND LIMITS

Liquids handled	Water containing no gas or corrosive and/or aggressive substances.
Fluid temperature	Depending on the type of pump: SV..T, CEA, CA: da oltre -10°C a + 80 °C. HMT, HMZT: da oltre -10°C a + 60 °C.
Ambient temperature	Above 0°C a + 40 °C.
Maximum operating pressure	Max 8 bar, 10 bar, 16 bar Depending on the type of pump.
Minimum inlet pressure	According to NPSH curve and losses, with a minimum margin of 0.5 m.
Maximum inlet pressure	The inlet pressure added to the pressure of the pump at zero flow must be lower than the maximum operating pressure of the set
Hourly starts (single pump)	Max 60 up to 3 kW, above 3 kW and up to 4 kW max 40.
Installation	Indoors, protected from the weather. Away from heat sources. Max elevation 1000 m ASL. Max humidity 50% without condensation.
Sound emission	Sound emission level Lp < 70 dB(A) for two-pump set with 2900 rpm motor with power up to 2 x 4 kW.

gmd20-en_2p_a_ti

TABLE OF MATERIALS

NAME	MATERIAL			
	(STANDARD)	DW	A304	A316
Manifolds	AISI 304	AISI 304	AISI 304	AISI 316
On-off valves	Nickel-plated brass	Nickel-plated brass	AISI 316	AISI 316
Non-return valves	Brass	Brass	AISI 304	AISI 316
Pressure switches	Chrome plated zinc alloy	AISI 304	AISI 304	AISI 304
Pressure trasmitter	AISI 316	AISI 316	AISI 316	AISI 316
Caps/plugs/flanges	Galvanized steel	AISI 304	AISI 304	AISI 316
Bracket	Galvanized steel	Galvanized steel	Galvanized steel	Galvanized steel
Base	Galvanized steel	Galvanized steel	Galvanized steel	Galvanized steel
Pump Body	AISI 304	AISI 304	AISI 304	AISI 316(*)

* Not all models of electric pumps are available in AISI 316. Consult technical catalog of pump.

gmd20_2p-en_a_tm

TWO-PUMP BOOSTER SETS, GMD20 SERIES MAIN COMPONENTS

- **Main On-off valves** on suction and discharge side of each pump, ball type with threaded coupling.
- **Check valve** on discharge side of each pump, spring-loaded type, with threaded coupling. For applications with air-cushion surge tanks, they are mounted on the suction side and the set is equipped with a connector for G 1/2" threaded flexible air feeder pipe (serie GMD20..RA).
- **Suction manifold** made of galvanized or AISI 304 stainless steel with threaded ends. Threaded coupling for water charging.
- **Delivery manifold** made of galvanized or AISI 304 stainless steel with threaded ends. Fitted with R1" threaded couplings with caps to allow connection of 24 or 20-litre diaphragm pressure vessels.
- **Pressure gauge and 2 control transmitters** located on the delivery side of the unit.
- **Various couplings** in nickel-plated brass, galvanized steel or stainless steel depending on the version.
- **Mounting base**, for pumpset and panel mounting brackets in galvanized steel.
- **Electric control panel**, IP54 protection class.

STANDARD VERSIONS AVAILABLE

See table of materials.

STANDARD VERSION

For general applications

Valves in brass or nickel plated brass, galvanized steel or brass fittings.

DW VERSION (GMD20../DW)

For drinking water applications.

The main components in contact with the liquid are certified suitable for drinking water or are made of AISI 304 or higher grade of stainless steel.

AISI304 Version (GMD20../A304), AISI 316 (GMD20../A316)

For special applications

Manifolds, valves, non-return valves and main components with parts directly in contact with the pumped liquid are made of AISI 304 or AISI 316 stainless steel.

Accessories available on request:

- Devices **against dry running** in one of the following versions:
 - float switch, for positive suction head;
 - probe electrodes kit, for positive suction head;
 - minimum pressure switch, for positive suction head.
- **Surge tank** in the following versions:
 - Air-cushion surge tank with compressor and accessories for surge tank and compressor.
 - Diaphragm vessel as an alternative to the air-cushion tank.
- **Kit featuring** a 24 or 20-litre **diaphragm expansion vessel** with ball valve (one for each pump), in the following versions, depending on the maximum head of the pumps:
 - 24-litre 8 bar cylinder water vessel kit
 - 24-litre 10 bar cylinder water vessel kit
 - 24-litre 16 bar cylinder water vessel kit
 - 20-litre 25 bar cylinder water vessel kit
- **Alarm kit**;
- **Air feeder** for **RA** version.

SPECIAL VERSIONS AVAILABLE ON REQUEST

(Contact the Sales and technical Assistance Service)

- Support base in AISI 304, AISI 316 stainless steel.
- Units with stainless steel expansion vessels.
- Units with special valves.
- Sets with jockey pump.
- Booster sets with NO-standard voltage supply, for instance: 3 x 440 V.

TWO-PUMP BOOSTER SETS, GMD20 SERIES CONTROL PANEL

Electric panel, three-phase power supply, for controlling and protecting up to two three-phase electric pumps, with case made from sheet steel (fig. 1) and protected to IP54.

Main characteristics:

- Main door-lock switch, fuse holders and fuses, starting contactors and thermal protection such as overload protectors for each motor.
- Standard supply voltage: 3x400Vac +/-10%, 50/60Hz. Non standard voltages on request, 3x230Vac +/-10%, 3x440Vac +/-10%, 3x460Vac +/-10%, 3x480Vac +/-10%, 50/60Hz.
- Transformer for low voltage auxiliary circuit; auxiliary voltage 24 Vac.
- Lowara SM20 digital control unit (see fig. 2), offers the following functions:
 - Indicator LED's: power on (ref. 1), thermal protection cut-in (ref. 2), no-water level alarm (ref. 3), pump running (ref. 4).
 - Automatic / manual operation buttons (ref. 5) and indicator LED's (ref. 6).
 - Manual pump stop/start (one button for each pump) (ref. 7).
 - Automatic cascade pump control with two pressure switches (one for each pump).
 - Jockey pump management by disabling cycle reversal.
 - Cycle reversal function (can be disabled). Automatically switches pumps after every start/stop cycle.
 - Automatic, manual or disabled mode switches for each pump (inside board). Only to be used if a board fault develops in order to assure pump operation.
 - No-water protection system alternatives: float, minimum pressure switch, external contact or electrode probes with sensitivity adjustment.
 - Adjustable timer delaying tripping of the no-water protection system (inside board); can be adjusted from 0 to 30 seconds.
 - Adjustable timer extending the operation of each pump (inside board); can be adjusted from 0 to 100 sec.
 - A relay board (optional) can be installed on the board to boost the following signals: pump 1,2 running, manual mode, overload alarm, no-water alarm, power on.
- External enable connection or pressure switch for maximum pressure protection.



Fig.1 - QMD electrical panel

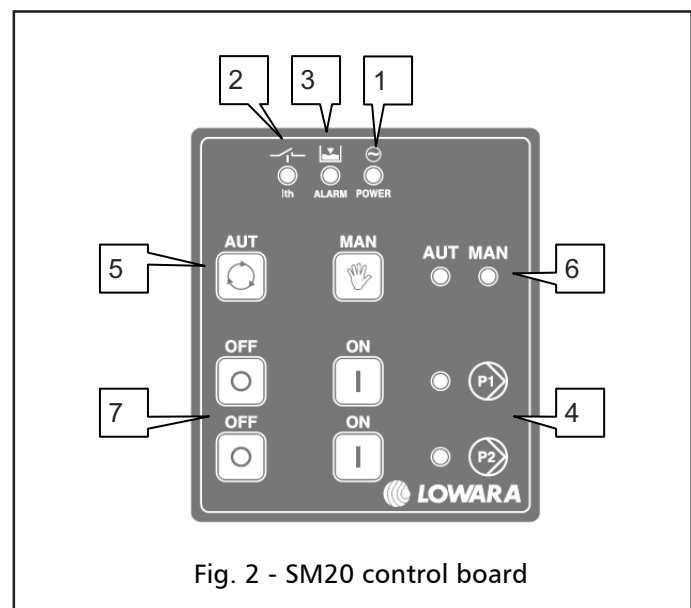
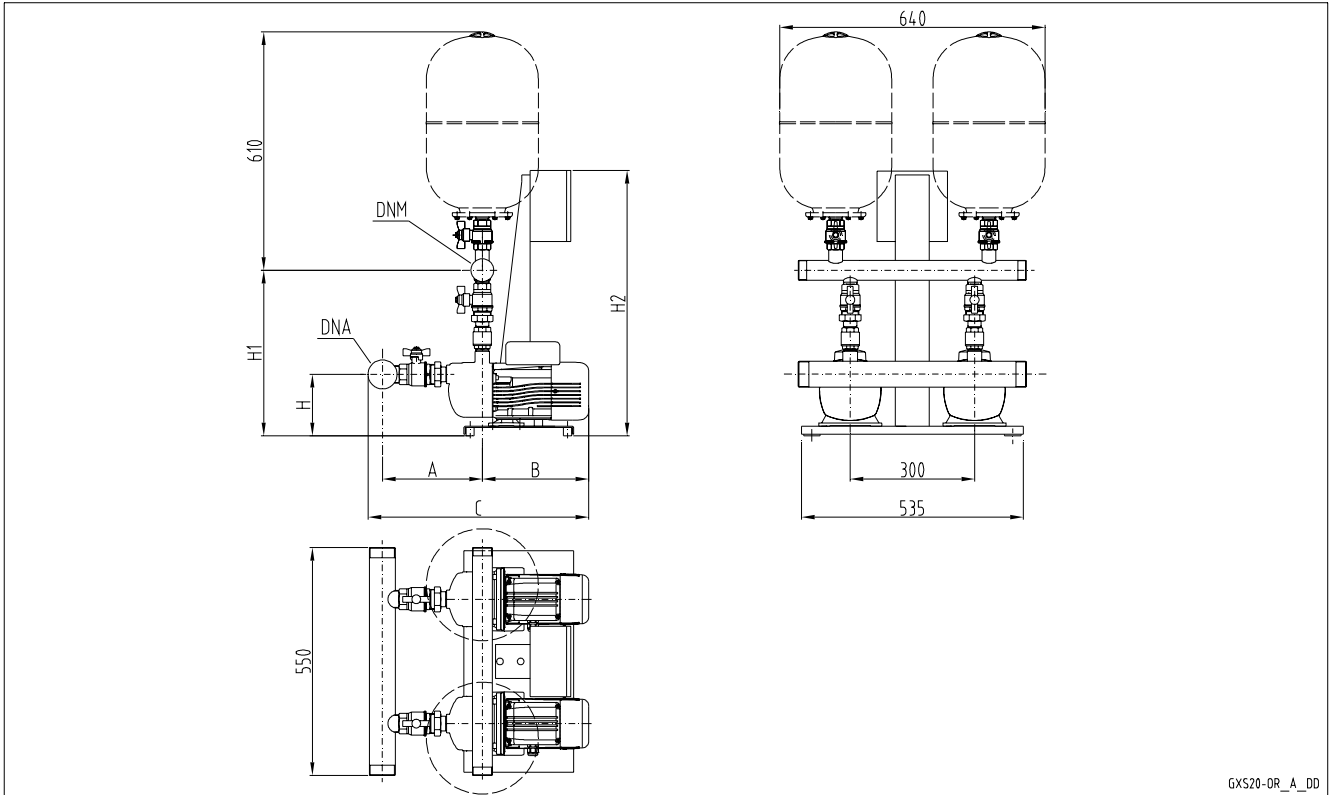

Fig. 2 - SM20 control board

TWO-PUMP BOOSTER SETS, GMD20 SERIES HORIZONTAL ELECTRIC PUMPS WITH NON-RETURN VALVE ON DELIVERY SIDE

GMD20



GXS20-OR_A_DD

GMD 20	DNA	DNM	A		B	C		H	H1		H2
			STD / DW	AISI		STD / DW	AISI		STD / DW	AISI	
BG3	R 2"	R 1 1/2"	214	299	297	541	626	189	423	501	640
BG5	R 2"	R 1 1/2"	214	299	311	555	640	189	423	501	640
BG7	R 2"	R 1 1/2"	214	299	356	600	685	189	423	501	640
BG9	R 2"	R 1 1/2"	214	299	356	600	685	189	423	501	640
BG11	R 2"	R 1 1/2"	214	299	356	600	685	189	423	501	640
2HM3T	R 2"	R 1 1/2"	241	326	249	520	605	149	382	460	640
2HM4T	R 2"	R 1 1/2"	266	351	249	545	630	149	382	460	640
2HM5T	R 2"	R 1 1/2"	291	376	249	570	655	149	382	460	640
2HM7T	R 2"	R 1 1/2"	316	401	308	654	739	141	374	452	640
4HM4T	R 2"	R 1 1/2"	241	326	249	520	605	149	382	460	640
4HM5T	R 2"	R 1 1/2"	266	351	249	545	630	149	382	460	640
4HM7T	R 2"	R 1 1/2"	291	376	308	629	714	141	374	452	640
4HM9T	R 2"	R 1 1/2"	316	401	308	654	739	141	374	452	640
CEA70/3	R 2"	R 1 1/2"	196	281	260	486	571	134	421	499	640
CEA70/5	R 2"	R 1 1/2"	196	281	274	500	585	134	421	499	640
CEA80/5	R 2"	R 1 1/2"	196	281	320	546	631	134	421	499	640
CEA120/3	R 2"	R 2"	196	281	274	500	585	134	476	505	640
CEA120/5	R 2"	R 2"	196	281	320	546	631	134	476	505	640
CEA210/2	R 2" 1/2	R 2" 1/2	207	318	331	576	687	134	460	602	640
CEA210/3	R 2" 1/2	R 2" 1/2	207	318	331	576	687	134	460	602	640
CEA210/4	R 2" 1/2	R 2" 1/2	207	318	375	620	731	134	460	602	640
CEA210/5	R 2" 1/2	R 2" 1/2	207	318	375	620	731	134	460	602	640
CEA370/1	R 2" 1/2	R 2" 1/2	207	318	331	576	687	134	460	602	640
CEA370/2	R 2" 1/2	R 2" 1/2	207	318	375	620	731	134	460	602	640
CEA370/3	R 2" 1/2	R 2" 1/2	207	318	375	620	731	134	460	602	640
CEA370/5	R 2" 1/2	R 2" 1/2	207	318	375	620	731	134	460	602	640
CA70/33	R 2"	R 1 1/2"	276	361	289	595	680	128	435	513	640
CA70/34	R 2"	R 1 1/2"	276	361	289	595	680	128	435	513	640
CA70/45	R 2"	R 1 1/2"	276	361	289	595	680	128	435	513	640
CA120/33	R 2"	R 2"	276	361	289	595	680	128	490	519	640
CA120/35	R 2"	R 2"	276	361	289	595	680	128	490	519	640
CA120/55	R 2"	R 2"	276	361	323	629	714	128	490	519	640
CA200/33	R 2" 1/2	R 2"	284	395	323	645	756	128	490	519	640
CA200/35	R 2" 1/2	R 2"	284	395	323	645	756	128	490	519	640
CA200/55	R 2" 1/2	R 2"	284	395	323	645	756	128	490	519	640

gmd20_or-en_d_td

TWO-PUMP BOOSTER SETS, GMD20 RA SERIES HORIZONTAL ELECTRIC PUMPS WITH NON-RETURN VALVE ON SUCTION SIDE

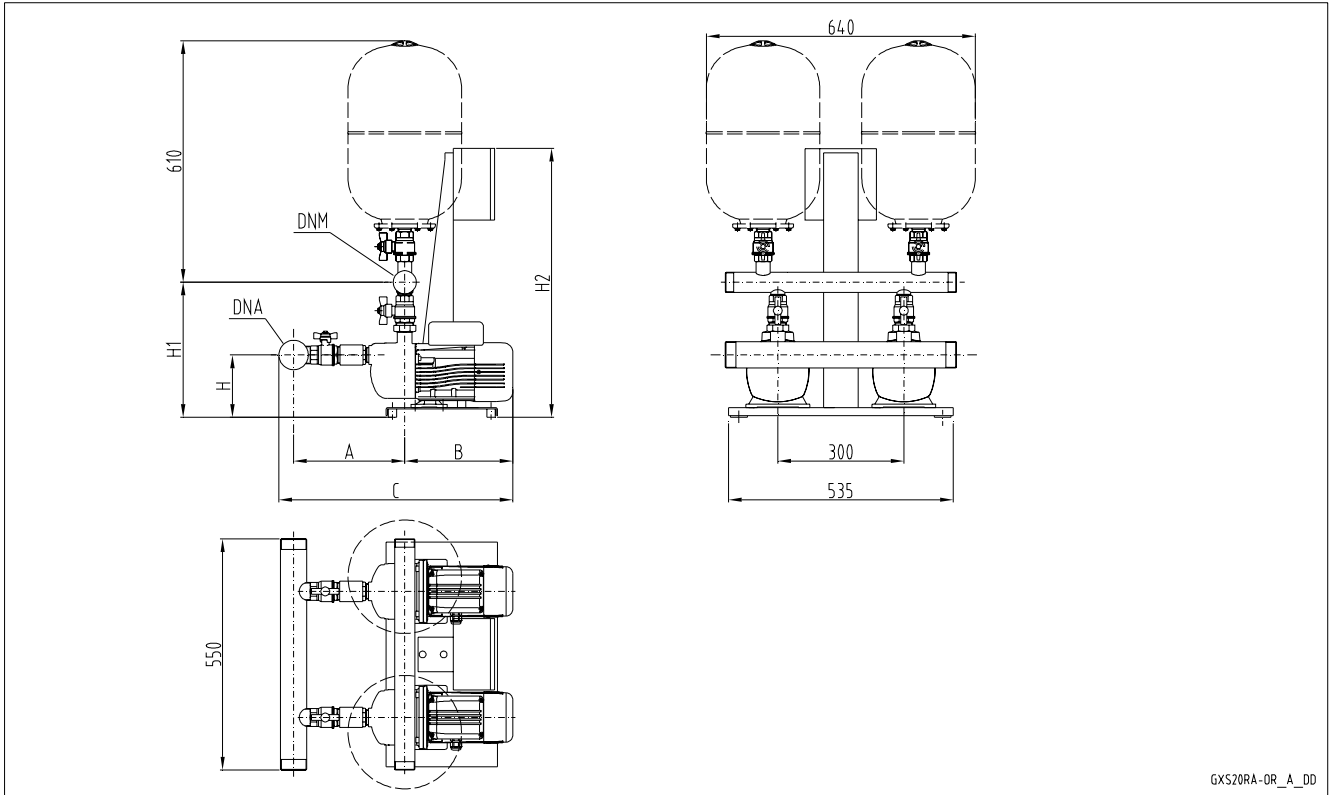

GXS20RA-OR_A_DD

GMD 20RA	DNA	DNM	A		B	C		H	H1		H2
			STD / DW	AISI		STD / DW	AISI		STD / DW	AISI	
BG3	R 2"	R 1 1/2"	267	445	297	594	772	189	371	454	640
BG5	R 2"	R 1 1/2"	267	445	311	608	786	189	371	454	640
BG7	R 2"	R 1 1/2"	267	445	356	653	831	189	371	454	640
BG9	R 2"	R 1 1/2"	267	445	356	653	831	189	371	454	640
BG11	R 2"	R 1 1/2"	267	445	356	653	831	189	371	454	640
2HM3T	R 2"	R 1 1/2"	294	472	249	573	751	149	330	413	640
2HM4T	R 2"	R 1 1/2"	319	497	249	598	776	149	330	413	640
2HM5T	R 2"	R 1 1/2"	344	522	249	623	801	149	330	413	640
2HM7T	R 2"	R 1 1/2"	369	547	308	707	885	141	322	405	640
4HM4T	R 2"	R 1 1/2"	294	472	249	573	751	149	330	413	640
4HM5T	R 2"	R 1 1/2"	319	497	249	598	776	149	330	413	640
4HM7T	R 2"	R 1 1/2"	344	522	308	682	860	141	322	405	640
4HM9T	R 2"	R 1 1/2"	369	547	308	707	885	141	322	405	640
CEA70/3	R 2"	R 1 1/2"	249	427	260	539	717	134	369	452	640
CEA70/5	R 2"	R 1 1/2"	249	427	274	553	731	134	369	452	640
CEA80/5	R 2"	R 1 1/2"	249	427	320	599	777	134	369	452	640
CEA120/3	R 2"	R 2"	249	427	274	553	731	134	375	458	640
CEA120/5	R 2"	R 2"	249	427	320	599	777	134	375	458	640
CEA210/2	R 2" 1/2	R 2 1/2"	287	493	331	656	862	134	398	483	640
CEA210/3	R 2" 1/2	R 2 1/2"	287	493	331	656	862	134	398	483	640
CEA210/4	R 2" 1/2	R 2 1/2"	287	493	375	700	906	134	398	483	640
CEA210/5	R 2" 1/2	R 2 1/2"	287	493	375	700	906	134	398	483	640
CEA370/1	R 2" 1/2	R 2 1/2"	287	493	331	656	862	134	398	483	640
CEA370/2	R 2" 1/2	R 2 1/2"	287	493	375	700	906	134	398	483	640
CEA370/3	R 2" 1/2	R 2 1/2"	287	493	375	700	906	134	398	483	640
CEA370/5	R 2" 1/2	R 2 1/2"	287	493	375	700	906	134	398	483	640
CA70/33	R 2"	R 1 1/2"	329	507	289	648	826	128	383	466	640
CA70/34	R 2"	R 1 1/2"	329	507	289	648	826	128	383	466	640
CA70/45	R 2"	R 1 1/2"	329	507	289	648	826	128	383	466	640
CA120/33	R 2"	R 2"	329	507	289	648	826	128	389	472	640
CA120/35	R 2"	R 2"	329	507	289	648	826	128	389	472	640
CA120/55	R 2"	R 2"	329	507	323	682	860	128	389	472	640
CA200/33	R 2" 1/2	R 2"	364	570	323	725	931	128	389	472	640
CA200/35	R 2" 1/2	R 2"	364	570	323	725	931	128	389	472	640
CA200/55	R 2" 1/2	R 2"	364	570	323	725	931	128	389	472	640

gmd20ra_or-en_e_td

**TWO-PUMP BOOSTER SETS, GMD20 SERIES
VERTICAL ELECTRIC PUMPS WITH NON-RETURN VALVE
ON DELIVERY SIDE**

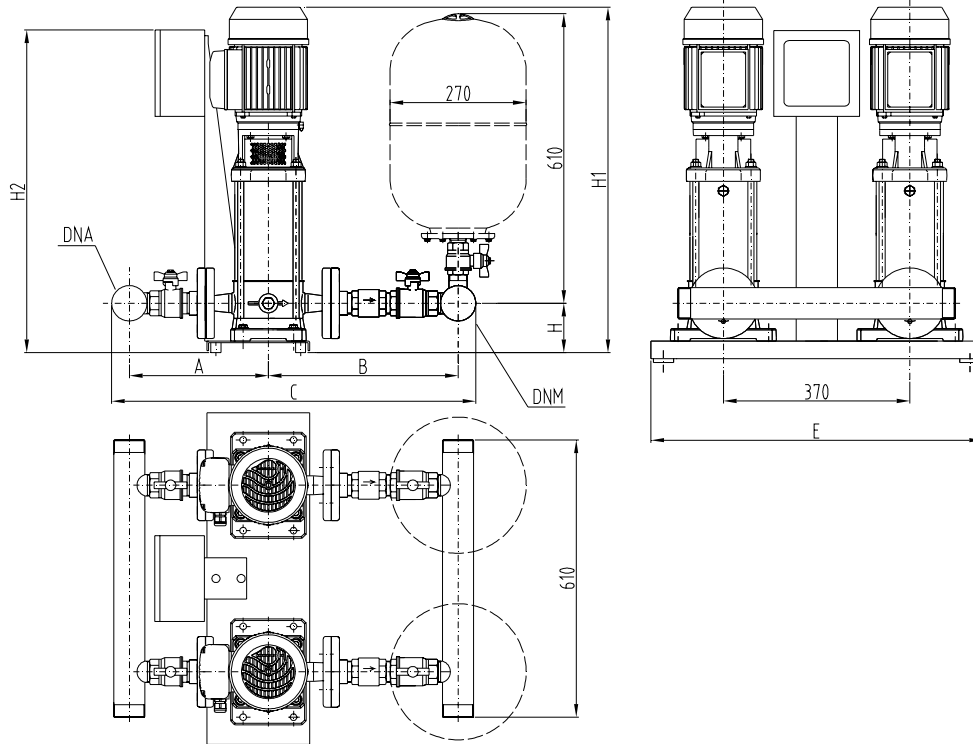

GXS20-SV_A_DD

GMD20

TWO-PUMP BOOSTER SETS, GMD20 SERIES VERTICAL ELECTRIC PUMPS WITH NON-RETURN VALVE ON DELIVERY SIDE

GMD 20	DNA	DNM	A		B		C		E	H	H1	H2
			STD/DW	AISI	STD/DW	AISI	STD/DW	AISI				
3SV02F003T	R 2"	R 2"	252	301	304	346	616	707	658	98	510	629
3SV03F003T	R 2"	R 2"	252	301	304	346	616	707	658	98	510	629
3SV04F003T	R 2"	R 2"	252	301	304	346	616	707	658	98	530	629
3SV05F005T	R 2"	R 2"	252	301	304	346	616	707	658	98	572	629
3SV06F005T	R 2"	R 2"	252	301	304	346	616	707	658	98	592	629
3SV07F007T	R 2"	R 2"	252	301	304	346	616	707	658	98	654	629
3SV08F007T	R 2"	R 2"	252	301	304	346	616	707	658	98	674	629
3SV09F011T	R 2"	R 2"	252	301	304	346	616	707	658	98	694	629
3SV10F011T	R 2"	R 2"	252	301	304	346	616	707	658	98	714	629
3SV11F011T	R 2"	R 2"	252	301	304	346	616	707	658	98	734	629
3SV12F011T	R 2"	R 2"	252	301	304	346	616	707	658	98	754	629
3SV13F015T	R 2"	R 2"	252	301	304	346	616	707	658	98	784	629
3SV14F015T	R 2"	R 2"	252	301	304	346	616	707	658	98	804	629
3SV16F015T	R 2"	R 2"	252	301	304	346	616	707	658	98	844	629
3SV19F022T	R 2"	R 2"	252	301	304	346	616	707	658	98	939	629
3SV21F022T	R 2"	R 2"	252	301	304	346	616	707	658	98	979	629
5SV02F003T	R 2"	R 2"	265	311	327	431	652	802	658	98	500	629
5SV03F005T	R 2"	R 2"	265	311	327	431	652	802	658	98	547	629
5SV04F005T	R 2"	R 2"	265	311	327	431	652	802	658	98	572	629
5SV05F007T	R 2"	R 2"	265	311	327	431	652	802	658	98	639	629
5SV06F011T	R 2"	R 2"	265	311	327	431	652	802	658	98	664	629
5SV07F011T	R 2"	R 2"	265	311	327	431	652	802	658	98	689	629
5SV08F011T	R 2"	R 2"	265	311	327	431	652	802	658	98	714	629
5SV09F015T	R 2"	R 2"	265	311	327	431	652	802	658	98	749	629
5SV10F015T	R 2"	R 2"	265	311	327	431	652	802	658	98	774	629
5SV11F015T	R 2"	R 2"	265	311	327	431	652	802	658	98	799	629
5SV12F022T	R 2"	R 2"	265	311	327	431	652	802	658	98	859	629
5SV13F022T	R 2"	R 2"	265	311	327	431	652	802	658	98	884	629
5SV14F022T	R 2"	R 2"	265	311	327	431	652	802	658	98	909	629
5SV15F022T	R 2"	R 2"	265	311	327	431	652	802	658	98	934	629
5SV16F022T	R 2"	R 2"	265	311	327	431	652	802	658	98	959	629
5SV18F030T	R 2"	R 2"	265	311	327	431	652	802	682	109	1030	640
5SV21F030T	R 2"	R 2"	265	311	327	431	652	802	682	109	1105	640
10SV01F007T	R 2"1/2	R 2"1/2	297	356	362	497	735	929	682	114	654	640
10SV02F007T	R 2"1/2	R 2"1/2	297	356	362	497	735	929	682	114	654	640
10SV03F011T	R 2"1/2	R 2"1/2	297	356	362	497	735	929	682	114	686	640
10SV04F015T	R 2"1/2	R 2"1/2	297	356	362	497	735	929	682	114	728	640
10SV05F022T	R 2"1/2	R 2"1/2	297	356	362	497	735	929	682	114	795	640
10SV06F022T	R 2"1/2	R 2"1/2	297	356	362	497	735	929	682	114	827	640
10SV07F030T	R 2"1/2	R 2"1/2	297	356	362	497	735	929	682	114	869	640
10SV08F030T	R 2"1/2	R 2"1/2	297	356	362	497	735	929	682	114	901	640
10SV09F040T	R 2"1/2	R 2"1/2	297	356	362	497	735	929	682	114	954	640
10SV10F040T	R 2"1/2	R 2"1/2	297	356	362	497	735	929	682	114	986	640
10SV11F040T	R 2"1/2	R 2"1/2	297	356	362	497	735	929	682	114	1018	640

Dimensions in mm. Tolerance ± 10 mm.

gmd20_esv-f-en_a_td

GMD20

**TWO-PUMP BOOSTER SETS, GMD20 RA SERIES
VERTICAL ELECTRIC PUMPS WITH NON-RETURN VALVE
ON SUCTION SIDE**

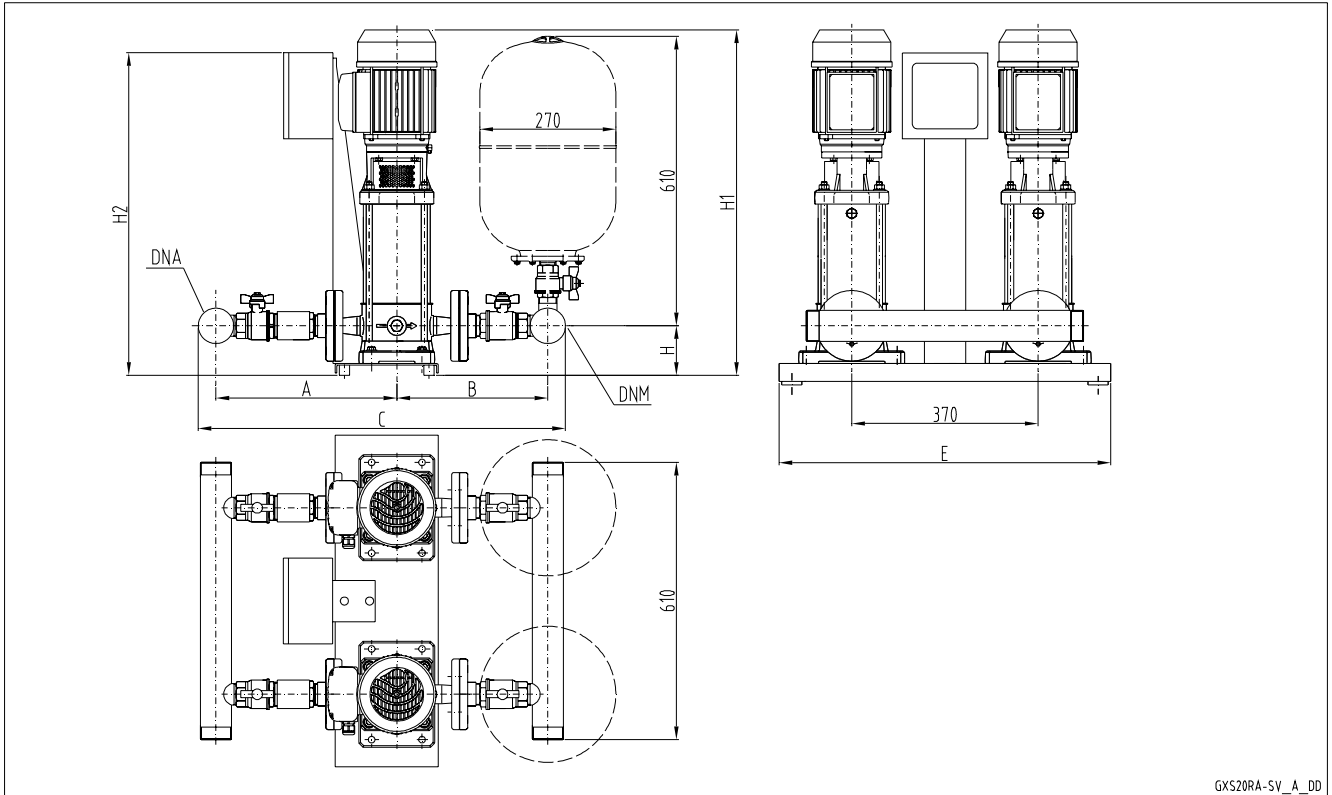

GXS20RA-SV_A_DD

GMD20

TWO-PUMP BOOSTER SETS, GMD20 RA SERIES VERTICAL ELECTRIC PUMPS WITH NON-RETURN VALVE ON SUCTION SIDE

GMD 20RA	DNA	DNM	A		B		C		E	H	H1	H2
			STD/DW	AISI	STD/DW	AISI	STD/DW	AISI				
3SV02F003T	R 2"	R 2"	297	439	287	301	644	800	658	98	510	629
3SV03F003T	R 2"	R 2"	297	439	287	301	644	800	658	98	510	629
3SV04F003T	R 2"	R 2"	297	439	287	301	644	800	658	98	530	629
3SV05F005T	R 2"	R 2"	297	439	287	301	644	800	658	98	572	629
3SV06F005T	R 2"	R 2"	297	439	287	301	644	800	658	98	592	629
3SV07F007T	R 2"	R 2"	297	439	287	301	644	800	658	98	654	629
3SV08F007T	R 2"	R 2"	297	439	287	301	644	800	658	98	674	629
3SV09F011T	R 2"	R 2"	297	439	287	301	644	800	658	98	694	629
3SV10F011T	R 2"	R 2"	297	439	287	301	644	800	658	98	714	629
3SV11F011T	R 2"	R 2"	297	439	287	301	644	800	658	98	734	629
3SV12F011T	R 2"	R 2"	297	439	287	301	644	800	658	98	754	629
3SV13F015T	R 2"	R 2"	297	439	287	301	644	800	658	98	784	629
3SV14F015T	R 2"	R 2"	297	439	287	301	644	800	658	98	804	629
3SV16F015T	R 2"	R 2"	297	439	287	301	644	800	658	98	844	629
3SV19F022T	R 2"	R 2"	297	439	287	301	644	800	658	98	939	629
3SV21F022T	R 2"	R 2"	297	439	287	301	644	800	658	98	979	629
5SV02F003T	R 2"	R 2"	318	458	313	311	691	829	658	98	500	629
5SV03F005T	R 2"	R 2"	318	458	313	311	691	829	658	98	547	629
5SV04F005T	R 2"	R 2"	318	458	313	311	691	829	658	98	572	629
5SV05F007T	R 2"	R 2"	318	458	313	311	691	829	658	98	639	629
5SV06F011T	R 2"	R 2"	318	458	313	311	691	829	658	98	664	629
5SV07F011T	R 2"	R 2"	318	458	313	311	691	829	658	98	689	629
5SV08F011T	R 2"	R 2"	318	458	313	311	691	829	658	98	714	629
5SV09F015T	R 2"	R 2"	318	458	313	311	691	829	658	98	749	629
5SV10F015T	R 2"	R 2"	318	458	313	311	691	829	658	98	774	629
5SV11F015T	R 2"	R 2"	318	458	313	311	691	829	658	98	799	629
5SV12F022T	R 2"	R 2"	318	458	313	311	691	829	658	98	859	629
5SV13F022T	R 2"	R 2"	318	458	313	311	691	829	658	98	884	629
5SV14F022T	R 2"	R 2"	318	458	313	311	691	829	658	98	909	629
5SV15F022T	R 2"	R 2"	318	458	313	311	691	829	658	98	934	629
5SV16F022T	R 2"	R 2"	318	458	313	311	691	829	658	98	959	629
5SV18F030T	R 2"	R 2"	318	458	313	311	691	829	682	109	1030	640
5SV21F030T	R 2"	R 2"	318	458	313	311	691	829	682	109	1105	640
10SV01F007T	R 2"1/2	R 2"1/2	367	497	345	356	788	929	682	114	654	640
10SV02F007T	R 2"1/2	R 2"1/2	367	497	345	356	788	929	682	114	654	640
10SV03F011T	R 2"1/2	R 2"1/2	367	497	345	356	788	929	682	114	686	640
10SV04F015T	R 2"1/2	R 2"1/2	367	497	345	356	788	929	682	114	728	640
10SV05F022T	R 2"1/2	R 2"1/2	367	497	345	356	788	929	682	114	795	640
10SV06F022T	R 2"1/2	R 2"1/2	367	497	345	356	788	929	682	114	827	640
10SV07F030T	R 2"1/2	R 2"1/2	367	497	345	356	788	929	682	114	869	640
10SV08F030T	R 2"1/2	R 2"1/2	367	497	345	356	788	929	682	114	901	640
10SV09F040T	R 2"1/2	R 2"1/2	367	497	345	356	788	929	682	114	954	640
10SV10F040T	R 2"1/2	R 2"1/2	367	497	345	356	788	929	682	114	986	640
10SV11F040T	R 2"1/2	R 2"1/2	367	497	345	356	788	929	682	114	1018	640

Dimensions in mm. Tolerance ± 10 mm.

gmd20ra_esv-f-en_a_td

GMD20

**TWO-PUMP BOOSTER SETS, GMD20 SERIES
VERTICAL ELECTRIC PUMPS WITH NON-RETURN VALVE
ON DELIVERY SIDE**

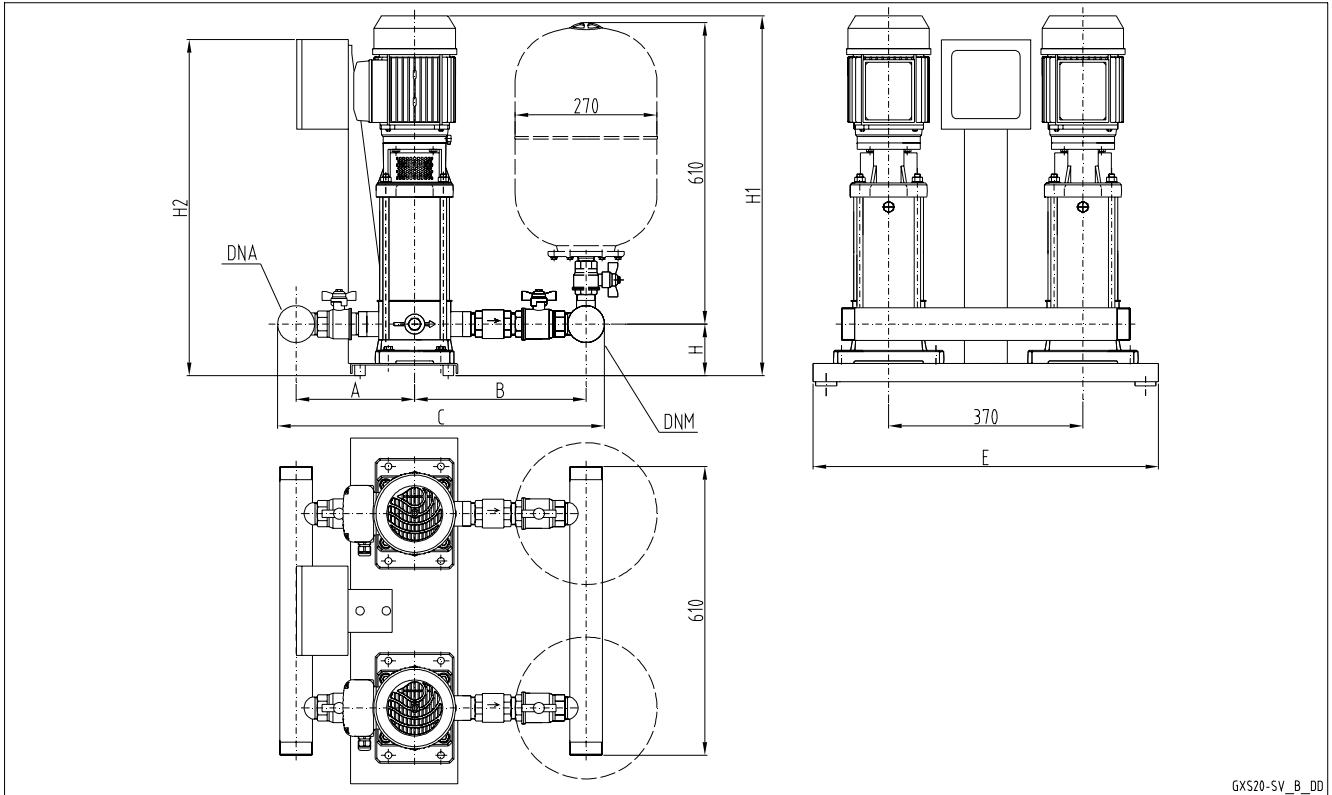

GXS20-SV_B_DD

GMD20

TWO-PUMP BOOSTER SETS, GMD20 SERIES VERTICAL ELECTRIC PUMPS WITH NON-RETURN VALVE ON DELIVERY SIDE

GMD 20	DNA	DNM	A		B		C		E	H	H1	H2
			STD/DW	AISI	STD/DW	AISI	STD/DW	AISI				
3SV02T003T	R 2"	R 2"	233	312	285	367	578	739	658	73	485	629
3SV03T003T	R 2"	R 2"	233	312	285	367	578	739	658	73	485	629
3SV04T003T	R 2"	R 2"	233	312	285	367	578	739	658	73	505	629
3SV05T005T	R 2"	R 2"	233	312	285	367	578	739	658	73	547	629
3SV06T005T	R 2"	R 2"	233	312	285	367	578	739	658	73	567	629
3SV07T007T	R 2"	R 2"	233	312	285	367	578	739	658	73	629	629
3SV08T007T	R 2"	R 2"	233	312	285	367	578	739	658	73	649	629
3SV09T011T	R 2"	R 2"	233	312	285	367	578	739	658	73	669	629
3SV10T011T	R 2"	R 2"	233	312	285	367	578	739	658	73	689	629
3SV11T011T	R 2"	R 2"	233	312	285	367	578	739	658	73	709	629
3SV12T011T	R 2"	R 2"	233	312	285	367	578	739	658	73	729	629
3SV13T015T	R 2"	R 2"	233	312	285	367	578	739	658	73	759	629
3SV14T015T	R 2"	R 2"	233	312	285	367	578	739	658	73	779	629
3SV16T015T	R 2"	R 2"	233	312	285	367	578	739	658	73	819	629
3SV19T022T	R 2"	R 2"	233	312	285	367	578	739	658	73	914	629
3SV21T022T	R 2"	R 2"	233	312	285	367	578	739	658	73	954	629
5SV02T003T	R 2"	R 2"	248	336	310	403	618	799	658	73	475	629
5SV03T005T	R 2"	R 2"	248	336	310	403	618	799	658	73	522	629
5SV04T005T	R 2"	R 2"	248	336	310	403	618	799	658	73	547	629
5SV05T007T	R 2"	R 2"	248	336	310	403	618	799	658	73	614	629
5SV06T011T	R 2"	R 2"	248	336	310	403	618	799	658	73	639	629
5SV07T011T	R 2"	R 2"	248	336	310	403	618	799	658	73	664	629
5SV08T011T	R 2"	R 2"	248	336	310	403	618	799	658	73	689	629
5SV09T015T	R 2"	R 2"	248	336	310	403	618	799	658	73	724	629
5SV10T015T	R 2"	R 2"	248	336	310	403	618	799	658	73	749	629
5SV11T015T	R 2"	R 2"	248	336	310	403	618	799	658	73	774	629
5SV12T022T	R 2"	R 2"	248	336	310	403	618	799	658	73	834	629
5SV13T022T	R 2"	R 2"	248	336	310	403	618	799	658	73	859	629
5SV14T022T	R 2"	R 2"	248	336	310	403	618	799	658	73	884	629
5SV15T022T	R 2"	R 2"	248	336	310	403	618	799	658	73	909	629
5SV16T022T	R 2"	R 2"	248	336	310	403	618	799	658	73	934	629
5SV18T030T	R 2"	R 2"	248	336	310	403	618	799	682	84	1005	640
5SV21T030T	R 2"	R 2"	248	336	310	403	618	799	682	84	1080	640
10SV01T007T	R 2"1/2	R 2"1/2	291	386	356	471	723	933	682	114	654	640
10SV02T007T	R 2"1/2	R 2"1/2	291	386	356	471	723	933	682	114	654	640
10SV03T011T	R 2"1/2	R 2"1/2	291	386	356	471	723	933	682	114	686	640
10SV04T015T	R 2"1/2	R 2"1/2	291	386	356	471	723	933	682	114	728	640
10SV05T022T	R 2"1/2	R 2"1/2	291	386	356	471	723	933	682	114	795	640
10SV06T022T	R 2"1/2	R 2"1/2	291	386	356	471	723	933	682	114	827	640
10SV07T030T	R 2"1/2	R 2"1/2	291	386	356	471	723	933	682	114	869	640
10SV08T030T	R 2"1/2	R 2"1/2	291	386	356	471	723	933	682	114	901	640
10SV09T040T	R 2"1/2	R 2"1/2	291	386	356	471	723	933	682	114	954	640
10SV10T040T	R 2"1/2	R 2"1/2	291	386	356	471	723	933	682	114	986	640
10SV11T040T	R 2"1/2	R 2"1/2	291	386	356	471	723	933	682	114	1018	640

Dimensions in mm. Tolerance ± 10 mm.

gmd20_esv-t-en_a_td

GMD20

**TWO-PUMP BOOSTER SETS, GMD20 RA SERIES
VERTICAL ELECTRIC PUMPS WITH NON-RETURN VALVE
ON SUCTION SIDE**

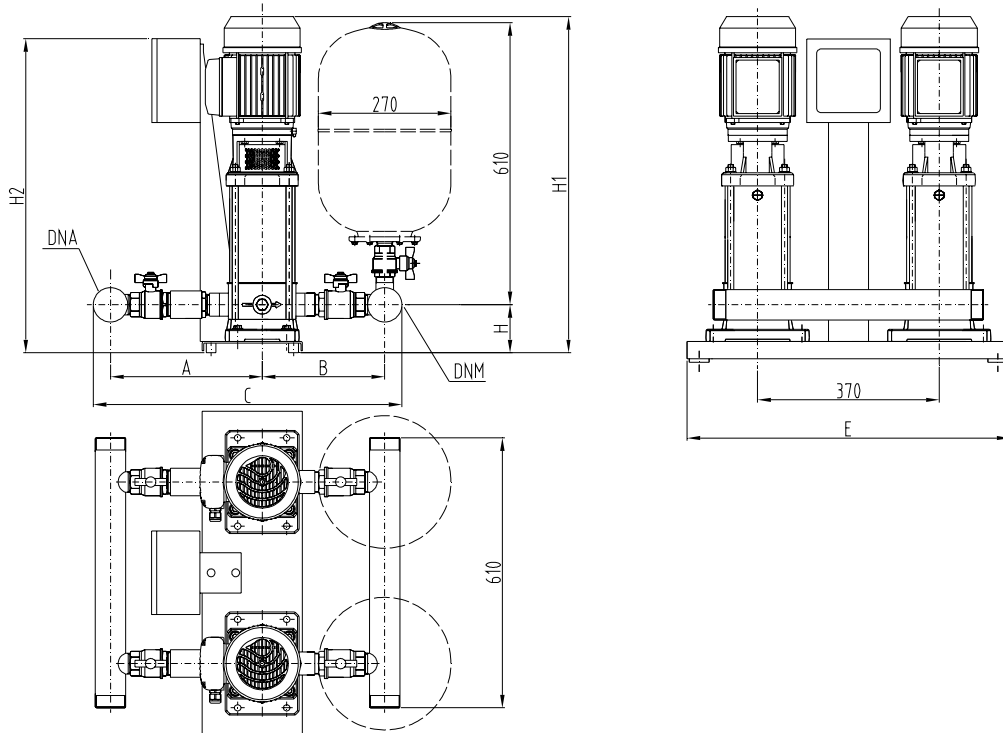

GXS20RA-SV_B_DD

GMD20

TWO-PUMP BOOSTER SETS, GMD20 RA SERIES VERTICAL ELECTRIC PUMPS WITH NON-RETURN VALVE ON SUCTION SIDE

GMD 20RA	DNA	DNM	A		B		C		E	H	H1	H2
			STD/DW	AISI	STD/DW	AISI	STD/DW	AISI				
3SV02T003T	R 2"	R 2"	285	367	268	312	613	739	658	73	485	629
3SV03T003T	R 2"	R 2"	285	367	268	312	613	739	658	73	485	629
3SV04T003T	R 2"	R 2"	285	367	268	312	613	739	658	73	505	629
3SV05T005T	R 2"	R 2"	285	367	268	312	613	739	658	73	547	629
3SV06T005T	R 2"	R 2"	285	367	268	312	613	739	658	73	567	629
3SV07T007T	R 2"	R 2"	285	367	268	312	613	739	658	73	629	629
3SV08T007T	R 2"	R 2"	285	367	268	312	613	739	658	73	649	629
3SV09T011T	R 2"	R 2"	285	367	268	312	613	739	658	73	669	629
3SV10T011T	R 2"	R 2"	285	367	268	312	613	739	658	73	689	629
3SV11T011T	R 2"	R 2"	285	367	268	312	613	739	658	73	709	629
3SV12T011T	R 2"	R 2"	285	367	268	312	613	739	658	73	729	629
3SV13T015T	R 2"	R 2"	285	367	268	312	613	739	658	73	759	629
3SV14T015T	R 2"	R 2"	285	367	268	312	613	739	658	73	779	629
3SV16T015T	R 2"	R 2"	285	367	268	312	613	739	658	73	819	629
3SV19T022T	R 2"	R 2"	285	367	268	312	613	739	658	73	914	629
3SV21T022T	R 2"	R 2"	285	367	268	312	613	739	658	73	954	629
5SV02T003T	R 2"	R 2"	310	403	296	336	666	799	658	73	475	629
5SV03T005T	R 2"	R 2"	310	403	296	336	666	799	658	73	522	629
5SV04T005T	R 2"	R 2"	310	403	296	336	666	799	658	73	547	629
5SV05T007T	R 2"	R 2"	310	403	296	336	666	799	658	73	614	629
5SV06T011T	R 2"	R 2"	310	403	296	336	666	799	658	73	639	629
5SV07T011T	R 2"	R 2"	310	403	296	336	666	799	658	73	664	629
5SV08T011T	R 2"	R 2"	310	403	296	336	666	799	658	73	689	629
5SV09T015T	R 2"	R 2"	310	403	296	336	666	799	658	73	724	629
5SV10T015T	R 2"	R 2"	310	403	296	336	666	799	658	73	749	629
5SV11T015T	R 2"	R 2"	310	403	296	336	666	799	658	73	774	629
5SV12T022T	R 2"	R 2"	310	403	296	336	666	799	658	73	834	629
5SV13T022T	R 2"	R 2"	310	403	296	336	666	799	658	73	859	629
5SV14T022T	R 2"	R 2"	310	403	296	336	666	799	658	73	884	629
5SV15T022T	R 2"	R 2"	310	403	296	336	666	799	658	73	909	629
5SV16T022T	R 2"	R 2"	310	403	296	336	666	799	658	73	934	629
5SV18T030T	R 2"	R 2"	310	403	296	336	666	799	682	84	1005	640
5SV21T030T	R 2"	R 2"	310	403	296	336	666	799	682	84	1080	640
10SV01T007T	R 2"1/2	R 2"1/2	356	471	339	386	771	933	682	114	654	640
10SV02T007T	R 2"1/2	R 2"1/2	356	471	339	386	771	933	682	114	654	640
10SV03T011T	R 2"1/2	R 2"1/2	356	471	339	386	771	933	682	114	686	640
10SV04T015T	R 2"1/2	R 2"1/2	356	471	339	386	771	933	682	114	728	640
10SV05T022T	R 2"1/2	R 2"1/2	356	471	339	386	771	933	682	114	795	640
10SV06T022T	R 2"1/2	R 2"1/2	356	471	339	386	771	933	682	114	827	640
10SV07T030T	R 2"1/2	R 2"1/2	356	471	339	386	771	933	682	114	869	640
10SV08T030T	R 2"1/2	R 2"1/2	356	471	339	386	771	933	682	114	901	640
10SV09T040T	R 2"1/2	R 2"1/2	356	471	339	386	771	933	682	114	954	640
10SV10T040T	R 2"1/2	R 2"1/2	356	471	339	386	771	933	682	114	986	640
10SV11T040T	R 2"1/2	R 2"1/2	356	471	339	386	771	933	682	114	1018	640

Dimensions in mm. Tolerance ± 10 mm.

gmd20ra_esv-t-en_a_td

GMD20

Booster sets

MARKET SECTORS

CIVIL, INDUSTRIAL

APPLICATIONS

- Water network supply in condominiums, offices, hotels, shopping centres, factories.
- Water supply to agricultural water networks (e.g. irrigation).

GTKS20 Series



GTKS20

SPECIFICATIONS

- **Flow rate** up to 52 m³/h.
- **Head** up to 90 m.
- Electrical panel supply voltage:
1 x 230V ± 10%.
- Frequency: 50 Hz.
- Protection class
electrical panel IP 55.
- Protection class
converter IP 55.
- Maximum electric pump
power 2 x 1,1 kW.
- **Motor start** with converter.
- Maximum temperature of pumped liquid:
from 0 to +80° C (for BG, CEA, CA, SV).
from 0 to +60° C (for HMT, HMZT).
- **Horizontal design pump:**
BG-CEA-CA-HMT-HMZT series.
Maximum operating pressure 8 bar.
- **Vertical design pump:**
SV..T series.
Maximum operating pressure 16 bar.

TWO-PUMP BOOSTER SETS, GTKS20 SERIES IDENTIFICATION CODE

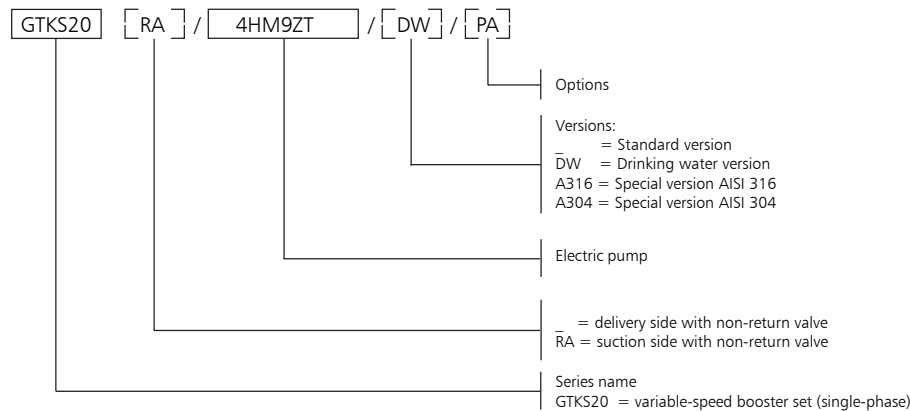

OPTIONS (ON DEMAND)

- 3A Booster set with electric pump certified 1A (Factory test reports issued by the end of assembly line; it includes QH curve).
- 3B Booster set with electric pump certified 1B (Test report issued by Audit Test Lab; it includes QH curve, efficiency and power).
- 60 Booster set with 60Hz supply voltage.
- BAP High pressure switch installed on the delivery manifold.
- C9 Delivery manifold at 90° with bend. The tanks can not be installed directly on the manifold.
- CM Suction or delivery manifold larger than standard size.
- CP Dry contact version: inverter in fault.
- IP65 IP65 version control panel.
- MA Pressure gauge installed on suction manifold.
- NL Dutch market version.
- PA Minimum pressure gauge installed on the suction manifold for dry-running protection.
- PQ Booster set with high suction pressure (pressure gauge/pressure switches/pressure transmitter increased of one range).
- RA Non return valves mounted on suction side (i.e. GTKS20RA/SV...).
- RE Heaters inside the control panel, with thermostat.
- SA No intake: no suction valves and suction manifold.
- SC Group with no control devices, such as pressure switches and transmitters; the pressure gauge is present.
- SCA No suction manifold (suction valves present).
- SCM Without delivery manifold (no pressure transmitters and pressure gauge, with delivery valves).
- SM Without delivery: without valves on delivery and without delivery manifold.
- TS Booster set with pumps equipped with special mechanical seals.
- UK UK market version.
- WM Wall-mounted electrical panel with fixing tabs. Cables L= 5m

AVAILABLE VERSIONS

- A304 Main component in contact with liquid in stainless steel Aisi 304 or superior; gasket, sealing tape and thread sealing are suitable for drinking water. Bolts and screws galvanized. Flanges not in contact with the liquid in galvanized steel.
- B304 Main component in contact with liquid in stainless steel Aisi 304 or superior; gasket, sealing tape and thread sealing are suitable for drinking water. Bolts and screws in Aisi 304 or superior. Flanges not in contact with the liquid in Aisi 304 or superior.
- C304 Main component in contact with liquid in stainless steel Aisi 304 or superior; gasket, sealing tape and thread sealing are suitable for drinking water. Baseplate, frame, supports, bolts and screws in Aisi 304 or superior. Flanges not in contact with the liquid in Aisi 304 or superior. Valves and their components completely in Aisi 304 or superior (body, disc, plate).
- A316 Main component in contact with liquid in stainless steel Aisi 316; gasket, sealing tape and thread sealing are suitable for drinking water. Pumps in Aisi 316 material. Bolts and screws galvanized. Flanges not in contact with the liquid in galvanized steel.
- B316 Main component in contact with liquid in stainless steel Aisi 316; gasket, sealing tape and thread sealing are suitable for drinkingwater. Pumps in Aisi 316 material. Bolts and screws in Aisi 316. Flanges not in contact with the liquid in Aisi 316.
- C316 Main component in contact with liquid in stainless steel Aisi 316; gasket, sealing tape and thread sealing are suitable for drinking water. Pumps in Aisi 316 material. Baseplate, frame, supports, bolts and screws in Aisi 316. Flanges not in contact with the liquid in Aisi 316. Valves and their components completely in Aisi 316 (body, disc, plate).
- DW Main component in contact with fluid suitable for drinking water or in stainless steel AISI 304 or superior quality.

TWO-PUMP BOOSTER SETS, GTKS20 SERIES OPERATING CHARACTERISTICS AND LIMITS

Liquids handled	Water containing no gas or corrosive and/or aggressive substances.
Fluid temperature	Depending on the type of pump: SV..T, CEA, CA: da oltre -10°C a + 80 °C. HMT, HMZT: da oltre -10°C a + 60 °C.
Ambient temperature	Above 0°C a + 40 °C.
Maximum operating pressure	Max 8 bar, 10 bar, 16 bar Depending on the type of pump.
Minimum inlet pressure	According to NPSH curve and losses, with a minimum margin of 0.5 m.
Maximum inlet pressure	The inlet pressure added to the pressure of the pump at zero flow must be lower than the maximum operating pressure of the set
Hourly starts (single pump)	Max 60 up to 3 kW, above 3 kW and up to 4 kW max 40.
Installation	Indoors, protected from the weather. Away from heat sources. Max elevation 1000 m ASL. Max humidity 50% without condensation.
Sound emission	Sound emission level Lp < 70 dB(A) for two-pump set with 2900 rpm motor with power up to 2 x 4 kW.

gts20-en_2p_a_ti

TABLE OF MATERIALS

NAME	MATERIAL			
	(STANDARD)	DW	A304	A316
Manifolds	AISI 304	AISI 304	AISI 304	AISI 316
On-off valves	Nickel-plated brass	Nickel-plated brass	AISI 316	AISI 316
Non-return valves	Brass	Brass	AISI 304	AISI 316
Pressure switches	Chrome plated zinc alloy	AISI 304	AISI 304	AISI 304
Pressure trasmitter	AISI 316	AISI 316	AISI 316	AISI 316
Caps/plugs/flanges	Galvanized steel	AISI 304	AISI 304	AISI 316
Bracket	Galvanized steel	Galvanized steel	Galvanized steel	Galvanized steel
Base	Galvanized steel	Galvanized steel	Galvanized steel	Galvanized steel
Pump Body	AISI 304	AISI 304	AISI 304	AISI 316(*)

* Not all models of electric pumps are available in AISI 316. Consult technical catalog of pump.

gts20_2p-en_a_tm

TWO-PUMP BOOSTER SETS, GTKS20 SERIES MAIN COMPONENTS

- **Main On-off valves** on suction and discharge side of each pump, ball type with threaded coupling.
- **Check valve** on discharge side of each pump, spring-loaded type, with threaded coupling. For applications with air-cushion surge tanks, they are mounted on the suction side and the set is equipped with a connector for G 1/2" threaded flexible air feeder pipe (serie GTKS20..RA).
- **Suction manifold** made of galvanized or AISI 304 stainless steel with threaded ends. Threaded coupling for water charging.
- **Delivery manifold** made of galvanized or AISI 304 stainless steel with threaded ends. Fitted with R1" threaded couplings with caps to allow connection of 24 or 20-litre diaphragm pressure vessels.
- **Pressure gauge and 2 control transmitters** located on the delivery side of the unit.
- **Various couplings** in nickel-plated brass, galvanized steel or stainless steel depending on
- **Mounting base**, for pumpset and panel mounting brackets in galvanized steel.
- **Electric control panel**, IP55 protection class.

STANDARD VERSIONS AVAILABLE

See table of materials.

STANDARD VERSION For general applications

Brass or nickel-plated brass valves, brass or galvanized steel couplings.

DW VERSION (GTKS20../DW)

For drinking water applications.

The main components in contact with the liquid are certified suitable for drinking water or are made of AISI 304 or higher grade of stainless steel.

AISI304 Version (GTKS20../A304), AISI 316 (GTKS20../A316)

For special applications

Manifolds, valves, non-return valves and main components with parts directly in contact with the pumped liquid are made of AISI 304 or AISI 316 stainless steel.

Accessories available on request:

- Devices **against dry running** in one of the following versions:
 - float switch, for positive suction head;
 - probe electrodes kit, for positive suction head;
 - minimum pressure switch, for positive suction head.
- **Surge tank** in the following versions:
 - Air-cushion surge tank with compressor and accessories for surge tank and compressor.
 - Diaphragm vessel as an alternative to the air-cushion tank.
- **Kit featuring** a 24 or 20-litre **diaphragm expansion vessel** with ball valve (one for each pump), in the following versions, depending on the maximum head of the pumps:
 - 24-litre 8 bar cylinder water vessel kit
 - 24-litre 10 bar cylinder water vessel kit
 - 24-litre 16 bar cylinder water vessel kit
 - 20-litre 25 bar cylinder water vessel kit
- **Alarm kit**;
- **Air feeder** for **RA** version.

SPECIAL VERSIONS AVAILABLE ON REQUEST

(Contact the Sales and technical Assistance Service)

- Support base in AISI 304, AISI 316 stainless steel.
- Units with stainless steel expansion vessels.
- Units with special valves.

TWO-PUMP BOOSTER SETS, GTKS20 SERIES CONTROL PANEL

Single-phase electrical power supply panel for protecting up to two three-phase electric pumps (3x230Vac), with Teknospeed frequency converter, made from polycarbonate, featuring a transparent door and protected to IP55.

Main characteristics:

- Automatic switch with overload protection for each converter.
- Standard supply voltage: 1x230Vac +/-10%, 50/60Hz.
- No-water protection system device alternatives:
float switch, minimum pressure switch, external contact. By using one optional module, to insert inside the board, electrode probes with sensitivity adjustment can be installed.
- A special version with "clean" potential-free contacts for signalling faults in each converter is available in request.



Electric panel

TEKNOSPEED FREQUENCY CONVERTER

Each pump is controlled via the Teknospeed frequency converter which modulates the speed of rotation in order to keep system pressure constant. It is supplied complete with power-on, pump running and fault LED's, and a remote booster relay for converter overload, no-water, overheating alarms.

A float switch or an ON/OFF device protecting against dry running can also be installed. A serial line for transmitting information between the two units in order to assure cycle exchange, simultaneous operation in case of maximum demand and service continuity in case one pump is disabled.

Visual indications:
Green led: power on
Yellow led: converter operating and operating mode.
Flashing: speed adjustment
Constant: pressure control. Converter in stand-by
Red led: alarm active



Converter

TWO-PUMP BOOSTER SETS, GTKS20 SERIES HORIZONTAL ELECTRIC PUMPS WITH NON-RETURN VALVE ON DELIVERY SIDE

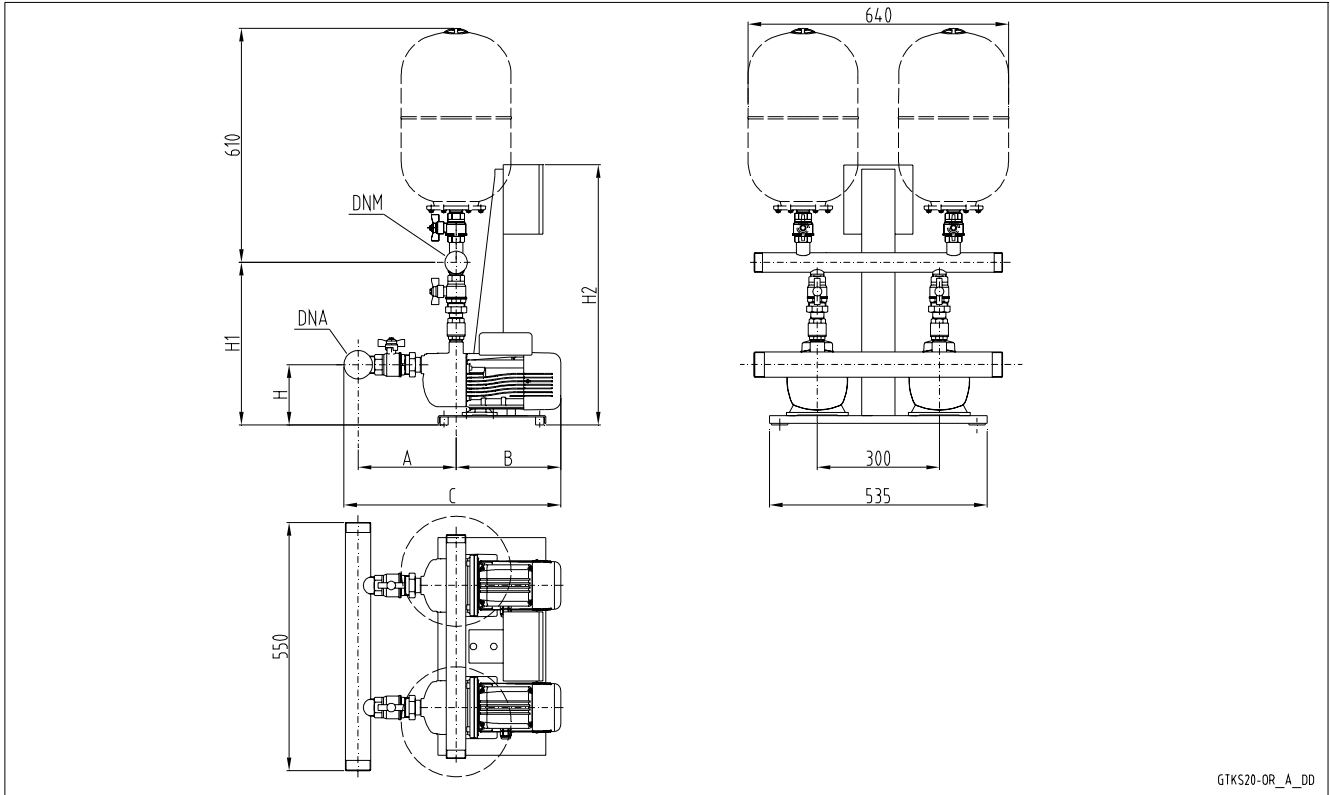

GTKS20

GTKS 20	DNA	DNM	A		B	C		H	H1		H2
			STD / DW	AISI		STD / DW	AISI		STD / DW	AISI	
BG3	R 2"	R 1 1/2"	214	299	297	541	626	189	423	501	640
BG5	R 2"	R 1 1/2"	214	299	311	555	640	189	423	501	640
BG7	R 2"	R 1 1/2"	214	299	356	600	685	189	423	501	640
BG9	R 2"	R 1 1/2"	214	299	356	600	685	189	423	501	640
BG11	R 2"	R 1 1/2"	214	299	356	600	685	189	423	501	640
2HM3ZT	R 2"	R 1 1/2"	241	326	249	520	605	149	382	460	640
2HM4ZT	R 2"	R 1 1/2"	266	351	249	545	630	149	382	460	640
2HM5ZT	R 2"	R 1 1/2"	291	376	249	570	655	149	382	460	640
2HM7ZT	R 2"	R 1 1/2"	316	401	308	654	739	141	374	452	640
4HM4ZT	R 2"	R 1 1/2"	241	326	249	520	605	149	382	460	640
4HM5ZT	R 2"	R 1 1/2"	266	351	249	545	630	149	382	460	640
4HM7ZT	R 2"	R 1 1/2"	291	376	308	629	714	141	374	452	640
4HM9ZT	R 2"	R 1 1/2"	316	401	308	654	739	141	374	452	640
CEA70/3	R 2"	R 1 1/2"	196	281	260	486	571	134	421	499	640
CEA70/5	R 2"	R 1 1/2"	196	281	274	500	585	134	421	499	640
CEA80/5	R 2"	R 1 1/2"	196	281	320	546	631	134	421	499	640
CEA120/3	R 2"	R 2"	196	281	274	500	585	134	476	505	640
CEA120/5	R 2"	R 2"	196	281	320	546	631	134	476	505	640
CEA210/2	R 2" 1/2	R 2 1/2"	207	318	331	576	687	134	460	602	640
CEA210/3	R 2" 1/2	R 2 1/2"	207	318	331	576	687	134	460	602	640
CEA370/1	R 2" 1/2	R 2 1/2"	207	318	331	576	687	134	460	602	640
CA70/33	R 2"	R 1 1/2"	276	361	289	595	680	128	435	513	640
CA70/34	R 2"	R 1 1/2"	276	361	289	595	680	128	435	513	640
CA70/45	R 2"	R 1 1/2"	276	361	289	595	680	128	435	513	640
CA120/33	R 2"	R 2"	276	361	289	595	680	128	490	519	640

gtps20_or-en_e_td

TWO-PUMP BOOSTER SETS, GTKS20 RA SERIES HORIZONTAL ELECTRIC PUMPS WITH NON-RETURN VALVE ON SUCTION SIDE

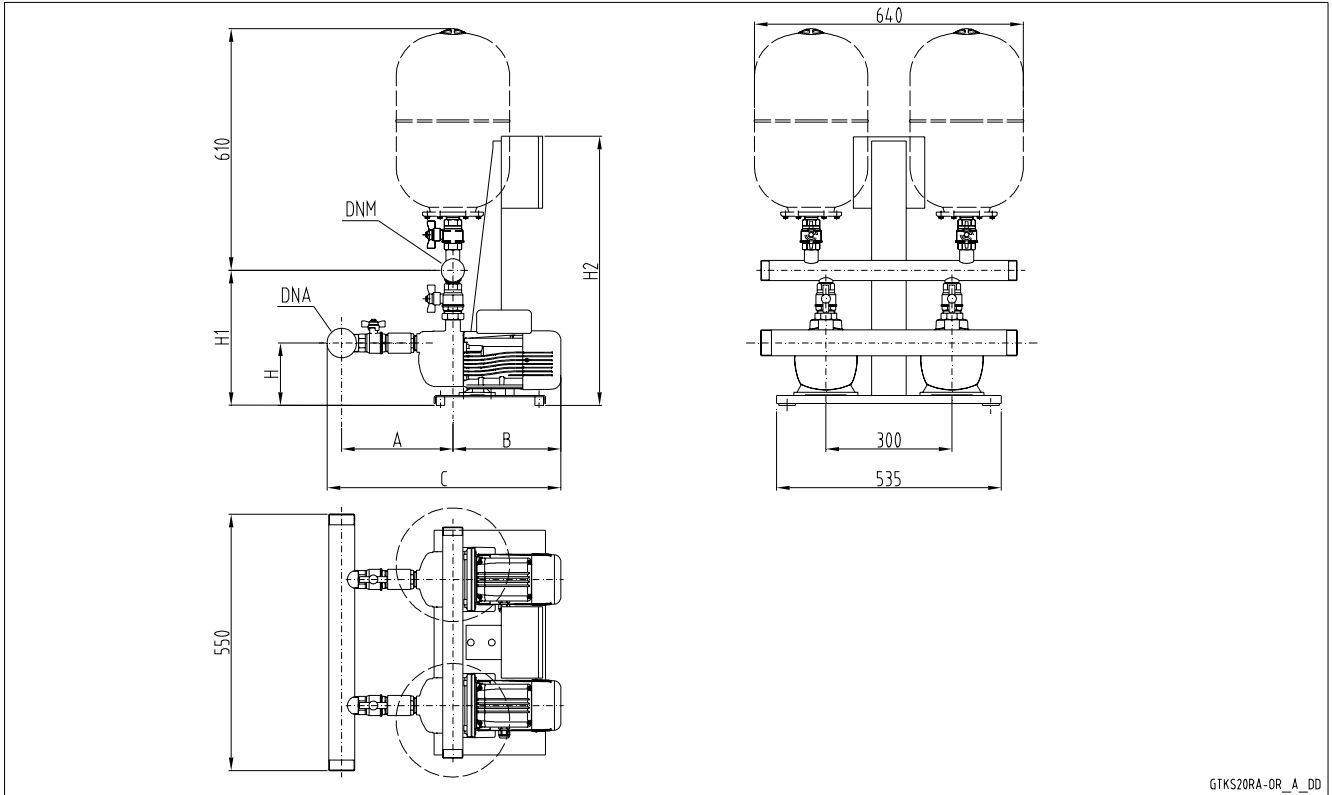

GTKS20RA-OR_A_DD

GTKS20

GTKS 20RA	DNA	DNM	A		B	C		H	H1		H2
			STD / DW	AISI		STD / DW	AISI		STD / DW	AISI	
BG3	R 2"	R 1 1/2"	267	429	297	653	815	189	371	454	640
BG5	R 2"	R 1 1/2"	267	429	311	653	815	189	371	454	640
BG7	R 2"	R 1 1/2"	267	429	356	653	815	189	371	454	640
BG9	R 2"	R 1 1/2"	267	429	356	653	815	189	371	454	640
BG11	R 2"	R 1 1/2"	267	429	356	653	815	189	371	454	640
2HM3ZT	R 2"	R 1 1/2"	294	456	249	573	735	149	330	413	640
2HM4ZT	R 2"	R 1 1/2"	319	481	249	598	760	149	330	413	640
2HM5ZT	R 2"	R 1 1/2"	344	506	249	623	785	149	330	413	640
2HM7ZT	R 2"	R 1 1/2"	369	531	308	707	869	141	322	405	640
4HM4ZT	R 2"	R 1 1/2"	294	456	249	573	735	149	330	413	640
4HM5ZT	R 2"	R 1 1/2"	319	481	249	598	760	149	330	413	640
4HM7ZT	R 2"	R 1 1/2"	344	506	308	682	844	141	322	405	640
4HM9ZT	R 2"	R 1 1/2"	369	531	308	707	869	141	322	405	640
CEA70/3	R 2"	R 1 1/2"	249	411	260	539	701	134	369	452	640
CEA70/5	R 2"	R 1 1/2"	249	411	274	553	715	134	369	452	640
CEA80/5	R 2"	R 1 1/2"	249	411	320	599	761	134	369	452	640
CEA120/3	R 2"	R 2"	249	411	274	553	715	134	375	458	640
CEA120/5	R 2"	R 2"	249	411	320	599	761	134	375	458	640
CEA210/2	R 2" 1/2	R 2 1/2"	287	422	331	656	791	134	398	483	640
CEA210/3	R 2" 1/2	R 2 1/2"	287	467	331	656	836	134	398	483	640
CEA370/1	R 2" 1/2	R 2 1/2"	287	467	331	656	836	134	398	483	640
CA70/33	R 2"	R 1 1/2"	329	491	289	648	810	128	383	466	640
CA70/34	R 2"	R 1 1/2"	329	491	289	648	810	128	383	466	640
CA70/45	R 2"	R 1 1/2"	329	491	289	648	810	128	383	466	640
CA120/33	R 2"	R 2"	329	491	289	648	810	128	389	472	640

gts20ra_or-en_e_td

TWO-PUMP BOOSTER SETS, GTKS20 SERIES VERTICAL ELECTRIC PUMPS WITH NON-RETURN VALVE ON DELIVERY SIDE

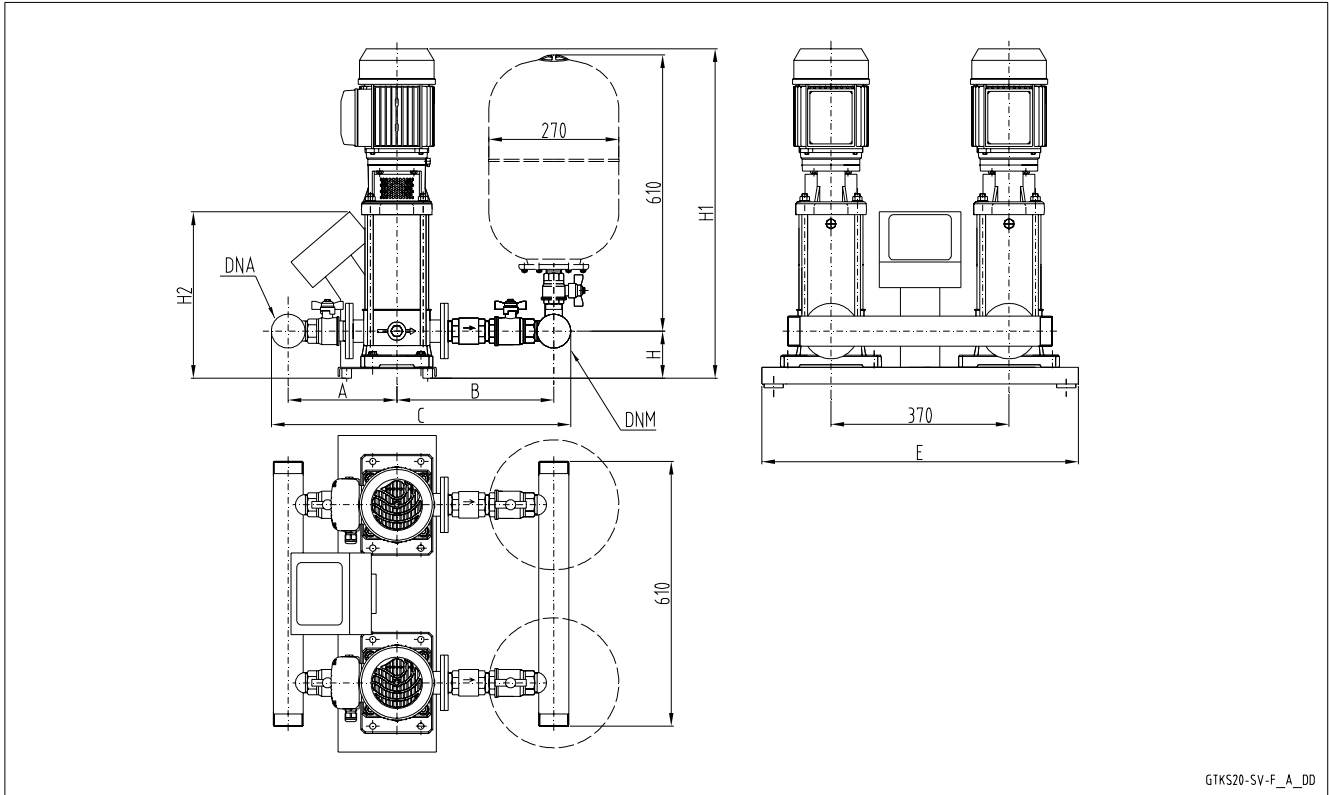

GTKS20-SV-F_A_DD

GTKS20

GTKS 20	DNA	DNM	A		B		C		E	H	H1	H2
			STD/DW	AISI	STD/DW	AISI	STD/DW	AISI				
3SV02F003T	R 2"	R 2"	252	301	304	346	616	707	658	98	510	629
3SV03F003T	R 2"	R 2"	252	301	304	346	616	707	658	98	510	629
3SV04F003T	R 2"	R 2"	252	301	304	346	616	707	658	98	530	629
3SV05F005T	R 2"	R 2"	252	301	304	346	616	707	658	98	572	629
3SV06F005T	R 2"	R 2"	252	301	304	346	616	707	658	98	592	629
3SV07F007T	R 2"	R 2"	252	301	304	346	616	707	658	98	654	629
3SV08F007T	R 2"	R 2"	252	301	304	346	616	707	658	98	674	629
3SV09F011T	R 2"	R 2"	252	301	304	346	616	707	658	98	694	629
3SV10F011T	R 2"	R 2"	252	301	304	346	616	707	658	98	714	629
3SV11F011T	R 2"	R 2"	252	301	304	346	616	707	658	98	734	629
3SV12F011T	R 2"	R 2"	252	301	304	346	616	707	658	98	754	629
5SV02F003T	R 2"	R 2"	265	311	327	431	652	802	658	98	500	629
5SV03F005T	R 2"	R 2"	265	311	327	431	652	802	658	98	547	629
5SV04F005T	R 2"	R 2"	265	311	327	431	652	802	658	98	572	629
5SV05F007T	R 2"	R 2"	265	311	327	431	652	802	658	98	639	629
5SV06F011T	R 2"	R 2"	265	311	327	431	652	802	658	98	664	629
5SV07F011T	R 2"	R 2"	265	311	327	431	652	802	658	98	689	629
5SV08F011T	R 2"	R 2"	265	311	327	431	652	802	658	98	714	629
10SV01F007T	R 2"1/2	R 2"1/2	297	356	362	497	735	929	682	114	654	640
10SV02F007T	R 2"1/2	R 2"1/2	297	356	362	497	735	929	682	114	654	640
10SV03F011T	R 2"1/2	R 2"1/2	297	356	362	497	735	929	682	114	686	640

Dimensions in mm. Tolerance ± 10 mm.

gths20_esv-f-en_a_td

TWO-PUMP BOOSTER SETS, GTKS20 RA SERIES VERTICAL ELECTRIC PUMPS WITH NON-RETURN VALVE ON SUCTION SIDE

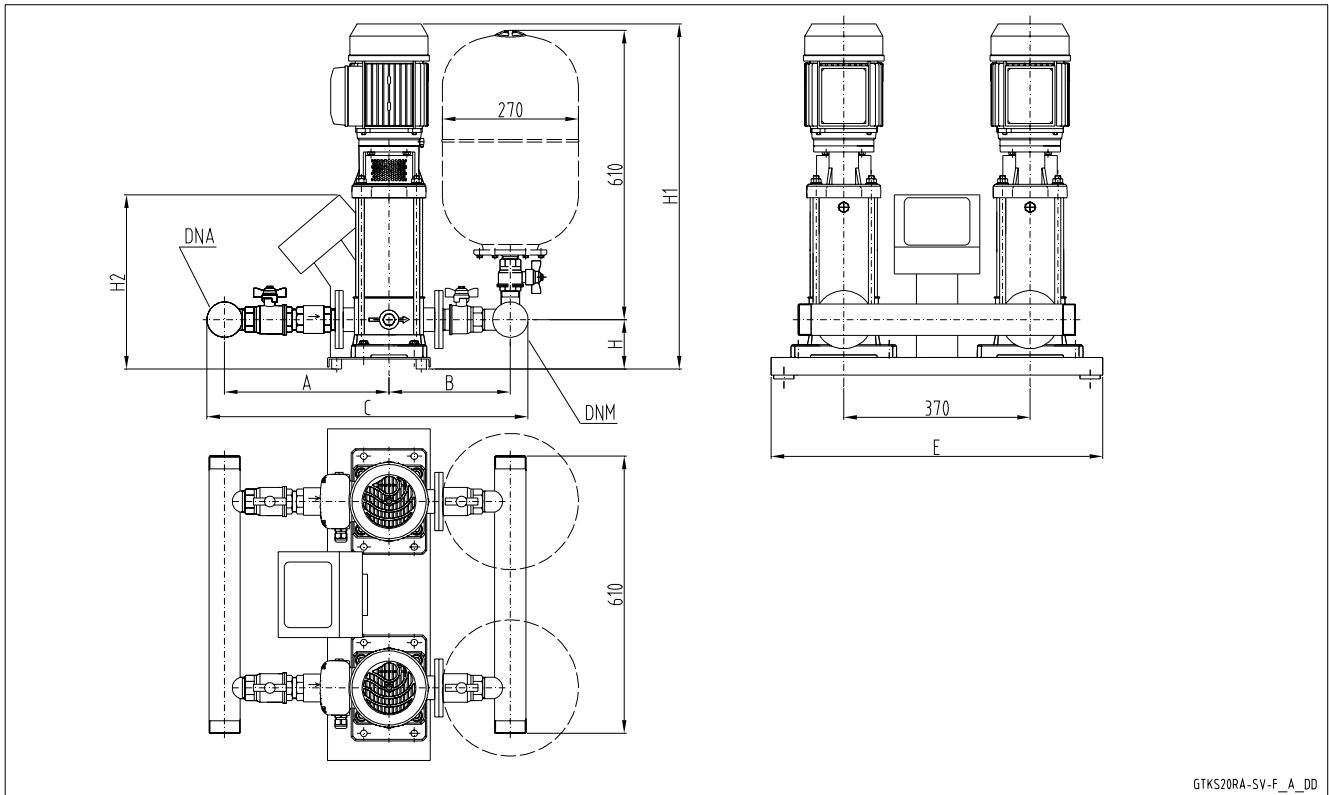

GTKS20RA-SV-F_A_DD

GTKS20

GTKS 20RA	DNA	DNM	A		B		C		E	H	H1	H2
			STD/DW	AISI	STD/DW	AISI	STD/DW	AISI				
3SV02F003T	R 2"	R 2"	297	350	287	301	644	711	658	98	510	629
3SV03F003T	R 2"	R 2"	297	350	287	301	644	711	658	98	510	629
3SV04F003T	R 2"	R 2"	297	372	287	301	644	733	658	98	530	629
3SV05F005T	R 2"	R 2"	297	372	287	301	644	733	658	98	572	629
3SV06F005T	R 2"	R 2"	297	372	287	301	644	733	658	98	592	629
3SV07F007T	R 2"	R 2"	297	372	287	301	644	733	658	98	654	629
3SV08F007T	R 2"	R 2"	297	372	287	301	644	733	658	98	674	629
3SV09F011T	R 2"	R 2"	297	372	287	301	644	733	658	98	694	629
3SV10F011T	R 2"	R 2"	297	372	287	301	644	733	658	98	714	629
3SV11F011T	R 2"	R 2"	297	372	287	301	644	733	658	98	734	629
3SV12F011T	R 2"	R 2"	297	372	287	301	644	733	658	98	754	629
5SV02F003T	R 2"	R 2"	318	431	313	311	691	802	658	98	500	629
5SV03F005T	R 2"	R 2"	318	431	313	311	691	802	658	98	547	629
5SV04F005T	R 2"	R 2"	318	431	313	311	691	802	658	98	572	629
5SV05F007T	R 2"	R 2"	318	431	313	311	691	802	658	98	639	629
5SV06F011T	R 2"	R 2"	318	431	313	311	691	802	658	98	664	629
5SV07F011T	R 2"	R 2"	318	431	313	311	691	802	658	98	689	629
5SV08F011T	R 2"	R 2"	318	431	313	311	691	802	658	98	714	629
10SV01F007T	R 2 1/2"	R 2 1/2"	367	497	345	356	788	929	682	114	654	640
10SV02F007T	R 2 1/2"	R 2 1/2"	367	497	345	356	788	929	682	114	654	640
10SV03F011T	R 2 1/2"	R 2 1/2"	367	497	345	356	788	929	682	114	686	640

Dimensions in mm. Tolerance ± 10 mm.

gths20ra_esv-f-en_a_td

TWO-PUMP BOOSTER SETS, GTKS20 SERIES VERTICAL ELECTRIC PUMPS WITH NON-RETURN VALVE ON DELIVERY SIDE

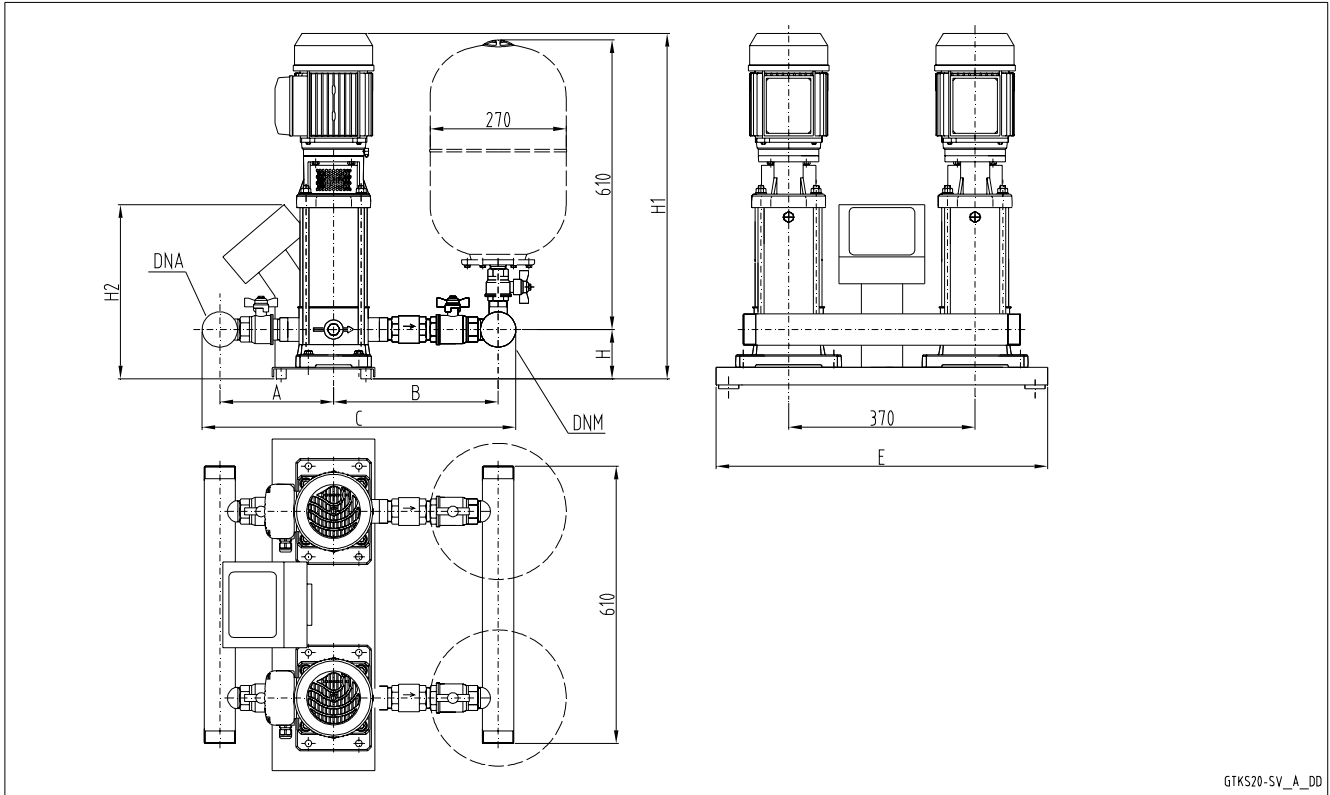

GTKS20-SV_A_DD

GTKS20

GTKS 20	DNA	DNM	A		B		C		E	H	H1	H2
			STD/DW	AISI	STD/DW	AISI	STD/DW	AISI				
3SV02T003T	R 2"	R 2"	233	312	285	367	578	739	658	73	485	629
3SV03T003T	R 2"	R 2"	233	312	285	367	578	739	658	73	485	629
3SV04T003T	R 2"	R 2"	233	312	285	367	578	739	658	73	505	629
3SV05T005T	R 2"	R 2"	233	312	285	367	578	739	658	73	547	629
3SV06T005T	R 2"	R 2"	233	312	285	367	578	739	658	73	567	629
3SV07T007T	R 2"	R 2"	233	312	285	367	578	739	658	73	629	629
3SV08T007T	R 2"	R 2"	233	312	285	367	578	739	658	73	649	629
3SV09T011T	R 2"	R 2"	233	312	285	367	578	739	658	73	669	629
3SV10T011T	R 2"	R 2"	233	312	285	367	578	739	658	73	689	629
3SV11T011T	R 2"	R 2"	233	312	285	367	578	739	658	73	709	629
3SV12T011T	R 2"	R 2"	233	312	285	367	578	739	658	73	729	629
5SV02T003T	R 2"	R 2"	248	336	310	403	618	799	658	73	475	629
5SV03T005T	R 2"	R 2"	248	336	310	403	618	799	658	73	522	629
5SV04T005T	R 2"	R 2"	248	336	310	403	618	799	658	73	547	629
5SV05T007T	R 2"	R 2"	248	336	310	403	618	799	658	73	614	629
5SV06T011T	R 2"	R 2"	248	336	310	403	618	799	658	73	639	629
5SV07T011T	R 2"	R 2"	248	336	310	403	618	799	658	73	664	629
5SV08T011T	R 2"	R 2"	248	336	310	403	618	799	658	73	689	629
10SV01T007T	R 2 1/2"	R 2 1/2"	291	386	356	471	723	933	682	114	654	640
10SV02T007T	R 2 1/2"	R 2 1/2"	291	386	356	471	723	933	682	114	654	640
10SV03T011T	R 2 1/2"	R 2 1/2"	291	386	356	471	723	933	682	114	686	640

Dimensions in mm. Tolerance ± 10 mm.

gths20_esv-t-en_a_td

TWO-PUMP BOOSTER SETS, GTKS20 RA SERIES VERTICAL ELECTRIC PUMPS WITH NON-RETURN VALVE ON SUCTION SIDE

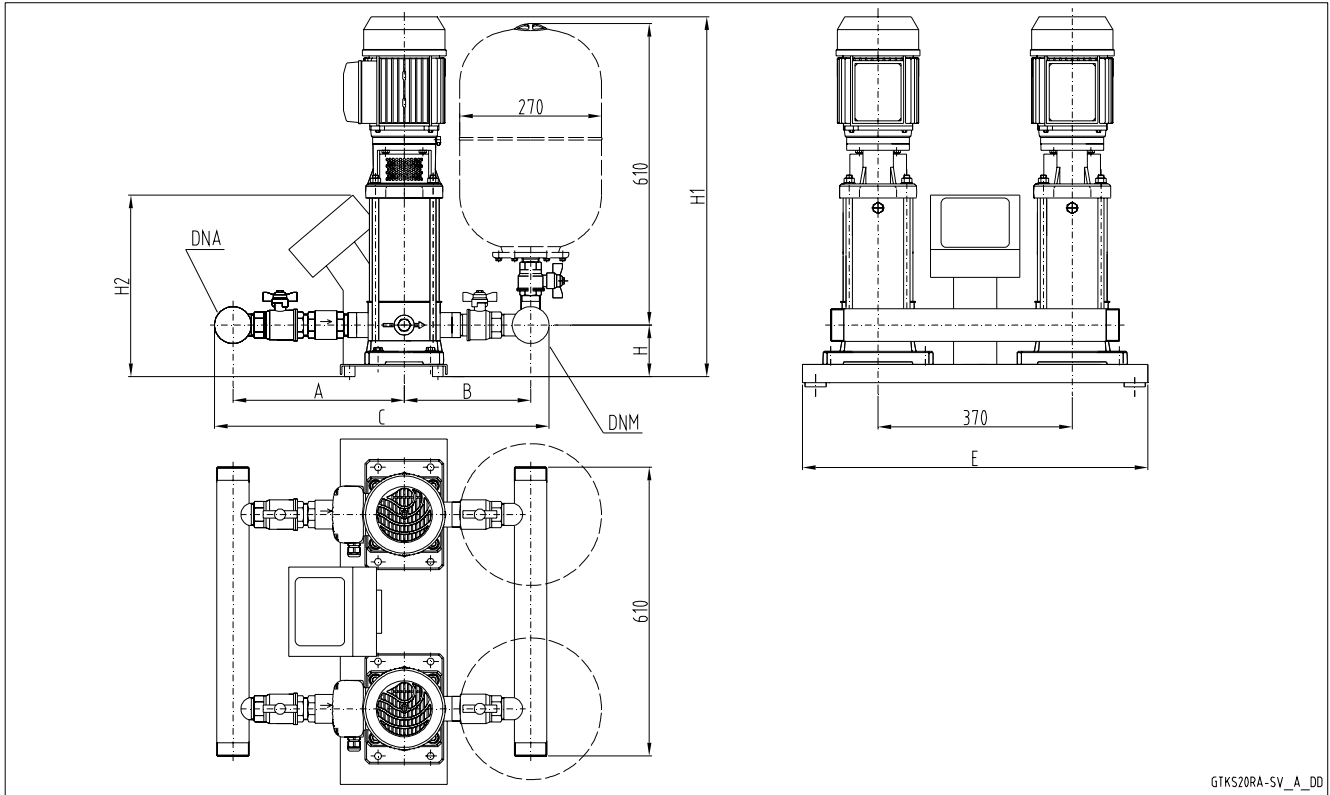

GTKS20RA-SV_A_DD

GTKS20

GTKS 20RA	DNA	DNM	A		B		C		E	H	H1	H2
			STD/DW	AISI	STD/DW	AISI	STD/DW	AISI				
3SV02T003T	R 2"	R 2"	285	367	268	312	613	739	658	73	485	629
3SV03T003T	R 2"	R 2"	285	367	268	312	613	739	658	73	485	629
3SV04T003T	R 2"	R 2"	285	367	268	312	613	739	658	73	505	629
3SV05T005T	R 2"	R 2"	285	367	268	312	613	739	658	73	547	629
3SV06T005T	R 2"	R 2"	285	367	268	312	613	739	658	73	567	629
3SV07T007T	R 2"	R 2"	285	367	268	312	613	739	658	73	629	629
3SV08T007T	R 2"	R 2"	285	367	268	312	613	739	658	73	649	629
3SV09T011T	R 2"	R 2"	285	367	268	312	613	739	658	73	669	629
3SV10T011T	R 2"	R 2"	285	367	268	312	613	739	658	73	689	629
3SV11T011T	R 2"	R 2"	285	367	268	312	613	739	658	73	709	629
3SV12T011T	R 2"	R 2"	285	367	268	312	613	739	658	73	729	629
5SV02T003T	R 2"	R 2"	310	403	296	336	666	799	658	73	475	629
5SV03T005T	R 2"	R 2"	310	403	296	336	666	799	658	73	522	629
5SV04T005T	R 2"	R 2"	310	403	296	336	666	799	658	73	547	629
5SV05T007T	R 2"	R 2"	310	403	296	336	666	799	658	73	614	629
5SV06T011T	R 2"	R 2"	310	403	296	336	666	799	658	73	639	629
5SV07T011T	R 2"	R 2"	310	403	296	336	666	799	658	73	664	629
5SV08T011T	R 2"	R 2"	310	403	296	336	666	799	658	73	689	629
10SV01T007T	R 2"1/2	R 2"1/2	356	471	339	386	771	933	682	114	654	640
10SV02T007T	R 2"1/2	R 2"1/2	356	471	339	386	771	933	682	114	654	640
10SV03T011T	R 2"1/2	R 2"1/2	356	471	339	386	771	933	682	114	686	640

Dimensions in mm. Tolerance ± 10 mm.

gths20ra_esv-t-en_a_td

Booster sets

MARKET SECTORS
CIVIL, INDUSTRIAL

APPLICATIONS

- Water network supply in condominiums, offices, hotels, shopping centres, factories.
- Water supply to agricultural water networks (e.g. irrigation).

GHV20 Series

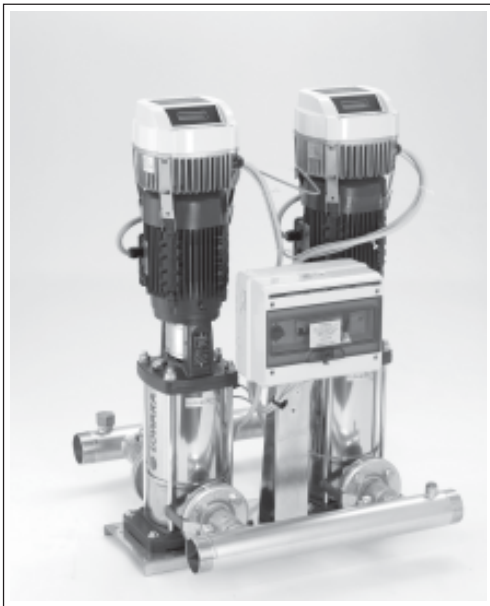

SPECIFICATIONS

- **Flow rate** up to 58 m³/h.
- **Head** up to 160 m.
- Electrical panel supply voltage: 1 x 230V ± 10% for power up to 2,2 kW.
- Electrical panel supply voltage: 3 x 400V ± 10% for power from 1,1 kW to 4 kW.
- Protection class electrical panel IP 55.
- Protection class converter IP 55.
- Maximum electric pump power 2 x 4 kW.
- Frequency: 50 Hz.
- **Motor start** with converter.
- Maximum temperature of pumped liquid: from -10 to +80° C.
- **Vertical design pump:** SV..T series. Maximum operating pressure 16 bar.

TWO-PUMP BOOSTER SETS, GHV20 SERIES IDENTIFICATION CODE

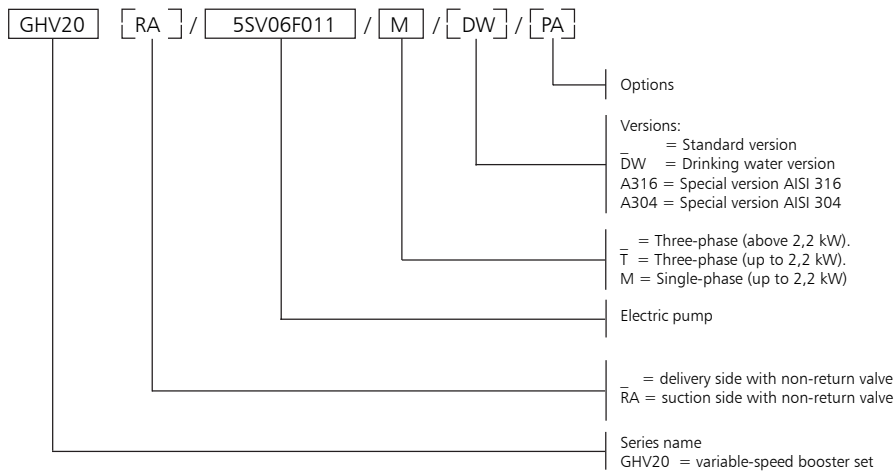

OPTIONS (ON DEMAND)

- 2S Hydrovar® equipped with double sensor.
- 3A Booster set with electric pump certified 1A (Factory test reports issued by the end of assembly line; it includes QH curve).
- 3B Booster set with electric pump certified 1B (Test report issued by Audit Test Lab; it includes QH curve, efficiency and power).
- 60 Booster set with 60Hz supply voltage.
- BAP High pressure switch installed on the delivery manifold.
- BF Hydrovar® equipped with "B" filter for for three-phase supply; domestic environment.
- C9 Delivery manifold at 90° with bend. The expansion vessels cannot be installed directly on the manifold.
- CM Suction or delivery manifold larger than standard size.
- CP Clean contacts version: converter faulty, start/stop for each pump.
- HFD Hydrovar® and panel mounted delivery side (for wall mounted version Hydrovar®), available only up to 22kw power. Beyond this size, the control panel will be wall mounted WM and the Hydrovar® will be wall mounted HWM.
- HFS Hydrovar® and panel mounted suction side (for wall mounted version hydrovar).
- HWM Wall mounted hydrovar , cables lenght = 5 m.
- IP65 IP65 version control panel.
- KV Kit voltmeter.
- MA Pressure gauge installed on suction manifold.
- NL Dutch market version.
- PA Minimum pressure gauge installed on the suction manifold for dry-running protection.
- PQ Booster set with higt suction pressure (pressure gauge/pressure switches/pressure transmitter increased of one range).
- RA Non return valves mounted on suction side (Es. GHV20RA/SV...).
- RE Heaters inside the control panel, with thermostat.
- SA No intake: no suction valves and suction manifold.
- SC Group with no control devices, such as pressure switches and transmitters; the pressure gauge is present.
- SCA No suction manifold (suction valves present).
- SCM Without delivery manifold (no pressure transmitters and pressure gauge, with delivery valves).
- SM Without delivery: without valves on delivery and without delivery manifold.
- TS Booster set with pumps equipped with special mechanical seals.
- UK UK market version.
- VA Electric control panel fitted with analogue voltmeter and ammeter.
- WM Wall-mounted electrical panel with fixing tabs. Cables L= 5m

AVAILABLE VERSIONS

- A304 Main component in contact with liquid in stainless steel Aisi 304 or superior; gasket, sealing tape and thread sealing are suitable for drinking water. Bolts and screws galvanized. Flanges not in contact with the liquid in galvanized steel.
- B304 Main component in contact with liquid in stainless steel Aisi 304 or superior; gasket, sealing tape and thread sealing are suitable for drinking water. Bolts and screws in Aisi 304 or superior. Flanges not in contact with the liquid in Aisi 304 or superior.
- C304 Main component in contact with liquid in stainless steel Aisi 304 or superior; gasket, sealing tape and thread sealing are suitable for drinking water. Baseplate, frame, supports, bolts and screws in Aisi 304 or superior. Flanges not in contact with the liquid in Aisi 304 or superior. Valves and their components completely in Aisi 304 or superior (body, disc, plate).
- A316 Main component in contact with liquid in stainless steel Aisi 316; gasket, sealing tape and thread sealing are suitable for drinking water. Pumps in Aisi 316 material. Bolts and screws galvanized. Flanges not in contact with the liquid in galvanized steel.
- B316 Main component in contact with liquid in stainless steel Aisi 316; gasket, sealing tape and thread sealing are suitable for drinkingwater. Pumps in Aisi 316 material. Bolts and screws in Aisi 316. Flanges not in contact with the liquid in Aisi 316.
- C316 Main component in contact with liquid in stainless steel Aisi 316; gasket, sealing tape and thread sealing are suitable for drinking water. Pumps in Aisi 316 material. Baseplate, frame, supports, bolts and screws in Aisi 316. Flanges not in contact with the liquid in Aisi 316. Valves and their components completely in Aisi 316 (body, disc, plate).
- DW Main component in contact with fluid suitable for drinking water or in stainless steel AISI 304 or superior quality.

TWO-PUMP BOOSTER SETS, GHV20 SERIES OPERATING CHARACTERISTICS AND LIMITS

Liquids handled	Water containing no gas or corrosive and/or aggressive substances.
Fluid temperature	Depending on the type of pump: SV..T: da oltre -10°C a + 80 °C.
Ambient temperature	Above 0°C a + 40 °C.
Maximum operating pressure	Max 8 bar, 10 bar, 16 bar Depending on the type of pump.
Minimum inlet pressure	According to NPSH curve and losses, with a minimum margin of 0.5 m.
Maximum inlet pressure	The inlet pressure added to the pressure of the pump at zero flow must be lower than the maximum operating pressure of the set
Hourly starts (single pump)	Max 60 up to 3 kW, above 3 kW and up to 4 kW max 40.
Installation	Indoors, protected from the weather. Away from heat sources. Max elevation 1000 m ASL. Max humidity 50% without condensation.
Sound emission	Sound emission level Lp < 70 dB(A) for two-pump set with 2900 rpm motor with power up to 2 x 4 kW.

ghv20-en_2p_a_ti

TABLE OF MATERIALS FOR SETS WITH 3-5-10SV PUMPS UP TO 4kW

NAME	MATERIAL			
	(STANDARD)	DW	A304	A316
Manifolds	AISI 304	AISI 304	AISI 304	AISI 316
On-off valves	Nickel-plated brass	Nickel-plated brass	AISI 316	AISI 316
Non-return valves	Brass	Brass	AISI 304	AISI 316
Pressure switches	Chrome plated zinc alloy	AISI 304	AISI 304	AISI 304
Pressure transmitters	AISI 316	AISI 316	AISI 316	AISI 316
Caps/plugs/flanges	Galvanized steel	AISI 304	AISI 304	AISI 316
Bracket	Galvanized steel	Galvanized steel	Galvanized steel	Galvanized steel
Base	Galvanized steel	Galvanized steel	Galvanized steel	Galvanized steel
Pump body	AISI 304	AISI 304	AISI 304	AISI 316
Outer sleeve	AISI 304	AISI 304	AISI 304	AISI 316

gfixvsv_2p-en_d_tm

TABLE OF MATERIALS FOR SETS WITH 15-22SV PUMPS

DENOMINATION	MATERIAL			
	(STANDARD)	DW	A304	A316
Manifolds	AISI304	AISI 304	AISI 304	AISI 316
On-off valves	Nickel-plated brass	Nickel-plated brass	AISI 316	AISI 316
Non-return valves	Painted cast iron with stainless steel flaps	Painted cast iron with stainless steel flaps	AISI 304	AISI 316
Pressure switches	Chrome plated zinc alloy	AISI 304	AISI 304	AISI 304
Pressure transmitters	AISI 316	AISI 316	AISI 316	AISI 316
Caps/plugs/flanges	Galvanized steel	AISI 304	AISI 304	AISI 316
Bracket	Painted steel (*)	Painted steel (*)	Painted steel (*)	Painted steel (*)
Base	Painted steel	Painted steel	Painted steel	Painted steel
Pump body	AISI 304	AISI 304	AISI 304	AISI 316
Outer sleeve	AISI 304	AISI 304	AISI 304	AISI 316

(*) of galvanized steel for two-pump sets up to 4kW

gfixvsv16_2p-en_b_tm

TWO-PUMP BOOSTER SETS, GHV20 SERIES MAIN COMPONENTS

- **Main On-off valves** on suction and discharge side of each pump, ball type with threaded coupling up to 2" size included. Butterfly type for installation between the flanges are used for larger diameters.
- **Check valve** on discharge side of each pump, spring-loaded type, with threaded coupling up to 1"1/2 size, as well as the double-swing type to fit between the flanges.
For applications with air-cushion surge tanks, they are mounted on the suction side and the set is equipped with a connector for G 1/2" threaded flexible air feeder pipe (serie GHV20..RA).
- **Suction manifold** made of galvanized or AISI 304 stainless steel with threaded or flanged ends depending on the type of pump (see drawings). Threaded coupling for water charging.
- **Delivery manifold** made of galvanized or AISI 304 stainless steel depending on the version, with threaded or flanged ends depending on the type of pump (see drawings). Fitted with two R1" threaded couplings with caps to allow connection of 24 or 20-litre diaphragm pressure vessels.
- **Pressure gauge and 2 control transmitters** located on the delivery side of the unit.
- **Various couplings** in nickel-plated brass, galvanized steel or stainless steel depending on the version.
- **Mounting base**, for pumpset and panel mounting brackets:
 - in galvanized steel for sets with electric pumps 3-5-10SV series up to 4 kW;
 - in painted steel for sets with electric pumps 15-22SV series.
- **Electric control panel**, IP55 protection class.

STANDARD VERSIONS AVAILABLE

See table of materials.

STANDARD VERSION

For general applications

Sets with 3-5-10SV pumps:

Nickel-plated brass valves, non return valves with brass or technical plastic discs.

Sets with 15-22SV pumps:

Nickel-plated brass valves, non-return valves with stainless steel flaps.

DW VERSION (GHV20../DW)

For drinking water applications.

The main components in contact with the liquid are certified suitable for drinking water or are made of AISI 304 or higher grade of stainless steel.

Sets with 3-5-10SV pumps:

Nickel-plated brass valves, non return valves with brass or technical plastic discs.

Sets with 15-22SV pumps:

Nickel-plated brass valves, non-return valves with stainless steel flaps.

AISI304 Version (GHV20../A304),

AISI 316 (GHV20../A316)

For special applications

Manifolds, valves, non-return valves and main components with parts directly in contact with the pumped liquid are made of AISI 304 or AISI 316 stainless steel.

Accessories available on request:

- Devices **against dry running** in one of the following versions:
 - float switch, for positive suction head;
 - probe electrodes kit, for positive suction head;
 - minimum pressure switch, for positive suction head.
- **Surge tank** in the following versions:
 - Air-cushion surge tank with compressor and accessories for surge tank and compressor.
 - Diaphragm vessel as an alternative to the air-cushion tank.
- **Kit featuring** a 24 or 20-litre **diaphragm expansion vessel** with ball valve (one for each pump), in the following versions, depending on the maximum head of the pumps:
 - 24-litre 8 bar cylinder water vessel kit
 - 24-litre 10 bar cylinder water vessel kit
 - 24-litre 16 bar cylinder water vessel kit
 - 20-litre 25 bar cylinder water vessel kit
- **Alarm kit;**
- **Air feeder** for RA version.

SPECIAL VERSIONS AVAILABLE ON REQUEST

(Contact the Sales and technical Assistance Service)

- Support base in AISI 304, AISI 316 stainless steel.
- Units with stainless steel expansion vessels.
- Units with special valves.
- Sets with 5 electric pumps.
- Sets with 6 electric pumps.
- Sets with jockey pump.

TWO-PUMP BOOSTER SETS, GHV20 SERIES VARIABLE-SPEED PUMP SYSTEMS

AVAILABLE SERIES

- GHV Multi-Master series. One Hydrovar® Master-type frequency converter for each electric pump.
- GHV Master + Basic series. One Hydrovar® frequency converter for each electric pump. Hydrovar® Master and/or Basic type.
- GHC GHC Cascade control series. Single Hydrovar® Master type frequency converter per set; the other electric pumps run at fixed speed, without a converter.

From a mechanical standpoint, the **Module concept** related to **HYDROVAR®** is divided in two parts, the **motor assembly** power unit (power unit) and the **control board**. In the basic configuration, that is with a single motor assembly, HYDROVAR® may be used as **“Basic Unit (BASIC)”** without having to use a control board. In this configuration HYDROVAR® may be used as a sequential pump in a multi-pump system with at least one master inverter.

By expanding the “Basic inverter” with the additional control board and the LCD screen, the HYDROVAR® **“Master Unit”** becomes suitable to operate in different modes and may be expanded by implementing several modules.

GHV VERSION, MASTER + BASIC SERIES

This mode provides several different combinations of different HYDROVAR® versions.

In general, each pump is equipped with a HYDROVAR® unit. Each pump in the system (which may count up to 8 pumps), is fitted with a HYDROVAR® unit (at least one as **“Master unit”** and the others as **“Basic units”**, to guarantee adequate system control); the units are connected one another by means of a serial interface.

Minimum requirements: one “Master unit” and the others equipped with “Basic unit”.

The entire control process takes always place by means of the “Master unit”, though it is also possible to alternate the standby pump sequence in order to distribute wear and allow for the same number of operating hours of the pumps controlled by basic inverters.

Following versions are available:

- **Power size from 1,5kW to 11 kW, motor mounted.**

General description of booster name:

GHV [][]: First digit: total number of pump, Second digit: number of Basic units.

Example:

- **GHV21**: two pumps booster set, one “Master Inverter” and one “Basic Inverter” configuration.
- **GHV31**: three pumps booster set, two “Master Inverter” and one “Basic Inverter” configuration.
- **GHV32**: three pumps booster set, one “Master Inverter” and two “Basic Inverter” configuration.

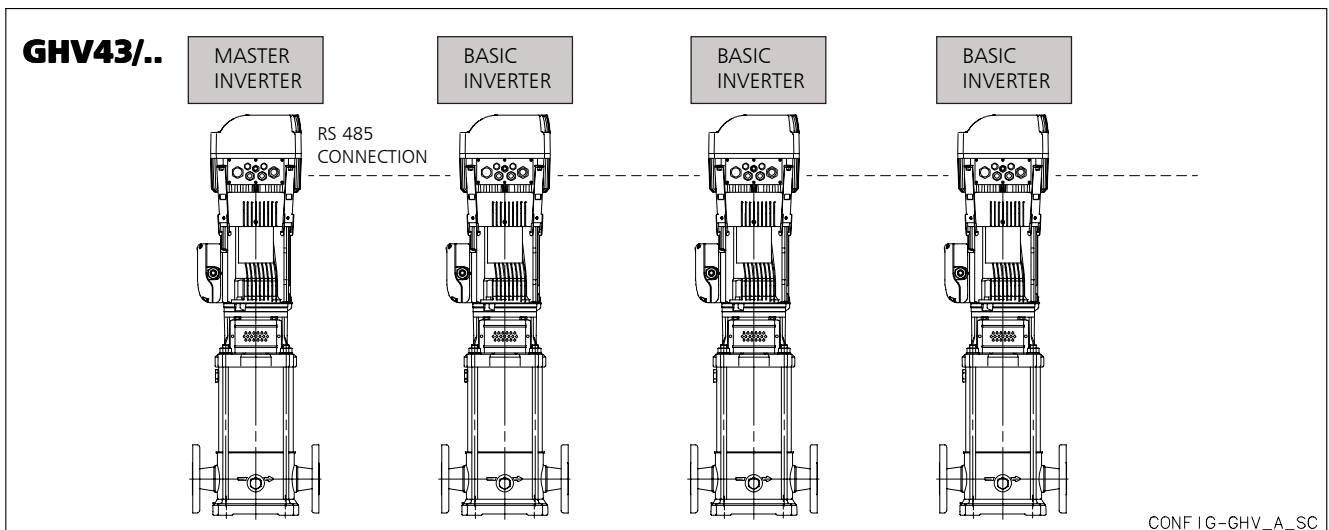

TWO-PUMP BOOSTER SETS, GHV20 SERIES MULTI MASTER SERIES

Each electric pump is fitted with a HYDROVAR® type “Master Unit”. Automatic alternation of the electric pumps is guaranteed in order to distribute wear and optimize the operating hours. The following power levels are available:

- Power from 1,5kW to 22 kW, motor assembly (maximum 8 units).

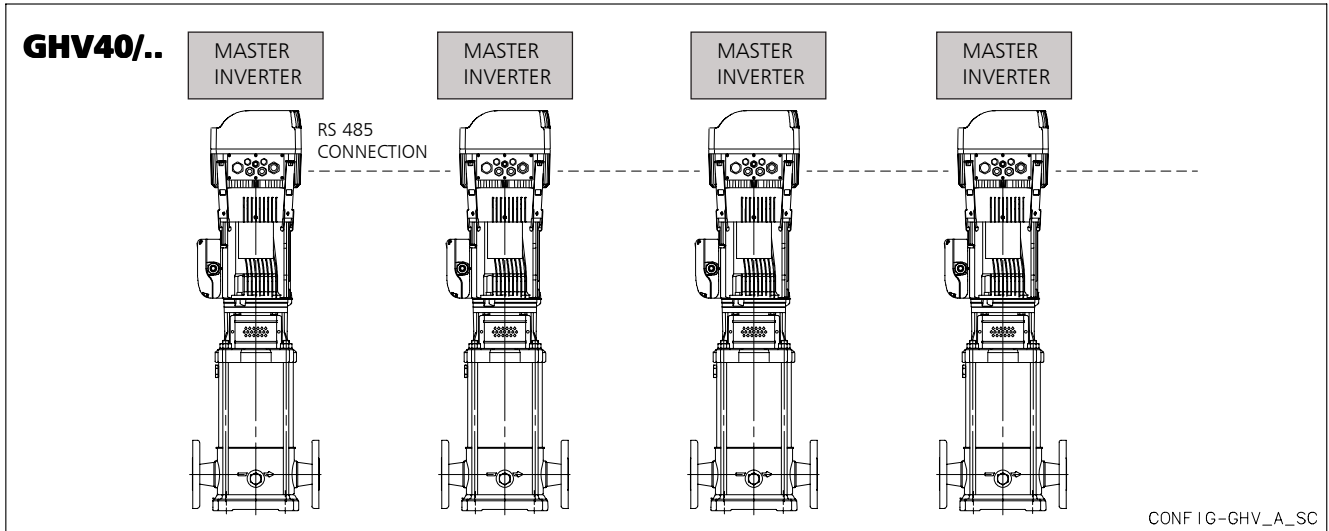

GHC VERSION, CASCADE CONTROL SERIES

One pump is equipped with a HYDROVAR® “Master unit”, while up to five fixed-speed pumps may be operated on request with the ON and OFF signal.

For this purpose an additional 5-relay board is fitted on to the “Master unit”. It is necessary to resort to an external electric panel, in that the HYDROVAR® relays are not capable of directly commutating the pumps, since they are used exclusively as signal terminals.

In this operating mode it is also possible to automatically alternate the fixed-speed pumps in order to distribute wear and allow the pumps to operate for the same number of hours. The inverter always feeds the same electric pump.

The following power levels are available:

- Power from 1,5kW to 22 kW, motor assembly (maximum 6 electric pumps)

Example:

- **GHC20**: pressure booster assembly made up of two pumps, a “Master inverter” and an electric pump running at fixed speed.
- **GHC30**: pressure booster assembly made up of three pumps, a “Master inverter” and two electric pumps running at fixed speed.

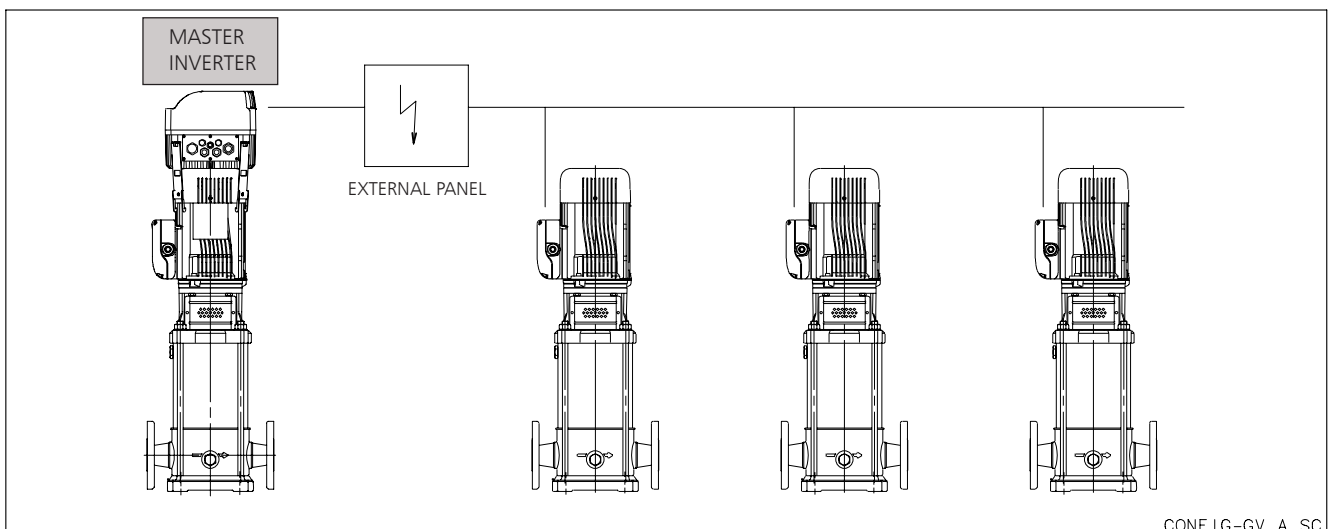

MAIN CHARACTERISTICS OF FREQUENCY CONVERTERS USED IN THE BOOSTER SETS GHV, GHC SERIES

The GHV, GHC series booster sets use a **Hydrovar®** frequency converter, an automatic device that adjusts the speed of the electric pump in order to maintain **constant pressure** in the system.

Converters with power up to 22 kW can be **mounted directly on to the motor**. Models up to 22 kW can be mounted alternatively on the wall if equipped with the optional **fan kit**. Models with over 22 kW power, up to 45 kW, are designed for wall mounting only. The pressure is measured by a **pressure transmitter** which uses a standard **4..20 mA** signal. The system pressure value can be read on the converter's display. A simple user interface allows you to set the desired pressure value for optimal adjustment, as well as to **view the operating data**, such as the hours of operation and any alarms triggered.

Included diagnostic menu to view temperature, current and voltage values of Hydrovar® facilitates diagnostics and failure analysis.

Indicator lights signal power status, pump running and malfunctions.

A **password** is required to access sensitive settings that allow you to **configure the converter** in order to adapt it to any control requirements, such as **flow resistance compensation, external control**, periodic testing and so on.

When more than one pump is used, the converters exchange information with each other through an **RS485 serial line** which can connect up to 8 Hydrovar® devices plus one external unit for remote control. Up to 4 Hydrovar® for power ratings from 30 to 45kW. The Pump-link and Pump-watcher dedicated systems, connected to Hydrovar®, allow remote control with a mobile or landline telephone system.

RS485 serial interface available as standard up to 22 kW, which allows to control the Hydrovar® converters from a Modbus® field serial bus line.

The converter is equipped with two **potential-free relays** which can be used for **remote signalling** of pump running and malfunction status, plus a programmable voltage **analogue output** for signalling the frequency or pressure.

Standard version with two sensors inputs for implementing of two actual values signals within one system (min/max, difference) or for a second sensor for safety reasons.

Specific digital **inputs** are used for protection against **water failure, motor overtemperature**, as well as for external enable signal and remote control.

The converter also incorporates a dry running protection function via an adjustable **minimum pressure** threshold.



Hydrovar® HV2.015 - HV4.110



Hydrovar® Wall mounted version

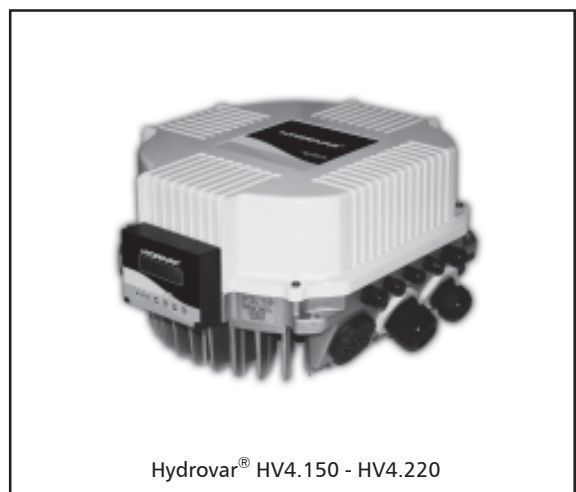

Hydrovar® HV4.150 - HV4.220

Class A filter standard for Hydrovar® three-phase power supply. E.g. Industrial areas, technical areas of any building fed from a dedicated transformer are examples of environment locations.

Class B filter standard for Hydrovar® single-phase power supply. E.g. Houses, apartments, commercial premises or offices in a residential building are examples of environment locations.

Further information are available into Hydrovar® manual.

TWO-PUMP BOOSTER SETS, GHV20 SERIES SPECIFICATIONS

Converter				Motor	
Model *	Power supply (V)	IP Class	Install.	Power supply (V)	Power (kW)
HV 2.015	1x230	IP 55	Motor	3x230	0,75-1,5
HV 2.022	1x230	IP 55	Motor	3x230	2,2
HV 4.022	3x400	IP 55	Motor	3x400	1,1-2,2
HV 4.030	3x400	IP 55	Motor	3x400	3
HV 4.040	3x400	IP 55	Motor	3x400	4
HV 4.055	3x400	IP 55	Motor	3x400	5,5
HV 4.075	3x400	IP 55	Motor	3x400	7,5
HV 4.110	3x400	IP 55	Motor	3x400	11
HV 4.150	3x400	IP 55	Motor	3x400	15
HV 4.185	3x400	IP 55	Motor	3x400	18,5
HV 4.220	3x400	IP 55	Motor	3x400	22
(HV 3.30)	3x400	IP 54	Wall	3x400	30
(HV 3.37)	3x400	IP 54	Wall	3x400	37
(HV 3.45)	3x400	IP 54	Wall	3x400	45

* The Hydrovar Modular is available single-phase up to 2,2kW and above 2,2kW up to 22kW three-phase power supply only.

gcom_hv-2p-en_d_te

CONTROL PANELS

Single-phase (GHV../M) or three-phase (GHV../T) electrical power supply panel for protecting up to two three-phase electric pumps (3x230Vac or 3x400Vac), with Hydrovar® frequency converter, made from polycarbonate, featuring a transparent door and protected to IP55 for power ratings up to 4kW. A metal case protected to IP55 is available on request.

Main characteristics:

- Automatic switch with overload protection for each Hydrovar® frequency converter.
- Standard supply voltage: 1x230Vac (GHV../M) or 3x400Vac (GHV../T) +/-10%, 50/60Hz.
- No-water protection system alternatives: float, minimum pressure switch, external contact or electrode probes via the electronic module with sensitivity adjustment.
- A special version with "clean" potential-free contacts for signalling: pump running, converter faulty. Configured for enable from external contact.

A Hydrovar® frequency converter, integrated to the motor of each pump, which controls the number of revs required to keep pressure constant and complete with: power-on, pump running and fault indicator LED's, control buttons. Complete with two relays for remote pump running and alarm signalling.

A serial line for transmitting information between the two units in order to assure cycle exchange, simultaneous operation in case of maximum demand and service continuity in case one of the two converters develops a fault. The standard external serial line can be used to connect a control system.



Control panel 2 pumps single-phase up to 2,2kW, or three-phase power supply up to 4kW



Control panel 2 pumps three-phase power supply with dry contacts up to 4kW

ENERGY SAVING

The worldwide demand for energy is growing all the time and, while the demand is increasing, production is coming up against serious problems of an environmental nature and related to the supply of raw materials. In other words, energy is an asset that is becoming more precious every day, imposing choices to optimise consumption, especially with a view to safeguarding the environment.

A very important improvement role is played by new technologies which include, among the most desirable parameters, environmental protection and energy saving as well as best technical performance. Drives for electric motors fall into this category. As well as making a considerable contribution to the decrease in energy consumption and consequently to the improvement of the environment, in many applications they also produce a notable reduction in the overall costs of running the installations.

Drives for Electric Motors

The electronic drives that are most involved in the general improvement of the quality of systems and installations, are those for asynchronous alternating current motors, generally three-phase induction motors. They may be divided into two large categories:

- Drives with variable voltage
- Drives with variable frequency

The first, called "starters" or "soft starters", are appliances that operate at constant frequency (that of the power mains), dose the voltage supplied to the load and have limited current.

The following figure illustrates the typical operation of the "soft starter":

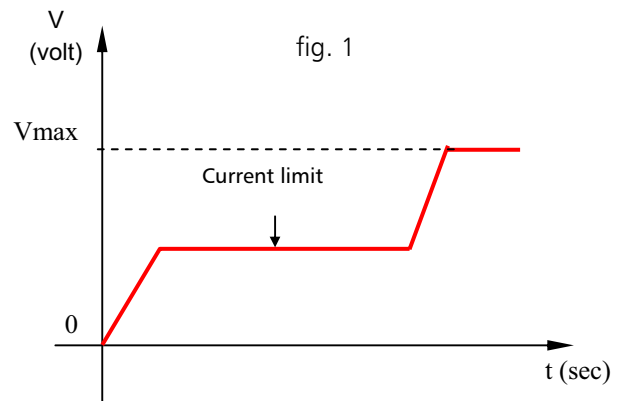

The second, called "Inverters" or "frequency converters" are most important from the point of view of energy saving and are able to supply the motor with a practically sinusoidal current (PMW) at a frequency that may vary from a value of practically 0 Hz to a rated frequency and beyond, with a constant flow (torque) or constant power. Typical example, fig.2:

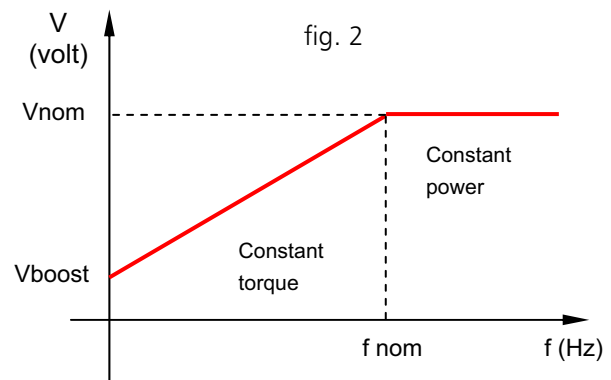

The applicatory advantages of the two categories of drives will be described below.

Softstart

The direct starting of an asynchronous motor presents considerable difficulties due to the peak current in the start phase. Typically the value of the starting current is about 7/8 times the rated current of the motor.

Direct start systems are therefore not generally convenient (except for small power); mainly because of the need to increase the size of the power supply mains (switches, fuses, etc. ...), and also problems of a mechanical nature, due to high stress in the start phase which in the medium/long term may prove to be destructive.

The electrical engineering industry has already found various practical solutions to the problems; the main ones are noted below:

- Special motors with double winding
- Starting with autotransformer
- Star/delta starting

These starting systems are certainly an improvement on direct starting, but they do not solve the problem. The advent of electronic starters ("soft starters") made a decisive contribution to solving the question.

ENERGY SAVING

This type of drive is able to supply performance advantages:

- Progressive start with a voltage ramp having a duration adjustable within wide time limits.
- Limited current start with a value that can be set from 100% to 500% of the rated value.
- Descending voltage ramp having a duration adjustable within wide time limits.
- Voltage ramps at starting and stopping adaptable to particular operations (pumps).
- Low-speed operation, with reversible running direction, for specific applications.
- "Energy Saving" function with automatic reduction of the voltage/current in the case of a prolonged underload.
- Safety devices that can be calibrated to prevent overheating of the motor, over/under currents and over/under voltages.
- Safety devices that can be calibrated to prevent prolonged or too frequent starts.
- Possibility of by-pass operation after starting, keeping all the safety devices active.

All these features make the electronic starter the ideal tool for solving the problems we have mentioned. With the recently designed starters, with both analog and digital control, it is possible to obtain considerable softer and more efficient starts than any other electromechanical system was able to achieve. Moreover, thanks to the intrinsic control and protection systems of the starter, it is generally possible to eliminate other protection equipment that would otherwise be necessary in the system.

In conclusion, in many applications, one can SAVE on:

- Structure and auxiliary equipment of the power supply system.
- Protection of the mechanical system against excessive stress.

Speed Adjustment

The speed adjustment systems allow energy consumption in proportion to the use of the system based on user demand. This allows considerable savings in systems working on a daily basis (24h).

Alongside applications that require operation of the electric motors at a constant speed, with steady voltage and frequency, there are many in which the electric motor must be able to vary its speed of rotation (frequency); moreover, in many applications the process control obtained by varying the speed (adjustment of flow rate, pressure, etc...) is much more convenient than any other method of adjustment.

For these applications the most suitable drives are certainly frequency converters, referred to below as "Inverters", which can supply the motor with the desired torque from a few rpm up to the rated speed beyond which they are still able to operate at constant power with a decreasing torque. The advantage of using the Inverter lies in the greater efficiency of the performance that it is able to give in comparison with electromechanical controls.

A useful application of frequency converters may simply be that of obtaining a soft start for a load that is particularly heavy to start (pump) and variable over time (flow rate). In any case the advantage of a soft start is present in all inverter-controlled systems for starting a motor, even in cases where speed adjustment is not needed.

The advantage is due to the fact that the inverter is able to supply the rated torque (with possibility of 150% overload with respect to the rated current), right from frequency zero. This is possible because the voltage to the motor, generated by the inverter, is in phase with the number of revolutions right from the start (unless the motor is running). In this way the losses in the motor are considerably reduced.

The starting torque that can be obtained using the inverter is greater than that obtained with a soft starter, and the demand for current in the whole starting phase is much lower.

The yearly saving, for a lost power of 40000 Kwh, with electromechanical start, may be as much as 2000 Euro.

The reliability and efficiency of the pump speed control systems means optimising consumption and processes as well as savings. In the specific case of pumping appliances, the immediate consequence of the use of these systems is the realisation of pumps with greater operative flexibility, with much larger and optimal performance curves. There are many advantages – above all, a pump that always works, irrespective of variations in the installation, in optimal conditions with less wear and less malfunctions. So there are less problems from downtime and the pumps require less frequent maintenance. Moreover, an installation where the pumps are controlled by an inverter is more efficient and less subject to stress:

- absence of water hammer (which occurs when switching off pumps driven in a traditional way);
- lower working pressures than systems with an autoclave or piezometric tank;
- pressure and flow rate conditions always adequate for the demands, because the inverter is able to adjust the pump gradually in real time according to the pressure trend in the installation.

ENERGY SAVING

All this results in less stress on all the components in the distribution network, and therefore in less maintenance of the network, greater reliability of supply and lower running costs.

In short, using a pumping system with one or more variable-speed pumps means:

- ✓ Saving energy;
- ✓ Optimising resources and processes;
- ✓ Having the possibility of complete integration of the management, control and supervision systems;
- ✓ Prolonging the life of the installations;
- ✓ Reducing maintenance costs;

Increasing the productivity and efficiency of an installation.

Comparison of starting systems

Having examined the various starting systems that can be realised for electric motors, direct start, star/delta, soft starter and inverter, they can be compared, analysing the absorbed currents and therefore the energy consumed (current = energy = kWh = MONEY)

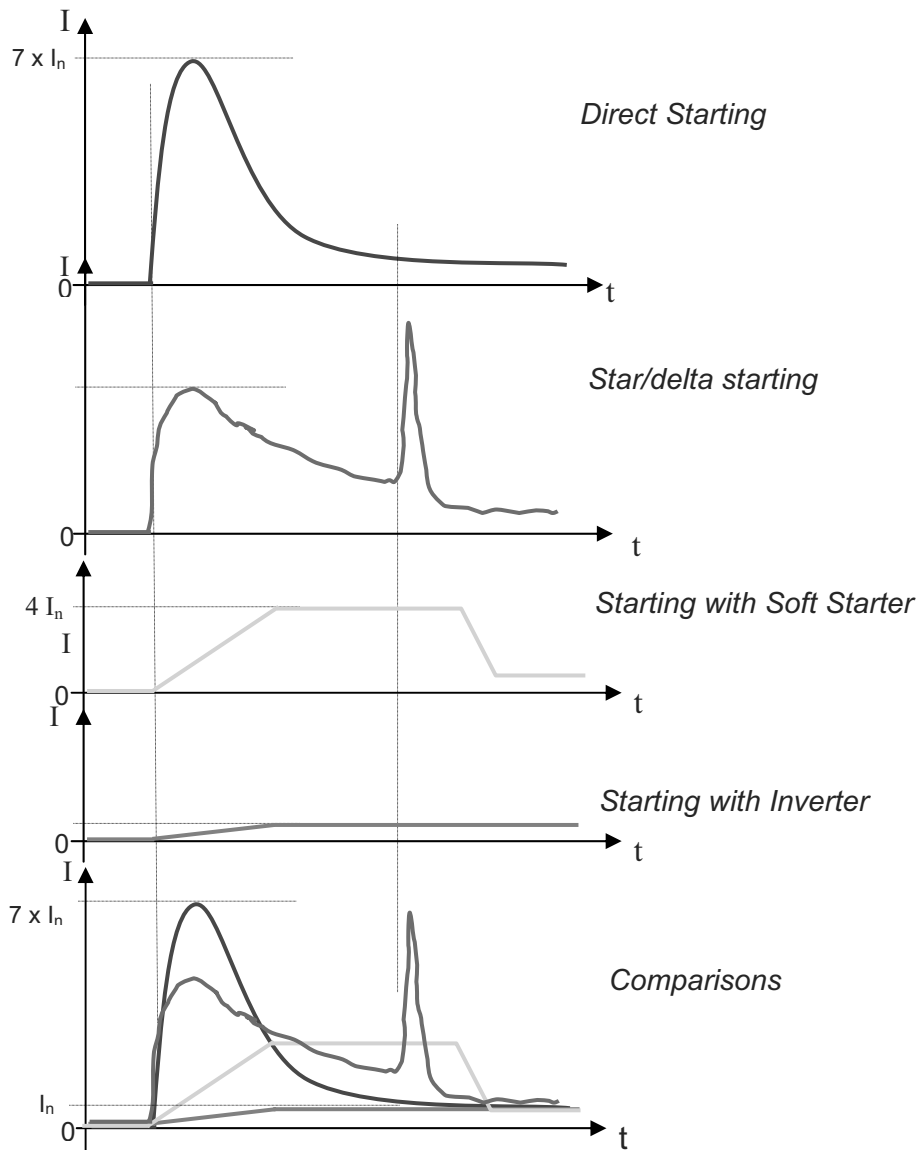

**TWO-PUMP BOOSTER SETS, GHV20 SERIES
EXAMPLE OF SPECIAL SETS
HYDROVAR MOUNTED ON A BRACKET SUCTION SIDE**

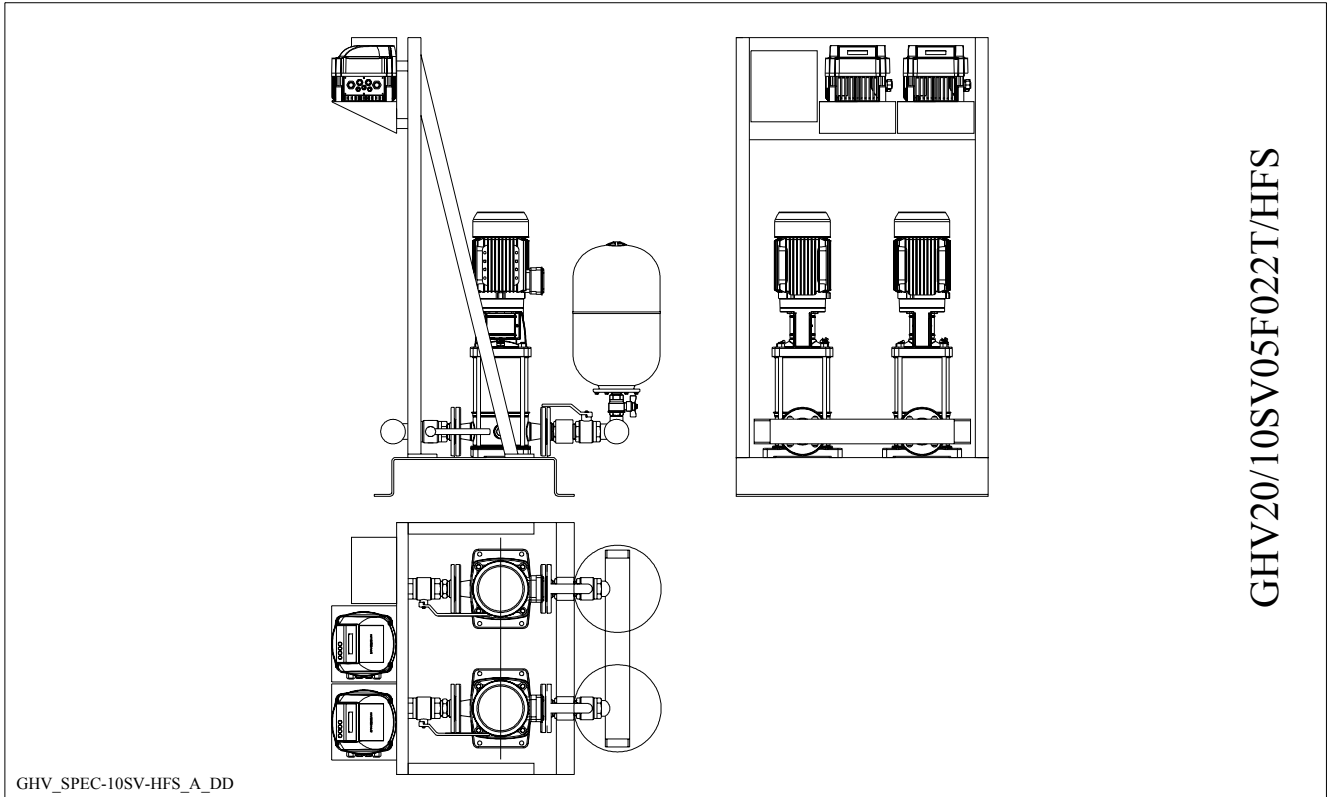

DELIVERY SIDE

GHV20

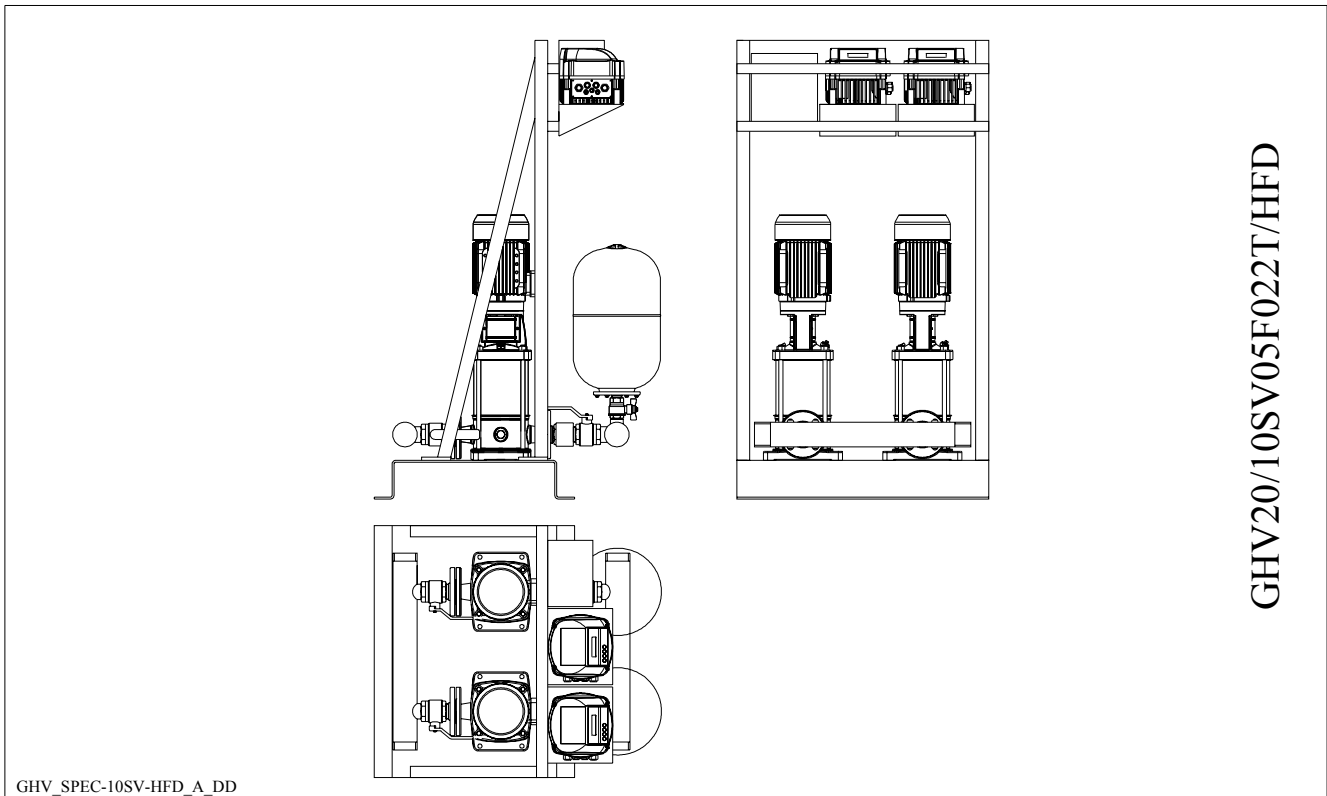

**BOOSTER SETS, GHV SERIES
SPECIAL VERSIONS WITH 5/6 PUMPS**

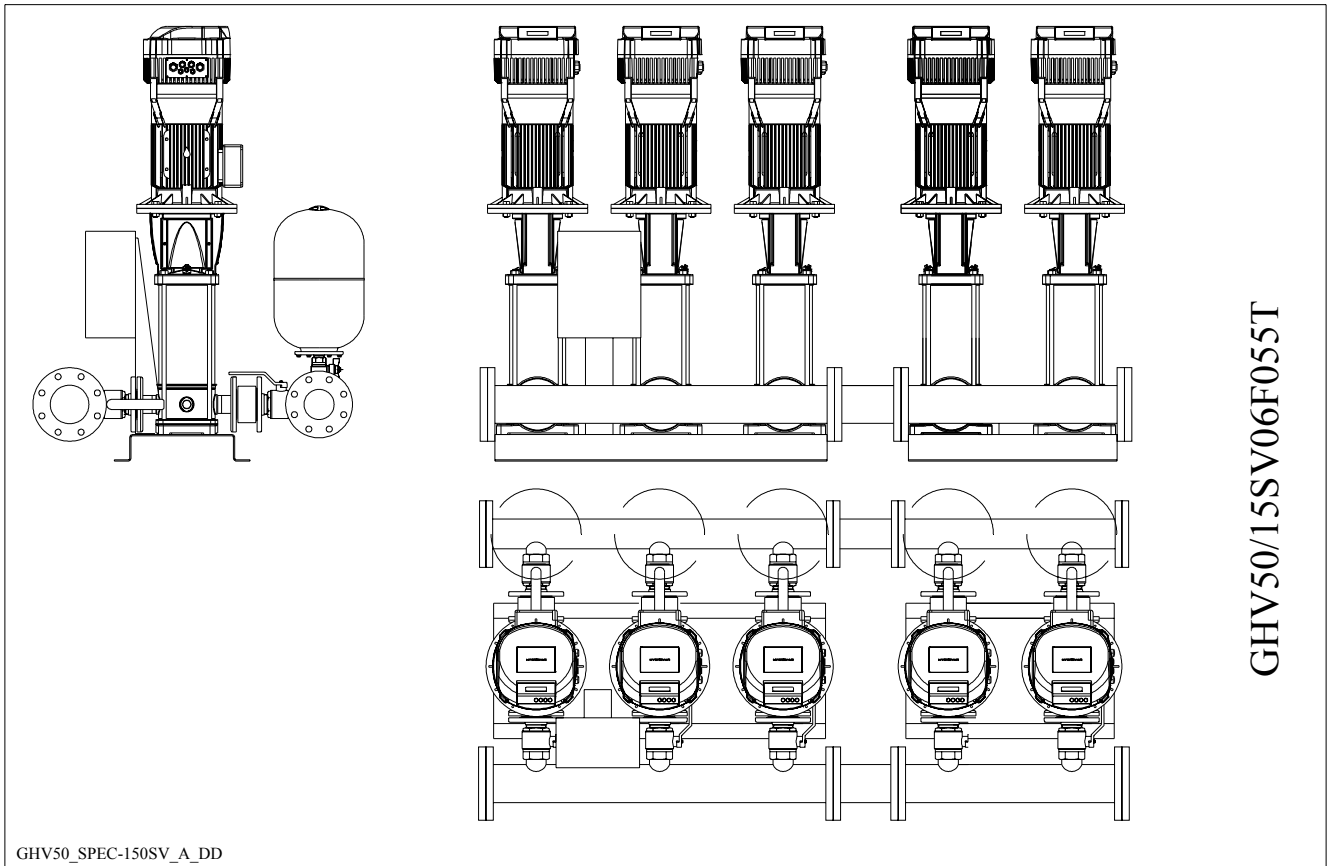

N.B.: Please request other special versions with regard to materials used, working temperatures, electric panels with additional functions.

GHV20

TWO-PUMP BOOSTER SETS, GHV20 SERIES VERTICAL ELECTRIC PUMPS WITH NON-RETURN VALVE ON DELIVERY SIDE. SINGLE-PHASE POWER SUPPLY

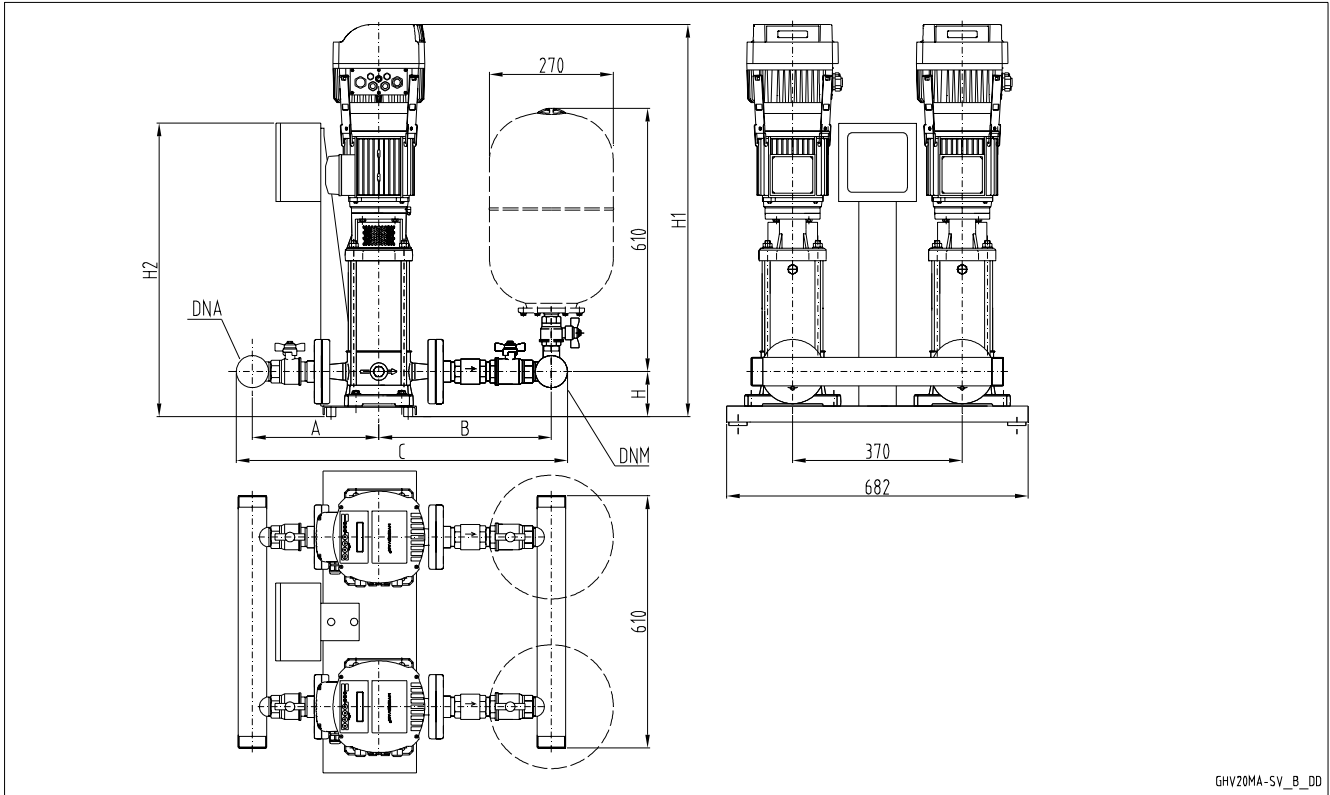

GHV20MA-SV_B_DD

GHV20

GHV 20	DNA	DNM	A		B		C		H	H1	H2
			STD/DW	AISI	STD/DW	AISI	STD/DW	AISI			
3SV05F005T	R 2"	R 2"	252	301	304	346	616	707	109	753	700
3SV06F005T	R 2"	R 2"	252	301	304	346	616	707	109	773	700
3SV07F007T	R 2"	R 2"	252	301	304	346	616	707	109	835	700
3SV08F007T	R 2"	R 2"	252	301	304	346	616	707	109	855	700
3SV09F011T	R 2"	R 2"	252	301	304	346	616	707	109	875	700
3SV10F011T	R 2"	R 2"	252	301	304	346	616	707	109	895	700
3SV11F011T	R 2"	R 2"	252	301	304	346	616	707	109	915	700
3SV12F011T	R 2"	R 2"	252	301	304	346	616	707	109	935	700
3SV13F015T	R 2"	R 2"	252	301	304	346	616	707	109	965	700
3SV14F015T	R 2"	R 2"	252	301	304	346	616	707	109	985	700
3SV16F015T	R 2"	R 2"	252	301	304	346	616	707	109	1025	700
3SV19F022T	R 2"	R 2"	252	301	304	346	616	707	109	1120	700
3SV21F022T	R 2"	R 2"	252	301	304	346	616	707	109	1160	700
5SV03F005T	R 2"	R 2"	265	311	327	431	652	802	109	728	700
5SV04F005T	R 2"	R 2"	265	311	327	431	652	802	109	753	700
5SV05F007T	R 2"	R 2"	265	311	327	431	652	802	109	820	700
5SV06F011T	R 2"	R 2"	265	311	327	431	652	802	109	845	700
5SV07F011T	R 2"	R 2"	265	311	327	431	652	802	109	870	700
5SV08F011T	R 2"	R 2"	265	311	327	431	652	802	109	895	700
5SV09F015T	R 2"	R 2"	265	311	327	431	652	802	109	930	700
5SV10F015T	R 2"	R 2"	265	311	327	431	652	802	109	955	700
5SV11F015T	R 2"	R 2"	265	311	327	431	652	802	109	980	700
5SV12F022T	R 2"	R 2"	265	311	327	431	652	802	109	1040	700
5SV13F022T	R 2"	R 2"	265	311	327	431	652	802	109	1065	700
5SV14F022T	R 2"	R 2"	265	311	327	431	652	802	109	1090	700
5SV15F022T	R 2"	R 2"	265	311	327	431	652	802	109	1115	700
5SV16F022T	R 2"	R 2"	265	311	327	431	652	802	109	1140	700
10SV01F007T	R 2 1/2	R 2 1/2	297	356	362	497	735	929	114	824	700
10SV02F007T	R 2 1/2	R 2 1/2	297	356	362	497	735	929	114	824	700
10SV03F011T	R 2 1/2	R 2 1/2	297	356	362	497	735	929	114	856	700
10SV04F015T	R 2 1/2	R 2 1/2	297	356	362	497	735	929	114	898	700
10SV05F022T	R 2 1/2	R 2 1/2	297	356	362	497	735	929	114	965	700
10SV06F022T	R 2 1/2	R 2 1/2	297	356	362	497	735	929	114	997	700

Dimensions in mm. Tolerance ± 10 mm.

ghvm20_esv-f-en_a_td

TWO-PUMP BOOSTER SETS, GHV20 RA SERIES VERTICAL ELECTRIC Pumps WITH NON-RETURN VALVE ON SUCTION SIDE. SINGLE-PHASE POWER SUPPLY

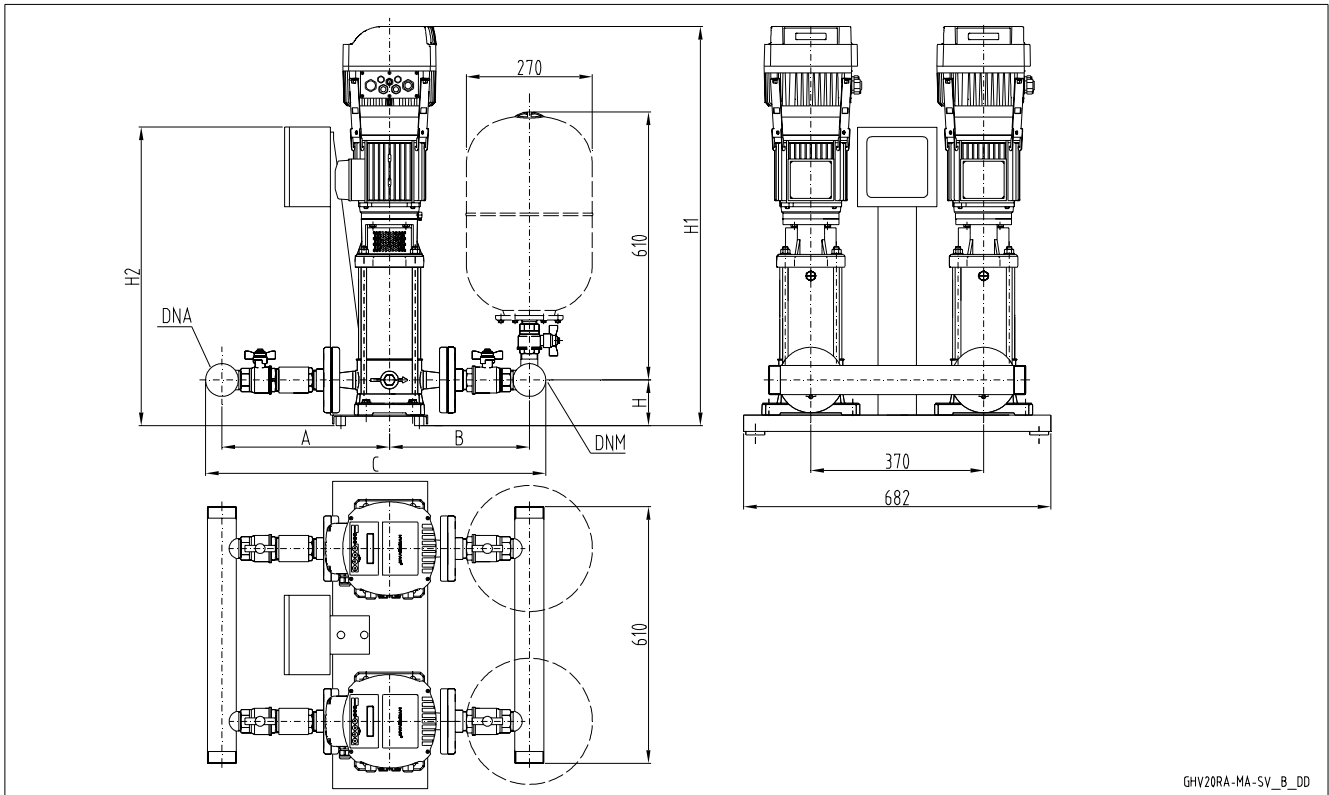

GHV20RA-MA-SV_B_DD

GHV 20RA	DNA	DNM	A		B		C		H	H1	H2
			STD/DW	AISI	STD/DW	AISI	STD/DW	AISI			
3SV05F005T	R 2"	R 2"	297	372	287	301	644	733	109	753	700
3SV06F005T	R 2"	R 2"	297	372	287	301	644	733	109	773	700
3SV07F007T	R 2"	R 2"	297	372	287	301	644	733	109	835	700
3SV08F007T	R 2"	R 2"	297	372	287	301	644	733	109	855	700
3SV09F011T	R 2"	R 2"	297	372	287	301	644	733	109	875	700
3SV10F011T	R 2"	R 2"	297	372	287	301	644	733	109	895	700
3SV11F011T	R 2"	R 2"	297	372	287	301	644	733	109	915	700
3SV12F011T	R 2"	R 2"	297	372	287	301	644	733	109	935	700
3SV13F015T	R 2"	R 2"	297	372	287	301	644	733	109	965	700
3SV14F015T	R 2"	R 2"	297	372	287	301	644	733	109	985	700
3SV16F015T	R 2"	R 2"	297	372	287	301	644	733	109	1025	700
3SV19F022T	R 2"	R 2"	297	372	287	301	644	733	109	1120	700
3SV21F022T	R 2"	R 2"	297	372	287	301	644	733	109	1160	700
5SV03F005T	R 2"	R 2"	318	431	313	311	691	802	109	728	700
5SV04F005T	R 2"	R 2"	318	431	313	311	691	802	109	753	700
5SV05F007T	R 2"	R 2"	318	431	313	311	691	802	109	820	700
5SV06F011T	R 2"	R 2"	318	431	313	311	691	802	109	845	700
5SV07F011T	R 2"	R 2"	318	431	313	311	691	802	109	870	700
5SV08F011T	R 2"	R 2"	318	431	313	311	691	802	109	895	700
5SV09F015T	R 2"	R 2"	318	431	313	311	691	802	109	930	700
5SV10F015T	R 2"	R 2"	318	431	313	311	691	802	109	955	700
5SV11F015T	R 2"	R 2"	318	431	313	311	691	802	109	980	700
5SV12F022T	R 2"	R 2"	318	431	313	311	691	802	109	1040	700
5SV13F022T	R 2"	R 2"	318	431	313	311	691	802	109	1065	700
5SV14F022T	R 2"	R 2"	318	431	313	311	691	802	109	1090	700
5SV15F022T	R 2"	R 2"	318	431	313	311	691	802	109	1115	700
5SV16F022T	R 2"	R 2"	318	431	313	311	691	802	109	1140	700
10SV01F007T	R 2 1/2	R 2 1/2	367	497	345	356	788	929	114	824	700
10SV02F007T	R 2 1/2	R 2 1/2	367	497	345	356	788	929	114	824	700
10SV03F011T	R 2 1/2	R 2 1/2	367	497	345	356	788	929	114	856	700
10SV04F015T	R 2 1/2	R 2 1/2	367	497	345	356	788	929	114	898	700
10SV05F022T	R 2 1/2	R 2 1/2	367	497	345	356	788	929	114	965	700
10SV06F022T	R 2 1/2	R 2 1/2	367	497	345	356	788	929	114	997	700

Dimensions in mm. Tolerance ± 10 mm.

ghvm20ra_esv-f-en_a_td

GHV20

**TWO-PUMP BOOSTER SETS, GHV20 SERIES
VERTICAL ELECTRIC PUMPS WITH NON-RETURN VALVE
ON DELIVERY SIDE. SINGLE-PHASE POWER SUPPLY**

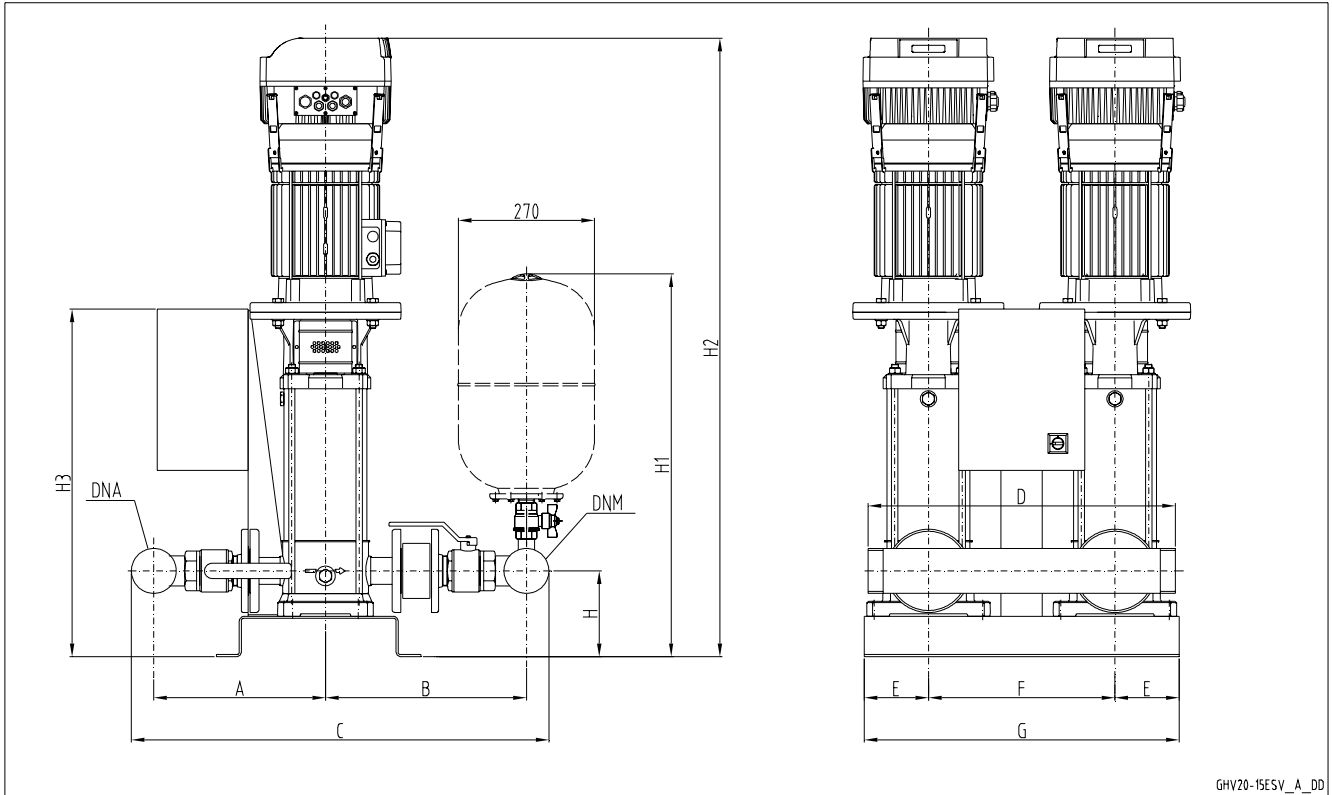

GHV20-15ESV_A_DD

GHV20

GHV 20	DNA	DNM	A		B		C		D	E	F	G	H	H1	H2	H3
			STD/DW	AISI	STD/DW	AISI	STD/DW	AISI								
15SV01F011T	R 3"	R 3"	342	382	399	437	829	907	610	135	370	640	170	765	912	746
15SV02F022T	R 3"	R 3"	342	382	399	437	829	907	610	135	370	640	170	765	957	746
22SV01F011T	R 3"	R 3"	342	382	399	437	829	907	610	135	370	640	170	765	912	746
22SV02F022T	R 3"	R 3"	342	382	399	437	829	907	610	135	370	640	170	765	957	746

Dimensions in mm. Tolerance ± 10 mm.

ghv20m_15esv-small-en_a_td

**TWO-PUMP BOOSTER SETS, GHV20 RA SERIES
VERTICAL ELECTRIC PUMPS WITH NON-RETURN VALVE
ON SUCTION SIDE. SINGLE-PHASE POWER SUPPLY**

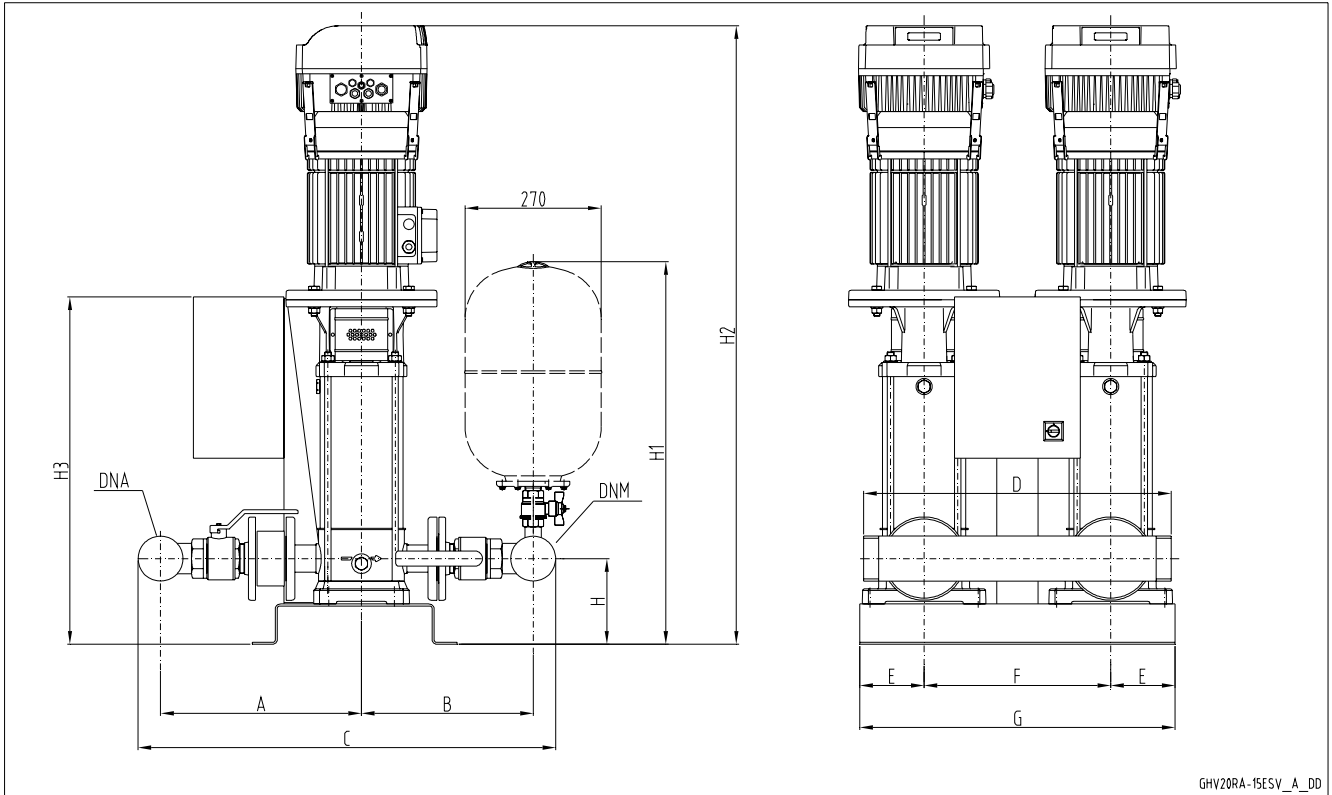

GHV 20 RA	DNA	DNM	A		B		C		D	E	F	G	H	H1	H2	H3
			STD/DW	AISI	STD/DW	AISI	STD/DW	AISI								
15SV01F011T	R 3"	R 3"	399	437	342	380	829	905	610	135	370	640	170	765	912	746
15SV02F022T	R 3"	R 3"	399	437	342	380	829	905	610	135	370	640	170	765	957	746
22SV01F011T	R 3"	R 3"	399	437	342	380	829	905	610	135	370	640	170	765	912	746
22SV02F022T	R 3"	R 3"	399	437	342	380	829	905	610	135	370	640	170	765	957	746

Dimensions in mm. Tolerance ± 10 mm.

ghv20ram_15esv-small-en_a_td

GHV20

TWO-PUMP BOOSTER SETS, GHV20 SERIES VERTICAL ELECTRIC PUMPS WITH NON-RETURN VALVE ON DELIVERY SIDE. SINGLE-PHASE POWER SUPPLY

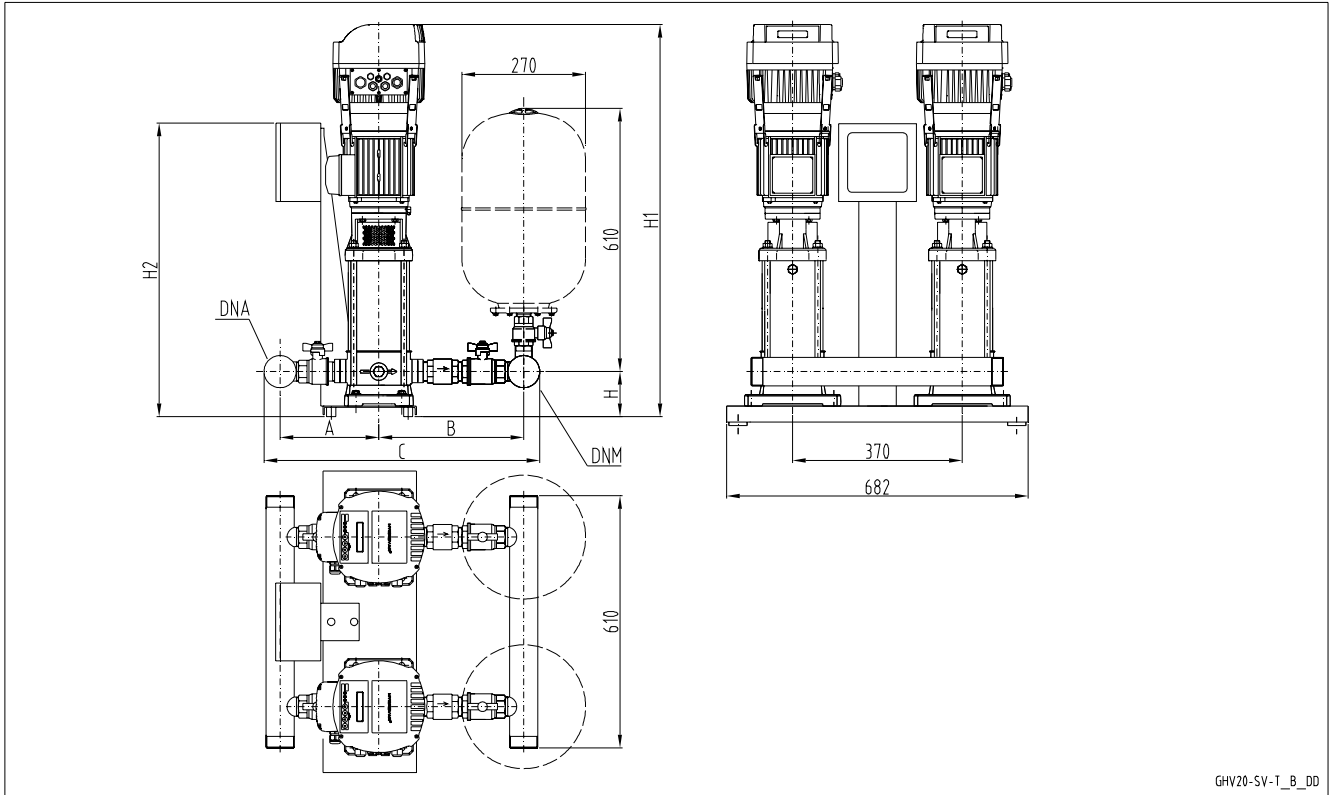

GHV20-SV-T_B_DD

GHV20

GHV 20	DNA	DNM	A		B		C		H	H1	H2
			STD/DW	AISI	STD/DW	AISI	STD/DW	AISI			
3SV05T005T	R 2"	R 2"	233	312	285	367	578	739	84	728	700
3SV06T005T	R 2"	R 2"	233	312	285	367	578	739	84	748	700
3SV07T007T	R 2"	R 2"	233	312	285	367	578	739	84	810	700
3SV08T007T	R 2"	R 2"	233	312	285	367	578	739	84	830	700
3SV09T011T	R 2"	R 2"	233	312	285	367	578	739	84	850	700
3SV10T011T	R 2"	R 2"	233	312	285	367	578	739	84	870	700
3SV11T011T	R 2"	R 2"	233	312	285	367	578	739	84	890	700
3SV12T011T	R 2"	R 2"	233	312	285	367	578	739	84	910	700
3SV13T015T	R 2"	R 2"	233	312	285	367	578	739	84	940	700
3SV14T015T	R 2"	R 2"	233	312	285	367	578	739	84	960	700
3SV16T015T	R 2"	R 2"	233	312	285	367	578	739	84	1000	700
3SV19T022T	R 2"	R 2"	233	312	285	367	578	739	84	1095	700
3SV21T022T	R 2"	R 2"	233	312	285	367	578	739	84	1135	700
5SV03T005T	R 2"	R 2"	248	336	310	403	618	799	84	703	700
5SV04T005T	R 2"	R 2"	248	336	310	403	618	799	84	728	700
5SV05T007T	R 2"	R 2"	248	336	310	403	618	799	84	795	700
5SV06T011T	R 2"	R 2"	248	336	310	403	618	799	84	820	700
5SV07T011T	R 2"	R 2"	248	336	310	403	618	799	84	845	700
5SV08T011T	R 2"	R 2"	248	336	310	403	618	799	84	870	700
5SV09T015T	R 2"	R 2"	248	336	310	403	618	799	84	905	700
5SV10T015T	R 2"	R 2"	248	336	310	403	618	799	84	930	700
5SV11T015T	R 2"	R 2"	248	336	310	403	618	799	84	955	700
5SV12T022T	R 2"	R 2"	248	336	310	403	618	799	84	1015	700
5SV13T022T	R 2"	R 2"	248	336	310	403	618	799	84	1040	700
5SV14T022T	R 2"	R 2"	248	336	310	403	618	799	84	1065	700
5SV15T022T	R 2"	R 2"	248	336	310	403	618	799	84	1090	700
5SV16T022T	R 2"	R 2"	248	336	310	403	618	799	84	1115	700
10SV01T007T	R 2 1/2	R 2 1/2	291	386	356	471	723	933	114	824	700
10SV02T007T	R 2 1/2	R 2 1/2	291	386	356	471	723	933	114	824	700
10SV03T011T	R 2 1/2	R 2 1/2	291	386	356	471	723	933	114	856	700
10SV04T015T	R 2 1/2	R 2 1/2	291	386	356	471	723	933	114	898	700
10SV05T022T	R 2 1/2	R 2 1/2	291	386	356	471	723	933	114	965	700
10SV06T022T	R 2 1/2	R 2 1/2	291	386	356	471	723	933	114	997	700

Dimensions in mm. Tolerance ± 10 mm.

ghvm20_esh-t-en_a_td

TWO-PUMP BOOSTER SETS, GHV20 RA SERIES VERTICAL ELECTRIC PUMPS WITH NON-RETURN VALVE ON SUCTION SIDE. SINGLE-PHASE POWER SUPPLY

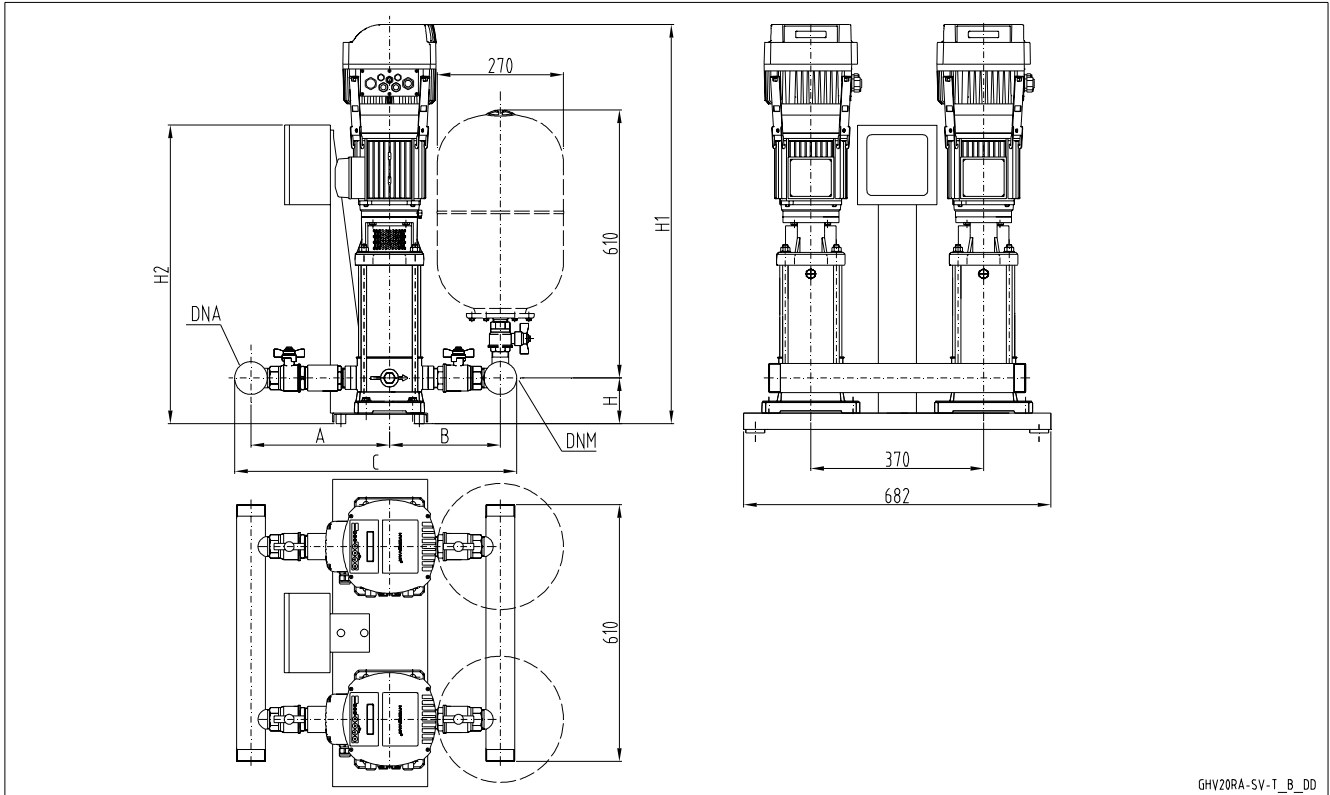

GHV20RA-SV-T_B_DD

GHV 20RA	DNA	DNM	A		B		C		H	H1	H2
			STD/DW	AISI	STD/DW	AISI	STD/DW	AISI			
3SV05T005T	R 2"	R 2"	285	367	268	312	613	739	84	728	700
3SV06T005T	R 2"	R 2"	285	367	268	312	613	739	84	748	700
3SV07T007T	R 2"	R 2"	285	367	268	312	613	739	84	810	700
3SV08T007T	R 2"	R 2"	285	367	268	312	613	739	84	830	700
3SV09T011T	R 2"	R 2"	285	367	268	312	613	739	84	850	700
3SV10T011T	R 2"	R 2"	285	367	268	312	613	739	84	870	700
3SV11T011T	R 2"	R 2"	285	367	268	312	613	739	84	890	700
3SV12T011T	R 2"	R 2"	285	367	268	312	613	739	84	910	700
3SV13T015T	R 2"	R 2"	285	367	268	312	613	739	84	940	700
3SV14T015T	R 2"	R 2"	285	367	268	312	613	739	84	960	700
3SV16T015T	R 2"	R 2"	285	367	268	312	613	739	84	1000	700
3SV19T022T	R 2"	R 2"	285	367	268	312	613	739	84	1095	700
3SV21T022T	R 2"	R 2"	285	367	268	312	613	739	84	1135	700
5SV03T005T	R 2"	R 2"	310	403	296	336	666	799	84	703	700
5SV04T005T	R 2"	R 2"	310	403	296	336	666	799	84	728	700
5SV05T007T	R 2"	R 2"	310	403	296	336	666	799	84	795	700
5SV06T011T	R 2"	R 2"	310	403	296	336	666	799	84	820	700
5SV07T011T	R 2"	R 2"	310	403	296	336	666	799	84	845	700
5SV08T011T	R 2"	R 2"	310	403	296	336	666	799	84	870	700
5SV09T015T	R 2"	R 2"	310	403	296	336	666	799	84	905	700
5SV10T015T	R 2"	R 2"	310	403	296	336	666	799	84	930	700
5SV11T015T	R 2"	R 2"	310	403	296	336	666	799	84	955	700
5SV12T022T	R 2"	R 2"	310	403	296	336	666	799	84	1015	700
5SV13T022T	R 2"	R 2"	310	403	296	336	666	799	84	1040	700
5SV14T022T	R 2"	R 2"	310	403	296	336	666	799	84	1065	700
5SV15T022T	R 2"	R 2"	310	403	296	336	666	799	84	1090	700
5SV16T022T	R 2"	R 2"	310	403	296	336	666	799	84	1115	700
10SV01T007T	R 2 1/2"	R 2 1/2"	356	471	339	386	771	933	114	824	700
10SV02T007T	R 2 1/2"	R 2 1/2"	356	471	339	386	771	933	114	824	700
10SV03T011T	R 2 1/2"	R 2 1/2"	356	471	339	386	771	933	114	856	700
10SV04T015T	R 2 1/2"	R 2 1/2"	356	471	339	386	771	933	114	898	700
10SV05T022T	R 2 1/2"	R 2 1/2"	356	471	339	386	771	933	114	965	700
10SV06T022T	R 2 1/2"	R 2 1/2"	356	471	339	386	771	933	114	997	700

Dimensions in mm. Tolerance ± 10 mm.

ghvm20ra_esv-t-en_a_td

TWO-PUMP BOOSTER SETS, GHV20 SERIES VERTICAL ELECTRIC PUMPS WITH NON-RETURN VALVE ON DELIVERY SIDE. THREE-PHASE POWER SUPPLY

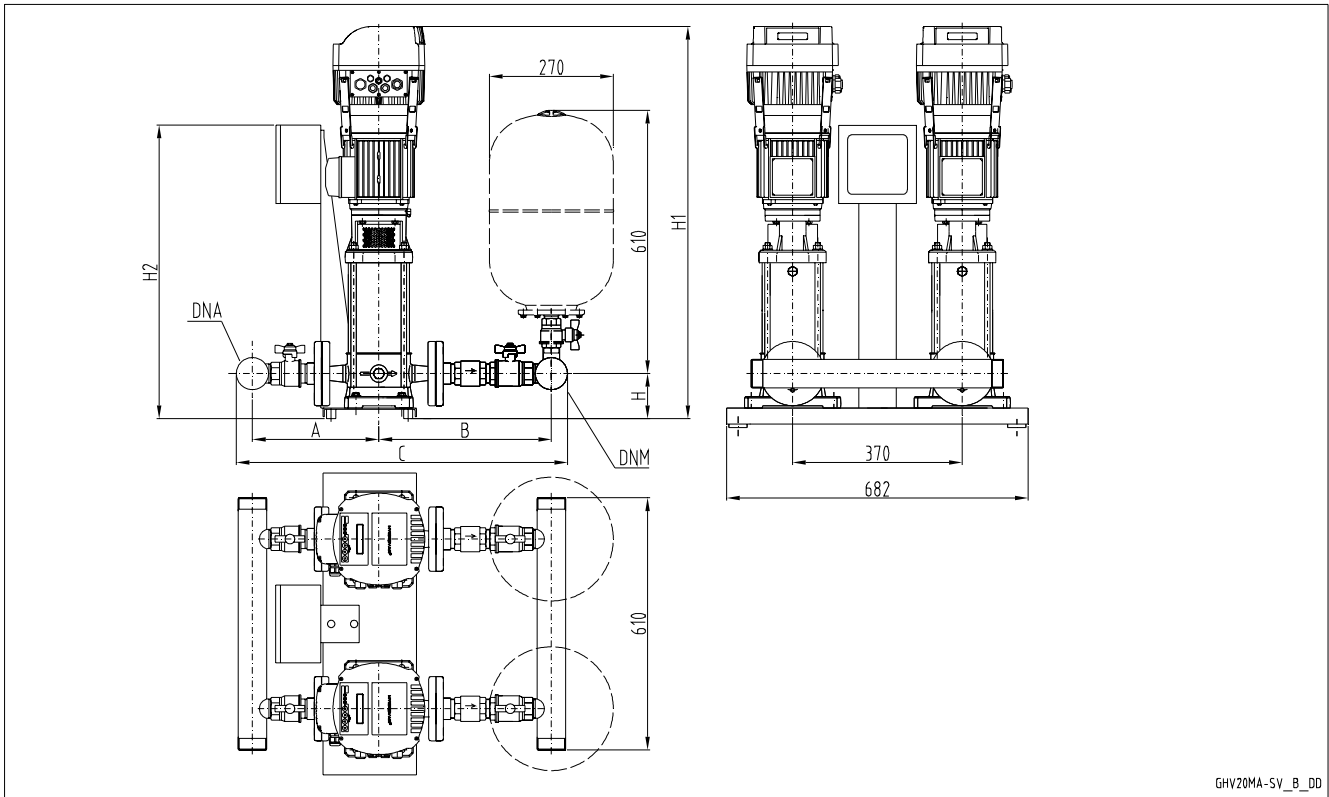

GHV20MA-SV_B_DD

GHV20

GHV 20	DNA	DNM	A		B		C		H	H1	H2
			STD/DW	AISI	STD/DW	AISI	STD/DW	AISI			
3SV09F011T	R 2"	R 2"	252	301	304	301	616	707	109	875	700
3SV10F011T	R 2"	R 2"	252	301	304	301	616	707	109	895	700
3SV11F011T	R 2"	R 2"	252	301	304	301	616	707	109	915	700
3SV12F011T	R 2"	R 2"	252	301	304	301	616	707	109	935	700
3SV13F015T	R 2"	R 2"	252	301	304	301	616	707	109	965	700
3SV14F015T	R 2"	R 2"	252	301	304	301	616	707	109	985	700
3SV16F015T	R 2"	R 2"	252	301	304	301	616	707	109	1025	700
3SV19F022T	R 2"	R 2"	252	301	304	301	616	707	109	1120	700
3SV21F022T	R 2"	R 2"	252	301	304	301	616	707	109	1160	700
5SV06F011T	R 2"	R 2"	265	311	327	311	652	802	109	845	700
5SV07F011T	R 2"	R 2"	265	311	327	311	652	802	109	870	700
5SV08F011T	R 2"	R 2"	265	311	327	311	652	802	109	895	700
5SV09F015T	R 2"	R 2"	265	311	327	311	652	802	109	930	700
5SV10F015T	R 2"	R 2"	265	311	327	311	652	802	109	955	700
5SV11F015T	R 2"	R 2"	265	311	327	311	652	802	109	980	700
5SV12F022T	R 2"	R 2"	265	311	327	311	652	802	109	1040	700
5SV13F022T	R 2"	R 2"	265	311	327	311	652	802	109	1065	700
5SV14F022T	R 2"	R 2"	265	311	327	311	652	802	109	1090	700
5SV15F022T	R 2"	R 2"	265	311	327	311	652	802	109	1115	700
5SV16F022T	R 2"	R 2"	265	311	327	311	652	802	109	1140	700
5SV18F030T	R 2"	R 2"	265	311	327	311	652	802	109	1200	700
5SV21F030T	R 2"	R 2"	265	311	327	311	652	802	109	1275	700
10SV03F011T	R 2 1/2	R 2 1/2	297	356	362	356	735	929	114	856	700
10SV04F015T	R 2 1/2	R 2 1/2	297	356	362	356	735	929	114	898	700
10SV05F022T	R 2 1/2	R 2 1/2	297	356	362	356	735	929	114	965	700
10SV06F022T	R 2 1/2	R 2 1/2	297	356	362	356	735	929	114	997	700
10SV07F030T	R 2 1/2	R 2 1/2	297	356	362	356	735	929	114	1039	700
10SV08F030T	R 2 1/2	R 2 1/2	297	356	362	356	735	929	114	1071	700
10SV09F040T	R 2 1/2	R 2 1/2	297	356	362	356	735	929	114	1124	700
10SV10F040T	R 2 1/2	R 2 1/2	297	356	362	356	735	929	114	1156	700
10SV11F040T	R 2 1/2	R 2 1/2	297	356	362	356	735	929	114	1188	700

Dimensions in mm. Tolerance ± 10 mm.

ghvt20_esh-f-en_a_td

TWO-PUMP BOOSTER SETS, GHV20 RA SERIES VERTICAL ELECTRIC Pumps WITH NON-RETURN VALVE ON SUCTION SIDE. THREE-PHASE POWER SUPPLY

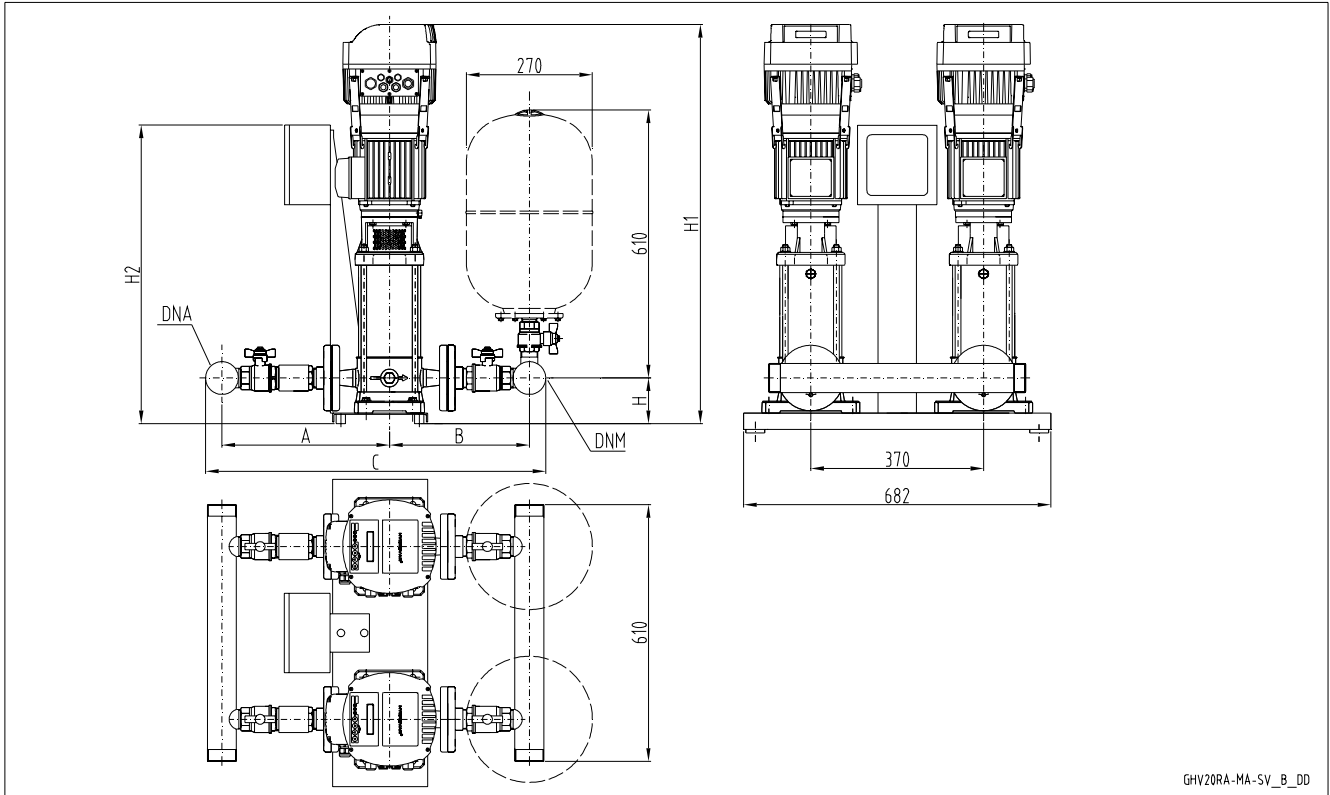

GHV20RA-MA-SV_B_DD

GHV 20RA	DNA	DNM	A		B		C		H	H1	H2
			STD/DW	AISI	STD/DW	AISI	STD/DW	AISI			
3SV09F011T	R 2"	R 2"	297	372	287	301	644	733	109	875	700
3SV10F011T	R 2"	R 2"	297	372	287	301	644	733	109	895	700
3SV11F011T	R 2"	R 2"	297	372	287	301	644	733	109	915	700
3SV12F011T	R 2"	R 2"	297	372	287	301	644	733	109	935	700
3SV13F015T	R 2"	R 2"	297	372	287	301	644	733	109	965	700
3SV14F015T	R 2"	R 2"	297	372	287	301	644	733	109	985	700
3SV16F015T	R 2"	R 2"	297	372	287	301	644	733	109	1025	700
3SV19F022T	R 2"	R 2"	297	372	287	301	644	733	109	1120	700
3SV21F022T	R 2"	R 2"	297	372	287	301	644	733	109	1160	700
5SV06F011T	R 2"	R 2"	318	431	313	311	691	802	109	845	700
5SV07F011T	R 2"	R 2"	318	431	313	311	691	802	109	870	700
5SV08F011T	R 2"	R 2"	318	431	313	311	691	802	109	895	700
5SV09F015T	R 2"	R 2"	318	431	313	311	691	802	109	930	700
5SV10F015T	R 2"	R 2"	318	431	313	311	691	802	109	955	700
5SV11F015T	R 2"	R 2"	318	431	313	311	691	802	109	980	700
5SV12F022T	R 2"	R 2"	318	431	313	311	691	802	109	1040	700
5SV13F022T	R 2"	R 2"	318	431	313	311	691	802	109	1065	700
5SV14F022T	R 2"	R 2"	318	431	313	311	691	802	109	1090	700
5SV15F022T	R 2"	R 2"	318	431	313	311	691	802	109	1115	700
5SV16F022T	R 2"	R 2"	318	431	313	311	691	802	109	1140	700
5SV18F030T	R 2"	R 2"	318	431	313	311	691	802	109	1200	700
5SV21F030T	R 2"	R 2"	318	431	313	311	691	802	109	1275	700
10SV03F011T	R 2 1/2	R 2 1/2	367	497	345	356	788	929	114	856	700
10SV04F015T	R 2 1/2	R 2 1/2	367	497	345	356	788	929	114	898	700
10SV05F022T	R 2 1/2	R 2 1/2	367	497	345	356	788	929	114	965	700
10SV06F022T	R 2 1/2	R 2 1/2	367	497	345	356	788	929	114	997	700
10SV07F030T	R 2 1/2	R 2 1/2	367	497	345	356	788	929	114	1039	700
10SV08F030T	R 2 1/2	R 2 1/2	367	497	345	356	788	929	114	1071	700
10SV09F040T	R 2 1/2	R 2 1/2	367	497	345	356	788	929	114	1124	700
10SV10F040T	R 2 1/2	R 2 1/2	367	497	345	356	788	929	114	1156	700
10SV11F040T	R 2 1/2	R 2 1/2	367	497	345	356	788	929	114	1188	700

Dimensions in mm. Tolerance ± 10 mm.

ghvt20ra_esv-f-en_a_td

GHV20

**TWO-PUMP BOOSTER SETS, GHV20 SERIES
VERTICAL ELECTRIC PUMPS WITH NON-RETURN VALVE
ON DELIVERY SIDE. THREE-PHASE POWER SUPPLY**

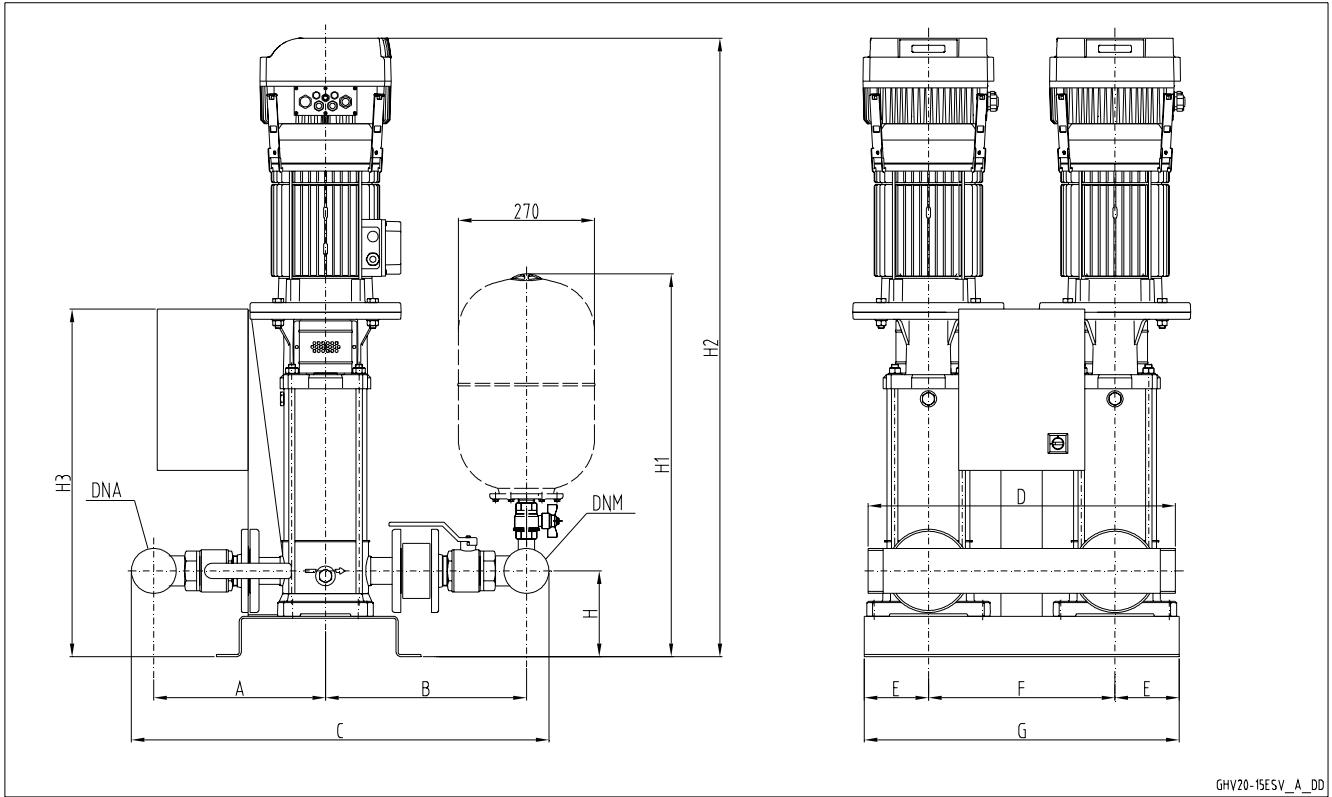

GHV20

GHV 20	DNA	DNM	A		B		C		D	E	F	G	H	H1	H2	H3
			STD/DW	AISI	STD/DW	AISI	STD/DW	AISI								
15SV01F011T	R 3"	R 3"	342	382	399	437	829	907	610	135	370	640	170	765	912	746
15SV02F022T	R 3"	R 3"	342	382	399	437	829	907	610	135	370	640	170	765	957	746
15SV03F030T	R 3"	R 3"	342	382	399	437	829	907	610	135	370	640	170	765	1015	746
15SV04F040T	R 3"	R 3"	342	382	399	437	829	907	610	135	370	640	170	765	1084	746
15SV05F040T	R 3"	R 3"	342	382	399	437	829	907	610	135	370	640	170	765	1132	746
22SV01F011T	R 3"	R 3"	342	382	399	437	829	907	610	135	370	640	170	765	912	746
22SV02F022T	R 3"	R 3"	342	382	399	437	829	907	610	135	370	640	170	765	957	746
22SV03F030T	R 3"	R 3"	342	382	399	437	829	907	610	135	370	640	170	765	1015	746
22SV04F040T	R 3"	R 3"	342	382	399	437	829	907	610	135	370	640	170	765	1084	746

Dimensions in mm. Tolerance ± 10 mm.

ghv20t_15esv-small-en_a_td

**TWO-PUMP BOOSTER SETS, GHV20 RA SERIES
VERTICAL ELECTRIC PUMPS WITH NON-RETURN VALVE
ON SUCTION SIDE. THREE-PHASE POWER SUPPLY**

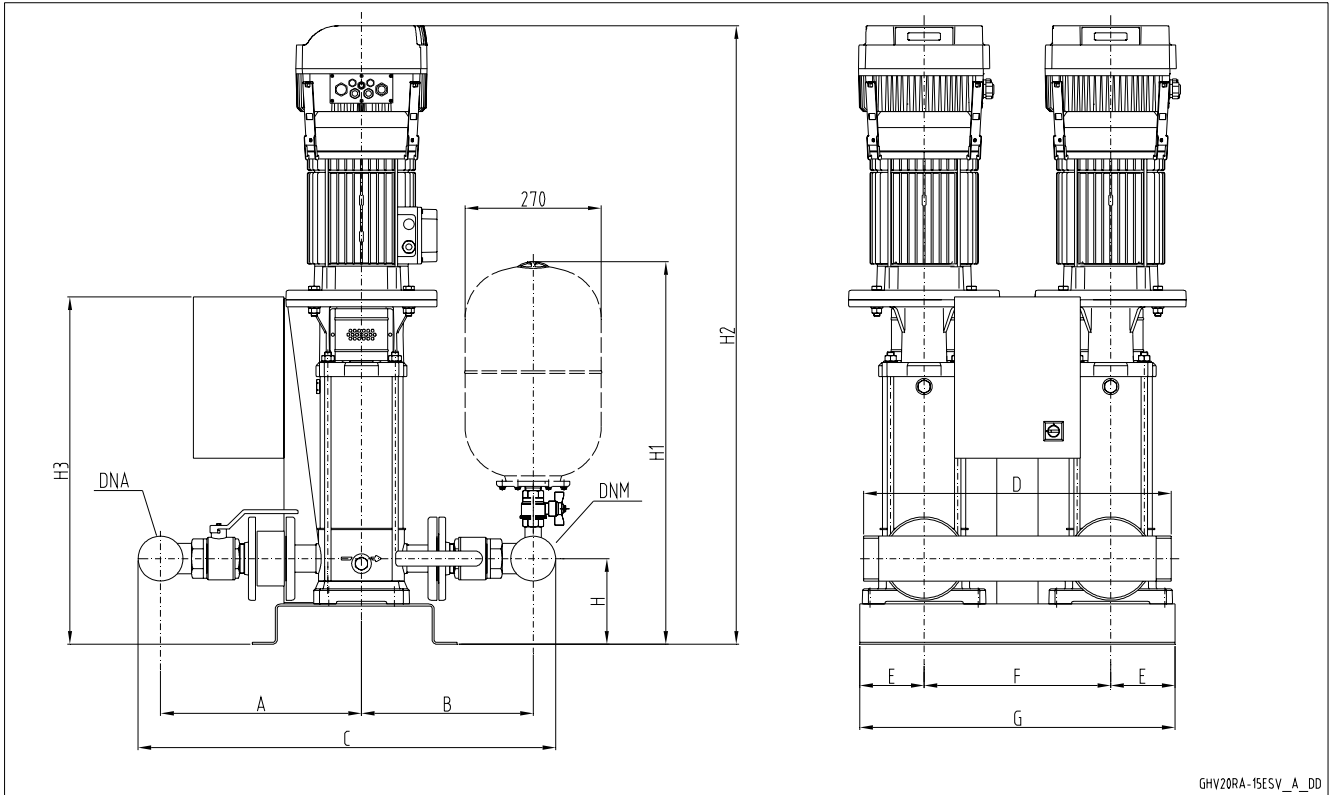

GHV20RA-15ESV_A_DD

GHV 20 RA	DNA	DNM	A		B		C		D	E	F	G	H	H1	H2	H3
			STD/DW	AISI	STD/DW	AISI	STD/DW	AISI								
15SV01F011T	R 3"	R 3"	399	437	342	380	829	905	610	135	370	640	170	765	912	746
15SV02F022T	R 3"	R 3"	399	437	342	380	829	905	610	135	370	640	170	765	957	746
15SV03F030T	R 3"	R 3"	399	437	342	380	829	905	610	135	370	640	170	765	1015	746
15SV04F040T	R 3"	R 3"	399	437	342	380	829	905	610	135	370	640	170	765	1084	746
15SV05F040T	R 3"	R 3"	399	437	342	380	829	905	610	135	370	640	170	765	1132	746
22SV01F011T	R 3"	R 3"	399	437	342	380	829	905	610	135	370	640	170	765	912	746
22SV02F022T	R 3"	R 3"	399	437	342	380	829	905	610	135	370	640	170	765	957	746
22SV03F030T	R 3"	R 3"	399	437	342	380	829	905	610	135	370	640	170	765	1015	746
22SV04F040T	R 3"	R 3"	399	437	342	380	829	905	610	135	370	640	170	765	1084	746

Dimensions in mm. Tolerance ± 10 mm.

ghv20rat_15esv-small-en_a_td

GHV20

TWO-PUMP BOOSTER SETS, GHV20 SERIES VERTICAL ELECTRIC PUMPS WITH NON-RETURN VALVE ON DELIVERY SIDE. THREE-PHASE POWER SUPPLY

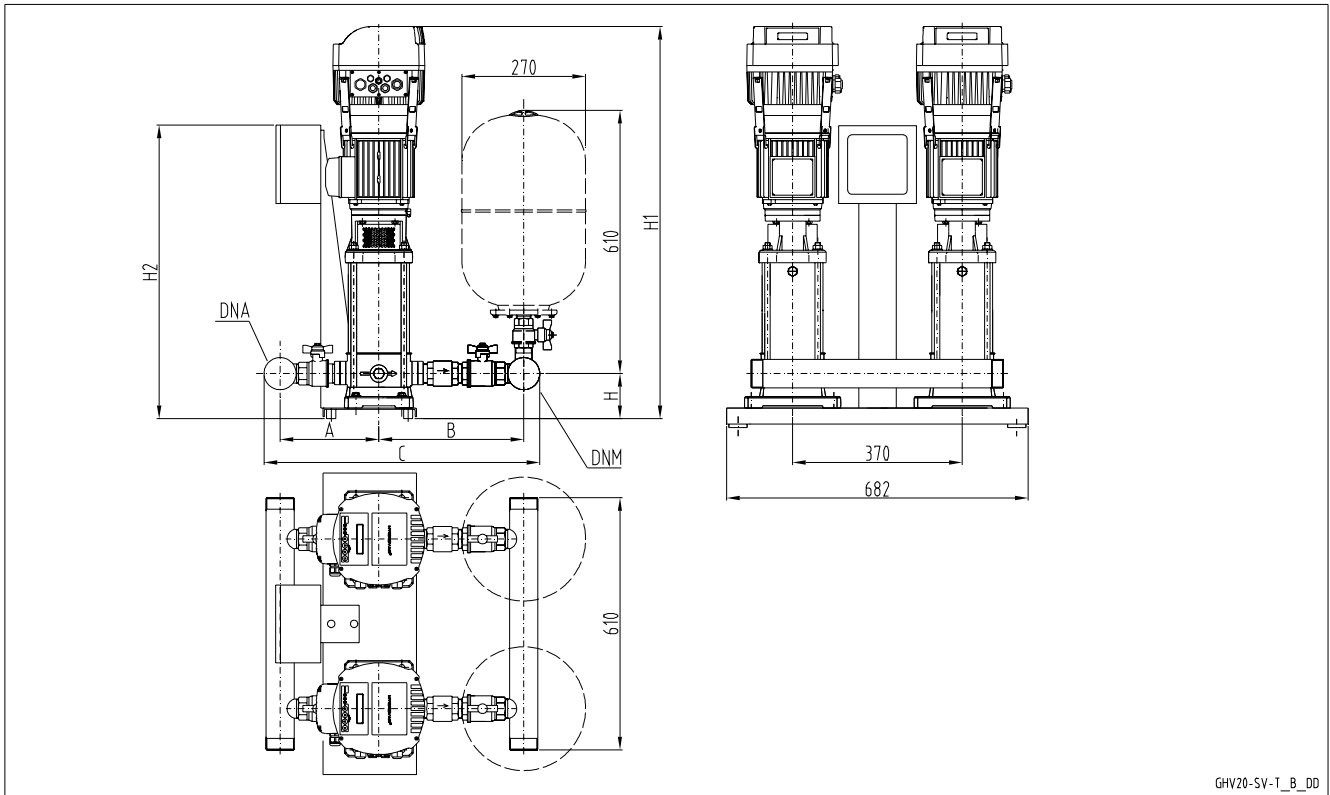

GHV20-SV-T_B_DD

GHV20

GHV 20	DNA	DNM	A		B		C		H	H1	H2
			STD/DW	AISI	STD/DW	AISI	STD/DW	AISI			
3SV09T011T	R 2"	R 2"	233	312	285	367	578	739	84	850	700
3SV10T011T	R 2"	R 2"	233	312	285	367	578	739	84	870	700
3SV11T011T	R 2"	R 2"	233	312	285	367	578	739	84	890	700
3SV12T011T	R 2"	R 2"	233	312	285	367	578	739	84	910	700
3SV13T015T	R 2"	R 2"	233	312	285	367	578	739	84	940	700
3SV14T015T	R 2"	R 2"	233	312	285	367	578	739	84	960	700
3SV16T015T	R 2"	R 2"	233	312	285	367	578	739	84	1000	700
3SV19T022T	R 2"	R 2"	233	312	285	367	578	739	84	1095	700
3SV21T022T	R 2"	R 2"	233	312	285	367	578	739	84	1135	700
5SV06T011T	R 2"	R 2"	248	336	310	403	618	799	84	820	700
5SV07T011T	R 2"	R 2"	248	336	310	403	618	799	84	845	700
5SV08T011T	R 2"	R 2"	248	336	310	403	618	799	84	870	700
5SV09T015T	R 2"	R 2"	248	336	310	403	618	799	84	905	700
5SV10T015T	R 2"	R 2"	248	336	310	403	618	799	84	930	700
5SV11T015T	R 2"	R 2"	248	336	310	403	618	799	84	955	700
5SV12T022T	R 2"	R 2"	248	336	310	403	618	799	84	1015	700
5SV13T022T	R 2"	R 2"	248	336	310	403	618	799	84	1040	700
5SV14T022T	R 2"	R 2"	248	336	310	403	618	799	84	1065	700
5SV15T022T	R 2"	R 2"	248	336	310	403	618	799	84	1090	700
5SV16T022T	R 2"	R 2"	248	336	310	403	618	799	84	1115	700
5SV18T030T	R 2"	R 2"	248	336	310	403	618	799	84	1175	700
5SV21T030T	R 2"	R 2"	248	336	310	403	618	799	84	1250	700
10SV03T011T	R 2 1/2	R 2 1/2	291	386	356	471	723	933	114	856	700
10SV04T015T	R 2 1/2	R 2 1/2	291	386	356	471	723	933	114	898	700
10SV05T022T	R 2 1/2	R 2 1/2	291	386	356	471	723	933	114	965	700
10SV06T022T	R 2 1/2	R 2 1/2	291	386	356	471	723	933	114	997	700
10SV07T030T	R 2 1/2	R 2 1/2	291	386	356	471	723	933	114	1039	700
10SV08T030T	R 2 1/2	R 2 1/2	291	386	356	471	723	933	114	1071	700
10SV09T040T	R 2 1/2	R 2 1/2	291	386	356	471	723	933	114	1124	700
10SV10T040T	R 2 1/2	R 2 1/2	291	386	356	471	723	933	114	1156	700
10SV11T040T	R 2 1/2	R 2 1/2	291	386	356	471	723	933	114	1188	700

Dimensions in mm. Tolerance ± 10 mm.

ghvt20_esh-t-en_a_td

TWO-PUMP BOOSTER SETS, GHV20 RA SERIES VERTICAL ELECTRIC PUMPS WITH NON-RETURN VALVE ON SUCTION SIDE. THREE-PHASE POWER SUPPLY

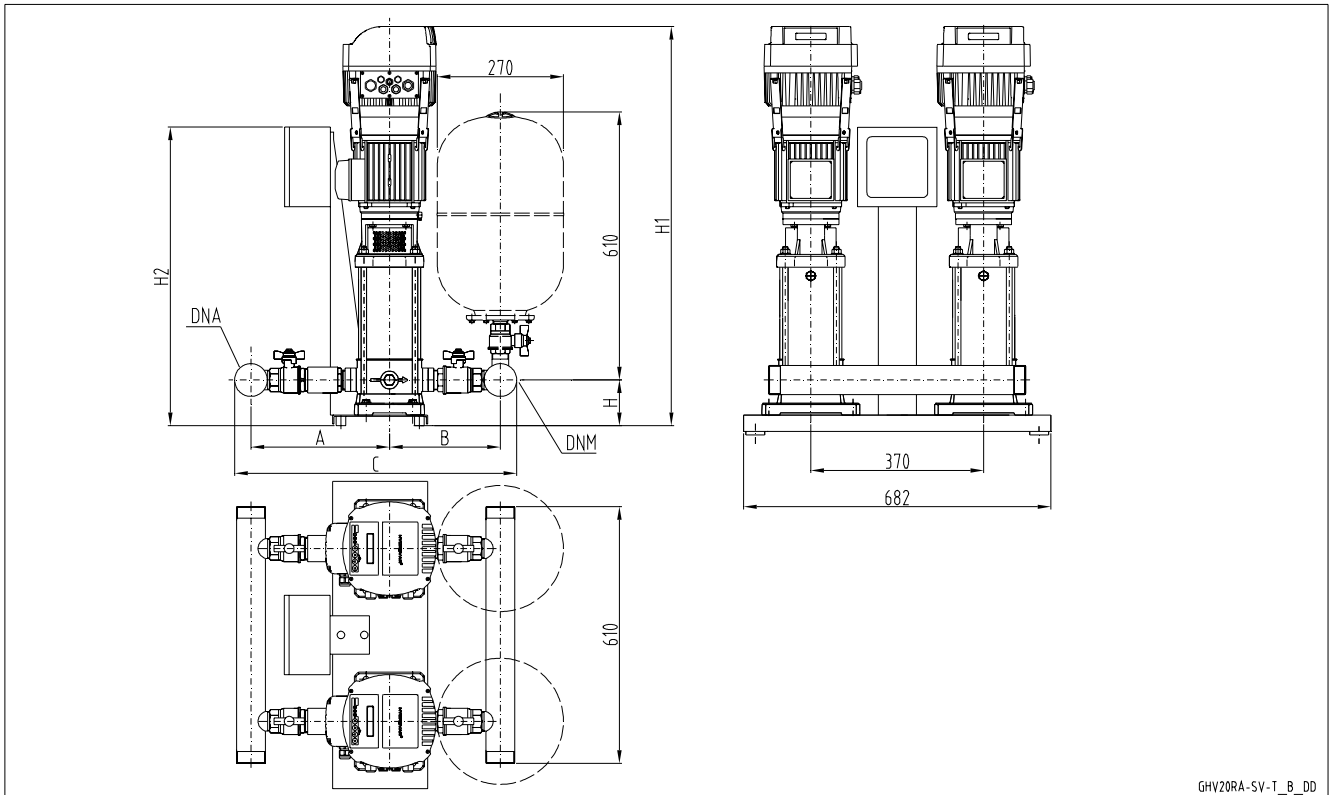

GHV20RA-SV-T_B_DD

GHV 20RA	DNA	DNM	A		B		C		H	H1	H2
			STD/DW	AISI	STD/DW	AISI	STD/DW	AISI			
3SV09T011T	R 2"	R 2"	285	367	268	312	613	739	84	850	700
3SV10T011T	R 2"	R 2"	285	367	268	312	613	739	84	870	700
3SV11T011T	R 2"	R 2"	285	367	268	312	613	739	84	890	700
3SV12T011T	R 2"	R 2"	285	367	268	312	613	739	84	910	700
3SV13T015T	R 2"	R 2"	285	367	268	312	613	739	84	940	700
3SV14T015T	R 2"	R 2"	285	367	268	312	613	739	84	960	700
3SV16T015T	R 2"	R 2"	285	367	268	312	613	739	84	1000	700
3SV19T022T	R 2"	R 2"	285	367	268	312	613	739	84	1095	700
3SV21T022T	R 2"	R 2"	285	367	268	312	613	739	84	1135	700
5SV06T011T	R 2"	R 2"	310	403	296	336	666	799	84	820	700
5SV07T011T	R 2"	R 2"	310	403	296	336	666	799	84	845	700
5SV08T011T	R 2"	R 2"	310	403	296	336	666	799	84	870	700
5SV09T015T	R 2"	R 2"	310	403	296	336	666	799	84	905	700
5SV10T015T	R 2"	R 2"	310	403	296	336	666	799	84	930	700
5SV11T015T	R 2"	R 2"	310	403	296	336	666	799	84	955	700
5SV12T022T	R 2"	R 2"	310	403	296	336	666	799	84	1015	700
5SV13T022T	R 2"	R 2"	310	403	296	336	666	799	84	1040	700
5SV14T022T	R 2"	R 2"	310	403	296	336	666	799	84	1065	700
5SV15T022T	R 2"	R 2"	310	403	296	336	666	799	84	1090	700
5SV16T022T	R 2"	R 2"	310	403	296	336	666	799	84	1115	700
5SV18T030T	R 2"	R 2"	310	403	296	336	666	799	84	1175	700
5SV21T030T	R 2"	R 2"	310	403	296	336	666	799	84	1250	700
10SV03T011T	R 2 1/2	R 2 1/2	356	471	339	386	771	933	114	856	700
10SV04T015T	R 2 1/2	R 2 1/2	356	471	339	386	771	933	114	898	700
10SV05T022T	R 2 1/2	R 2 1/2	356	471	339	386	771	933	114	965	700
10SV06T022T	R 2 1/2	R 2 1/2	356	471	339	386	771	933	114	997	700
10SV07T030T	R 2 1/2	R 2 1/2	356	471	339	386	771	933	114	1039	700
10SV08T030T	R 2 1/2	R 2 1/2	356	471	339	386	771	933	114	1071	700
10SV09T040T	R 2 1/2	R 2 1/2	356	471	339	386	771	933	114	1124	700
10SV10T040T	R 2 1/2	R 2 1/2	356	471	339	386	771	933	114	1156	700
10SV11T040T	R 2 1/2	R 2 1/2	356	471	339	386	771	933	114	1188	700

Dimensions in mm. Tolerance ± 10 mm.

ghvt20ra_esv-t-en_a_td

GHV20

TWO-PUMP BOOSTER SETS OPERATING CHARACTERISTICS AT 50 Hz

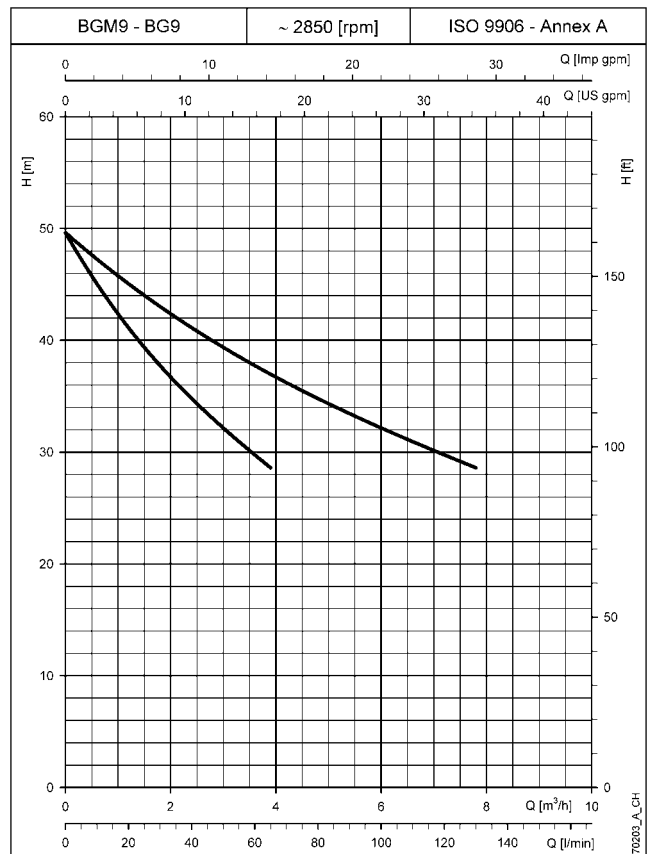
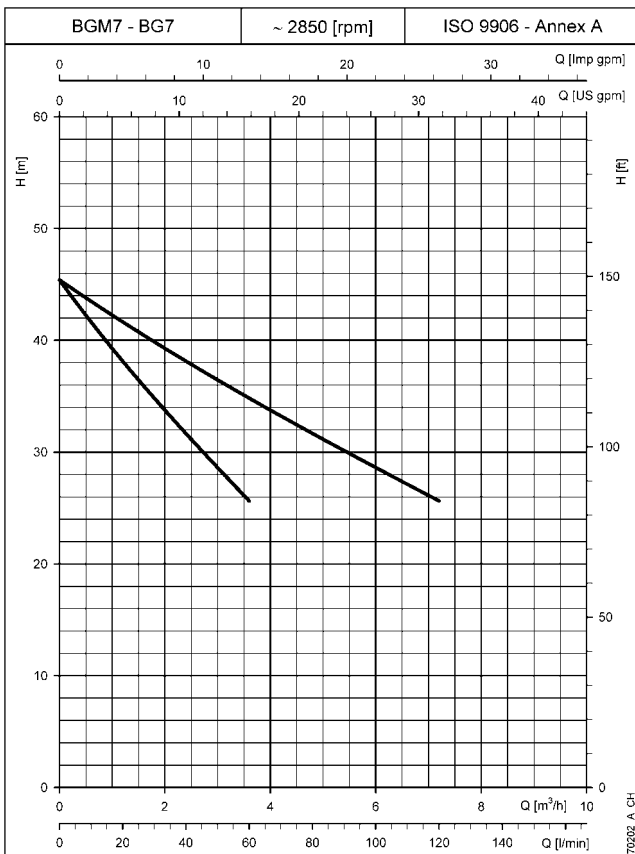
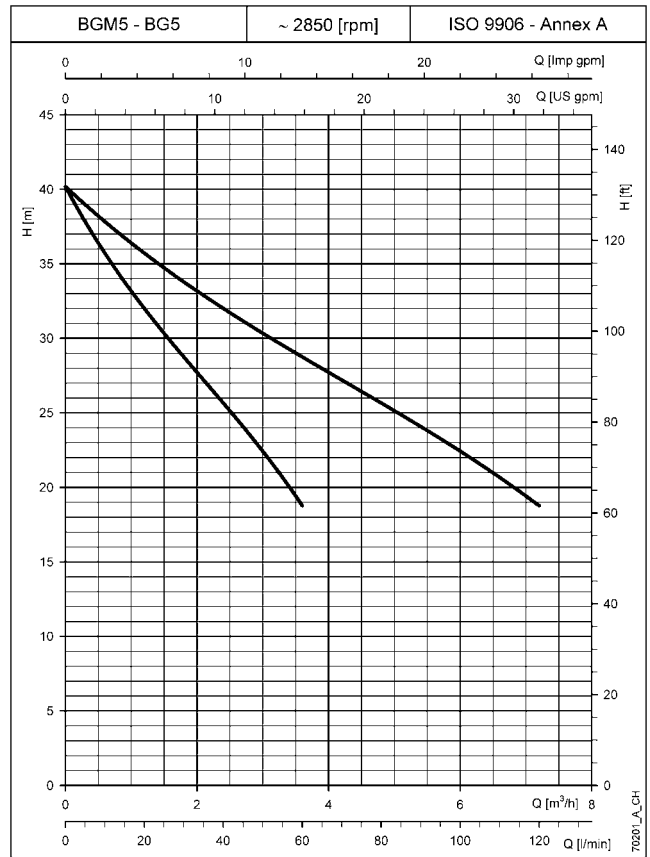
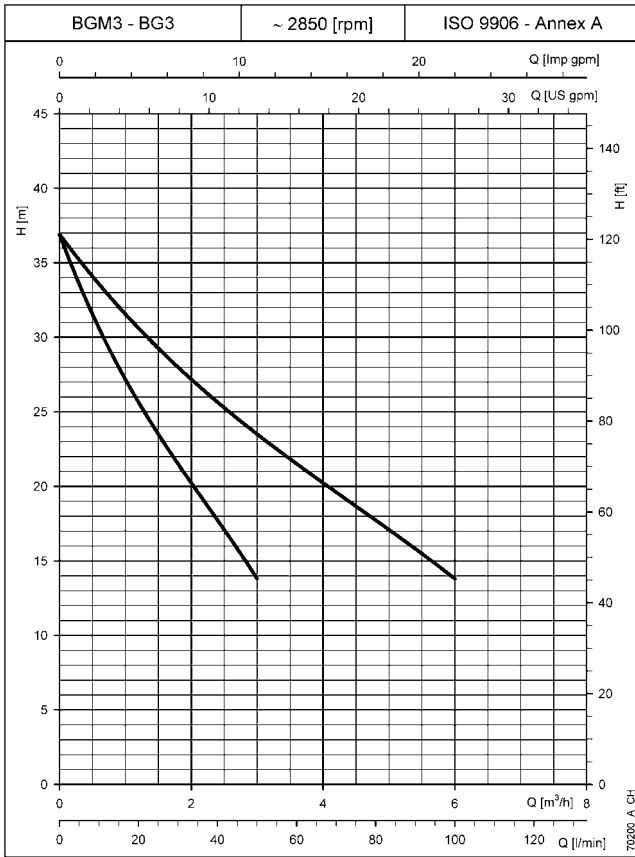

CURVES

The performance curves do not take into account flow resistance in the valves and piping.
The curves show the performance with one and two pumps running.
These performances are valid for liquids with density $\rho = 1.0 \text{ Kg/dm}^3$ and kinematic viscosity $\nu = 1 \text{ mm}^2/\text{s}$.

TWO-PUMP BOOSTER SETS OPERATING CHARACTERISTICS AT 50 Hz

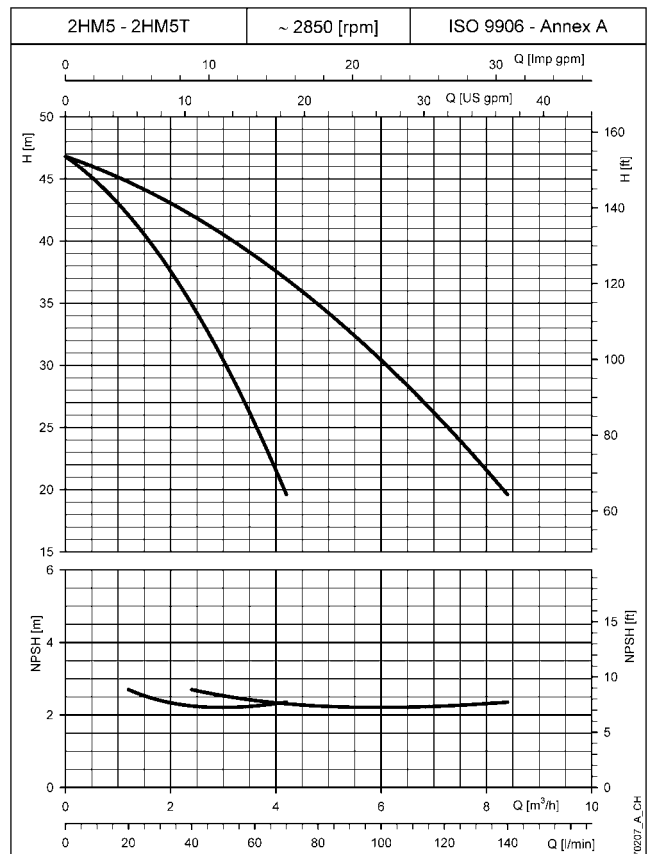
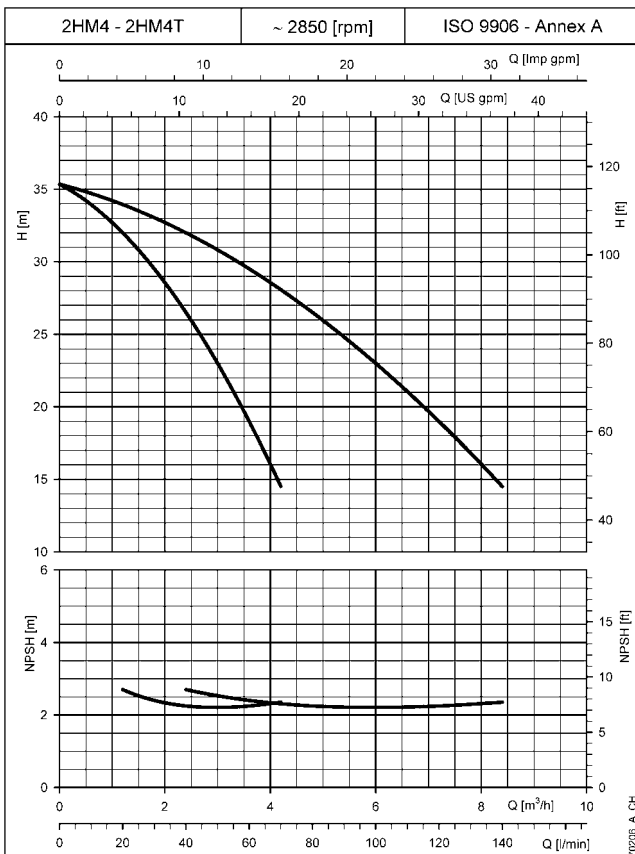
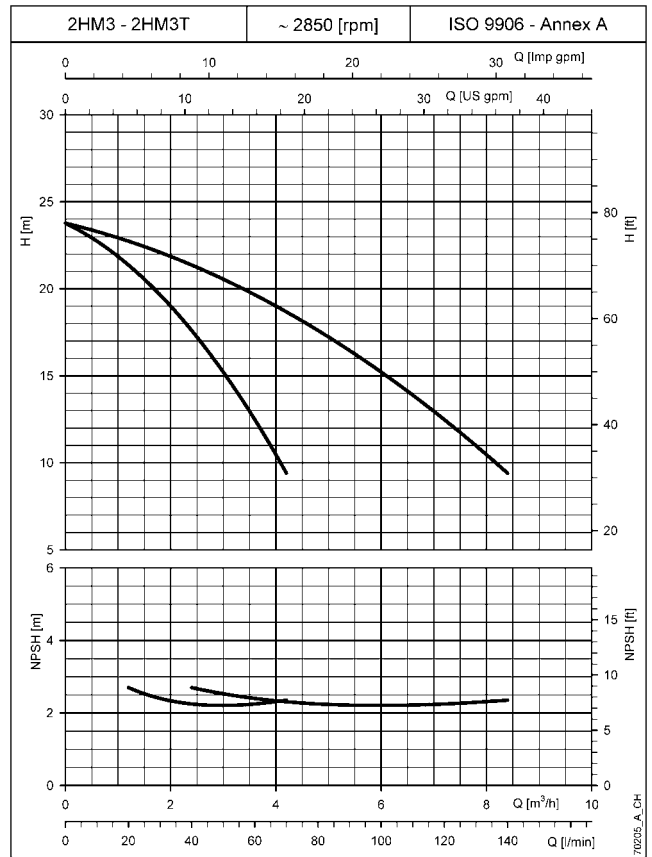
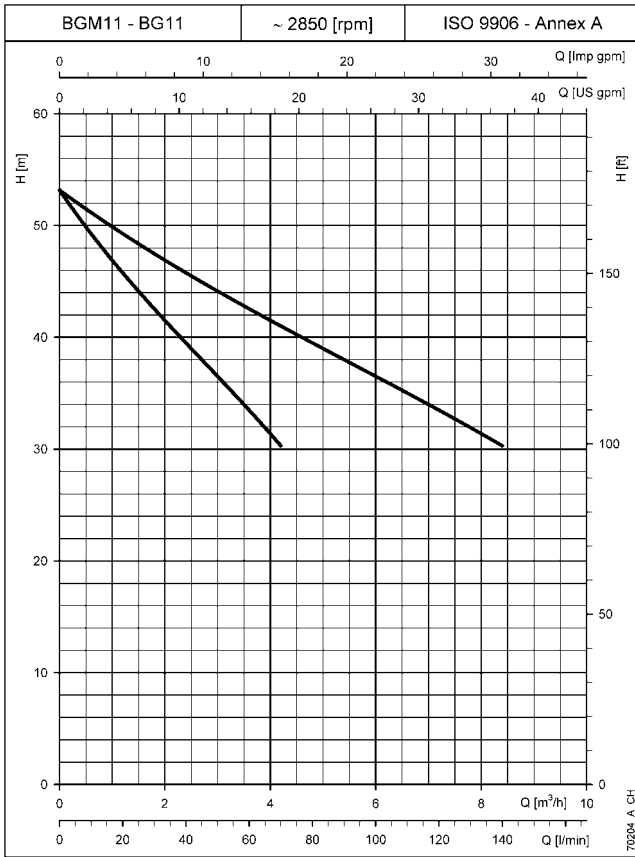

The performance curves do not take into account flow resistance in the valves and piping.
 The curves show the performance with one and two pumps running.
 These performances are valid for liquids with density $\rho = 1.0 \text{ Kg/dm}^3$ and kinematic viscosity $\nu = 1 \text{ mm}^2/\text{s}$.
 The declared NPSH values are laboratory values: for practical use we recommend increasing these values by 0,5 m.

CURVES

TWO-PUMP BOOSTER SETS OPERATING CHARACTERISTICS AT 50 Hz

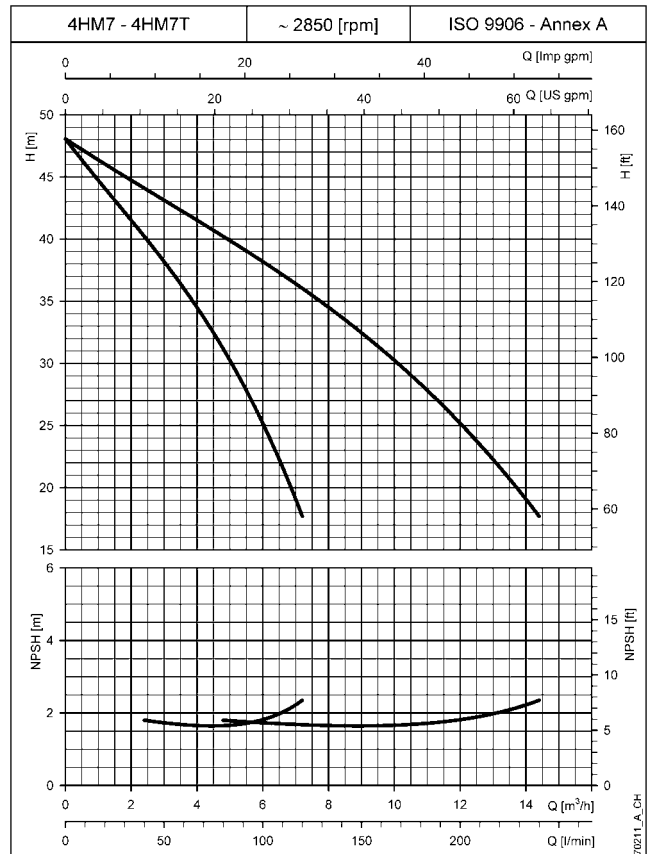
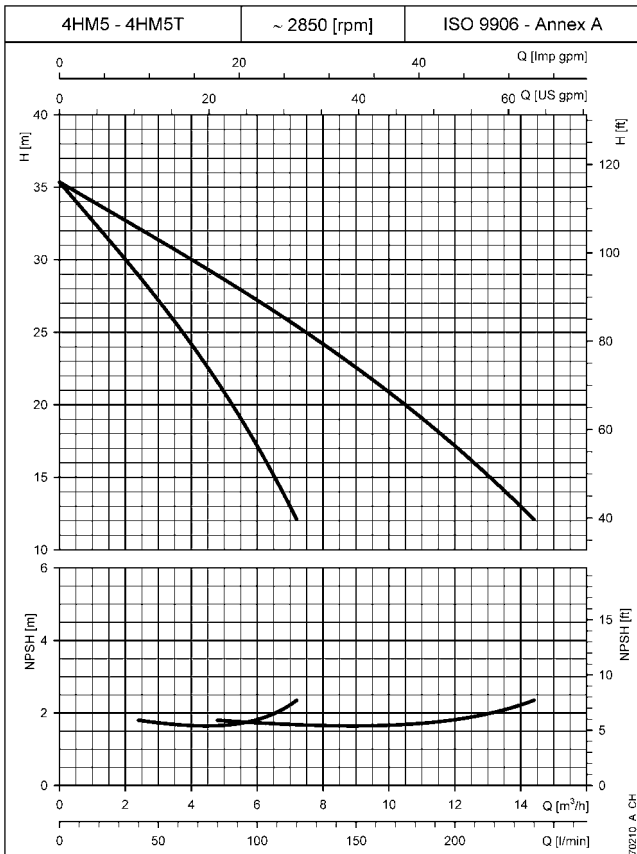
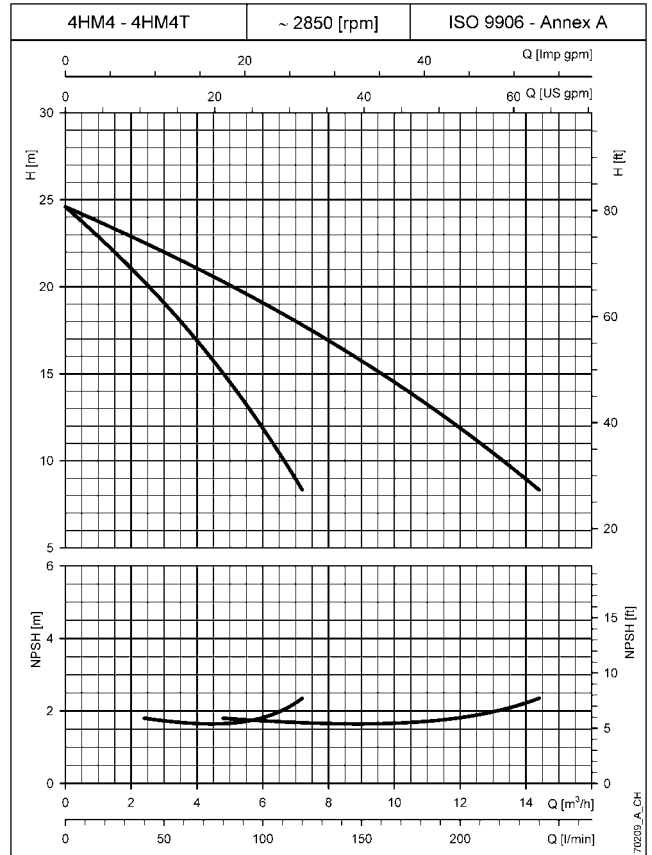
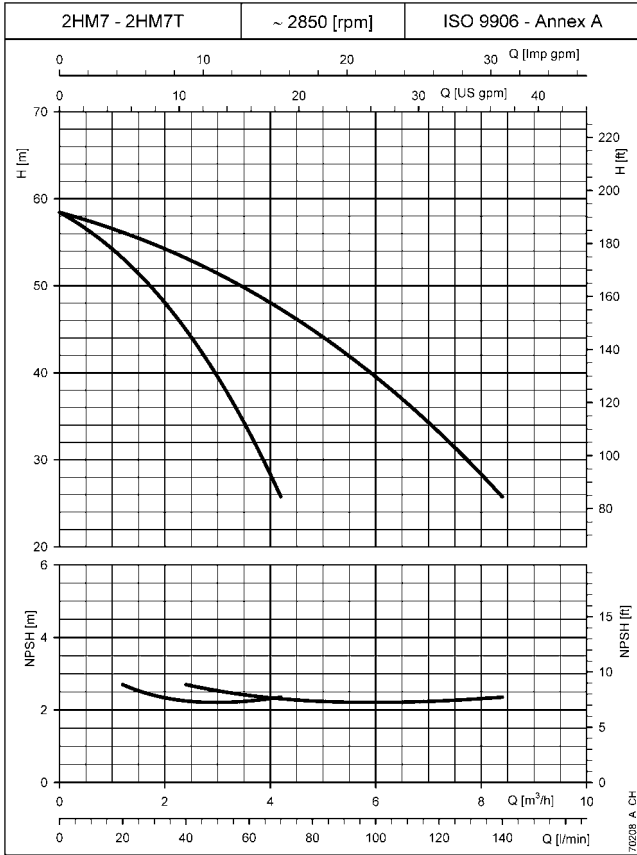

CURVES

The performance curves do not take into account flow resistance in the valves and piping.
 The curves show the performance with one and two pumps running.
 These performances are valid for liquids with density $\rho = 1.0 \text{ Kg/dm}^3$ and kinematic viscosity $\nu = 1 \text{ mm}^2/\text{s}$.
 The declared NPSH values are laboratory values: for practical use we recommend increasing these values by 0,5 m.

**TWO-PUMP BOOSTER SETS
OPERATING CHARACTERISTICS AT 50 Hz**

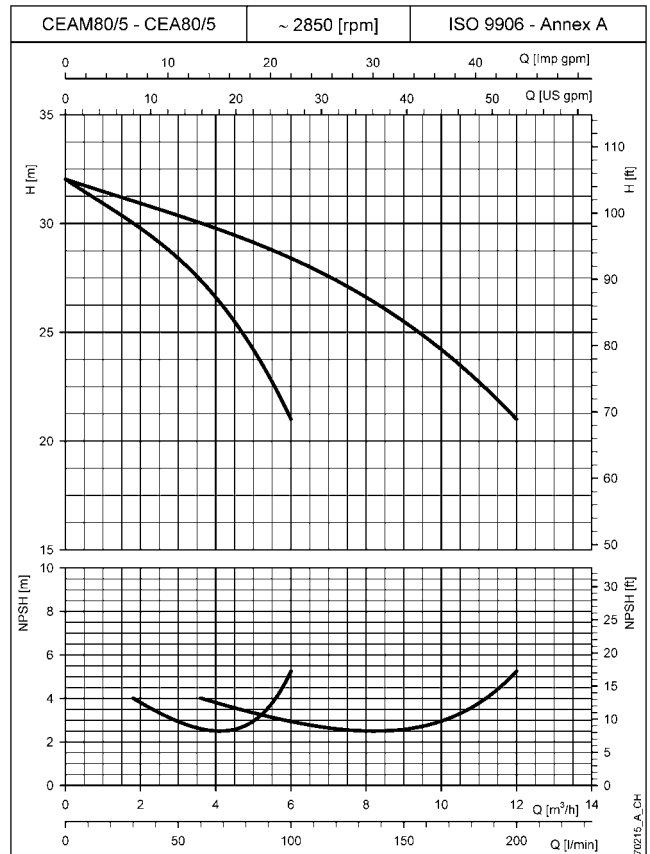
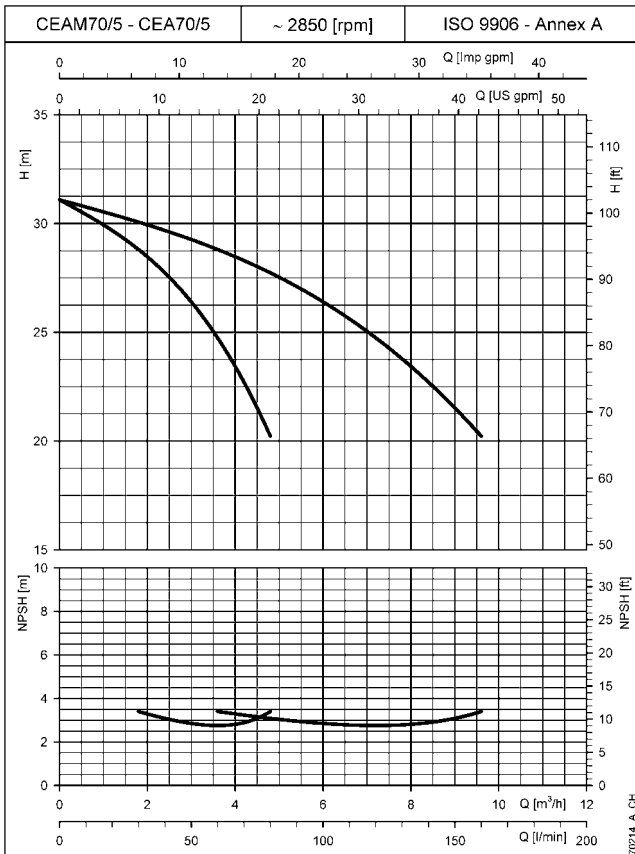
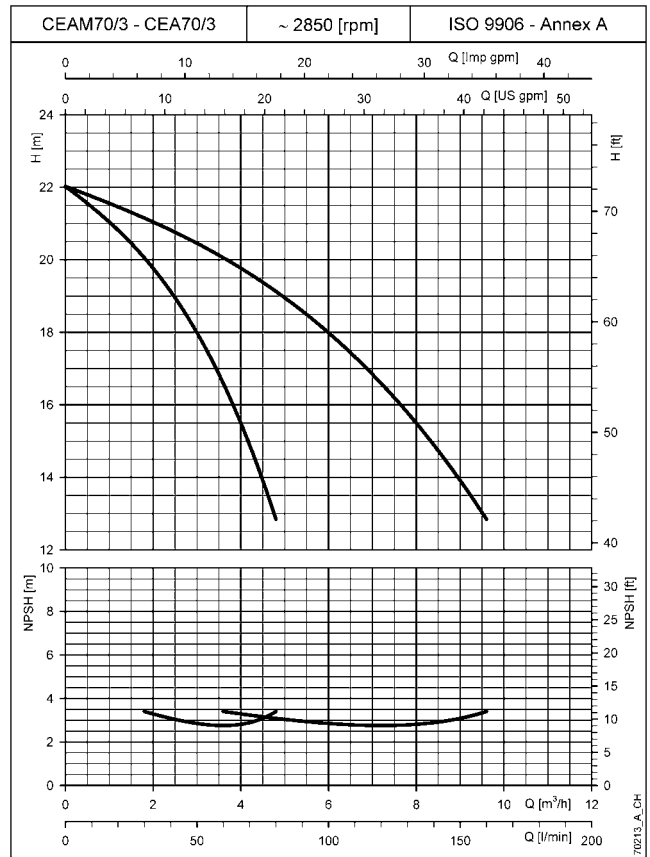
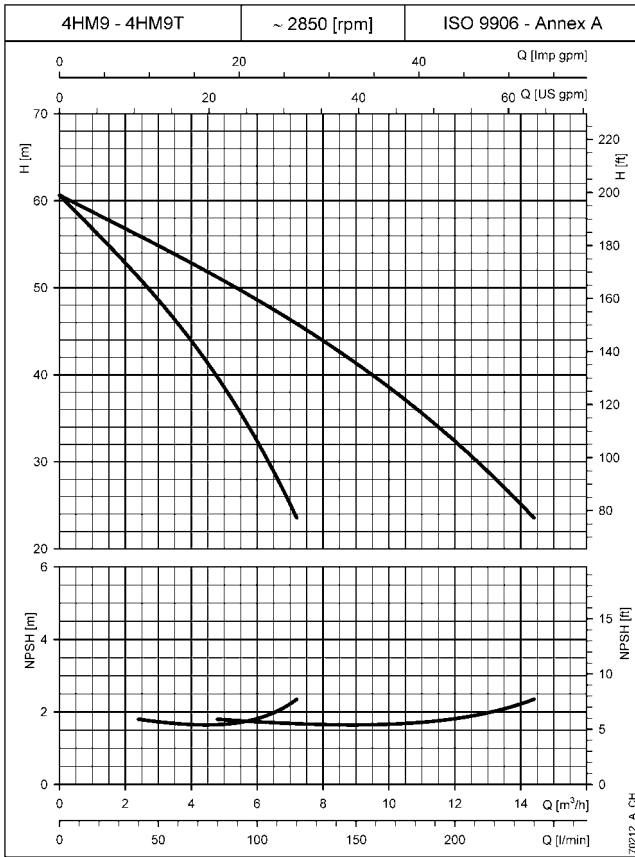

The performance curves do not take into account flow resistance in the valves and piping.
The curves show the performance with one and two pumps running.
These performances are valid for liquids with density $\rho = 1.0 \text{ Kg/dm}^3$ and kinematic viscosity $\nu = 1 \text{ mm}^2/\text{s}$.
The declared NPSH values are laboratory values: for practical use we recommend increasing these values by 0,5 m.

CURVES

TWO-PUMP BOOSTER SETS OPERATING CHARACTERISTICS AT 50 Hz

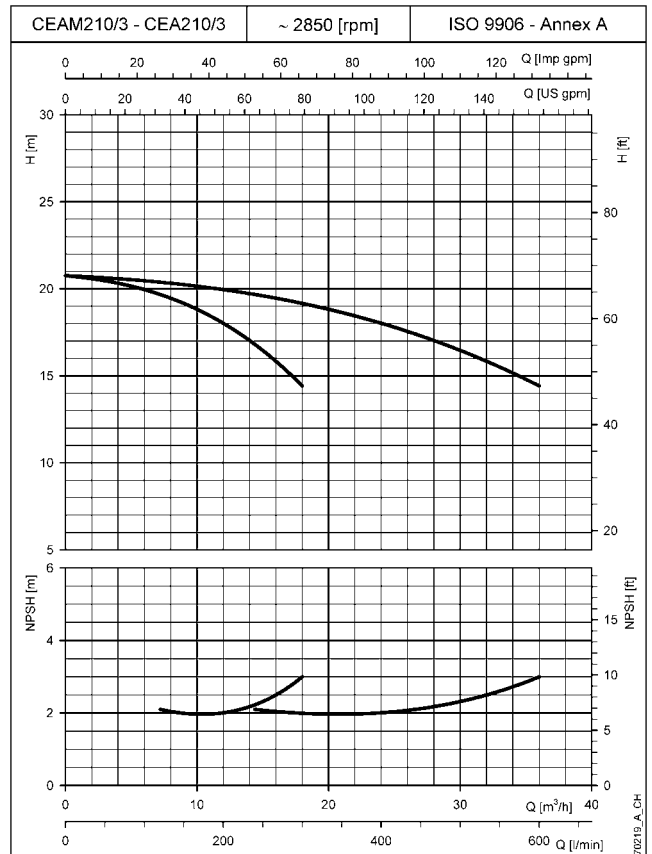
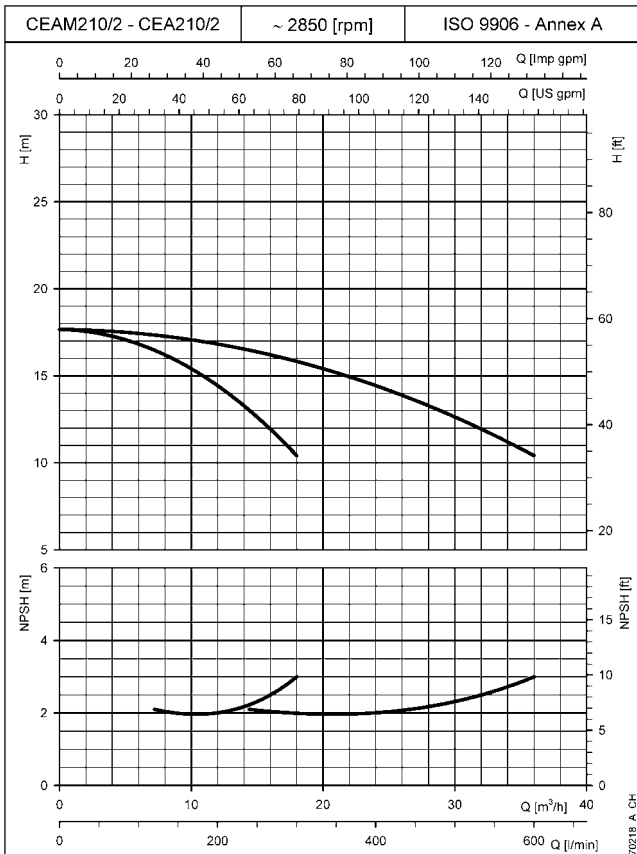
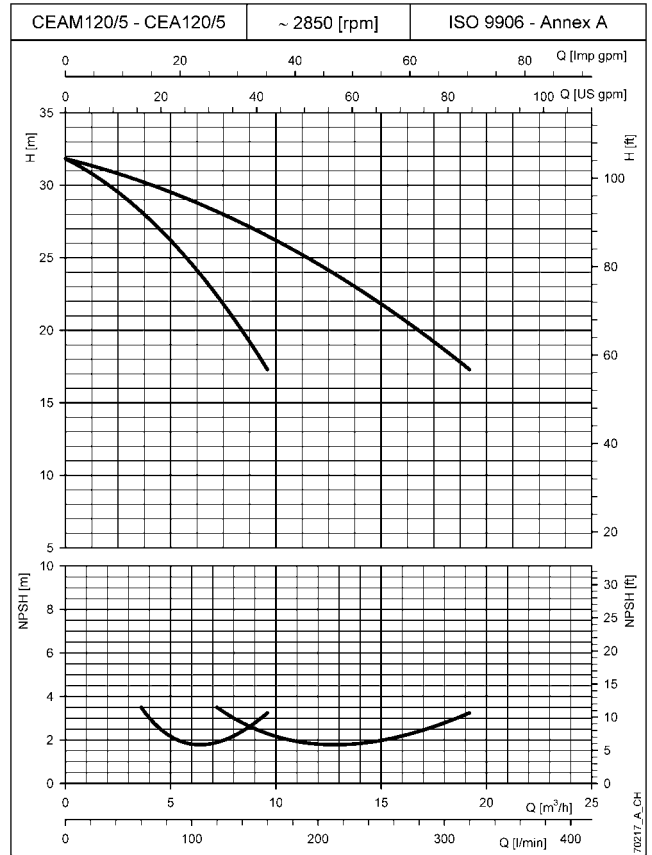
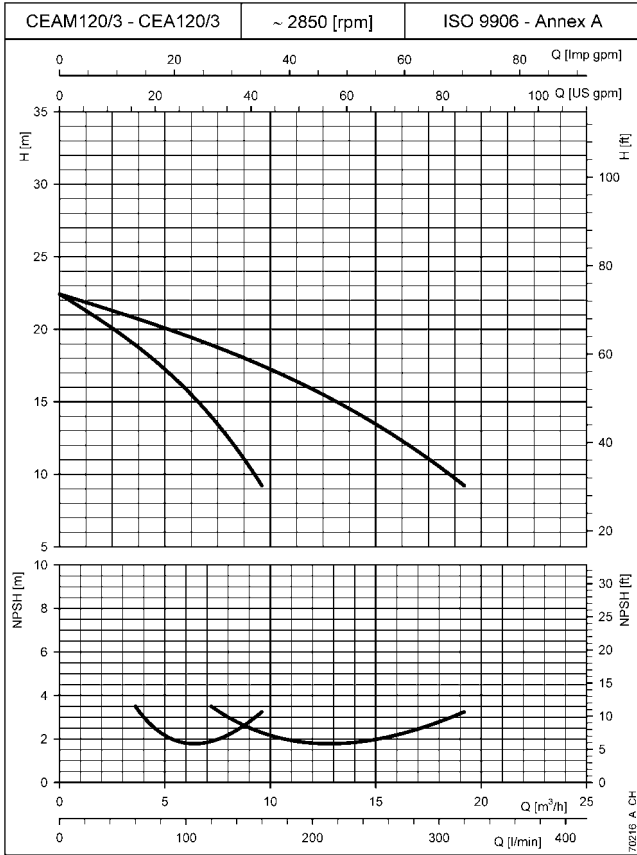

CURVES

The performance curves do not take into account flow resistance in the valves and piping.
 The curves show the performance with one and two pumps running.
 These performances are valid for liquids with density $\rho = 1.0 \text{ Kg/dm}^3$ and kinematic viscosity $\nu = 1 \text{ mm}^2/\text{s}$.
 The declared NPSH values are laboratory values: for practical use we recommend increasing these values by 0,5 m.

TWO-PUMP BOOSTER SETS OPERATING CHARACTERISTICS AT 50 Hz

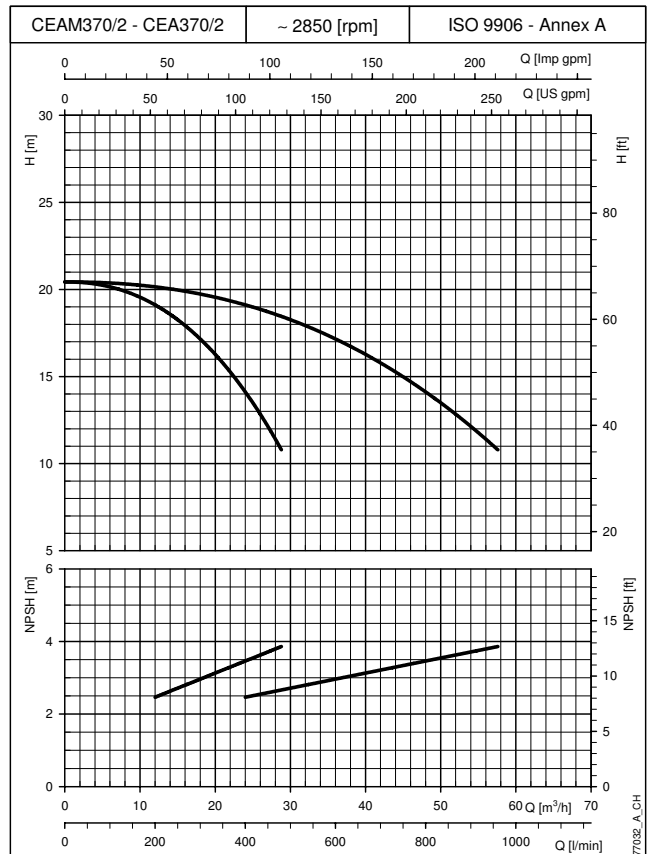
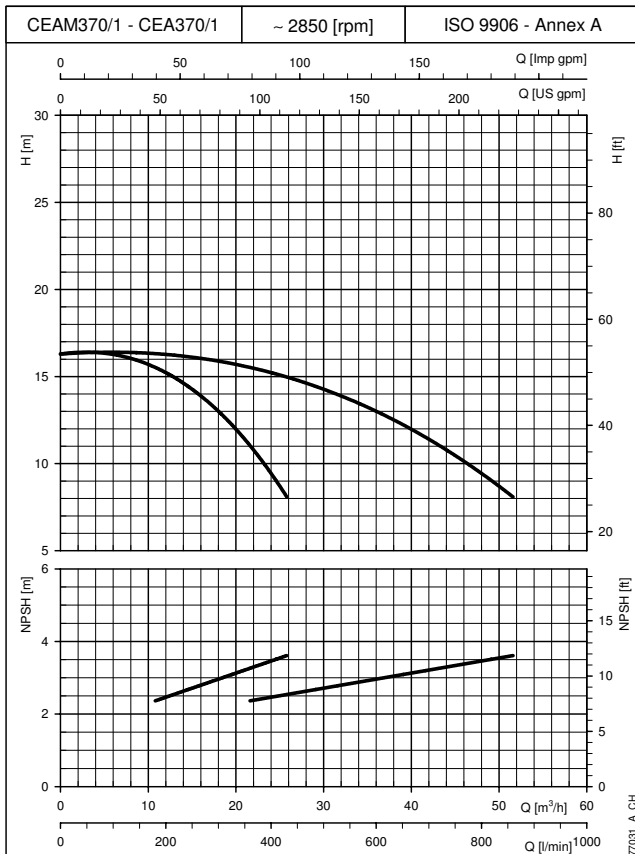
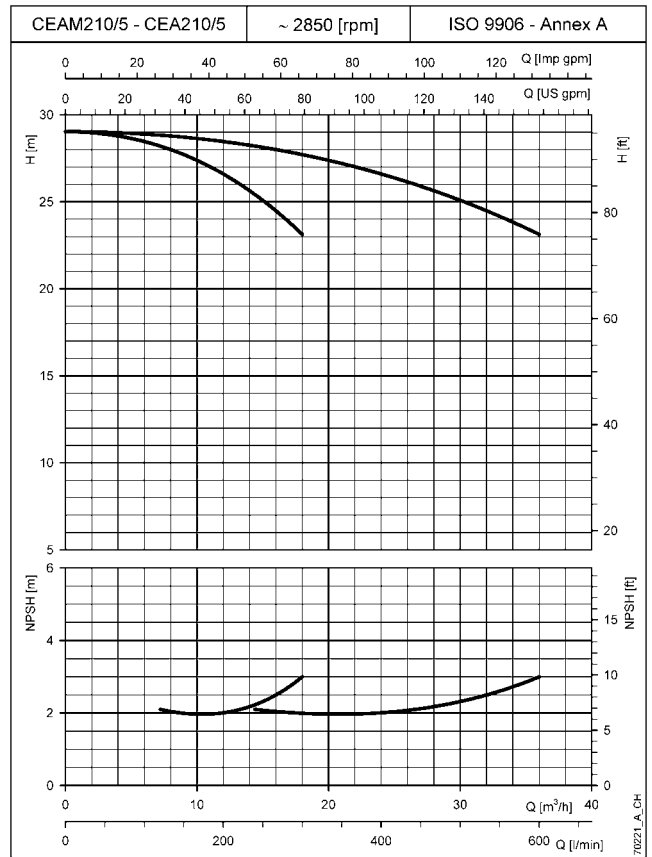
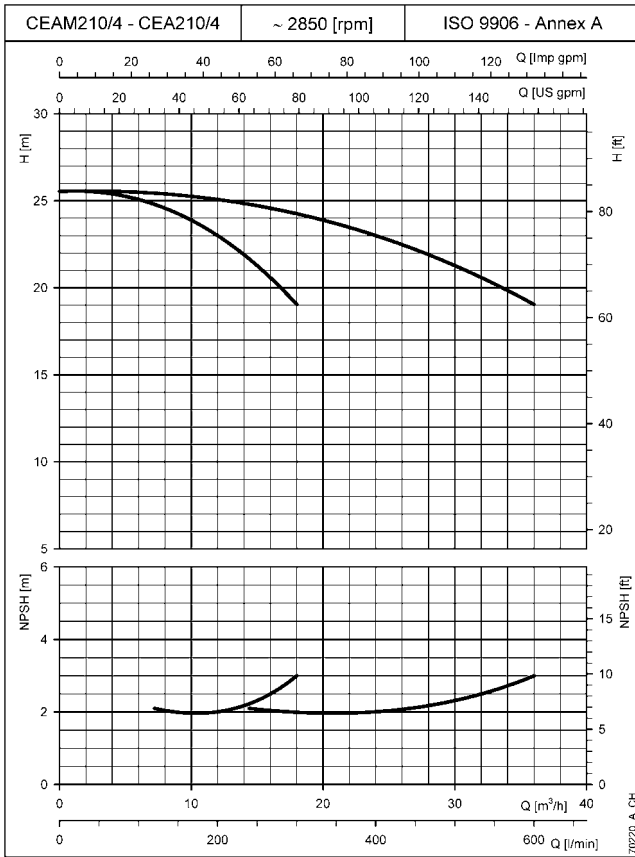

The performance curves do not take into account flow resistance in the valves and piping.
 The curves show the performance with one and two pumps running.
 These performances are valid for liquids with density $\rho = 1.0 \text{ Kg/dm}^3$ and kinematic viscosity $\nu = 1 \text{ mm}^2/\text{s}$.
 The declared NPSH values are laboratory values: for practical use we recommend increasing these values by 0,5 m.

CURVES

**TWO-PUMP BOOSTER SETS
OPERATING CHARACTERISTICS AT 50 Hz**

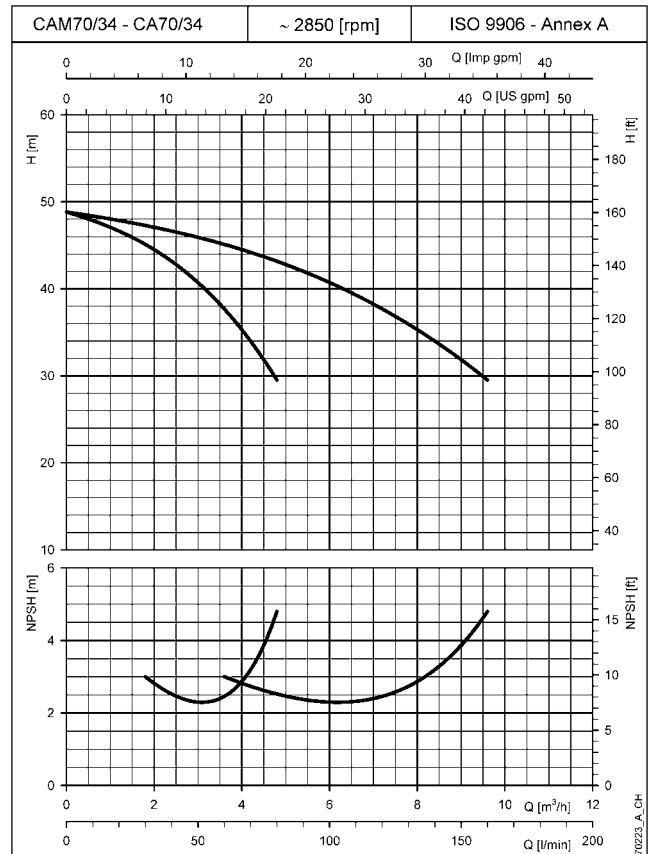
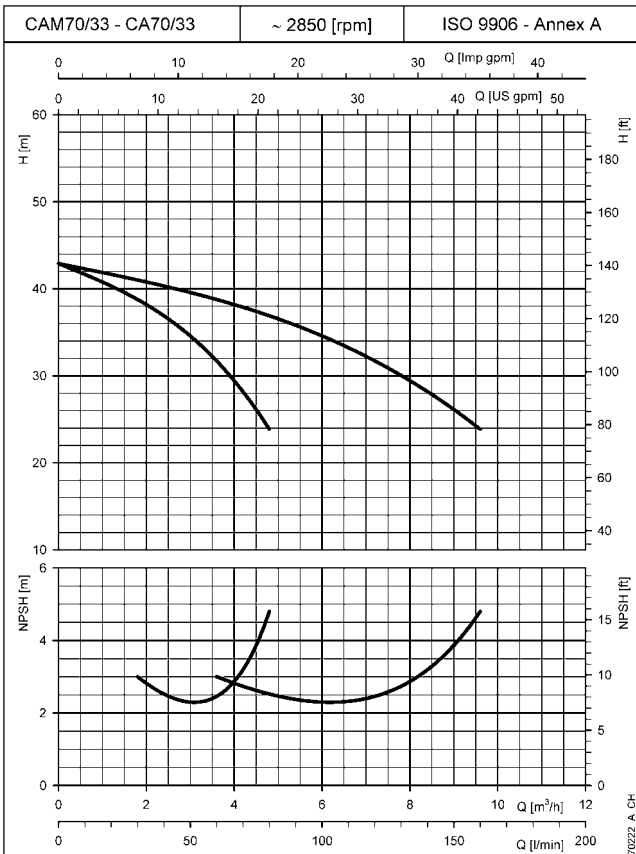
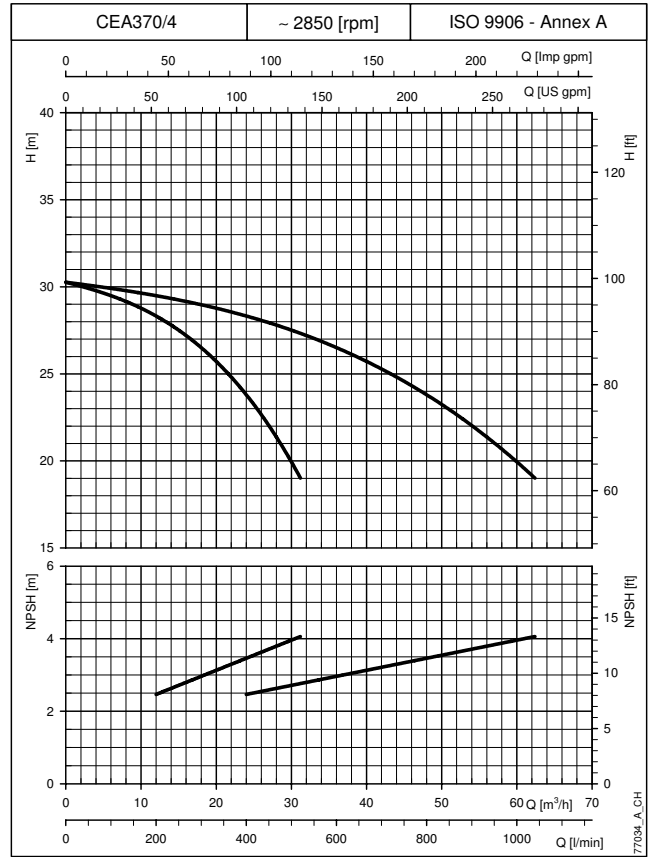
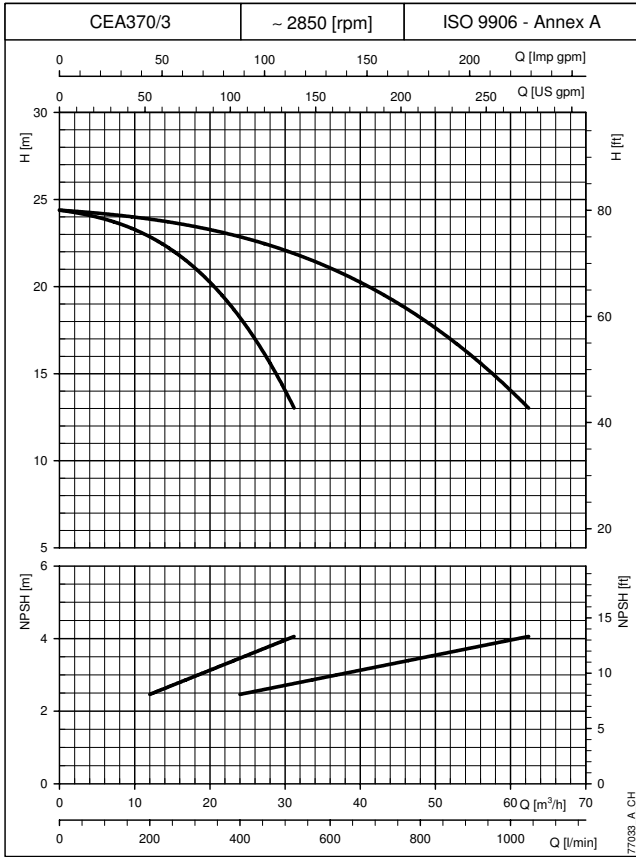

CURVES

The performance curves do not take into account flow resistance in the valves and piping.
The curves show the performance with one and two pumps running.
These performances are valid for liquids with density $\rho = 1.0 \text{ Kg/dm}^3$ and kinematic viscosity $\nu = 1 \text{ mm}^2/\text{s}$.
The declared NPSH values are laboratory values: for practical use we recommend increasing these values by 0,5 m.

TWO-PUMP BOOSTER SETS OPERATING CHARACTERISTICS AT 50 Hz

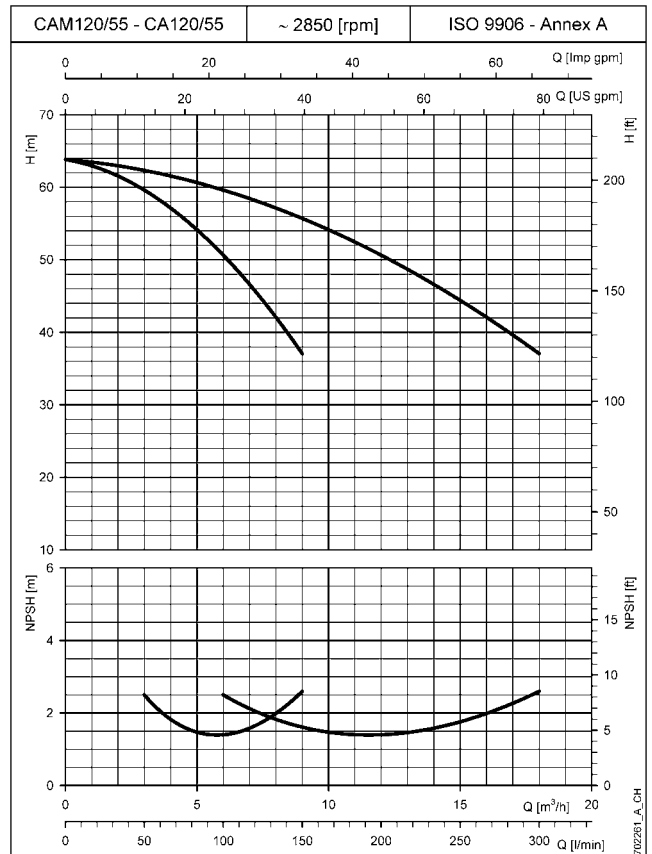
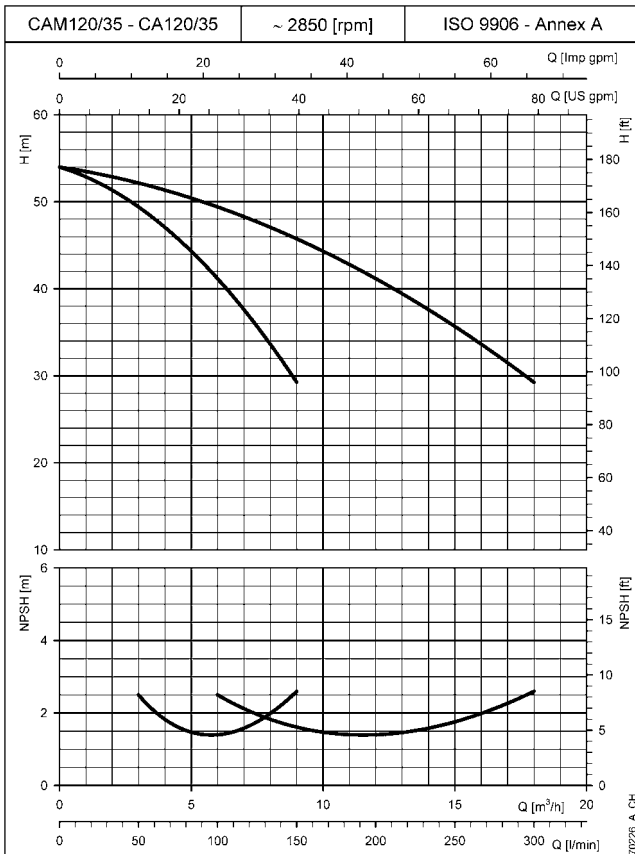
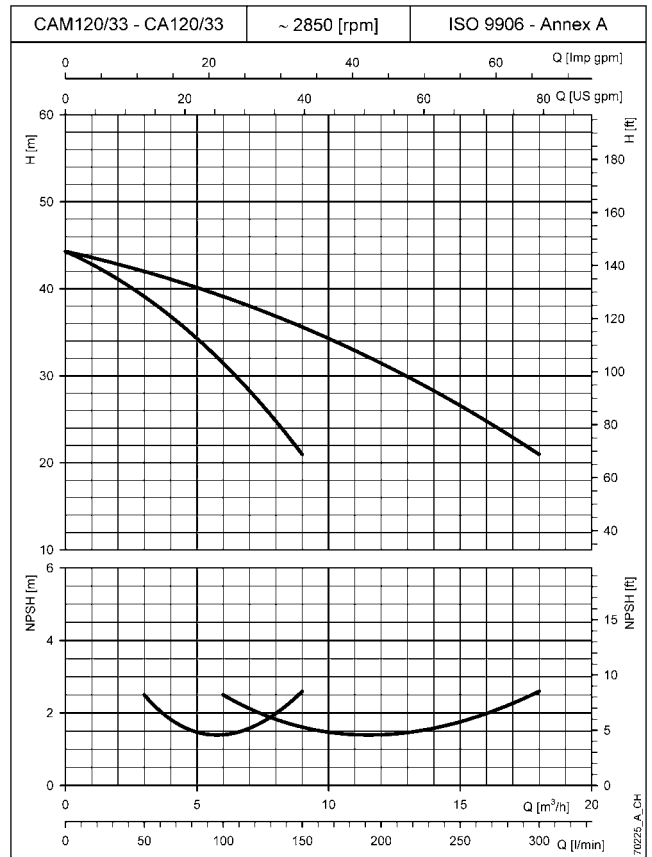
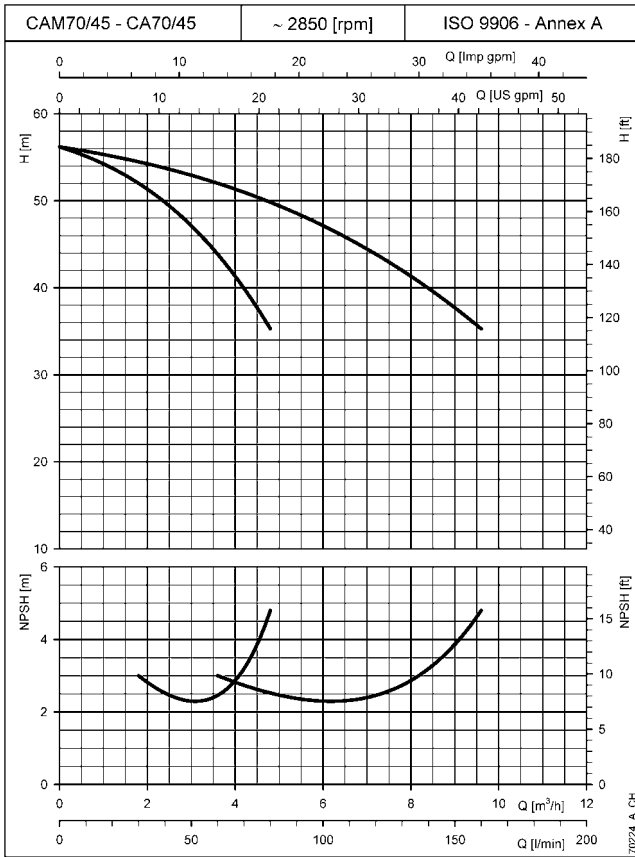

The performance curves do not take into account flow resistance in the valves and piping.
 The curves show the performance with one and two pumps running.
 These performances are valid for liquids with density $\rho = 1.0 \text{ Kg/dm}^3$ and kinematic viscosity $\nu = 1 \text{ mm}^2/\text{s}$.
 The declared NPSH values are laboratory values: for practical use we recommend increasing these values by 0,5 m.

CURVES

TWO-PUMP BOOSTER SETS OPERATING CHARACTERISTICS AT 50 Hz

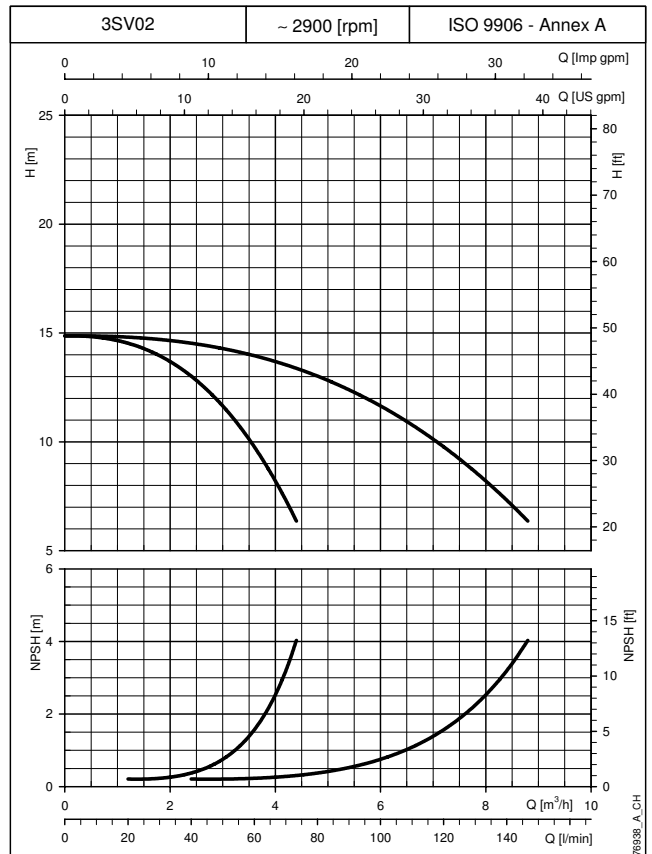
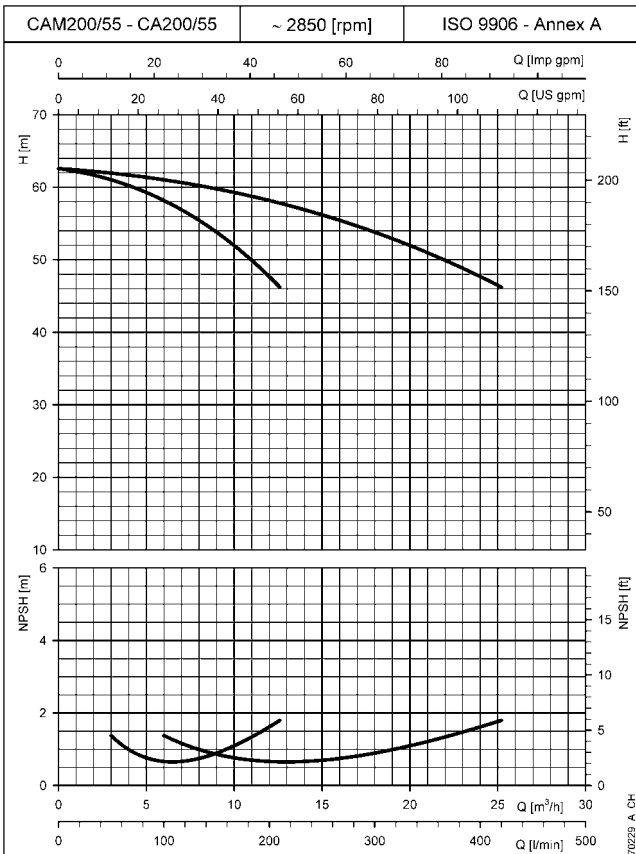
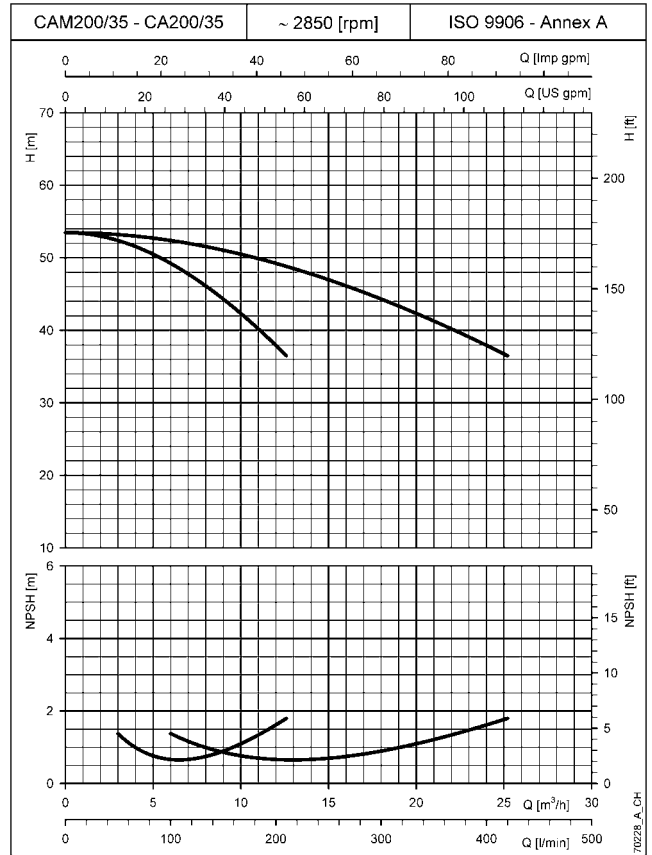
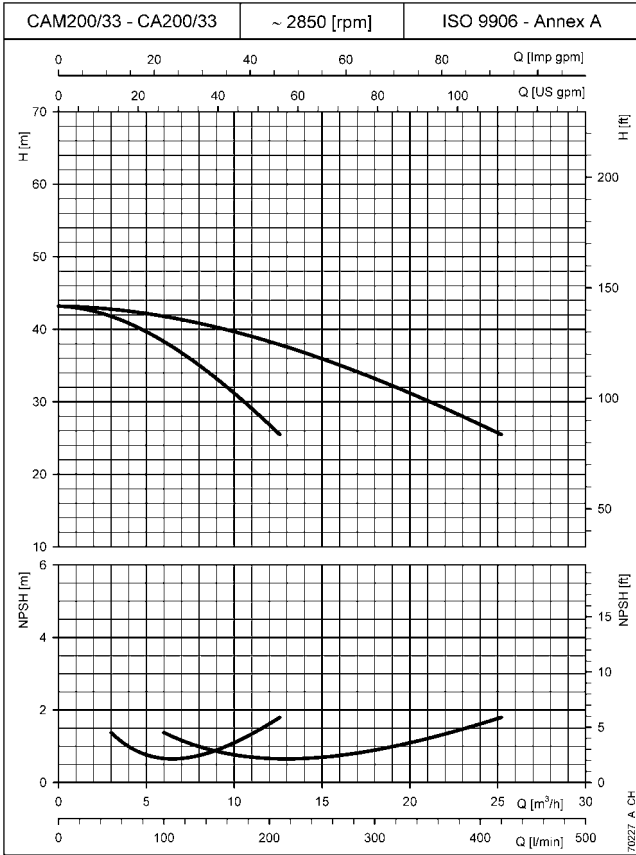

CURVES

The performance curves do not take into account flow resistance in the valves and piping.
 The curves show the performance with one and two pumps running.
 These performances are valid for liquids with density $\rho = 1.0 \text{ Kg/dm}^3$ and kinematic viscosity $\nu = 1 \text{ mm}^2/\text{s}$.
 The declared NPSH values are laboratory values: for practical use we recommend increasing these values by 0,5 m.

TWO-PUMP BOOSTER SETS OPERATING CHARACTERISTICS AT 50 Hz

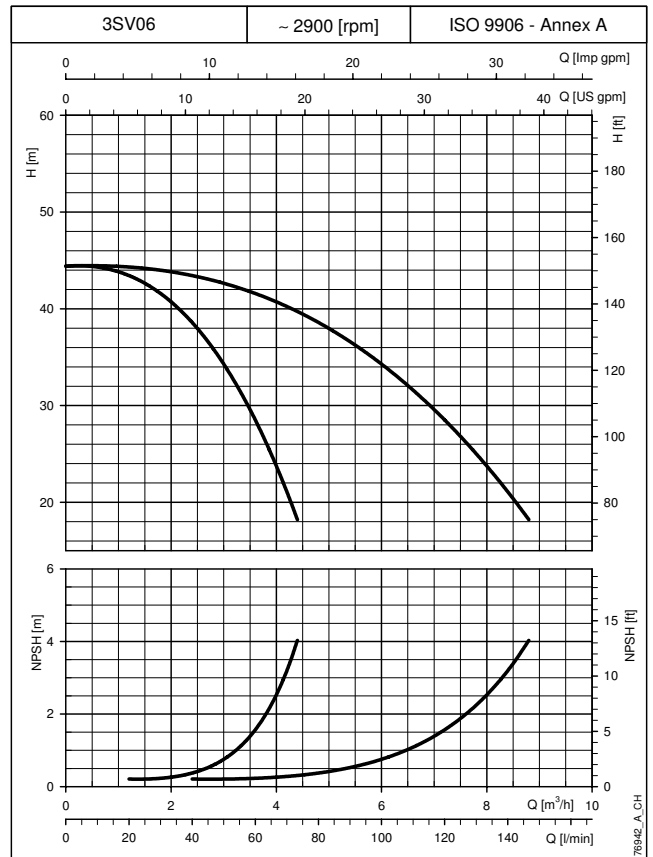
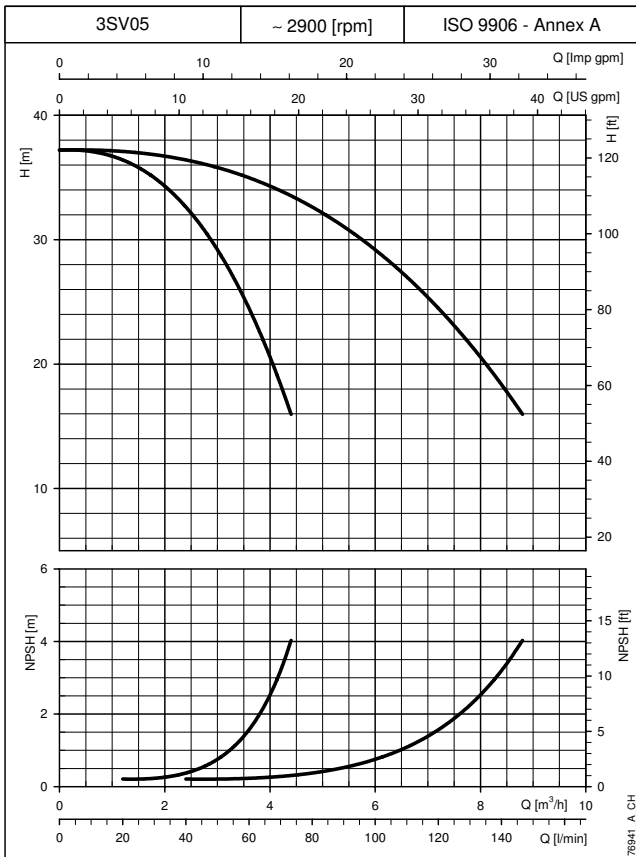
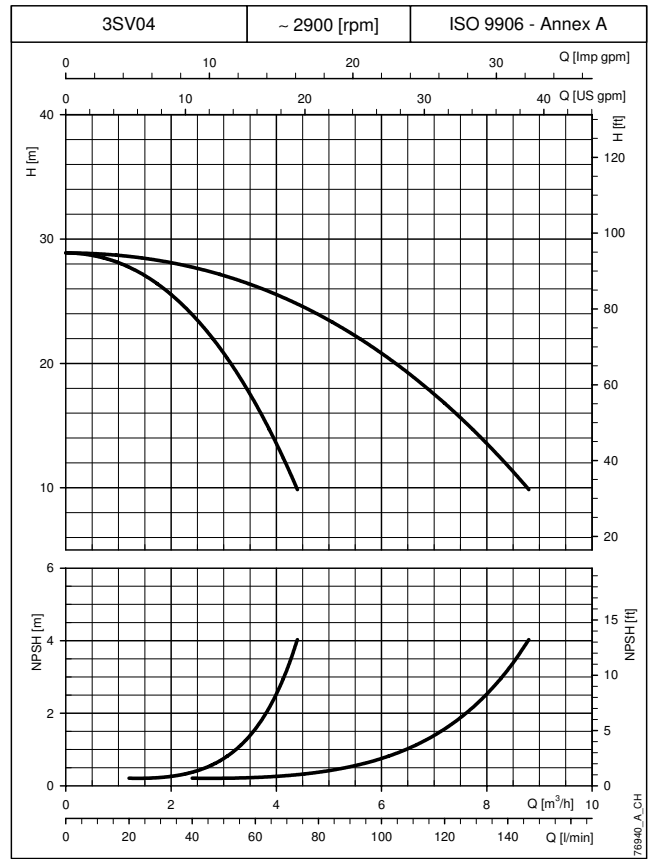
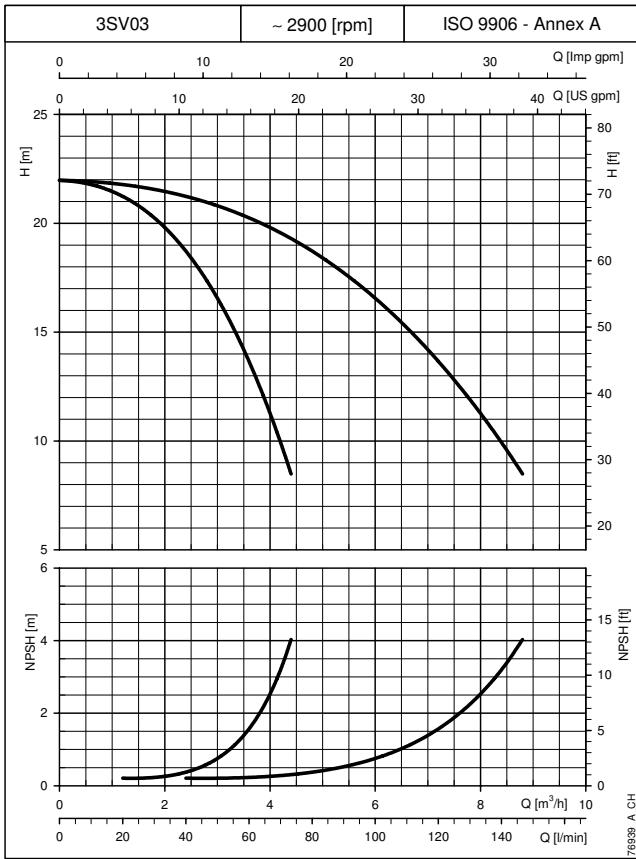

The performance curves do not take into account flow resistance in the valves and piping.
 The curves show the performance with one and two pumps running.
 These performances are valid for liquids with density $\rho = 1.0 \text{ Kg/dm}^3$ and kinematic viscosity $\nu = 1 \text{ mm}^2/\text{s}$.
 The declared NPSH values are laboratory values: for practical use we recommend increasing these values by 0,5 m.

CURVES

TWO-PUMP BOOSTER SETS OPERATING CHARACTERISTICS AT 50 Hz

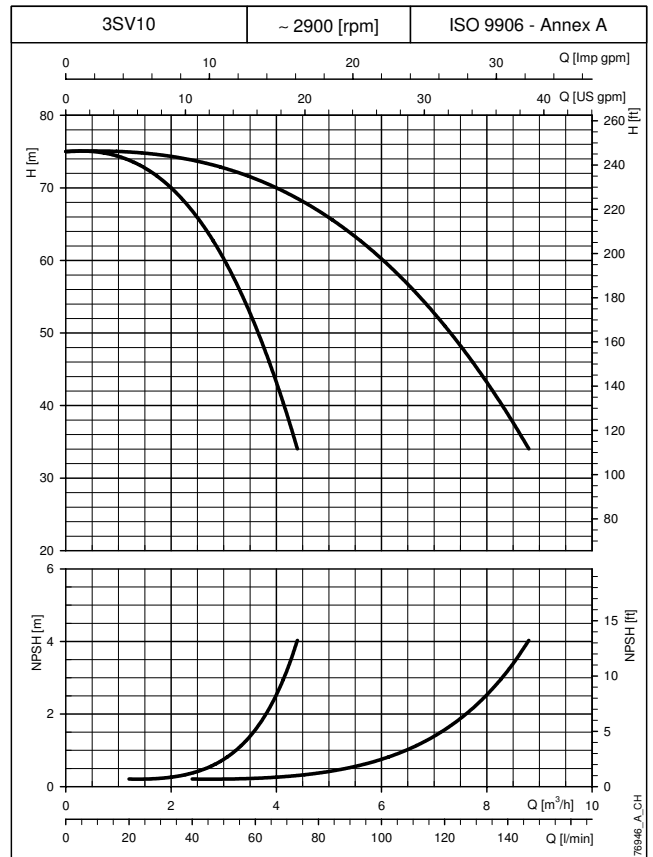
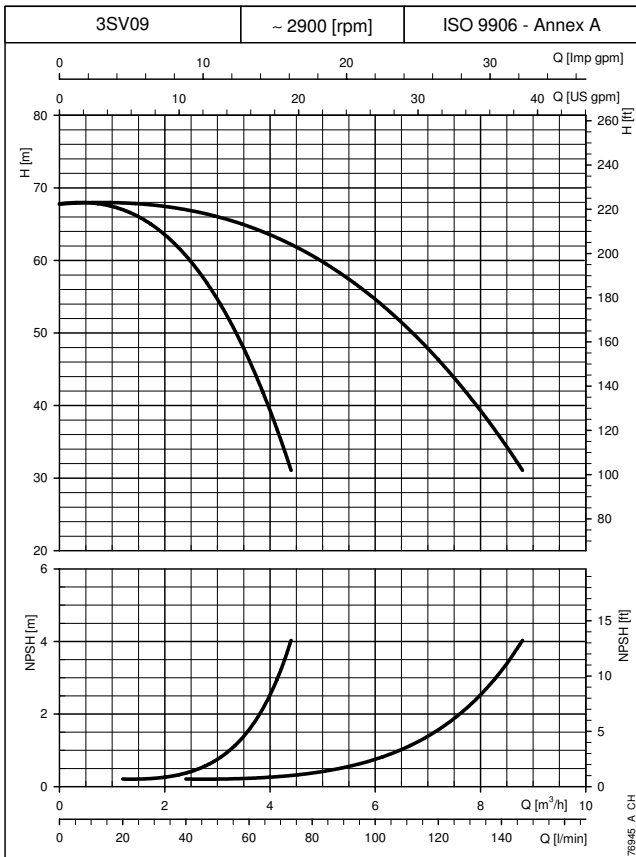
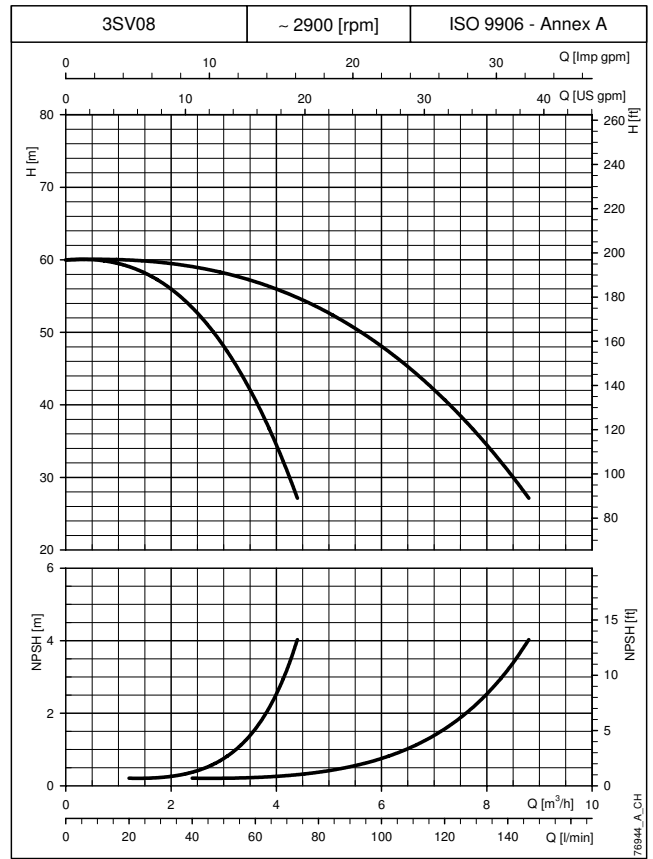
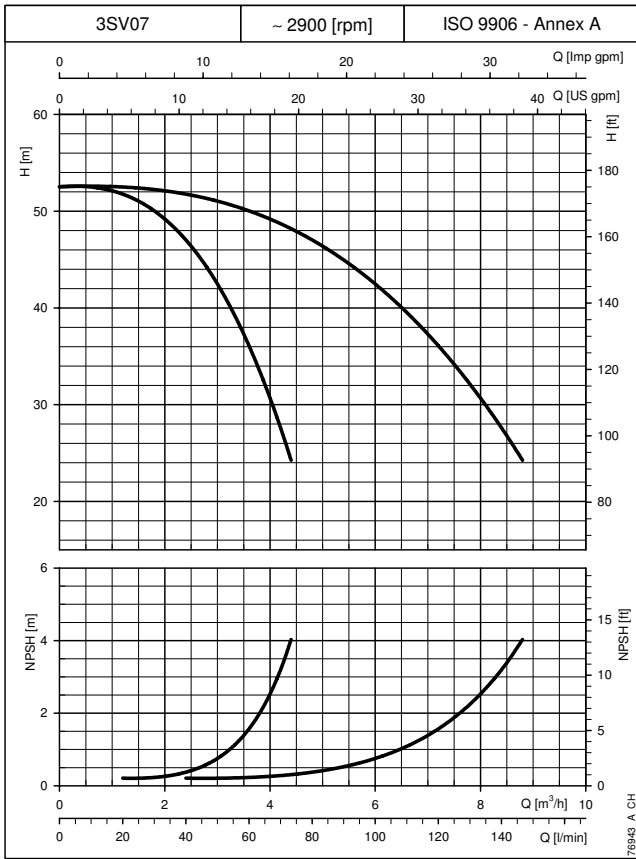

CURVES

The performance curves do not take into account flow resistance in the valves and piping.
 The curves show the performance with one and two pumps running.
 These performances are valid for liquids with density $\rho = 1.0 \text{ Kg/dm}^3$ and kinematic viscosity $\nu = 1 \text{ mm}^2/\text{s}$.
 The declared NPSH values are laboratory values: for practical use we recommend increasing these values by 0,5 m.

**TWO-PUMP BOOSTER SETS
OPERATING CHARACTERISTICS AT 50 Hz**

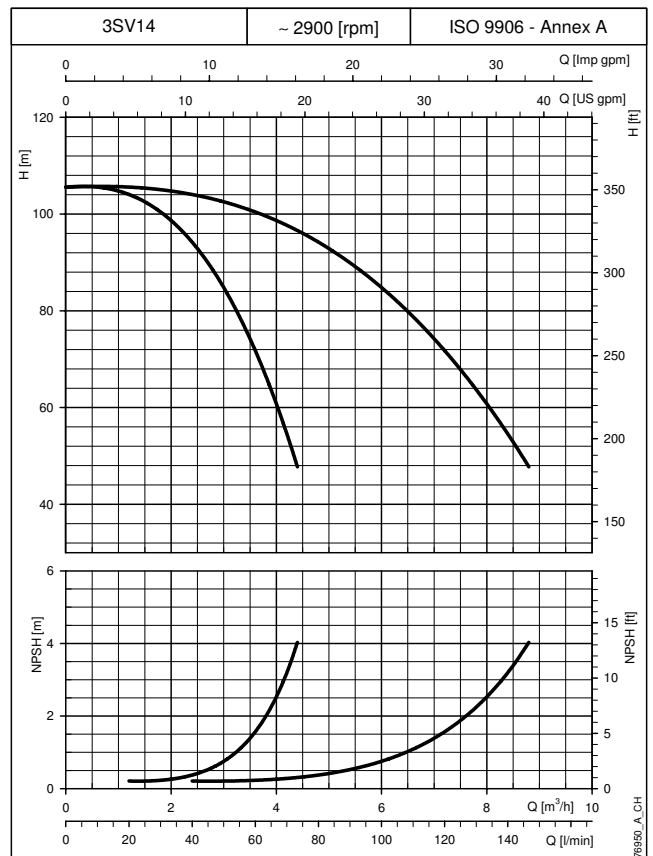
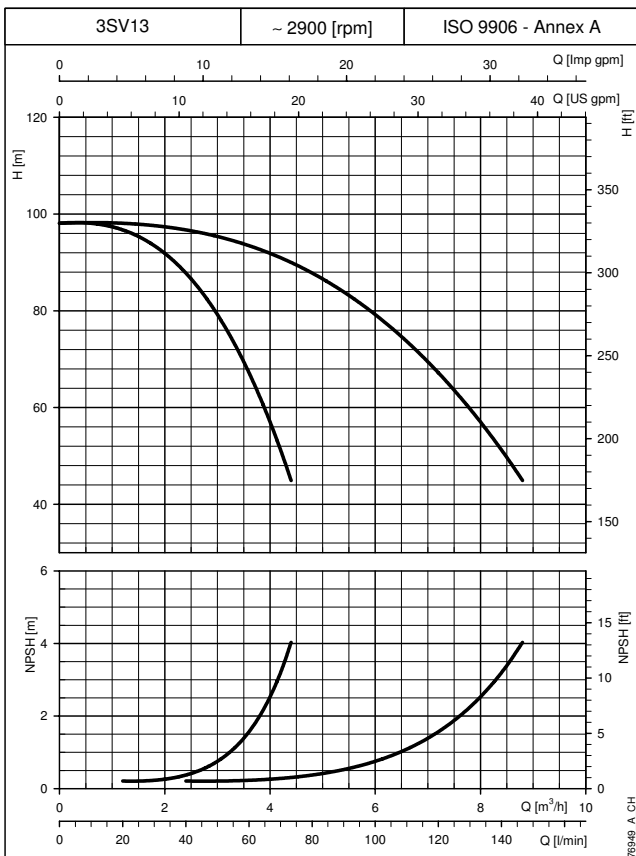
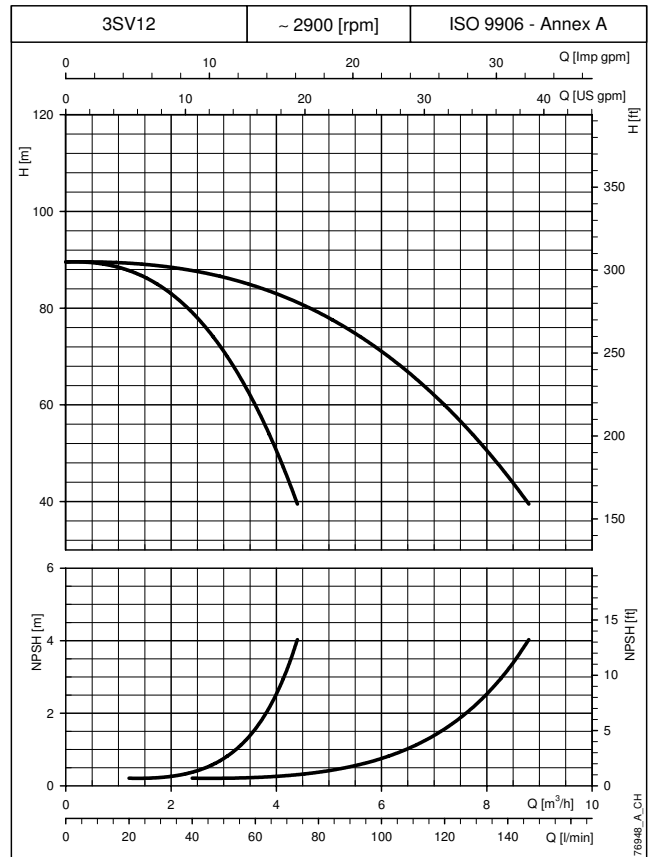
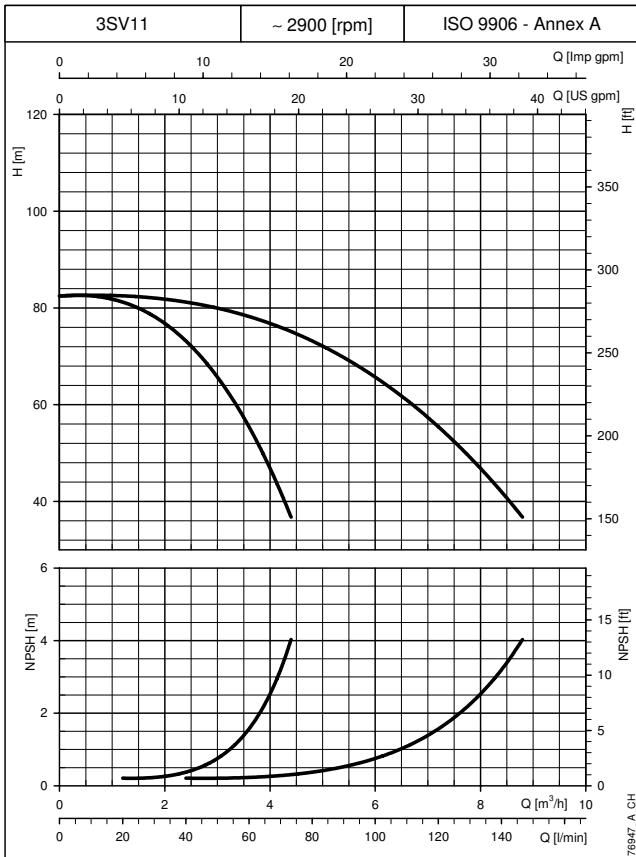

The performance curves do not take into account flow resistance in the valves and piping.
 The curves show the performance with one and two pumps running.
 These performances are valid for liquids with density $\rho = 1.0 \text{ Kg/dm}^3$ and kinematic viscosity $\nu = 1 \text{ mm}^2/\text{s}$.
 The declared NPSH values are laboratory values: for practical use we recommend increasing these values by 0,5 m.

CURVES

TWO-PUMP BOOSTER SETS OPERATING CHARACTERISTICS AT 50 Hz

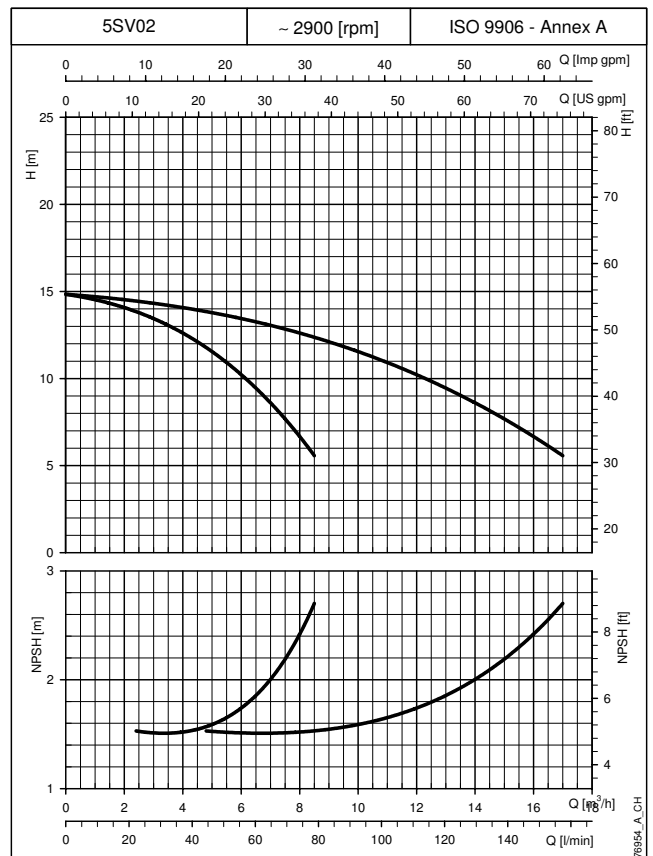
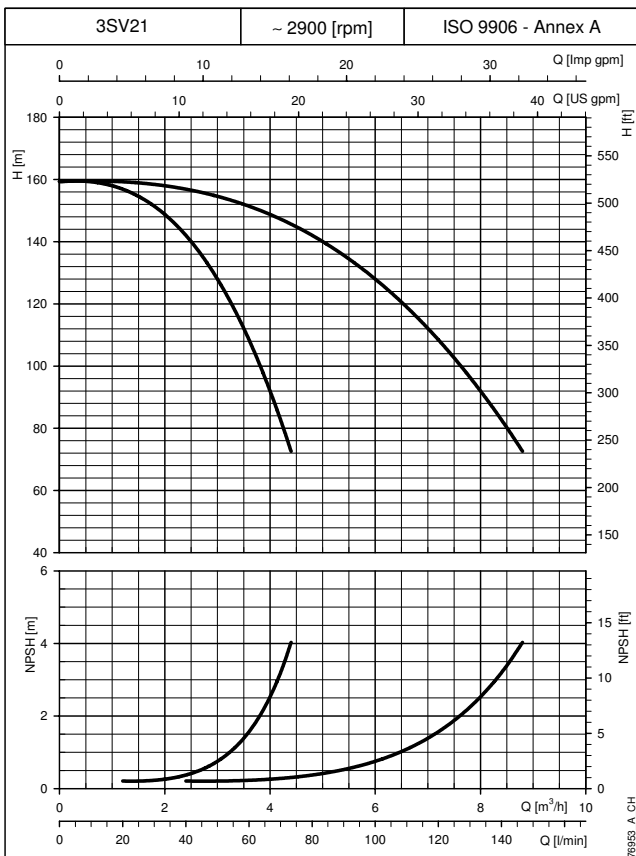
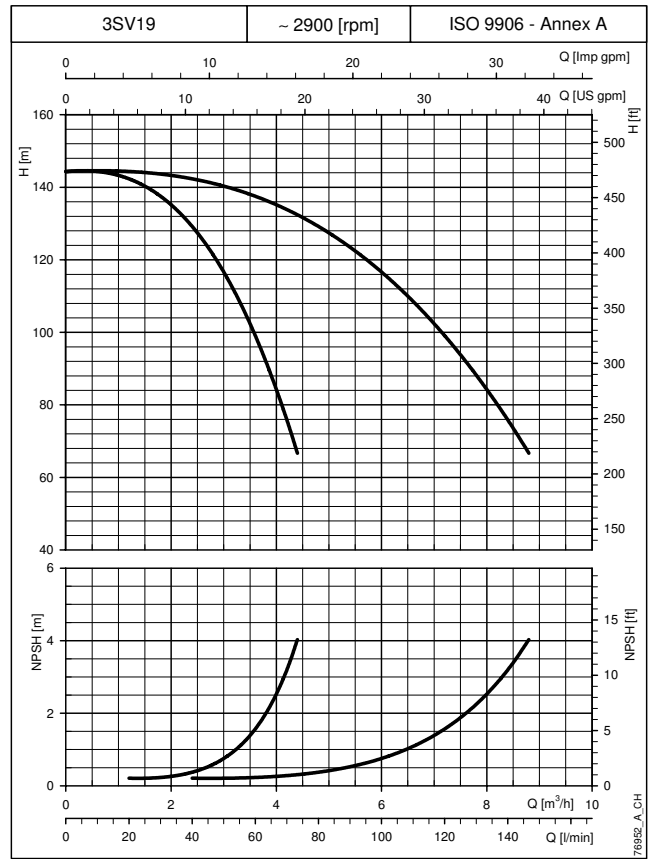
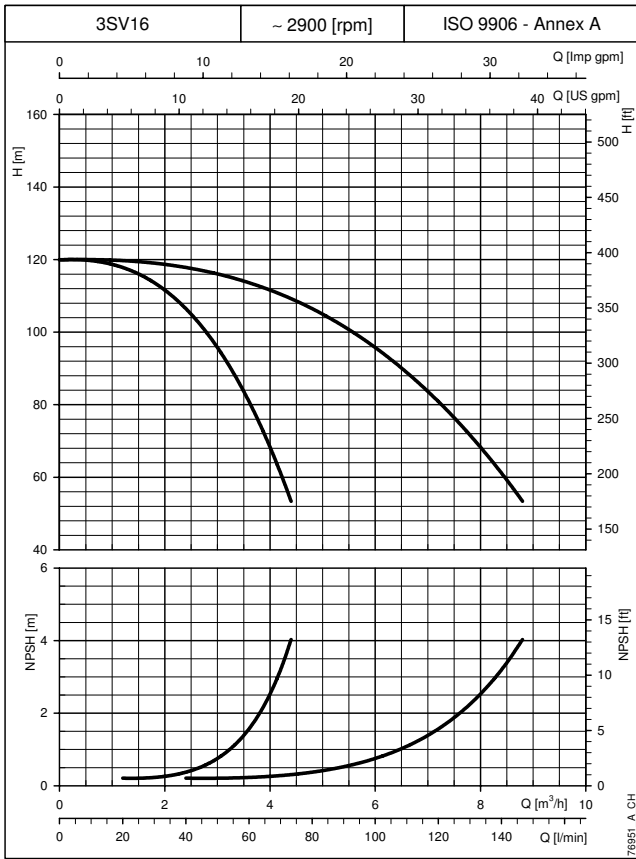

CURVES

The performance curves do not take into account flow resistance in the valves and piping.
 The curves show the performance with one and two pumps running.
 These performances are valid for liquids with density $\rho = 1.0 \text{ Kg/dm}^3$ and kinematic viscosity $\nu = 1 \text{ mm}^2/\text{s}$.
 The declared NPSH values are laboratory values: for practical use we recommend increasing these values by 0,5 m.

TWO-PUMP BOOSTER SETS OPERATING CHARACTERISTICS AT 50 Hz

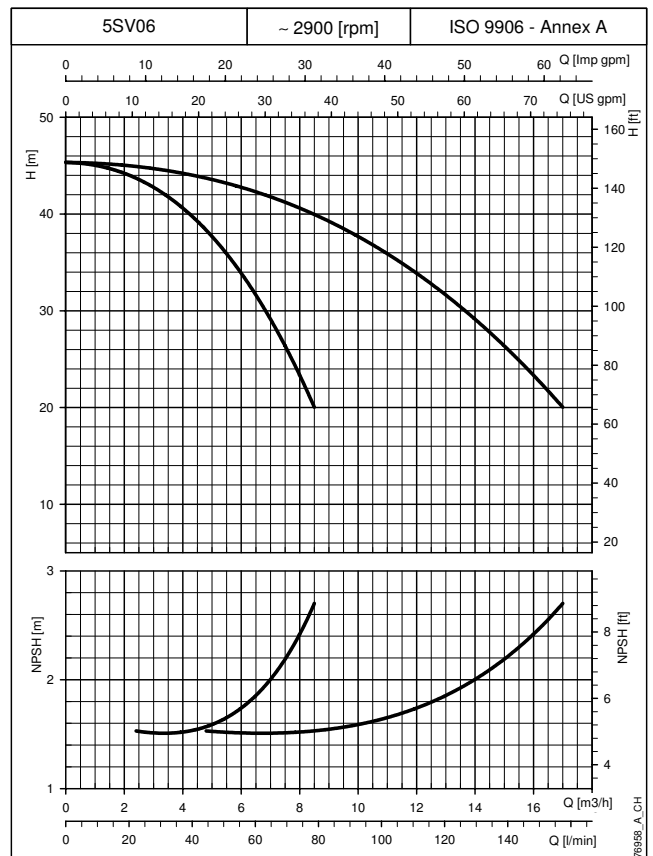
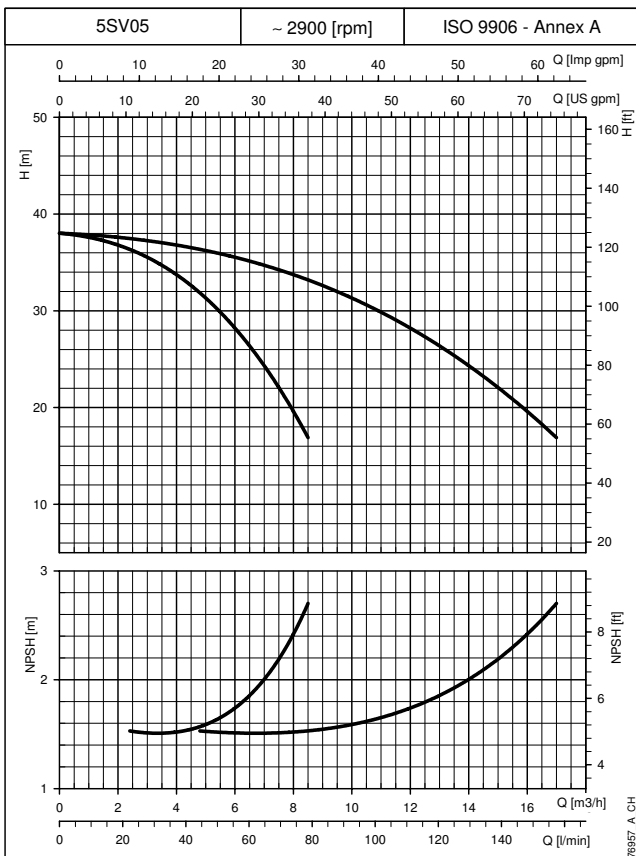
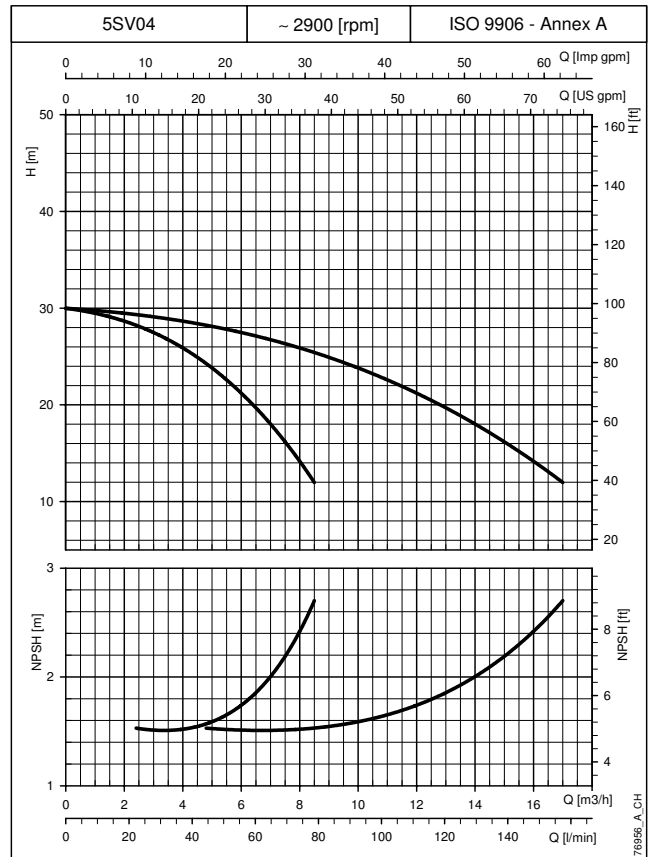
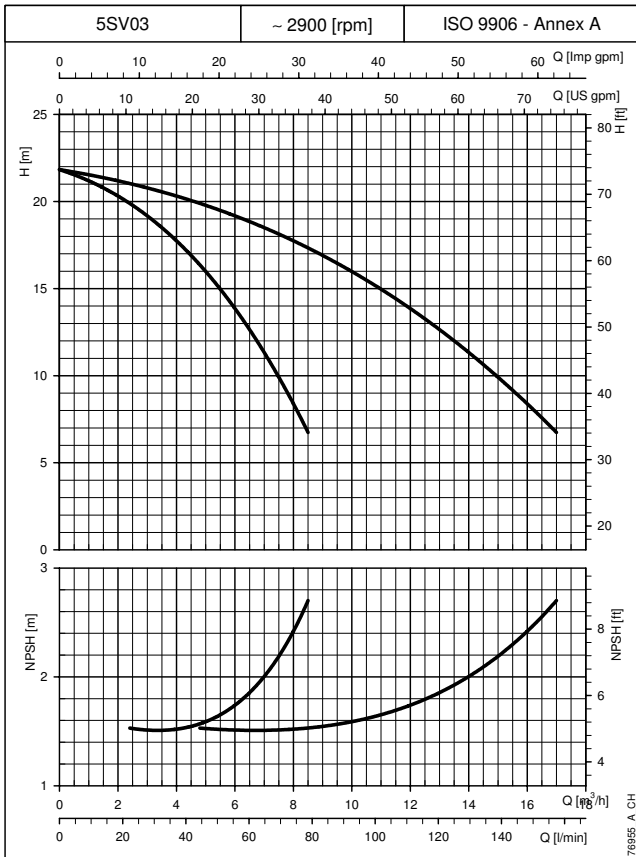

The performance curves do not take into account flow resistance in the valves and piping.
 The curves show the performance with one and two pumps running.
 These performances are valid for liquids with density $\rho = 1.0 \text{ Kg/dm}^3$ and kinematic viscosity $\nu = 1 \text{ mm}^2/\text{s}$.
 The declared NPSH values are laboratory values: for practical use we recommend increasing these values by 0,5 m.

CURVES

TWO-PUMP BOOSTER SETS OPERATING CHARACTERISTICS AT 50 Hz

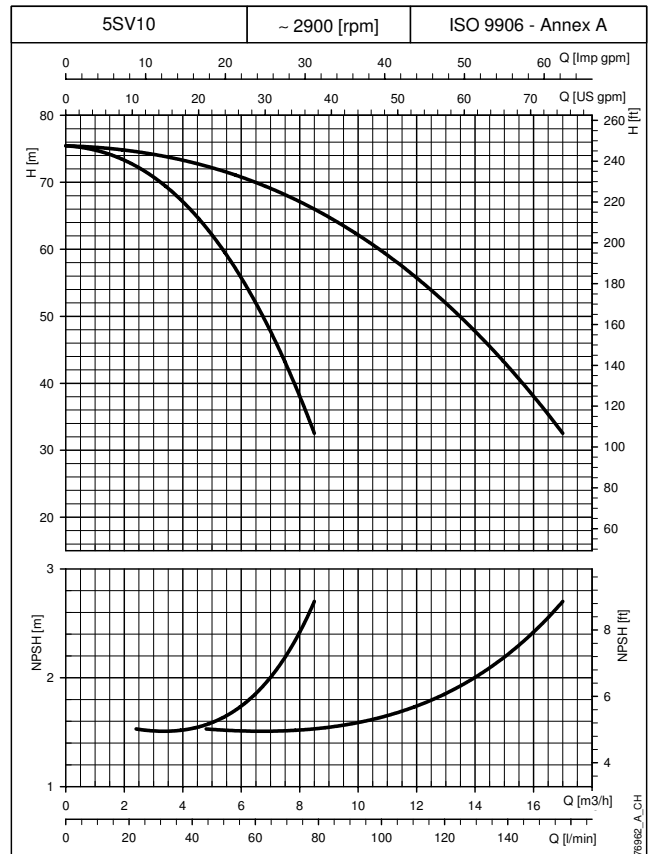
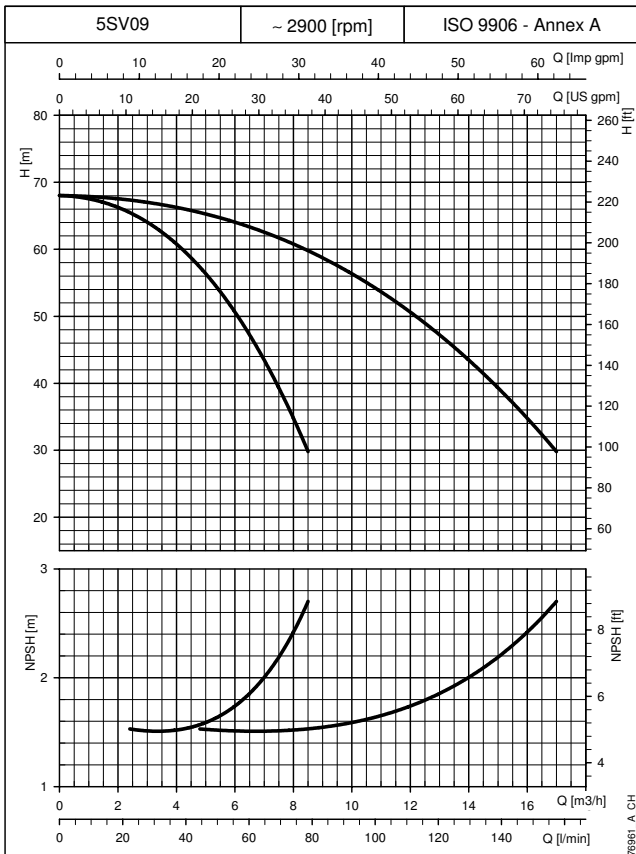
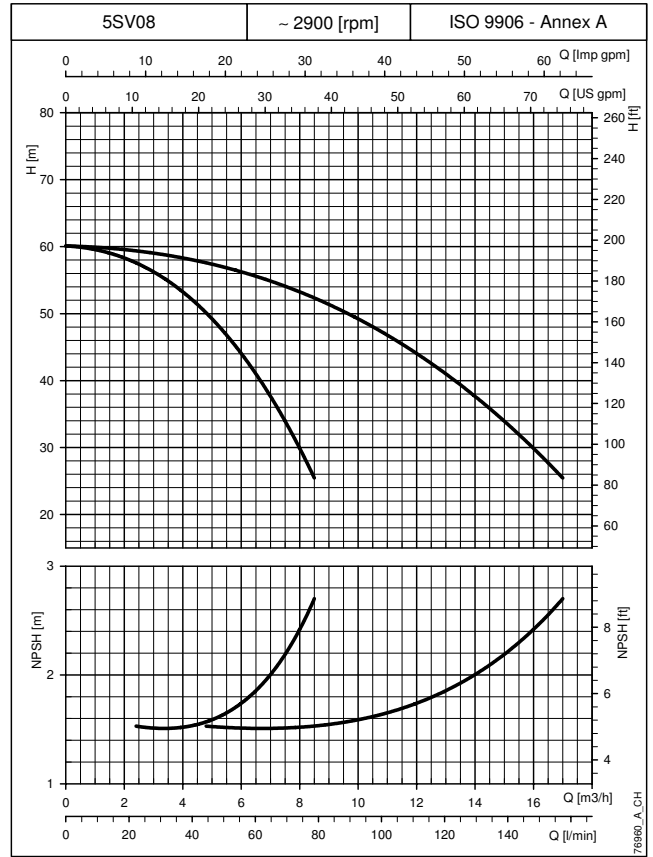
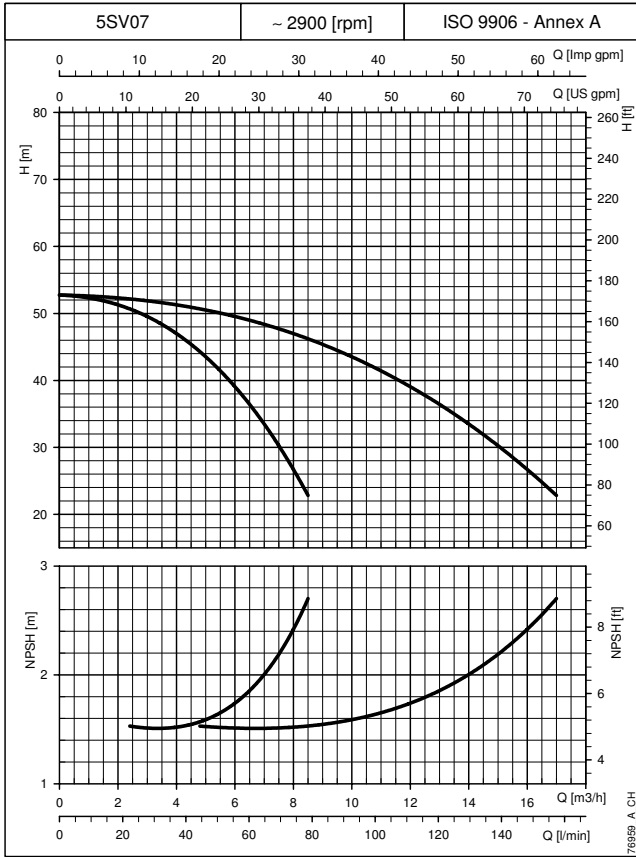

CURVES

The performance curves do not take into account flow resistance in the valves and piping.
The curves show the performance with one and two pumps running.
These performances are valid for liquids with density $\rho = 1.0 \text{ Kg/dm}^3$ and kinematic viscosity $\nu = 1 \text{ mm}^2/\text{s}$.
The declared NPSH values are laboratory values: for practical use we recommend increasing these values by 0,5 m.

**TWO-PUMP BOOSTER SETS
OPERATING CHARACTERISTICS AT 50 Hz**

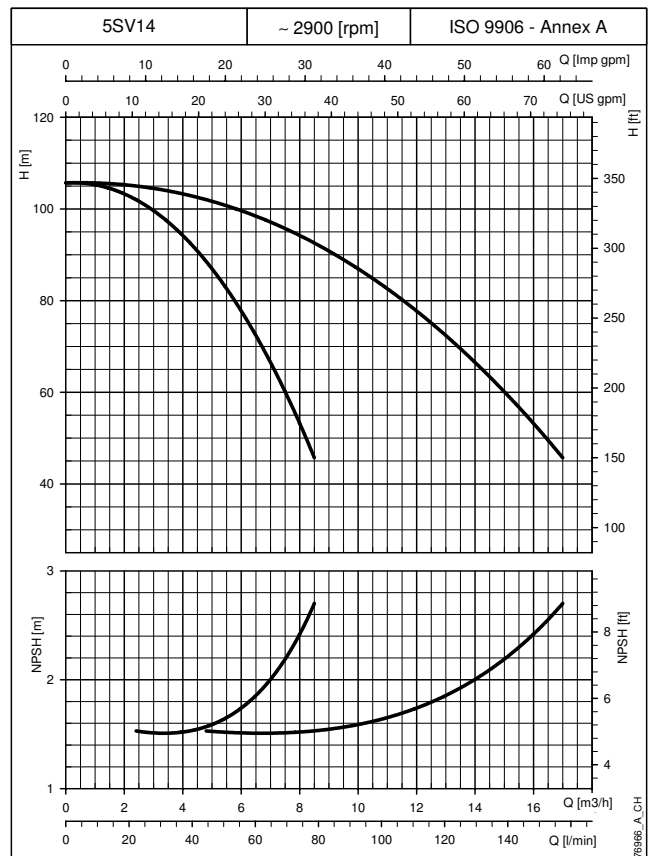
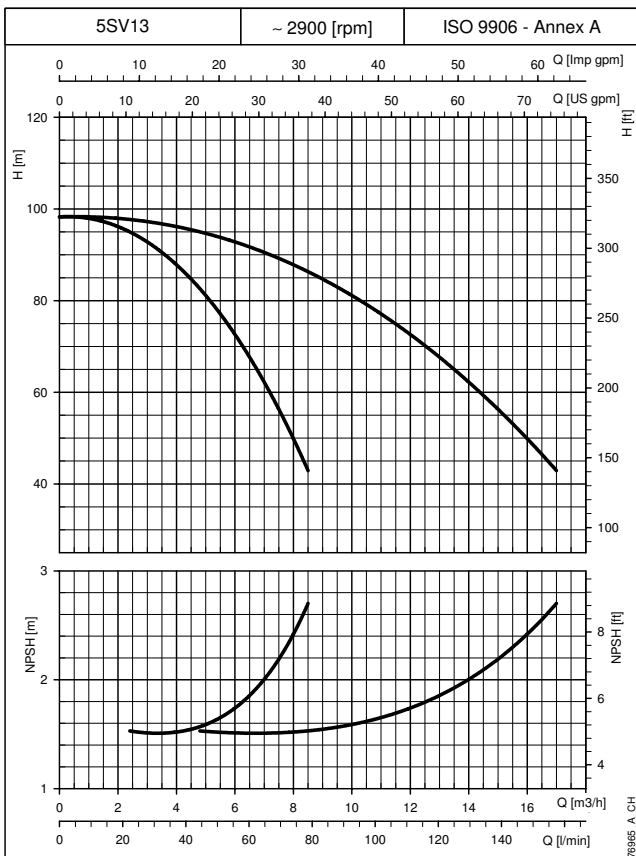
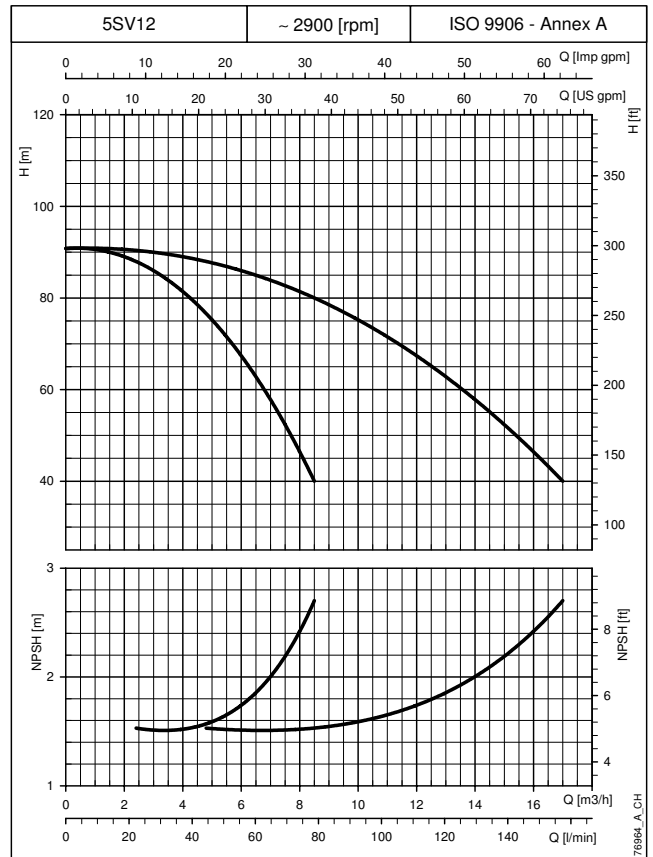
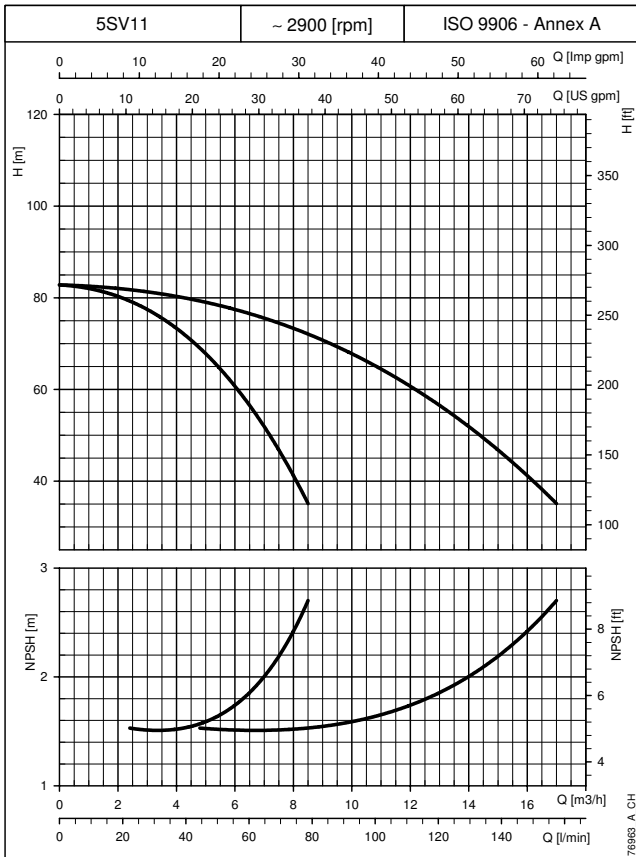

The performance curves do not take into account flow resistance in the valves and piping.
The curves show the performance with one and two pumps running.
These performances are valid for liquids with density $\rho = 1.0 \text{ Kg/dm}^3$ and kinematic viscosity $\nu = 1 \text{ mm}^2/\text{s}$.
The declared NPSH values are laboratory values: for practical use we recommend increasing these values by 0,5 m.

CURVES

TWO-PUMP BOOSTER SETS OPERATING CHARACTERISTICS AT 50 Hz

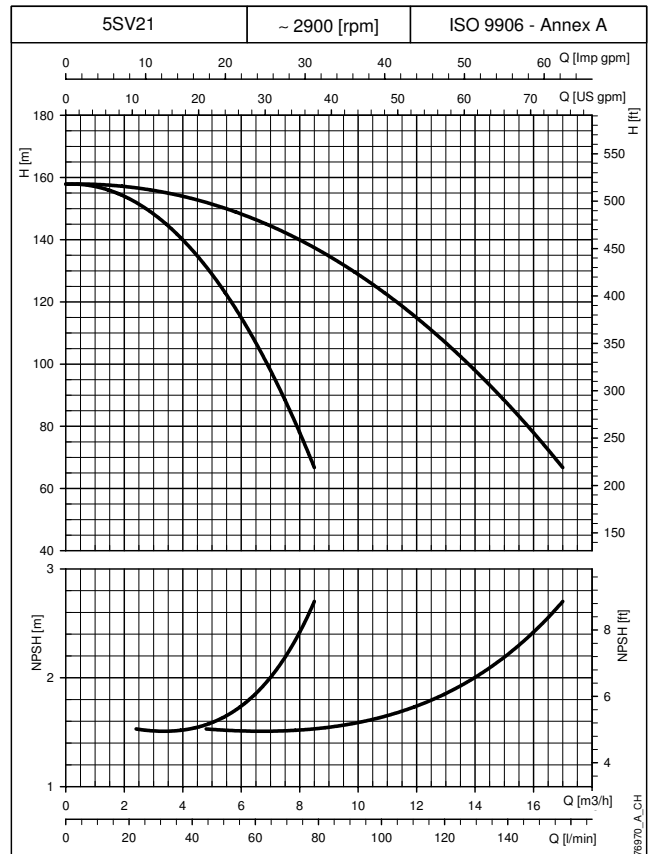
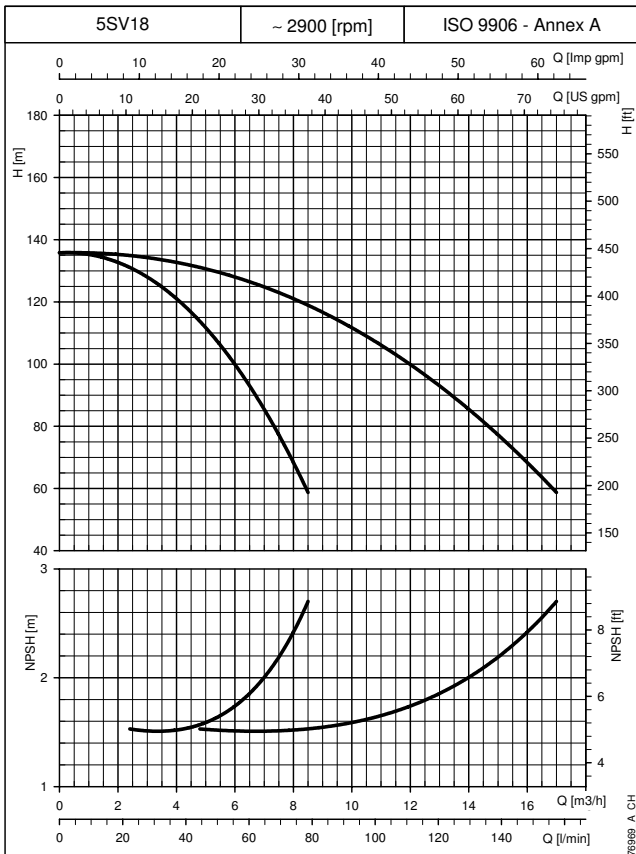
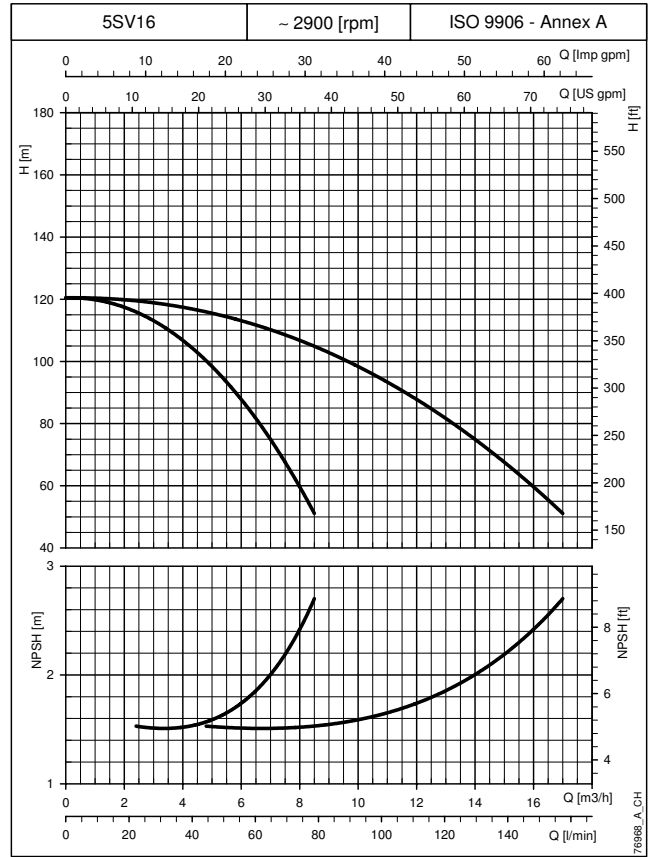
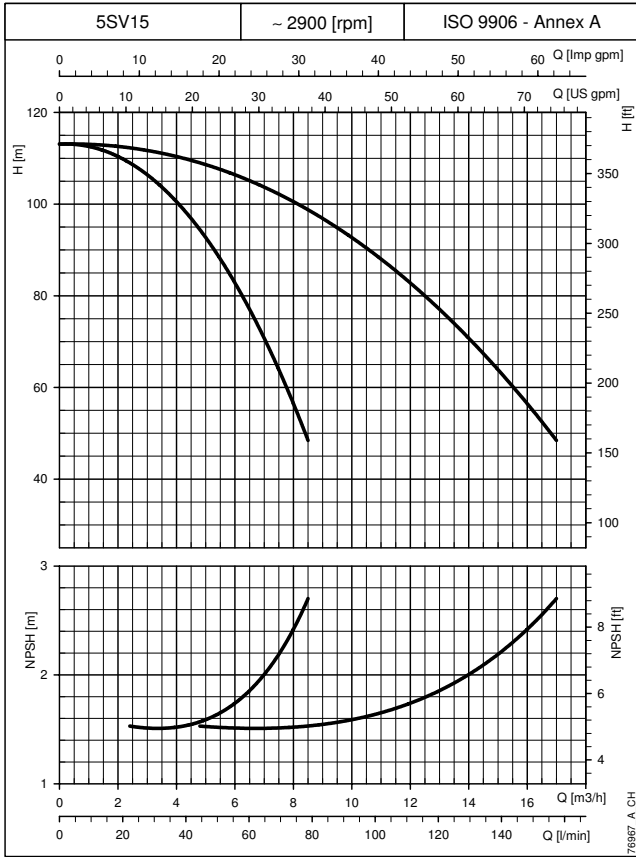

CURVES

The performance curves do not take into account flow resistance in the valves and piping.
 The curves show the performance with one and two pumps running.
 These performances are valid for liquids with density $\rho = 1.0 \text{ Kg/dm}^3$ and kinematic viscosity $\nu = 1 \text{ mm}^2/\text{s}$.
 The declared NPSH values are laboratory values: for practical use we recommend increasing these values by 0,5 m.

TWO-PUMP BOOSTER SETS OPERATING CHARACTERISTICS AT 50 Hz

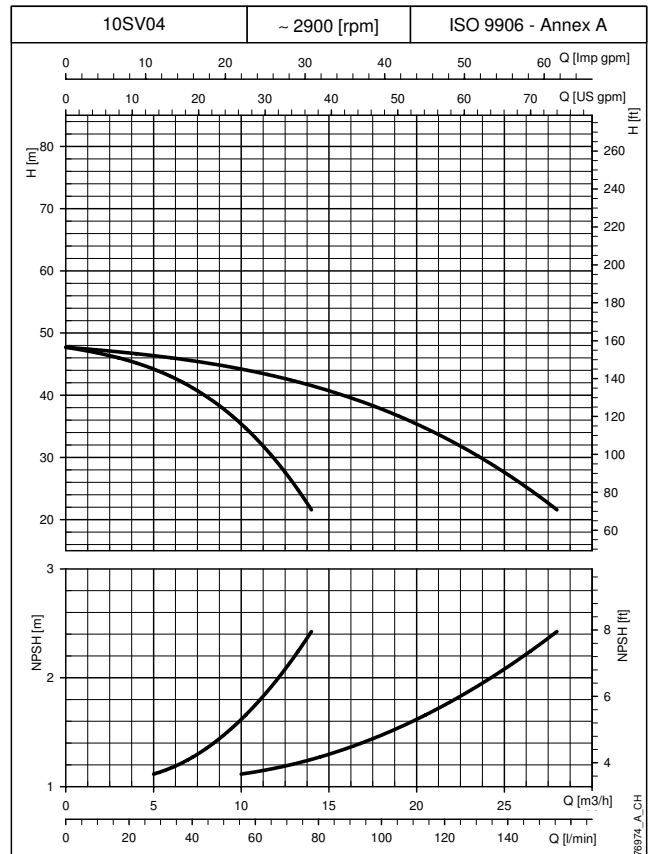
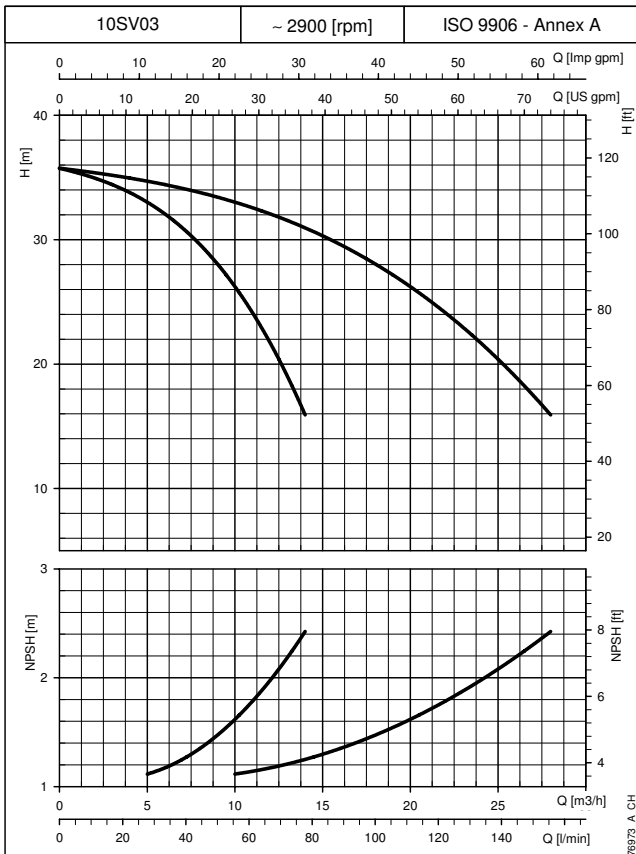
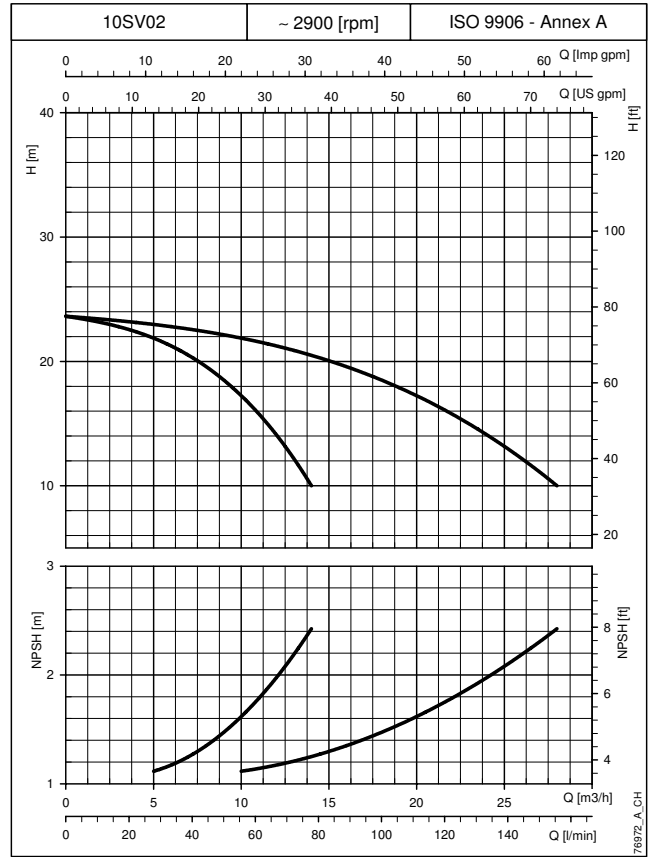
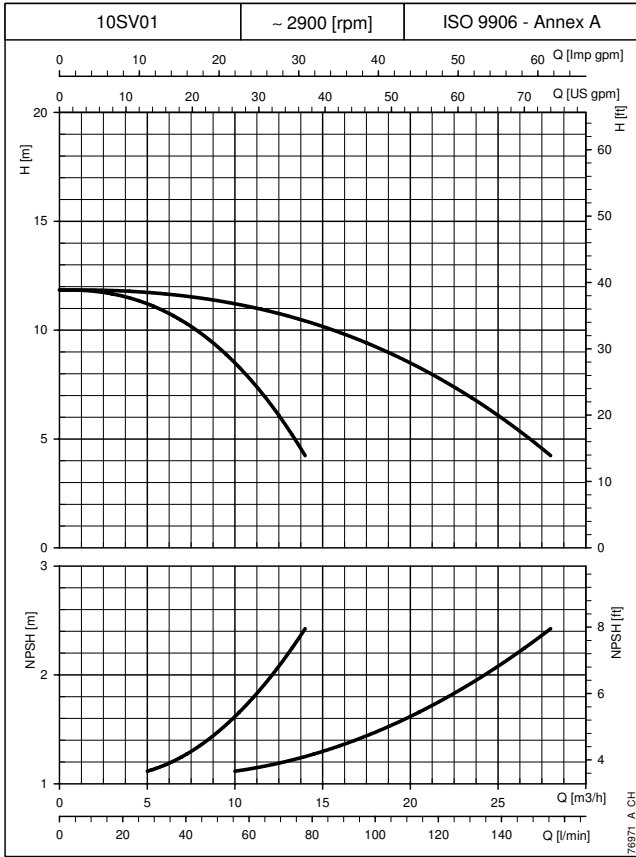

The performance curves do not take into account flow resistance in the valves and piping.
 The curves show the performance with one and two pumps running.
 These performances are valid for liquids with density $\rho = 1.0 \text{ Kg/dm}^3$ and kinematic viscosity $\nu = 1 \text{ mm}^2/\text{s}$.
 The declared NPSH values are laboratory values: for practical use we recommend increasing these values by 0,5 m.

CURVES

TWO-PUMP BOOSTER SETS OPERATING CHARACTERISTICS AT 50 Hz

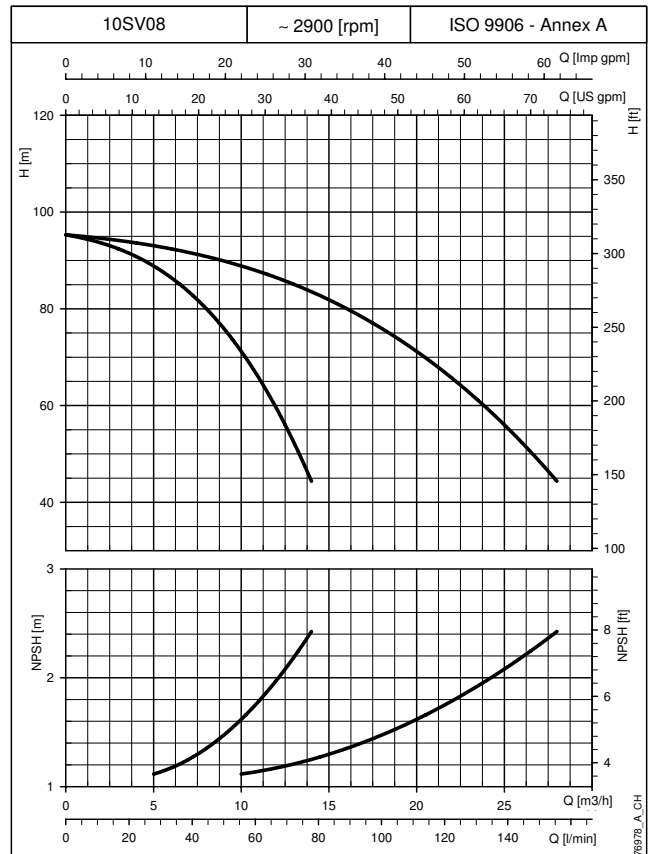
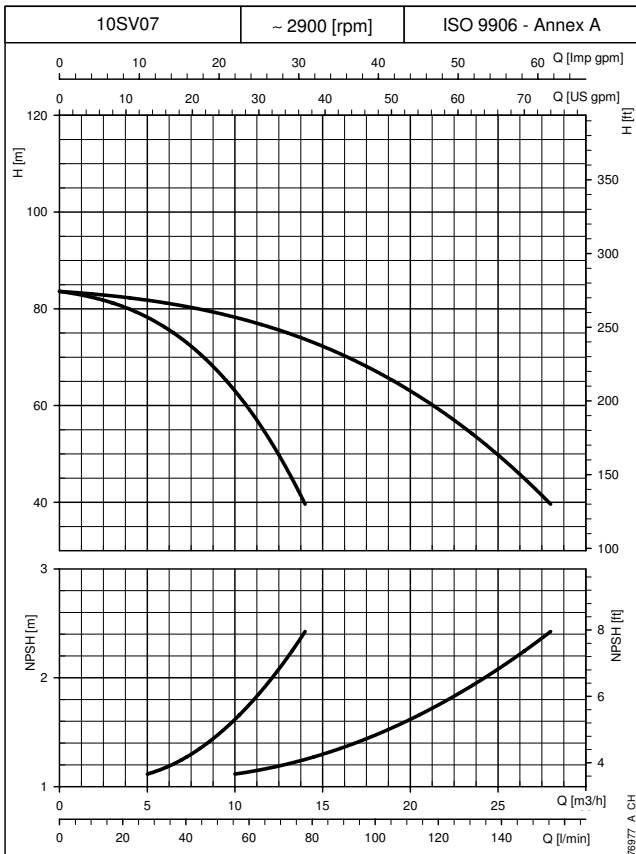
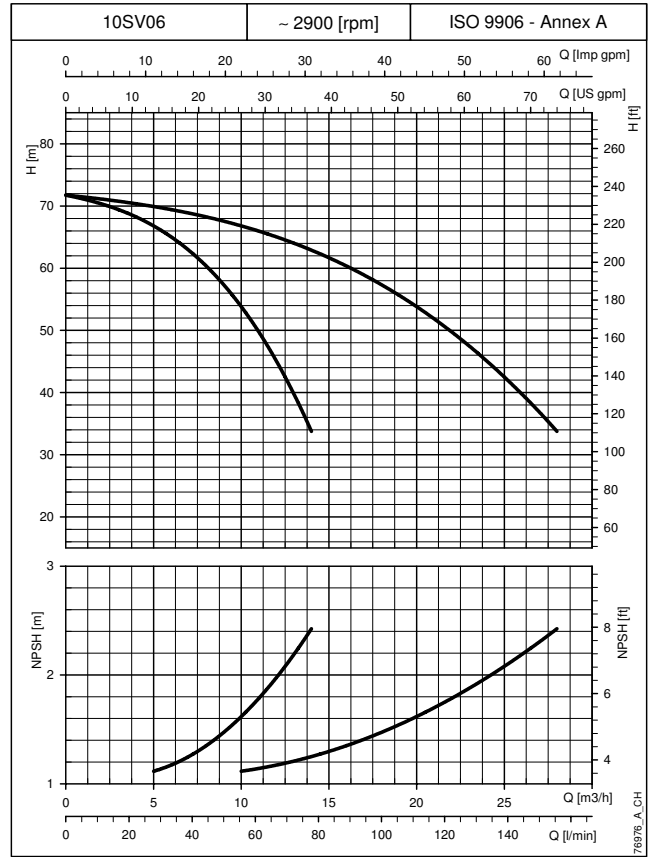
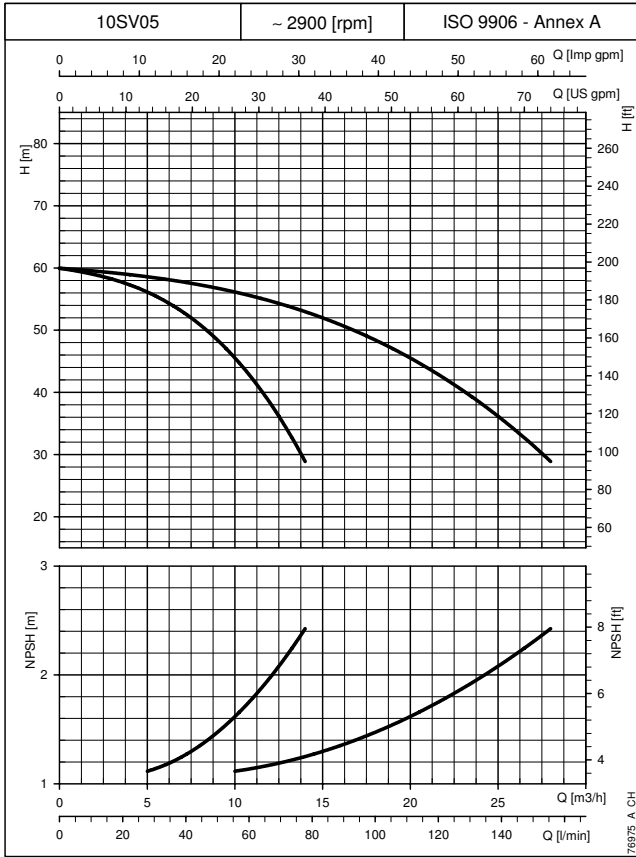

CURVES

The performance curves do not take into account flow resistance in the valves and piping.
 The curves show the performance with one and two pumps running.
 These performances are valid for liquids with density $\rho = 1.0 \text{ Kg/dm}^3$ and kinematic viscosity $\nu = 1 \text{ mm}^2/\text{s}$.
 The declared NPSH values are laboratory values: for practical use we recommend increasing these values by 0,5 m.

**TWO-PUMP BOOSTER SETS
OPERATING CHARACTERISTICS AT 50 Hz**

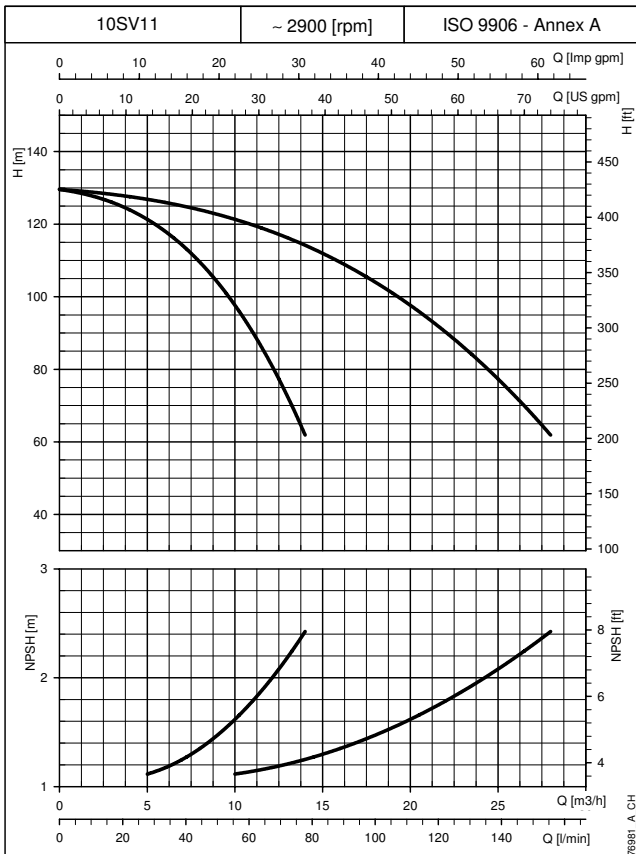
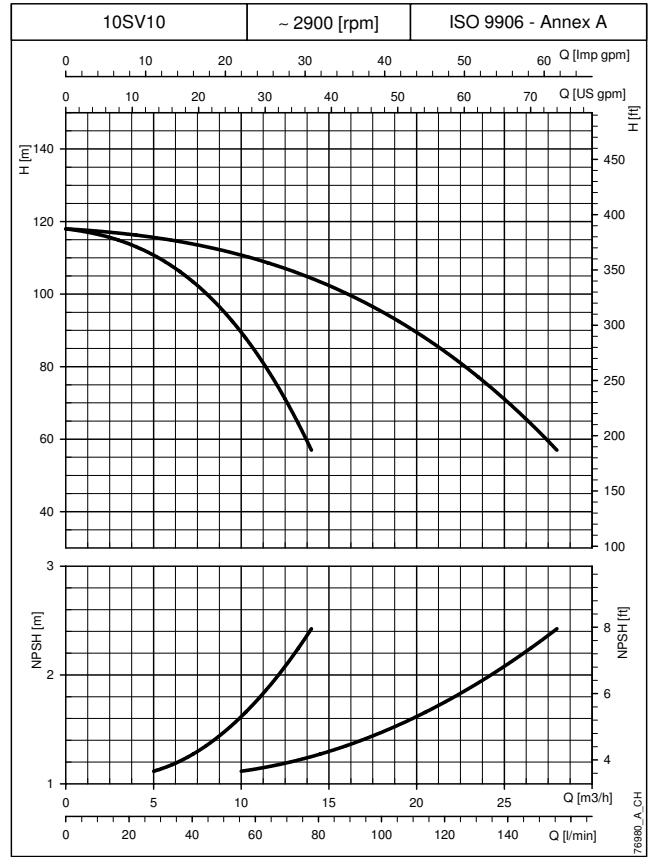
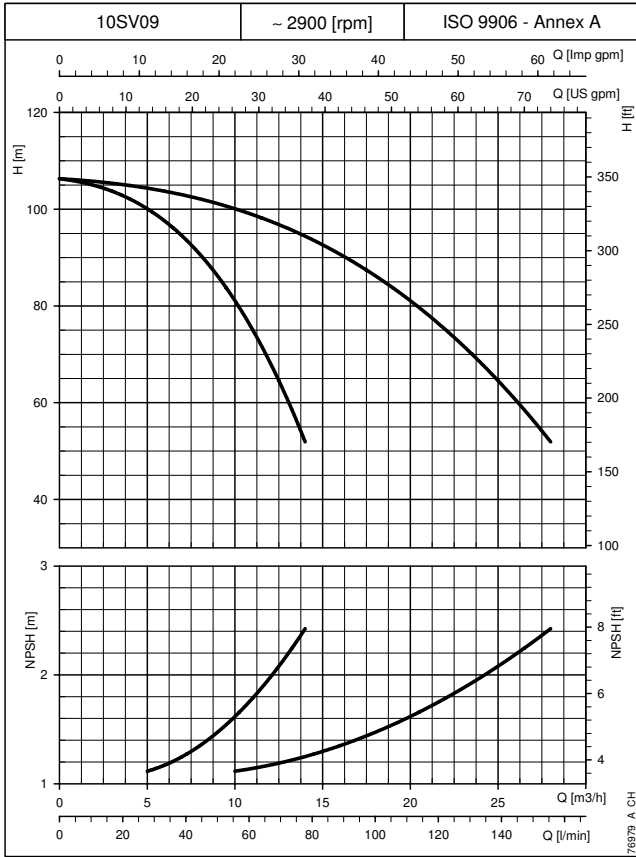

The performance curves do not take into account flow resistance in the valves and piping.
 The curves show the performance with one and two pumps running.
 These performances are valid for liquids with density $\rho = 1.0 \text{ Kg/dm}^3$ and kinematic viscosity $\nu = 1 \text{ mm}^2/\text{s}$.
 The declared NPSH values are laboratory values: for practical use we recommend increasing these values by 0,5 m.

**TWO-PUMP BOOSTER SETS
OPERATING CHARACTERISTICS AT 30..50 Hz**

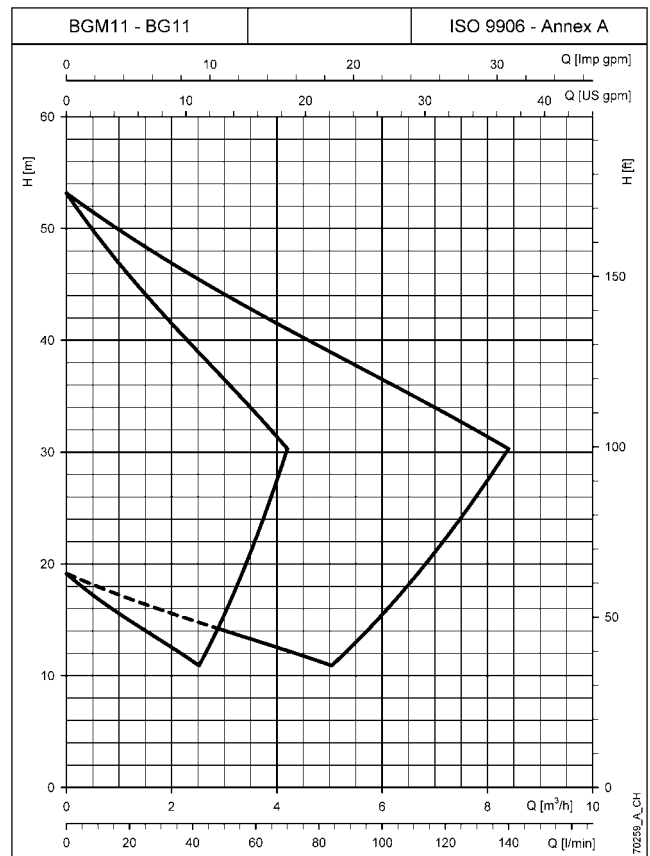
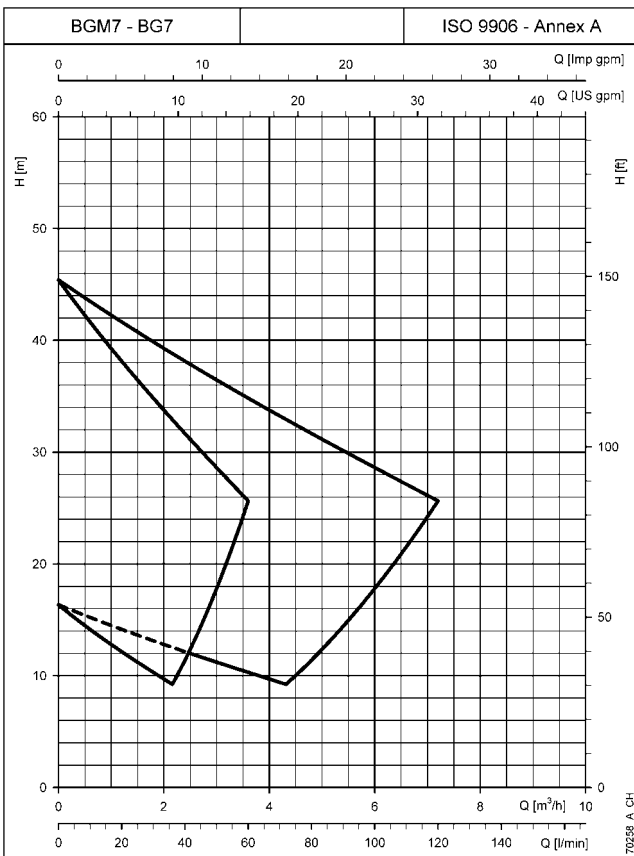
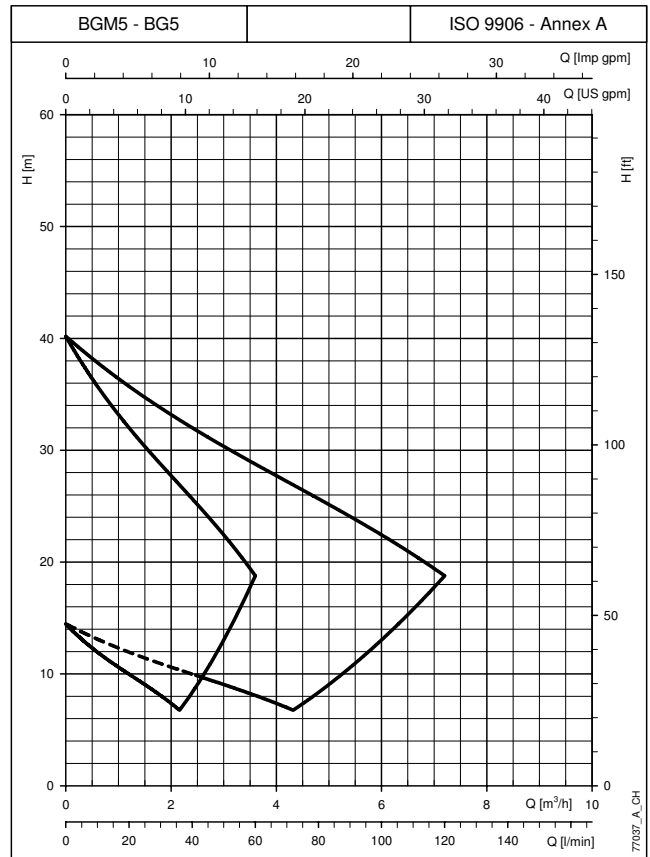
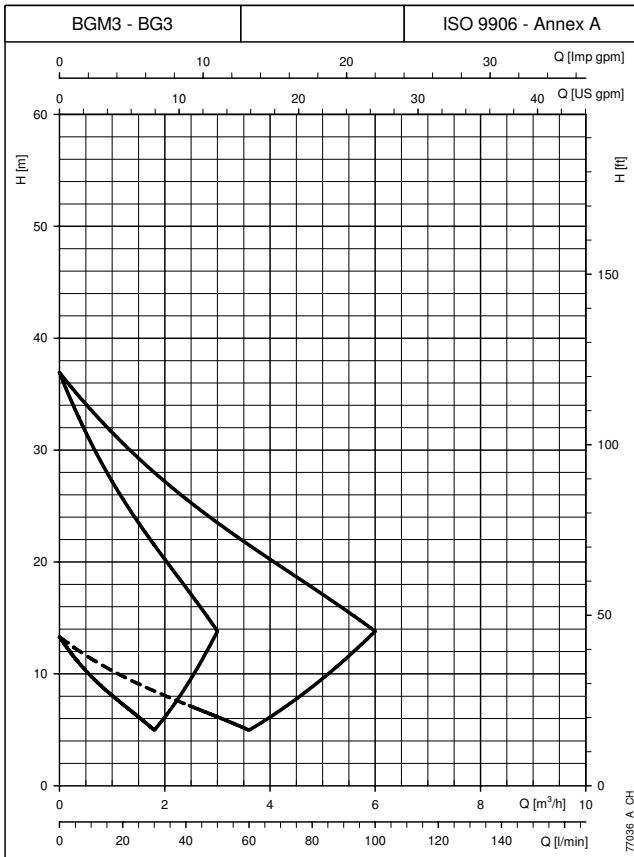

CURVES

The performance curves do not take into account flow resistance in the valves and piping.
The curves show the performance with one and two pumps running.
These performances are valid for liquids with density $\rho = 1.0 \text{ Kg/dm}^3$ and kinematic viscosity $\nu = 1 \text{ mm}^2/\text{s}$.
The declared NPSH values are laboratory values: for practical use we recommend increasing these values by 0,5 m.

**TWO-PUMP BOOSTER SETS
OPERATING CHARACTERISTICS AT 30..50 Hz**

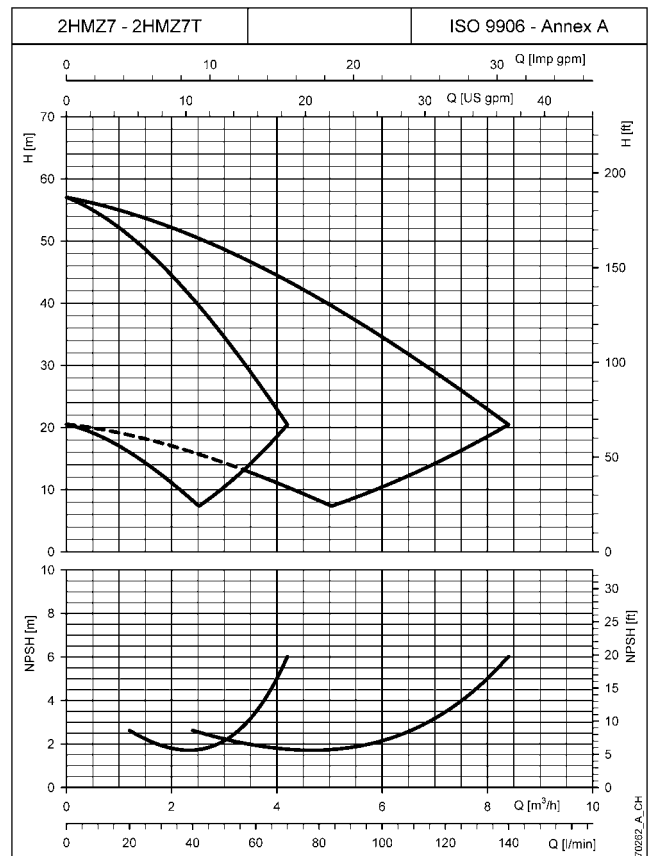
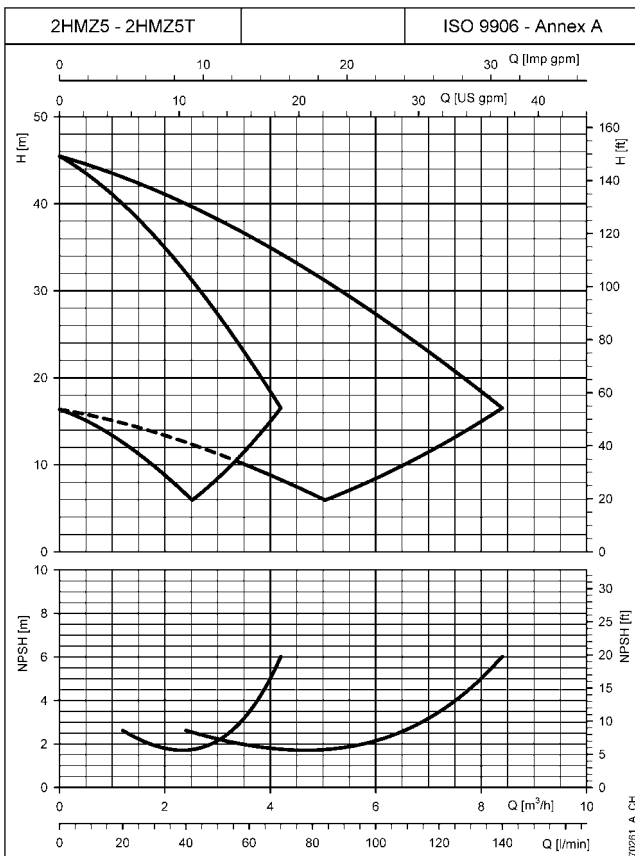
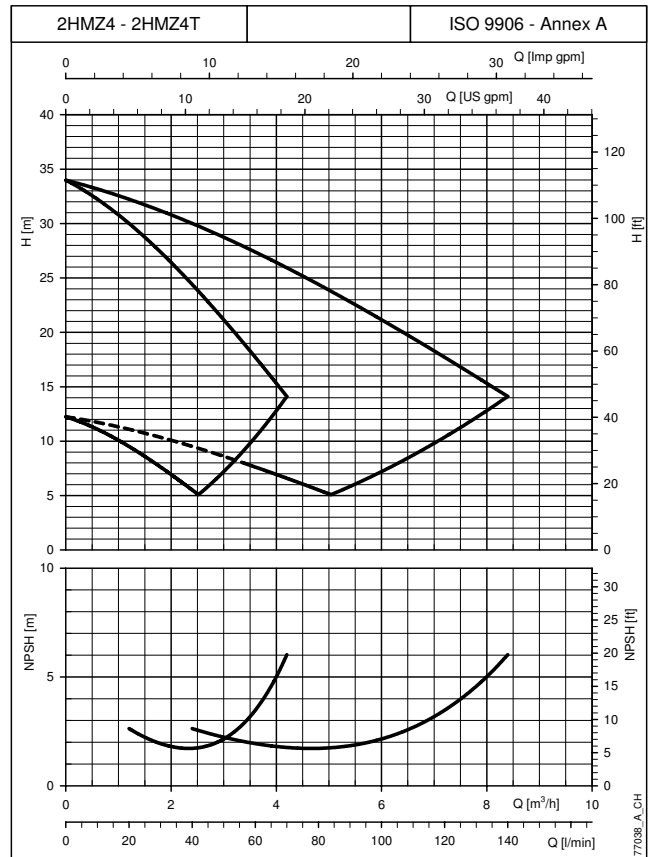
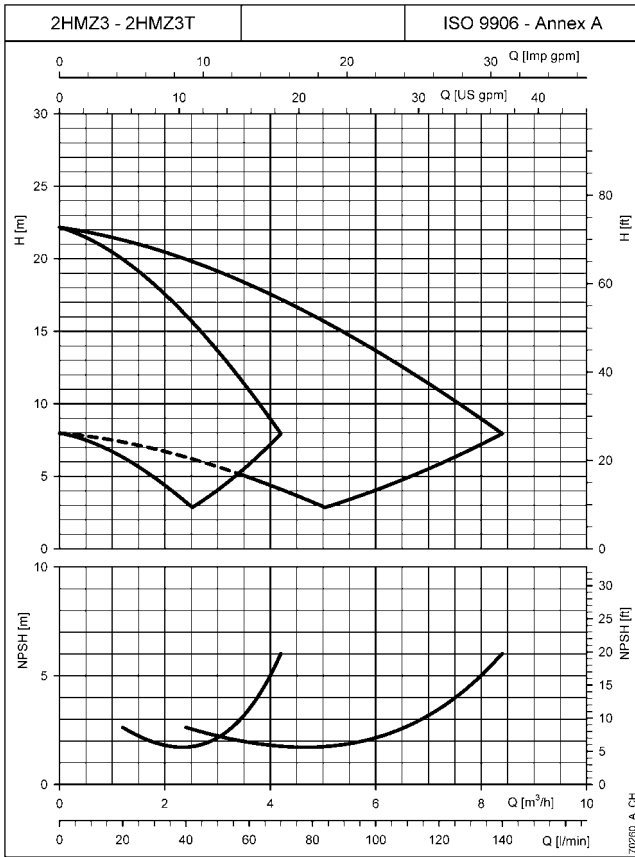

The performance curves do not take into account flow resistance in the valves and piping.
The curves show the performance with one and two pumps running.
These performances are valid for liquids with density $\rho = 1.0 \text{ Kg/dm}^3$ and kinematic viscosity $\nu = 1 \text{ mm}^2/\text{s}$.
The declared NPSH values are laboratory values: for practical use we recommend increasing these values by 0,5 m.

CURVES

**TWO-PUMP BOOSTER SETS
OPERATING CHARACTERISTICS AT 30..50 Hz**

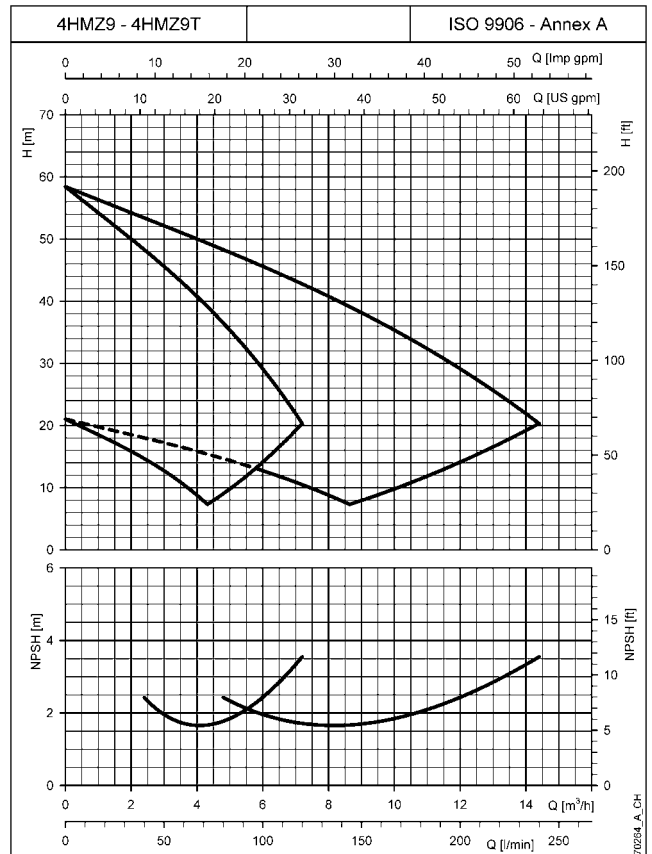
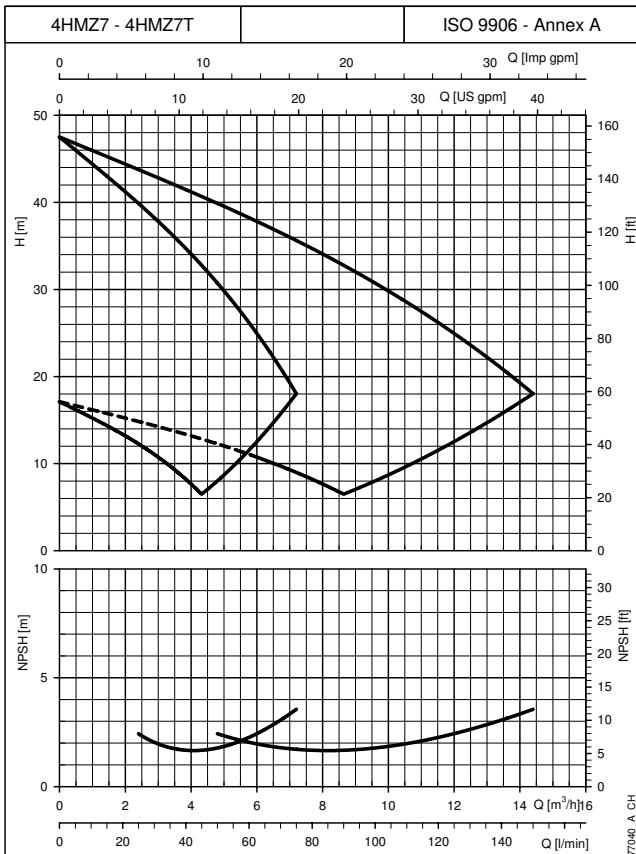
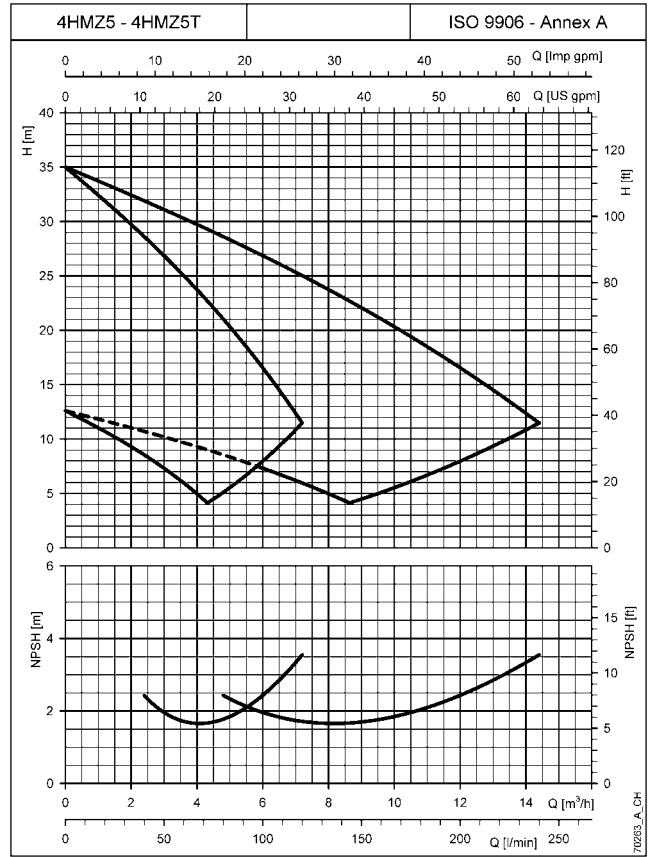
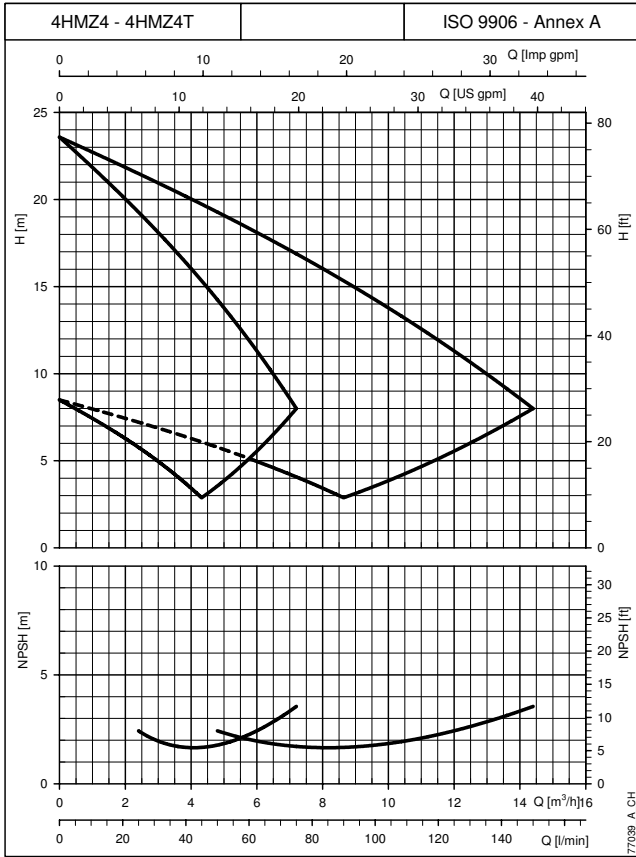

CURVES

The performance curves do not take into account flow resistance in the valves and piping.
The curves show the performance with one and two pumps running.
These performances are valid for liquids with density $\rho = 1.0 \text{ Kg/dm}^3$ and kinematic viscosity $\nu = 1 \text{ mm}^2/\text{s}$.
The declared NPSH values are laboratory values: for practical use we recommend increasing these values by 0,5 m.

TWO-PUMP BOOSTER SETS OPERATING CHARACTERISTICS AT 30..50 Hz

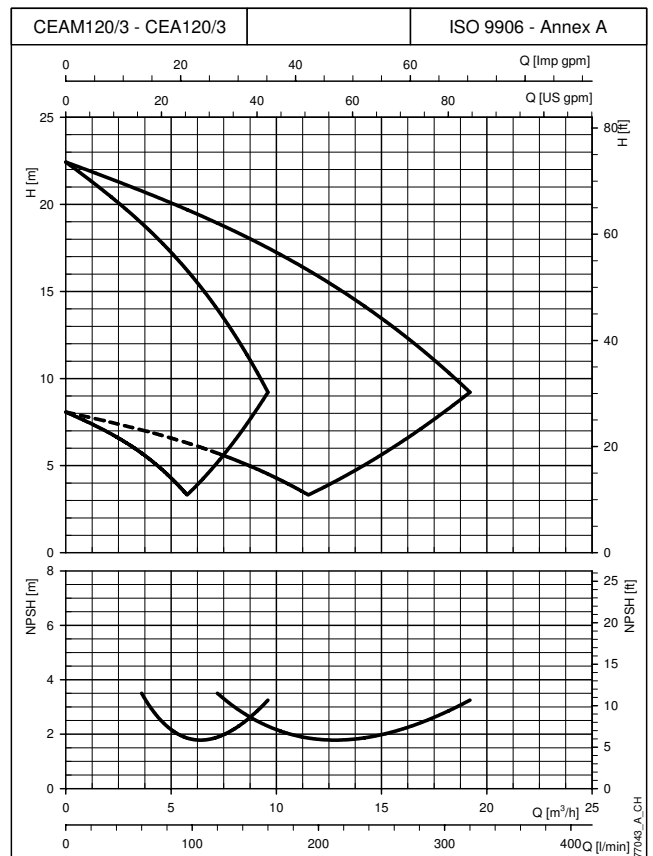
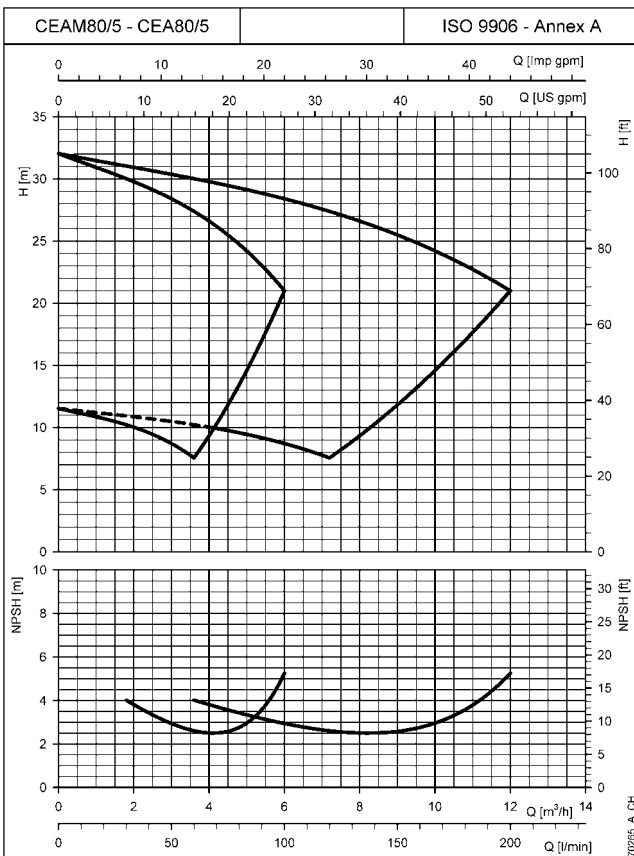
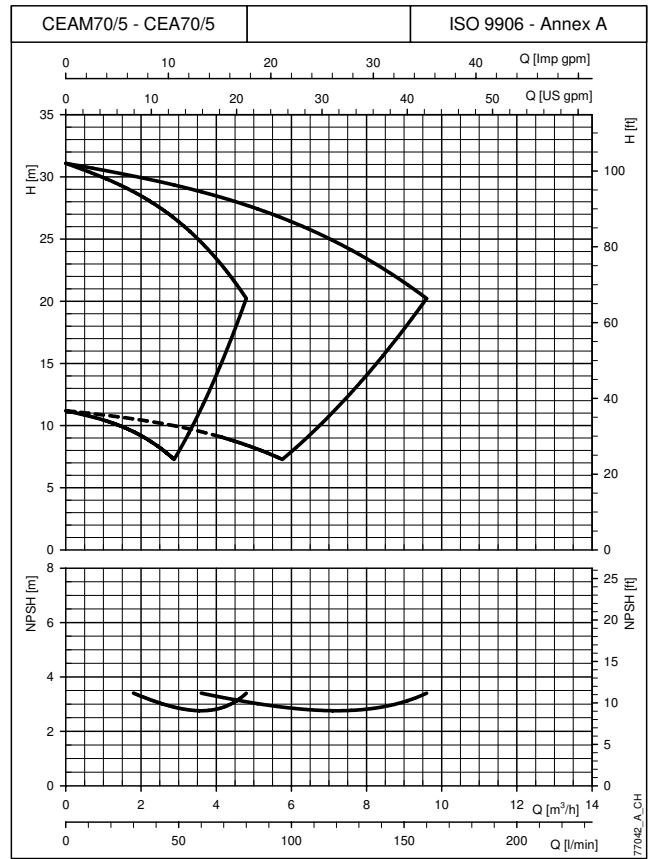
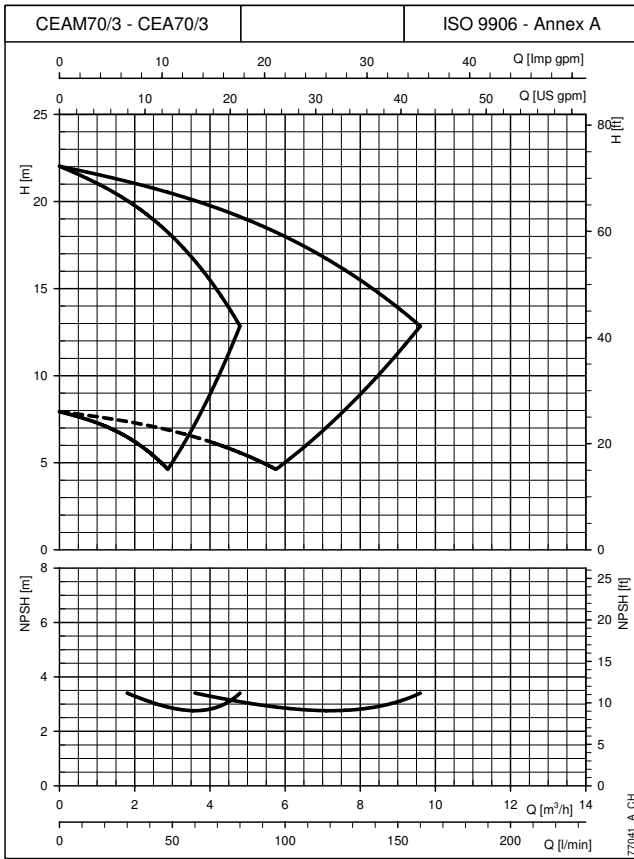

The performance curves do not take into account flow resistance in the valves and piping.
The curves show the performance with one and two pumps running.
These performances are valid for liquids with density $\rho = 1.0 \text{ Kg/dm}^3$ and kinematic viscosity $\nu = 1 \text{ mm}^2/\text{s}$.
The declared NPSH values are laboratory values: for practical use we recommend increasing these values by 0,5 m.

CURVES

**TWO-PUMP BOOSTER SETS
OPERATING CHARACTERISTICS AT 30..50 Hz**

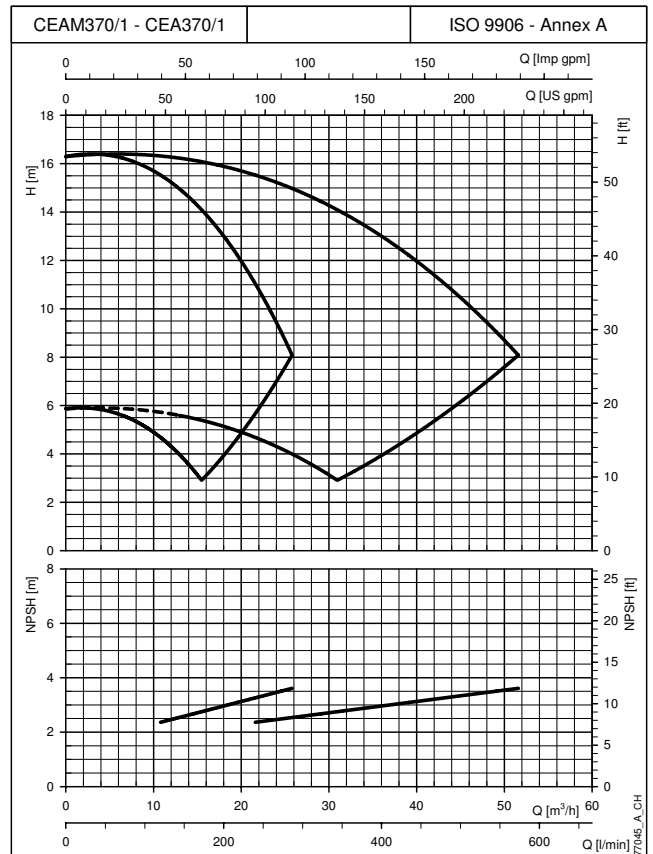
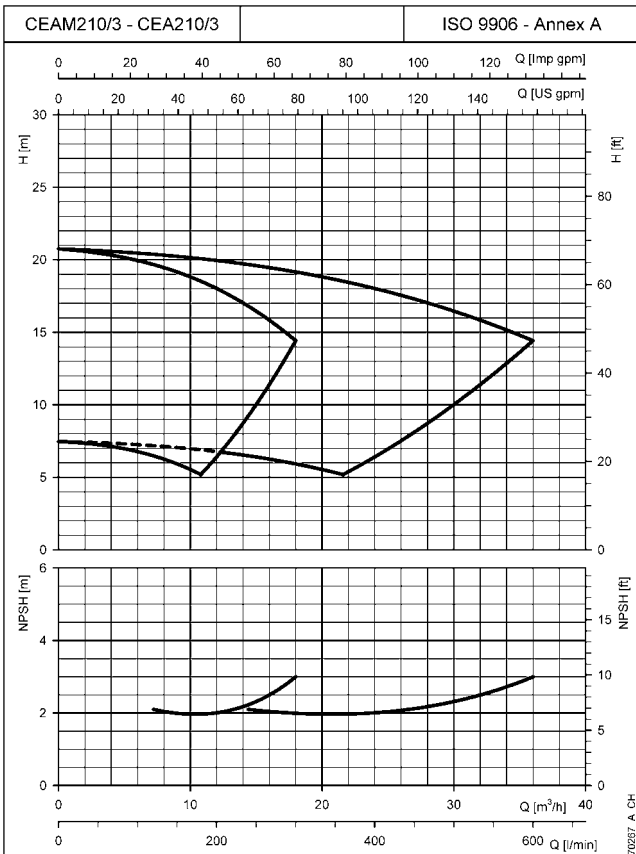
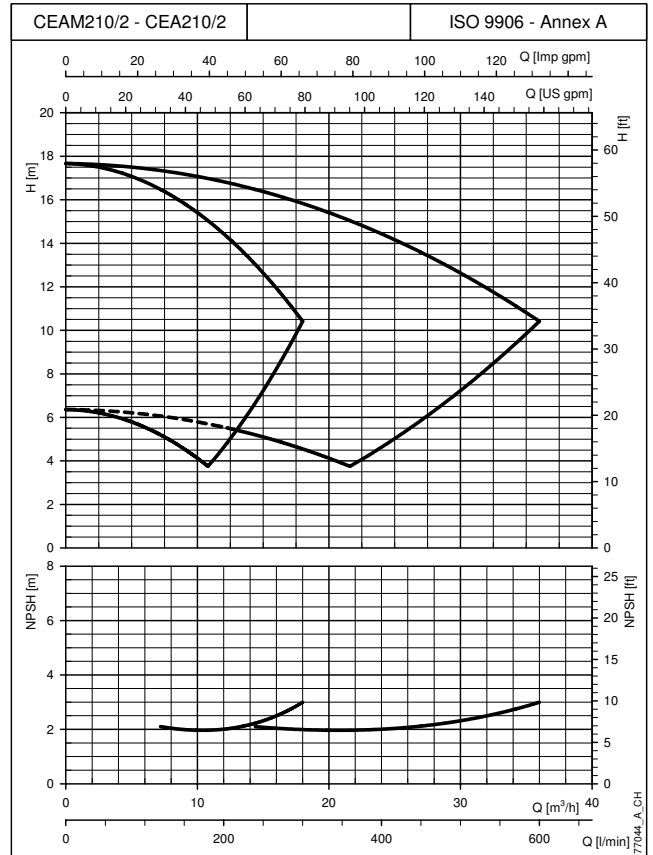
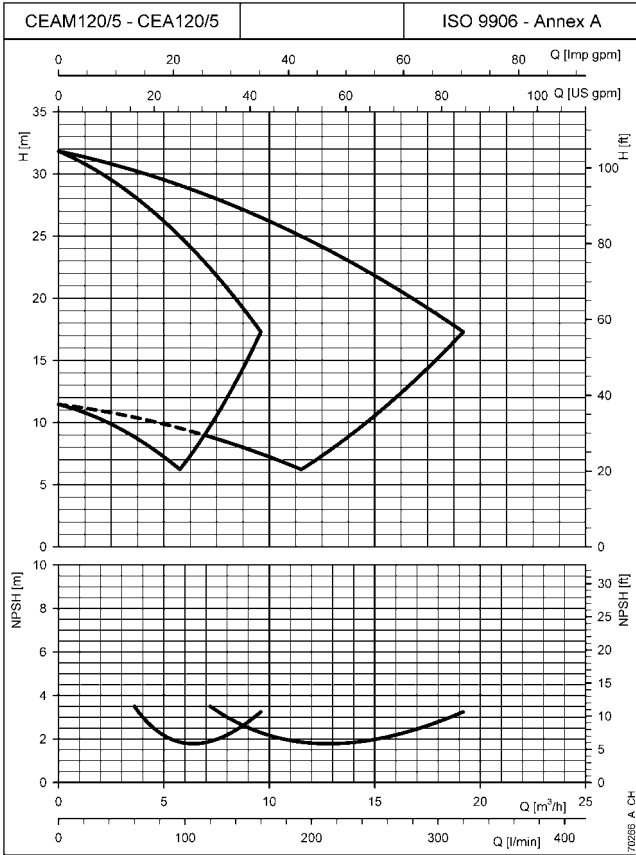

CURVES

The performance curves do not take into account flow resistance in the valves and piping.
The curves show the performance with one and two pumps running.
These performances are valid for liquids with density $\rho = 1.0 \text{ Kg/dm}^3$ and kinematic viscosity $\nu = 1 \text{ mm}^2/\text{s}$.
The declared NPSH values are laboratory values: for practical use we recommend increasing these values by 0,5 m.

TWO-PUMP BOOSTER SETS OPERATING CHARACTERISTICS AT 30..50 Hz

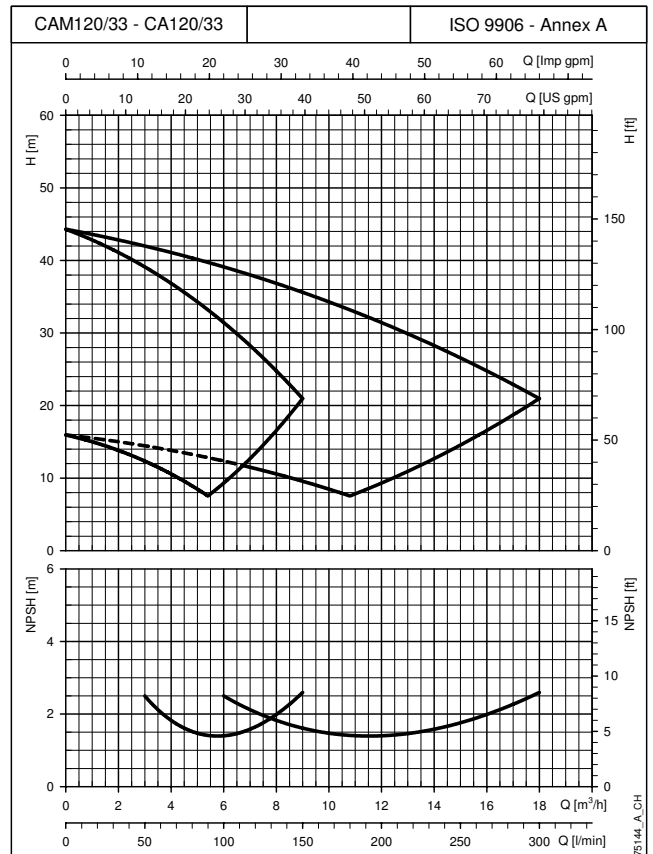
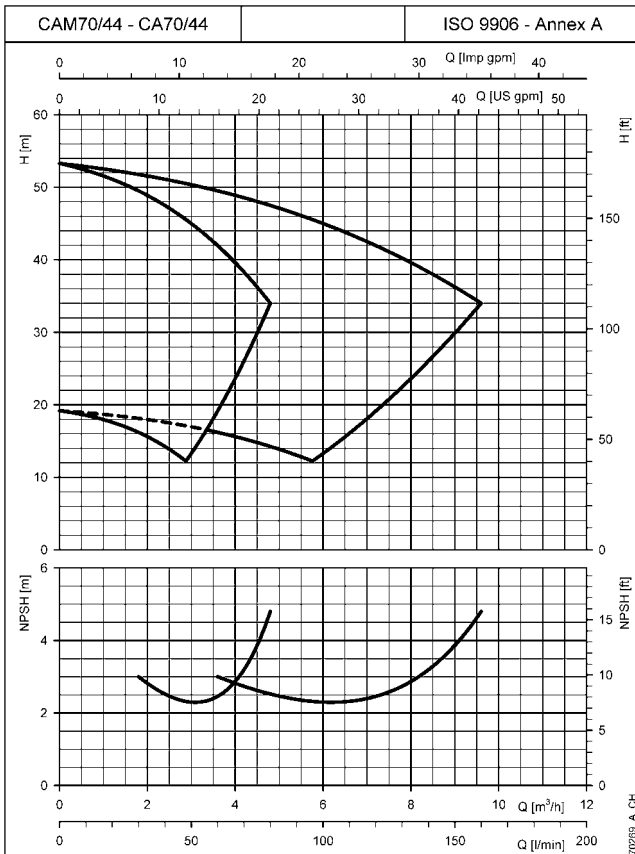
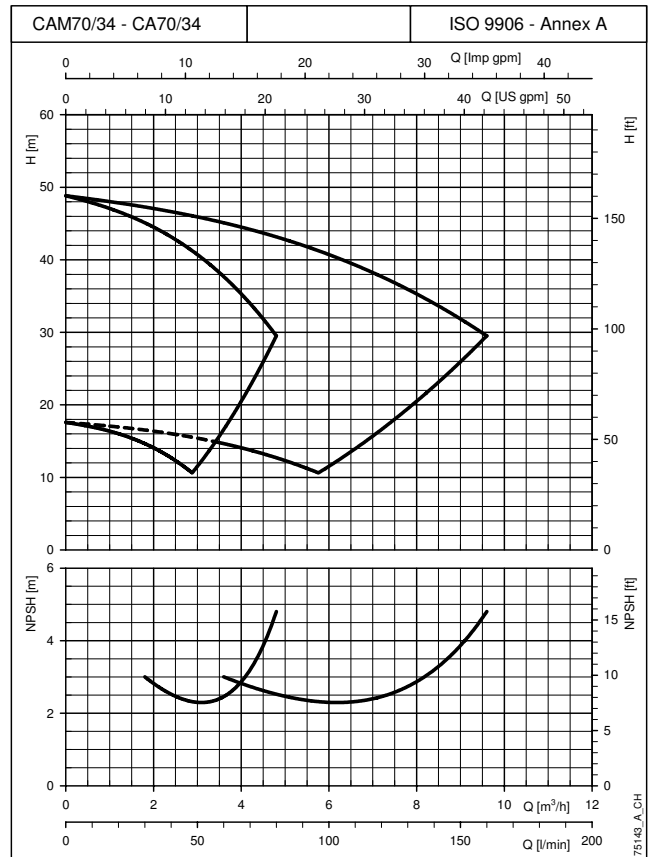
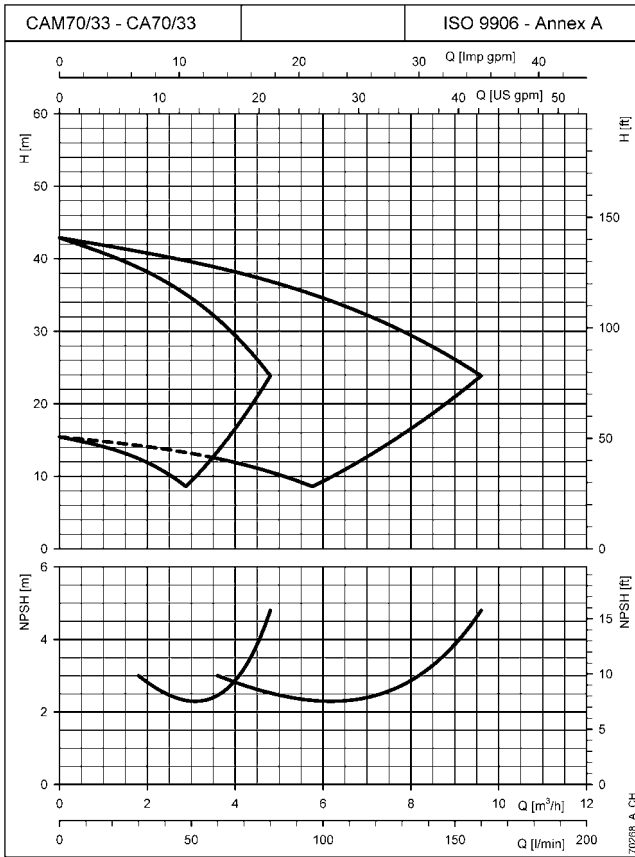

The performance curves do not take into account flow resistance in the valves and piping.
 The curves show the performance with one and two pumps running.
 These performances are valid for liquids with density $\rho = 1.0 \text{ Kg/dm}^3$ and kinematic viscosity $\nu = 1 \text{ mm}^2/\text{s}$.
 The declared NPSH values are laboratory values: for practical use we recommend increasing these values by 0,5 m.

CURVES

TWO-PUMP BOOSTER SETS OPERATING CHARACTERISTICS AT 30..50 Hz

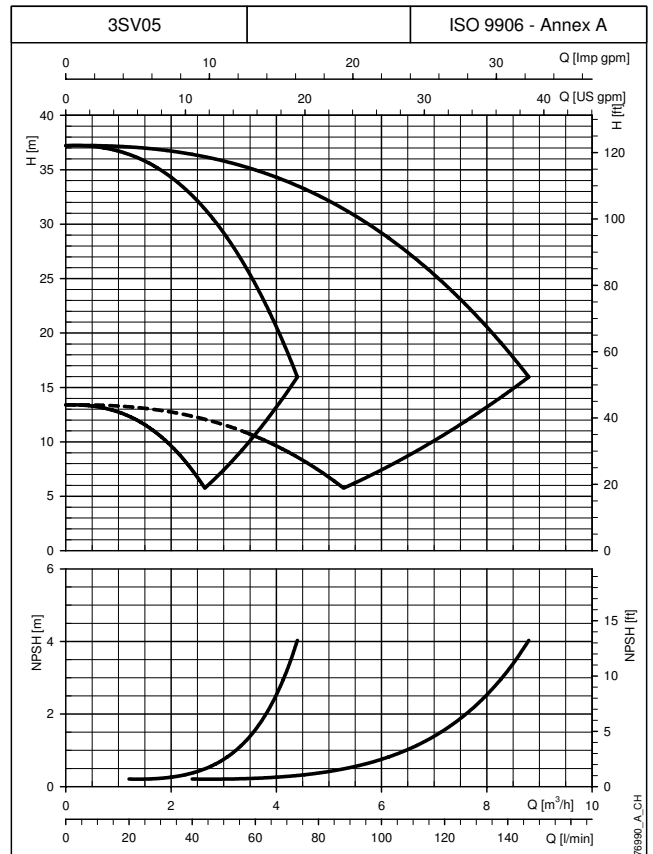
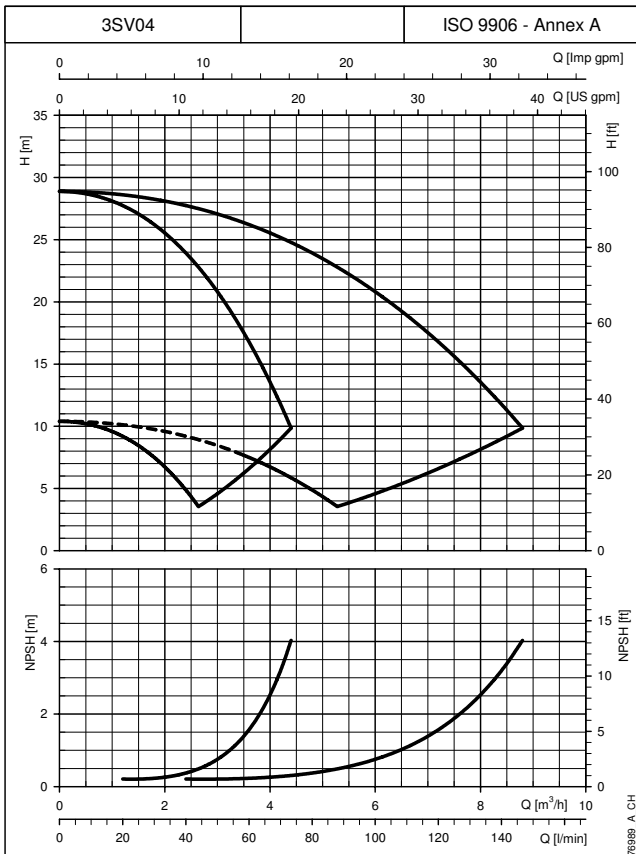
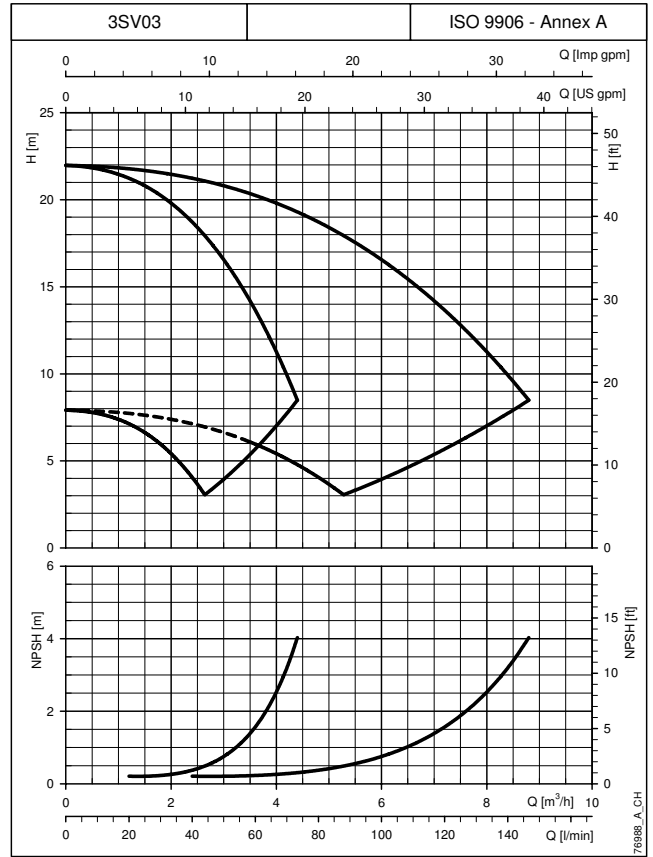
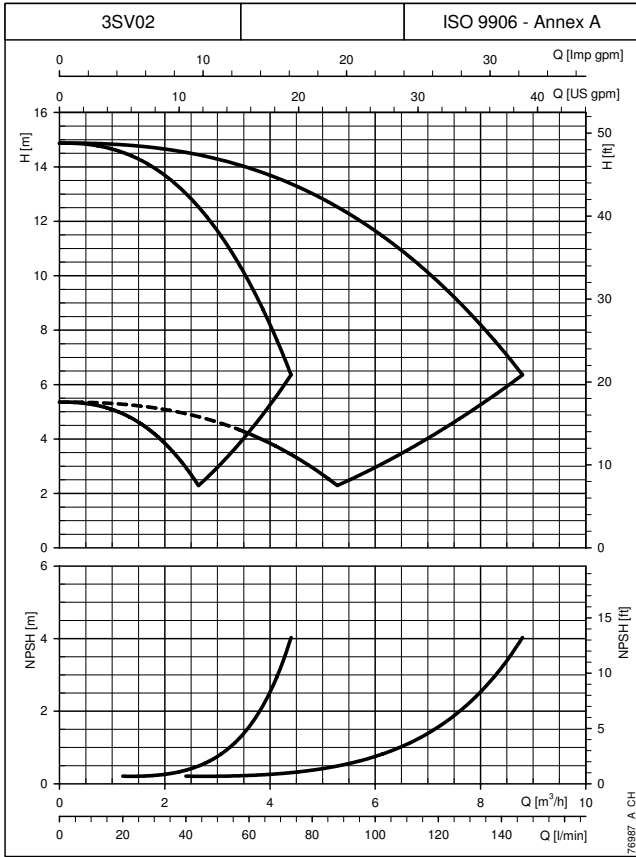

CURVES

The performance curves do not take into account flow resistance in the valves and piping.
 The curves show the performance with one and two pumps running.
 These performances are valid for liquids with density $\rho = 1.0 \text{ Kg/dm}^3$ and kinematic viscosity $\nu = 1 \text{ mm}^2/\text{s}$.
 The declared NPSH values are laboratory values: for practical use we recommend increasing these values by 0,5 m.

**TWO-PUMP BOOSTER SETS
OPERATING CHARACTERISTICS AT 30..50 Hz**

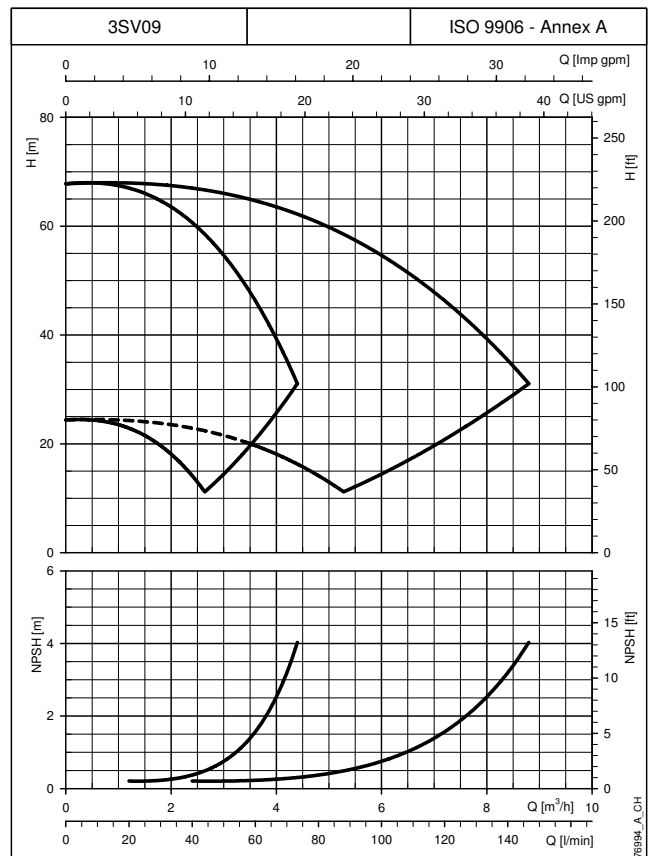
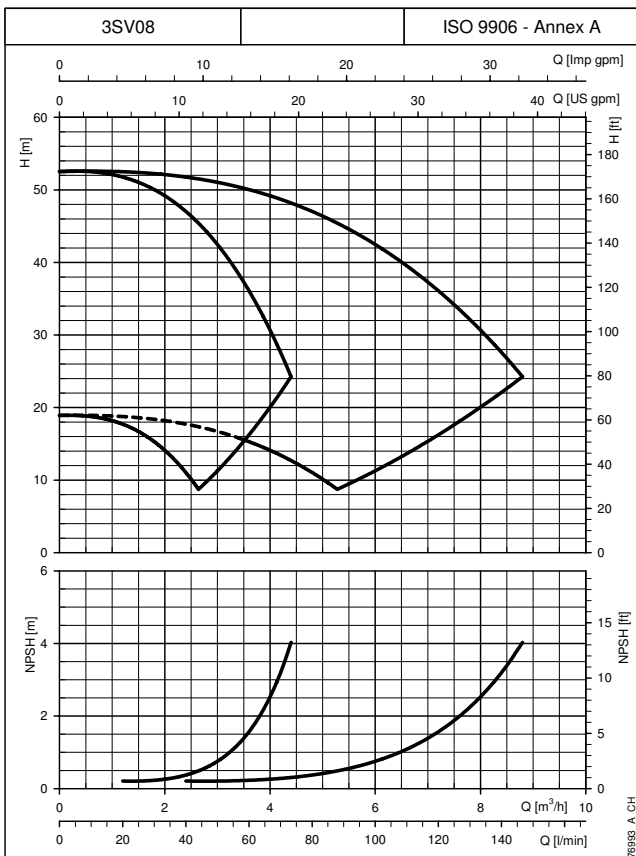
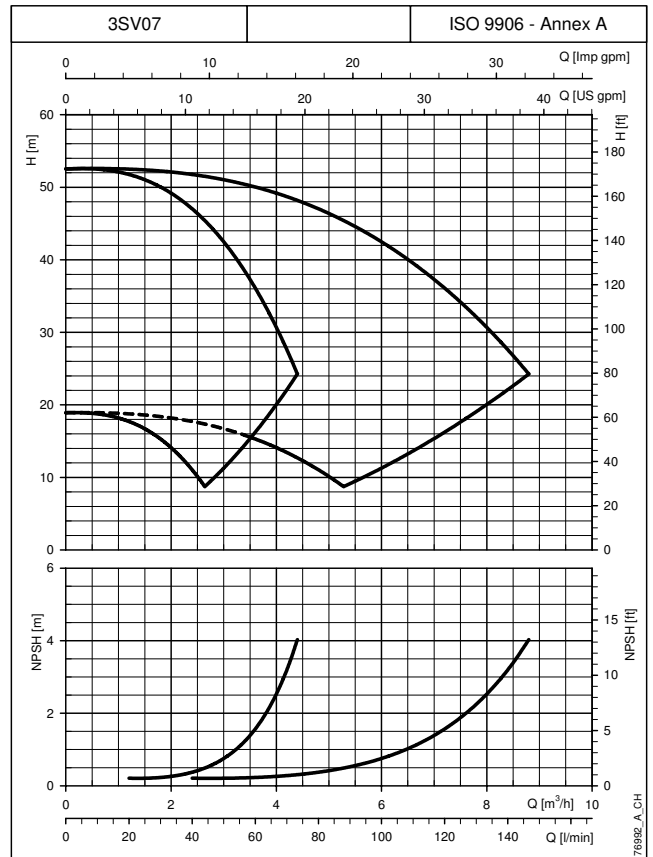
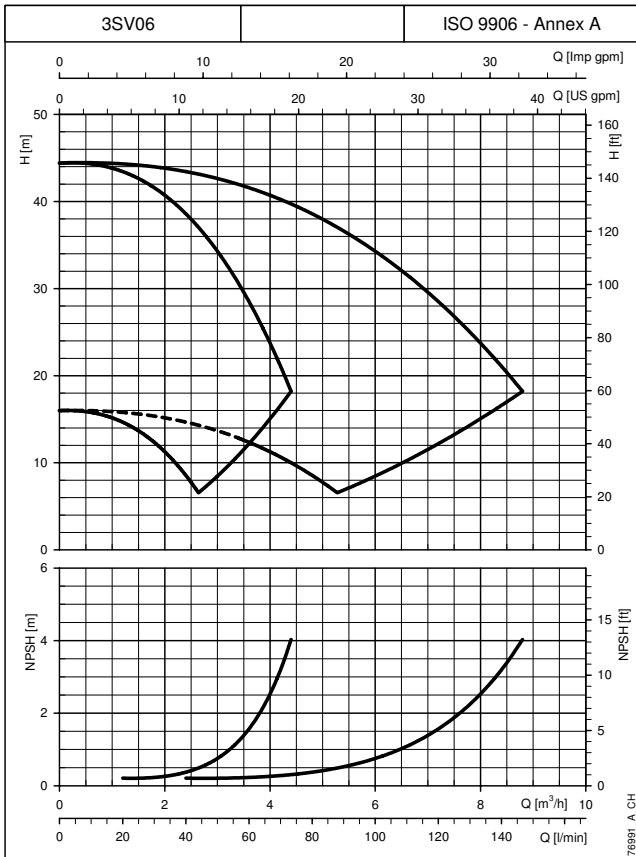

The performance curves do not take into account flow resistance in the valves and piping.
The curves show the performance with one and two pumps running.
These performances are valid for liquids with density $\rho = 1.0 \text{ Kg/dm}^3$ and kinematic viscosity $\nu = 1 \text{ mm}^2/\text{s}$.
The declared NPSH values are laboratory values: for practical use we recommend increasing these values by 0,5 m.

CURVES

TWO-PUMP BOOSTER SETS OPERATING CHARACTERISTICS AT 30..50 Hz

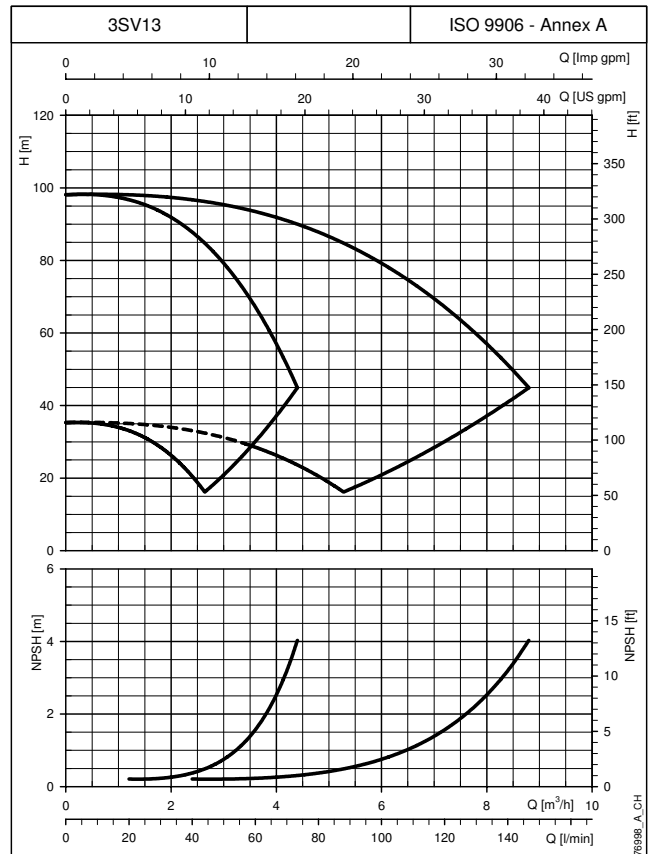
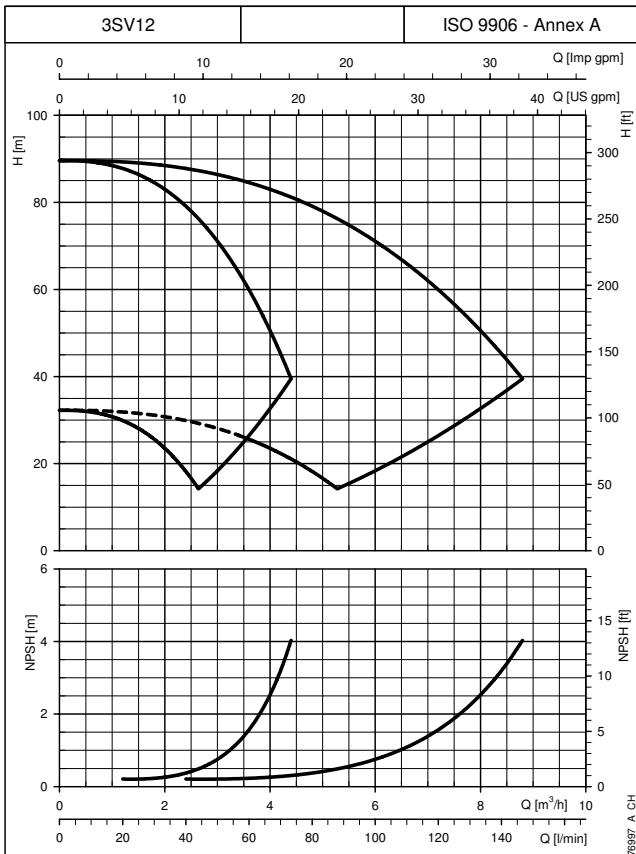
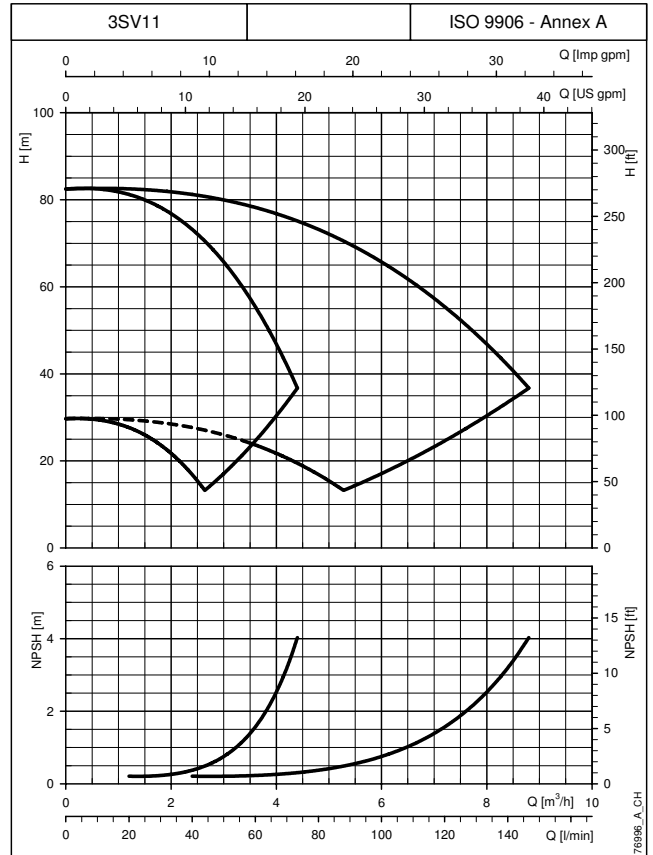
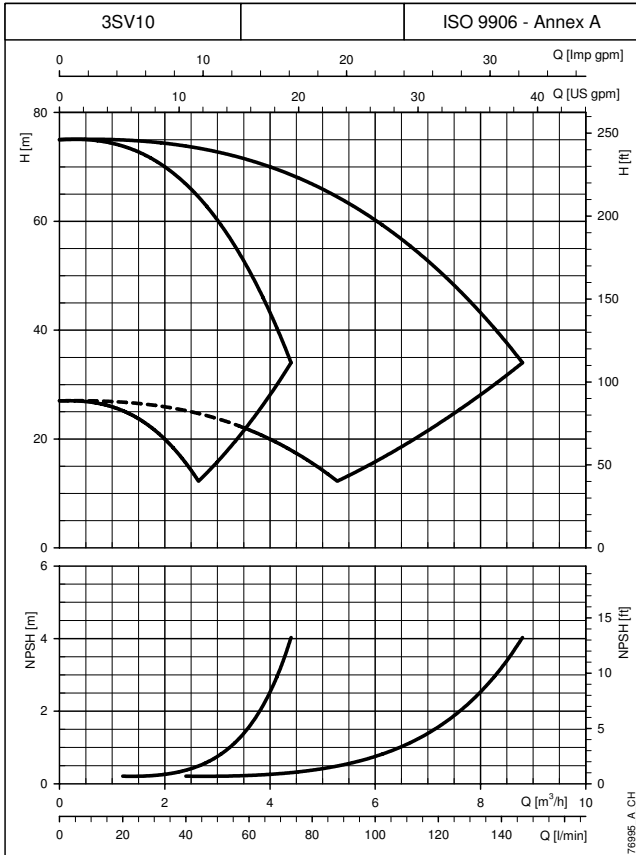

CURVES

The performance curves do not take into account flow resistance in the valves and piping.
 The curves show the performance with one and two pumps running.
 These performances are valid for liquids with density $\rho = 1.0 \text{ Kg/dm}^3$ and kinematic viscosity $\nu = 1 \text{ mm}^2/\text{s}$.
 The declared NPSH values are laboratory values: for practical use we recommend increasing these values by 0,5 m.

TWO-PUMP BOOSTER SETS OPERATING CHARACTERISTICS AT 30..50 Hz

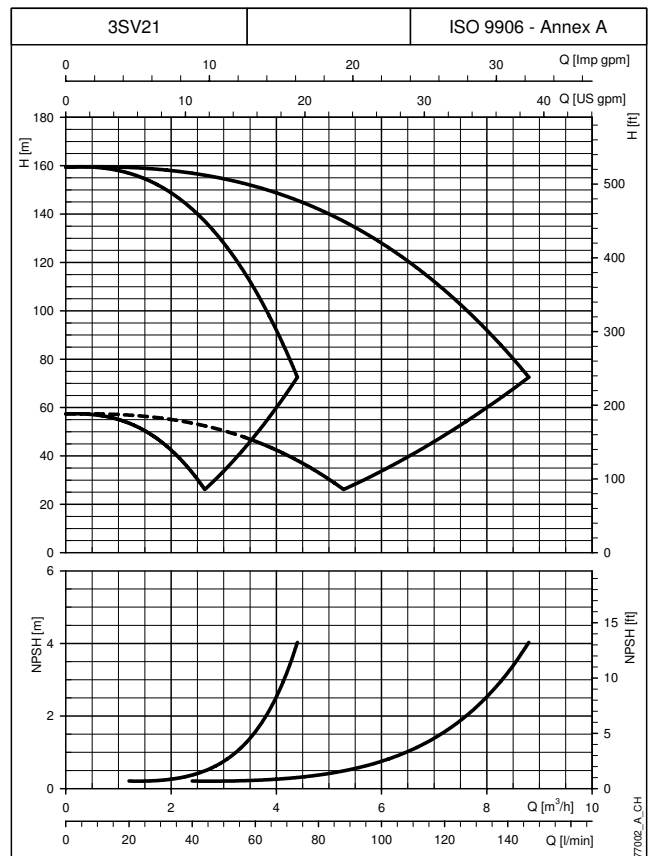
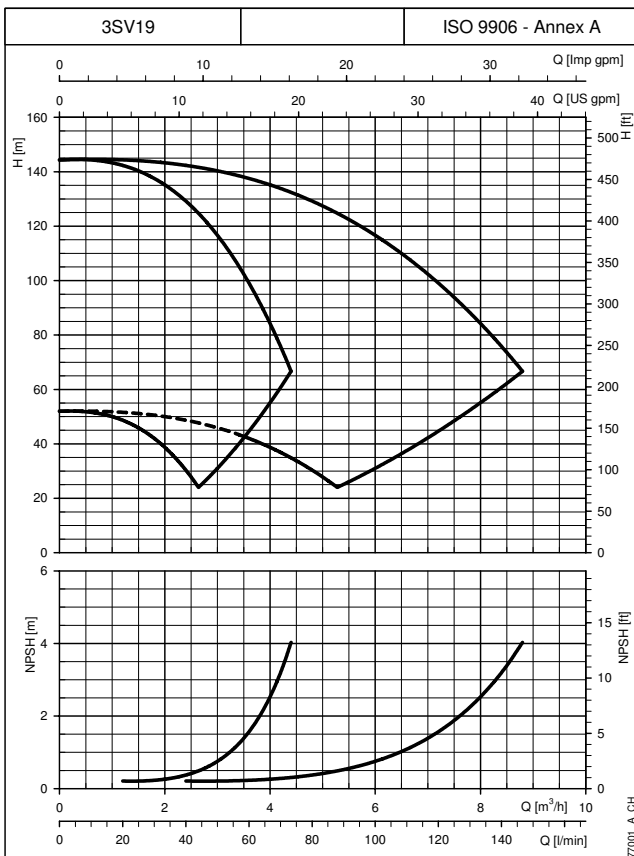
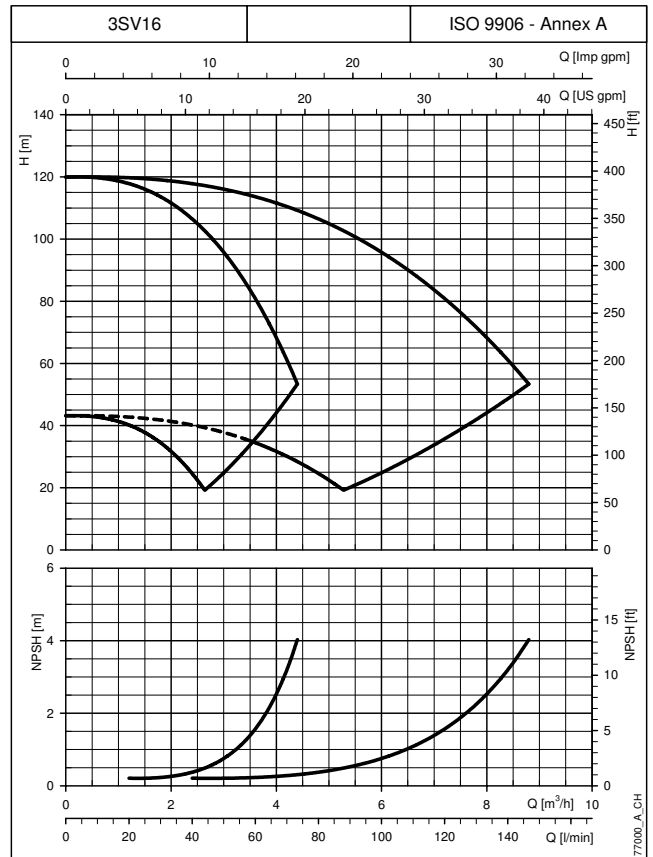
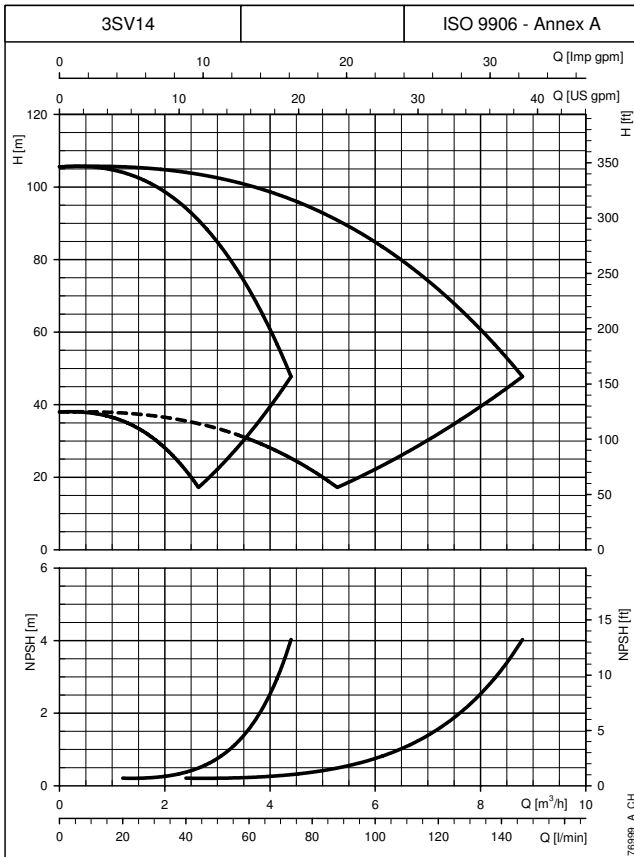

The performance curves do not take into account flow resistance in the valves and piping.
The curves show the performance with one and two pumps running.
These performances are valid for liquids with density $\rho = 1.0 \text{ Kg/dm}^3$ and kinematic viscosity $\nu = 1 \text{ mm}^2/\text{s}$.
The declared NPSH values are laboratory values: for practical use we recommend increasing these values by 0,5 m.

CURVES

**TWO-PUMP BOOSTER SETS
OPERATING CHARACTERISTICS AT 30..50 Hz**

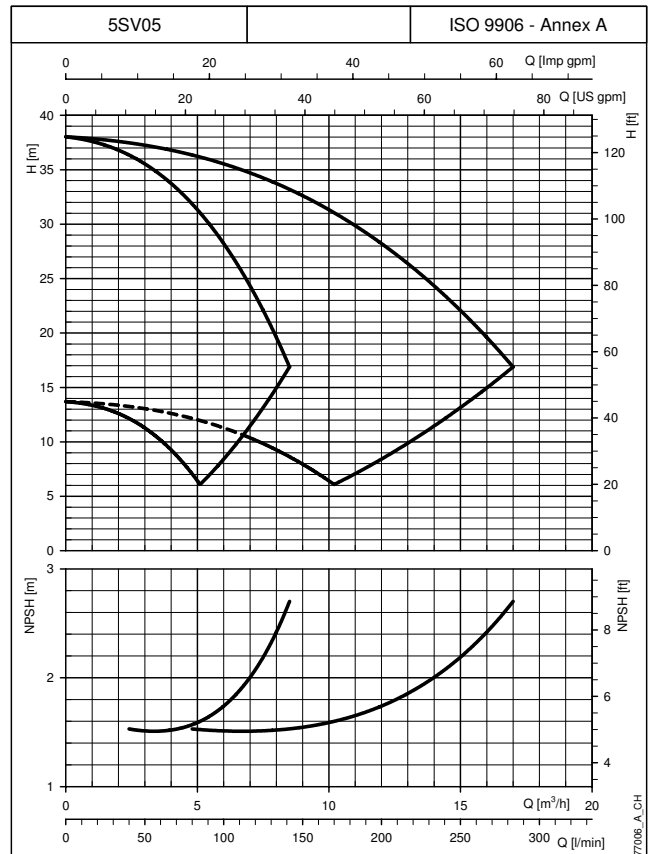
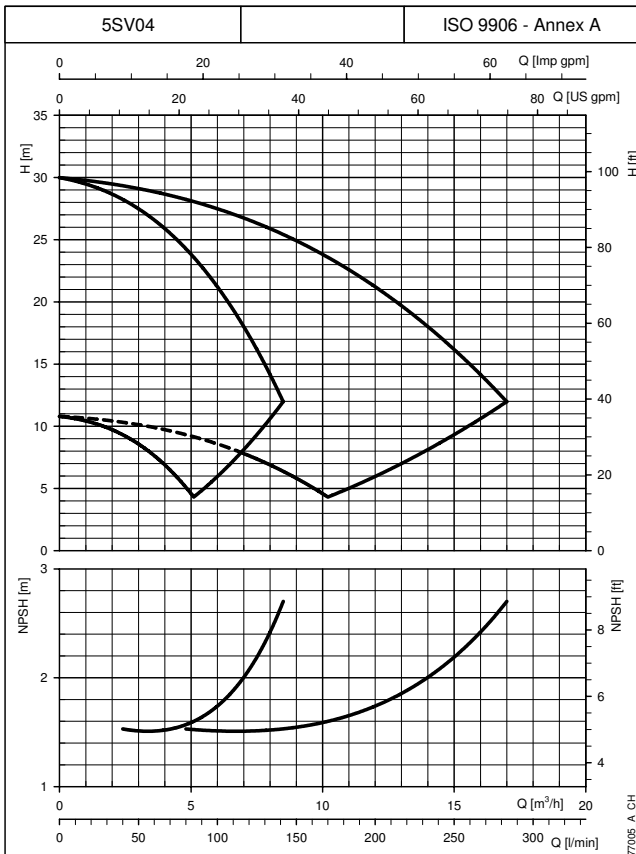
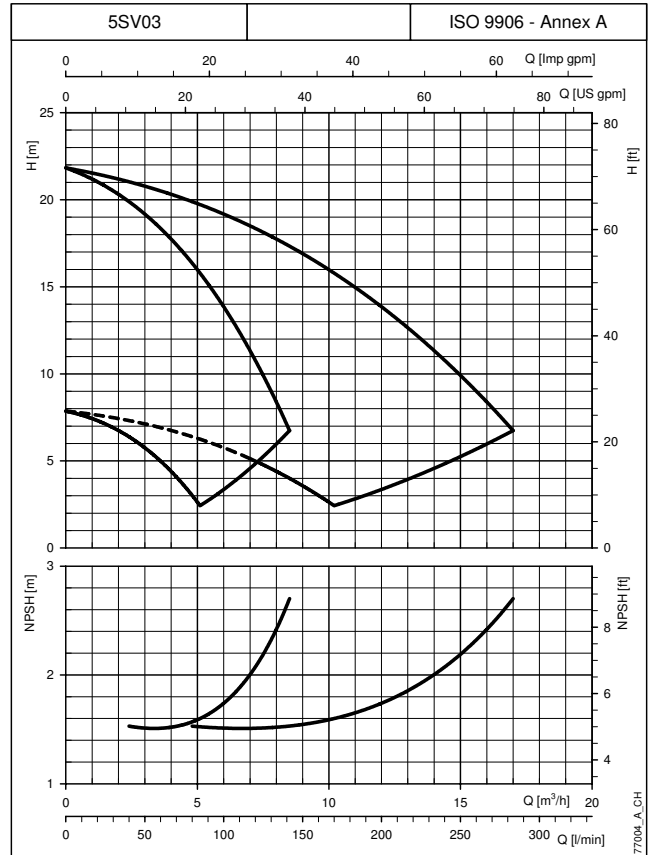
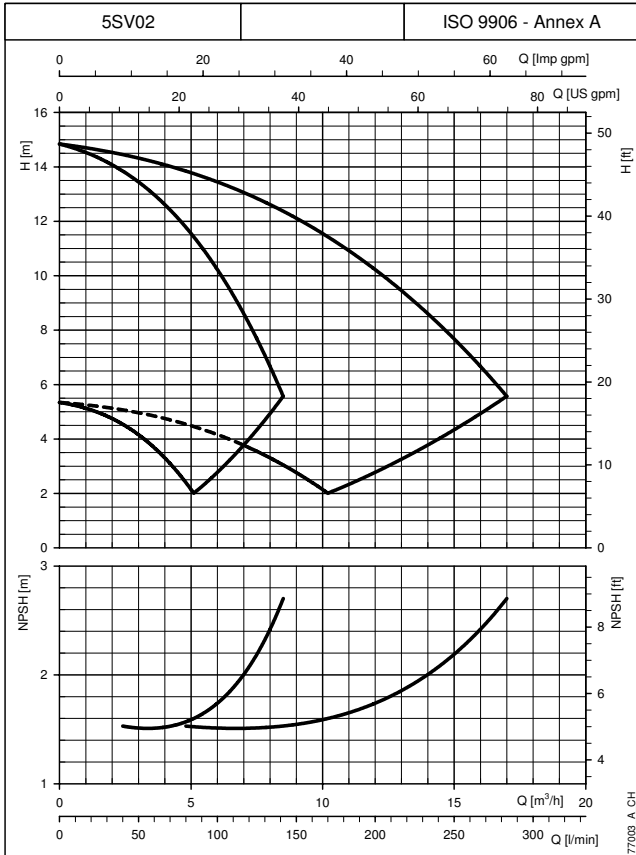

CURVES

The performance curves do not take into account flow resistance in the valves and piping.
The curves show the performance with one and two pumps running.
These performances are valid for liquids with density $\rho = 1.0 \text{ Kg/dm}^3$ and kinematic viscosity $\nu = 1 \text{ mm}^2/\text{s}$.
The declared NPSH values are laboratory values: for practical use we recommend increasing these values by 0,5 m.

TWO-PUMP BOOSTER SETS OPERATING CHARACTERISTICS AT 30..50 Hz

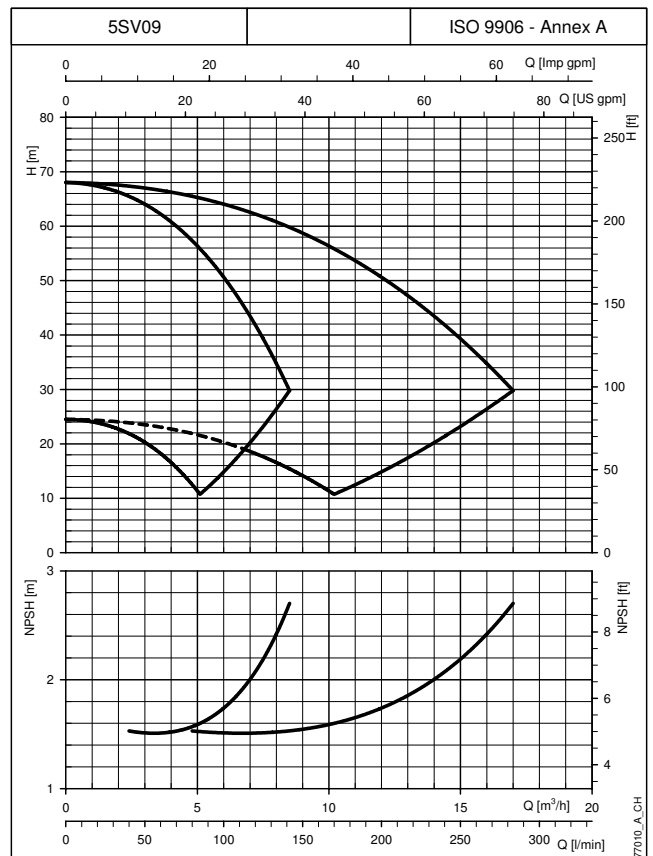
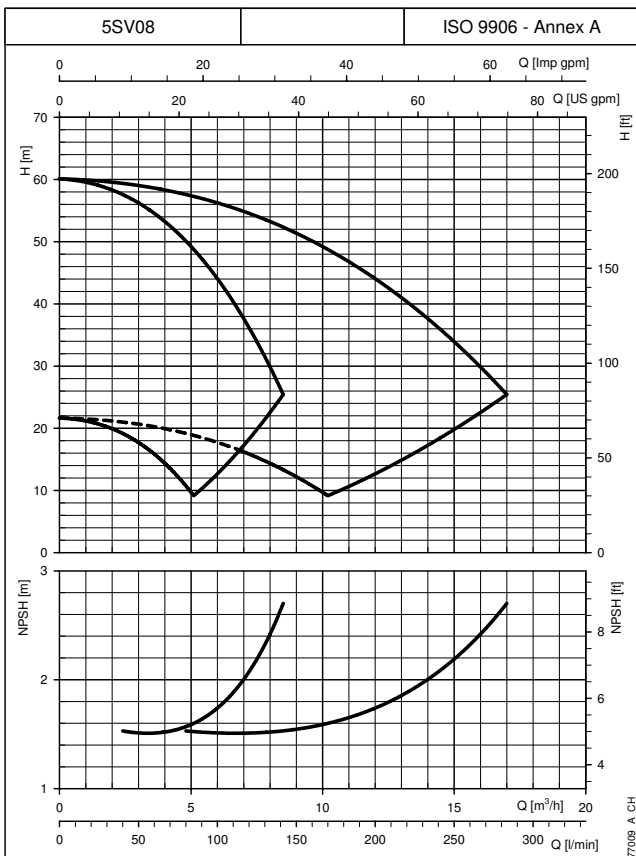
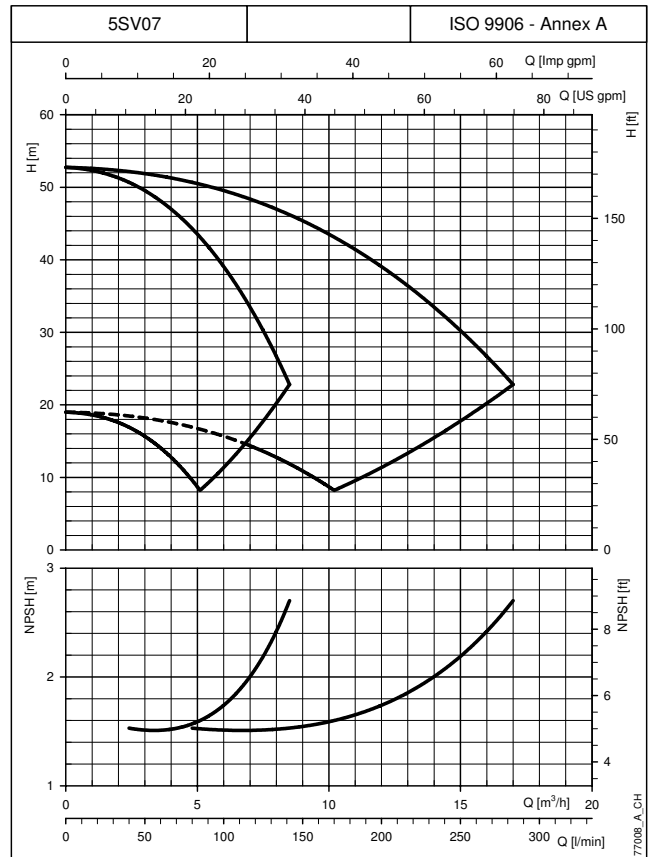
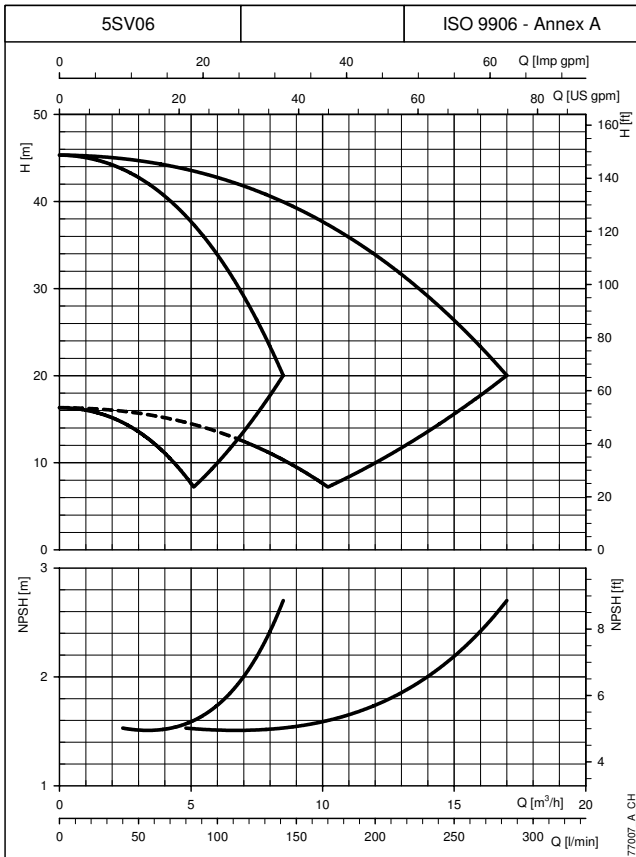

The performance curves do not take into account flow resistance in the valves and piping.
 The curves show the performance with one and two pumps running.
 These performances are valid for liquids with density $\rho = 1.0 \text{ Kg/dm}^3$ and kinematic viscosity $\nu = 1 \text{ mm}^2/\text{s}$.
 The declared NPSH values are laboratory values: for practical use we recommend increasing these values by 0,5 m.

CURVES

**TWO-PUMP BOOSTER SETS
OPERATING CHARACTERISTICS AT 30..50 Hz**

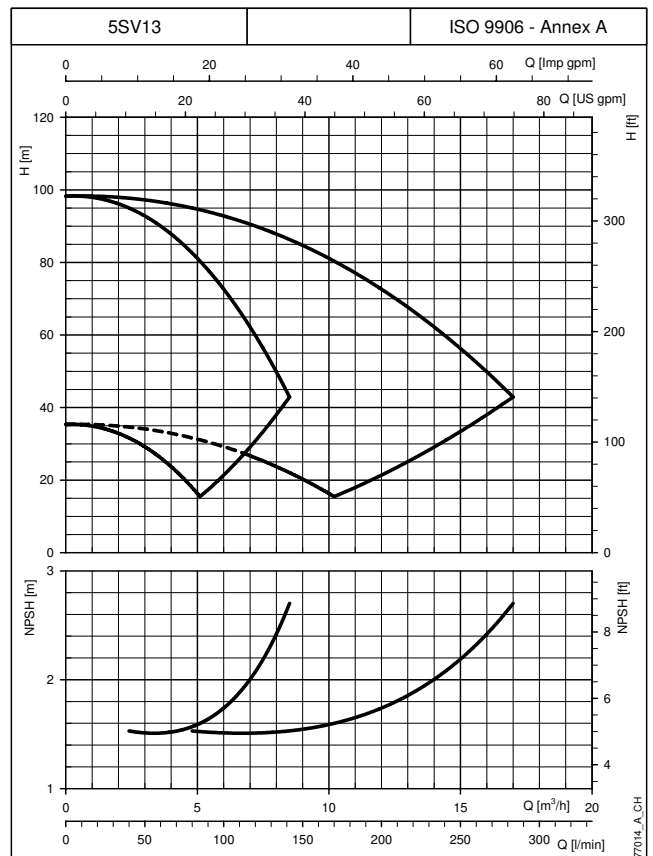
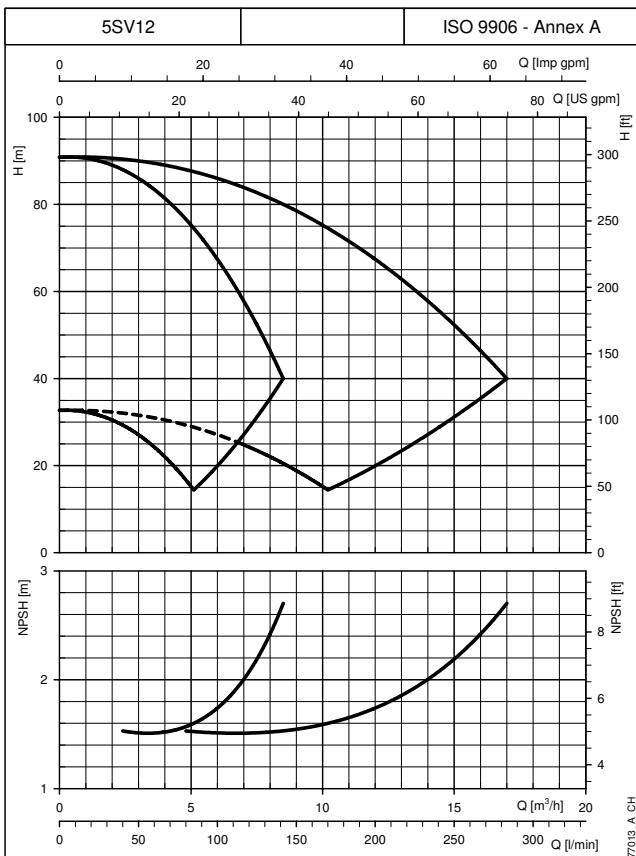
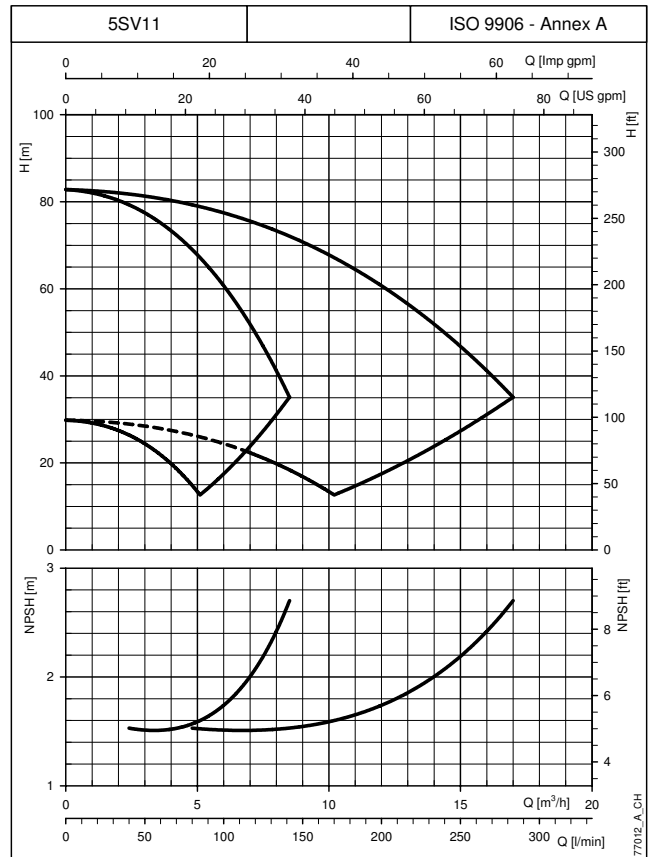
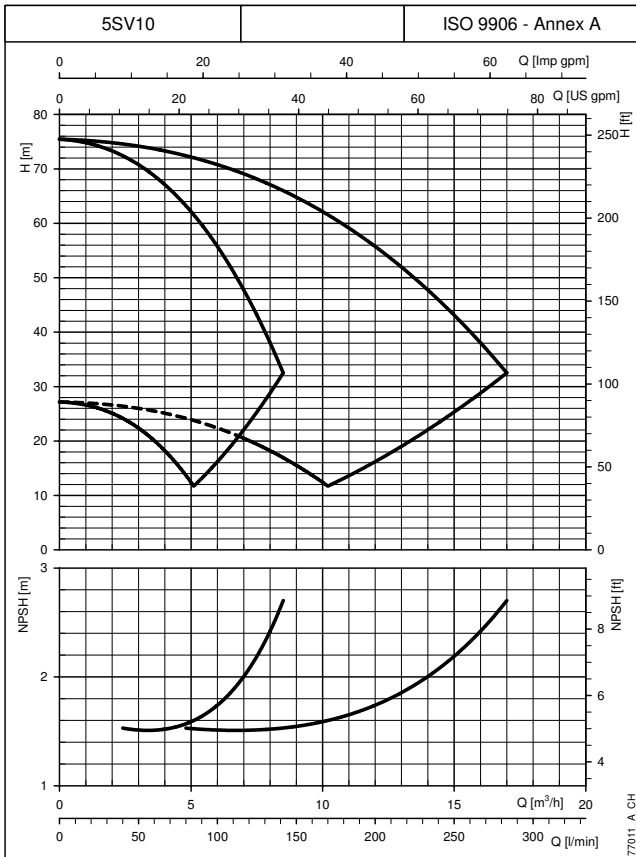

CURVES

The performance curves do not take into account flow resistance in the valves and piping.
The curves show the performance with one and two pumps running.
These performances are valid for liquids with density $\rho = 1.0 \text{ Kg/dm}^3$ and kinematic viscosity $\nu = 1 \text{ mm}^2/\text{s}$.
The declared NPSH values are laboratory values: for practical use we recommend increasing these values by 0,5 m.

**TWO-PUMP BOOSTER SETS
OPERATING CHARACTERISTICS AT 30..50 Hz**

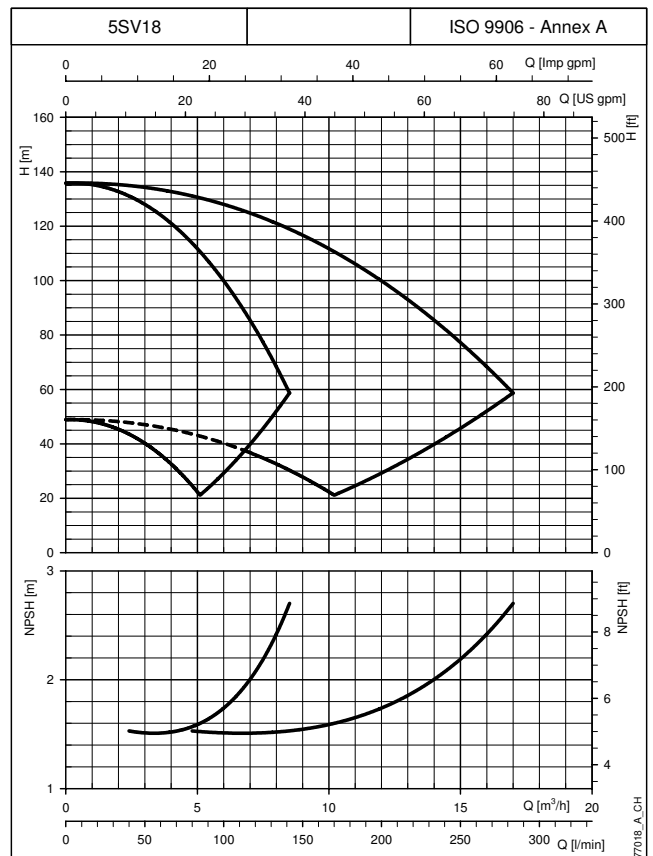
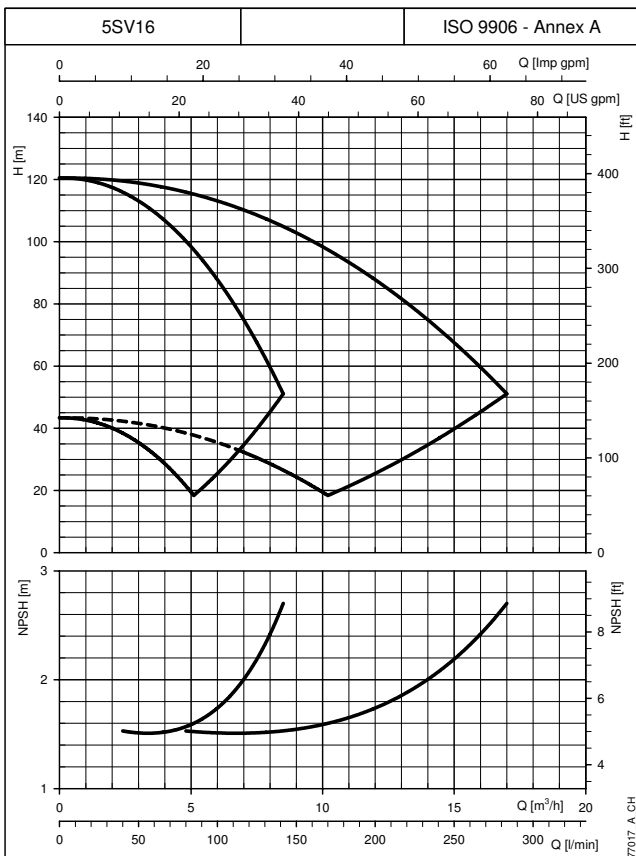
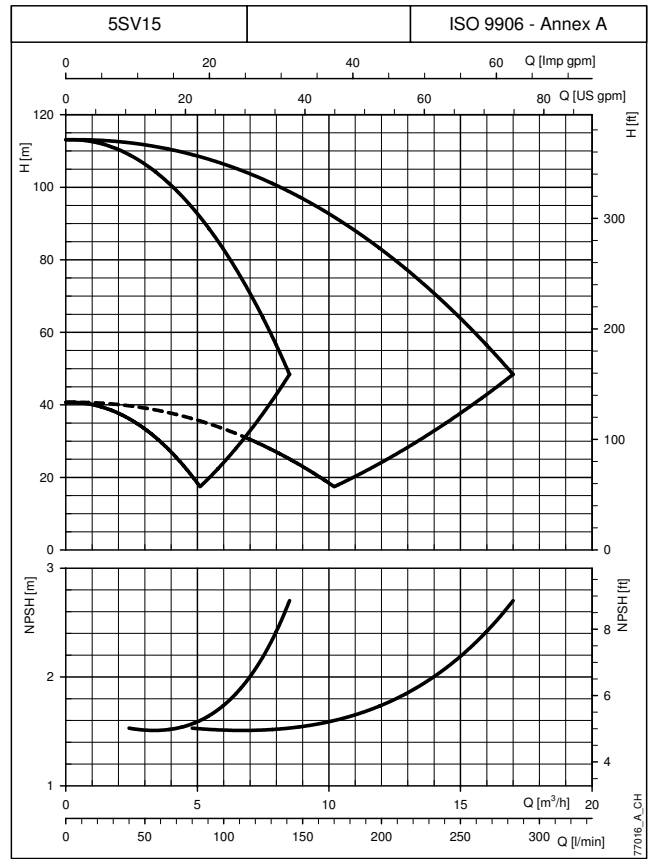
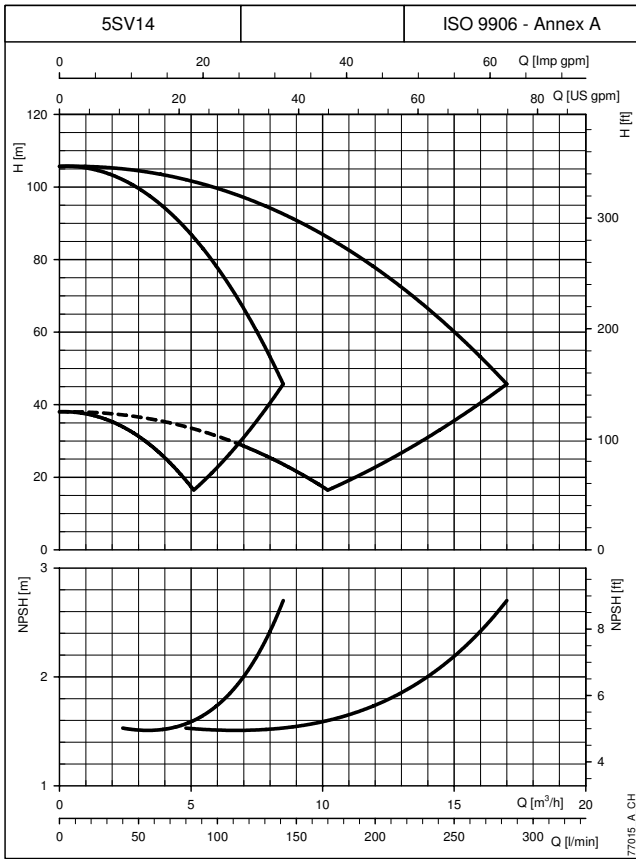

The performance curves do not take into account flow resistance in the valves and piping.
 The curves show the performance with one and two pumps running.
 These performances are valid for liquids with density $\rho = 1.0\ Kg/dm^3$ and kinematic viscosity $\nu = 1\ mm^2/s$.
 The declared NPSH values are laboratory values: for practical use we recommend increasing these values by 0,5 m.



TWO-PUMP BOOSTER SETS OPERATING CHARACTERISTICS AT 30..50 Hz

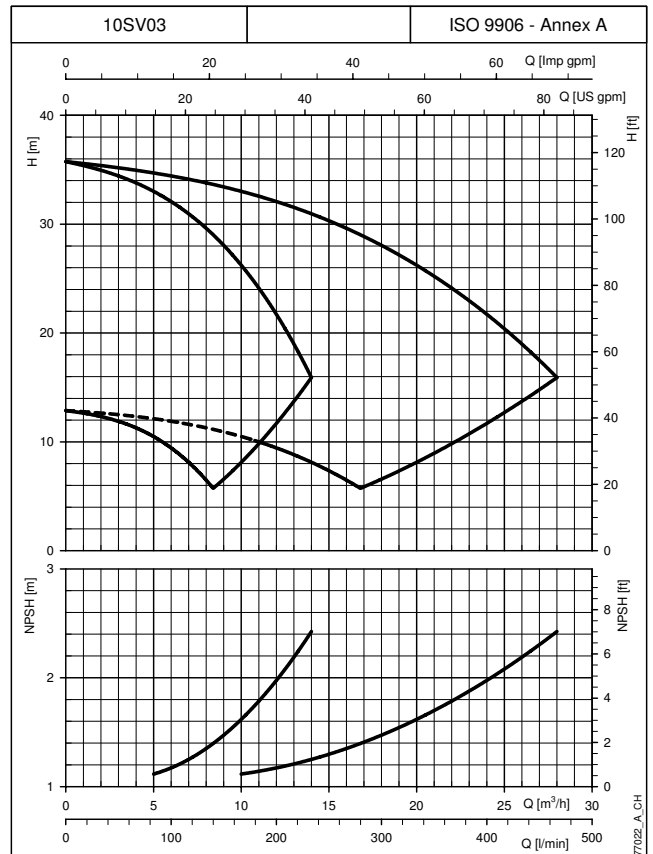
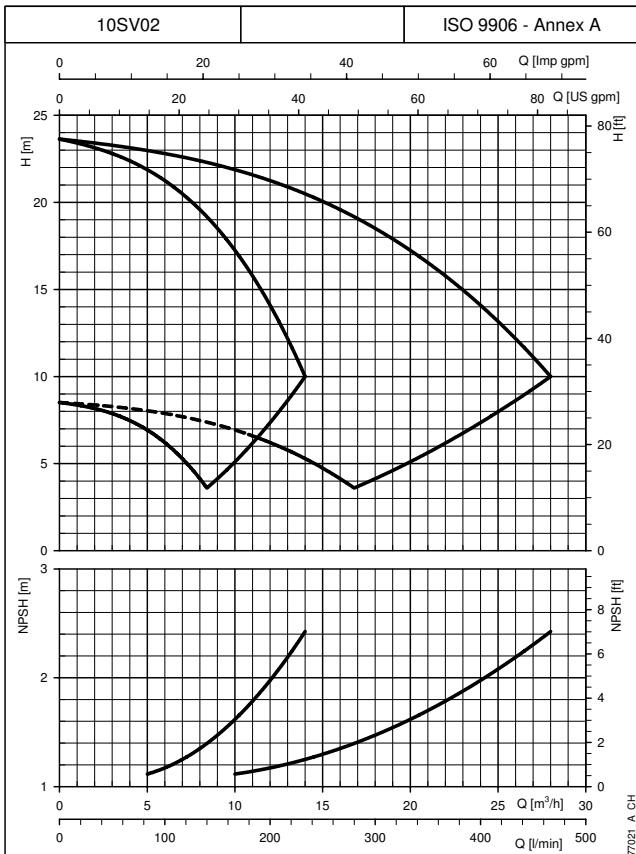
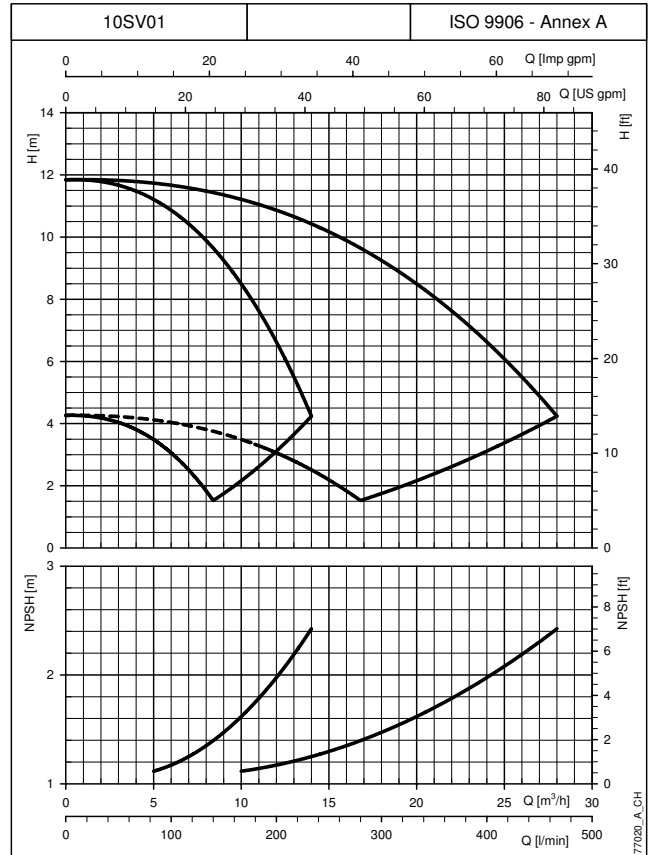
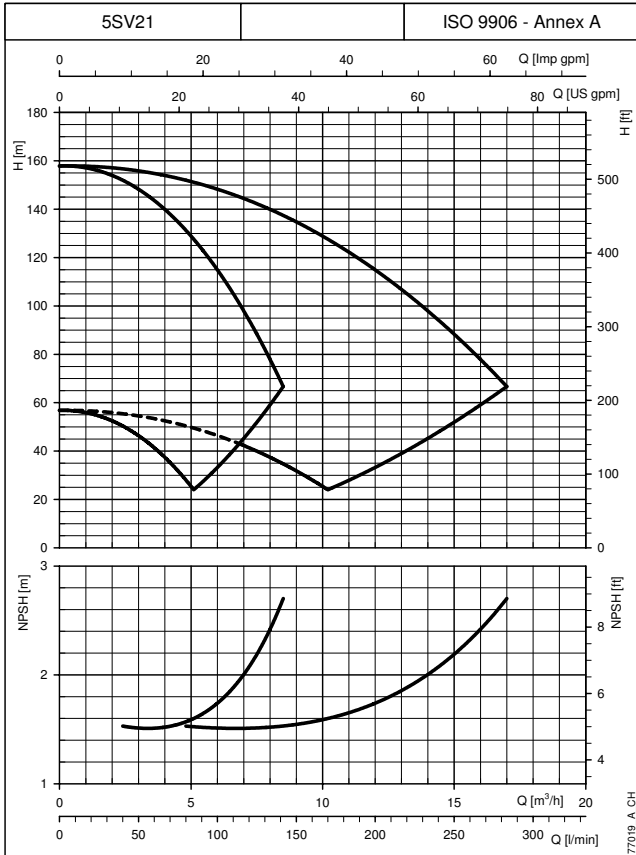

CURVES

The performance curves do not take into account flow resistance in the valves and piping.
The curves show the performance with one and two pumps running.
These performances are valid for liquids with density $\rho = 1.0 \text{ Kg/dm}^3$ and kinematic viscosity $\nu = 1 \text{ mm}^2/\text{s}$.
The declared NPSH values are laboratory values: for practical use we recommend increasing these values by 0,5 m.

TWO-PUMP BOOSTER SETS OPERATING CHARACTERISTICS AT 30..50 Hz

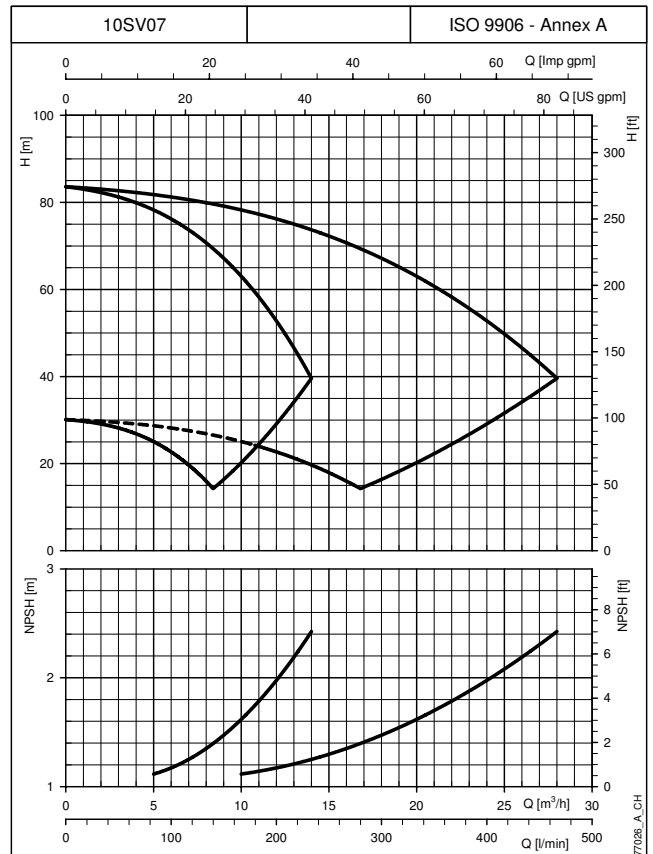
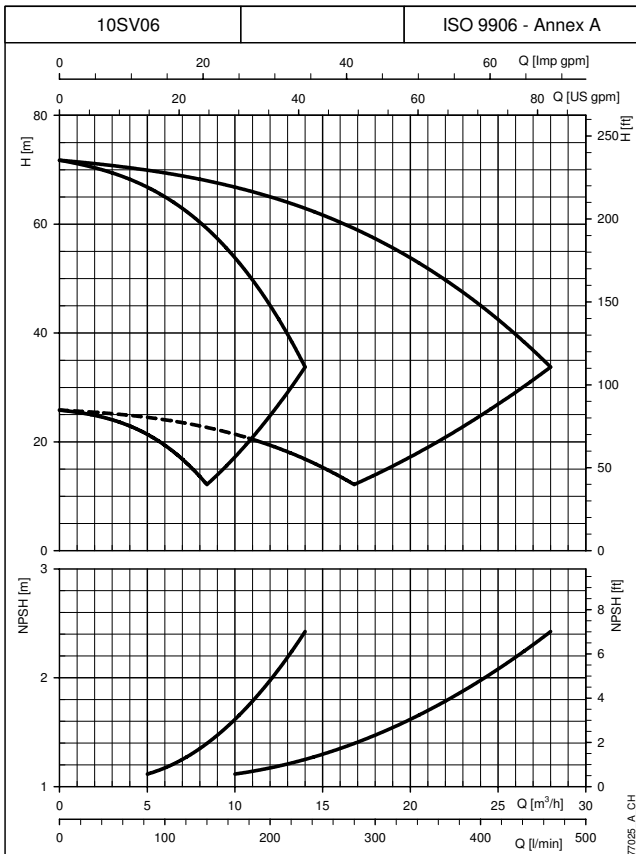
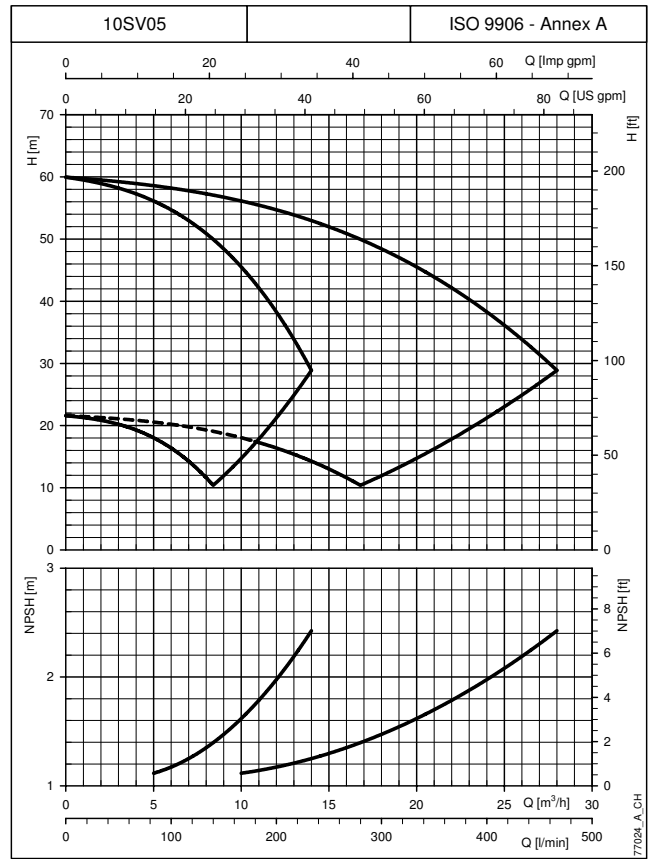
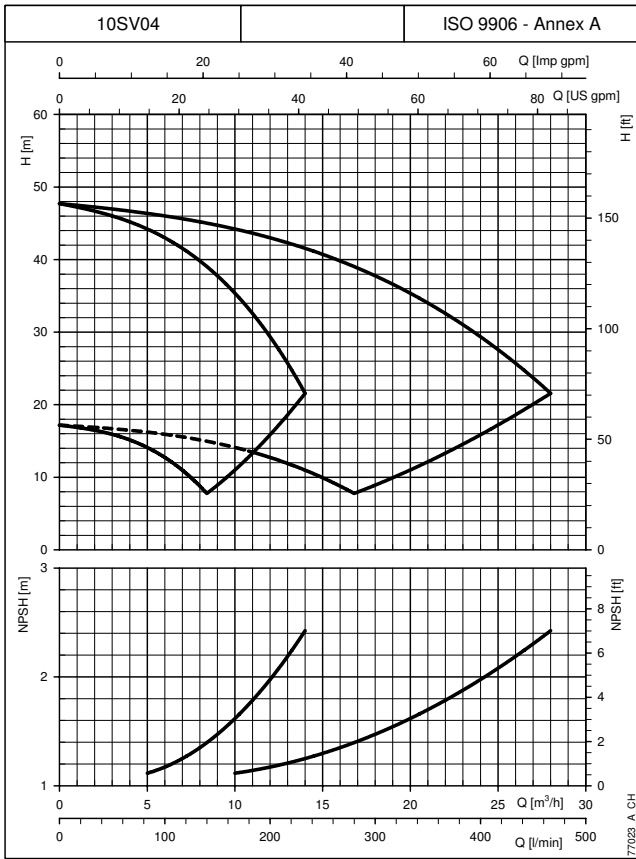

The performance curves do not take into account flow resistance in the valves and piping.
 The curves show the performance with one and two pumps running.
 These performances are valid for liquids with density $\rho = 1.0 \text{ Kg/dm}^3$ and kinematic viscosity $\nu = 1 \text{ mm}^2/\text{s}$.
 The declared NPSH values are laboratory values: for practical use we recommend increasing these values by 0,5 m.

CURVES

TWO-PUMP BOOSTER SETS OPERATING CHARACTERISTICS AT 30..50 Hz

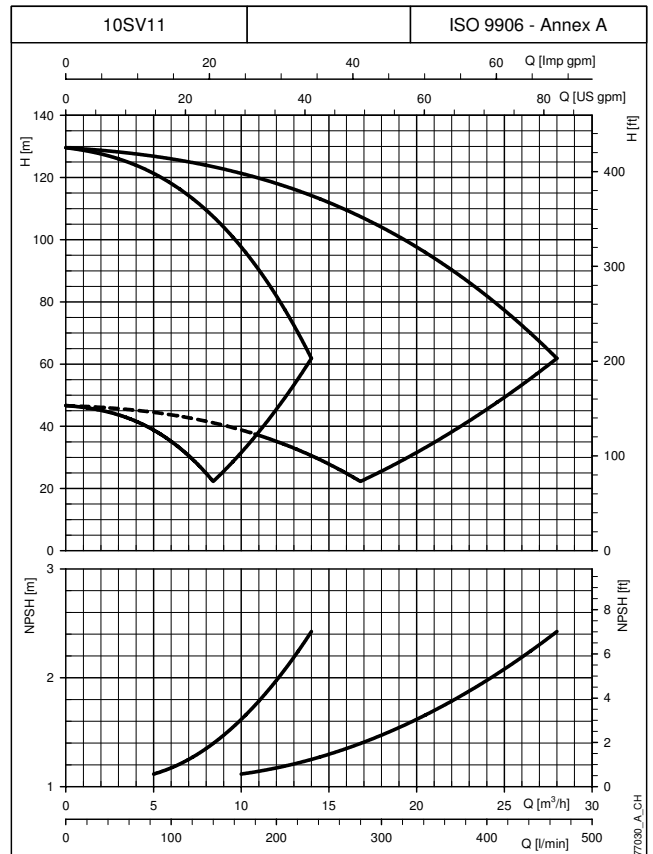
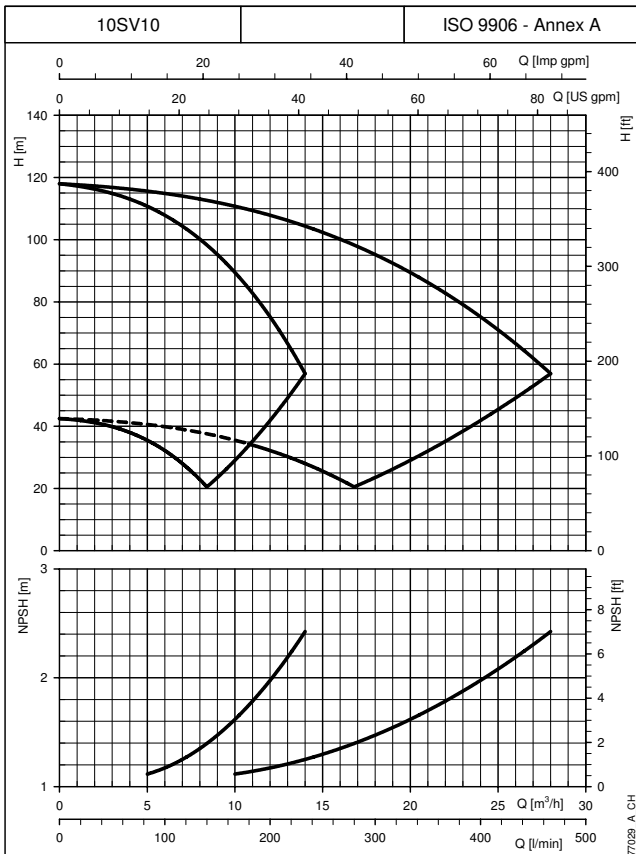
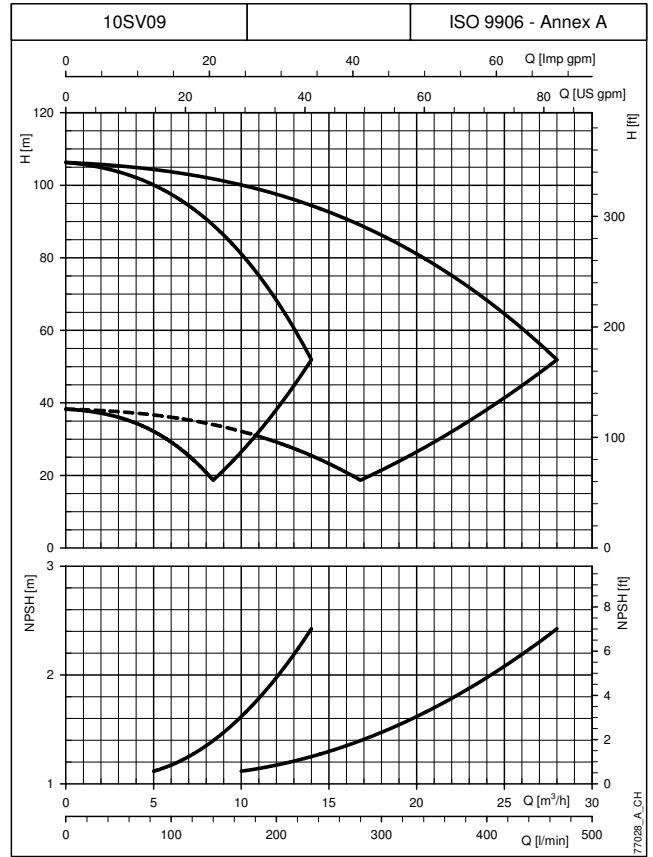
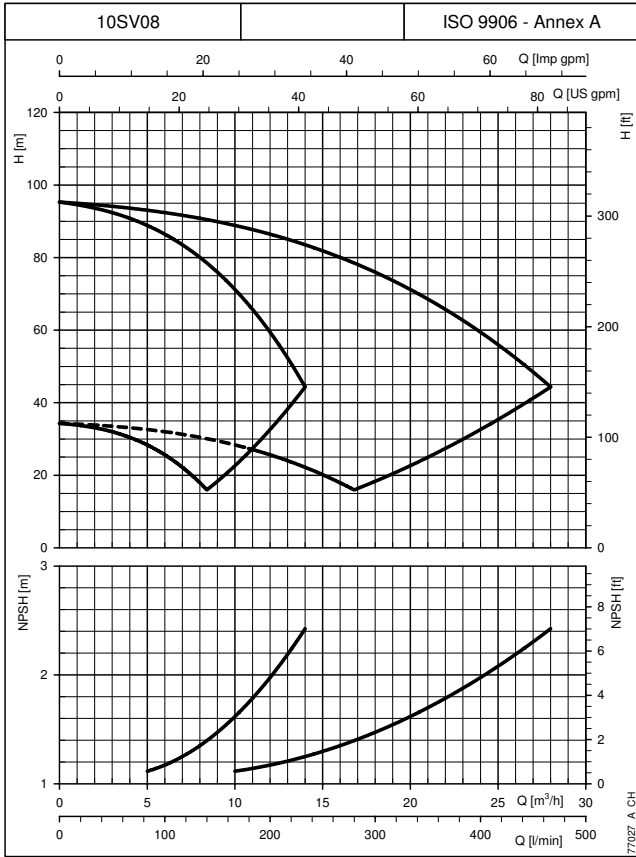

CURVES

The performance curves do not take into account flow resistance in the valves and piping.
 The curves show the performance with one and two pumps running.
 These performances are valid for liquids with density $\rho = 1.0 \text{ Kg/dm}^3$ and kinematic viscosity $\nu = 1 \text{ mm}^2/\text{s}$.
 The declared NPSH values are laboratory values: for practical use we recommend increasing these values by 0,5 m.

TWO-PUMP BOOSTER SETS OPERATING CHARACTERISTICS AT 30..50 Hz

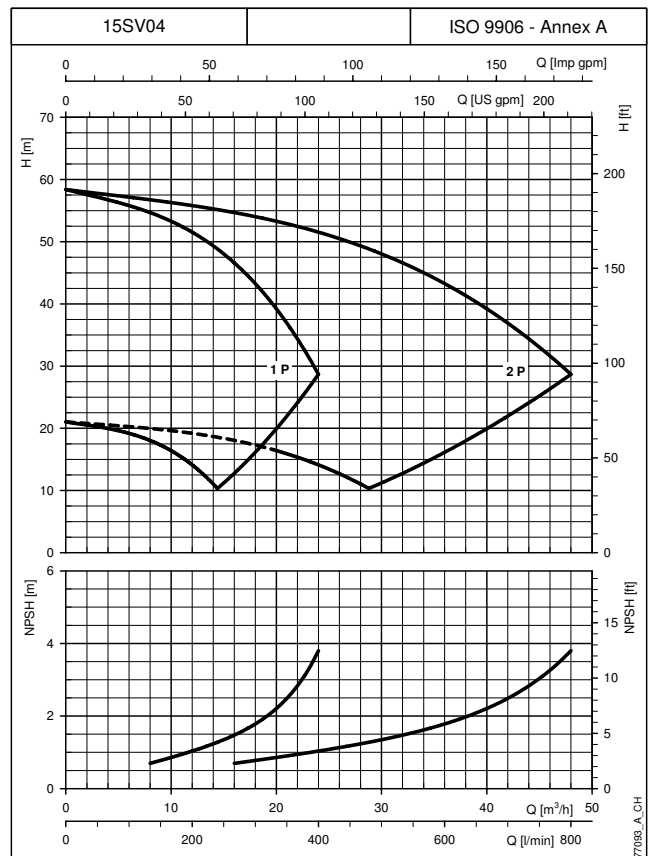
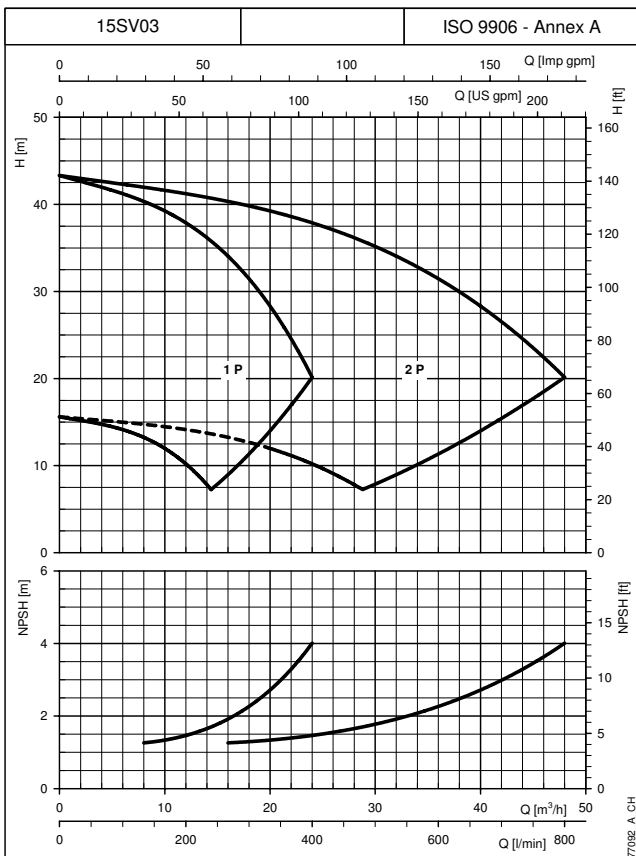
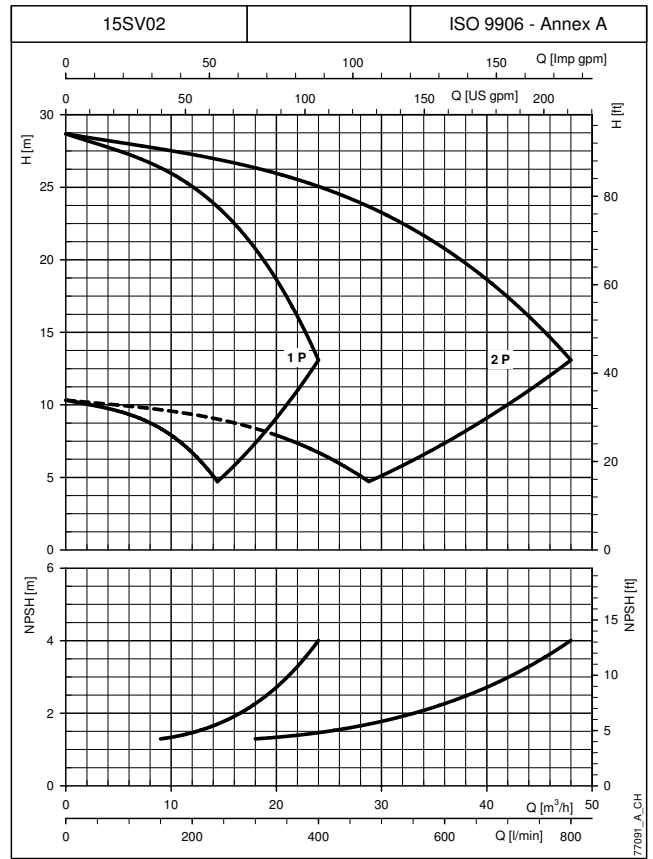
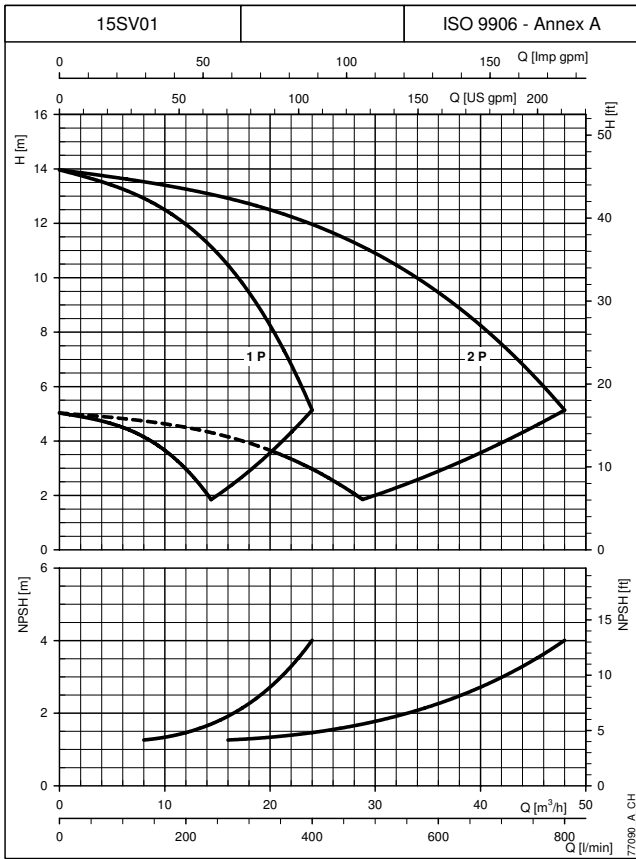

The performance curves do not take into account flow resistance in the valves and piping.
 The curves show the performance with one and two pumps running.
 These performances are valid for liquids with density $\rho = 1.0 \text{ Kg/dm}^3$ and kinematic viscosity $\nu = 1 \text{ mm}^2/\text{s}$.
 The declared NPSH values are laboratory values: for practical use we recommend increasing these values by 0,5 m.

CURVES

TWO-PUMP BOOSTER SETS OPERATING CHARACTERISTICS AT 30..50 Hz

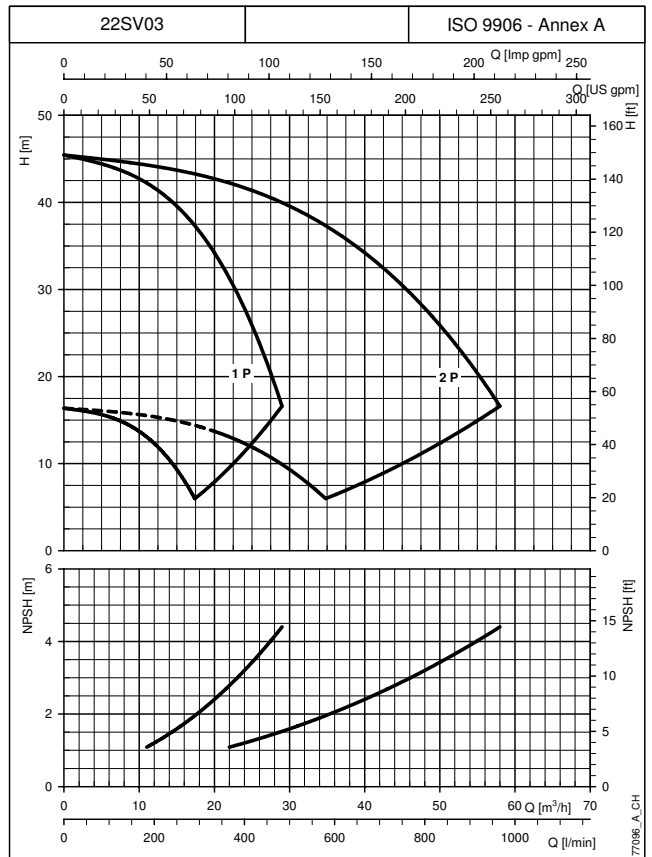
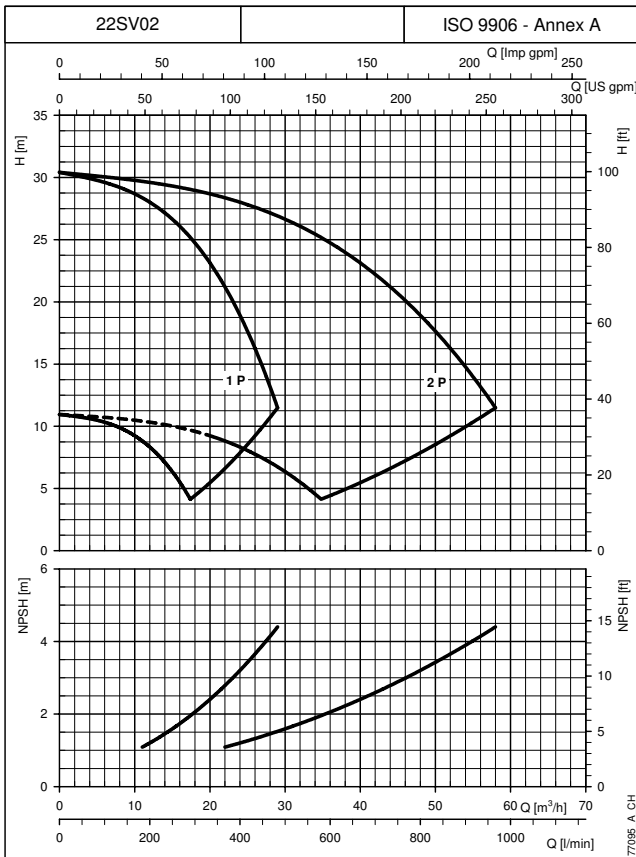
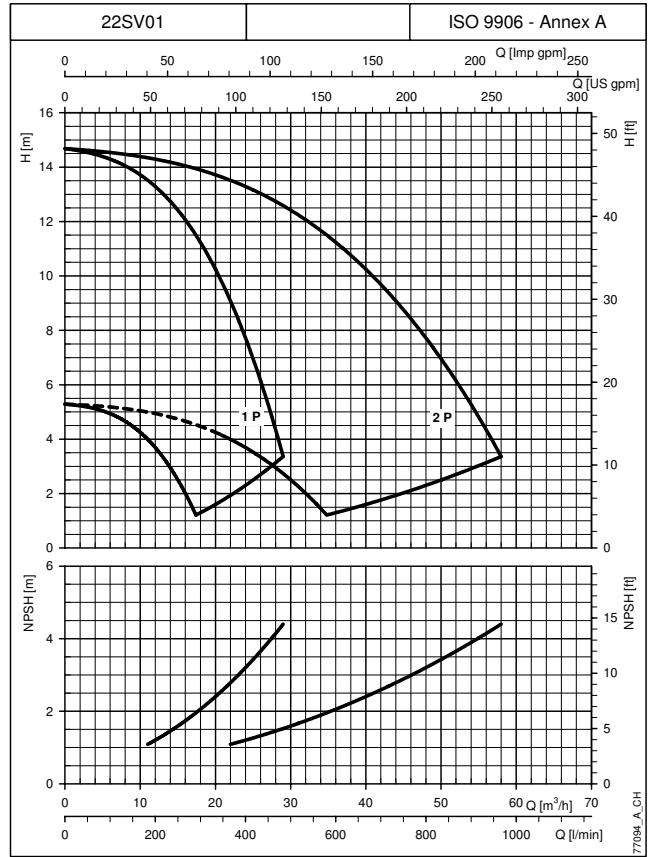
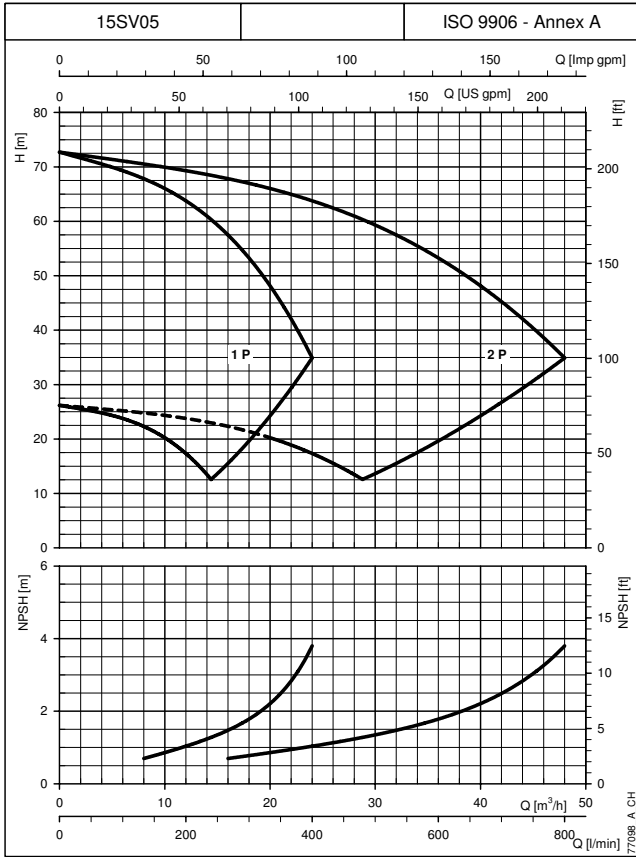

CURVES

The performance curves do not take into account flow resistance in the valves and piping.
 The curves show the performance with one and two pumps running.
 These performances are valid for liquids with density $\rho = 1.0 \text{ Kg/dm}^3$ and kinematic viscosity $\nu = 1 \text{ mm}^2/\text{s}$.
 The declared NPSH values are laboratory values: for practical use we recommend increasing these values by 0,5 m.

**TWO-PUMP BOOSTER SETS
OPERATING CHARACTERISTICS AT 30..50 Hz**

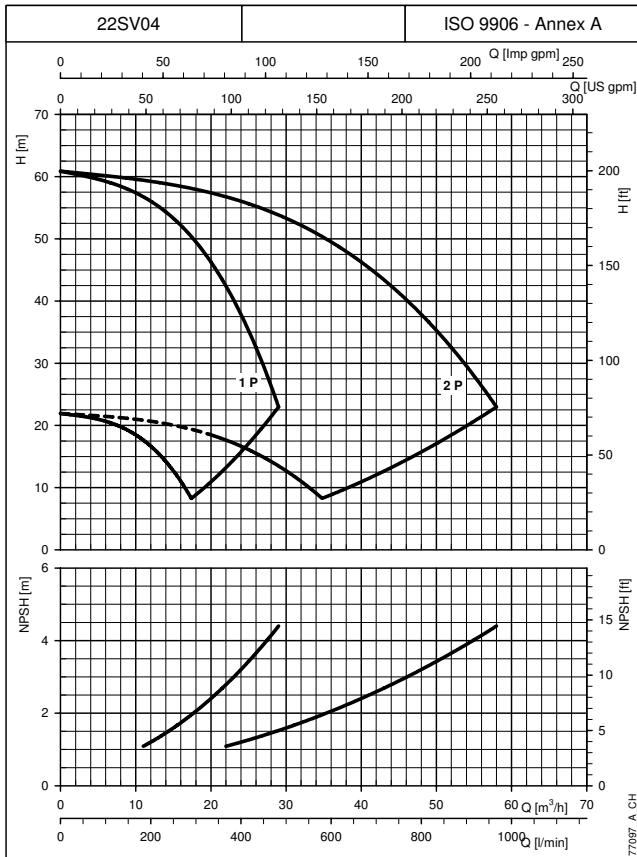

The performance curves do not take into account flow resistance in the valves and piping.
 The curves show the performance with one and two pumps running.
 These performances are valid for liquids with density $\rho = 1.0 \text{ Kg/dm}^3$ and kinematic viscosity $\nu = 1 \text{ mm}^2/\text{s}$.
 The declared NPSH values are laboratory values: for practical use we recommend increasing these values by 0,5 m.

TECHNICAL APPENDIX

WATER REQUIREMENTS IN CIVIL USERS

Determination of the water requirement depends on the type of users and contemporaneity factor. The calculation may be subject to regulations, standards or customs that may vary from country to country. The calculation method shown below is an example based on practical experience, designed to provide a reference value and not a substitute for detailed analytical calculation.

Water requirements in condominiums

The **consumption table** shows the maximum values for each delivery point, depending on the plumbing amenities.

MAXIMUM CONSUMPTION FOR EACH DELIVERY POINT

TYPE	CONSUMPTION (l/min)
Sink	9
Dishwasher	10
Washing machine	12
Shower	12
Bathtub	15
Washbasin	6
Bidet	6
Flush tank WC	6
Controlled flushing system WC	90

G-at-cm_a_th

The **sum of the water consumption values** of each delivery point determines the maximum theoretical requirement, which must be reduced according to the **contemporaneity coefficient**, because in actual fact the delivery points are never used all together.

$f = \frac{1}{\sqrt{(0,857 \times Nr \times Na)}}$	Coefficient for apartments with one bathroom and flush tank WC
$f = \frac{1}{\sqrt{(0,857 \times Nr \times Na)}}$	Coefficient for apartments with one bathroom and controlled flushing system WC
$f = \frac{1,03}{\sqrt{(0,545 \times Nr \times Na)}}$	Coefficient for apartments with two bathrooms and flush tank WC
$f = \frac{0,8}{\sqrt{(0,727 \times Nr \times Na)}}$	Coefficient for apartments with two bathrooms and controlled flushing system WC
f= coefficient; Nr= number of delivery points; Na= number of apartments	

The **table of water requirements in civil users** shows the maximum contemporaneity flow-rate values based on the **number of apartments** and the type of WC for apartments with one bathroom and two bathrooms. As regards apartments with one bathroom, 7 drawing points have been taken into consideration, while 11 points have been considered for apartments with two bathrooms. If the number of drawing points or apartments is different, use the formulas to **calculate** the requirement.

TABLE OF WATER REQUIREMENTS IN CIVIL USERS

NUMBER OF APARTMENTS	WITH FLUSH TANK WC		WITH CONTROLLED FLUSHING SYSTEM WC	
	1	2	1	2
	FLOW RATE (l/min)			
1	32	40	60	79
2	45	56	85	111
3	55	68	105	136
4	63	79	121	157
5	71	88	135	176
6	78	97	148	193
7	84	105	160	208
8	90	112	171	223
9	95	119	181	236
10	100	125	191	249
11	105	131	200	261
12	110	137	209	273
13	114	143	218	284
14	119	148	226	295
15	123	153	234	305
16	127	158	242	315
17	131	163	249	325
18	134	168	256	334
19	138	172	263	343
20	142	177	270	352
21	145	181	277	361
22	149	185	283	369
23	152	190	290	378
24	155	194	296	386
25	158	198	302	394
26	162	202	308	401
27	165	205	314	409
28	168	209	320	417
29	171	213	325	424
30	174	217	331	431
35	187	234	357	466
40	200	250	382	498
45	213	265	405	528
50	224	280	427	557
55	235	293	448	584
60	245	306	468	610
65	255	319	487	635
70	265	331	506	659
75	274	342	523	682
80	283	354	540	704
85	292	364	557	726
90	301	375	573	747
95	309	385	589	767
100	317	395	604	787
120	347	433	662	863
140	375	468	715	932
160	401	500	764	996
180	425	530	811	1056
200	448	559	854	1114

For seaside resorts, a flow rate increased by at least 20% must be considered.

G-at-fi_a_th

WATER REQUIREMENTS FOR COMMUNITY BUILDINGS

The requirements of buildings intended for specific uses, such as **offices, residential units, hotels, department stores, nursing homes** and so on, are different from those of condominiums, and both their global daily water consumption and the maximum contemporaneity flow rate are usually greater. The **diagram of water requirements for community buildings** shows the maximum contemporaneity flow rate of some types of communities, for guidance.

These requirements must be determined case by case with the utmost accuracy, using analytical calculation methods, according to particular needs and local provisions.

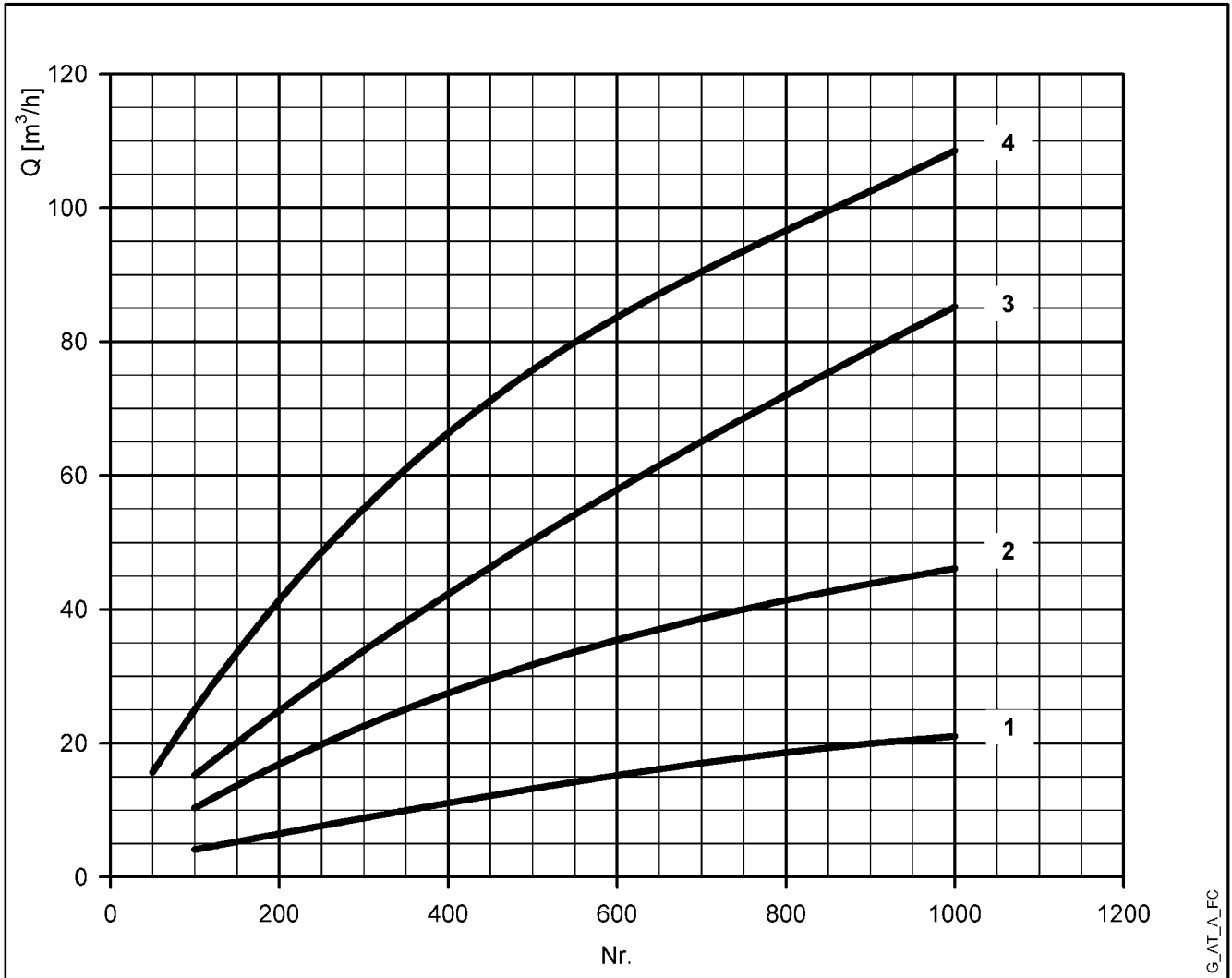

For seaside resorts, the flow rate must be increased by at least 20%.

- 1 = Offices (N. of people)
- 2 = Department stores (N. of people)
- 3 = Nursing homes (N. of beds)
- 4 = Hotels, residences (N. of beds)

USE OF BOOSTER SET

Water is usually delivered by public supply systems and the pressure is generally sufficient for the proper operation of the users' water and sanitary equipment.

When this pressure is not sufficient, booster sets are employed to increase water pressure and ensure an acceptable minimum value at the furthest points. Therefore, the water supply to a building, group of buildings or to a system in general can be considered satisfactory when all the user points can deliver the required quantity of water.

Set connection methods (intake side)

Water can be supplied to a booster set in two ways:

- 1 - By installing a water storage tank between the user's offtake and the booster set (indirect connection, fig. 7.1.1).
- 2 - By connecting the booster set directly between the user's offtake and the system (direct connection, fig. 7.1.1).

The indirect connection does not allow the water system pressure to be utilized. Therefore, it requires pumps with greater head.

The direct connection allows the water system pressure to be utilized, provided the pressure fluctuation (Δp) does not exceed 1 bar.

If it does, a pressure reducer must be installed for proper operation of the booster set.

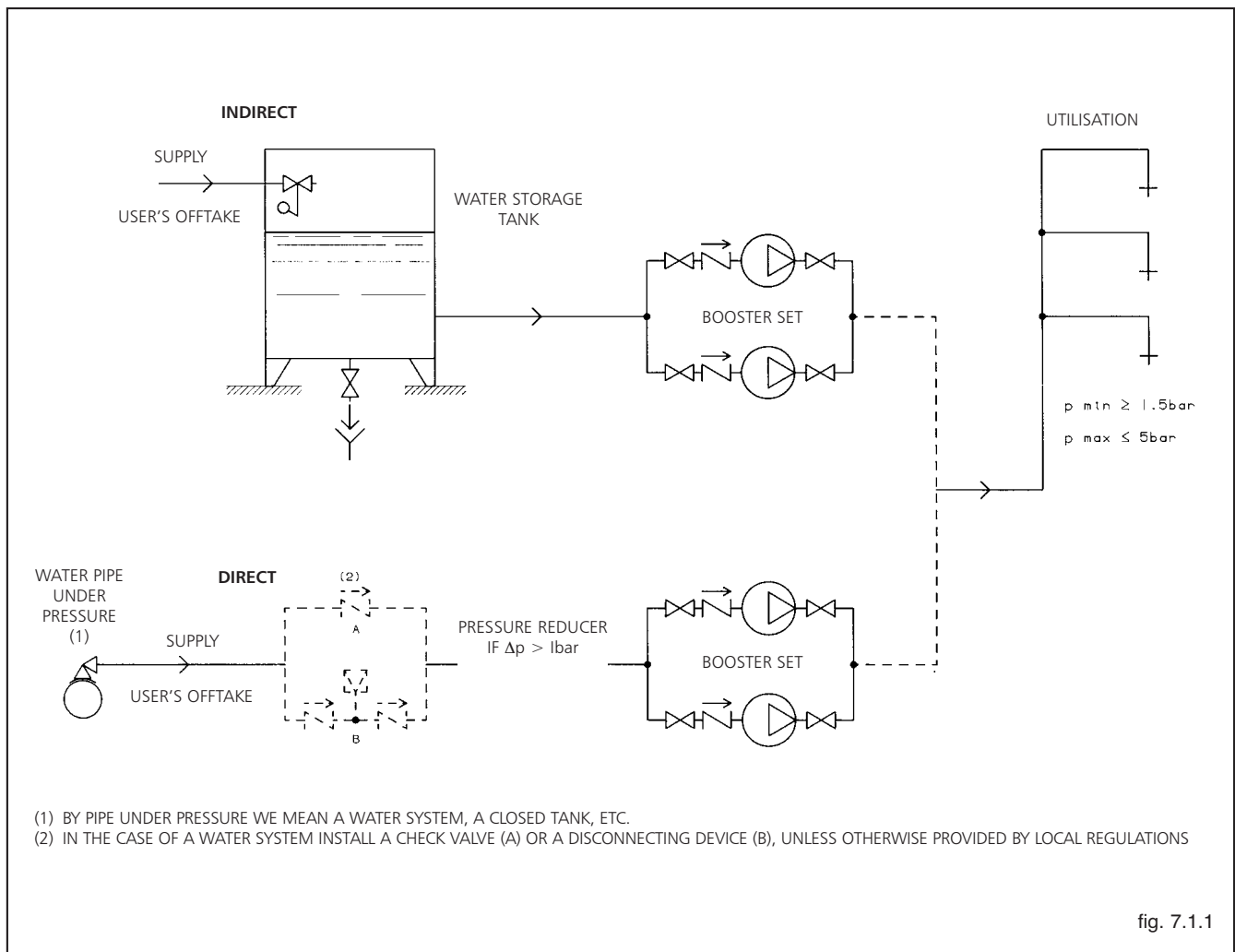

Water supply systems in civil buildings

The configuration of the supply system must comply with the following conditions:

- The minimum pressure ensuring the proper operation of the equipment must be guaranteed at the most unfavourable drawing point (1.5 bar for valves and flush tank WC, and 2 bar for controlled flushing system WC).
- At the most favourable drawing point, pressure must not exceed 5 bar.

Once these parameters have been satisfied, in relation to the height of the building and to the set intake conditions, the water supply system can have one of the following configurations:

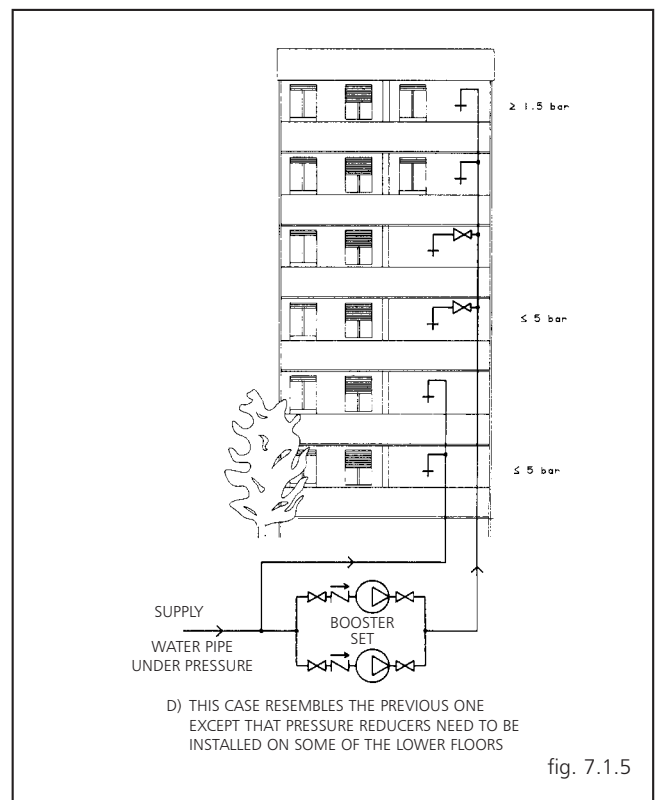
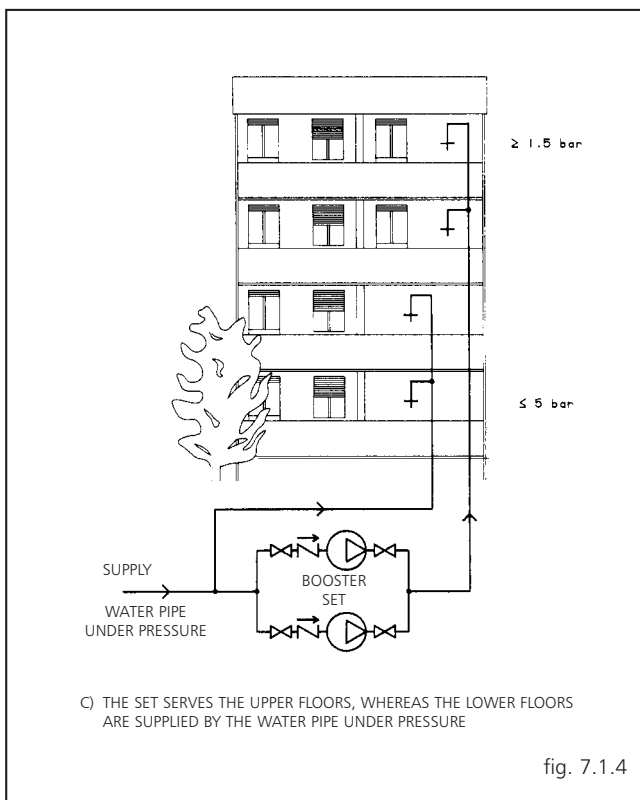
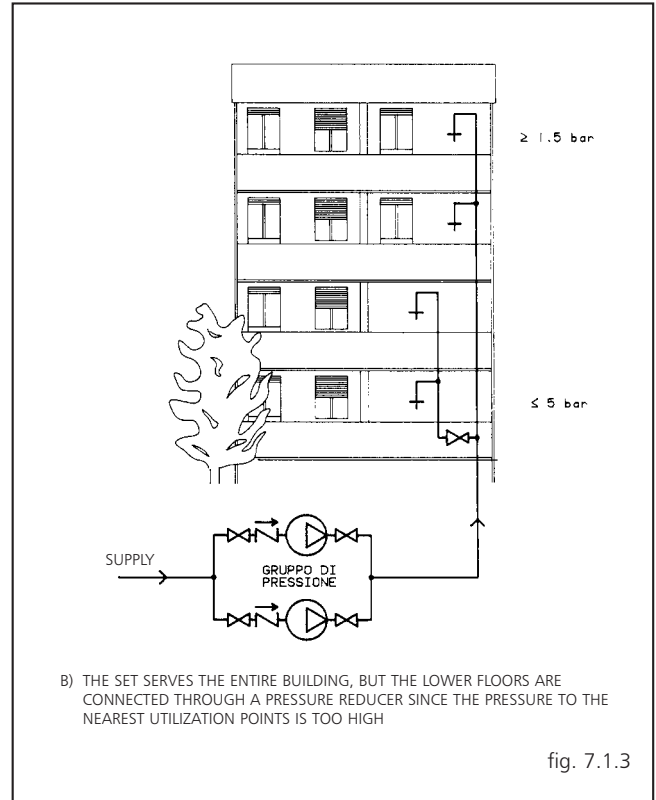
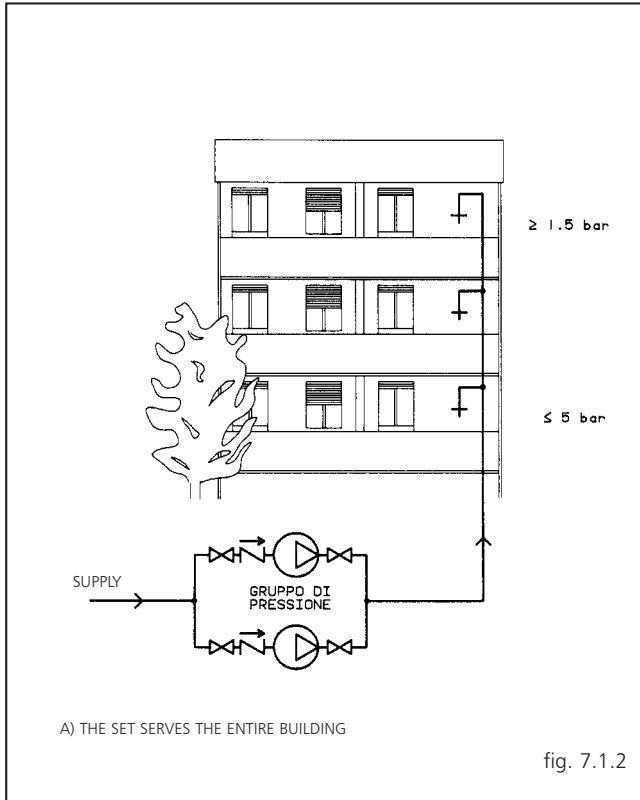

DETERMINING THE HEAD OF THE SET AND INTAKE CONDITIONS

Level intake

The delivery head of the set (H_{tot}) is the sum of:

- H_e : geodetic difference in level between the set and the furthest delivery point.
- H_c : flow resistance along all the pipes and through other system components, such as valves, filters, etc..
- H_r : pressure required at the most unfavourable point.

$$H_{tot} = H_e + H_c + H_r$$

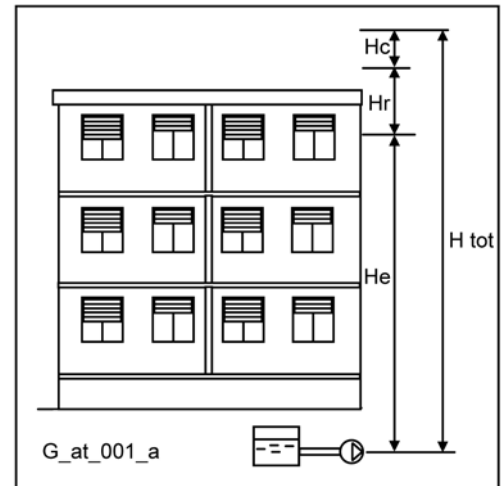

Intake with positive head

In this case, the necessary delivery head (H_{tot}) will be reduced by the inlet pressure value (H_i).

$$H_{tot} = H_e + H_c + H_r - H_i$$

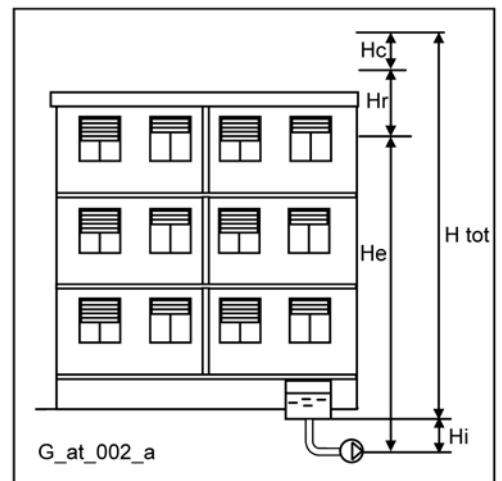

Intake with negative head

When the pumps suck from an underground tank or well, the necessary head will be increased by the value of the intake height (H_a):.

$$H_{tot} = H_e + H_c + H_r + H_a$$

In this case the intake height must be considered very carefully, bearing in mind that an excessive difference in level between the water storage tank and the set, or the wrong sizing of the intake pipe, can have adverse effects on pump operation, such as cavitation and unpriming.

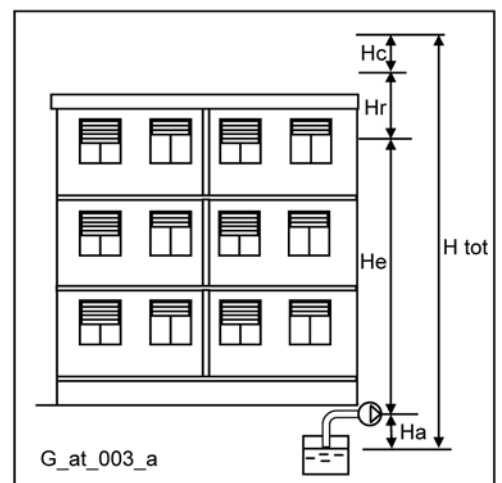

PERFORMANCE WITH VARYING SPEED EQUIVALENCE RELATIONS

Fitting the electric pump with a frequency converter makes it possible to vary the pump rotation speed, normally according to the system pressure parameter. **Variations in electric pump speed result in modified performances** according to the equivalence relations.

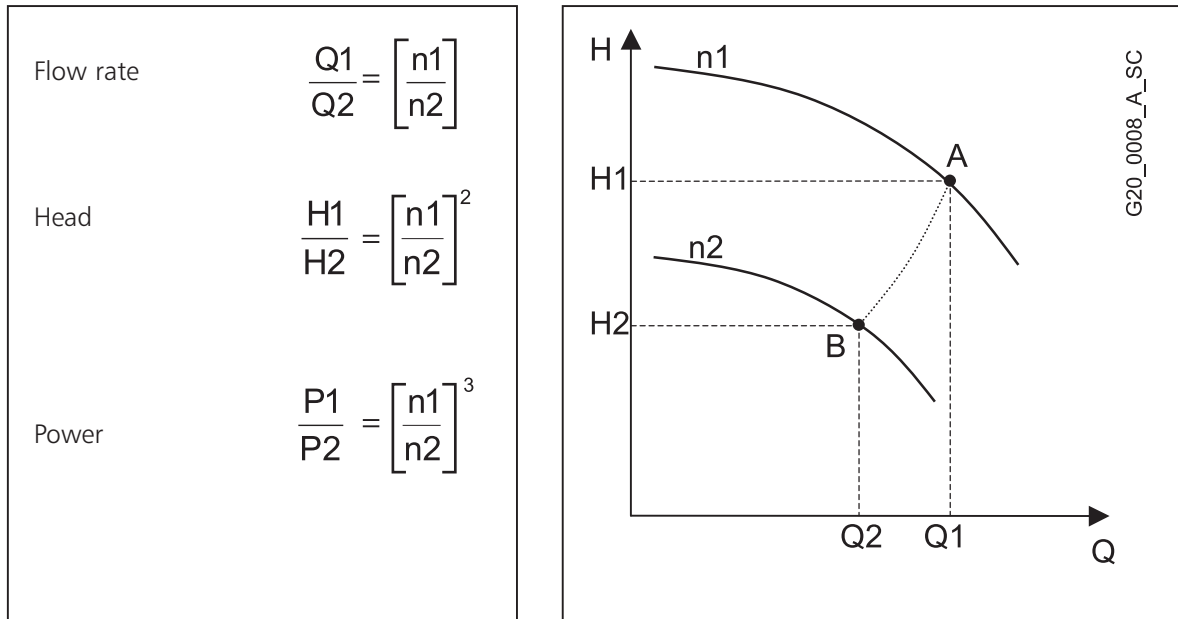

n1 = initial speed;	n2= speed required.
Q1 = initial flow rate;	Q2= flow rate required.
H1 = initial head;	H2= head required.
P1 = initial power;	P2= power required

Frequency ratios can be used instead of speed in practical applications, keeping 30 Hz as the bottom limit.

Example : 2-pole 50 Hz electric pump n1 =2900 (point A)
 Flow rate (A) = 100 l/min; Head (A) = 50m
 By reducing the frequency to 30 Hz the speed is reduced to approx. n2 = 1740 rpm (point B)
 Flow rate (B) = 60 l/min; Head (B) = 18 m
 The power of the new work point B is cut to about 22% of the initial power.

SIZING THE DIAPHRAGM TANK IN SYSTEMS WITH SPEED VARIATION

Variable speed booster sets need **smaller tanks** compared to traditional systems. Generally speaking, a tank with a litre capacity of just 10% of the nominal capacity of a single pump, expressed in litres per minute, is needed. The **gradual starting** of the pumps controlled by the frequency converters reduces the need to limit the number of hourly starts; the main purpose of the tank is to compensate for small system losses, stabilize the pressure and make up for pressure variations caused by sudden demand.

Make the following calculation:
 Set made up of three electric pumps, each with a maximum flow rate of 400 l/min, for a total capacity of 1200 l/min. The **volume** required for the tank is 40 litres. This size can be obtained by using two 24-litre tanks mounted directly onto the set's manifold.
 The calculation establishes the minimum value needed for proper operation.

NPSH

The minimum operating values that can be reached at the pump suction end are limited by the onset of cavitation.

Cavitation is the formation of vapour-filled cavities within liquids where the pressure is locally reduced to a critical value, or where the local pressure is equal to, or just below the vapour pressure of the liquid.

The vapour-filled cavities flow with the current and when they reach a higher pressure area the vapour contained in the cavities condenses. The cavities collide, generating pressure waves that are transmitted to the walls. These, being subjected to stress cycles, gradually become deformed and yield due to fatigue. This phenomenon, characterized by a metallic noise produced by the hammering on the pipe walls, is called incipient cavitation.

The damage caused by cavitation may be magnified by electrochemical corrosion and a local rise in temperature due to the plastic deformation of the walls. The materials that offer the highest resistance to heat and corrosion are alloy steels, especially austenitic steel. The conditions that trigger cavitation may be assessed by calculating the total net suction head, referred to in technical literature with the acronym NPSH (Net Positive Suction Head).

The NPSH represents the total energy (expressed in m.) of the liquid measured at suction under conditions of incipient cavitation, excluding the vapour pressure (expressed in m.) that the liquid has at the pump inlet.

To find the static height h_z at which to install the machine under safe conditions, the following formula must be verified:

$$h_p + h_z \geq (\text{NPSH}_r + 0.5) + h_f + h_{pv} \quad \textcircled{1}$$

where:

- h_p** is the absolute pressure applied to the free liquid surface in the suction tank, expressed in m. of liquid; h_p is the quotient between the barometric pressure and the specific weight of the liquid.
- h_z** is the suction lift between the pump axis and the free liquid surface in the suction tank, expressed in m.; h_z is negative when the liquid level is lower than the pump axis.
- h_f** is the flow resistance in the suction line and its accessories, such as: fittings, foot valve, gate valve, elbows, etc.
- h_{pv}** is the vapour pressure of the liquid at the operating temperature, expressed in m. of liquid. h_{pv} is the quotient between the Pv vapour pressure and the liquid's specific weight.
- 0,5** is the safety factor.

The maximum possible suction head for installation depends on the value of the atmospheric pressure (i.e. the elevation above sea level at which the pump is installed) and the temperature of the liquid.

To help the user, with reference to water temperature (4° C) and to the elevation above sea level, the following tables show the drop in hydraulic pressure head in relation to the elevation above sea level, and the suction loss in relation to temperature.

Water temperature (°C)	20	40	60	80	90	110	120
Suction loss (m)	0,2	0,7	2,0	5,0	7,4	15,4	21,5

Elevation above sea level (m)	500	1000	1500	2000	2500	3000
Suction loss (m)	0,55	1,1	1,65	2,2	2,75	3,3

Friction loss is shown in the tables at pages 136-137 of this catalogue. To reduce it to a minimum, especially in cases of high suction head (over 4-5 m.) or within the operating limits with high flow rates, we recommend using a suction line having a larger diameter than that of the pump's suction port. It is always a good idea to position the pump as close as possible to the liquid to be pumped.

Make the following calculation:

Liquid: water at ~15°C $\gamma = 1 \text{ kg/dm}^3$

Flow rate required: 30 m³/h

Head for required delivery: 43 m.

Suction lift: 3,5 m.

The selection is an FHE 40-200/75 pump whose NPSH required value is, at 30 m³/h, di 2,5 m.

For water at 15 °C

$$h_p = P_a / \gamma = 10,33\text{m}, h_{pv} = P_v / \gamma = 0,174\text{m} (0,01701 \text{ bar})$$

The H_f flow resistance in the suction line with foot valves is ~ 1,2 m.

By substituting the parameters in formula $\textcircled{1}$ with the numeric values above, we have:

$$10,33 + (-3,5) \geq (2,5 + 0,5) + 1,2 + 0,17$$

from which we have: 6,8 > 4,4

The relation is therefore verified.

TECHNICAL APPENDIX VAPOUR PRESSURE PS VAPOUR PRESSURE AND ρ DENSITY OF WATER TABLE

t °C	T K	ps bar	ρ kg/dm ³	t °C	T K	ps bar	ρ kg/dm ³	t °C	T K	ps bar	ρ kg/dm ³
0	273,15	0,00611	0,9998	55	328,15	0,15741	0,9857	120	393,15	1,9854	0,9429
1	274,15	0,00657	0,9999	56	329,15	0,16511	0,9852	122	395,15	2,1145	0,9412
2	275,15	0,00706	0,9999	57	330,15	0,17313	0,9846	124	397,15	2,2504	0,9396
3	276,15	0,00758	0,9999	58	331,15	0,18147	0,9842	126	399,15	2,3933	0,9379
4	277,15	0,00813	1,0000	59	332,15	0,19016	0,9837	128	401,15	2,5435	0,9362
5	278,15	0,00872	1,0000	60	333,15	0,1992	0,9832	130	403,15	2,7013	0,9346
6	279,15	0,00935	1,0000	61	334,15	0,2086	0,9826	132	405,15	2,867	0,9328
7	280,15	0,01001	0,9999	62	335,15	0,2184	0,9821	134	407,15	3,041	0,9311
8	281,15	0,01072	0,9999	63	336,15	0,2286	0,9816	136	409,15	3,223	0,9294
9	282,15	0,01147	0,9998	64	337,15	0,2391	0,9811	138	411,15	3,414	0,9276
10	283,15	0,01227	0,9997	65	338,15	0,2501	0,9805	140	413,15	3,614	0,9258
11	284,15	0,01312	0,9997	66	339,15	0,2615	0,9799	145	418,15	4,155	0,9214
12	285,15	0,01401	0,9996	67	340,15	0,2733	0,9793	155	428,15	5,433	0,9121
13	286,15	0,01497	0,9994	68	341,15	0,2856	0,9788	160	433,15	6,181	0,9073
14	287,15	0,01597	0,9993	69	342,15	0,2984	0,9782	165	438,15	7,008	0,9024
15	288,15	0,01704	0,9992	70	343,15	0,3116	0,9777	170	443,15	7,920	0,8973
16	289,15	0,01817	0,9990	71	344,15	0,3253	0,9770	175	448,15	8,924	0,8921
17	290,15	0,01936	0,9988	72	345,15	0,3396	0,9765	180	453,15	10,027	0,8869
18	291,15	0,02062	0,9987	73	346,15	0,3543	0,9760	185	458,15	11,233	0,8815
19	292,15	0,02196	0,9985	74	347,15	0,3696	0,9753	190	463,15	12,551	0,8760
20	293,15	0,02337	0,9983	75	348,15	0,3855	0,9748	195	468,15	13,987	0,8704
21	294,15	0,24850	0,9981	76	349,15	0,4019	0,9741	200	473,15	15,550	0,8647
22	295,15	0,02642	0,9978	77	350,15	0,4189	0,9735	205	478,15	17,243	0,8588
23	296,15	0,02808	0,9976	78	351,15	0,4365	0,9729	210	483,15	19,077	0,8528
24	297,15	0,02982	0,9974	79	352,15	0,4547	0,9723	215	488,15	21,060	0,8467
25	298,15	0,03166	0,9971	80	353,15	0,4736	0,9716	220	493,15	23,198	0,8403
26	299,15	0,03360	0,9968	81	354,15	0,4931	0,9710	225	498,15	25,501	0,8339
27	300,15	0,03564	0,9966	82	355,15	0,5133	0,9704	230	503,15	27,976	0,8273
28	301,15	0,03778	0,9963	83	356,15	0,5342	0,9697	235	508,15	30,632	0,8205
29	302,15	0,04004	0,9960	84	357,15	0,5557	0,9691	240	513,15	33,478	0,8136
30	303,15	0,04241	0,9957	85	358,15	0,5780	0,9684	245	518,15	36,523	0,8065
31	304,15	0,04491	0,9954	86	359,15	0,6011	0,9678	250	523,15	39,776	0,7992
32	305,15	0,04753	0,9951	87	360,15	0,6249	0,9671	255	528,15	43,246	0,7916
33	306,15	0,05029	0,9947	88	361,15	0,6495	0,9665	260	533,15	46,943	0,7839
34	307,15	0,05318	0,9944	89	362,15	0,6749	0,9658	265	538,15	50,877	0,7759
35	308,15	0,05622	0,9940	90	363,15	0,7011	0,9652	270	543,15	55,058	0,7678
36	309,15	0,05940	0,9937	91	364,15	0,7281	0,9644	275	548,15	59,496	0,7593
37	310,15	0,06274	0,9933	92	365,15	0,7561	0,9638	280	553,15	64,202	0,7505
38	311,15	0,06624	0,9930	93	366,15	0,7849	0,9630	285	558,15	69,186	0,7415
39	312,15	0,06991	0,9927	94	367,15	0,8146	0,9624	290	563,15	74,461	0,7321
40	313,15	0,07375	0,9923	95	368,15	0,8453	0,9616	295	568,15	80,037	0,7223
41	314,15	0,07777	0,9919	96	369,15	0,8769	0,9610	300	573,15	85,927	0,7122
42	315,15	0,08198	0,9915	97	370,15	0,9094	0,9602	305	578,15	92,144	0,7017
43	316,15	0,09639	0,9911	98	371,15	0,9430	0,9596	310	583,15	98,70	0,6906
44	317,15	0,09100	0,9907	99	372,15	0,9776	0,9586	315	588,15	105,61	0,6791
45	318,15	0,09582	0,9902	100	373,15	1,0133	0,9581	320	593,15	112,89	0,6669
46	319,15	0,10086	0,9898	102	375,15	1,0878	0,9567	325	598,15	120,56	0,6541
47	320,15	0,10612	0,9894	104	377,15	1,1668	0,9552	330	603,15	128,63	0,6404
48	321,15	0,11162	0,9889	106	379,15	1,2504	0,9537	340	613,15	146,05	0,6102
49	322,15	0,11736	0,9884	108	381,15	1,3390	0,9522	350	623,15	165,35	0,5743
50	323,15	0,12335	0,9880	110	383,15	1,4327	0,9507	360	633,15	186,75	0,5275
51	324,15	0,12961	0,9876	112	385,15	1,5316	0,9491	370	643,15	210,54	0,4518
52	325,15	0,13613	0,9871	114	387,15	1,6362	0,9476	374,15	647,30	221,20	0,3154
53	326,15	0,14293	0,9862	116	389,15	1,7465	0,9460				
54	327,15	0,15002	0,9862	118	391,15	1,8628	0,9445				

G-at_nps_h_a_sc

CHOOSING AND SIZING THE SURGE TANK

The purpose of the surge tank is to limit the number of hourly starts of the pumps, placing part of its stock of water, which is maintained under pressure by the air above it, at the disposal of the system.

The surge tank can be of the air cushion or diaphragm type.

In the air cushion version there is no clear separation between air and water. Since part of the air tends to mix with water, it is necessary to restore it by means of air supply units or a compressor.

In the diaphragm version, neither air supply units nor compressor are needed, as contact between air and water is prevented by a flexible diaphragm inside the tank.

The following method, which is used to determine the volume of a surge tank, is valid both for horizontal and vertical surge tanks.

When calculating the volume of the surge tank, it is generally sufficient to consider the first pump only.

AIR-CUSHION SURGE TANK

It is determined in relation to flow rate, pump pressure, and number of starts per hour allowed by the motor.

$$V_a = \frac{1,25 \times Q_p \times (P_{max} + 10)}{4 \times Z \times (P_{max} - P_{min})}$$

where:

- V_a = Total volume of the air-cushion surge tank in m^3
- Q_p = Average pump flow rate in m^3/h
- P_{max} = Maximum pressure setting (wcm)
- P_{min} = Minimum pressure setting (wcm)
- Z = Maximum number of starts per hour allowed by the motor

Warning! By pump flow rate we mean the average between the flow rate at the maximum pressure switch setting (Q_{max}) and the flow rate at the minimum pressure switch setting (Q_{min}), i.e.:

$$Q_p = \frac{Q_{max} + Q_{min}}{2} \quad (m^3/h)$$

Example:

- CN 32 - 160/22 pump
- P_{max} = 32 mca
- P_{min} = 22 mca
- Q_p = 18 m^3/h
- Z = 30

$$V_a = \frac{1,25 \times 18 \times (32 + 10)}{4 \times 30 \times (32 - 22)} = 0,788 \quad m^3$$

A 750-litre surge tank is therefore required.

DIAPHRAGM TANK

If you decide to use a diaphragm tank, the volume will be lower than that of the air-cushion tank. It can be calculated with the following formula:

$$V_m = \frac{Q_p}{4 \times Z} \times \frac{1}{1 - \frac{(P_{min} - 2)}{P_{max}}}$$

where:

- V_m = Total volume of the air-cushion surge tank in m^3
- Q_p = Average pump flow rate in m^3/h
- P_{max} = Maximum pressure setting (wcm)
- P_{min} = Minimum pressure setting (wcm)
- Z = Maximum number of starts per hour allowed by the motor

Example:

- CN 32 - 160/22 pump
- P_{max} = 32 mca
- P_{min} = 22 mca
- Q_p = 18 m^3/h
- Z = 30

$$V_m = \frac{Q_p}{4 \times Z} \times \frac{1}{1 - \frac{(P_{min} - 2)}{P_{max}}} = 0,4 \quad m^3$$

A 500-litre surge tank is therefore required.

Approximate comparison between Lowara air-cushion tanks and diaphragm tanks, as regards some pressure switch setting values

NOMINAL CAPACITY OF AIR CUSHION TANK (litres)	PRESSURE SWITCH SETTING (bar) min/max									
	1,5/2,5	2/3	2,5/3,5	3/4	3,5/4,5	4/5	4,5/5,5	5/6	5,5/6,5	6/7
	NOMINAL CAPACITY OF DIAPHRAGM VESSEL (litres)									
100	N ² ball type vessels/cylinder type vessels or 60l Export tank or 100-litre vessels (ISPESL tested)									
200	100									
300	200									
500	300									
1000	500									
1500	500 + 200		500 + 300							
2000	500 + 500									
2500	500 + 500	500 + 500 + 300								500 + 500

s_swp-en_a_th

TABLE OF FLOW RESISTANCE IN 100 m OF STRAIGHT CAST IRON PIPELINE (HAZEN-WILLIAMS FORMULA C=100)

FLOW RATE		NOMINAL DIAMETER in mm and INCHES																													
m ³ /h	l/min	15	20	25	32	40	50	65	80	100	125	150	175	200	250	300	350	400													
		1/2"	3/4"	1"	1 1/4"	1 1/2"	2	2 1/2"	3"	4"	5"	6"	7"	8"	10"	12"	14"	16"													
0,6	10	v hr	0,94 16	0,53 3,94	0,34 1,33	0,21 0,40	0,13 0,13	The hr values must be multiplied by: 0.71 for galvanized or painted steel pipes 0.54 for stainless steel or copper pipes 0.47 for PVC or PE pipes																							
0,9	15	v hr	1,42 33,9	0,80 8,35	0,51 2,82	0,31 0,85	0,20 0,29																								
1,2	20	v hr	1,89 57,7	1,06 14,21	0,68 4,79	0,41 1,44	0,27 0,49													0,17 0,16											
1,5	25	v hr	2,36 87,2	1,33 21,5	0,85 7,24	0,52 2,18	0,33 0,73													0,21 0,25											
1,8	30	v hr	2,83 122	1,59 30,1	1,02 10,1	0,62 3,05	0,40 1,03													0,25 0,35											
2,1	35	v hr	3,30 162	1,86 40,0	1,19 13,5	0,73 4,06	0,46 1,37													0,30 0,46											
2,4	40	v hr		2,12 51,2	1,36 17,3	0,83 5,19	0,53 1,75													0,34 0,59	0,20 0,16										
3	50	v hr		2,65 77,4	1,70 26,1	1,04 7,85	0,66 2,65													0,42 0,89	0,25 0,25										
3,6	60	v hr		3,18 108	2,04 36,6	1,24 11,0	0,80 3,71													0,51 1,25	0,30 0,35										
4,2	70	v hr		3,72 144	2,38 48,7	1,45 14,6	0,93 4,93													0,59 1,66	0,35 0,46										
4,8	80	v hr		4,25 185	2,72 62,3	1,66 18,7	1,06 6,32													0,68 2,13	0,40 0,59										
5,4	90	v hr			3,06 77,5	1,87 23,3	1,19 7,85													0,76 2,65	0,45 0,74	0,30 0,27									
6	100	v hr			3,40 94,1	2,07 28,3	1,33 9,54													0,85 3,22	0,50 0,90	0,33 0,33									
7,5	125	v hr			4,25 142	2,59 42,8	1,66 14,4													1,06 4,86	0,63 1,36	0,41 0,49									
9	150	v hr				3,11 59,9	1,99 20,2													1,27 6,82	0,75 1,90	0,50 0,69	0,32 0,23								
10,5	175	v hr				3,63 79,7	2,32 26,9													1,49 9,07	0,88 2,53	0,58 0,92	0,37 0,31								
12	200	v hr				4,15 102	2,65 34,4													1,70 11,6	1,01 3,23	0,66 1,18	0,42 0,40								
15	250	v hr				5,18 154	3,32 52,0													2,12 17,5	1,26 4,89	0,83 1,78	0,53 0,60	0,34 0,20							
18	300	v hr				3,98 72,8	2,55 24,6													1,51 6,85	1,00 2,49	0,64 0,84	0,41 0,28								
24	400	v hr				5,31 124	3,40 41,8													2,01 11,66	1,33 4,24	0,85 1,43	0,54 0,48	0,38 0,20							
30	500	v hr				6,63 187	4,25 63,2	2,51 17,6	1,66 6,41	1,06 2,16	0,68 0,73	0,47 0,30																			
36	600	v hr				5,10 88,6	3,02 24,7	1,99 8,98	1,27 3,03	0,82 1,02	0,57 0,42	0,42 0,20	0,42																		
42	700	v hr				5,94 118	3,52 32,8	2,32 11,9	1,49 4,03	0,95 1,36	0,66 0,56	0,49 0,26																			
48	800	v hr				6,79 151	4,02 42,0	2,65 15,3	1,70 5,16	1,09 1,74	0,75 0,72	0,55 0,34																			
54	900	v hr				7,64 188	4,52 52,3	2,99 19,0	1,91 6,41	1,22 2,16	0,85 0,89	0,62 0,42																			
60	1000	v hr				5,03 63,5	3,32 23,1	2,12 7,79	1,36 2,63	0,94 1,08	0,69 0,51	0,53 0,27	0,53																		
75	1250	v hr				6,28 96,0	4,15 34,9	2,65 11,8	1,70 3,97	1,18 1,63	0,87 0,77	0,66 0,40																			
90	1500	v hr				7,54 134	4,98 48,9	3,18 16,5	2,04 5,57	1,42 2,29	1,04 1,08	0,80 0,56																			
105	1750	v hr				8,79 179	5,81 65,1	3,72 21,9	2,38 7,40	1,65 3,05	1,21 1,44	0,93 0,75																			
120	2000	v hr				6,63 83,3	4,25 28,1	2,72 9,48	1,89 3,90	1,39 1,84	1,06 0,96	0,68 0,32	0,68																		
150	2500	v hr				8,29 126	5,31 42,5	3,40 14,3	2,36 5,89	1,73 2,78	1,33 1,45	0,85 0,49																			
180	3000	v hr							6,37 59,5	4,08 20,1	2,83 3,90	2,08 2,03	1,59 0,69	1,02 0,69	0,71 0,28																
210	3500	v hr							7,43 79,1	4,76 26,7	3,30 11,0	2,43 5,18	1,86 2,71	1,19 0,91	0,83 0,38																
240	4000	v hr							8,49 101	5,44 34,2	3,77 14,1	2,77 6,64	2,12 3,46	1,36 1,17	0,94 0,48																
300	5000	v hr							6,79 51,6	4,72 21,2	3,47 10,0	2,65 5,23	1,70 1,77	1,18 0,73																	
360	6000	v hr							8,15 72,3	5,66 29,8	4,16 14,1	3,18 7,33	2,04 2,47	1,42 1,02																	
420	7000	v hr								6,61 39,6	4,85 18,7	3,72 9,75	2,38 3,29	1,65 1,35	1,21 0,64																
480	8000	v hr								7,55 50,7	5,55 23,9	4,25 12,49	2,72 4,21	1,89 1,73	1,39 0,82																
540	9000	v hr								8,49 63,0	6,24 29,8	4,78 15,5	3,06 5,24	2,12 2,16	1,56 1,02	1,19 0,53															
600	10000	v hr								6,93 36,2	5,31 18,9	3,40 6,36	2,36 2,62	1,73 1,45	1,33 0,49	0,85 0,49	0,68 0,32	0,71 0,28	0,83 0,38												

G-at-pct_a_th

hr = flow resistance for 100m of straight pipeline (m)
V = water speed (m/s)

FLOW RESISTANCE

TABLE OF FLOW RESISTANCE IN BENDS, VALVES AND GATES

The flow resistance is calculated using the equivalent pipeline length method according to the table below:

ACCESSORY TYPE	DN											
	25	32	40	50	65	80	100	125	150	200	250	300
	Equivalent pipeline length (m)											
45° bend	0,2	0,2	0,4	0,4	0,6	0,6	0,9	1,1	1,5	1,9	2,4	2,8
90° bend	0,4	0,6	0,9	1,1	1,3	1,5	2,1	2,6	3,0	3,9	4,7	5,8
90° smooth bend	0,4	0,4	0,4	0,6	0,9	1,1	1,3	1,7	1,9	2,8	3,4	3,9
Union tee or cross	1,1	1,3	1,7	2,1	2,6	3,2	4,3	5,3	6,4	7,5	10,7	12,8
Gate	-	-	-	0,2	0,2	0,2	0,4	0,4	0,6	0,9	1,1	1,3
Non return valve	1,1	1,5	1,9	2,4	3,0	3,4	4,7	5,9	7,4	9,6	11,8	13,9

G-a-pcv_a_th

The table is valid for the Hazen Williams coefficient $C = 100$ (cast iron pipework). For steel pipework, multiply the values by 1.41. For stainless steel, copper and coated cast iron pipework, multiply the values by 1.85.

When the **equivalent pipeline length** has been determined, the flow resistance is obtained from the table of flow resistance.

The values given are guideline values which are bound to vary slightly according to the model, especially for gate valves and non-return valves, for which it is a good idea to check the values supplied by the manufacturers.

Air supply unit

The most commonly used air supply unit model is the “depression” type, which uses the depression produced by the pump suction.

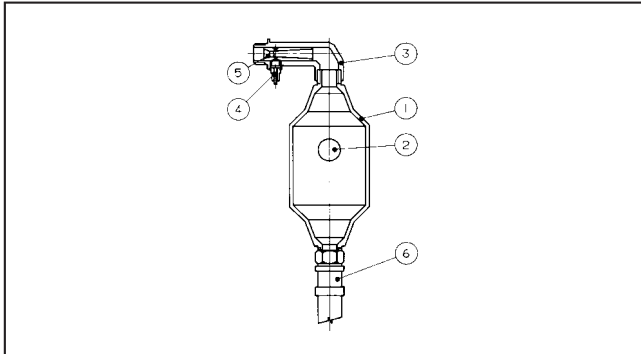

fig. 7.2.2 - The air supply unit consists of a body made of plastic material suitable for foodstuffs (1), a spherical rubber shutter (2), an upper brass union (3) with an air valve (4), a Venturi tube (5), and a flexible pipe (6) to be connected to the pump intake.

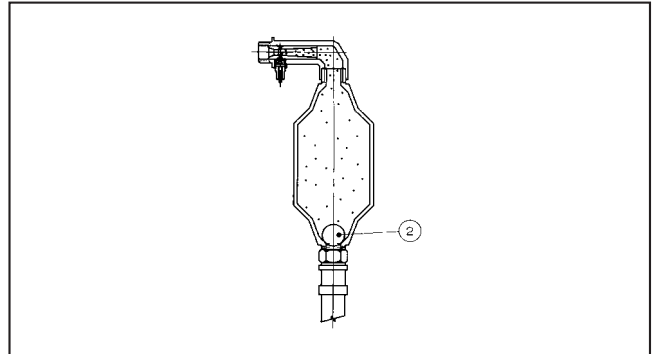

fig. 7.2.5 - The air accumulated inside the body pushes the rubber ball (2) to the bottom, thus blocking the passage. At this point the valve closes and the rubber ball prevents the air accumulated inside the body of the air supply unit from reaching the pump intake.

Air supply unit operation

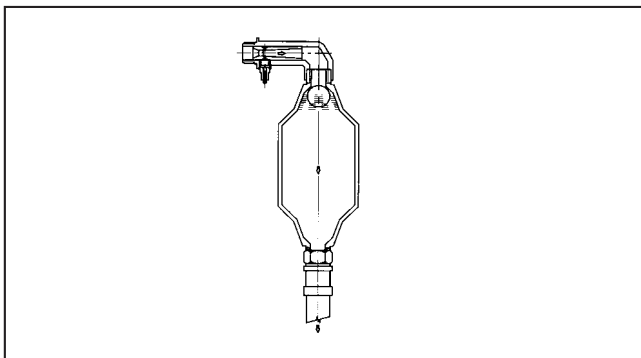

fig. 7.2.3 - When the pump starts up, the intake pressure is lower than the pressure in the surge tank. This difference causes water to flow from the surge tank to the pump intake, through the air supply unit.

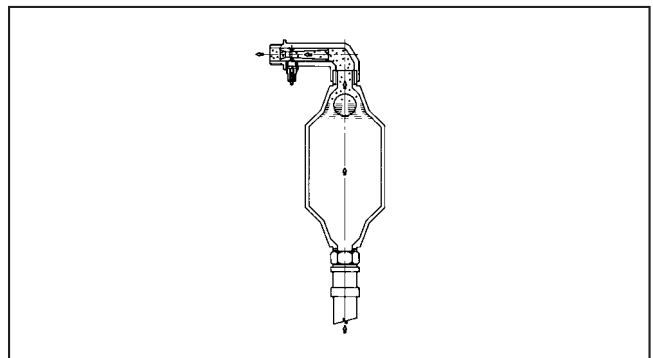

fig. 7.2.6 - When the pump stops the depression ceases and a flow of water is produced, which lifts the ball and pushes the air in the body of the supply unit into the tank.

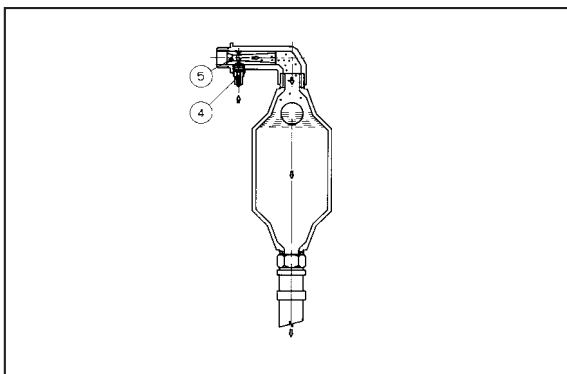

fig. 7.2.4 - The flow of water that passes through the Venturi tube (5) generates a depression and allows the opening of the air valve (4). As a consequence, air enters the body of the supply unit.

Air supply unit selection tank

TANK CAPACITY L	AVERAGE PRESSURE SETTING bar					
	2.5	3.5	4.5	5.5	6.5	7.5
100	LOW 5					
200						
300						
500						
700	LOW 10					
1000						
1500	LOW 25					
2000						
2500						
3000						
4000	LOW 40					
5000						
6000						

g_air-en_a_th

This cycle is repeated each time the pump starts up until the required quantity of air has accumulated. To ensure proper system operation, no check valve must be mounted between the pump delivery outlet and the surge tank, as it would impede the return flow of water through the pump.

ACCESSORIES/SPARE PARTS



HYDRO TUBE



PRESSURE SWITCH



FLOAT SWITCHES

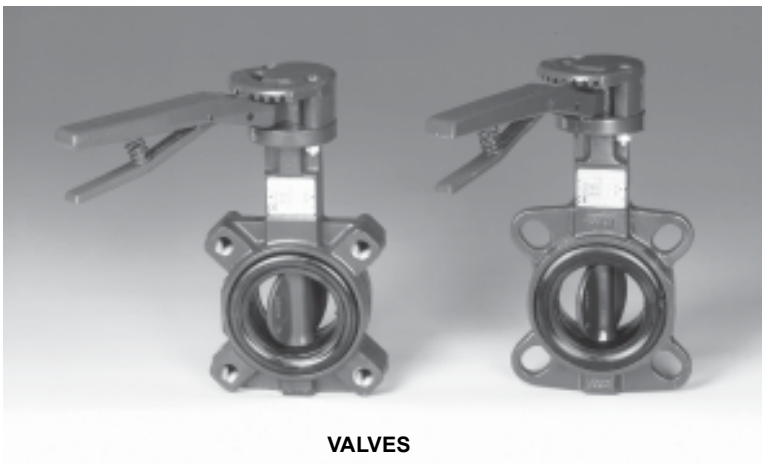

VALVES



OPTICAL SENSORS



NON-RETURN VALVES

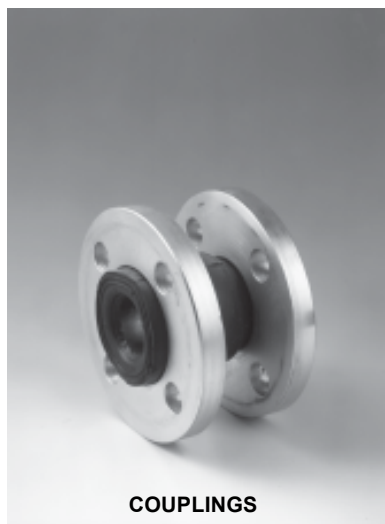

COUPLINGS



PRESSURE TRANSMITTER

VOLUMETRIC CAPACITY

Litres per minute l/min	Cubic metres per hour m ³ /h	Cubic feet per hour ft ³ /h	Cubic feet per minute ft ³ /min	Imp. gal. per minute Imp. gal./min	US gal. per minute Us gal./min
1,000	0,0600	2,1189	0,0353	0,2200	0,2642
16,6667	1,000	35,3147	0,5886	3,6662	4,4029
0,4719	0,0283	1,000	0,0167	0,1038	0,1247
28,3168	1,6990	60,0000	1,000	6,2288	7,4805
4,5461	0,2728	9,6326	0,1605	1,000	1,2009
3,7854	0,2271	8,0208	0,1337	0,8327	1,000

PRESSURE AND HEAD

Newton per square metre N/m ²	kilo Pascal kPa	bar bar	Pound force per square inch psi	metre of water m H ₂ O	millimetre of mercury mm Hg
1,000	0,0010	1 x 10 ⁻⁵	1.45 x 10 ⁻⁴	1.02 x 10 ⁻⁴	0,0075
1000,0000	1,000	0,0100	0,1450	0,1020	7,5006
1 x 10 ⁵	100,0000	1,000	14,5038	10,1972	750,0638
6894,7570	6,8948	0,0689	1,000	0,7031	51,7151
9806,6500	9,8067	0,0981	1,4223	1,000	73,5561
133,3220	0,1333	0,0013	0,0193	0,0136	1,000

LENGTH

millimetre mm	centimetre cm	metre m	inch in	foot ft	yard yd
1,000	0,1000	0,0010	0,0394	0,0033	0,0011
10,0000	1,000	0,0100	0,3937	0,0328	0,0109
1000,0000	100,0000	1,000	39,3701	3,2808	1,0936
25,4000	2,5400	0,0254	1,000	0,0833	0,0278
304,8000	30,4800	0,3048	12,0000	1,000	0,3333
914,4000	91,4400	0,9144	36,0000	3,0000	1,000

VOLUME

cubic metre m ³	litre litro	millilitre ml	imp. Gallon imp. gal.	US gallon US gal.	cubic foot ft ³
1,000	1000,0000	1 x 10 ⁶	219,9694	264,1720	35,3147
0,0010	1,000	1000,0000	0,2200	0,2642	0,0353
1 x 10 ⁻⁶	0,0010	1,000	2.2 x 10 ⁻⁴	2.642 x 10 ⁻⁴	3.53 x 10 ⁻⁵
0,0045	4,5461	4546,0870	1,000	1,2009	0,1605
0,0038	3,7854	3785,4120	0,8327	1,000	0,1337
0,0283	28,3168	28316,8466	6,2288	7,4805	1,000

G-at_pp-en_a_sc

FURTHER PRODUCT SELECTION AND DOCUMENTATION

Xylect

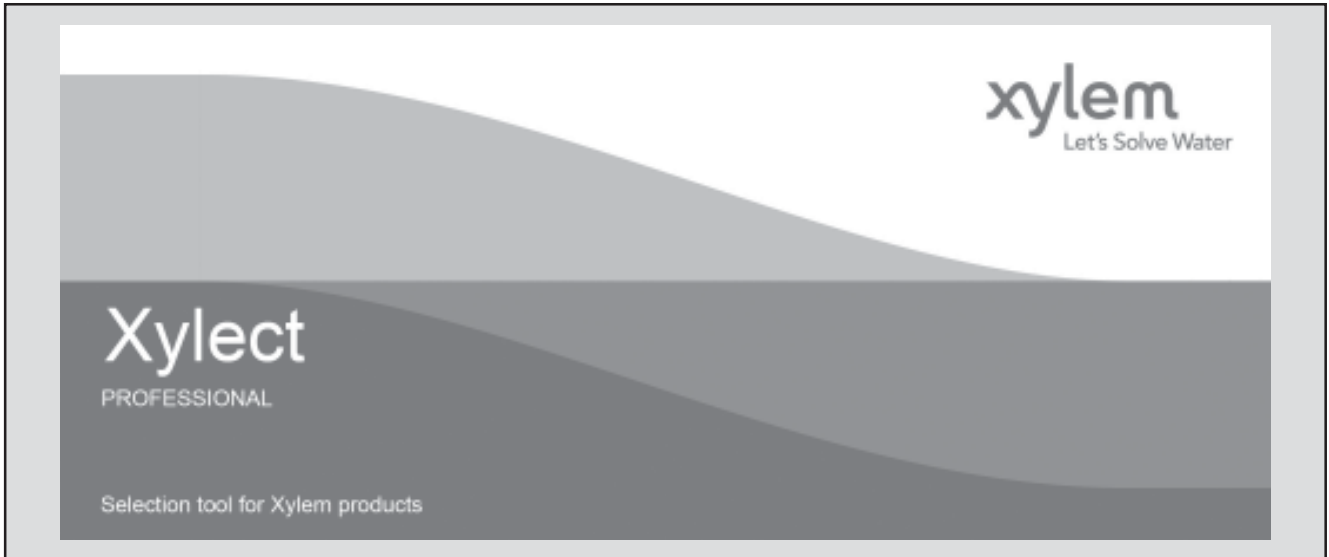

Xylect is pump solution selection software with an extensive online database of product information across the entire Lowara, and Vogel range of pumps and related products, with multiple search options and helpful project management facilities. The system holds up-to-date product information on thousands of products and accessories.

The possibility to search by applications and the detailed information output given makes it easy to make the optimal selection without having detailed knowledge about the Lowara and Vogel products.

The search can be made by:

- Application
- Product type
- Duty point

Xylect gives a detailed output:

- List with search results
- Performance curves (flow, head, power, efficiency, NPSH)
- Motor data
- Dimensional drawings
- Options
- Data sheet printouts
- Document downloads incl dxf files

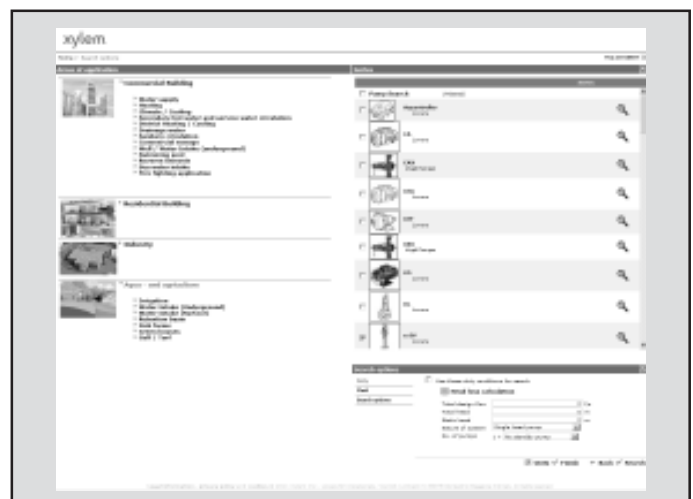

The search by application guides users not familiar with the product range to the right choice.

FURTHER PRODUCT SELECTION AND DOCUMENTATION

Xylect

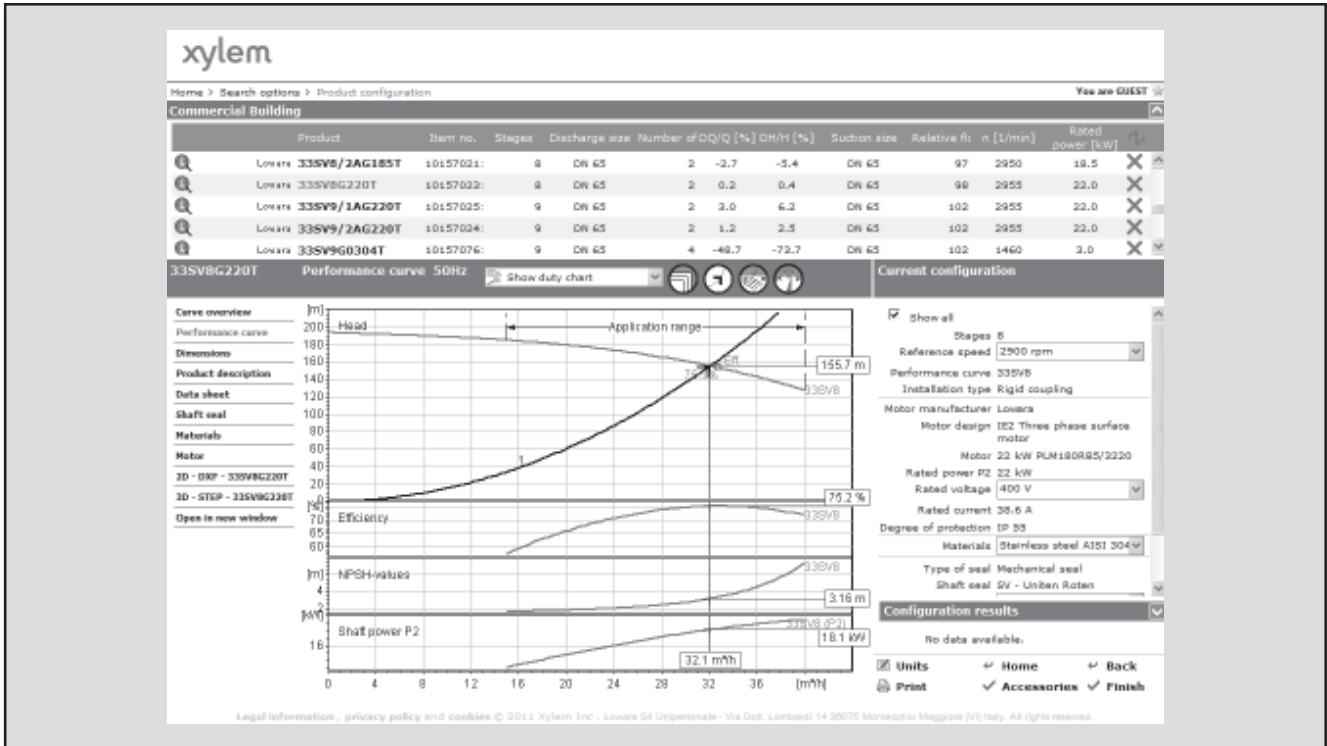

The detailed output makes it easy to select the optimal pump from the given alternatives.

The best way to work with Xylect is to create a personal account. This makes it possible to:

- Set own standard units
- Create and save projects
- Share projects with other Xylect users

Every user has a My Xylect space, where all projects are saved.

For more information about Xylect please contact our sales network or visit www.xylect.com.

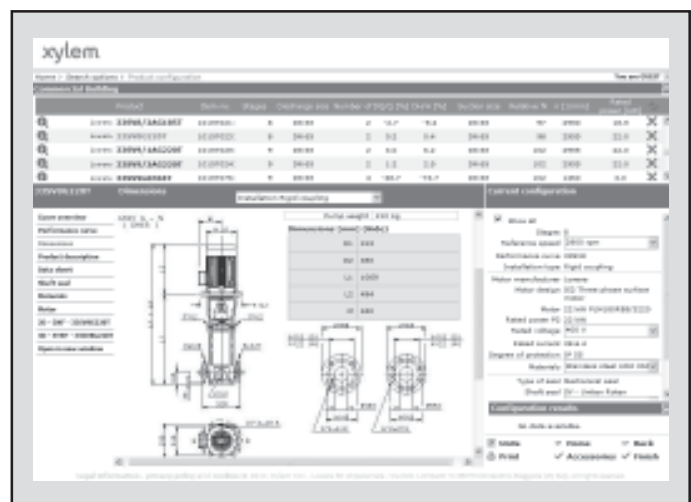

Dimensional drawings appear on the screen and can be downloaded in dxf format.

TWO-PUMP BOOSTER SETS WITH ELECTRIC PUMPS BG ELECTRICAL DATA AT 50 Hz, 2 POLES

PUMP TYPE	MOTOR TYPE	INPUT POWER*	INPUT CURRENT*		CAPACITOR	PUMP TYPE	MOTOR TYPE	INPUT POWER*	INPUT CURRENT*	
			220-240 V	380-415 V					220-240 V	380-415 V
1 ~		kW	A	A	$\mu\text{F} / 450 \text{ V}$	3 ~		kW	A	A
BGM3	SM63BG/1045	0,67	2,96		14	BG3	SM63BG/304	0,68	2,56	1,48
BGM5	SM71BG/1055	0,91	4,33		16	BG5	SM71BG/305	0,81	2,74	1,58
BGM7	SM71BG/1075	1,11	5,00		20	BG7	SM80BG/307PE	1,02	3,17	1,83
BGM9	SM71BG/1095	1,24	5,54		25	BG9	SM80BG/311PE	1,11	3,78	2,18
BGM11	SM80BG/1115	1,43	6,47		30	BG11	SM80BG/311PE	1,30	4,16	2,40

*Maximum value in specified range.

bg-2p50-en_c_te

SINGLE-PHASE MOTORS AT 50 Hz, 2 POLES

P _N kW	MOTOR TYPE	IEC SIZE	Construction Design	INPUT CURRENT		CAPACITOR		DATA FOR 230 V 50 Hz VOLTAGE					
				220-240 V	In (A)	μF	V	min ⁻¹	Is / In	η %	cos ϕ	T _N Nm	Ts/T _N
0,4	SM63BG/1045	63	SPECIAL	2,79-2,85	14	450	2745	2,64	65,1	0,96	1,39	0,68	1,63
0,55	SM71BG/1055	71		3,76-3,99	16	450	2820	3,72	68,9	0,91	1,86	0,61	2,00
0,75	SM71BG/1075	71		4,90-4,85	20	450	2765	3,42	70,1	0,96	2,59	0,58	1,75
0,95	SM71BG/1095	71		6,25-5,89	25	450	2740	3,39	71,1	0,98	3,31	0,58	1,66
1,1	SM80BG/1115	80		6,88-6,65	30	450	2800	3,89	74,7	0,96	3,75	0,46	1,72

bg-motm-2p50-en_a_te

THREE-PHASE MOTORS AT 50 Hz, 2 POLES

P _N kW	Efficiency η_N																		Year of manufacture				
	Δ 220 V						Δ 230 V			Δ 240 V			Δ 380 V			Δ 400 V				Δ 415 V			IE
	Y 380 V			Y 400 V			Y 415 V			Y 660 V			Y 690 V										
4/4	3/4	2/4	4/4	3/4	2/4	4/4	3/4	2/4	4/4	3/4	2/4	4/4	3/4	2/4	4/4	3/4	2/4	4/4	3/4	2/4			
0,4	-	-	-	-	-	-	-	-	-	-	-	-	-	-	-	-	-	-	-	-	-	By June 2011	
0,55	-	-	-	-	-	-	-	-	-	-	-	-	-	-	-	-	-	-	-	-	-		
0,75	82,5	83,1	81,3	82,8	82,7	80,1	82,6	82,0	78,9	82,5	82,0	78,9	82,5	82,0	78,9	82,5	82,0	78,9	82,5	82,0	78,9		
0,9	84,0	84,7	83,4	84,4	84,5	82,5	84,3	84,0	81,4	84,0	84,0	81,4	84,0	84,0	81,4	84,0	84,0	81,4	84,0	84,0	81,4		
1,1	84,0	84,7	83,4	84,4	84,5	82,5	84,3	84,0	81,4	84,0	84,0	81,4	84,0	84,0	81,4	84,0	84,0	81,4	84,0	84,0	81,4		

P _N kW	Manufacturer		IEC SIZE	Construction Design	N. of Poles	f _N Hz	Data for 400 V / 50 Hz Voltage				
	Lowara srl Unipersonale Reg. No. 341820260 Montecchio Maggiore Vicenza - Italia						cos ϕ	Is / I _N	T _N Nm	Ts/T _N	Tm/T _N
	Model										
0,4	SM63BG/304		63	SPECIAL	2	50	0,66	4,32	1,38	4,14	3,13
0,55	SM71BG/305		71				0,74	5,97	1,85	3,74	3,56
0,75	SM80BG/307PE		80				0,78	7,38	2,48	3,57	3,75
0,9	SM80BG/311PE		80				0,79	8,31	3,63	3,95	3,95
1,1	SM80BG/311PE		80				0,79	8,31	3,63	3,95	3,95

P _N kW	Voltage U _N											n _N min ⁻¹	See note.	Operating conditions **		
	Δ			Y			Δ			Y				Altitude Above Sea Level (m)	T. amb min/max °C	ATEX
	220 V	230 V	240 V	380 V	400 V	415 V	380 V	400 V	415 V	660 V	690 V					
0,4	2,20	2,34	2,51	1,27	1,35	1,45	-	-	-	-	-	2740 ÷ 2790	≤ 1000	-15 / 40	No	
0,55	2,56	2,56	2,62	1,48	1,48	1,51	-	-	-	-	-	2825 ÷ 2850				
0,75	2,96	2,94	2,96	1,71	1,70	1,71	1,70	1,69	1,70	0,98	0,98	2875 ÷ 2895				
0,9	4,19	4,14	4,16	2,42	2,39	2,40	2,41	2,38	2,38	1,39	1,37	2870 ÷ 2900				
1,1	4,19	4,14	4,16	2,42	2,39	2,40	2,41	2,38	2,38	1,39	1,37	2870 ÷ 2900				

Note: Observe the regulations and codes locally in force regarding sorted waste disposal.

bg-ie2-mott-2p50-en_b_te

** Operating conditions to be referred to motor only. About electric pump, refer to limits in user's manual.

TWO-PUMP BOOSTER SETS WITH ELECTRIC PUMPS HM-HMZ ELECTRICAL DATA AT 50 Hz, 2 POLES

PUMP TYPE	MOTOR TYPE	INPUT POWER*	INPUT CURRENT*	CAPACITOR	PUMP TYPE	MOTOR TYPE	INPUT POWER*	INPUT CURRENT*	INPUT CURRENT*
		kW	220-240 V A				μF / 450 V	3 ~	kW
2HM3	SM63HM/1035	0,51	2,34	10	2HM3T	SM63HM/303	0,47	1,80	1,04
2HM4	SM63HM/1045	0,66	2,92	14	2HM4T	SM63HM/304	0,67	2,56	1,48
2HM5	SM63HM/1055	0,85	3,72	16	2HM5T	SM63HM/305	0,87	2,94	1,70
2HM7	SM71HM/1075	1,13	5,09	20	2HM7T	SM80HM/307PE	1,04	3,22	1,86
4HM4	SM63HM/1045	0,62	2,77	14	4HM4T	SM63HM/304	0,62	2,51	1,45
4HM5	SM63HM/1055	0,86	3,76	16	4HM5T	SM63HM/305	0,88	2,96	1,71
4HM7	SM71HM/1095	1,29	5,74	25	4HM7T	SM80HM/311PE	1,16	3,88	2,24
4HM9	SM71HM/1095	1,45	6,49	25	4HM9T	SM80HM/311PE	1,34	4,23	2,44

*Maximum value in specified range.

hm-2p50-en_d_te

PUMP TYPE	MOTOR TYPE	INPUT POWER*	INPUT CURRENT*	CAPACITOR	PUMP TYPE	MOTOR TYPE	INPUT POWER*	INPUT CURRENT*	INPUT CURRENT*
		kW	220-240 V A				μF / 450 V	3 ~	kW
2HM3Z	SM63HM/1035	0,51	2,34	10	2HM3ZT	SM63HM/303	0,47	1,80	1,04
2HM4Z	SM63HM/1045	0,66	2,92	14	2HM4ZT	SM63HM/304	0,67	2,56	1,48
2HM5Z	SM63HM/1055	0,85	3,72	16	2HM5ZT	SM63HM/305	0,87	2,94	1,70
2HM7Z	SM71HM/1075	1,13	5,09	20	2HM7ZT	SM80HM/307PE	1,04	3,22	1,86
4HM4Z	SM63HM/1045	0,62	2,77	14	4HM4ZT	SM63HM/304	0,62	2,51	1,45
4HM5Z	SM63HM/1055	0,86	3,76	16	4HM5ZT	SM63HM/305	0,88	2,96	1,71
4HM7Z	SM71HM/1095	1,29	5,74	25	4HM7ZT	SM80HM/311PE	1,16	3,88	2,24
4HM9Z	SM71HM/1095	1,45	6,49	25	4HM9ZT	SM80HM/311PE	1,34	4,23	2,44

*Maximum value in specified range.

hmz-2p50-en_c_te

SINGLE-PHASE MOTORS AT 50 Hz, 2 POLES

P _N kW	MOTOR TYPE	IEC SIZE	Construction Design	INPUT CURRENT	CAPACITOR		DATA FOR 230 V 50 Hz VOLTAGE						
				In (A) 220-240 V	μF	V	min ⁻¹	Is / In	η %	cosφ	Tn Nm	Ts/Tn	Tm/Tn
0,3	SM63HM/1035	63	SPECIAL	2,22-2,23	10	450	2745	2,69	61,7	0,97	1,04	0,64	1,62
0,4	SM63HM/1045	63		2,79-2,85	14	450	2745	2,64	65,1	0,96	1,39	0,68	1,63
0,5	SM63HM/1055	63		3,46-3,30	16	450	2705	2,90	66,9	0,98	1,76	0,56	1,61
0,75	SM71HM/1075	71		4,90-4,85	20	450	2765	3,42	70,1	0,96	2,59	0,58	1,75
0,95	SM71HM/1095	71		6,25-5,89	25	450	2740	3,39	71,1	0,98	3,31	0,58	1,66

hm-motm-2p50-en_a_te

TWO-PUMP BOOSTER SETS WITH ELECTRIC PUMPS HM-HMZ THREE-PHASE MOTORS AT 50 Hz, 2 POLES

P _N kW	Efficiency η_N %																		Year of manufacture			
	Δ 220 V Y 380 V			Δ 230 V Y 400 V			Δ 240 V Y 415 V			Δ 380 V Y 660 V			Δ 400 V Y 690 V			Δ 415 V				IE		
	4/4	3/4	2/4	4/4	3/4	2/4	4/4	3/4	2/4	4/4	3/4	2/4	4/4	3/4	2/4	4/4	3/4	2/4				
0,3	-	-	-	-	-	-	-	-	-	-	-	-	-	-	-	-	-	-	-	-	-	By June 2011
0,4	-	-	-	-	-	-	-	-	-	-	-	-	-	-	-	-	-	-	-	-	-	
0,5	-	-	-	-	-	-	-	-	-	-	-	-	-	-	-	-	-	-	-	-	-	
0,75	82,5	83,1	81,3	82,8	82,7	80,1	82,6	82,0	78,9	82,5	82,0	78,9	82,5	82,0	78,9	82,5	82,0	78,9	3	-	-	
1,1	84,0	84,7	83,4	84,4	84,5	82,5	84,3	84,0	81,4	84,0	84,0	81,4	84,0	84,0	81,4	84,0	84,0	81,4	-	-	-	

P _N kW	Manufacturer		IEC SIZE	Construction Design	N. of Poles	f _N Hz	Data for 400 V / 50 Hz Voltage				
	Lowara srl Unipersonale Reg. No. 341820260 Montecchio Maggiore Vicenza - Italia						cos ϕ	I _s / I _N	T _N Nm	T _s /T _N	T _m /T _n
	Model										
0,3	SM63HM/303		63	SPECIAL	2	50	0,72	4,05	1,05	3,29	2,63
0,4	SM63HM/304		63				0,66	4,32	1,38	4,14	3,13
0,5	SM63HM/305		63				0,71	4,41	1,73	3,70	2,62
0,75	SM80HM/307 PE		80				0,78	7,38	2,48	3,57	3,75
1,1	SM80HM/311 PE		80				0,79	8,31	3,63	3,95	3,95

P _N kW	Voltage U _N V										n _N min ⁻¹	See note.	Operating conditions **			
	Δ			Y			Δ			Y			Altitude Above Sea Level (m)	T. amb min/max °C	ATEX	
	220 V	230 V	240 V	380 V	400 V	415 V	380 V	400 V	415 V	660 V						690 V
	I _N (A)															
0,3	1,65	1,70	1,78	0,95	0,98	1,03	-	-	-	-	-	2680 ÷ 2745	See note.	≤ 1000	-15 / 40	No
0,4	2,20	2,34	2,51	1,27	1,35	1,45	-	-	-	-	-	2740 ÷ 2790				
0,5	2,53	2,63	2,81	1,46	1,52	1,62	-	-	-	-	-	2715 ÷ 2770				
0,75	2,96	2,94	2,96	1,71	1,70	1,71	1,70	1,69	1,70	0,98	0,98	2875 ÷ 2895				
1,1	4,19	4,14	4,16	2,42	2,39	2,40	2,41	2,38	2,38	1,39	1,37	2870 ÷ 2900				

Note: Observe the regulations and codes locally in force regarding sorted waste disposal.

hm-ie2-mott-2p50-en_b_te

** Operating conditions to be referred to motor only. About electric pump, refer to limits in user's manual.

TWO-PUMP BOOSTER SETS WITH ELECTRIC PUMPS CEA ELECTRICAL DATA AT 50 Hz, 2 POLES

PUMP TYPE	MOTOR TYPE	INPUT POWER*	INPUT CURRENT*		CAPACIT.	PUMP TYPE	MOTOR TYPE	INPUT POWER*	INPUT CURRENT*	
			220-240 V	μF / 450 V					220-240 V	380-415 V
1~		kW	A			3~		kW	A	A
CEAM70/3	SM63BG/1045	0,60	2,72	14	CEA70/3	SM63BG/304	0,61	2,51	1,45	
CEAM70/5	SM71BG/1055	0,97	4,55	16	CEA70/5	SM71BG/305	0,88	2,86	1,65	
CEAM80/5	SM71BG/1075	1,07	4,87	20	CEA80/5	SM80BG/307PE	0,98	3,08	1,78	
CEAM120/3	SM71BG/1055	0,91	4,33	16	CEA120/3	SM71BG/305	0,82	2,74	1,58	
CEAM120/5	SM71BG/1095	1,39	6,24	25	CEA120/5	SM80BG/311PE	1,28	4,10	2,37	
CEAM210/2	SM71BG/1075	1,13	5,10	20	CEA210/2	SM80BG/307PE	1,04	3,22	1,86	
CEAM210/3	SM80BG/1115	1,48	6,68	30	CEA210/3	SM80BG/311PE	1,35	4,24	2,45	
CEAM210/4	SM80BG/1155	1,91	8,60	40	CEA210/4	SM80BG/315PE	1,73	5,46	3,15	
CEAM210/5	PLM90BG/1225	2,24	10,2	70	CEA210/5	PLM90BG/322	2,20	7,35	4,24	
CEAM370/1	SM80BG/1115	1,49	6,75	30	CEA370/1	SM80BG/311PE	1,40	4,35	2,51	
CEAM370/2	SM80BG/1155	2,05	9,26	40	CEA370/2	SM80BG/315PE	1,95	5,94	3,43	
CEAM370/3	PLM90BG/1225	2,45	11,1	70	CEA370/3	PLM90BG/322	2,45	7,84	4,53	
					CEA370/5	PLM90BG/330	3,26	10,1	5,86	

*Maximum value in specified range.

cea-2p50-en_f_te

SINGLE-PHASE MOTORS AT 50 Hz, 2 POLES

P _N kW	MOTOR TYPE	IEC SIZE	Construction Design	INPUT		CAPACITOR		DATA FOR 230 V 50 Hz VOLTAGE					
				CURRENT I _n (A)	220-240 V	μF	V	min ⁻¹	I _s / I _n	η %	cosφ	T _n Nm	T _s /T _n
0,4	SM63BG/1045	63	SPECIAL	2,79-2,85	14	450	2745	2,64	65,1	0,96	1,39	0,68	1,63
0,55	SM71BG/1055	71		3,76-3,99	16	450	2820	3,72	68,9	0,91	1,86	0,61	2,00
0,75	SM71BG/1075	71		4,90-4,85	20	450	2765	3,42	70,1	0,96	2,59	0,58	1,75
0,95	SM71BG/1095	71		6,25-5,89	25	450	2740	3,39	71,1	0,98	3,31	0,58	1,66
1,1	SM80BG/1115	80		6,88-6,65	30	450	2800	3,89	74,7	0,96	3,75	0,46	1,72
1,5	SM80BG/1155	80		9,21-8,58	40	450	2810	4,00	76,1	0,98	5,09	0,39	1,74
1,85	PLM80BG/1225	90		12,5-11,6	70	450	2825	4,47	82,4	0,97	7,43	0,53	1,87

cea-motm-2p50-en_a_te

TWO-PUMP BOOSTER SETS WITH ELECTRIC PUMPS CEA THREE-PHASE MOTORS AT 50 Hz, 2 POLES

P _N kW	Efficiency η_N %																		Year of manufacture				
	Δ 220 V Y 380 V			Δ 230 V Y 400 V			Δ 240 V Y 415 V			Δ 380 V Y 660 V			Δ 400 V Y 690 V			Δ 415 V				IE			
	4/4	3/4	2/4	4/4	3/4	2/4	4/4	3/4	2/4	4/4	3/4	2/4	4/4	3/4	2/4	4/4	3/4	2/4					
0,4	-	-	-	-	-	-	-	-	-	-	-	-	-	-	-	-	-	-	-	-	-	-	By June 2011
0,55	-	-	-	-	-	-	-	-	-	-	-	-	-	-	-	-	-	-	-	-	-	-	
0,75	82,5	83,1	81,3	82,8	82,7	80,1	82,6	82,0	78,9	82,5	82,0	78,9	82,5	82,0	78,9	82,5	82,0	78,9	-	-	-	-	
0,9	84,0	84,7	83,4	84,4	84,5	82,5	84,3	84,0	81,4	84,0	84,0	81,4	84,0	84,0	81,4	84,0	84,0	81,4	-	-	-	-	
1,1	84,0	84,7	83,4	84,4	84,5	82,5	84,3	84,0	81,4	84,0	84,0	81,4	84,0	84,0	81,4	84,0	84,0	81,4	-	-	-	-	
1,5	85,6	86,5	85,8	85,9	86,4	84,9	86,0	86,0	84,0	85,6	86,0	84,0	85,6	86,0	84,0	85,6	86,0	84,0	-	-	-	-	
1,85	83,7	83,7	83,7	83,7	83,7	83,7	83,7	83,7	83,7	83,7	83,7	83,7	83,7	83,7	83,7	83,7	83,7	83,7	-	-	-	-	
2,2	83,7	83,7	83,7	83,7	83,7	83,7	83,7	83,7	83,7	83,7	83,7	83,7	83,7	83,7	83,7	83,7	83,7	83,7	-	-	-	-	
3	85,5	86,8	85,6	86,1	86,8	85,6	86,3	86,8	85,6	85,5	86,8	85,6	85,5	86,8	85,6	85,5	86,8	85,6	-	-	-	-	

P _N kW	Manufacturer		IEC SIZE	Construction Design	N. of Poles	f _N Hz	Data for 400 V / 50 Hz Voltage				
	Lowara srl Unipersonale Reg. No. 341820260 Montecchio Maggiore Vicenza - Italia						cos ϕ	I _s / I _N	T _N Nm	T _s /T _N	T _m /T _N
	Model										
0,4	SM63BG/304		63	SPECIAL	2	50	0,66	4,32	1,38	4,14	3,13
0,55	SM71BG/305		71				0,74	5,97	1,85	3,74	3,56
0,75	SM80BG/307PE		80				0,78	7,38	2,48	3,57	3,75
0,9	SM80BG/311PE		80				0,79	8,31	3,63	3,95	3,95
1,1	SM80BG/311PE		80				0,79	8,31	3,63	3,95	3,95
1,5	SM80BG/315PE		80				0,80	8,80	4,96	4,31	4,10
1,85	PLM90BG/322		90				0,80	8,63	7,25	3,74	3,71
2,2	PLM90BG/322		90				0,80	8,63	7,25	3,74	3,71
3	PLM90BG/330		90				0,82	8,39	9,96	3,50	3,32

P _N kW	Voltage U _N V											n _N min ⁻¹	Operating conditions **		
	Δ			Y			Δ			Y			Altitude Above Sea Level (m)	T. amb min/max °C	ATEX
	220 V	230 V	240 V	380 V	400 V	415 V	380 V	400 V	415 V	660 V	690 V				
	I _N (A)														
0,4	2,20	2,34	2,51	1,27	1,35	1,45	-	-	-	-	-	2740 ÷ 2790	See note: ≤ 1000	-15 / 40	No
0,55	2,56	2,56	2,62	1,48	1,48	1,51	-	-	-	-	-	2825 ÷ 2850			
0,75	2,96	2,94	2,96	1,71	1,70	1,71	1,70	1,69	1,70	0,98	0,98	2875 ÷ 2895			
0,9	4,19	4,14	4,16	2,42	2,39	2,40	2,41	2,38	2,38	1,39	1,37	2870 ÷ 2900			
1,1	4,19	4,14	4,16	2,42	2,39	2,40	2,41	2,38	2,38	1,39	1,37	2870 ÷ 2900			
1,5	5,56	5,49	5,51	3,21	3,17	3,18	3,21	3,18	3,19	1,85	1,84	2870 ÷ 2895			
1,85	8,05	8,04	8,09	4,65	4,64	4,67	4,62	4,61	4,63	2,67	2,66	2885 ÷ 2900			
2,2	8,05	8,04	8,09	4,65	4,64	4,67	4,62	4,61	4,63	2,67	2,66	2885 ÷ 2900			
3	10,8	10,6	10,6	6,23	6,14	6,12	6,18	6,10	6,06	3,57	3,52	2850 ÷ 2885			

Note: Observe the regulations and codes locally in force regarding sorted waste disposal.

cea-ie2-mott-2p50-en_b_te

** Operating conditions to be referred to motor only. About electric pump, refer to limits in user's manual.

TWO-PUMP BOOSTER SETS WITH ELECTRIC PUMPS CA ELECTRICAL DATA AT 50 Hz, 2 POLES

PUMP TYPE	MOTOR TYPE	INPUT POWER*	INPUT		CAPACIT.	PUMP TYPE	MOTOR TYPE	INPUT POWER*	INPUT	
			CURRENT*	CURRENT*					CURRENT*	CURRENT*
1~		kW	220-240 V	A	$\mu\text{F} / 450 \text{ V}$	3~		kW	220-240 V	380-415 V
CAM70/33	SM71CA/1075	1,15	5,16	20		CA70/33	SM80CA/307PE	1,06	3,24	1,87
CAM70/34	SM71CA/1095	1,39	6,22	25		CA70/34	SM80CA/311PE	1,28	4,10	2,37
CAM70/45	SM80CA/1115	1,76	7,92	30		CA70/45	SM80CA/311PE	1,63	4,90	2,83
CAM120/33	SM80CA/1115	1,67	7,53	30		CA120/33	SM80CA/311PE	1,54	4,69	2,71
CAM120/35	SM80CA/1155	2,18	9,87	40		CA120/35	SM80CA/315PE	2,01	6,11	3,53
CAM120/55	PLM90CA/1225	2,54	11,5	70		CA120/55	PLM90CA/322	2,55	8,05	4,65
CAM200/33	PLM90CA/1225	2,29	10,4	70		CA200/33	PLM90CA/322	2,26	7,47	4,31
CAM200/35	PLM90CA/1225	2,94	12,6	70		CA200/35	PLM90CA/322	3,02	9,08	5,24
-	-	-	-	-	-	CA200/55	PLM90CA/330	3,51	10,7	6,18

*Maximum value in specified range.

ca-2p50-en_f_te

SINGLE-PHASE MOTORS AT 50 Hz, 2 POLES

P _N kW	MOTOR TYPE	IEC SIZE	Construction Design	INPUT			CAPACITOR		DATA FOR 230 V 50 Hz VOLTAGE					
				CURRENT I _n (A)	220-240 V	μF	V	min ⁻¹	I _s / I _n	η %	cos ϕ	T _n Nm	T _s /T _n	T _m /T _n
0,75	SM71CA/1075	71	SPECIAL	4,90-4,85	20	450	2765	3,42	70,1	0,96	2,59	0,58	1,75	
0,95	SM71CA/1095	71		6,25-5,89	25	450	2740	3,39	71,1	0,98	3,31	0,58	1,66	
1,1	SM80CA/1115	80		6,88-6,65	30	450	2800	3,89	74,7	0,96	3,75	0,46	1,72	
1,5	SM80CA/1155	80		9,21-8,58	40	450	2810	4,00	76,1	0,98	5,09	0,39	1,74	
1,85	PLM80CA/1225	90		12,5-11,6	70	450	2825	4,47	82,4	0,97	7,43	0,53	1,87	
2,2	PLM80CA/1225	90		12,5-11,6	70	450	2825	4,47	82,4	0,97	7,43	0,53	1,87	

ca-motm-2p50-en_a_te

TWO-PUMP BOOSTER SETS WITH ELECTRIC PUMPS CA THREE-PHASE MOTORS AT 50 Hz, 2 POLES

P _N kW	Efficiency η_N %																		IE	Year of manufacture
	Δ 220 V Y 380 V			Δ 230 V Y 400 V			Δ 240 V Y 415 V			Δ 380 V Y 660 V			Δ 400 V Y 690 V			Δ 415 V				
	4/4	3/4	2/4	4/4	3/4	2/4	4/4	3/4	2/4	4/4	3/4	2/4	4/4	3/4	2/4	4/4	3/4	2/4		
0,75	82,5	83,1	81,3	82,8	82,7	80,1	82,6	82,0	78,9	82,5	82,0	78,9	82,5	82,0	78,9	82,5	82,0	78,9	3	By June 2011
0,9	84,0	84,7	83,4	84,4	84,5	82,5	84,3	84,0	81,4	84,0	84,0	81,4	84,0	84,0	81,4	84,0	84,0	81,4		
1,1	84,0	84,7	83,4	84,4	84,5	82,5	84,3	84,0	81,4	84,0	84,0	81,4	84,0	84,0	81,4	84,0	84,0	81,4		
1,5	85,6	86,5	85,8	85,9	86,4	84,9	86,0	86,0	84,0	85,6	86,0	84,0	85,6	86,0	84,0	85,6	86,0	84,0		
1,85	83,7	83,7	83,7	83,7	83,7	83,7	83,7	83,7	83,7	83,7	83,7	83,7	83,7	83,7	83,7	83,7	83,7	83,7		
2,2	83,7	83,7	83,7	83,7	83,7	83,7	83,7	83,7	83,7	83,7	83,7	83,7	83,7	83,7	83,7	83,7	83,7	83,7		
3	85,5	86,8	85,6	86,1	86,8	85,6	86,3	86,8	85,6	85,5	86,8	85,6	85,5	86,8	85,6	85,5	86,8	85,6		

P _N kW	Manufacturer		IEC SIZE	Construction Design	N. of Poles	f _N Hz	Data for 400 V / 50 Hz Voltage				
	Lowara srl Unipersonale Reg. No. 341820260 Montecchio Maggiore Vicenza - Italia						cos ϕ	I _s / I _N	T _N Nm	Ts/T _N	Tm/T _N
	Model										
0,75	SM80CA/307PE		80	SPECIAL	2	50	0,78	7,38	2,48	3,57	3,75
0,9	SM80CA/311PE		80				0,79	8,31	3,63	3,95	3,95
1,1	SM80CA/311PE		80				0,79	8,31	3,63	3,95	3,95
1,5	SM80CA/315PE		80				0,80	8,80	4,96	4,31	4,10
1,85	PLM90BG/322		90				0,80	8,63	7,25	3,74	3,71
2,2	PLM90BG/322		90				0,80	8,63	7,25	3,74	3,71
3	PLM90BG/330		90				0,82	8,39	9,96	3,50	3,32

P _N kW	Voltage U _N V										n _N min ⁻¹	See note:	Operating conditions **			
	Δ			Y			Δ			Y			Altitude Above Sea Level (m)	T. amb min/max °C	ATEX	
	220 V	230 V	240 V	380 V	400 V	415 V	380 V	400 V	415 V	660 V						690 V
0,75	2,96	2,94	2,96	1,71	1,70	1,71	1,70	1,69	1,70	0,98	0,98	2875 ÷ 2895	≤ 1000	-15 / 40	No	
0,9	4,19	4,14	4,16	2,42	2,39	2,40	2,41	2,38	2,38	1,39	1,37	2870 ÷ 2900				
1,1	4,19	4,14	4,16	2,42	2,39	2,40	2,41	2,38	2,38	1,39	1,37	2870 ÷ 2900				
1,5	5,56	5,49	5,51	3,21	3,17	3,18	3,21	3,18	3,19	1,85	1,84	2870 ÷ 2895				
1,85	8,05	8,04	8,09	4,65	4,64	4,67	4,62	4,61	4,63	2,67	2,66	2885 ÷ 2900				
2,2	8,05	8,04	8,09	4,65	4,64	4,67	4,62	4,61	4,63	2,67	2,66	2885 ÷ 2900				
3	10,8	10,6	10,6	6,23	6,14	6,12	6,18	6,10	6,06	3,57	3,52	2850 ÷ 2885				

Note: Observe the regulations and codes locally in force regarding sorted waste disposal.

ca-ie2-mott-2p50-en_c_te

** Operating conditions to be referred to motor only. About electric pump, refer to limits in user's manual.

TWO-PUMP BOOSTER SETS WITH ELECTRIC PUMPS e-SV™ SINGLE-PHASE MOTORS AT 50 Hz, 2-POLE

P _N kW	MOTOR TYPE	IEC SIZE*	Construction Design	INPUT	CAPACITOR		DATA FOR 230 V 50 Hz VOLTAGE						
				CURRENT I _n (A) 220-240 V	μF	V	min ⁻¹	I _s / I _n	η %	cosφ	T _n Nm	T _s /T _n	T _m /T _n
0,37	SM71RB14/104	71R	V18/B14	2,79-2,85	14	450	2745	2,64	65,1	0,96	1,39	0,68	1,63
0,55	SM71B14/105	71		3,76-3,99	16	450	2820	3,72	68,9	0,91	1,86	0,61	2,00
0,75	SM80RB14/107	80R		4,90-4,85	20	450	2765	3,42	70,1	0,96	2,59	0,58	1,75
1,1	SM80B14/111	80		6,88-6,65	30	450	2800	3,89	74,7	0,96	3,75	0,46	1,72
1,5	SM90RB14/115	90R		9,21-8,58	40	450	2810	4,00	76,1	0,98	5,09	0,39	1,74
2,2	PLM90B14/122	90		12,5-11,6	70	450	2825	4,47	82,4	0,97	7,43	0,53	1,87

* R = Reduced size of motor casing as compared to shaft extension and flange.

1-22sv-motm-2p50-en_b_te

TWO-PUMP BOOSTER SETS WITH ELECTRIC PUMPS e-SV™ THREE-PHASE MOTORS AT 50 Hz, 2 POLES (up to 22 kW)

P _N kW	Efficiency η _N %																		IE	Year of manufacture		
	Δ 220 V Y 380 V			Δ 230 V Y 400 V			Δ 240 V Y 415 V			Δ 380 V Y 660 V			Δ 400 V Y 690 V			Δ 415 V						
	4/4	3/4	2/4	4/4	3/4	2/4	4/4	3/4	2/4	4/4	3/4	2/4	4/4	3/4	2/4	4/4	3/4	2/4				
0,37	-	-	-	-	-	-	-	-	-	-	-	-	-	-	-	-	-	-	-	-	-	-
0,55	-	-	-	-	-	-	-	-	-	-	-	-	-	-	-	-	-	-	-	-	-	-
0,75	82,5	83,1	81,3	82,8	82,7	80,1	82,6	82,0	78,9	82,5	82,0	78,9	82,5	82,0	78,9	82,5	82,0	78,9	-	-	-	-
1,1	84,0	84,7	83,4	84,4	84,5	82,5	84,3	84,0	81,4	84,0	84,0	81,4	84,0	84,0	81,4	84,0	84,0	81,4	-	-	-	-
1,5	85,6	86,5	85,8	85,9	86,4	84,9	86,0	86,0	84,0	85,6	86,0	84,0	85,6	86,0	84,0	85,6	86,0	84,0	-	-	-	-
2,2	83,7	83,7	83,7	83,7	83,7	83,7	83,7	83,7	83,7	83,7	83,7	83,7	83,7	83,7	83,7	83,7	83,7	83,7	-	-	-	-
3	85,5	86,8	85,6	86,1	86,8	85,6	86,3	86,8	85,6	85,5	86,8	85,6	85,5	86,8	85,6	85,5	86,8	85,6	-	-	-	-
4	86,3	86,3	86,3	86,3	86,3	86,3	86,3	86,3	86,3	86,3	86,3	86,3	86,3	86,3	86,3	86,3	86,3	86,3	-	-	-	-
5,5	87,6	87,6	87,6	87,6	87,6	87,6	87,6	87,6	87,6	87,6	87,6	87,6	87,6	87,6	87,6	87,6	87,6	87,6	-	-	-	-
7,5	88,6	88,1	88,1	88,6	88,1	88,1	88,6	88,1	88,1	88,6	88,1	88,1	88,6	88,1	88,1	88,6	88,1	88,1	-	-	-	-
11	90,3	91,1	90,3	90,3	91,1	90,3	90,3	91,1	90,3	90,3	91,1	90,3	90,8	91,1	90,3	91,0	91,1	90,3	-	-	-	-
15	90,3	90,3	90,3	90,3	90,3	90,3	90,3	90,3	90,3	90,3	90,3	90,3	90,3	90,3	90,3	90,3	90,3	90,3	-	-	-	-
18,5	91,2	91,2	91,2	91,2	91,2	91,2	91,2	91,2	91,2	91,2	91,2	91,2	91,2	91,2	91,2	91,2	91,2	91,2	-	-	-	-
22	91,3	91,3	91,3	91,3	91,3	91,3	91,3	91,3	91,3	91,3	91,3	91,3	91,3	91,3	91,3	91,3	91,3	91,3	-	-	-	-

P _N kW	Manufacturer		IEC SIZE*	Construction Design	N. of Poles	f _N Hz	Data for 400 V / 50 Hz Voltage				
	Lowara srl Unipersonale Reg. No. 341820260 Montecchio Maggiore Vicenza - Italia						cosφ	I _s / I _N	T _N Nm	Ts/T _N	Tm/Tn
	Model										
0,37	SM71RB14/304		71R	V18/B14	2	50	0,66	4,32	1,38	4,14	3,13
0,55	SM71B14/305		71				0,74	5,97	1,85	3,74	3,56
0,75	SM80B14/307PE		80				0,78	7,38	2,48	3,57	3,75
1,1	SM80B14/311PE		80				0,79	8,31	3,63	3,95	3,95
1,5	SM90RB14/315PE		90R				0,80	8,80	4,96	4,31	4,10
2,2	PLM90B14/322		90				0,80	8,63	7,25	3,74	3,71
3	PLM100RB14/330		100R				0,82	8,39	9,96	3,50	3,32
4	PLM112RB14/340		112R				0,85	9,52	13,1	3,04	4,40
5,5	PLM132RB5/355		132R				0,87	10,3	18,1	4,43	5,80
7,5	PLM132B5/375		132				0,87	9,21	24,5	3,26	4,55
11	PLM160RB5/3110		160R				0,87	9,72	36,0	3,46	4,56
15	PLM160B5/3150		160				0,91	8,45	48,6	2,26	3,81
18,5	PLM160B5/3185		160				0,88	9,75	59,8	2,82	4,53
22	PLM180RB5/3220		180R				0,89	9,50	71,1	2,74	4,26

P _N kW	Voltage U _N V											n _N min ⁻¹	Observe the regulations and codes locally in force regarding sorted waste disposal.	Operating conditions **		
	Δ			Y			Δ			Y				Altitude Above Sea Level (m)	T. amb min/max °C	ATEX
	220 V	230 V	240 V	380 V	400 V	415 V	380 V	400 V	415 V	660 V	690 V					
0,37	2,20	2,34	2,51	1,27	1,35	1,45	-	-	-	-	-	2740 ÷ 2790	≤ 1000	-15 / 40	No	
0,55	2,56	2,56	2,62	1,48	1,48	1,51	-	-	-	-	-	2825 ÷ 2850				
0,75	2,96	2,94	2,96	1,71	1,70	1,71	1,70	1,69	1,70	0,98	0,98	2875 ÷ 2895				
1,1	4,19	4,14	4,16	2,42	2,39	2,40	2,41	2,38	2,38	1,39	1,37	2870 ÷ 2900				
1,5	5,56	5,49	5,51	3,21	3,17	3,18	3,21	3,18	3,19	1,85	1,84	2870 ÷ 2895				
2,2	8,05	8,04	8,09	4,65	4,64	4,67	4,62	4,61	4,63	2,67	2,66	2885 ÷ 2900				
3	10,8	10,6	10,6	6,23	6,14	6,12	6,18	6,10	6,06	3,57	3,52	2850 ÷ 2885				
4	13,6	13,5	13,5	7,88	7,77	7,79	7,80	7,63	7,65	4,51	4,41	2895 ÷ 2920				
5,5	18,3	18,0	17,9	10,6	10,4	10,3	10,6	10,4	10,5	6,14	6,02	2885 ÷ 2905				
7,5	25,4	24,8	24,4	14,7	14,3	14,1	14,5	14,0	13,9	8,35	8,11	2920 ÷ 2935				
11	36,0	35,1	34,7	20,8	20,3	20,0	20,8	20,3	20,1	12,0	11,7	2910 ÷ 2925				
15	47,2	45,3	44,0	27,2	26,2	25,4	27,2	26,0	25,3	15,7	15,0	2940 ÷ 2950				
18,5	58,3	56,9	55,9	33,7	32,9	32,3	34,1	33,2	32,8	19,7	19,1	2945 ÷ 2955				
22	68,3	66,2	64,3	39,4	38,2	37,1	40,0	38,6	37,8	23,1	22,3	2945 ÷ 2955				

* R = Reduced size of motor casing as compared to shaft extension and flange.

sv-ie2-mott22-2p50-en_c_tte

** Operating conditions to be referred to motor only. About electric pump, refer to limits in user's manual.

Xylem |'zīləm|

- 1) The tissue in plants that brings water upward from the roots;
- 2) a leading global water technology company.

We're 12,000 people unified in a common purpose: creating innovative solutions to meet our world's water needs. Developing new technologies that will improve the way water is used, conserved, and re-used in the future is central to our work. We move, treat, analyze, and return water to the environment, and we help people use water efficiently, in their homes, buildings, factories and farms. In more than 150 countries, we have strong, long-standing relationships with customers who know us for our powerful combination of leading product brands and applications expertise, backed by a legacy of innovation.

For more information on how Xylem can help you, go to xylem.com.



Headquarters

LOWARA S.r.l. Unipersonale
Via Vittorio Lombardi 14
36075 Montecchio Maggiore - Vicenza - Italy
Tel. (+39) 0444 707111 - Fax (+39) 0444 492166
e-mail: lowara.mkt@xylem.com
web: www.lowara.com - www.completewatersystems.com

LOWARA reserves the right to make modification without prior notice.
LOWARA is a trademark of Xylem Inc. or one of its subsidiaries.