

**60 Hz**



# SCUBA, GS Series

4" - 5" SUBMERSIBLE  
ELECTRIC PUMPS

**SCUBA - GS SERIES  
HYDRAULIC PERFORMANCE RANGE AT 60 Hz**

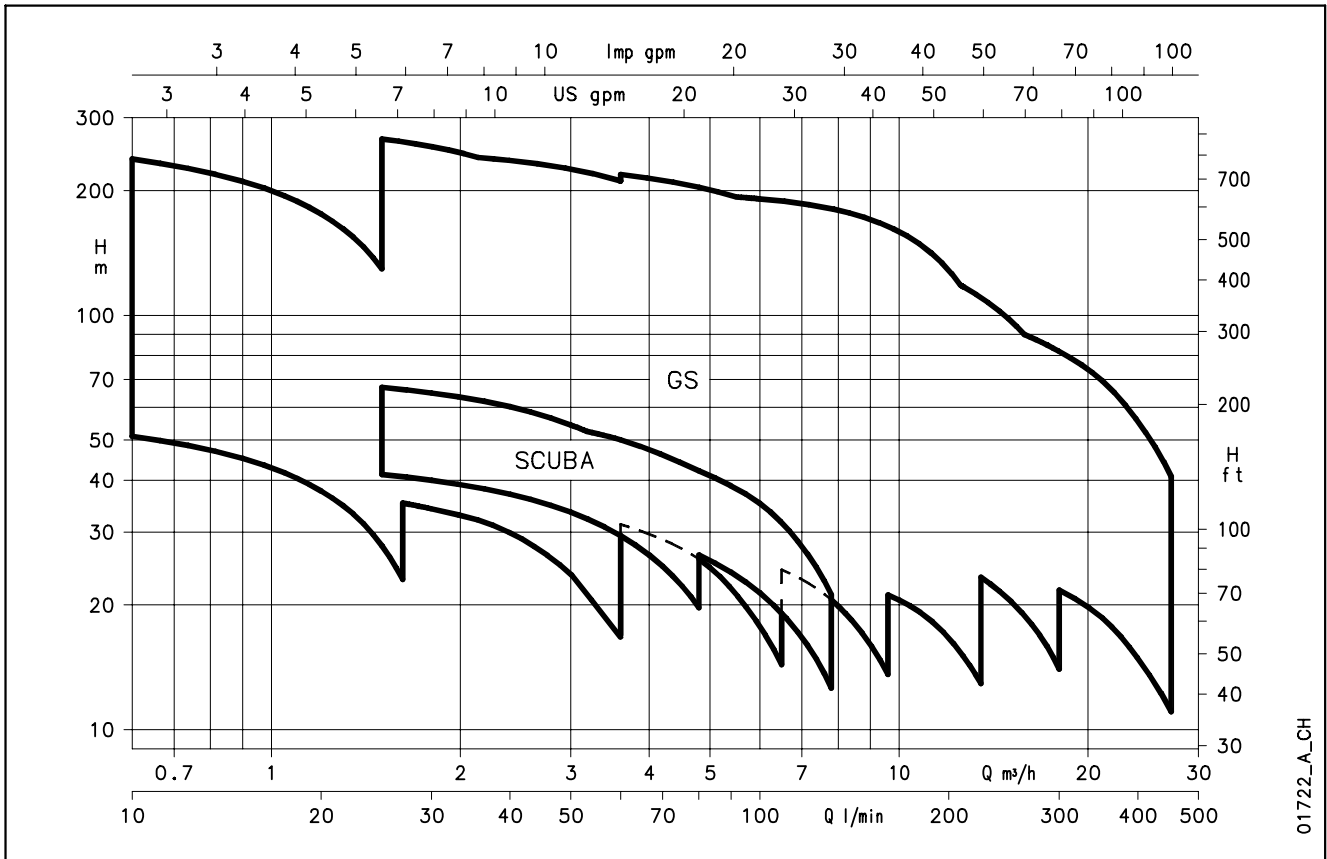

01722\_A\_CH

## **CONTENTS**

Scuba series specifications .....	<b>5</b>
Scuba series, hydraulic performance range at 60 Hz .....	<b>9</b>
Scuba series, dimensions and weights .....	<b>10</b>
GS series specifications .....	<b>13</b>
GS series, hydraulic performance range at 60 Hz .....	<b>17</b>
GS series, dimensions and weights .....	<b>18</b>
Motors 4OS series .....	<b>37</b>
Motors L4C series .....	<b>43</b>
Accessories .....	<b>49</b>
Technical Appendix .....	<b>65</b>



**Close-coupled  
Submersible  
Electric  
Pumps**

**SCUBA Series  
60 Hz**



**MARKET SECTORS**

CIVIL, AGRICULTURAL, INDUSTRIAL.

**APPLICATIONS**

- Water supply from primary water supply tanks or reservoirs, 6" wells, basins and watercourses.
- Sprinkler irrigation systems.
- Pressure boosting with pump directly inserted in tank or well, to avoid suction problems and noise.

**SPECIFICATIONS**

**PUMP**

- **Delivery:** up to 8 m<sup>3</sup>/h.
- **Head:** up to 75 m.
- Maximum overall **diameter** of electric pump: 128 mm.
- **Maximum** immersion depth: 20 m.
- **Maximum** permissible quantity of suspended sand: 25 g/m<sup>3</sup>.
- **Passes** solids up to 2,5 mm.
- **Delivery** port: Rp 1 1/4.
- **Motor power** : 0,75 to 1,1 kW.

**MOTOR**

- **Single-phase version:**  
220-240 V, 60 Hz.
- With built-in automatic reset overload protection.
- With built-in capacitor.
- **Three-phase version:**  
220-230 / 380-415 V, 60 Hz;  
overload protection to be provided by user and installed in the control panel (see electric panel section).
- Maximum supply **voltage variations:** ±10%.
- **Classe F** insulation.
- Can also operate in **horizontal position.**

- Maximum number of **starts per hour**, evenly distributed:  
25 for motors up to 0,9 kW.  
20 for motors 1,1 kW.
- Maximum **temperature** of water in contact with the motor: **40°C** (continuous use).

**MANUFACTURING  
FEATURES**

Single-phase range with pre-assembled float switch (SCUBA G series).

On request, different voltages and frequencies.

- AISI 304 stainless steel impellers available on request.

**CONSTRUCTION  
CHARACTERISTICS**

- Close-coupled, multiple impeller submersible electric pump.  
The liquid end is located underneath the electric motor, which is cooled by the pumped liquid.
- Impellers are radial centrifugal type, made of technopolymer.
- AISI 304 stainless steel diffusers.
- Outer sleeve, motor casing, suction screen and shaft extension are made of AISI 304 stainless steel.
- **Dry motor.**  
The electric motor is protected by a double seal system with an oil chamber. The silicon carbide mechanical seal, highly resistant to abrasion and wear, together with the second mechanical seal, lubricated thanks to the special configuration of the oil chambers, guarantee long-lasting reliability. The oil used is according to standard for oils in contact with foodstuffs (F.D.A. - FOOD AND DRUG ADMINISTRATION).

- Innovative**
- Compact**
- With Double seal system**
- Easy to install**

## SCUBA SERIES PUMP SECTION AND LIST OF MAIN COMPONENTS

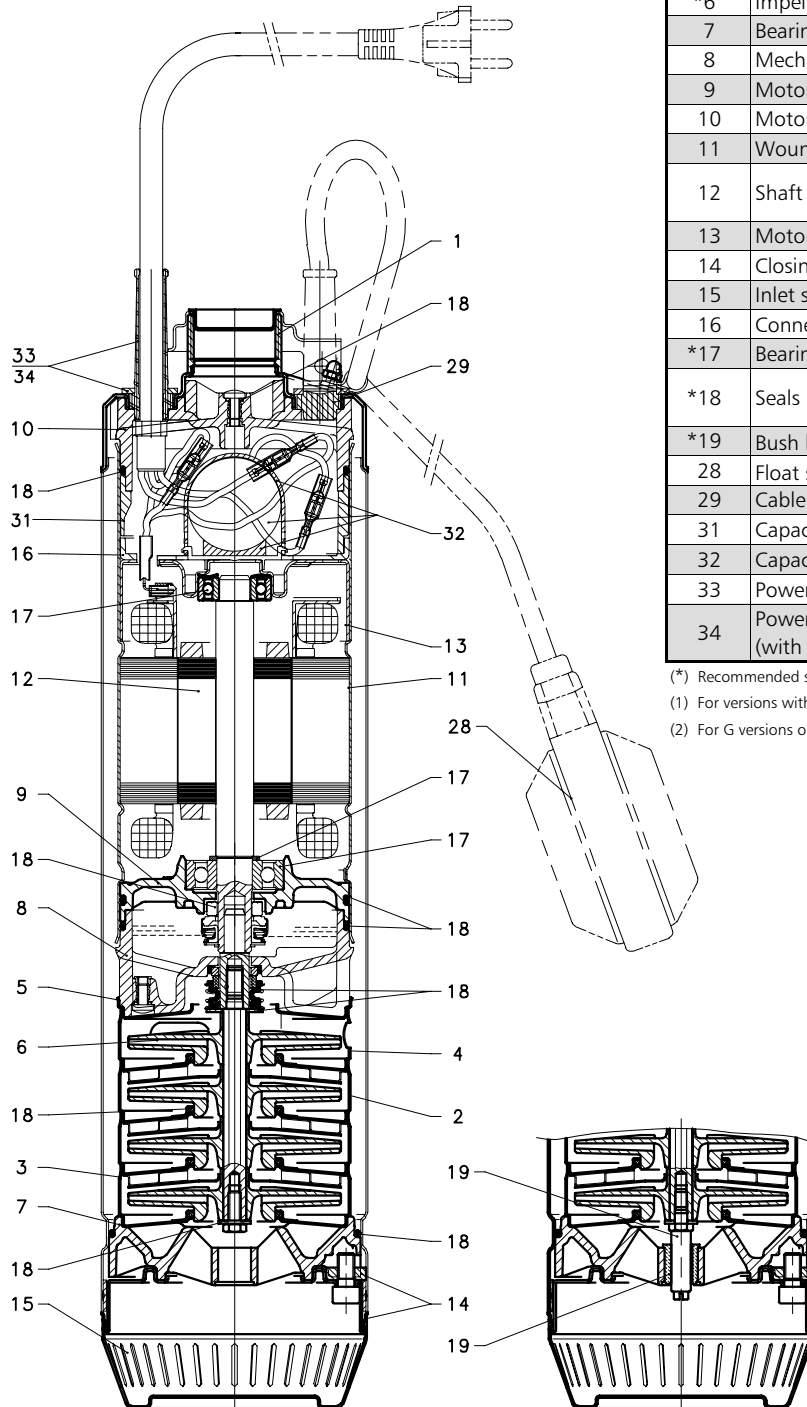

REF. N.	DESCRIPTION
1	Outer sleeve
*2	Diffuser
*3	Initial bowl
*4	Final diffuser
*5	Final bowl
*6	Impeller
7	Bearing spider
8	Mech seal housing
9	Motor lower bearing bracket
10	Motor head
11	Wound stator
12	Shaft kit (motor pump shaft + bearings)
13	Motor upper bearing bracket
14	Closing flange kit
15	Inlet strainer
16	Connection container
*17	Bearings kit
*18	Seals kit
*19	Bush kit <sup>(1)</sup>
28	Float switch kit <sup>(2)</sup>
29	Cable entry plug kit
31	Capacitor housing spacer
32	Capacitor
33	Power cable three-phase kit
34	Power cable single-phase kit (with plug)

(\* Recommended spare parts scuba-2p50-en\_b\_tp

(1) For versions with more than 4 impellers

(2) For G versions only

## SCUBA SERIES TABLE OF MATERIALS

NAME	MATERIAL	REFERENCE STANDARDS	
		EUROPE	USA
Sleeve with head	Stainless steel	EN 10088-1-X5CrNi18-10 (1.4301)	AISI 304
Upper bearing support	Stainless steel	EN 10088-1-X5CrNi18-10 (1.4301)	AISI 304
Sleeve with wound stator	Stainless steel	EN 10088-1-X5CrNi18-10 (1.4301)	AISI 304
Strainer	Stainless steel	EN 10088-1-X5CrNi18-10 (1.4301)	AISI 304
Shaft extension	Stainless steel	EN 10088-1-X5CrNiMo17-12-2 (1.4401)	AISI 316
Screws	Stainless steel	EN 10088-1-X5CrNi18-10 (1.4301)	AISI 304
Impeller	Noryl®		
Diffuser	Stainless steel	EN 10088-1-X5CrNi18-10 (1.4301)	AISI 304
Head	PPS Ryton®		
Lower head	PPS Ryton®		
Lower bearing support	Die-cast aluminium		
Bush support	PPS Ryton®		
Bush bearing	Laripur®		
Elastometers	Nitrile rubber (NBR)		
External mechanical seal	Silicon carbide		
Internal mechanical seal (fixed part)	Steatite		
Internal mechanical seal (rotary part)	Carbo-graphite		

scuba-sc2-sc4-2p60\_c\_tm

## SCUBA SERIES IDENTIFICATION CODES

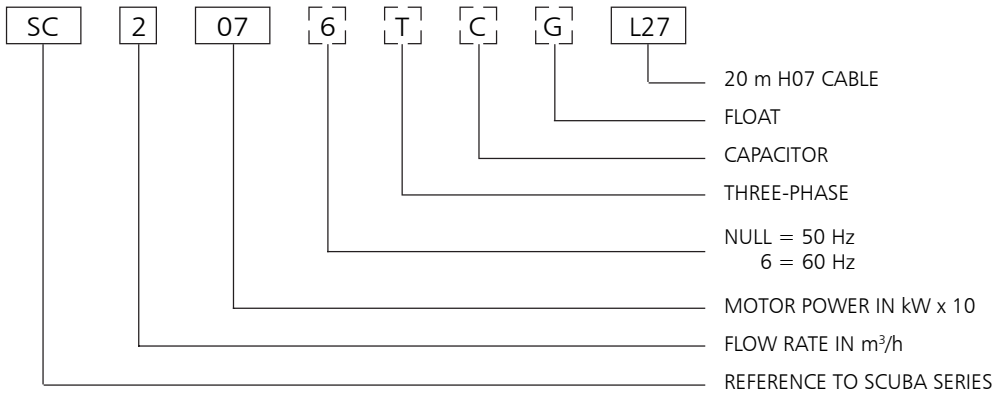

EXAMPLE : SC2076CGL27

SCUBA PUMP :  
 FLOW RATE 2 m<sup>3</sup>/h; SINGLE-PHASE; 0,75 kW; 60 Hz;  
 INTERNAL CAPACITOR; FLOAT; 20 m of H07 CABLE

## SINGLE-PHASE RATING PLATE

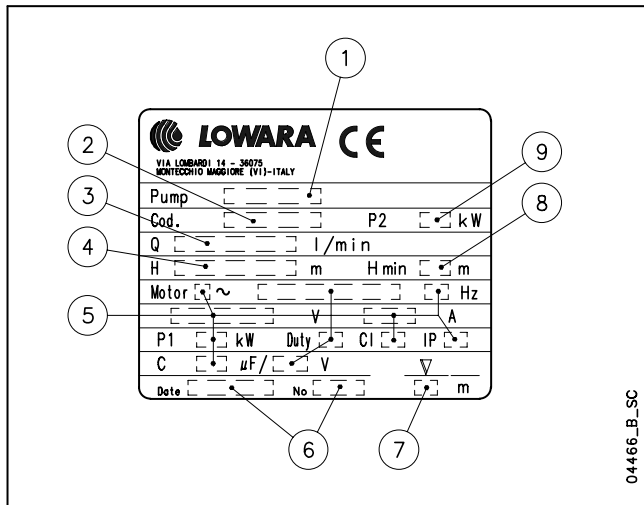

## LEGEND

- 1 - Electric pump type
- 2 - Code
- 3 - Delivery range
- 4 - Head range
- 5 - Characteristics motor
- 6 - Manufacturing data and serial number
- 7 - Maximum immersion depth
- 8 - Minimum head
- 9 - Rated output

## THREE-PHASE RATING PLATE

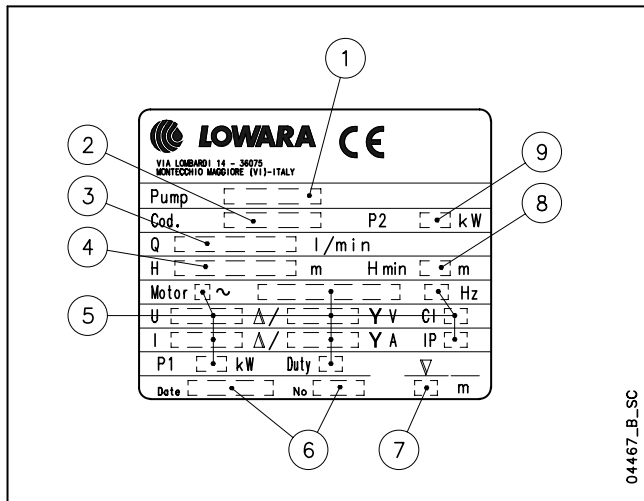



**SCUBA SERIES  
HYDRAULIC PERFORMANCE RANGE AT 60 Hz**

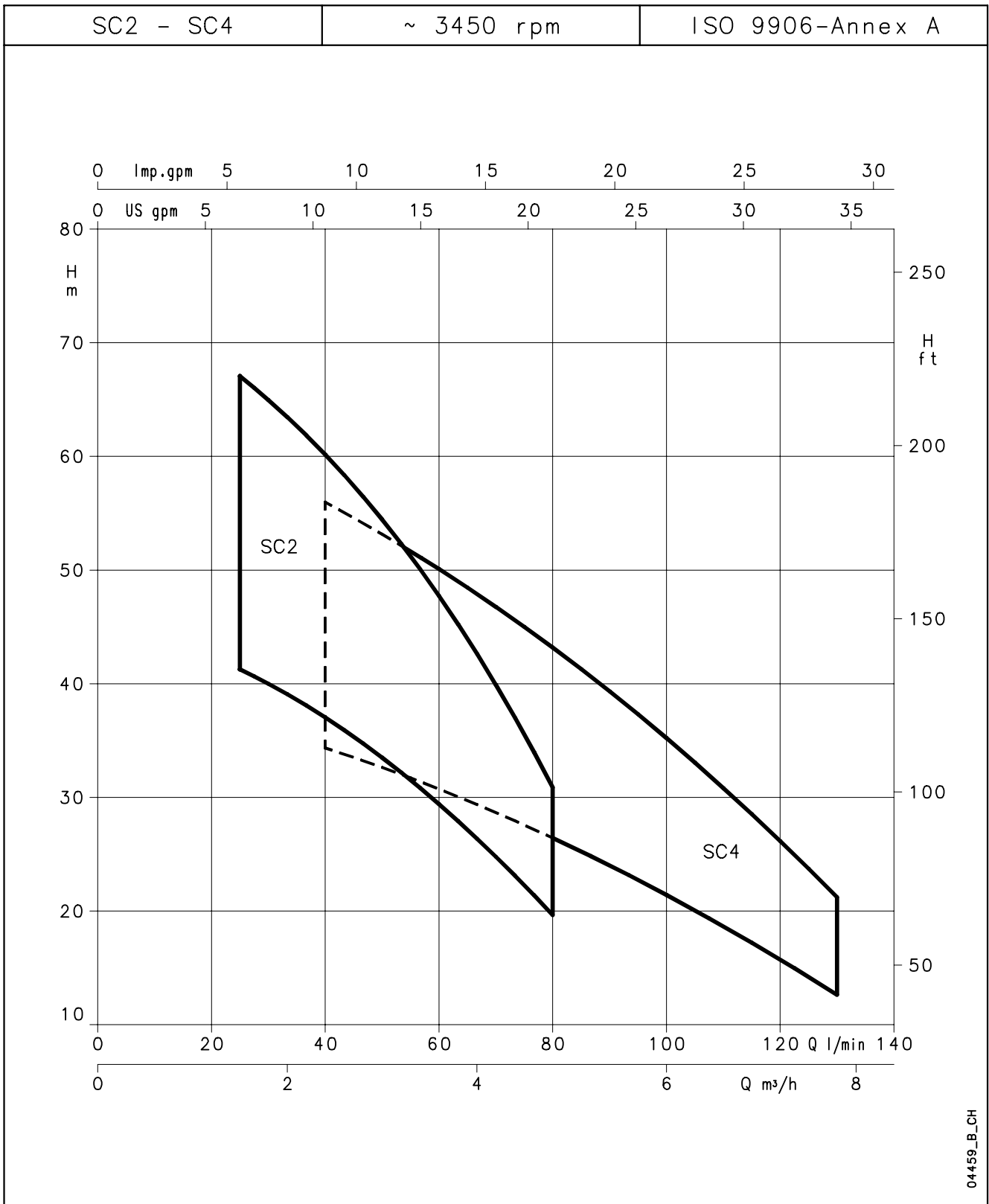

## SCUBA SERIES DIMENSIONS AND WEIGHTS AT 60 Hz

PUMP TYPE		N. OF STAGES	DIMENSIONS L mm	WEIGHT kg
SINGLE-PHASE	THREE-PHASE			
SC2076C	SC2076T	3	516	17,5
SC2096C	SC2096T	4	541	16,3
SC2116C	SC2116T	5	586	17
SC4076C	SC4076T	3	516	17
SC4096C	SC4096T	4	541	16
SC4116C	SC4116T	5	586	18

scuba-sc2-sc4-2p60\_c\_td

PUMP TYPE	CROSS SECTION	CABLE TYPE	CABLE LENGTH
SC2076C	3G1	H07RN-F	10 m or 20 m
SC2096C	3G1.5	H07RN-F	
SC2116C	3G1.5	H07RN-F	
SC4076C	3G1	H07RN-F	
SC4096C	3G1.5	H07RN-F	
SC4116C	3G1.5	H07RN-F	
SC2076T	4G1	H07RN-F	
SC2096T	4G1	H07RN-F	
SC2116T	4G1	H07RN-F	
SC4076T	4G1	H07RN-F	
SC4096T	4G1	H07RN-F	
SC4116T	4G1	H07RN-F	

scuba-sc2-sc4-2p60\_c\_tc

Single-phase version available with pre-assembled float switch (SCUBA CG)

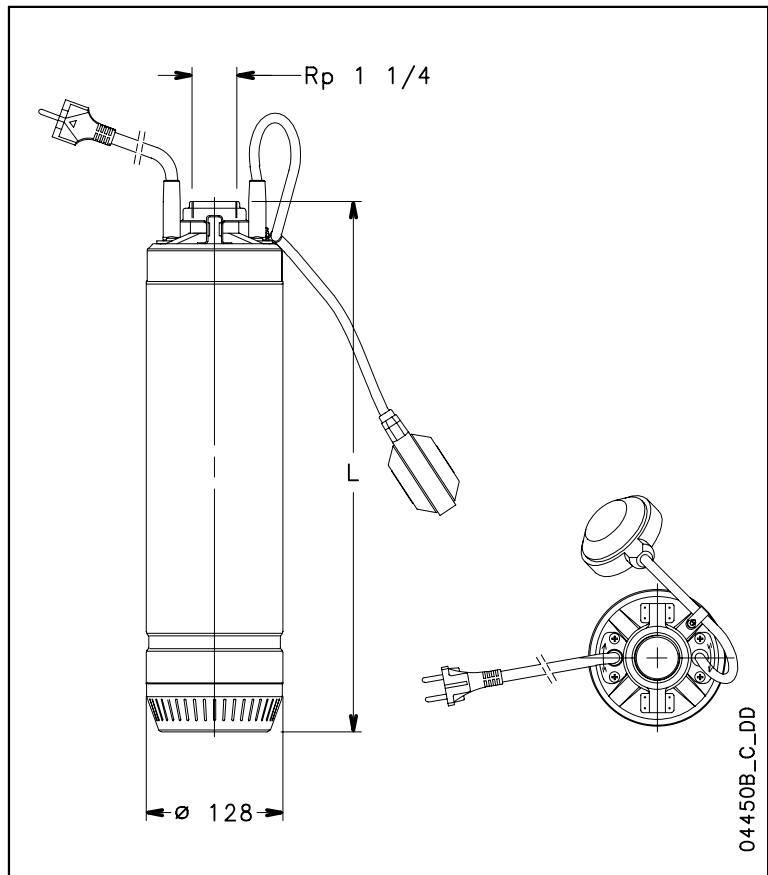

04450B\_C\_DD

## HYDRAULIC PERFORMANCE TABLE AT 60 Hz

PUMP TYPE	RATED POWER		Q = DELIVERY											
			l/min	0	25	30	40	50	60	80	100	115	130	
			m <sup>3</sup> /h	0	1,5	1,8	2,4	3	3,6	4,8	6	6,9	7,8	
		H = TOTAL HEAD METERS COLUMN OF WATER												
	kW	HP												
SC2076C - SC2076T	0,75	1	45,2	41,3	40,0	37,0	33,5	29,4	19,7					
SC2096C - SC2096T	0,9	1,2	60,0	53,8	52,1	48,2	43,6	38,3	25,1					
SC2116C - SC2116T	1,1	1,5	75,0	67,1	65,0	60,2	54,4	47,7	30,9					
SC4076C - SC4076T	0,75	1	39,3			34,3	32,6	30,7	26,4	21,4	17,2	12,6		
SC4096C - SC4096T	0,9	1,2	52,3			45,3	43,0	40,4	34,6	27,9	22,3	16,3		
SC4116C - SC4116T	1,1	1,5	64,8			56,0	53,2	50,1	43,2	35,2	28,5	21,2		

scuba-sc2-sc4-2p60\_c\_th

PUMP TYPE	INPUT POWER*	INPUT CURRENT*	CAPACITOR
SINGLE-PHASE		220-230 V	
	kW	A	µF / 450 V
SC2076C	0,95	4,47	25
SC2096C	1,17	5,40	25
SC2116C	1,41	6,43	30
SC4076C	0,97	4,52	25
SC4096C	1,15	5,31	25
SC4116C	1,49	6,80	30

\*Maximum value in specified range

PUMP TYPE	INPUT POWER*	INPUT CURRENT*	INPUT CURRENT*
THREE-PHASE		220-230 V	380-400 V
	kW	A	A
SC2076T	0,85	2,99	1,73
SC2096T	1,08	3,52	2,03
SC2116T	1,32	4,10	2,37
SC4076T	0,87	3,03	1,75
SC4096T	1,06	3,46	2,00
SC4116T	1,40	4,30	2,48

scuba-sc2-sc4-2p60\_c\_te

**SCUBA SERIES  
OPERATING CHARACTERISTICS AT 60 Hz**

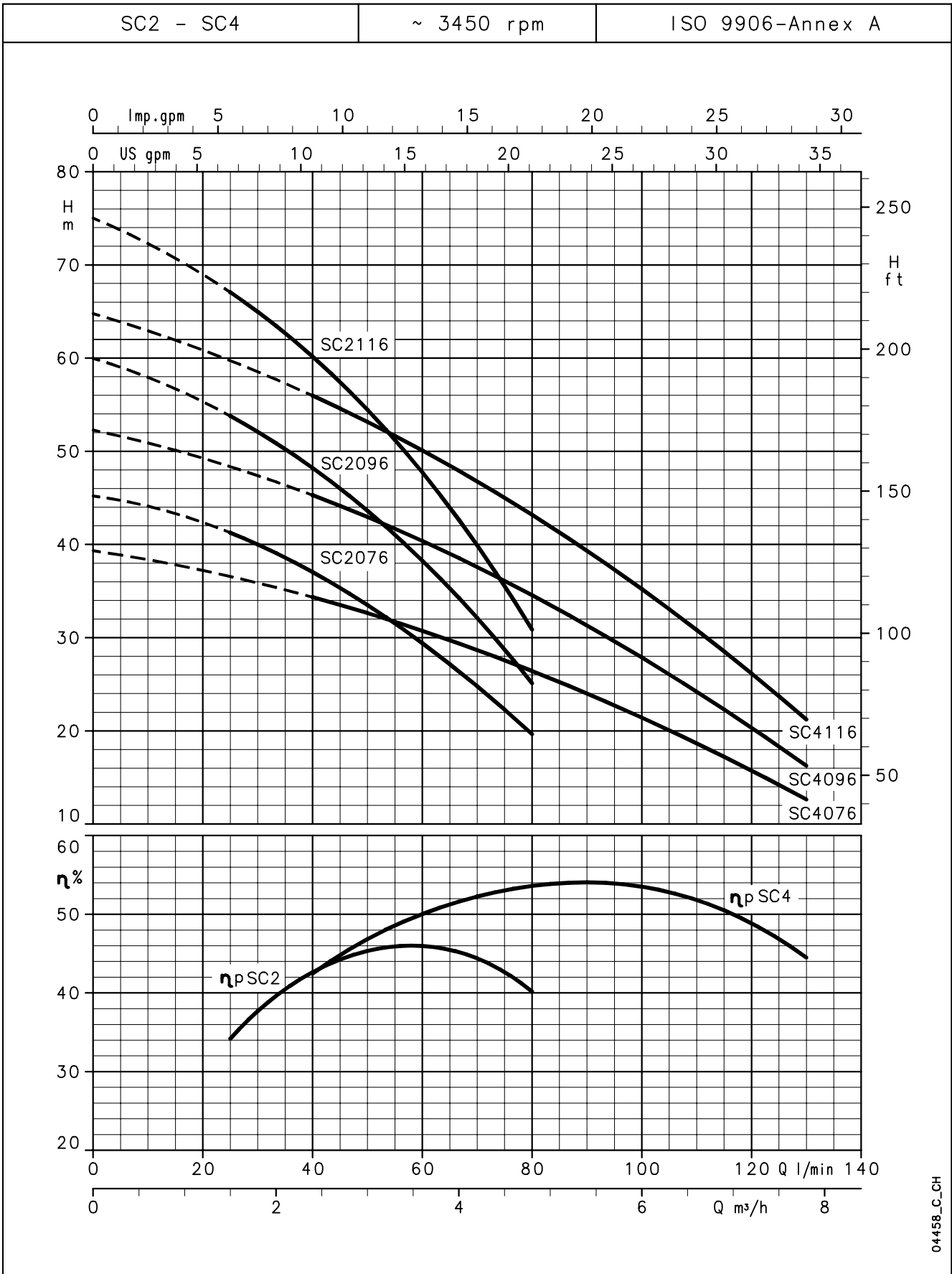

These performances are valid for liquids with density  $\rho = 1.0 \text{ Kg/dm}^3$  and kinematic viscosity  $\nu = 1 \text{ mm}^2/\text{sec}$ .

**EXAMPLE OF INSTALLATION OF A SCUBA PUMP  
CONTROLLED BY AN INVERTER  
(HYDROVAR® WATERCOOLED)**

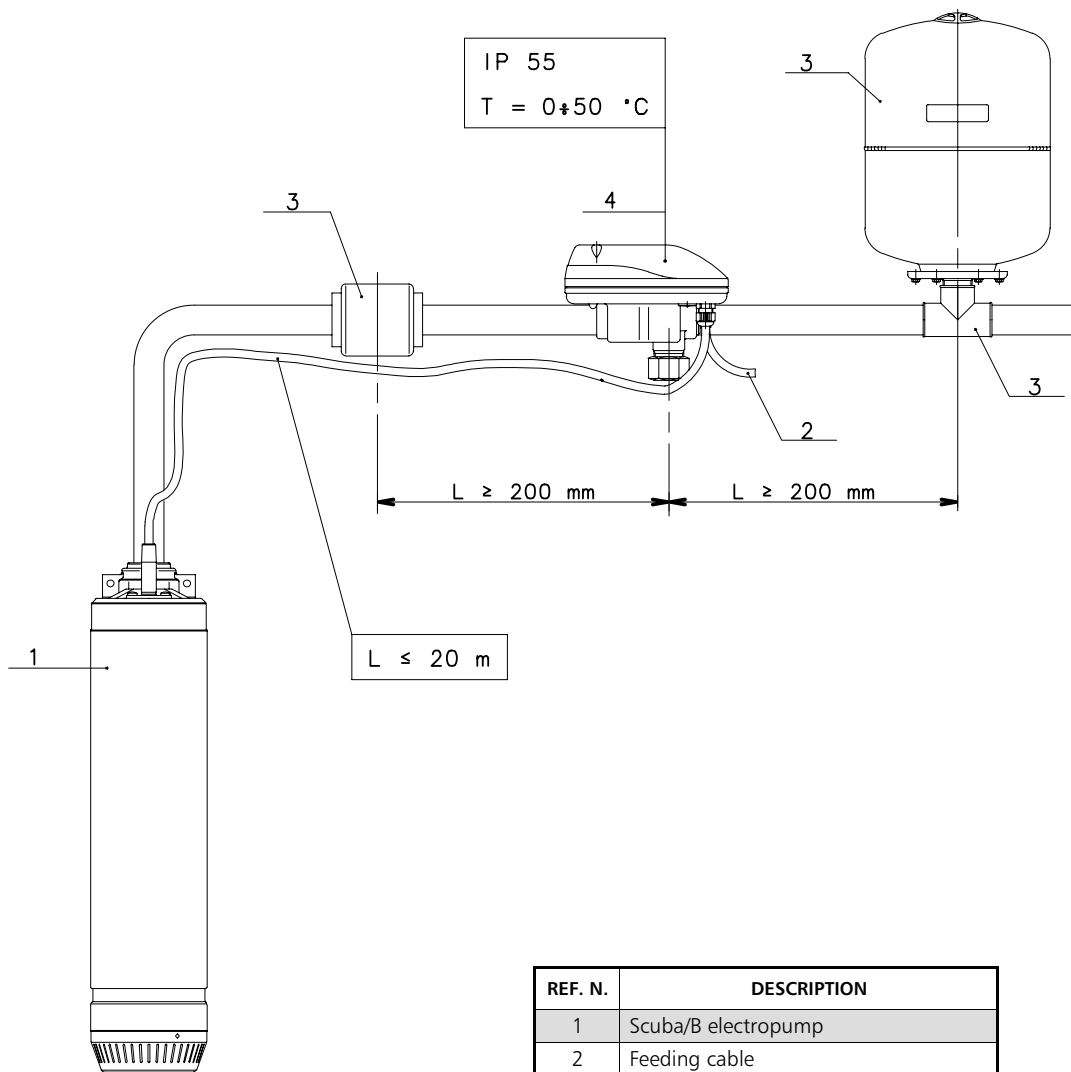

REF. N.	DESCRIPTION
1	Scuba/B electropump
2	Feeding cable
3	Hydraulic kit HVW
4	Hydrovar® Watercooled inverter

scuba-hvw-2p50-en\_a\_tp

## 4" Submersible Pumps

### GS Series 60 Hz



- Compact**
- Sturdy**
- Abrasion resistant**
- All components are F.D.A. approved**
- Floating impellers**

### MARKET SECTORS

CIVIL, AGRICULTURAL, INDUSTRIAL.

### APPLICATIONS

- Water supply.
- Sprinkler irrigation.
- Pressure boosting.
- Fire-fighting.

### SPECIFICATIONS

#### PUMP

- **Delivery:** up to 27 m<sup>3</sup>/h.
- **Head:** up to 300 m.
- Maximum pump overall **diameter** (cable cover included): 99 mm.
- **Maximum** immersion depth: 150 m (with 4OS motor). 300 m (with L4C motor).
- **Maximum** permissible quantity of sand: 150 g/m<sup>3</sup>.
- 1GSL - 2GS - 4GS - 6GS **versions** Rp 1 1/4 delivery port.
- 8GS - 12GS - 16GS **versions** Rp 2 delivery port.
- Motor **power** : from 0,37 to 7,5 kW.

#### MOTOR

- **4OS single-phase version:** from 0,37 to 2,2 kW 220-230 V, 60 Hz. from 0,37 to 1,1 kW 110-115 V, 60 Hz.
- **4OS three-phase version:** from 0,37 to 7,5 kW 220-230 V, 60 Hz. from 0,37 to 7,5 kW 380 V, 60 Hz.
- **L4C single-phase version:** from 0,37 to 4 kW 220-230 V, 60 Hz. from 0,37 to 0,75 kW 110-115 V, 60 Hz.
- **L4C three-phase version:** from 0,37 to 5,5 kW 220-230 V, 60 Hz. from 0,37 to 7,5 kW 380 V, 60 Hz.
- Overload protection to be provided by user and installed in the control panel (see electric panel section).
- Maximum supply **voltage variations:** 220V -6%; 230 +6% (4OS). 380V ±10% (4OS). ±6% (L4C).
- Maximum number of **starts per hour** evenly distributed: 30 (4OS), 40 (L4C).

#### Horizontal operation:

- 4OS up to 2,2 kW.
- L4C up to 7,5 kW.
- Maximum **temperature** of water in contact with motor: **35°C** (4OS), **35°C** (L4C).

### CONSTRUCTION CHARACTERISTICS PUMP

- Abrasion-resistant construction. The front wear plate, combined with the floating impellers, ensures optimum resistance to abrasion.
- The upper and lower supports are made of precision-cast stainless steel, ensuring resistance to corrosion, durability and a sturdy coupling to the motor.
- The hexagonal pump shaft guarantees an effective impeller driving.
- A stainless steel non-return valve is fitted in the discharge to prevent any back flow of water and alleviate any water hammer to the pump, thus safeguarding impellers and diffusers.
- The GS series pumps can be coupled to either the 4OS or L4C motors.

#### MOTOR

For the motor characteristics, please see the relevant motor section.

### OPTIONAL FEATURES

- Different voltages and frequencies.

## GS SERIES

### TABLE OF MATERIALS

NAME	MATERIAL	REFERENCE STANDARDS	
		EUROPE	USA
Delivery port	Stainless steel	EN 10213-4-GX5CrNi19-10 (1.4308)	CF-8 ASTM A743
Valve cap	Stainless steel	EN 10088-1-X5CrNi18-10 (1.4301)	AISI 304
Valve support	Stainless steel	EN 10088-1-X5CrNi18-10 (1.4301)	AISI 304
Valve gasket	Nitrile (NBR)		
Valve locking ring	Stainless steel	DIN 17006 - X5CrNi18-7 (1.4319)	AISI 302
Upper support	Lexan®		
Bush bearing	Laripur®		
Split ring	Stainless steel	EN 10088-1-X5CrNiMo17-12-2 (1.4401)	AISI 316
Diffuser	Lexan®		
Impeller	Lexan®		
Stage housing	Stainless steel	EN 10088-1-X5CrNi18-10 (1.4301)	AISI 304
Shim	Stainless steel	EN 10088-1-X5CrNi18-10 (1.4301)	AISI 304
Pump shaft	Stainless steel	EN 10088-1-X5CrNi18-10 (1.4301)	AISI 304
Outer sleeve	Stainless steel	EN 10088-1-X5CrNi18-10 (1.4301)	AISI 304
Spacer	Stainless steel	EN 10088-1-X5CrNi18-10 (1.4301)	AISI 304
Filter	Stainless steel	EN 10088-1-X5CrNi18-10 (1.4301)	AISI 304
Adapter	Stainless steel	EN 10213-4-GX5CrNi19-10 (1.4308)	CF-8 ASTM A743
Coupling	Stainless steel	EN 10088-1-X5CrNi18-10 (1.4301)	AISI 304
Cable cover screw	Stainless steel	EN 10088-1-X5CrNiMo17-12-2 (1.4401)	AISI 316
Cable cover	Stainless steel	EN 10088-1-X5CrNi18-10 (1.4301)	AISI 304

Gs4-2p60-en\_d\_tm

## GS SERIES IDENTIFICATION CODE (PUMP)

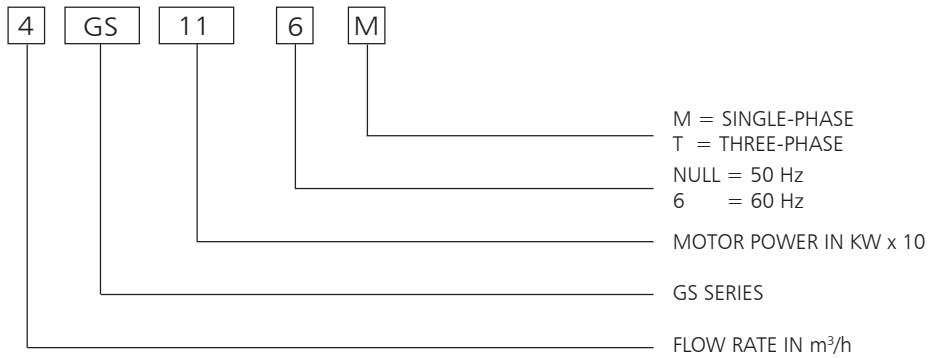

EXAMPLE : 4GS116M  
GS pump series, flow rate of 4 m<sup>3</sup>/h, rated motor power 1,1 kW,  
60 Hz version, single-phase.

## IDENTIFICATION CODE (ELECTRIC PUMP)

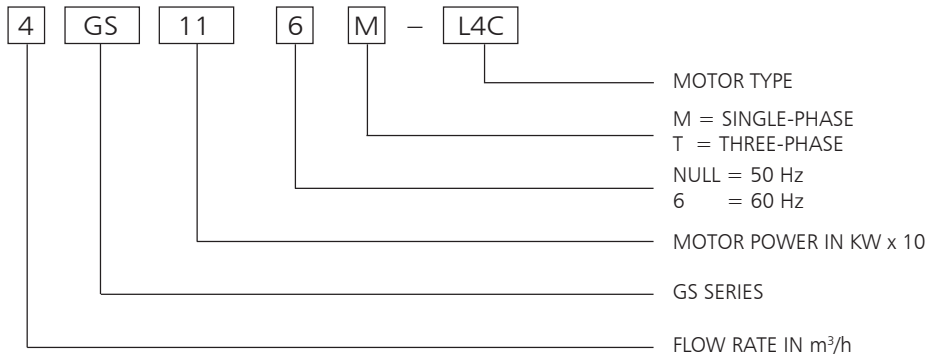

EXAMPLE : 4GS116M-L4C  
GS electric pump series, flow rate of 4 m<sup>3</sup>/h, rated motor power 1,1 kW,  
60 Hz version, single-phase, coupled to a 4" motor L4C.

**GS SERIES  
RATING PLATE (PUMP)**

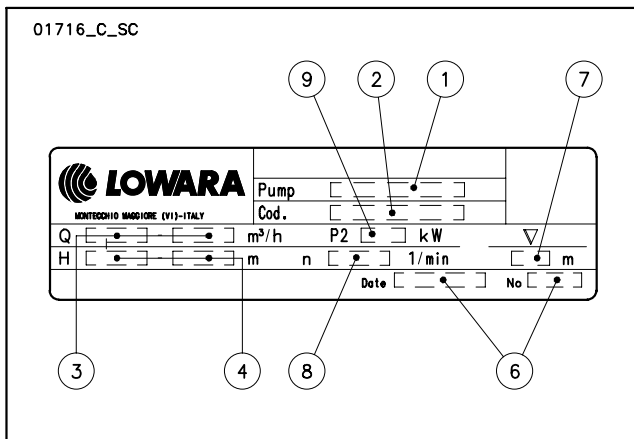

**RATING PLATE (ELECTRIC PUMP)**

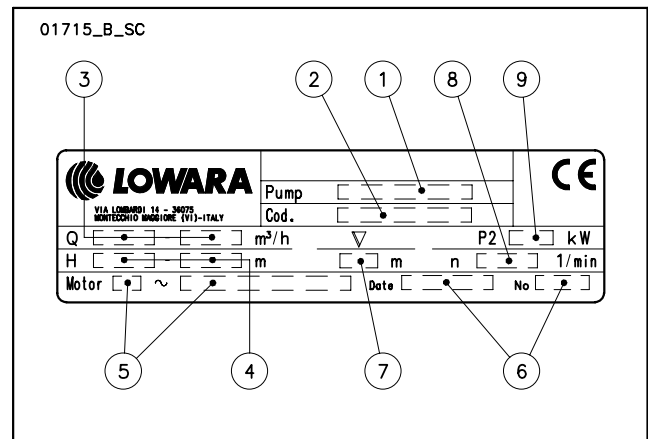

**LEGEND**

- 1 - Pump / electric pump type
- 2 - Code
- 3 - Delivery range
- 4 - Head range
- 5 - Characteristics motor

- 6 - Manufacturing data and serial number
- 7 - Maximum immersion depth
- 8 - Speed
- 9 - Rated output

**RATING PLATE  
(SINGLE-PHASE MOTOR)**

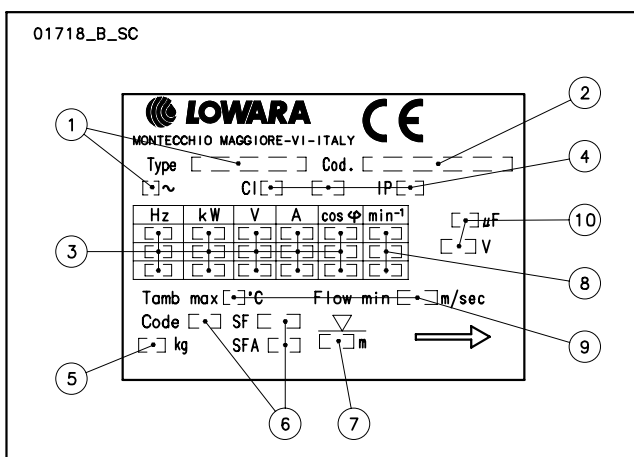

**RATING PLATE  
(THREE-PHASE MOTOR)**

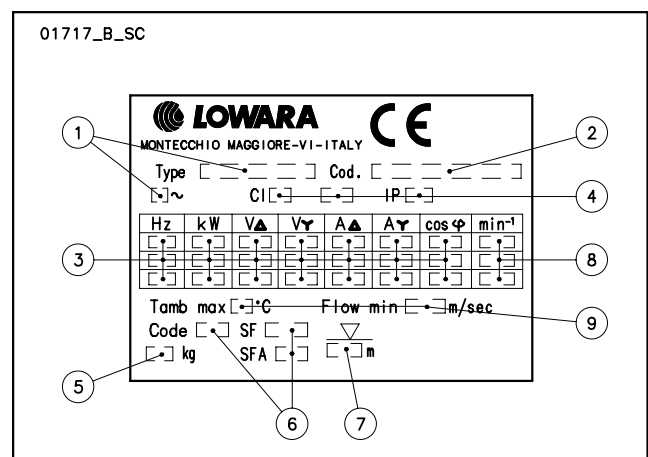

**LEGEND**

- 1 - Motor type
- 2 - Code
- 3 - Electrical data
- 4 - Characteristics motor
- 5 - Motor weight

- 6 - Service factors
- 7 - Maximum immersion depth
- 8 - Speed
- 9 - Temperature and speed water
- 10 - Capacitor data



**GS SERIES  
HYDRAULIC PERFORMANCE RANGE AT 60 Hz**

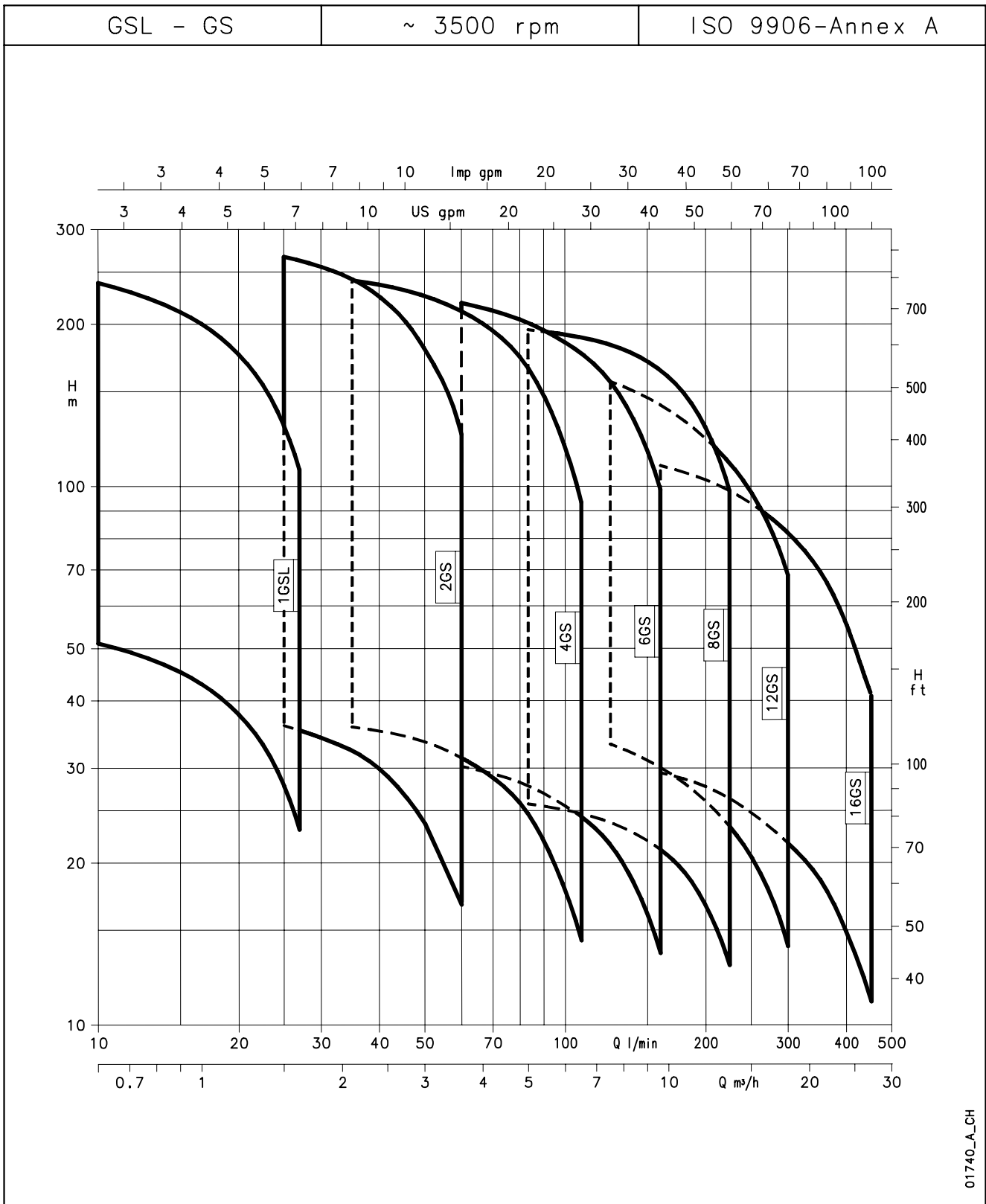

01740\_A\_CH

## 1GSL SERIES OPERATING CHARACTERISTICS AT 60 Hz

PUMP TYPE	N. OF STAGES	MOTOR POWER		Q = DELIVERY						
				l/min	0	10	15	20	25	27
				m <sup>3</sup> /h	0	0,6	0,9	1,2	1,5	1,62
				H = TOTAL HEAD METRES COLUMN OF WATER						
1GSL036	6	0,37	0,5	58	51,1	45	38	28	23	
1GSL056	10	0,55	0,75	96	85,2	75	63	46	38,3	
1GSL076	14	0,75	1	135	119	105	88	65	53,6	
1GSL116	20	1,1	1,5	192	171	151	126	93	76,6	
1GSL156	28	1,5	2	269	239	211	176	130	107	

1gsl-2p60-en\_b\_th

## 1GSL..4OS SERIES DIMENSIONS AND WEIGHTS

ELECTRIC PUMP TYPE	N. OF STAGES	DNM	DIMENSIONS (mm)		PUMP WEIGHT kg	ELECTRIC PUMP WEIGHT kg
			L1	L		
1GSL036M-4OS	6	Rp 1 1/4	263	616	2,6	10
1GSL056M-4OS	10	Rp 1 1/4	332	685	3,4	11,5
1GSL076M-4OS	14	Rp 1 1/4	402	780	4,2	13,5
1GSL116M-4OS	20	Rp 1 1/4	507	920	5,2	16,5
1GSL156M-4OS	28	Rp 1 1/4	677	1125	6,7	19,5
1GSL036T-4OS	6	Rp 1 1/4	263	595	2,6	9,5
1GSL056T-4OS	10	Rp 1 1/4	332	685	3,4	11
1GSL076T-4OS	14	Rp 1 1/4	402	755	4,2	12,5
1GSL116T-4OS	20	Rp 1 1/4	507	885	5,2	14,5
1GSL156T-4OS	28	Rp 1 1/4	677	1090	6,7	18

1gsl-4os-2p60-en\_a\_td

## 1GSL..L4C SERIES DIMENSIONS AND WEIGHTS

ELECTRIC PUMP TYPE	N. OF STAGES	DNM	DIMENSIONS (mm)		PUMP WEIGHT kg	ELECTRIC PUMP WEIGHT kg
			L1	L		
1GSL036M-L4C	6	Rp 1 1/4	263	527	2,6	11,5
1GSL056M-L4C	10	Rp 1 1/4	332	616	3,4	13
1GSL076M-L4C	14	Rp 1 1/4	402	731	4,2	16
1GSL116M-L4C	20	Rp 1 1/4	507	896	5,2	19,5
1GSL156M-L4C	28	Rp 1 1/4	677	1086	6,7	22
1GSL036T-L4C	6	Rp 1 1/4	263	497	2,6	10,5
1GSL056T-L4C	10	Rp 1 1/4	332	596	3,4	12,5
1GSL076T-L4C	14	Rp 1 1/4	402	686	4,2	14
1GSL116T-L4C	20	Rp 1 1/4	507	851	5,2	17
1GSL156T-L4C	28	Rp 1 1/4	677	1066	6,7	21

1gsl-l4c-2p60-en\_a\_td

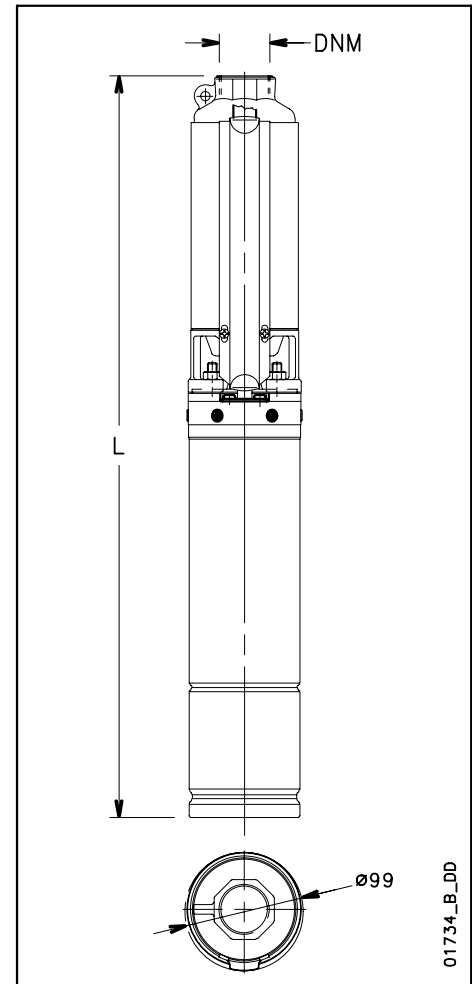
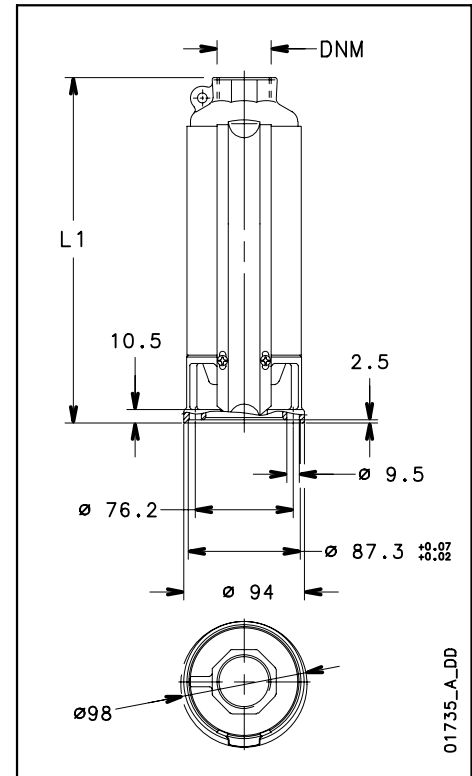

**1GSL SERIES  
OPERATING CHARACTERISTICS AT 60 Hz**

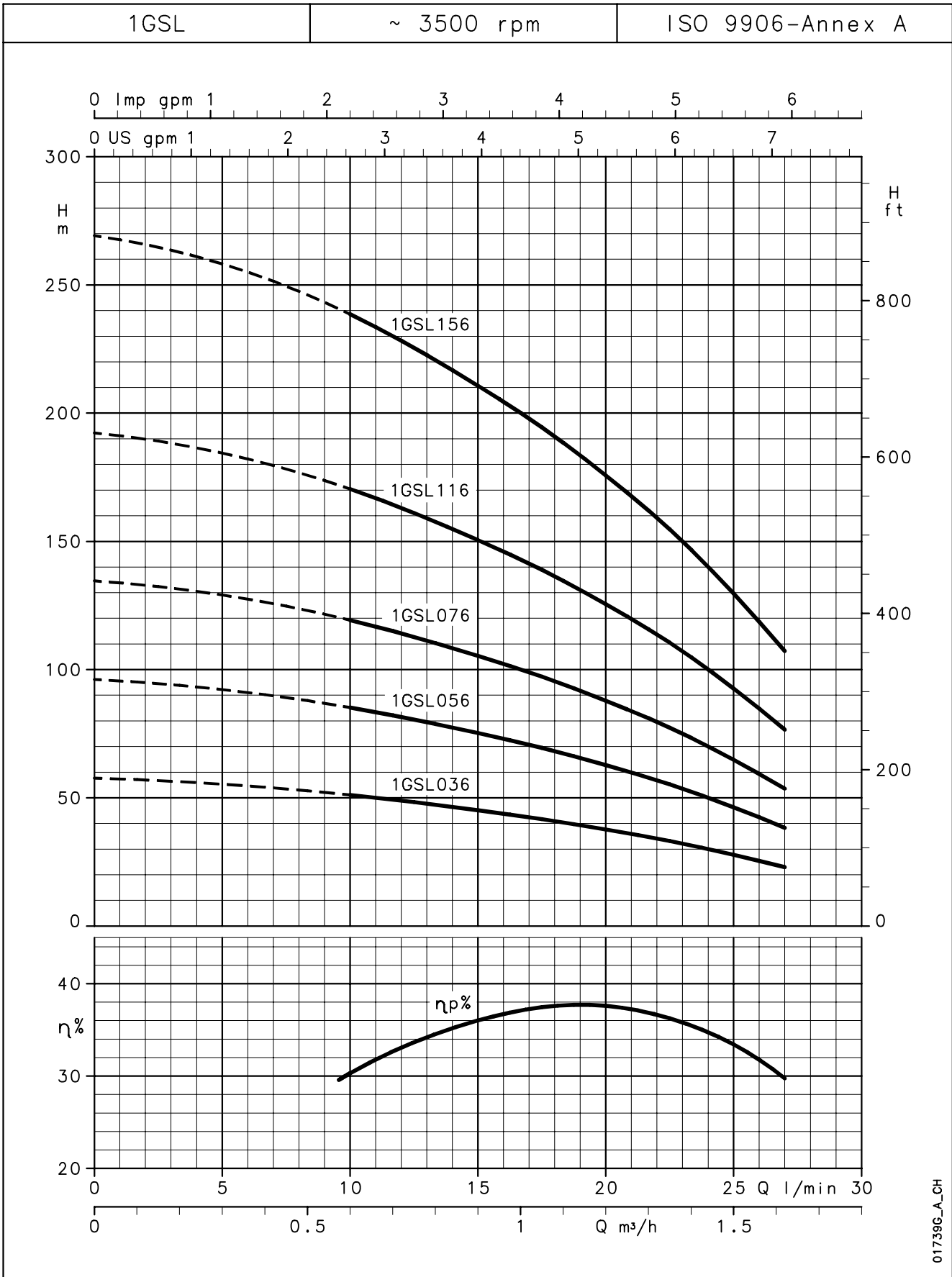

01739G\_A\_CH

These performances are valid for liquids with density  $\rho = 1.0 \text{ Kg/dm}^3$  and kinematic viscosity  $\nu = 1 \text{ mm}^2/\text{sec}$ .

## 2GS SERIES OPERATING CHARACTERISTICS AT 60 Hz

PUMP TYPE	N. OF STAGES	MOTOR POWER		Q = DELIVERY						
				H = TOTAL HEAD METRES COLUMN OF WATER						
				l/min	0	25	30	40	50	60
				m <sup>3</sup> /h	0	1,5	1,8	2,4	3	3,6
		kW	HP							
2GS036	4	0,37	0,5		39	36	34	30	24	16
2GS056	6	0,55	0,75		59	53	51	45	36	25
2GS076	8	0,75	1		79	71	68	60	48	33
2GS116	12	1,1	1,5		118	107	102	90	72	49
2GS156	16	1,5	2		158	142	137	119	96	66
2GS226	22	2,2	3		217	196	188	164	132	90
2GS306	30	3	4		296	267	256	224	179	123

2gs-2p60-en\_b\_th

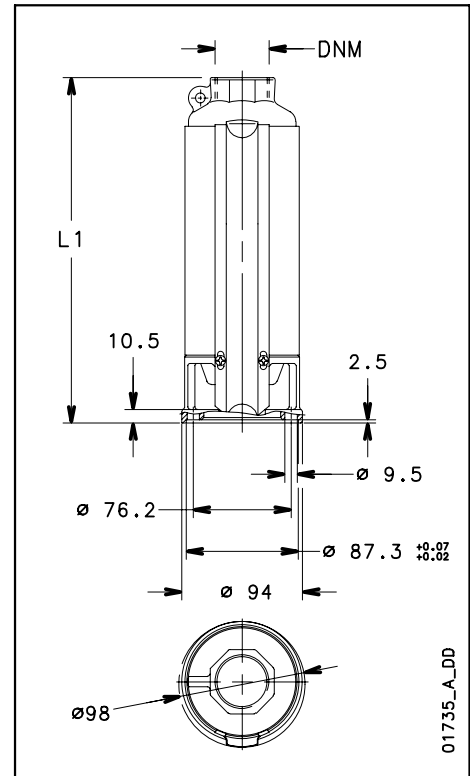

## 2GS..4OS SERIES DIMENSIONS AND WEIGHTS

ELECTRIC PUMP TYPE	N. OF STAGES	DNM	DIMENSIONS (mm)		PUMP WEIGHT kg	ELECTRIC PUMP WEIGHT kg
			L1	L		
			2GS036M-4OS	4		
2GS056M-4OS	6	Rp 1 1/4	263	616	2,8	11
2GS076M-4OS	8	Rp 1 1/4	298	676	3,1	12,5
2GS116M-4OS	12	Rp 1 1/4	367	780	3,9	15
2GS156M-4OS	16	Rp 1 1/4	437	885	4,6	17,5
2GS226M-4OS	22	Rp 1 1/4	542	1040	5,8	21
2GS036T-4OS	4	Rp 1 1/4	228	560	2,4	9,5
2GS056T-4OS	6	Rp 1 1/4	263	616	2,8	10,5
2GS076T-4OS	8	Rp 1 1/4	298	651	3,1	11
2GS116T-4OS	12	Rp 1 1/4	367	745	3,9	13
2GS156T-4OS	16	Rp 1 1/4	437	850	4,6	16
2GS226T-4OS	22	Rp 1 1/4	542	990	5,8	18,5
2GS306T-4OS	30	Rp 1 1/4	712	1160	7,6	26,5

2gs-4os-2p60-en\_a\_td

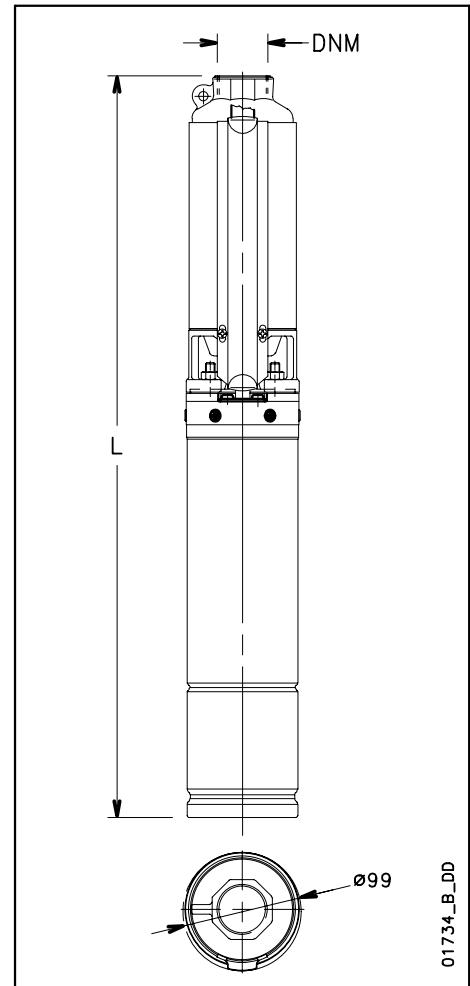

## 2GS..L4C SERIES DIMENSIONS AND WEIGHTS

ELECTRIC PUMP TYPE	N. OF STAGES	DNM	DIMENSIONS (mm)		PUMP WEIGHT kg	ELECTRIC PUMP WEIGHT kg
			L1	L		
			2GS036M-L4C	4		
2GS056M-L4C	6	Rp 1 1/4	263	547	2,8	12,5
2GS076M-L4C	8	Rp 1 1/4	298	627	3,1	15
2GS116M-L4C	12	Rp 1 1/4	367	756	3,9	18
2GS156M-L4C	16	Rp 1 1/4	437	846	4,6	20
2GS226M-L4C	22	Rp 1 1/4	542	991	5,8	24
2GS036T-L4C	4	Rp 1 1/4	228	462	2,4	10,5
2GS056T-L4C	6	Rp 1 1/4	263	527	2,8	11,5
2GS076T-L4C	8	Rp 1 1/4	298	582	3,1	13
2GS116T-L4C	12	Rp 1 1/4	367	711	3,9	16
2GS156T-L4C	16	Rp 1 1/4	437	826	4,6	18,5
2GS226T-L4C	22	Rp 1 1/4	542	951	5,8	21
2GS306T-L4C	30	Rp 1 1/4	712	1254	7,6	29

2gs-l4c-2p60-en\_a\_td

**2GS SERIES  
OPERATING CHARACTERISTICS AT 60 Hz**

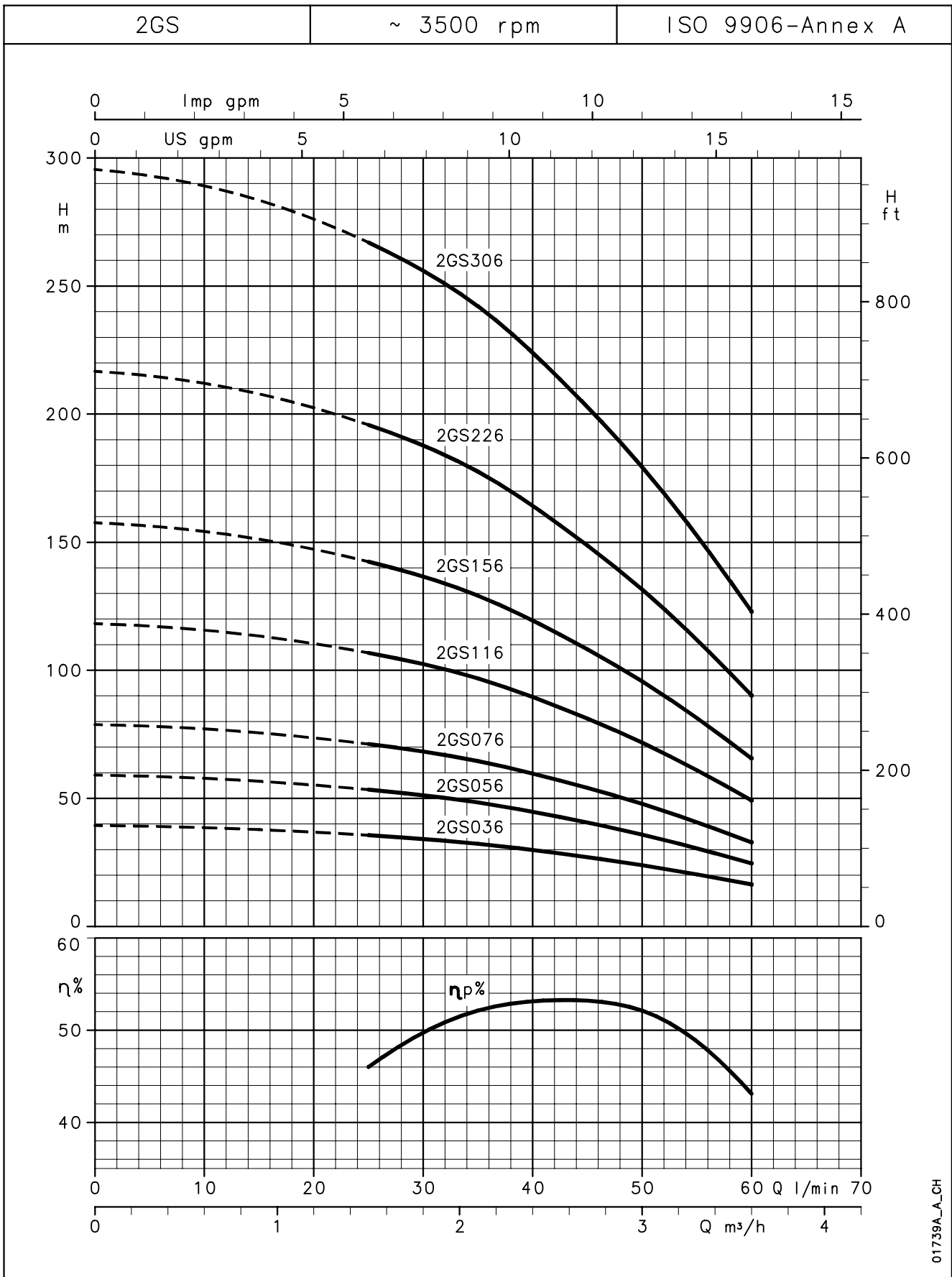

01739A\_A-CH

These performances are valid for liquids with density  $\rho = 1.0 \text{ Kg/dm}^3$  and kinematic viscosity  $\nu = 1 \text{ mm}^2/\text{sec}$ .

## 4GS SERIES OPERATING CHARACTERISTICS AT 60 Hz

PUMP TYPE	N. OF STAGES	MOTOR POWER		Q = DELIVERY						
				l/min	0	35	50	70	90	108
				m <sup>3</sup> /h	0	2,1	3	4,2	5,4	6,5
				H = TOTAL HEAD METRES COLUMN OF WATER						
4GS056	4	0,55	0,75	39	35,5	33	29	22	14	
4GS076	5	0,75	1	49	44,5	42	36	28	17	
4GS116	8	1,1	1,5	79	71	67	58	43	27	
4GS156	10	1,5	2	99	89	83	72	55	34	
4GS226	15	2,2	3	148	133	125	108	82	51	
4GS306	19	3	4	187	169	158	137	105	65	
4GS406	27	4	5,5	266	240	225	193	149	92	

4gs-2p60-en\_b\_th

## 4GS..4OS SERIES DIMENSIONS AND WEIGHTS

ELECTRIC PUMP TYPE	N. OF STAGES	DNM	DIMENSIONS (mm)		PUMP WEIGHT kg	ELECTRIC PUMP WEIGHT kg
			L1	L		
			4GS056M-4OS	4		
4GS076M-4OS	5	Rp 1 1/4	266	644	2,7	12
4GS116M-4OS	8	Rp 1 1/4	330	743	3,3	14,5
4GS156M-4OS	10	Rp 1 1/4	374	822	3,8	16,5
4GS226M-4OS	15	Rp 1 1/4	481	979	4,8	20
4GS056T-4OS	4	Rp 1 1/4	244	597	2,5	10
4GS076T-4OS	5	Rp 1 1/4	266	619	2,7	11
4GS116T-4OS	8	Rp 1 1/4	330	708	3,3	12,5
4GS156T-4OS	10	Rp 1 1/4	374	787	3,8	15
4GS226T-4OS	15	Rp 1 1/4	481	929	4,8	17,5
4GS306T-4OS	19	Rp 1 1/4	568	1016	5,7	19,5
4GS406T-4OS	27	Rp 1 1/4	770	1338	7,6	25,5

4gs-4os-2p60-en\_a\_td

## 4GS..L4C SERIES DIMENSIONS AND WEIGHTS

ELECTRIC PUMP TYPE	N. OF STAGES	DNM	DIMENSIONS (mm)		PUMP WEIGHT kg	ELECTRIC PUMP WEIGHT kg
			L1	L		
			4GS056M-L4C	4		
4GS076M-L4C	5	Rp 1 1/4	266	595	2,7	14,5
4GS116M-L4C	8	Rp 1 1/4	330	719	3,3	17,5
4GS156M-L4C	10	Rp 1 1/4	374	783	3,8	19
4GS226M-L4C	15	Rp 1 1/4	481	930	4,8	23
4GS056T-L4C	4	Rp 1 1/4	244	508	2,5	11,5
4GS076T-L4C	5	Rp 1 1/4	266	550	2,7	12,5
4GS116T-L4C	8	Rp 1 1/4	330	674	3,3	15
4GS156T-L4C	10	Rp 1 1/4	374	763	3,8	18
4GS226T-L4C	15	Rp 1 1/4	481	890	4,8	20
4GS306T-L4C	19	Rp 1 1/4	568	1110	5,7	27
4GS406T-L4C	27	Rp 1 1/4	770	1384	7,6	31,5

4gs-l4c-2p60-en\_a\_td

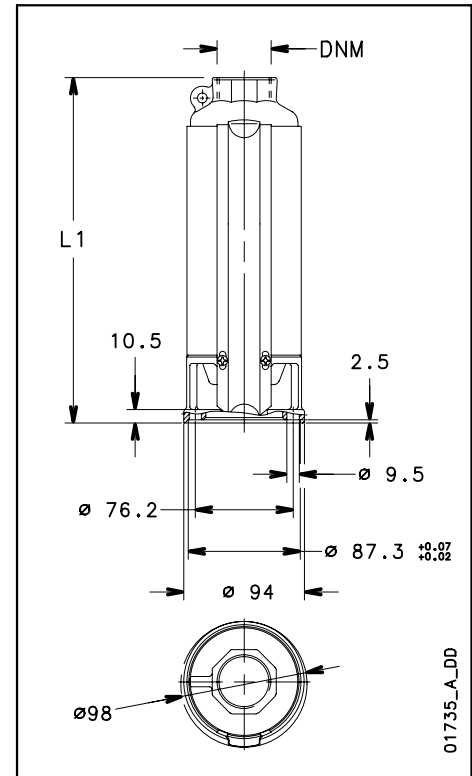

01735\_A\_DD

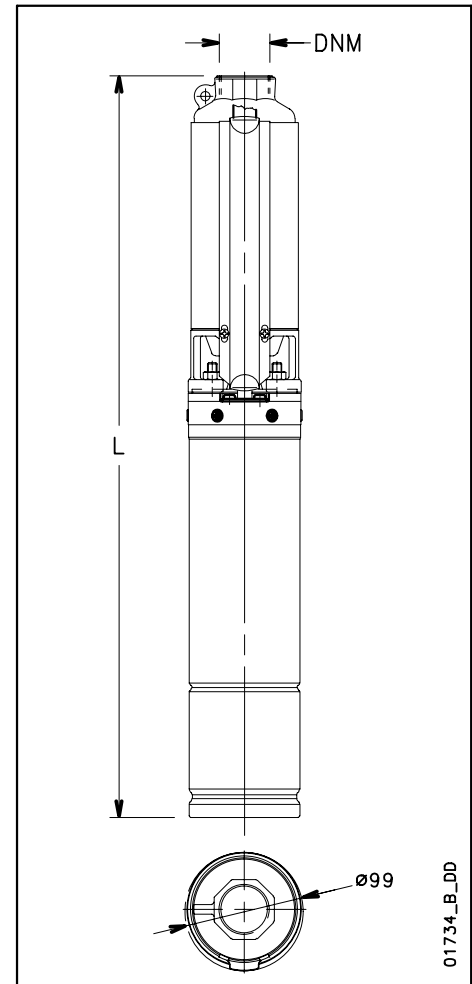

01734\_B\_DD

**4GS SERIES  
OPERATING CHARACTERISTICS AT 60 Hz**

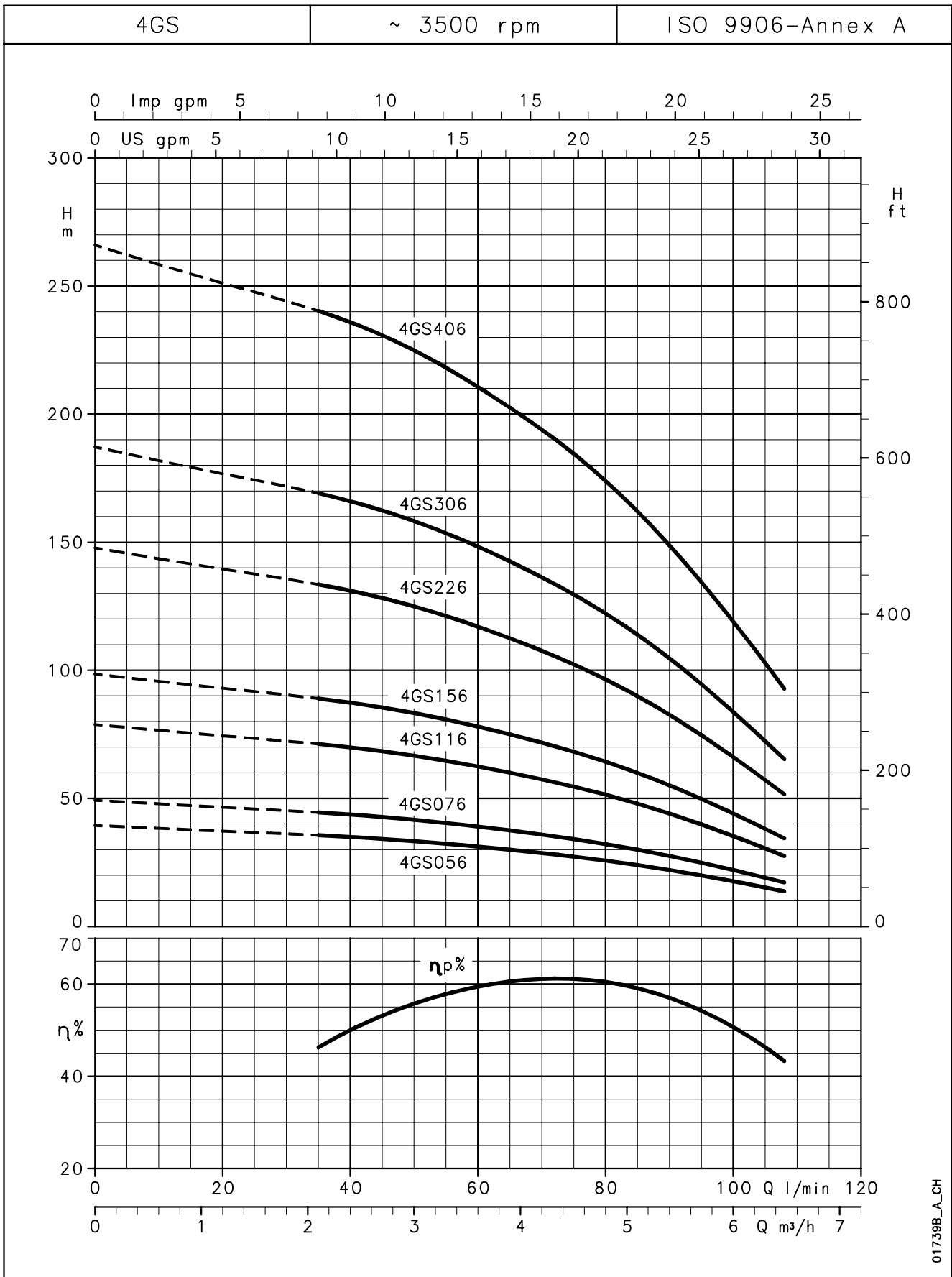

01739B\_A\_CH

These performances are valid for liquids with density  $\rho = 1.0 \text{ Kg/dm}^3$  and kinematic viscosity  $\nu = 1 \text{ mm}^2/\text{sec}$ .

## 6GS SERIES OPERATING CHARACTERISTICS AT 60 Hz

PUMP TYPE	N. OF STAGES	MOTOR POWER		Q = DELIVERY						
				l/min	0	60	80	120	140	160
				m <sup>3</sup> /h	0	3,6	4,8	7,2	8,4	9,6
				H = TOTAL HEAD METRES COLUMN OF WATER						
6GS076	4	0,75	1	36	30,2	28	23	18	13,6	
6GS116	6	1,1	1,5	54	45,3	42	34	28	20,4	
6GS156	8	1,5	2	72	60,4	56	45	37	27,2	
6GS226	12	2,2	3	107	90,6	85	67	55	40,8	
6GS306	16	3	4	143	121	113	90	74	54,4	
6GS406	21	4	5,5	188	159	148	118	97	71,4	
6GS556	29	5,5	7,5	260	219	205	163	133	98,6	

6gs-2p60-en\_b\_th

## 6GS..4OS SERIES DIMENSIONS AND WEIGHTS

ELECTRIC PUMP TYPE *	N. OF STAGES	DNM	DIMENSIONS (mm)		PUMP WEIGHT kg	ELECTRIC PUMP WEIGHT kg
			L1	L		
6GS076M-4OS	4	Rp 1 1/4	297	675	3,1	12,5
6GS116M-4OS	6	Rp 1 1/4	359	772	3,8	15
6GS156M-4OS	8	Rp 1 1/4	421	869	4,4	17
6GS226M-4OS	12	Rp 1 1/4	545	1043	5,7	20,5
6GS076T-4OS	4	Rp 1 1/4	297	650	3,1	11
6GS116T-4OS	6	Rp 1 1/4	359	737	3,8	13
6GS156T-4OS	8	Rp 1 1/4	421	834	4,4	15,5
6GS226T-4OS	12	Rp 1 1/4	545	993	5,7	18,5
6GS306T-4OS	16	Rp 1 1/4	707	1155	7,5	21,5
6GS406T-4OS	21	Rp 1 1/4	862	1430	9,1	27
6GS556T-4OS	29	Rp 1 1/4	1127	1755	11,8	33

6gs-4os-2p60-en\_a\_td

## 6GS..L4C SERIES DIMENSIONS AND WEIGHTS

ELECTRIC PUMP TYPE *	N. OF STAGES	DNM	DIMENSIONS (mm)		PUMP WEIGHT kg	ELECTRIC PUMP WEIGHT kg
			L1	L		
6GS076M-L4C	4	Rp 1 1/4	297	626	3,1	15
6GS116M-L4C	6	Rp 1 1/4	359	748	3,8	18
6GS156M-L4C	8	Rp 1 1/4	421	830	4,4	20
6GS226M-L4C	12	Rp 1 1/4	545	994	5,7	23,5
6GS076T-L4C	4	Rp 1 1/4	297	581	3,1	13
6GS116T-L4C	6	Rp 1 1/4	359	703	3,8	15,5
6GS156T-L4C	8	Rp 1 1/4	421	810	4,4	18,5
6GS226T-L4C	12	Rp 1 1/4	545	954	5,7	20,5
6GS306T-L4C	16	Rp 1 1/4	707	1249	7,5	28,5
6GS406T-L4C	21	Rp 1 1/4	862	1474	9,1	33
6GS556T-L4C	29	Rp 1 1/4	1127	1809	11,8	39

\* Electric pumps exceeding 1500 mm in length are supplied uncoupled.  
Motor and pump are packed separately.

6gs-l4c-2p60-en\_a\_td

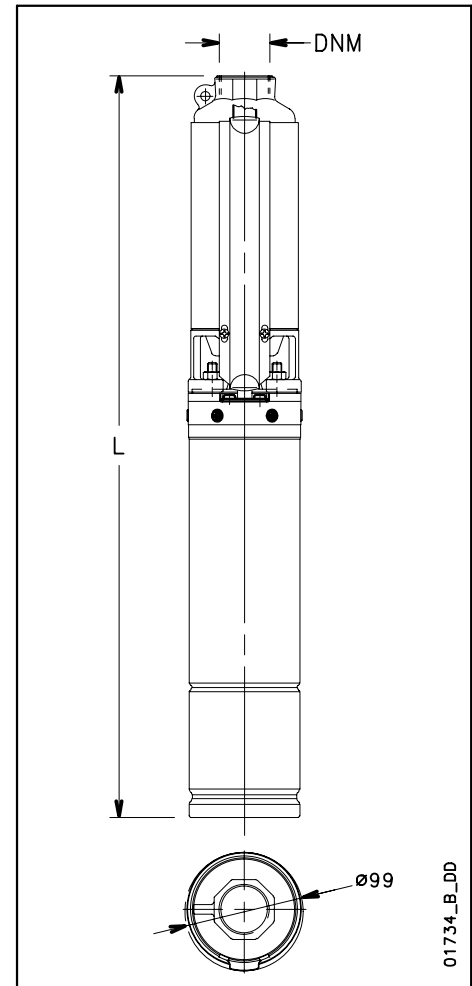
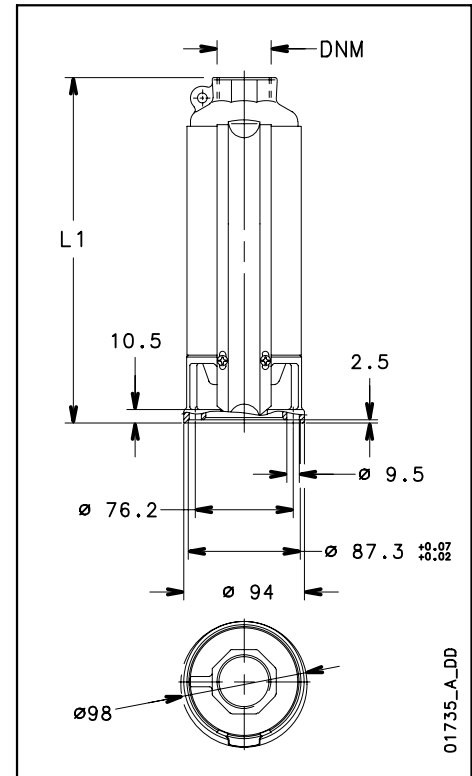



**6GS SERIES  
OPERATING CHARACTERISTICS AT 60 Hz**

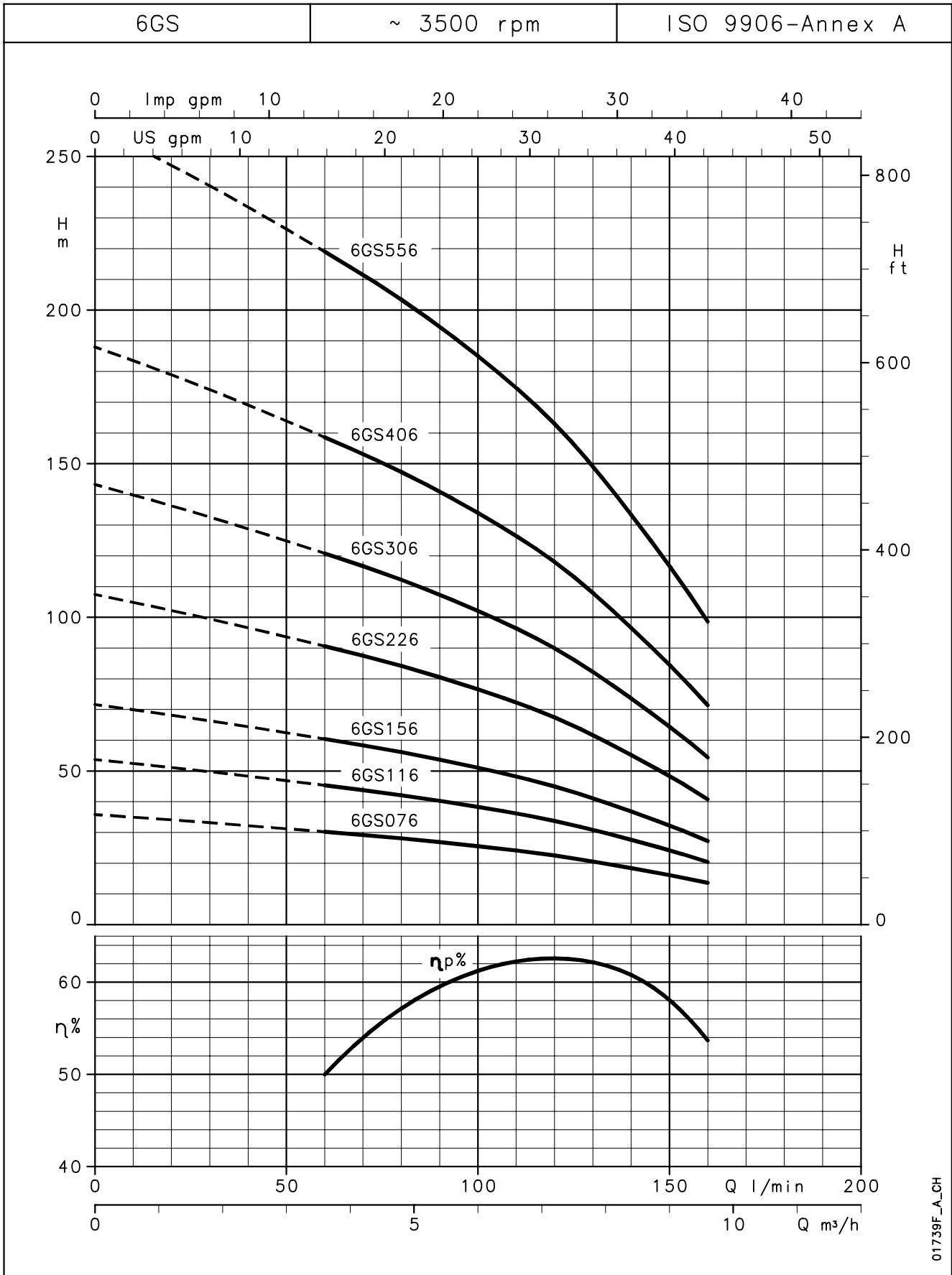

01739F\_A\_CH

These performances are valid for liquids with density  $\rho = 1.0 \text{ Kg/dm}^3$  and kinematic viscosity  $\nu = 1 \text{ mm}^2/\text{sec}$ .

## 8GS SERIES OPERATING CHARACTERISTICS AT 60 Hz

PUMP TYPE	N. OF STAGES	MOTOR POWER		Q = DELIVERY						
				H = TOTAL HEAD METRES COLUMN OF WATER						
				l/min	0	83	120	160	200	225
				m <sup>3</sup> /h	0	5	7,2	9,6	12	13,5
		kW	HP							
8GS116	3	1,1	2	28	25,5	24	21	17	12	
8GS156	5	1,5	2	47	42,5	40	35	28	21	
8GS226	7	2,2	3	66	59	56	50	39	29	
8GS306	10	3	4	94	85	80	71	55	41	
8GS406	13	4	5,5	122	110	104	92	72	53	
8GS556	17	5,5	7,5	160	144	136	120	94	70	
8GS756	23	7,5	10	216	196	184	163	127	92	

8gs-2p60-en\_b\_th

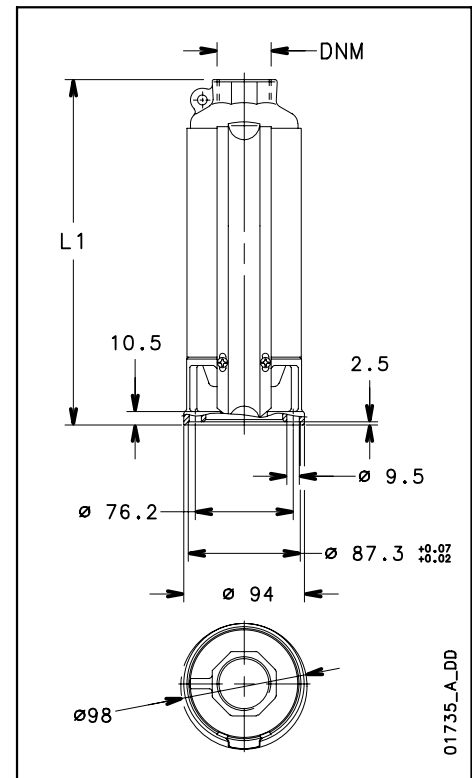

## 8GS..4OS SERIES DIMENSIONS AND WEIGHTS

ELECTRIC PUMP TYPE *	N. OF STAGES	DNM	DIMENSIONS (mm)		PUMP WEIGHT kg	ELECTRIC PUMP WEIGHT kg
			L1	L		
8GS116M-4OS	3	Rp 2	268	681	3	14
8GS156M-4OS	5	Rp 2	330	778	3,5	16
8GS226M-4OS	7	Rp 2	392	890	4,2	19
8GS116T-4OS	3	Rp 2	268	646	3	12
8GS156T-4OS	5	Rp 2	330	743	3,5	15
8GS226T-4OS	7	Rp 2	392	840	4,2	17
8GS306T-4OS	10	Rp 2	485	933	5,1	19
8GS406T-4OS	13	Rp 2	578	1146	6	23,5
8GS556T-4OS	17	Rp 2	740	1368	7,8	29
8GS756T-4OS	23	Rp 2	926	1760	9,6	38,5

8gs-4os-2p60-en\_a\_td

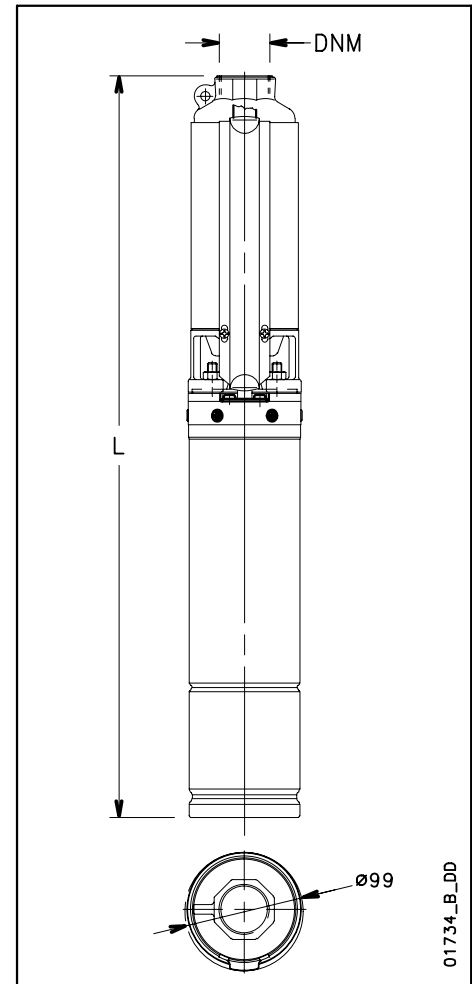

## 8GS..L4C SERIES DIMENSIONS AND WEIGHTS

ELECTRIC PUMP TYPE *	N. OF STAGES	DNM	DIMENSIONS (mm)		PUMP WEIGHT kg	ELECTRIC PUMP WEIGHT kg
			L1	L		
8GS116M-L4C	3	Rp 2	268	657	3	17
8GS156M-L4C	5	Rp 2	330	739	3,5	19
8GS226M-L4C	7	Rp 2	392	841	4,2	22
8GS116T-L4C	3	Rp 2	268	612	3	15
8GS156T-L4C	5	Rp 2	330	719	3,5	17,5
8GS226T-L4C	7	Rp 2	392	801	4,2	19
8GS306T-L4C	10	Rp 2	485	1027	5,1	26,5
8GS406T-L4C	13	Rp 2	578	1190	6	30
8GS556T-L4C	17	Rp 2	740	1422	7,8	35
8GS756T-L4C	23	Rp 2	926	1688	9,6	40

\* Electric pumps exceeding 1500 mm in length are supplied uncoupled.  
Motor and pump are packed separately.

8gs-l4c-2p60-en\_a\_td

**8GS SERIES  
OPERATING CHARACTERISTICS AT 60 Hz**

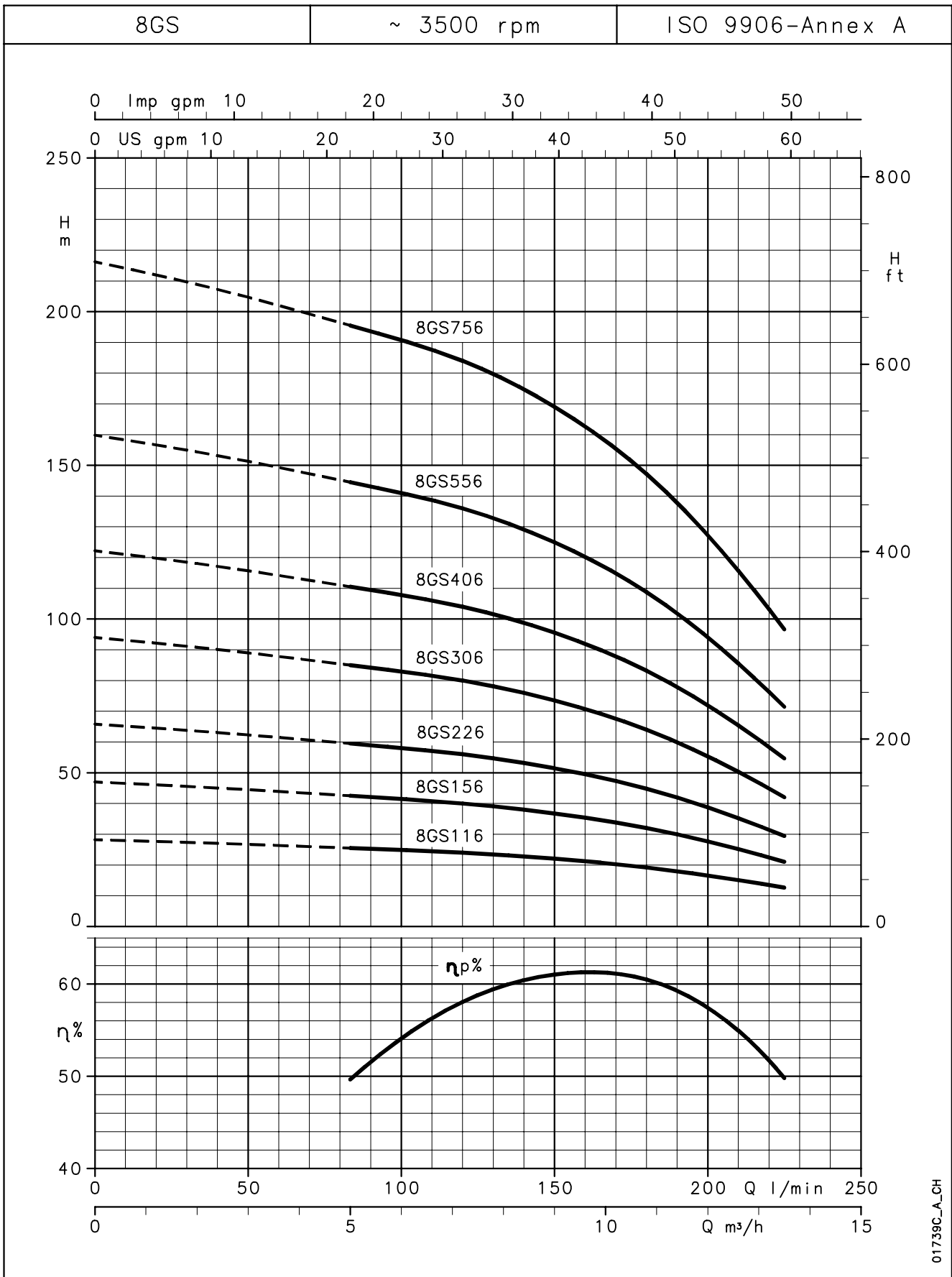

01739C\_A\_CH

These performances are valid for liquids with density  $\rho = 1.0 \text{ Kg/dm}^3$  and kinematic viscosity  $\nu = 1 \text{ mm}^2/\text{sec}$ .

## 12GS SERIES OPERATING CHARACTERISTICS AT 60 Hz

PUMP TYPE	N. OF STAGES	MOTOR POWER		Q = DELIVERY						
				l/min	0	100	150	175	200	250
				m <sup>3</sup> /h	0	6	9	10,5	12	15
				H = TOTAL HEAD METRES COLUMN OF WATER						
12GS15	7	1,5	2	43,9	37,3	31	28	24	14,6	
12GS22	11	2,2	3	69	58,4	49	43	37	22,5	
12GS30	15	3	4	94	79,4	67	59	50	30	
12GS40	20	4	5,5	128,6	109,9	94	84	73	46	
12GS55	27	5,5	7,5	173,6	148,3	127	113	98	62	
12GS75	35	7,5	10	221,8	190,2	163	146	126	80	

12gs-2p50-en\_b\_th

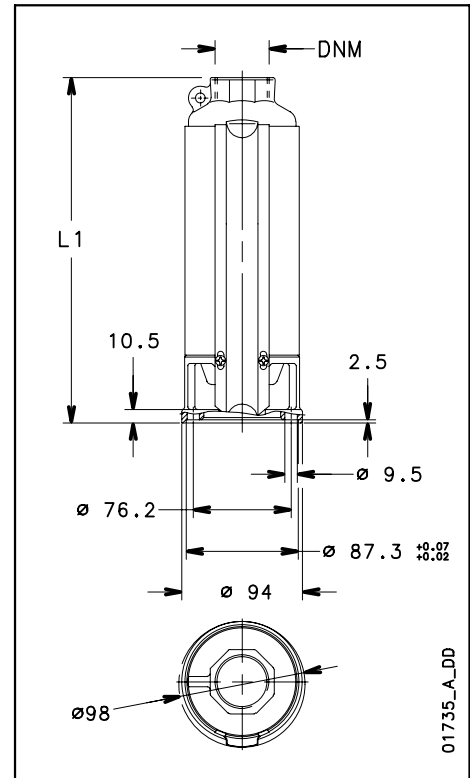

01735\_A\_DD

## 12GS..4OS SERIES DIMENSIONS AND WEIGHTS

ELECTRIC PUMP TYPE *	N. OF STAGES	DNM	DIMENSIONS (mm)		PUMP WEIGHT kg	ELECTRIC PUMP WEIGHT kg
			L1	L		
12GS156M-4OS	4	Rp 2	383	831	4,4	17
12GS226M-4OS	6	Rp 2	487	985	5,4	20,5
12GS156T-4OS	4	Rp 2	383	796	4,4	15,5
12GS226T-4OS	6	Rp 2	487	935	5,4	18
12GS306T-4OS	8	Rp 2	591	1039	6,4	20
12GS406T-4OS	10	Rp 2	733	1301	7,4	25
12GS556T-4OS	14	Rp 2	940	1568	9,5	30,5
12GS756T-4OS	19	Rp 2	1200	2034	12,1	41

12gs-4os-2p60-en\_a\_td

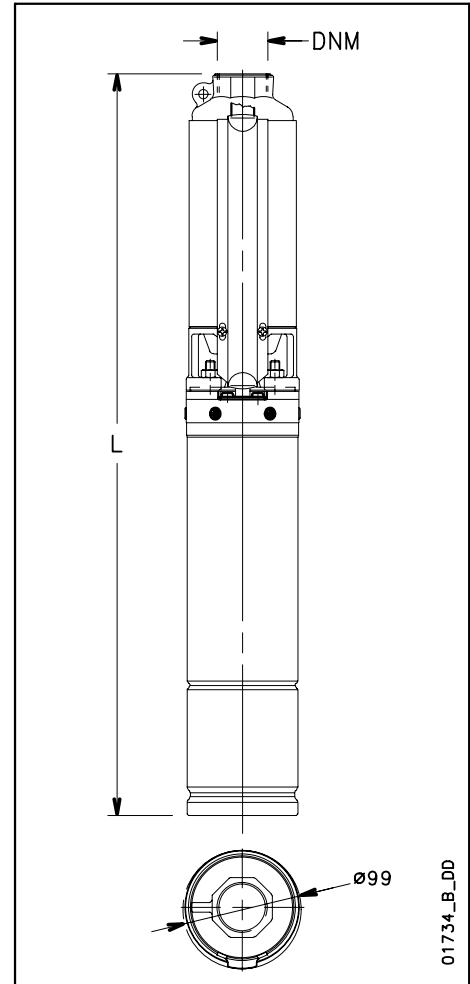

01734\_B\_DD

## 12GS..L4C SERIES DIMENSIONS AND WEIGHTS

ELECTRIC PUMP TYPE *	N. OF STAGES	DNM	DIMENSIONS (mm)		PUMP WEIGHT kg	ELECTRIC PUMP WEIGHT kg
			L1	L		
12GS156M-L4C	4	Rp 2	383	792	4,4	20
12GS226M-L4C	6	Rp 2	487	936	5,4	23,5
12GS156T-L4C	4	Rp 2	383	772	4,4	18,5
12GS226T-L4C	6	Rp 2	487	896	5,4	20,5
12GS306T-L4C	8	Rp 2	591	1133	6,4	27,5
12GS406T-L4C	10	Rp 2	733	1345	7,4	31,5
12GS556T-L4C	14	Rp 2	940	1622	9,5	36,5
12GS756T-L4C	19	Rp 2	1200	1962	12,1	42,5

\* Electric pumps exceeding 1500 mm in length are supplied uncoupled.  
Motor and pump are packed separately.

12gs-l4c-2p60-en\_a\_td

**12GS SERIES  
OPERATING CHARACTERISTICS AT 60 Hz**

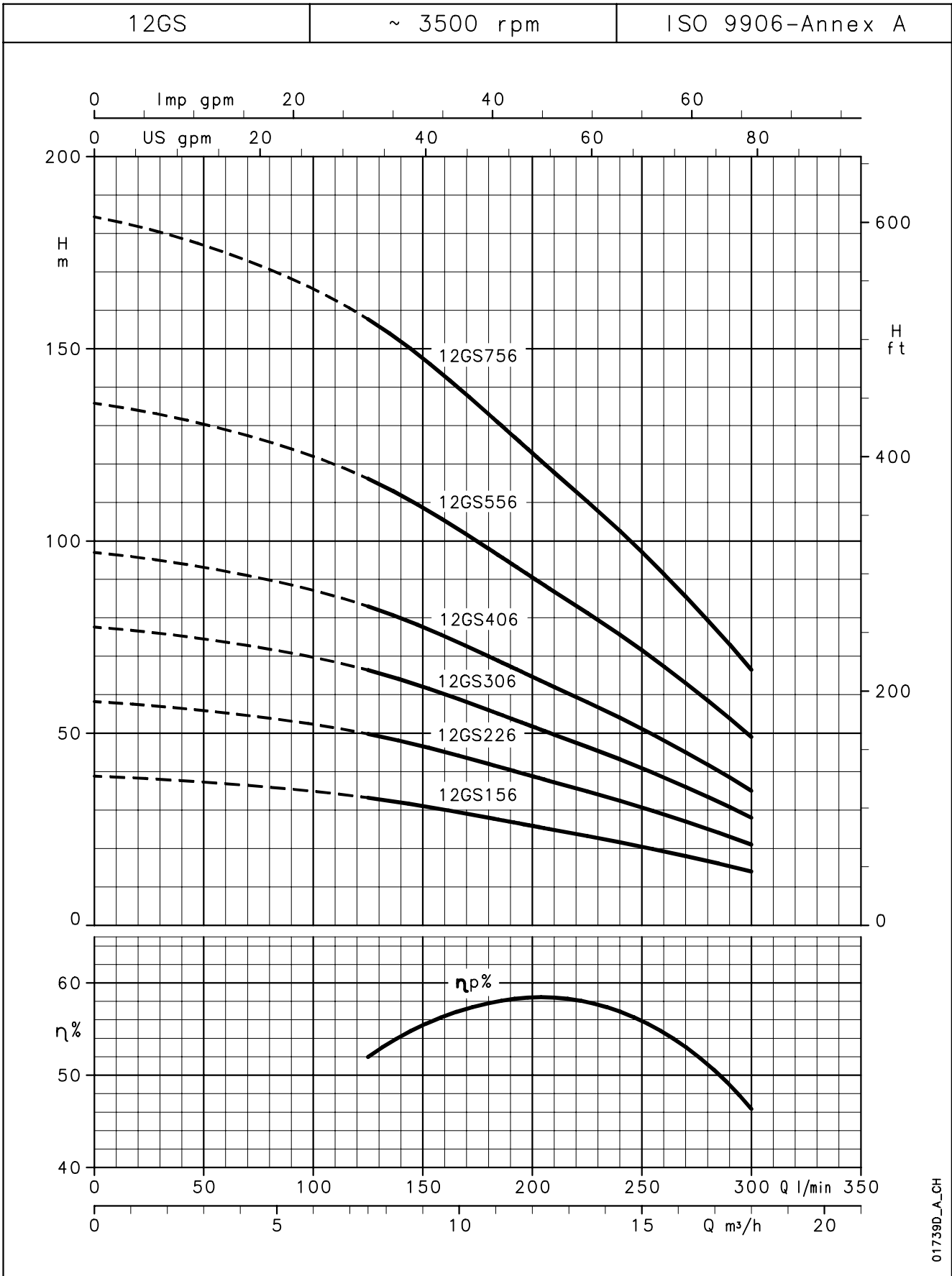

01739D\_A\_CH

These performances are valid for liquids with density  $\rho = 1.0 \text{ Kg/dm}^3$  and kinematic viscosity  $\nu = 1 \text{ mm}^2/\text{sec}$ .

## 16GS SERIES OPERATING CHARACTERISTICS AT 60 Hz

PUMP TYPE	N. OF STAGES	MOTOR POWER		Q = DELIVERY						
				l/min	0	160	200	300	350	450
				m <sup>3</sup> /h	0	9,6	12	18	21	27
				H = TOTAL HEAD METRES COLUMN OF WATER						
16GS226	5	2,2	3	44	37	34	27	23	14	
16GS306	6	3	4	53	44	41	33	28	17	
16GS406	8	4	5,5	71	58	55	44	37	22	
16GS556	11	5,5	7,5	97	80	75	60	51	30	
16GS756	15	7,5	10	133	111	102	82	69	42	

16gs-2p60-en\_b\_th

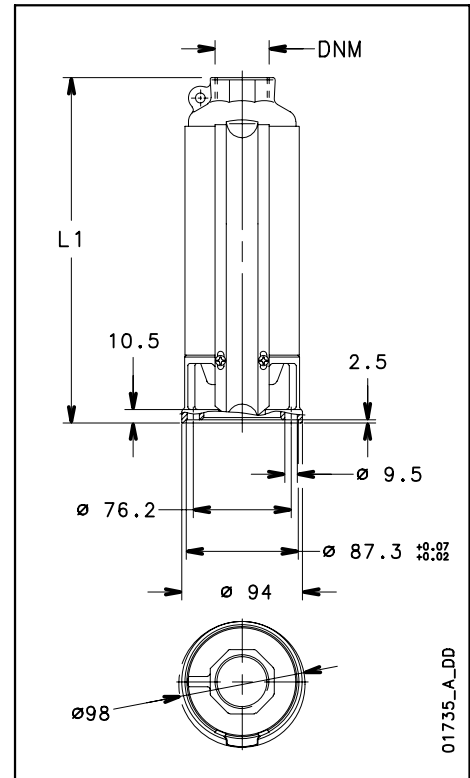

01735\_A\_DD

## 16GS..4OS SERIES DIMENSIONS AND WEIGHTS

ELECTRIC PUMP TYPE *	N. OF STAGES	DNM	DIMENSIONS (mm)		PUMP WEIGHT kg	ELECTRIC PUMP WEIGHT kg
			L1	L		
16GS226M-4OS	5	Rp 2	477	975	5	20
16GS226T-4OS	5	Rp 2	477	925	5	18
16GS306T-4OS	6	Rp 2	545	993	5,6	19,5
16GS406T-4OS	8	Rp 2	681	1249	7	24,5
16GS556T-4OS	11	Rp 2	885	1513	9	30
16GS756T-4OS	15	Rp 2	1156	1990	11,7	40,5

16gs-4os-2p60-en\_a\_td

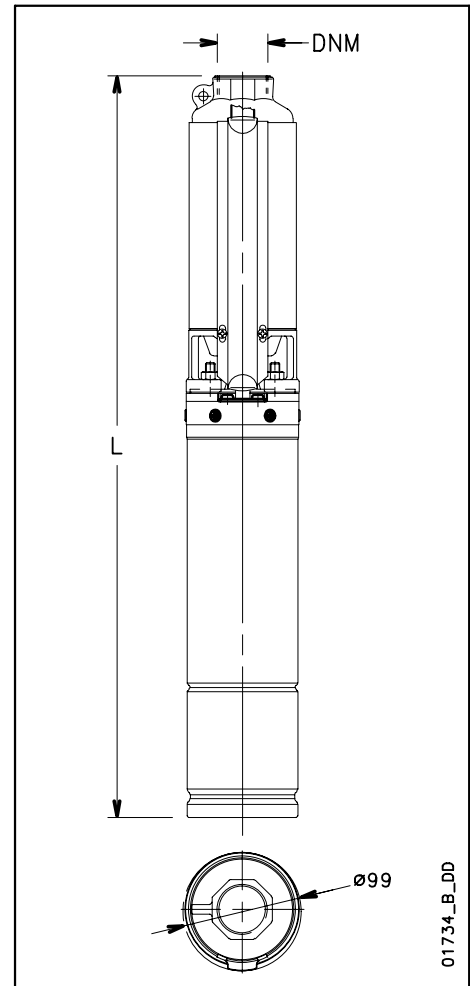

01734\_B\_DD

## 16GS..L4C SERIES DIMENSIONS AND WEIGHTS

ELECTRIC PUMP TYPE *	N. OF STAGES	DNM	DIMENSIONS (mm)		PUMP WEIGHT kg	ELECTRIC PUMP WEIGHT kg
			L1	L		
16GS226M-L4C	5	Rp 2	477	926	5	23
16GS226T-L4C	5	Rp 2	477	886	5	20
16GS306T-L4C	6	Rp 2	545	1087	5,6	27
16GS406T-L4C	8	Rp 2	681	1293	7	31
16GS556T-L4C	11	Rp 2	885	1567	9	36
16GS756T-L4C	15	Rp 2	1156	1918	11,7	42

\* Electric pumps exceeding 1500 mm in length are supplied uncoupled.  
Motor and pump are packed separately.

16gs-l4c-2p60-en\_a\_td

**16GS SERIES  
OPERATING CHARACTERISTICS AT 60 Hz**

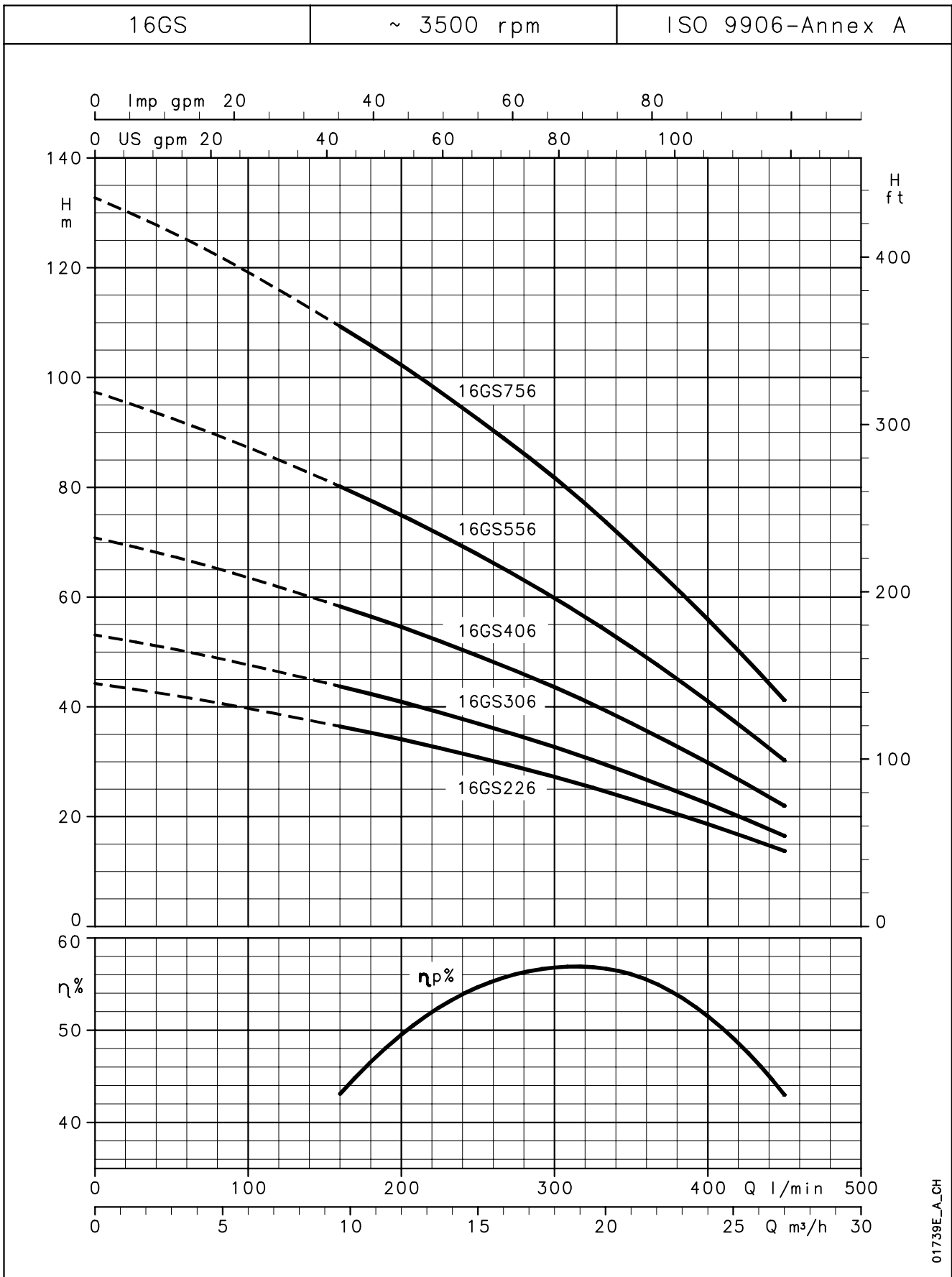

01739E\_A-CH

These performances are valid for liquids with density  $\rho = 1.0 \text{ Kg/dm}^3$  and kinematic viscosity  $\nu = 1 \text{ mm}^2/\text{sec}$ .

# 1GSL - 2GS - 4GS SERIES PUMP SECTION AND LIST OF MAIN COMPONENTS

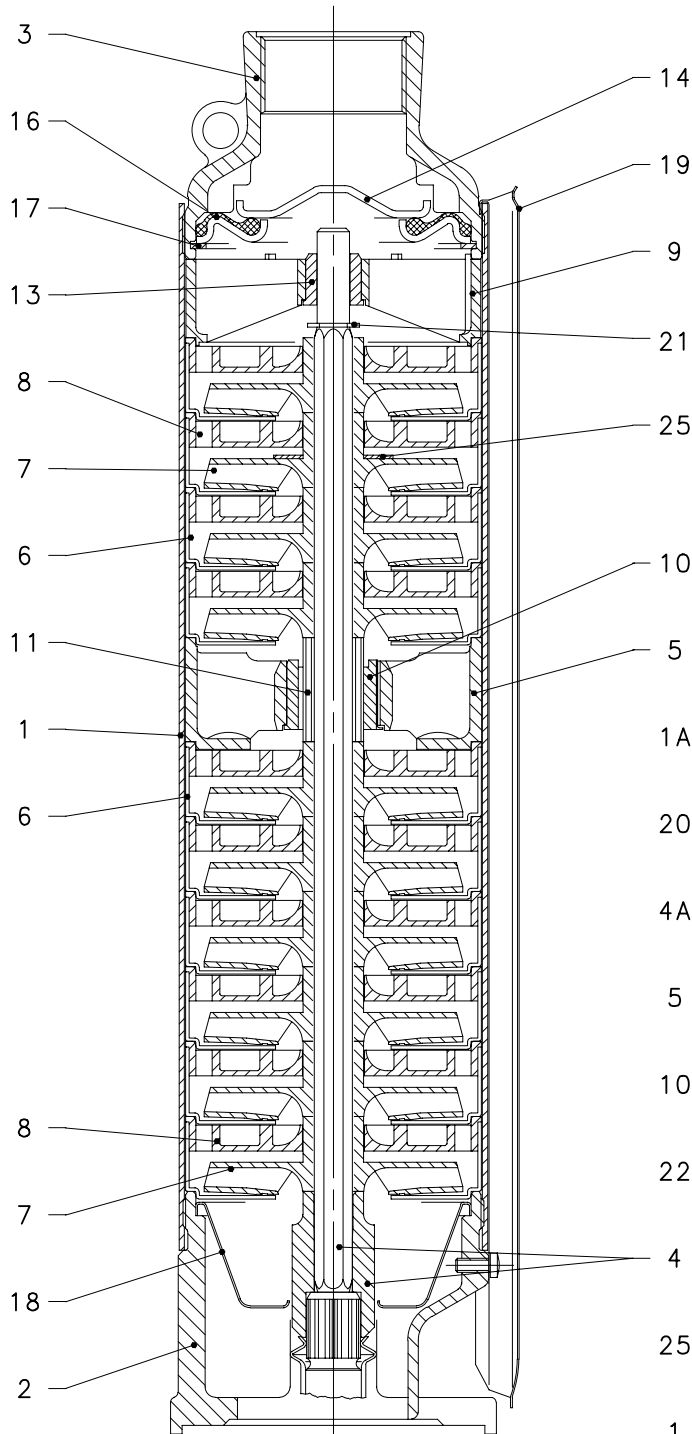

REF.N.	DESCRIPTION
1	Sleeve
1A	Upper sleeve
2	Lower support
3	Delivery port
4	Shaft with coupling
4A	Upper shaft with coupling
5	Intermediate support
6	Stage housing
7	Impeller
8	Diffuser
9	Upper support
10	Intermediate bush bearing
11	Shaft sleeve
13	Upper bush bearing
14	Valve cap
16	Valve support with gasket
17	Valve locking ring
18	Filter
19	Cable guard
20	Impeller shim
21	Upper split ring
22	Intermediate split ring
25	Washer

1gsl-2gs-4gs-2p60-en\_a\_tp

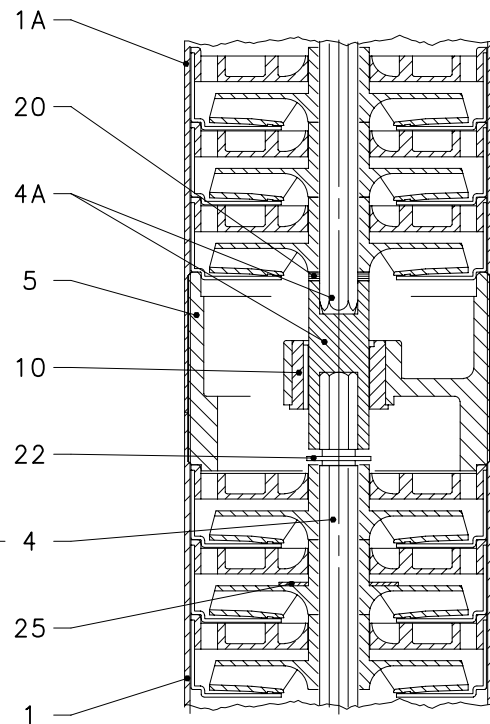

01731A\_B\_DS



**6GS - 8GS SERIES  
PUMP SECTION AND LIST OF MAIN COMPONENTS**

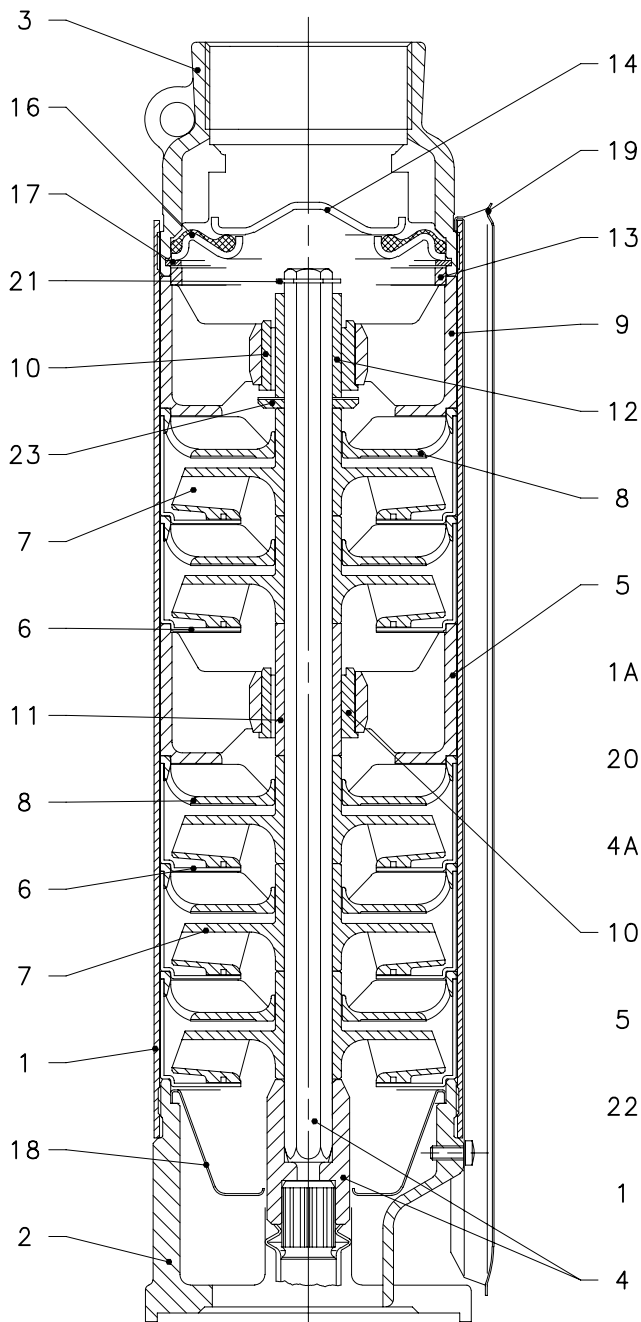

REF.N.	DESCRIPTION
1	Sleeve
1A	Upper sleeve
2	Lower support
3	Delivery port
4	Shaft with coupling
4A	Upper shaft with coupling
5	Intermediate support
6	Stage housing
7	Impeller
8	Diffuser
9	Upper support
10	Bush bearing
11	Shaft sleeve
12	Upper spacer
13	Adapter ring
14	Valve cap
16	Valve support with gasket
17	Valve locking ring
18	Filter
19	Cable guard
20	Impeller shim
21	Upper split ring
22	Intermediate split ring
23	Thrust bearing
24	Washer

6gs-8gs-2p60-en\_a\_tp

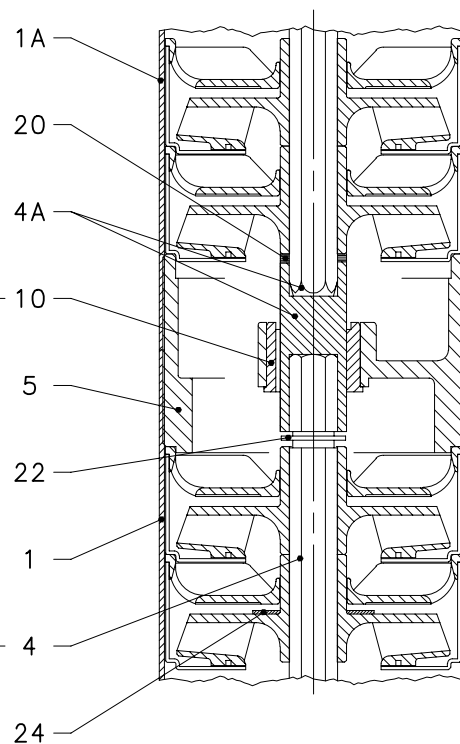

01732\_B\_DS

**12GS SERIES  
PUMP SECTION AND LIST OF MAIN COMPONENTS**

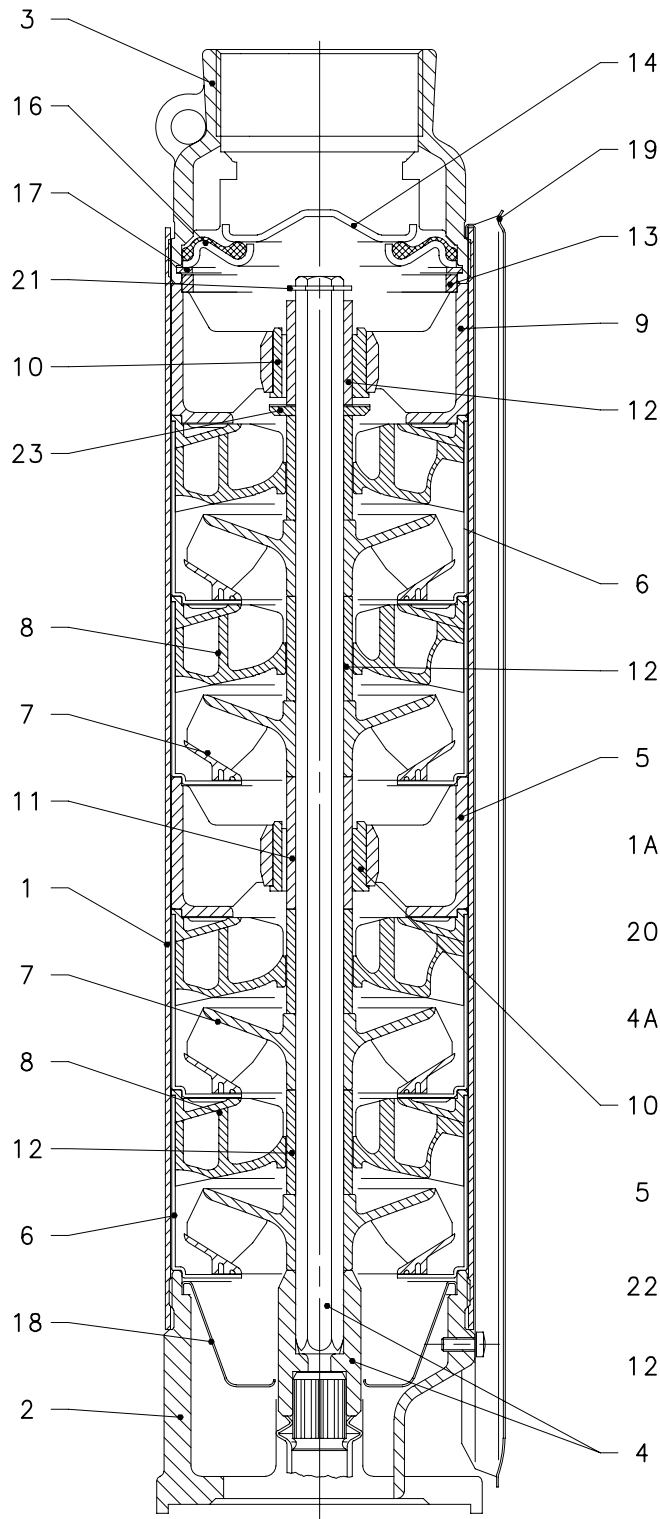

REF.N.	DESCRIPTION
1	Sleeve
1A	Upper sleeve
2	Lower support
3	Delivery port
4	Shaft with coupling
4A	Upper shaft with coupling
5	Intermediate support
6	Stage housing
7	Impeller
8	Diffuser
9	Upper support
10	Bush bearing
11	Shaft sleeve
12	Spacer
13	Adapter ring
14	Valve cap
16	Valve support with gasket
17	Valve locking ring
18	Filter
19	Cable guard
20	Impeller shim
21	Upper split ring
22	Intermediate split ring
23	Thrust bearing

12gs-2p60-en\_a\_tp

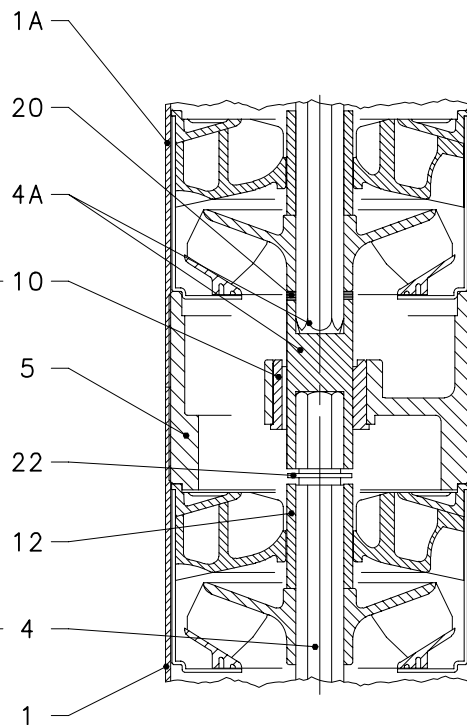

01732A\_B\_DS

**16GS SERIES  
PUMP SECTION AND LIST OF MAIN COMPONENTS**

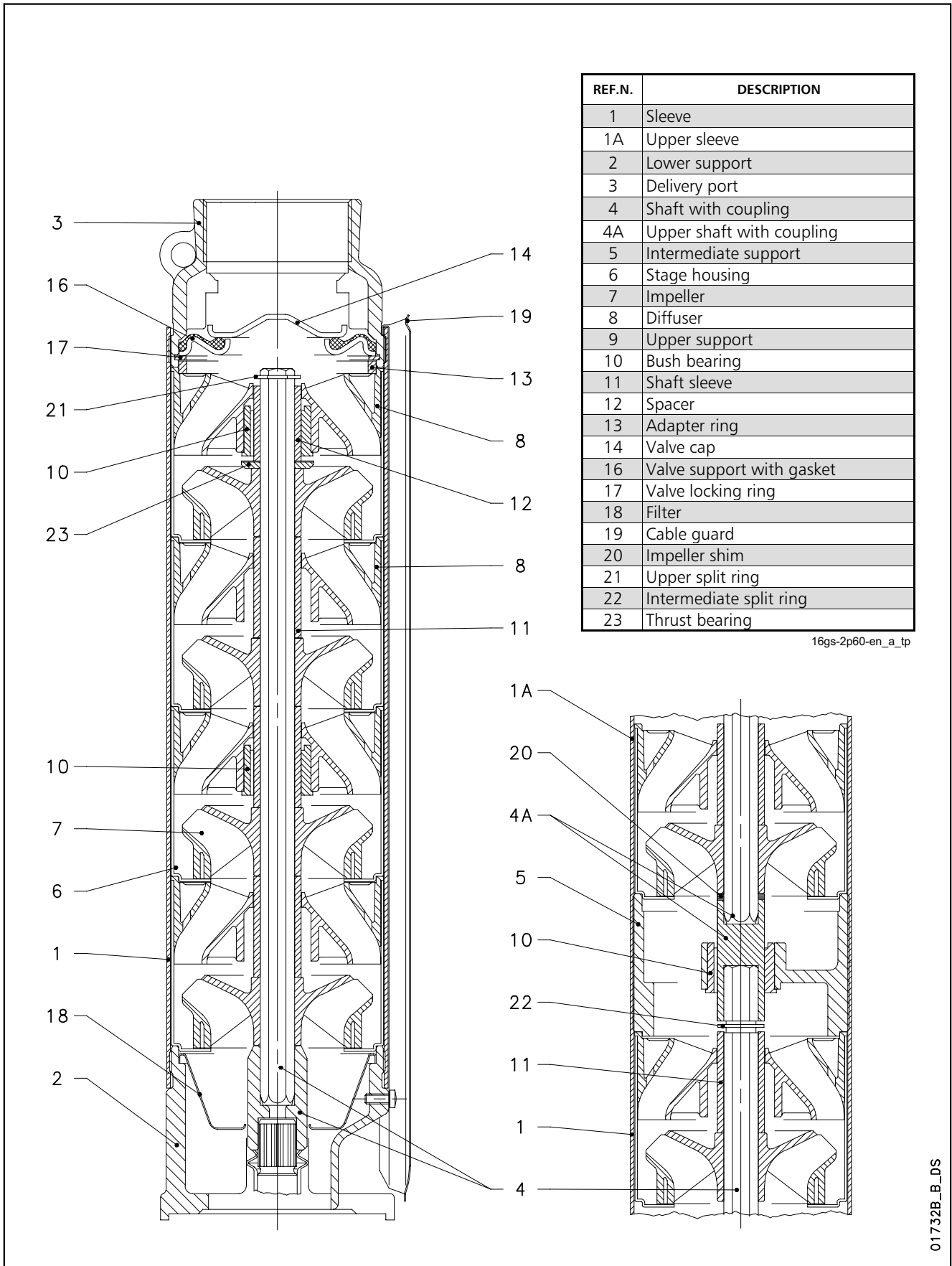



## 4" Submersible motors

Submersible liquid-cooled motors. The choice of component materials ensures optimum operating performances, superior quality, reliability and ease of installation.

### 4OS Series 60 Hz



#### SPECIFICATIONS

- **Stainless steel** outer sleeve.
- Shaft extension and coupling dimensions to **NEMA** standards.
- **Rewindable stator.**
- Class **F insulation.**
- Protection class: **IP68.**
- **Internal fluid** according to standards for oils in contact with foodstuffs (F.D.A. - FOOD AND DRUG ADMINISTRATION).
- Compensating bellows for internal liquid expansion.
- Axial load supported by angular bearings.
- **Mechanical seal** protected by sand guard.
- Maximum **immersion depth:** 150 m.
- Maximum **number of starts per hour** at regular intervals: 30 for direct start; 20 for impedance start.
- Maximum supply **voltage variations** allowed : 220V -6%; 230V +6%. 380V ±10%.
- Maximum water **temperature** : 35°C. Max. temperature applies to motors working in a installation capable of delivering a flow of water around the motor jacket of at least 0,08 m/s.
- Water **pH:** 4÷8.
- **Axial thrust:** 3000 N from 0,37 to 2,2 kW; 6500 N from 3 to 7,5 kW.
- **Extractable supply cable** fitted with watertight connector.
- **Versions:**
  - Single-phase: 0,37 to 2,2 kW 220-230 V, 60 Hz
  - Three-phase: 0,37 to 7,5 kW 220-230 V, 60 Hz 0,37 to 7,5 kW 380 V, 60 Hz.
- Horizontal operation up to 2,2 kW.
- Inverter applications.

#### OPTIONAL FEATURES

- Special voltages.

**Rewindable stator**

**Liquid suitable for use with foodstuffs (complies with FDA)**

**High starting torque**

**Power supply cable with extractable connector**

## 40S MOTOR SERIES MOTOR CROSS SECTION AND TABLE OF MATERIALS

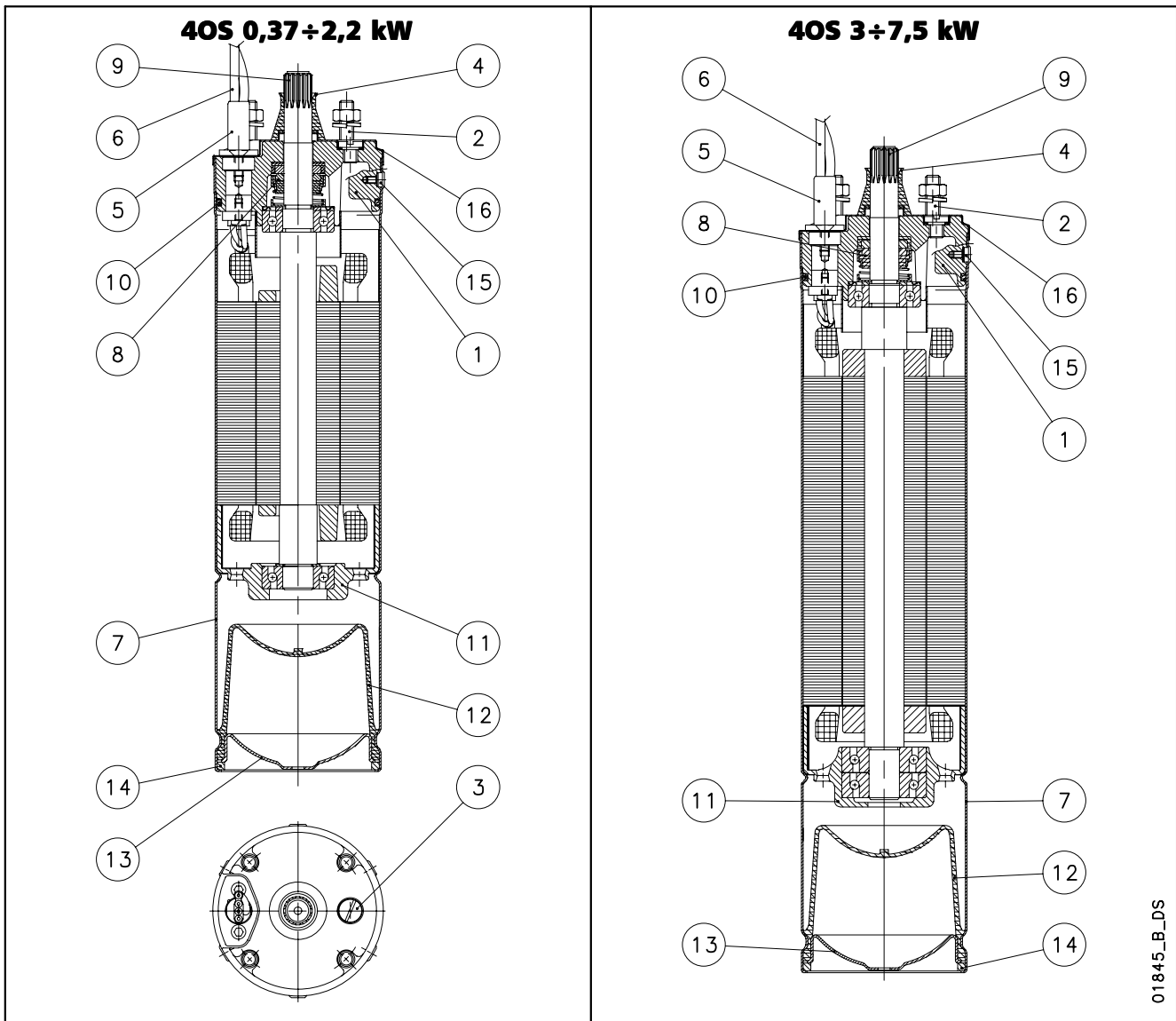

01845\_B\_DS

REF. N.	PART	MATERIAL	DESIGNATION	
			EUROPE	USA
1	Head	Cast iron	UNI EN 5007 G20	ASTM A159-70-G3500
2	Studs	Stainless steel	EN 10088-3-X5CrNi18-10 (1.4301)	AISI 304
3	Filling screw	Brass	EN12165-CuZn40Pb2 (CW617N)	
4	Sand guard	NBR		
5	Connector sleeve	Stainless steel	EN 10088-1-X5CrNi18-10 (1.4301)	AISI 304
6	Cable	Epdm		
7	Outer sleeve	Stainless steel	EN 10088-1-X5CrNi18-10 (1.4301)	AISI 304
8	Mechanical seal	Carbon / Ceramic		
9	Shaft end for P ≤ 2.2 kW	Stainless steel	EN 10088-3-X8CrNiS18-9 (1.4305)	AISI 303
	Shaft end for 3 ≤ P ≤ 7.5 kW	Stainless steel	EN 10088-1-X2CrNiMoN22-5-3 (1.4462)	ASTM A 182: F51
10	Elastomers	NBR		
11	Lower bracket	Cast iron	UNI EN 5007 G20	ASTM A159-70-G3500
12	Compensating diaphragm	NBR		
13	Lower protection	Stainless steel	EN 10088-1-X5CrNi18-10 (1.4301)	AISI 304
14	Snap ring	Stainless steel	EN 10088-1-X5CrNi18-10 (1.4301)	AISI 304
15	Screws, nuts, washers	Stainless steel	EN 10088-3-X5CrNi18-10 (1.4301)	AISI 304
16	Upper cover	Stainless steel	EN 10088-1-X5CrNi18-10 (1.4301)	AISI 304
	Cooling liquid	Non toxic oil		

## 4OS MOTOR SERIES IDENTIFICATION CODE

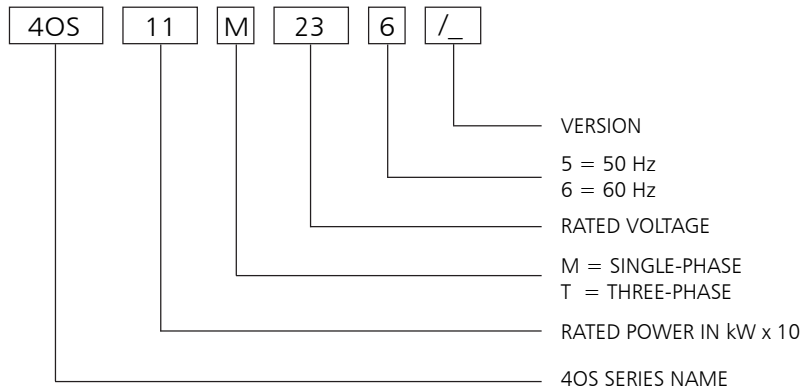

EXAMPLE : 4OS11M236/C

4OS MOTOR :  
RATED POWER 1,1 kW; SINGLE-PHASE;  
RATED VOLTAGE 230 V; 60 Hz; /C VERSION.

## RATING PLATE

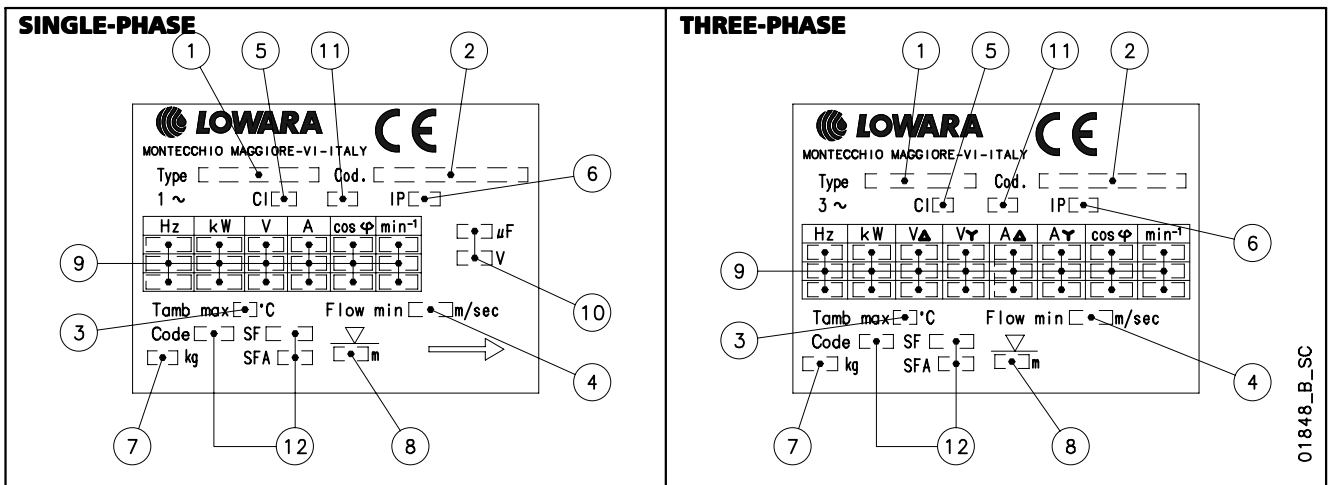

## LEGEND

- |   |  |
|---|--|
| <ul style="list-style-type: none"> <li>1 - Motor type</li> <li>2 - Code</li> <li>3 - Maximum water temperature</li> <li>4 - Minimum water velocity</li> <li>5 - Insulation class</li> <li>6 - Protection class</li> </ul> | <ul style="list-style-type: none"> <li>7 - Weight</li> <li>8 - Maximum immersion depth</li> <li>9 - Operating characteristics</li> <li>10 - Capacitor type</li> <li>11 - Service type</li> <li>12 - Characteristics at service factor</li> </ul> |
|---|--|

## 4OS MOTOR SERIES DIMENSIONS AND WEIGHTS AT 60 Hz

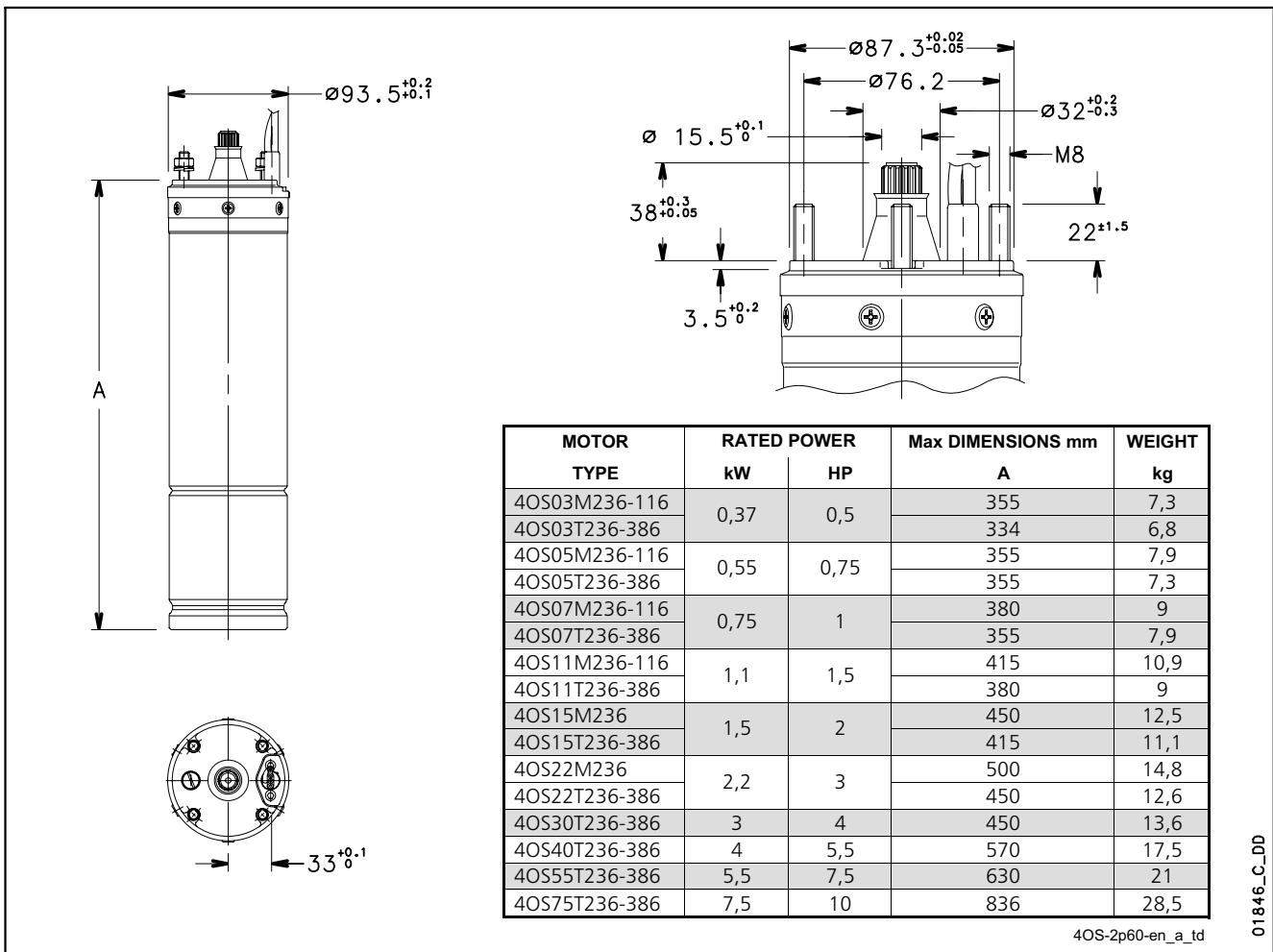

4OS-2p60-en\_a\_td

## SINGLE-PHASE OPERATING CHARACTERISTICS AT 60 Hz

MOTOR TYPE	RATED POWER		RATED VOLTAGE	CAPACITOR	OPERATING CHARACTERISTICS AT RATED POWER				DIRECT ON-LINE STARTING			SERVICE FACTOR	SERVICE FACTOR AMPS	MAX WATER TEMP.	CABLE TYPE		
	kW	HP			V	$\mu$ F	V	A	rpm	$\eta$	cos $\phi$				Is/In	Ts/Tn	Tmax/Tn
4OS03M236	0,37	0,5	220	20	450	3,40	3495	49,7	0,99	4,00	1,23	2,98	1,6	4,50	35	4x1.5	1,75
			230			3,45	3500	47,4	0,98	4,13	1,35	3,26		4,42			
4OS05M236	0,55	0,75	220	25	450	4,66	3445	54,3	0,99	3,26	0,84	2,26	1,5	6,23	35	4x1.5	1,75
			230			4,73	3460	52,2	0,97	3,36	0,92	2,47		6,00			
4OS07M236	0,75	1	220	35	450	5,87	3460	59,8	0,97	3,85	0,74	2,47	1,4	7,41	35	4x1.5	1,75
			230			6,09	3470	56,9	0,94	3,88	0,82	2,72		7,36			
4OS11M236	1,1	1,5	220	40	450	7,61	3450	66,2	0,99	3,64	0,79	2,27	1,3	9,34	35	4x1.5	1,75
			230			7,48	3460	64,4	0,99	3,87	0,87	2,49		9,05			
4OS15M236	1,5	2	220	50	450	10,1	3435	67,8	0,99	3,90	0,63	2,26	1,25	12,2	35	4x1.5	1,75
			230			10,1	3445	66,1	0,97	4,08	0,70	2,49		11,9			
4OS22M236	2,2	3	220	50	450	15,2	3405	70,5	0,93	3,14	0,50	1,79	1,15	17,1	35	4x1.5	2,5
			230			15,7	3420	68,2	0,90	3,18	0,55	1,97		17,1			
4OS03M116	0,37	0,5	110	80	250	6,81	3495	49,8	0,99	4,00	1,23	2,97	1,6	9,02	35	4x1.5	1,75
			115			6,91	3500	47,5	0,98	4,22	1,36	3,32		8,86			
4OS05M116	0,55	0,75	110	100	250	9,68	3480	53,4	0,98	3,63	0,63	2,72	1,5	12,3	35	4x1.5	1,75
			115			10,2	3490	49,9	0,94	3,54	0,67	2,98		12,3			
4OS07M116	0,75	1	110	140	250	11,5	3480	60,7	0,98	4,05	0,56	2,94	1,4	14,5	35	4x1.5	1,75
			115			11,9	3490	57,8	0,95	4,06	0,59	3,02		14,3			
4OS11M116	1,1	1,5	110	160	250	20,1	3465	69,1	0,99	4,05	0,46	2,37	1,3	18,1	35	4x1.5	1,75
			115			14,5	3475	67,3	0,98	4,46	0,49	2,57		17,7			

Ts/Tn = ratio between starting torque and nominal torque.

Tmax/Tn = ratio between maximum torque and nominal torque.

4osm-2p60-en\_b\_te



## 40S MOTOR SERIES THREE-PHASE OPERATING CHARACTERISTICS AT 60 Hz

MOTOR TYPE  THREE-PHASE	RATED POWER		RATED VOLTAGE  V	OPERATING CHARACTERISTICS AT RATED POWER				DIRECT ON-LINE STARTING			SERVICE FACTOR  SF	SERVICE FACTOR AMPS  SFA	MAX WATER TEMP.  °C	CABLE TYPE	
	kW	HP		A	rpm	η %	cosφ	Is/In	Ts/Tn	Tmax/Tn				N x A mm <sup>2</sup>	L m
4OS03T236	0,37	0,5	220	2,68	3485	58,5	0,62	6,40	5,71	4,73	1,6	3,17	35	4x1.5	1,75
			230	2,93	3495	56,4	0,56	6,19	6,33	5,25					
4OS05T236	0,55	0,75	220	3,26	3430	62,3	0,71	5,52	4,40	3,22	1,5	4,00	35	4x1.5	1,75
			230	3,45	3450	61,1	0,65	5,48	4,91	3,59					
4OS07T236	0,75	1	220	4,54	3450	66,3	0,66	5,58	4,23	3,27	1,4	5,21	35	4x1.5	1,75
			230	5,01	3465	63,7	0,59	5,32	4,69	3,62					
4OS11T236	1,1	1,5	220	5,66	3425	71,5	0,72	5,45	3,80	2,89	1,3	6,53	35	4x1.5	1,75
			230	6,06	3445	70,1	0,65	5,37	4,24	3,22					
4OS15T236	1,5	2	220	7,45	3430	74,4	0,71	5,73	3,64	3,01	1,25	8,40	35	4x1.5	1,75
			230	7,98	3445	72,6	0,65	5,62	4,05	3,35					
4OS22T236	2,2	3	220	10,8	3425	75,7	0,71	5,53	3,63	2,90	1,15	11,6	35	4x1.5	2,5
			230	11,9	3440	72,6	0,64	5,32	4,04	3,22					
4OS30T236	3	4	220	13,2	3455	76,3	0,79	5,41	2,44	2,79	1,15	14,5	35	4x1,5	2,5
			230	13,8	3470	75,7	0,72	5,46	2,72	3,11					
4OS40T236	4	5,5	220	15,7	3435	78,9	0,85	5,85	1,81	2,70	1,15	17,7	35	4x1.5	2,5
			230	15,7	3455	78,8	0,81	6,17	2,02	3,01					
4OS55T236	5,5	7,5	220	21,4	3415	78,6	0,86	5,48	1,63	2,51	1,15	24,4	35	4x2.5	2,5
			230	21,2	3440	78,5	0,83	5,81	1,82	2,79					
4OS75T236	7,5	10	220	33,5	3460	78,7	0,75	6,28	2,53	3,41	1,15	36,8	35	4x2.5	4
			230	35,4	3475	77,6	0,68	6,26	2,81	3,79					
4OS03T386	0,37	0,5	380	1,55	3485	58,5	0,62	6,40	5,71	4,73	1,6	1,83	35	4x1.5	1,75
4OS05T386	0,55	0,75	380	1,88	3430	62,3	0,71	5,52	4,40	3,22	1,5	2,31	35	4x1.5	1,75
4OS07T386	0,75	1	380	2,62	3450	66,3	0,66	5,58	4,23	3,27	1,4	3,01	35	4x1.5	1,75
4OS11T386	1,1	1,5	380	3,27	3425	71,5	0,72	5,45	3,80	2,89	1,3	3,77	35	4x1.5	1,75
4OS15T386	1,5	2	380	4,30	3430	74,4	0,71	5,73	3,64	3,01	1,25	4,85	35	4x1.5	1,75
4OS22T386	2,2	3	380	6,25	3425	75,7	0,71	5,53	3,63	2,90	1,15	6,69	35	4x1.5	2,5
4OS30T386	3	4	380	7,61	3455	76,3	0,79	5,41	2,44	2,79	1,15	8,35	35	4x1,5	2,5
4OS40T386	4	5,5	380	9,05	3435	78,9	0,85	5,85	1,81	2,70	1,15	10,2	35	4x1.5	2,5
4OS55T386	5,5	7,5	380	12,3	3415	78,6	0,86	5,48	1,63	2,51	1,15	14,1	35	4x1.5	2,5
4OS75T386	7,5	10	380	19,4	3460	78,7	0,75	6,28	2,53	3,41	1,15	21,2	35	4x1.5	4

Ts/Tn = ratio between starting torque and nominal torque.

Tmax/Tn = ratio between maximum torque and nominal torque.

4ost-2p60-en\_b\_te



## 4" Submersible motors

### L4C Series 60 Hz



Submersible canned motors.  
The choice of component materials ensures optimum operating performances, superior quality, reliability and ease of installation.

#### SPECIFICATIONS

- **Stainless steel** outer sleeve.
- Shaft extension and coupling dimensions to **NEMA** standards.
- Class **F insulation**.
- Protection class: **IP68**.
- Compensating bellows for internal liquid expansion.
- Axial load supported by Kingsbury type thrust bearing.
- **Lip seal** protected by sand guard.
- Maximum **immersion depth**: 300 m.
- Maximum **number of starts per hour** at regular intervals:  
40 for direct start;  
20 for impedance start.
- Maximum supply **voltage variations** allowed :  $\pm 6\%$ .
- Maximum water **temperature**: 35°C.  
Max. temperature applies to motors working in a installation capable of delivering a flow of water around the motor jacket of at least 0,3 m/s.
- **Axial thrust**:  
2000 N from 0,37 to 1,1 kW;  
3000 N from 1,5 to 2,2 kW;  
6000 N from 3 to 7,5 kW.
- **Extractable supply cable** fitted with watertight connector.
- **Versions**:  
- Single-phase:  
0,37 to 3,7 kW 220-230 V, 60 Hz  
0,37 to 0,75 kW 110-115 V, 60 Hz  
(0,37 to 0,75 kW with built in automatic reset overload protection).  
- Three-phase:  
0,37 to 5,5 kW 220-230 V, 60 Hz  
0,37 to 7,5 kW 380 V, 60 Hz.
- Can also operate in horizontal position, provided that the associated pump can apply an axial thrust of at least 100 N on the entire operating field.

#### OPTIONAL FEATURES

- Special voltages.
- Inverter applications.

**High starting torque**

**Power supply cable with extractable connector**

## L4C MOTOR SERIES MOTOR CROSS SECTION AND TABLE OF MATERIALS

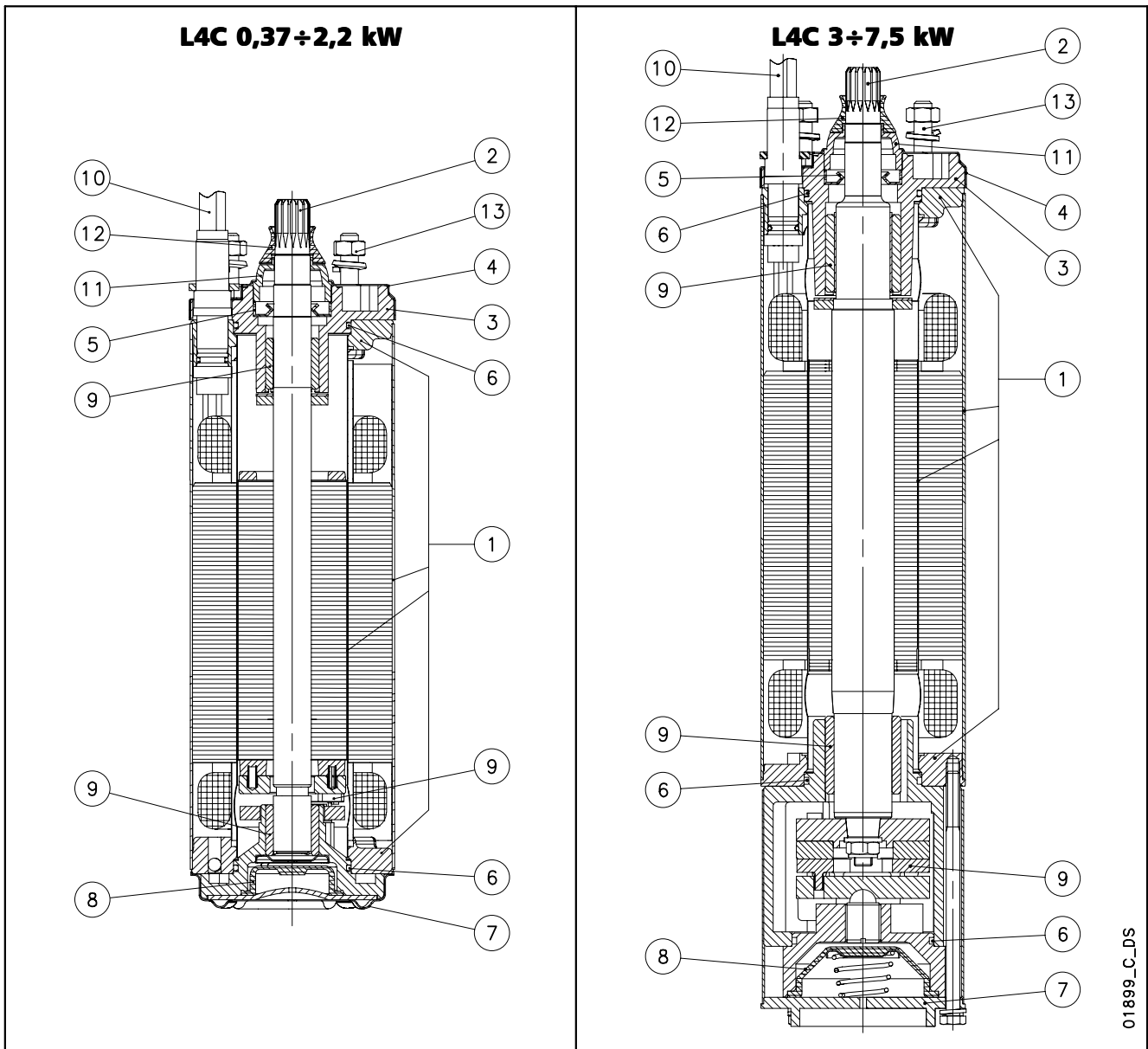

01899\_C\_DS

REF N°	PART	MATERIAL	DESIGNATION	
			EUROPE	USA
1	Inner, outer sleeves and flanges	Stainless steel	EN 10088-1-X2CrNi18-9 (1.4307)	AISI 304L
2	Shaft extension (up to 2.2 kW)	Stainless steel	EN 10088-1-X5CrNi18-10 (1.4301)	AISI 304
	Shaft extension (from 3 kW)	Stainless steel	EN 10088-3-X3CrNiMoN27 (1.4460)	AISI 329
3	Upper bracket	Cast iron	EN-GJL-200 EN 1561	Class 25 B
4	Upper cover	Stainless steel	EN 10088-1-X5CrNi18-10 (1.4301)	AISI 304
5	Lip seal	NBR		
6	Elastomers	NBR		
7	Lower cover	Stainless steel	EN 10088-1-X5CrNi18-10 (1.4301)	AISI 304
8	Compensating bellows	EPDM		
9	Bearings	Carbon-graphite		
10	Cable	EPDM		
11	Fixed sand guard	Nylon		
12	Removable sand guard	NBR		
13	Bolts and screws	Stainless steel	UNI EN ISO 3506-1 Grade A2	
	Cooling liquid	Demineralized water + antifreeze		

## L4C MOTOR SERIES IDENTIFICATION CODE

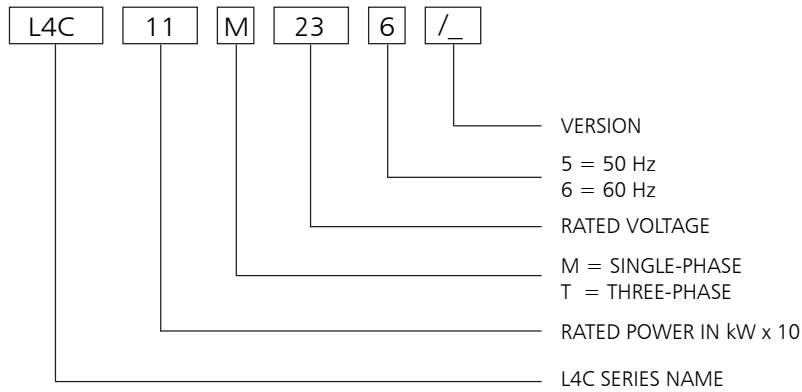

EXAMPLE : L4C11M236

L4C MOTOR :  
RATED POWER 1,1 kW; SINGLE-PHASE;  
RATED VOLTAGE 230 V; 60 Hz.

## RATING PLATE

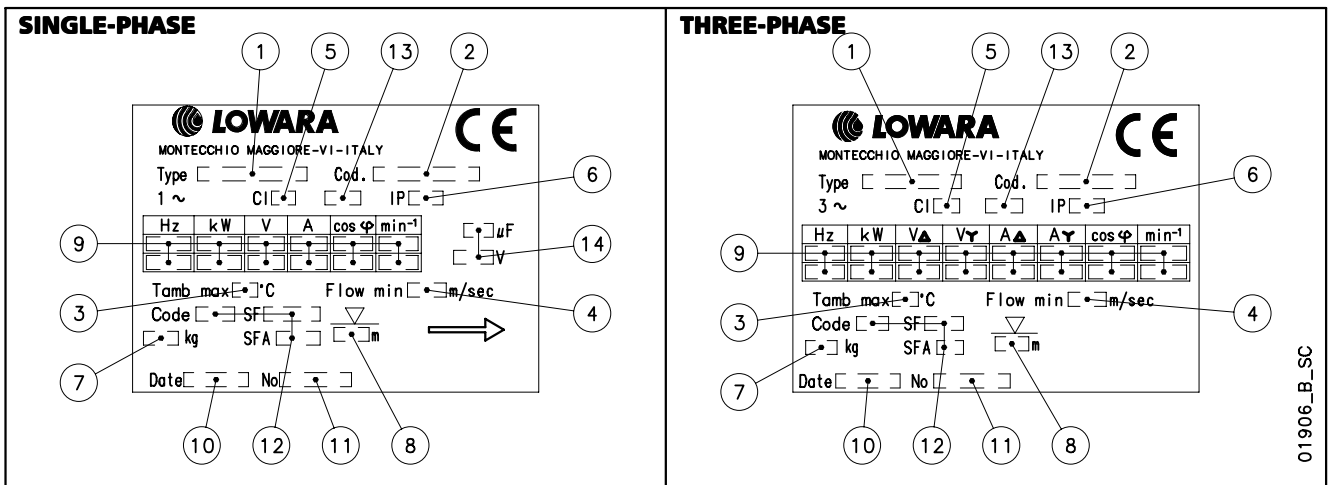

## LEGEND

- |                               |  |
|-------------------------------|--|
| 1 - Motor type                | 8 - Maximum immersion depth            |
| 2 - Code                      | 9 - Operating characteristics          |
| 3 - Maximum water temperature | 10 - Production date                   |
| 4 - Minimum water velocity    | 11 - Serial number                     |
| 5 - Insulation class          | 12 - Characteristics at service factor |
| 6 - Protection class          | 13 - Service type                      |
| 7 - Weight                    | 14 - Capacitor type                    |

## L4C MOTOR SERIES DIMENSIONS AND WEIGHTS AT 60 Hz

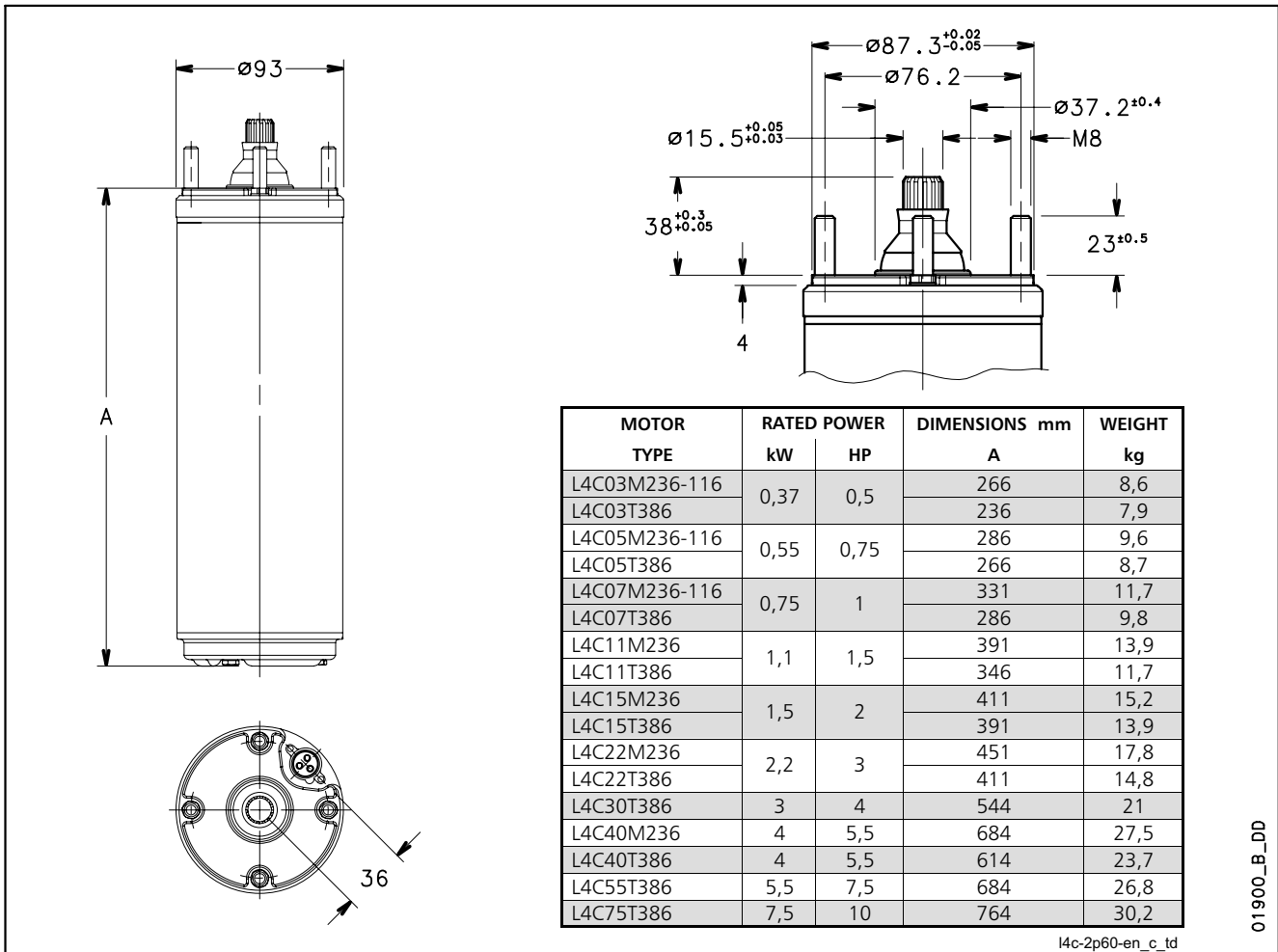

l4c-2p60-en\_c\_tld

## SINGLE-PHASE OPERATING CHARACTERISTICS AT 60 Hz

MOTOR TYPE	RATED POWER		SERVICE FACTOR	RATED VOLTAGE	CAPACITOR		OPERATING CHARACTERISTICS AT FULL (S.F.) POWER				DIRECT STARTING	MAX WATER TEMPERATURE °C	CABLE TYPE		
	kW	HP			μF	V	A	rpm	η %	cosφ			Ts/Tn*	Is/In	Nc x sec mm <sup>2</sup>
L4C03M236	0,37	0,5	1,6	220	20	450	5,3	3460	55,0	0,93	0,60	4,00	35	4x1.5	1,7
				230			5,5	3480	52,0	0,89	0,65	3,87			
L4C05M236	0,55	0,75	1,5	220	25	450	7,0	3460	60,0	0,89	0,60	3,90	35	4x1.5	1,7
				230			7,4	3485	57,0	0,84	0,65	3,70			
L4C07M236	0,75	1	1,4	220	35	450	8,5	3485	59,0	0,93	0,60	5,00	35	4x1.5	1,7
				230			8,9	3500	57,0	0,89	0,65	4,80			
L4C11M236	1,1	1,5	1,3	220	40	450	12,2	3480	61,0	0,88	0,66	4,30	35	4x1.5	1,7
				230			12,7	3485	58,0	0,84	0,72	4,10			
L4C15M236	1,5	2	1,25	220	50	450	13,1	3430	65,0	0,98	0,60	4,30	35	4x1.5	1,7
				230			12,8	3455	65,0	0,97	0,65	4,60			
L4C22M236	2,2	3	1,15	220	50	450	17,6	3410	68,0	0,96	0,44	3,30	35	4x1.5	1,7
				230			17,1	3420	67,0	0,96	0,48	3,60			
L4C40M236	4	5,5	1,15	220	75	450	30,7	3440	74,0	0,93	0,32	3,80	35	4x2	2,7
				230			29,7	3460	74,0	0,92	0,34	4,10			
L4C03M116	0,37	0,5	1,6	110	80	450	10,6	3460	55,0	0,93	0,60	4,00	35	4x1.5	1,7
				115			11,0	3480	52,0	0,89	0,65	3,87			
L4C05M116	0,55	0,75	1,5	110	100	450	14,0	3460	60,0	0,89	0,60	3,90	35	4x1.5	1,7
				115			14,8	3485	57,0	0,84	0,65	3,70			
L4C07M116	0,75	1	1,4	110	140	450	17,0	3485	59,0	0,93	0,60	5,00	35	4x1.5	1,7
				115			17,8	3500	57,0	0,89	0,65	4,80			

\* Ts/Tn = ratio between starting torque and nominal torque.

## L4C MOTOR SERIES

### THREE-PHASE OPERATING CHARACTERISTICS AT 60 Hz

MOTOR TYPE	RATED POWER		SERVICE FACTOR	RATED VOLTAGE	OPERATING CHARACTERISTICS AT FULL (S.F.) POWER				DIRECT STARTING		MAX WATER TEMPERATURE °C	CABLE TYPE	
	kW	HP			S. F.	V	A	rpm	$\eta$ %	$\cos\phi$		Ts/Tn*	Is/In
L4C03T236	0,37	0,5	1,6	220	3,5	3400	57,0	0,78	3,2	4,6	35	4x1.5	1,7
				230	3,8	3415	51,0	0,76	3,4	5,0			
L4C05T236	0,55	0,75	1,5	220	4,6	3440	58,0	0,82	3,6	5,1	35	4x1.5	1,7
				230	4,8	3450	56,0	0,77	4,0	5,4			
L4C07T236	0,75	1	1,4	220	5,3	3450	69,0	0,74	4,2	5,3	35	4x1.5	1,7
				230	5,6	3460	65,0	0,72	4,8	5,7			
L4C11T236	1,1	1,5	1,3	220	7,5	3450	68,0	0,75	4,1	6,0	35	4x1.5	1,7
				230	7,8	3465	65,0	0,72	4,5	6,6			
L4C15T236	1,5	2	1,25	220	9,4	3470	73,0	0,71	5,0	6,1	35	4x1.5	1,7
				230	9,8	3490	70,0	0,68	5,4	6,7			
L4C22T236	2,2	3	1,15	220	11,5	3450	76,0	0,77	4,8	6,6	35	4x1.5	1,7
				230	12	3470	72,0	0,75	5,2	7,1			
L4C30T236	3	4	1,15	220	16,5	3460	73,0	0,73	4,2	7,2	35	4x1,5	2,7
				230	17,3	3480	72,0	0,70	4,4	7,5			
L4C40T236	4	5,5	1,15	220	18,8	3470	82,0	0,80	4,0	6,8	35	4x2	2,7
				230	19,2	3490	78,0	0,78	4,4	7,4			
L4C55T236	5,5	7,5	1,15	220	25,4	3480	83,0	0,80	3,8	6,9	35	4x2	2,7
				230	26	3500	80,0	0,78	4,2	7,5			
L4C03T386	0,37	0,5	1,6	380	2,3	3415	51,0	0,76	3,2	5,2	35	4x1.5	1,7
L4C05T386	0,55	0,75	1,5	380	2,9	3450	56,0	0,77	3,6	5,8	35	4x1.5	1,7
L4C07T386	0,75	1	1,4	380	3,4	3460	65,0	0,72	4,2	5,8	35	4x1.5	1,7
L4C11T386	1,1	1,5	1,3	380	4,7	3465	65,0	0,72	4,1	6,6	35	4x1.5	1,7
L4C15T386	1,5	2	1,25	380	5,9	3490	70,0	0,68	5,0	6,8	35	4x1.5	1,7
L4C22T386	2,2	3	1,15	380	7,2	3470	72,0	0,75	4,8	7,1	35	4x1.5	1,7
L4C30T386	3	4	1,15	380	9,5	3460	73,0	0,73	4,2	7,2	35	4x1,5	1,7
L4C40T386	4	5,5	1,15	380	11,6	3490	78,0	0,78	4,0	7,5	35	4x1.5	2,7
L4C55T386	5,5	7,5	1,15	380	15,7	3500	80,0	0,78	3,8	7,5	35	4x1.5	2,7
L4C75T386	7,5	10	1,15	380	20	3480	81,0	0,80	3,9	7,1	35	4x2	3,5

\* Ts/Tn = ratio between starting torque and nominal torque.

l4ct-2p60-en\_d\_te





## **ACCESSORIES**

Pump-panel combination table .....	<b>50</b>
Electric panels .....	<b>52</b>
Level control panels .....	<b>60</b>
Level probe module .....	<b>61</b>
Lightning protection .....	<b>62</b>
Cooling shrouds .....	<b>63</b>

## SCUBA SERIES PUMP - PANEL COMBINATION TABLE

PUMP TYPE THREE-PHASE	MOTOR POWER		ABSORBED CURRENT* 380-400 V A	CAPACITOR $\mu$ F / 450 V	PANEL TYPE					
	kw	HP			QTD/...	Q3D/...				
SC2076T	0,75	1	1,73	-	...05	...05				
SC2096T	0,9	1,2	2,03	-	...11	...11				
SC2116T	1,1	1,5	2,37	-	...11	...11				
SC4076T	0,75	1	1,75	-	...05	...05				
SC4096T	0,9	1,2	2,00	-	...11	...11				
SC4116T	1,1	1,5	2,48	-	...11	...11				

\*Maximum values within operating range

scuba-sc2-sc4-2p60\_b\_tp

For different voltages (e.g. 220-240 V) please contact our sales network

## 4OS - L4C MOTOR SERIES MOTOR - CONTROL PANEL COMBINATION TABLE

MOTOR TYPE 4OS - 4" SINGLE-PHASE	RATED POWER		CURRENT AT S.F. 220-230 V	CAPACITOR	PANEL TYPE				
	kW	HP	A	μF / 450 V	QSC...	QSCS...			
	0,37	0,5	4,50	20	...036	...036			
0,55	0,75	6,23	25	...056	...056				
0,75	1	7,41	35	...076	...076				
1,1	1,5	9,34	40	...116	...116				
1,5	2	12,2	50	...156	...156				
2,2	3	17,1	50	...226	...226				

For different voltages, please contact our sales network.

4OSM-2p60-en\_b\_tc

MOTOR TYPE 4OS - 4" THREE-PHASE	RATED POWER		CURRENT AT S.F. 380 V	PANEL TYPE					
	kW	HP	A	QTD/...	Q3D/...	Q3I/...	Q3A/...	*Q3Y/...	Q3SF/...
	0,37	0,5	1,83	...05-07	...05-07	-	-	-	-
0,55	0,75	2,31	...05-07	...05-07	-	-	-	-	
0,75	1	3,01	...07-15	...07-15	-	-	-	-	
1,1	1,5	3,77	...07-15	...07-15	-	-	-	-	
1,5	2	4,85	...15-22	...15-22	-	-	-	-	
2,2	3	6,69	...22-40	...22-40	-	-	-	-	
3	4	8,35	...22-40	...22-40	-	-	-	-	
4	5,5	10,2	...40-75	...40-75	...40-75	...40-75	...40-75	...75	
5,5	7,5	14,1	...40-75	...40-75	...40-75	...40-75	...40-75	...75	
7,5	10	21,2	-	...92-110	...92-110	...92-110	...92-110	...150	

For different voltages, please contact our sales network.

4OST-2p60-en\_b\_tc

\* require 6-wire suitable motor

MOTOR TYPE L4C - 4" SINGLE PHASE	RATED POWER		CURRENT AT S.F. 220-230 V	CAPACITOR	PANEL TYPE				
	kW	HP	A	μF / 450 V	QSC/...	QSCS/...			
	0,37	0,5	5,5	20	...036	...036			
0,55	0,75	7,4	25	...056A	...056A				
0,75	1	8,9	35	...076	...076				
1,1	1,5	12,7	40	...116A	...116A				
1,5	2	13,1	50	...156	...156				
2,2	3	17,6	50	...226	...226				
3,7	5	30,7	75	...406	...406				

For different voltages please contact our sales network

L4cm-2p60\_d\_tc

MOTOR TYPE L4C - 4" THREE PHASE	RATED POWER		CURRENT AT S.F. 380 V	PANEL TYPE					
	kW	HP	A	QTD/...	Q3D/...	Q3I/...	Q3A/...	*Q3Y/...	Q3SF/...
	0,37	0,5	2,3	...05-07	...05-07	-	-	-	-
0,55	0,75	2,9	...07-15	...07-15	-	-	-	-	
0,75	1	3,4	...07-15	...07-15	-	-	-	-	
1,1	1,5	4,7	...15-22	...15-22	-	-	-	-	
1,5	2	5,9	...15-22	...15-22	-	-	-	-	
2,2	3	7,2	...22-40	...22-40	-	-	-	-	
3	4	9,5	...22-40	...22-40	-	-	-	...75	
4	5,5	11,6	...40-75	...40-75	...40-75	...40-75	...40-75	...75	
5,5	7,5	15,7	...40-75	...40-75	...40-75	...40-75	...40-75	...75	
7,5	10	20	-	...92-110	...92-110	...92-110	...92-110	...150	

For different voltages please contact our sales network

L4ct-2p60\_b\_tc

\* Require 6-wire suitable motor

## Single-phase Electric Panel

### APPLICATIONS

- Protection and control of a single-phase submersible electric pump for 4" wells.

## QSC Series (60 Hz)



### SPECIFICATIONS

- Main switch for manual control.
- Supply voltage: 1 x 230 V  $\pm$  10%.
- Frequency: 60 Hz.
- Power: 0,37 to 4 kW.
- Direct motor start.
- Protection class: IP55.
- Ambient temperature: -5 to +40 °C (according to EN 60439-1).
- Maximum relative humidity: 50% at +40°C, provided that no condensation occurs (according to EN 60439-1).
- Wall mounted.
- Plastic enclosure.
- Incorporated capacitor.
- Main switch with thermal protection.

### OPTIONAL ACCESSORIES

- DPF single-phase module for overvoltage protection (lightning protector).

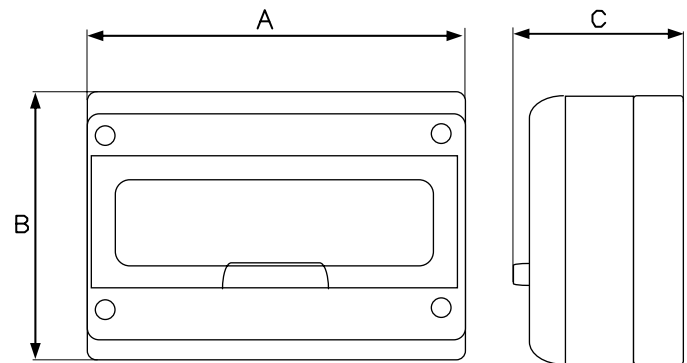

MODEL	RATED VOLTAGE V	RATED POWER		RATED CURRENT A	DIMENSIONS			WEIGHT Kg	CAPACITOR $\mu$ F/450V
		kW	HP		A mm	B mm	C mm		
QSC/036	1 x 230 V $\pm$ 10 %	0,37	0,5	4 $\div$ 6,3	205	220	160	1,7	20
QSC/056	1 x 230 V $\pm$ 10 %	0,55	0,75	4 $\div$ 6,3	205	220	160	1,7	25
QSC/056A	1 x 230 V $\pm$ 10 %	0,55	0,75	6,3 $\div$ 10	205	220	160	1,7	25
QSC/076	1 x 230 V $\pm$ 10 %	0,75	1	6,3 $\div$ 10	205	220	160	1,7	35
QSC/116	1 x 230 V $\pm$ 10 %	1,1	1,5	6,3 $\div$ 10	205	220	160	1,7	40
QSC/116A	1 x 230 V $\pm$ 10 %	1,1	1,5	10 $\div$ 16	205	220	160	1,7	40
QSC/156	1 x 230 V $\pm$ 10 %	1,5	2	10 $\div$ 16	205	220	160	1,7	50
QSC/226	1 x 230 V $\pm$ 10 %	2,2	3	16 $\div$ 20	205	220	160	2,7	50
QSC/406	1 x 230 V $\pm$ 10 %	4	5,5	25 $\div$ 32	280	220	160	3	75

## Single-phase Electric Panel

### APPLICATIONS

- Protection and control of a single-phase submersible electric pump for 4" wells.

## QSCS Series (60 Hz)



### SPECIFICATIONS

- Automatic control through an external enable contact.
- Supply voltage: 1 x 230 V  $\pm$  10%.
- Frequency: 60 Hz.
- Power: 0,37 to 2,2 kW.
- Direct motor start.
- Protection class: IP55.
- Ambient temperature: -5 to +40 °C (according to EN 60439-1).
- Maximum relative humidity: 50% at +40°C, provided that no condensation occurs (according to EN 60439-1).
- Wall mounted.
- Plastic enclosure.
- Incorporated capacitor.

- Main switch with thermal protection.
- Dry running control with float or minimum pressure switch (available separately).

### OPTIONAL ACCESSORIES

- DPF single-phase module for overvoltage protection (lightning protector).
- KSL series 24 V level kit. Probe module for protection against dry running (set of three electrodes included in the supply).

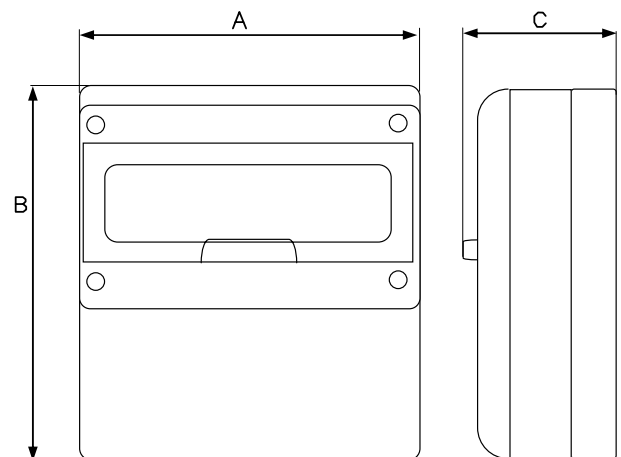

MODEL	RATED VOLTAGE V	RATED POWER		RATED CURRENT A	DIMENSIONS			WEIGHT Kg	CAPACITOR $\mu$ F/450V
		kW	HP		A mm	B mm	C mm		
QSCS/036	1 x 230 V $\pm$ 10 %	0,37	0,5	4 $\div$ 6,3	280	370	160	3,7	20
QSCS/056	1 x 230 V $\pm$ 10 %	0,55	0,75	4 $\div$ 6,3	280	370	160	3,7	25
QSCS/056A	1 x 230 V $\pm$ 10 %	0,55	0,75	6,3 $\div$ 10	280	370	160	3,7	25
QSCS/076	1 x 230 V $\pm$ 10 %	0,75	1	6,3 $\div$ 10	280	370	160	3,7	35
QSCS/116	1 x 230 V $\pm$ 10 %	1,1	1,5	6,3 $\div$ 10	280	370	160	3,7	40
QSCS/116A	1 x 230 V $\pm$ 10 %	1,1	1,5	10 $\div$ 16	280	370	160	3,7	40
QSCS/156	1 x 230 V $\pm$ 10 %	1,5	2	10 $\div$ 16	280	370	160	3,7	50
QSCS/226	1 x 230 V $\pm$ 10 %	2,2	3	16 $\div$ 20	280	370	160	3,7	50
QSCS/406	1 x 230 V $\pm$ 10 %	4	5,5	25 $\div$ 32	280	370	160	4	75

CB-QSCS6-en\_d\_te

## Three-phase Electric Panel

### APPLICATIONS

- Protection and control of a three-phase surface or submersible electric pump.

## QTD Series



### SPECIFICATIONS

- Control through an external enable contact.
- Supply voltage: 3 x 400 V  $\pm$  10%.
- Frequency: 50/60 Hz.
- Power: 0,25 to 9,2 kW.
- Direct motor start.
- Short-circuit and overload protection.
- Protection class: IP54.
- Ambient temperature: -5 to +40 °C (according to EN 60439-1).
- Maximum relative humidity: 50% at +40°C, provided that no condensation occurs (according to EN 60439-1).
- Wall mounted.
- Metal enclosure.
- Ready for installation of dry running control float or pressure switch (to be ordered separately).
- Power and thermal overload indicator lights.

### OPTIONAL ACCESSORIES

- VR3 three-phase module for overvoltage protection (lightning protector).
- KSL series 24 V level kit. Probe module for protection against dry running (set of three electrodes included in the supply).

### SELECTION

- For a suitable choice of control panel, be sure the electrical input of the motor (Ampere) is included in the rated current value mentioned in the table below.

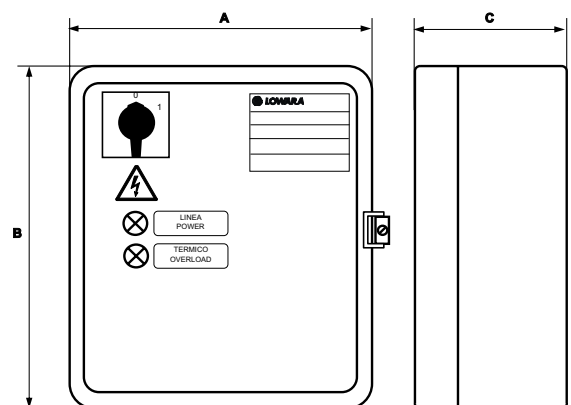

MODEL	RATED VOLTAGE V	RATED POWER		RATED CURRENT A	DIMENSIONS			WEIGHT Kg
		kW	HP		A mm	B mm	C mm	
QTD/02-03	3 x 400 V $\pm$ 10 %	0,25-0,37	0,33-0,50	0,63 ÷ 1	235	265	150	5,8
QTD/03-05	3 x 400 V $\pm$ 10 %	0,37-0,55	0,55-0,75	1 ÷ 1,6	235	265	150	5,8
QTD/05-07	3 x 400 V $\pm$ 10 %	0,55-0,75	0,75-1	1,6 ÷ 2,5	235	265	150	5,8
QTD/07-15	3 x 400 V $\pm$ 10 %	0,75-1,5	1-2	2,5 ÷ 4	235	265	150	5,8
QTD/15-22	3 x 400 V $\pm$ 10 %	1,5-2,2	2-3	4 ÷ 6,3	235	265	150	5,8
QTD/22-40	3 x 400 V $\pm$ 10 %	2,2-4	3-5,5	6,3 ÷ 10	235	265	150	5,8
QTD/40-75	3 x 400 V $\pm$ 10 %	4-7,5	5,5-10	10 ÷ 16	235	265	150	5,8
QTD/75-92	3 x 400 V $\pm$ 10 %	7,5-9,2	10-12,5	16 ÷ 20	235	265	150	5,8

## Three-phase Electric Panel

### APPLICATIONS

- Protection and control of a three-phase surface or submersible electric pump.

## Q3D Series



### SPECIFICATIONS

- Manual control through an Auto/Man selector switch.
- Automatic control through an external enable contact.
- Supply voltage: 3 x 400 V  $\pm$  10%.
- Frequency: 50/60 Hz.
- 24 V AC low voltage auxiliary circuit.
- Power: 0,25 to 37 kW.
- Direct motor start.
- Short-circuit and overload protection.
- Protection class: IP54.
- Ambient temperature: -5 to +40 °C (according to EN 60439-1).
- Maximum relative humidity: 50% at +40°C, provided that no condensation occurs (according to EN 60439-1).
- Wall mounted.
- Metal enclosure.
- Power, pump running, thermal overload and dry running indicator lights.

- Ready for installation of dry running control float or pressure switch (to be ordered separately). Can be equipped with electronic protection module with electrodes.

### OPTIONAL ACCESSORIES

- KSL series 24 V level kit. Probe module for protection against dry running (set of three electrodes included in the supply).
- Float.
- Pressure switch.
- VR3/SCA3 three-phase module for overvoltage protection (lightning protector).

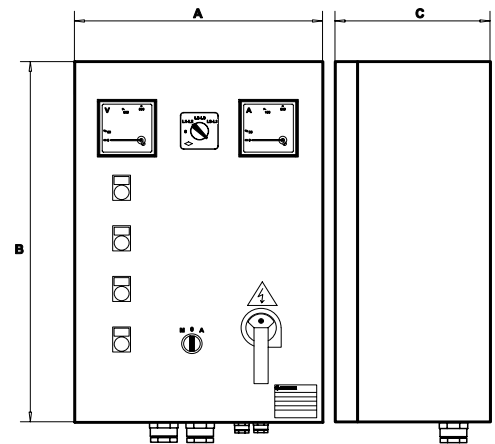

MODEL	RATED VOLTAGE V	RATED POWER		RATED CURRENT A	DIMENSIONS			WEIGHT Kg
		kW	HP		A mm	B mm	C mm	
Q3D/02-03	3 x 400 V $\pm$ 10 %	0,25-0,37	0,33-0,50	0,63 $\div$ 1	300	400	200	15
Q3D/03-05	3 x 400 V $\pm$ 10 %	0,37-0,55	0,5-0,75	1 $\div$ 1,6	300	400	200	15
Q3D/05-07	3 x 400 V $\pm$ 10 %	0,55-0,75	0,75-1	1,6 $\div$ 2,5	300	400	200	15
Q3D/07-15	3 x 400 V $\pm$ 10 %	0,75-1,5	1-2	2,5 $\div$ 4	300	400	200	15
Q3D/15-22	3 x 400 V $\pm$ 10 %	1,5-2,2	2-3	4 $\div$ 6,3	300	400	200	15
Q3D/22-40	3 x 400 V $\pm$ 10 %	2,2-4	3-5,5	6,3 $\div$ 10	300	400	200	15
Q3D/40-75	3 x 400 V $\pm$ 10 %	4-7,5	5,5-10	10 $\div$ 16	300	400	200	15
Q3D/75-92	3 x 400 V $\pm$ 10 %	7,5-9,2	10-12,5	16 $\div$ 20	300	400	200	15
Q3D/92-110	3 x 400 V $\pm$ 10 %	9,2-11	12,5-15	20 $\div$ 25	300	400	200	20
Q3D/110-150	3 x 400 V $\pm$ 10 %	11-15	15-20	22 $\div$ 32	400	500	200	20
Q3D/150-185	3 x 400 V $\pm$ 10 %	15-18,5	20-25	28 $\div$ 40	400	500	200	20
Q3D/185-220	3 x 400 V $\pm$ 10 %	18,5-22	25-30	36 $\div$ 50	400	600	200	27
Q3D/220-300	3 x 400 V $\pm$ 10 %	22-30	30-40	45 $\div$ 63	400	600	200	27
Q3D/300-370	3 x 400 V $\pm$ 10 %	30-37	40-50	57 $\div$ 75	400	600	200	27

## Three-phase Electric Panel

### Q3Y Series



### APPLICATIONS

- Protection and control of a three-phase surface or submersible electric pump.

### SPECIFICATIONS

- Manual control through an Auto/Man selector switch.
- Automatic control through an external enable contact.
- Supply voltage: 3 x 400 V  $\pm$  10%.
- Frequency: 50/60 Hz.
- 24 V AC low voltage auxiliary circuit.
- Power: 4 to 315 kW.
- Star-delta starting.
- Short-circuit and overload protection.
- Protection class: IP54.
- Ambient temperature: -5 to +40 °C (according to EN 60439-1).
- Maximum relative humidity: 50% at +40°C, provided that no condensation occurs (according to EN 60439-1).
- Wall mounted.
- Metal enclosure.
- Power, pump running, thermal overload and dry running indicator lights.

- Ready for installation of dry running control float or pressure switch (to be ordered separately). Can be equipped with electronic protection module with electrodes.

### OPTIONAL ACCESSORIES

- KSL series 24 V level kit. Probe module for protection against dry running (set of three electrodes included in the supply).
- Float.
- Pressure switch.
- VR3/SCA3 three-phase module for overvoltage protection (lightning protector).

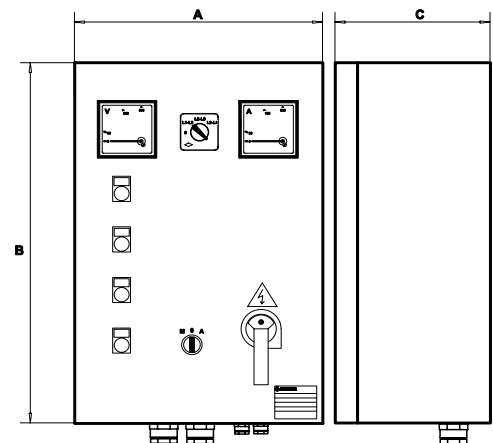

MODEL	RATED VOLTAGE V	RATED POWER		RATED CURRENT A	DIMENSIONS			WEIGHT Kg
		kW	HP		A mm	B mm	C mm	
Q3Y/40-75	3 x 400 V $\pm$ 10 %	4-7,5	5,5-10	10 $\div$ 16	400	600	200	23
Q3Y/75-92	3 x 400 V $\pm$ 10 %	7,5-9,2	10-12,5	16 $\div$ 20	400	600	200	23
Q3Y/92-110	3 x 400 V $\pm$ 10 %	9,2-11	12,5-15	20 $\div$ 25	400	600	200	23
Q3Y/110-150	3 x 400 V $\pm$ 10 %	11-15	15-20	22 $\div$ 32	400	600	200	23
Q3Y/150-185	3 x 400 V $\pm$ 10 %	15-18,5	20-25	28 $\div$ 40	400	600	200	23
Q3Y/185-220	3 x 400 V $\pm$ 10 %	18,5-22	25-30	36 $\div$ 50	500	700	200	32
Q3Y/220-300	3 x 400 V $\pm$ 10 %	22-30	30-40	45 $\div$ 63	500	700	200	32
Q3Y/300-370	3 x 400 V $\pm$ 10 %	30-37	40-50	57 $\div$ 75	600	800	250	68
Q3Y/370-450	3 x 400 V $\pm$ 10 %	37-45	50-60	70 $\div$ 90	600	800	250	80
Q3Y/450-550	3 x 400 V $\pm$ 10 %	45-55	60-75	80 $\div$ 108	600	900	250	80
Q3Y/550-750	3 x 400 V $\pm$ 10 %	55-75	75-100	105 $\div$ 138	600p	1300p	300p	109
Q3Y/750-900	3 x 400 V $\pm$ 10 %	75-90	100-125	138 $\div$ 185	600p	1300p	300p	109
Q3Y/900-1100	3 x 400 V $\pm$ 10 %	90-110	125-150	175 $\div$ 210	600p	1500p	300p	120
Q3Y/1100-1320	3 x 400 V $\pm$ 10 %	110-132	150-180	210 $\div$ 260	800p	1700p	400p	130
Q3Y/1320-1600	3 x 400 V $\pm$ 10 %	132-160	180-218	250 $\div$ 305	800p	1700p	400p	130
Q3Y/1600-2000	3 x 400 V $\pm$ 10 %	160-200	218-273	290 $\div$ 400	800p	1900p	400p	140
Q3Y/2000-2500	3 x 400 V $\pm$ 10 %	200-250	273-340	400 $\div$ 460	1000p	1900p	400p	180
Q3Y/2500-3150	3 x 400 V $\pm$ 10 %	250-315	340-430	450 $\div$ 580	1000p	1900p	400p	180

Dimensions note : P indicates floor mounted control panel.

CB-Q3Y-en\_c\_te



## Three-phase Electric Panel

### Q3I Series



### APPLICATIONS

- Protection and control of a three-phase surface or submersible electric pump.

### SPECIFICATIONS

- Manual control through an Auto/Man selector switch.
- Automatic control through an external enable contact.
- Supply voltage: 3 x 400 V  $\pm$  10%.
- Frequency: 50/60 Hz.
- 24 V AC low voltage auxiliary circuit.
- Power: 4 to 315 kW.
- Impedance start.
- Short-circuit and overload protection.
- Protection class: IP54.
- Ambient temperature: -5 to +40 °C (according to EN 60439-1).
- Maximum relative humidity: 50% at +40°C, provided that no condensation occurs (according to EN 60439-1).
- Wall mounted.
- Metal enclosure.
- Power, pump running, thermal overload and dry running indicator lights.

- Ready for installation of dry running control float or pressure switch (to be ordered separately). Can be equipped with electronic protection module with electrodes.

### OPTIONAL ACCESSORIES

- KSL series 24 V level kit. Probe module for protection against dry running (set of three electrodes included in the supply).
- Float.
- Pressure switch.
- VR3/SCA3 three-phase module for overvoltage protection (lightning protector).

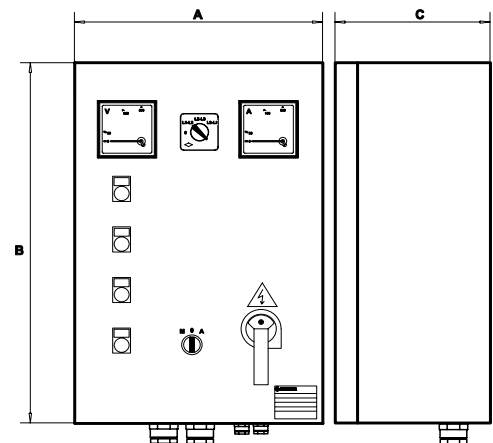

MODEL	RATED VOLTAGE V	RATED POWER		RATED CURRENT A	DIMENSIONS			WEIGHT Kg
		kW	HP		A mm	B mm	C mm	
Q3I/40-75	3 x 400 V $\pm$ 10 %	4-7,5	5,5-10	10 $\div$ 16	400	600	250	35
Q3I/75-92	3 x 400 V $\pm$ 10 %	7,5-9,2	10-12,5	16 $\div$ 20	400	600	250	35
Q3I/92-110	3 x 400 V $\pm$ 10 %	9,2-11	12,5-15	20 $\div$ 25	400	600	250	35
Q3I/110-150	3 x 400 V $\pm$ 10 %	11-15	15-20	22 $\div$ 32	500	700	250	50
Q3I/150-185	3 x 400 V $\pm$ 10 %	15-18,5	20-25	28 $\div$ 40	500	700	250	50
Q3I/185-220	3 x 400 V $\pm$ 10 %	18,5-22	25-30	36 $\div$ 50	500	700	250	50
Q3I/220-300	3 x 400 V $\pm$ 10 %	22-30	30-40	45 $\div$ 63	500	700	250	65
Q3I/300-370	3 x 400 V $\pm$ 10 %	30-37	40-50	57 $\div$ 75	500	700	250	65
Q3I/370-450	3 x 400 V $\pm$ 10 %	37-45	50-60	70 $\div$ 90	600	900	250	65
Q3I/450-550	3 x 400 V $\pm$ 10 %	45-55	60-75	80 $\div$ 108	600p	1300p	300p	100
Q3I/550-750	3 x 400 V $\pm$ 10 %	55-75	75-100	105 $\div$ 138	600p	1300p	300p	100
Q3I/750-900	3 x 400 V $\pm$ 10 %	75-90	100-125	138 $\div$ 185	600p	1500p	300p	100
Q3I/900-1100	3 x 400 V $\pm$ 10 %	90-110	125-150	175 $\div$ 210	800p	1700p	400p	100
Q3I/1100-1320	3 x 400 V $\pm$ 10 %	110-132	150-180	210 $\div$ 260	800p	1700p	400p	150
Q3I/1320-1600	3 x 400 V $\pm$ 10 %	132-160	180-218	250 $\div$ 305	800p	1700p	400p	150
Q3I/1600-2000	3 x 400 V $\pm$ 10 %	160-200	218-273	290 $\div$ 400	800p	1900p	400p	160
Q3I/2000-2500	3 x 400 V $\pm$ 10 %	200-250	273-340	400 $\div$ 460	1000p	1900p	400p	180
Q3I/2500-3150	3 x 400 V $\pm$ 10 %	250-315	340-430	450 $\div$ 580	1000p	1900p	400p	200

Dimensions note : P indicates floor mounted control panel.

CB-Q3I-en\_c\_te

## Three-phase Electric Panel

### Q3A Series



### APPLICATIONS

- Protection and control of a three-phase surface or submersible electric pump.

### SPECIFICATIONS

- Manual control through an Auto/Man selector switch.
- Automatic control through an external enable contact.
- Supply voltage: 3 x 400 V  $\pm$  10%.
- Frequency: 50/60 Hz.
- 24 V AC low voltage auxiliary circuit.
- Power: 4 to 315 kW.
- Starting autotransformer.
- Short-circuit and overload protection.
- Protection class: IP54.
- Ambient temperature: -5 to +40 °C (according to EN 60439-1).
- Maximum relative humidity: 50% at +40°C, provided that no condensation occurs (according to EN 60439-1).
- Wall mounted.
- Metal enclosure.
- Power, pump running, thermal overload and dry running indicator lights.

- Ready for installation of dry running control float or pressure switch (to be ordered separately). Can be equipped with electronic protection module with electrodes.

### OPTIONAL ACCESSORIES

- KSL series 24 V level kit. Probe module for protection against dry running (set of three electrodes included in the supply).
- Float.
- Pressure switch.
- VR3/SCA3 three-phase module for overvoltage protection (lightning protector).

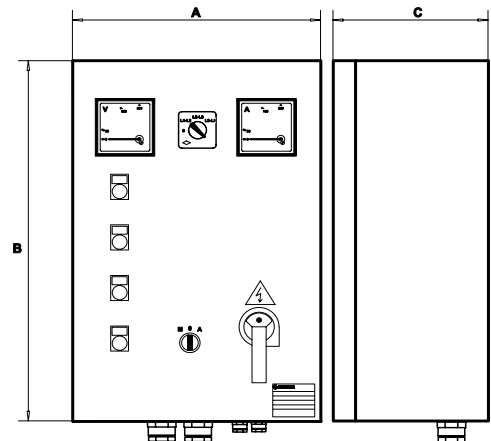

MODEL	RATED VOLTAGE V	RATED POWER		RATED CURRENT A	DIMENSIONS			WEIGHT Kg
		kW	HP		A mm	B mm	C mm	
Q3A/40-75	3 x 400 V $\pm$ 10 %	4-7,5	5,5-10	10 $\div$ 16	500	700	250	50
Q3A/75-92	3 x 400 V $\pm$ 10 %	7,5-9,2	10-12,5	16 $\div$ 20	500	700	250	50
Q3A/92-110	3 x 400 V $\pm$ 10 %	9,2-11	12,5-15	20 $\div$ 25	500	700	250	50
Q3A/110-150	3 x 400 V $\pm$ 10 %	11-15	15-20	22 $\div$ 32	500	700	250	50
Q3A/150-185	3 x 400 V $\pm$ 10 %	15-18,5	20-25	28 $\div$ 40	500	700	250	50
Q3A/185-220	3 x 400 V $\pm$ 10 %	18,5-22	25-30	36 $\div$ 50	500	700	250	50
Q3A/220-300	3 x 400 V $\pm$ 10 %	22-30	30-40	45 $\div$ 63	600	900	300	80
Q3A/300-370	3 x 400 V $\pm$ 10 %	30-37	40-50	57 $\div$ 75	600	900	300	80
Q3A/370-450	3 x 400 V $\pm$ 10 %	37-45	50-60	70 $\div$ 90	600p	1300p	300p	90
Q3A/450-550	3 x 400 V $\pm$ 10 %	45-55	60-75	80 $\div$ 108	600p	1500p	300p	120
Q3A/550-750	3 x 400 V $\pm$ 10 %	55-75	75-100	105 $\div$ 138	600p	1500p	300p	120
Q3A/750-900	3 x 400 V $\pm$ 10 %	75-90	100-125	138 $\div$ 185	600p	1700p	400p	150
Q3A/900-1100	3 x 400 V $\pm$ 10 %	90-110	125-150	175 $\div$ 210	800p	1900p	400p	150
Q3A/1100-1320	3 x 400 V $\pm$ 10 %	110-132	150-180	210 $\div$ 260	800p	1900p	400p	200
Q3A/1320-1600	3 x 400 V $\pm$ 10 %	132-160	180-218	250 $\div$ 305	800p	1900p	400p	200
Q3A/1600-2000	3 x 400 V $\pm$ 10 %	160-200	218-273	290 $\div$ 400	800p	1900p	400p	230
Q3A/2000-2500	3 x 400 V $\pm$ 10 %	200-250	273-340	400 $\div$ 460	1000p	1900p	400p	230
Q3A/2500-3150	3 x 400 V $\pm$ 10 %	250-315	340-430	450 $\div$ 580	1000p	1900p	400p	250

Dimensions note : P indicates floor mounted control panel.

CB-Q3A-en\_c\_te

## Three-phase Electric Panel

### Q3SF Series



### APPLICATIONS

- Protection and control of a three-phase surface or submersible electric pump.

### SPECIFICATIONS

- Manual control through an Auto/Man selector switch.
- Automatic control through an external enable contact.
- Supply voltage: 3 x 400 V  $\pm$  10%.
- Frequency: 50/60 Hz.
- 24 V AC low voltage auxiliary circuit.
- Power: 5,5 to 110 kW.
- Softstart with torque control.
- Protection class: IP54.
- Ambient temperature: -5 to +40 °C
- Maximum relative humidity: 50% at +40°C, provided that no condensation occurs (according to EN 60439-1).
- Wall mounted.
- Metal enclosure.
- Dry running indicator light.
- Power - pump running - malfunction LEDs on starter keypanel.
- ON/OFF selector switch for activation of by-pass contactor.
- Ready for installation of dry running control float or pressure switch (to be ordered separately). Can be equipped with electronic protection module with electrodes.

Protections against phase failure / phase sequence / frequency out of limits on power supply line.  
Low-voltage protection on auxiliary circuits.  
Protection against starter overtemperature / overload / malfunction.  
Protection against overload / locked rotor / current asymmetry on motor side.  
Short-circuit protection on inputs and outputs.  
RS232 interface for remote control and RS485 for use of remote keypanel.  
Incorporated by-pass contactor.

### OPTIONAL ACCESSORIES

- KSL series 24 V level kit. Probe module for protection against dry running (set of three electrodes included in the supply).
- Float.
- Pressure switch.
- VR3/SCA3 three-phase module for overvoltage protection (lightning protector).

### STATIC STARTER CHARACTERISTICS

- Static starter for gradual start-up/shutdown, featuring: keypanel with liquid crystal display showing voltage, absorbed current,  $\cos \Phi$ , operating hours, number of starts, last twenty messages on system status (events / alarms).

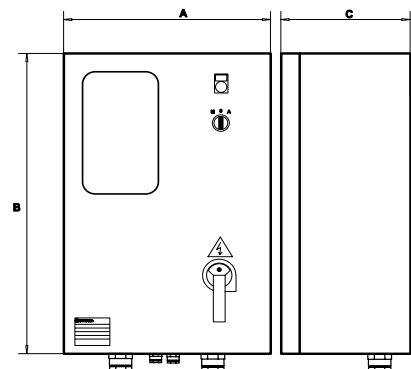

MODEL	RATED VOLTAGE V	RATED POWER		RATED CURRENT A	DIMENSIONS			WEIGHT Kg
		kW	HP		A mm	B mm	C mm	
Q3SF 75	3 x 400 V $\pm$ 10 %	5,5 - 7,5	7,5 - 10	8,5 $\div$ 17	400	600	250	35
Q3SF 150	3 x 400 V $\pm$ 10 %	9,2 - 15	12,5 - 20	15 $\div$ 30	500	700	250	40
Q3SF 220	3 x 400 V $\pm$ 10 %	18,5 - 22	25 - 30	28 $\div$ 45	500	700	250	40
Q3SF 300	3 x 400 V $\pm$ 10 %	30	40	42 $\div$ 60	600	900	300	90
Q3SF 370	3 x 400 V $\pm$ 10 %	37	50	55 $\div$ 75	600	900	300	90
Q3SF 450	3 x 400 V $\pm$ 10 %	45	60	70 $\div$ 85	600	900	300	90
Q3SF 550	3 x 400 V $\pm$ 10 %	55	75	80 $\div$ 110	600	900	300	90
Q3SF 590	3 x 400 V $\pm$ 10 %	59	80	105 $\div$ 125	600	900	300	90
Q3SF 750	3 x 400 V $\pm$ 10 %	75	100	120 $\div$ 142	600p	1700p	400p	120
Q3SF 900	3 x 400 V $\pm$ 10 %	90	125	135 $\div$ 190	600p	1700p	400p	120
Q3SF 1100	3 x 400 V $\pm$ 10 %	110	150	185 $\div$ 245	600p	1700p	400p	120

Dimensions note : P indicates floor mounted control panel.

CB-Q3SF-en\_b\_te

## Level Control Panel

### APPLICATIONS

- Accessory for electric pump control panels, suitable for tank filling or drainage applications or for activation of audible or visual alarms.

## QCL5 Series



### SPECIFICATIONS

- Automatic control through probes.
- Supply voltage:  
1 x 230 V  $\pm$ 10% or 1 x 24 V  $\pm$ 10%.
- Frequency: 50/60 Hz.
- Voltage to probes:  
15 V AC at 0,5 mA max.
- Switch contact 48 V AC at 3 A max (250 W max).
- Protection class: IP55.
- Ambient temperature: -5 to +40 °C (according to EN 60439-1).
- Maximum relative humidity: 50% at +40°C, provided that no condensation occurs (according to EN 60439-1).
- Wall mounted.
- Plastic enclosure.
- Electrodes suitable for water at a maximum temperature of 40°C.
- Set of three electrodes included in the supply.

### OPTIONAL ACCESSORIES

- Drop cable with circular cross section.

For connection of the electrodes to the panel we recommend the following cross sections:

LENGHT m		CABLE SECTION mm <sup>2</sup>
0	50	0,5
50	100	0,75
100	200	1,0
200	400	2,5

CB-CASEL-en\_b\_te

Three-pole cables can be used for short lengths.

Otherwise we recommend the use of unipolar cables placed at suitable distance from each other to prevent the capacitive effect of the cable from interfering with the proper operation of the electronic module.

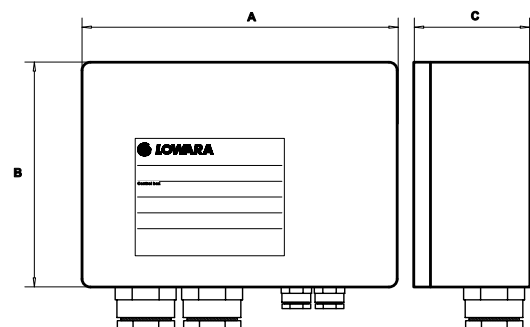

TYPE	POWER SUPPLY			CONTACT			DIMENSIONS A x B x C mm	WEIGHT Kg
	VOLTAGE V	FREQUENCY Hz	POWER W	TYPE	RANGE V	A		
QCL5/24	1 x 24	50/60	2	NO-C-NC	48	3	90 x 130 x 60	0,5
QCL5/230	1 x 230	50/60	2					

CB-QCL5-en\_a\_te

## Kit 24 V Level Probe

### APPLICATIONS

- Accessory for electric panels.

## KSL Series



### SPECIFICATIONS

- Electronic module for use of probes as protection against dry running.
- Supply voltage:  
1 x 24 V  $\pm$  10% for model SLD/24.
- Frequency: 50/60 Hz.
- Absorbed power: 3,5 VA max.
- Voltage to probes:  
7,5 V AC at 0,4 mA max.
- Switch contact 24 V AC at 5 A max (250 W max).
- Designed for installation on Lowara electric panels featuring DIN bar.
- Electrodes suitable for water at a maximum temperature of 60°C.

### CONSTRUCTION CHARACTERISTICS

- Module made of plastic material with DIN bar attachment.
- Cables with quick plug-in connectors.
- Set of three electrodes included in the supply.
- Electrodes with nylon 6 body, stainless steel sensitive element brass washer and nitrile rubber seal.

### OPTIONAL ACCESSORIES

- Drop cable with circular cross section.

For connection of the electrodes to the panel we recommend the following cross sections:

LENGHT m		CABLE SECTION mm <sup>2</sup>
0	50	0,5
50	100	0,75
100	200	1,0
200	400	2,5

CB-CASEL-en\_b\_te

Three-pole cables can be used for short lengths.

Otherwise we recommend the use of unipolar cables placed at suitable distance from each other to prevent the capacitive effect of the cable from interfering with the proper operation of the electronic module.

TYPE	POWER SUPPLY		CONTACT			DIMENSIONS A x B x C mm	WEIGHT Kg	PANELS	
	MAIN V	POWER VA	TYPE	RANGE V~	A				
KIT KSL/24	1x24	50/60 Hz	3,5	N0-C-NC	250	8	90 x 36 x 60	0,5	QSCS-QM-QTD-Q3D-Q3Y-Q3A-Q3I-Q3SF

CB-SLD-en\_b\_te

## Lightning Protection

### APPLICATIONS

- Accessory for electric panels.

## DPF Series

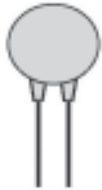

### SPECIFICATIONS

- Varistor for overvoltage protection of single-phase lines. To be connected between the phase and neutral conductor.
- Operating voltage: 460 V AC.
- Maximum varistor voltage: 750 V with 100 A peak current.

## VR Series



### SPECIFICATIONS

- Varistors for overvoltage protection of three-phase lines.
- To be connected between the phases (VR3 model).
- Operating voltage: 460 V AC.
- Maximum varistor voltage: 750 V with 100 A peak current.
- Designed for installation on Lowara electric panels featuring DIN bar.

## SCA3 Series

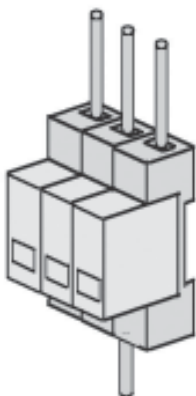

### SPECIFICATIONS

- Lightning arresters for overvoltage protection of three-phase lines. To be connected between the phases and the heart conductor,
- Operating voltage: 500 V AC.
- Maximum varistor voltage: 2,5 kW with 40 kA peak current.
- Designed for installation on Lowara electric panels featuring DIN bar.

TYPE	VOLTAGE V	PANELS
DPF	1 x 220-240 50/60 Hz	QSM - QSC - QSCS - QPC
KIT VR1	1 x 220-230 50/60 Hz	QM - QDRM - QDRM2 - QDRMC - QDRMC2
KIT VR3	3 x 400 50/60 Hz	QTD - QDR - QDR2 - Q3D
KIT SCA 3	3 x 400 50/60 Hz	Q3Y-Q3A-Q3I-Q3SF-Q3D

**COOLING SHROUDS**

01890\_B\_DD

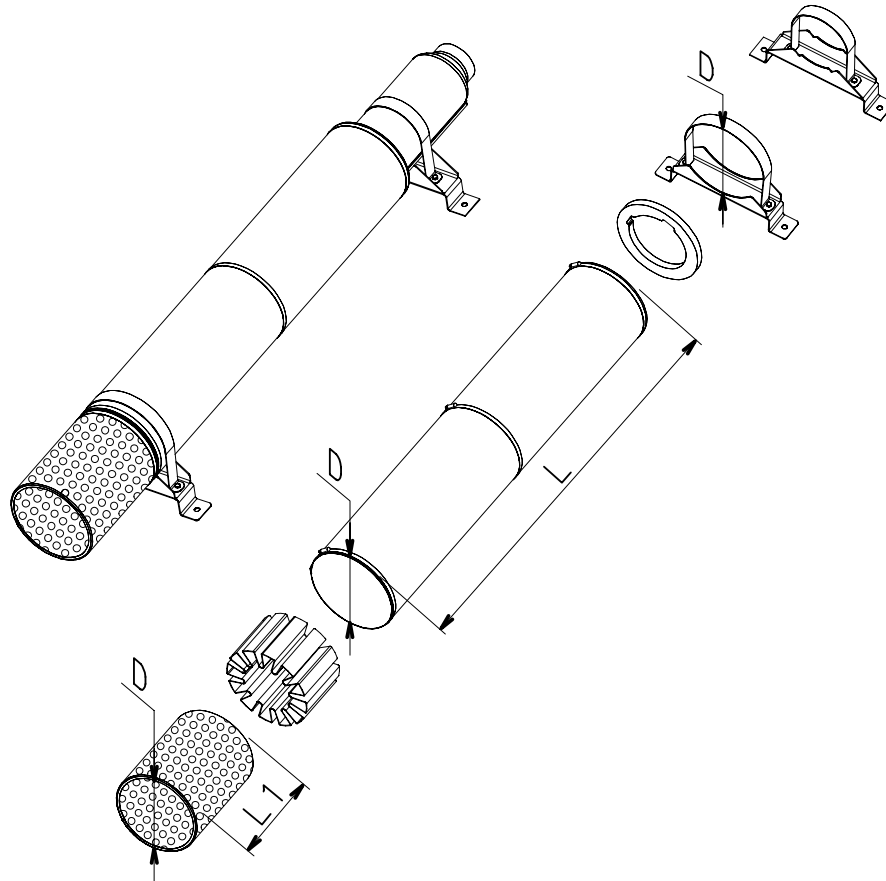

PUMP TYPE	MOTOR TYPE		COOLING SET SHROUD (D x L)	COOLING SET FILTER (D x L1)	COOLING SET BRACKETS (D)
	40S/B	L4C			
1GSL 2GS 4GS 6GS 8GS 12GS	0,37	0,37	D115X500	D115X117	D115/2 - 2PZ
	0,55	0,55			
	0,75	0,75			
	1,1	1,1	D115X800	D115X117	D115 - 2PZ
	1,5	1,5			
	2,2	2,2			
	3	3			
	4	4			
5,5	5,5	D115X1000	D115X117	D115 - 2PZ	
7,5	7,5				
16GS	2,2	2,2	D145X800	D145X158	D145 - 2PZ
	3	3			
	4	4			
	5,5	5,5	D145X1000	D145X158	D145 - 2PZ
	7,5	7,5			

gs\_kit-raf50-en\_b\_ta





# **TECHNICAL APPENDIX**

**SUBMERSIBLE ELECTRIC PUMP INSTALLATION DIAGRAM**

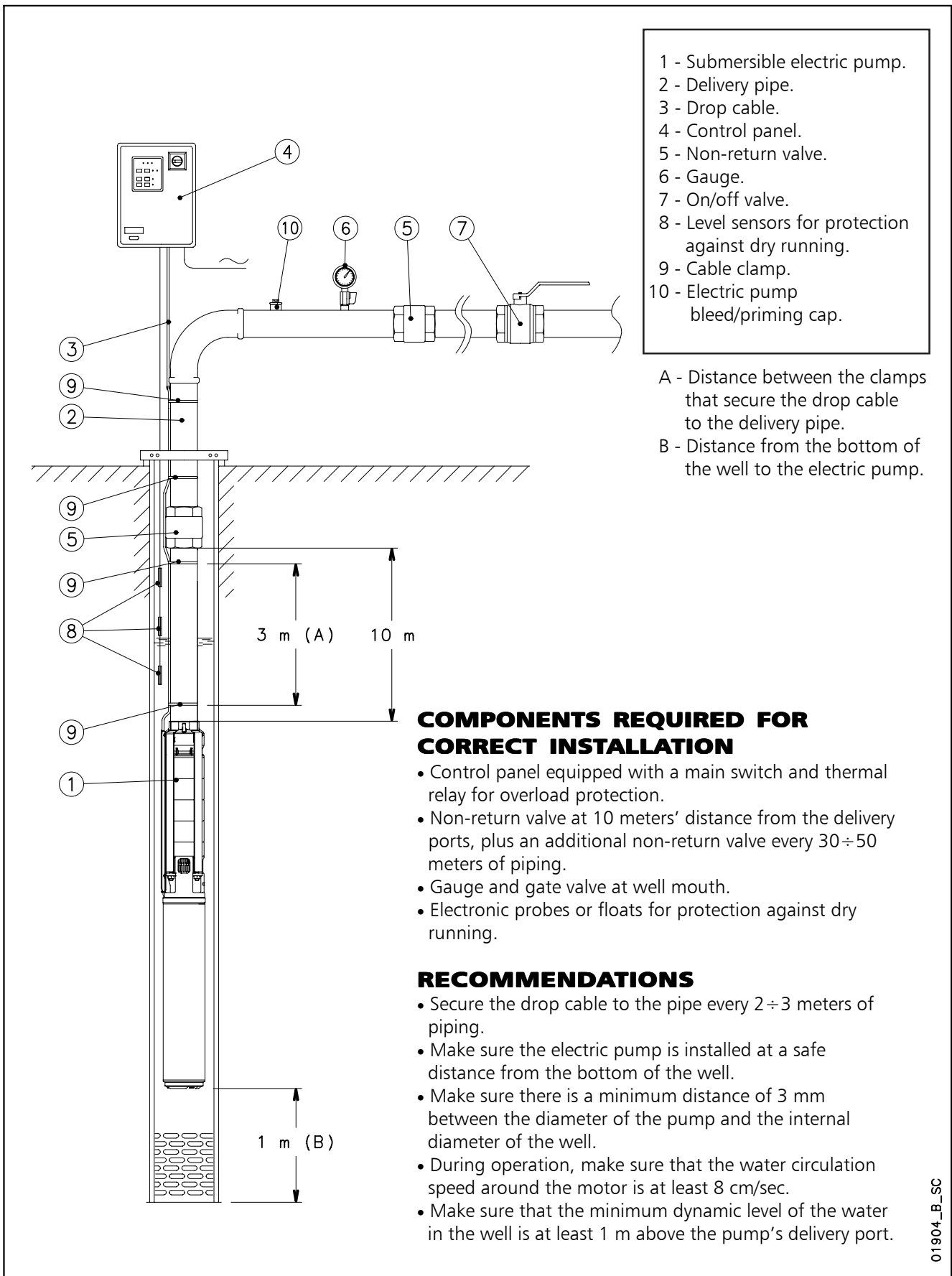

01904\_B\_SC

**EXAMPLE OF INSTALLATION OF A SUBMERSIBLE ELECTRIC PUMP CONTROLLED BY AN INVERTER (HYDROVAR®)**

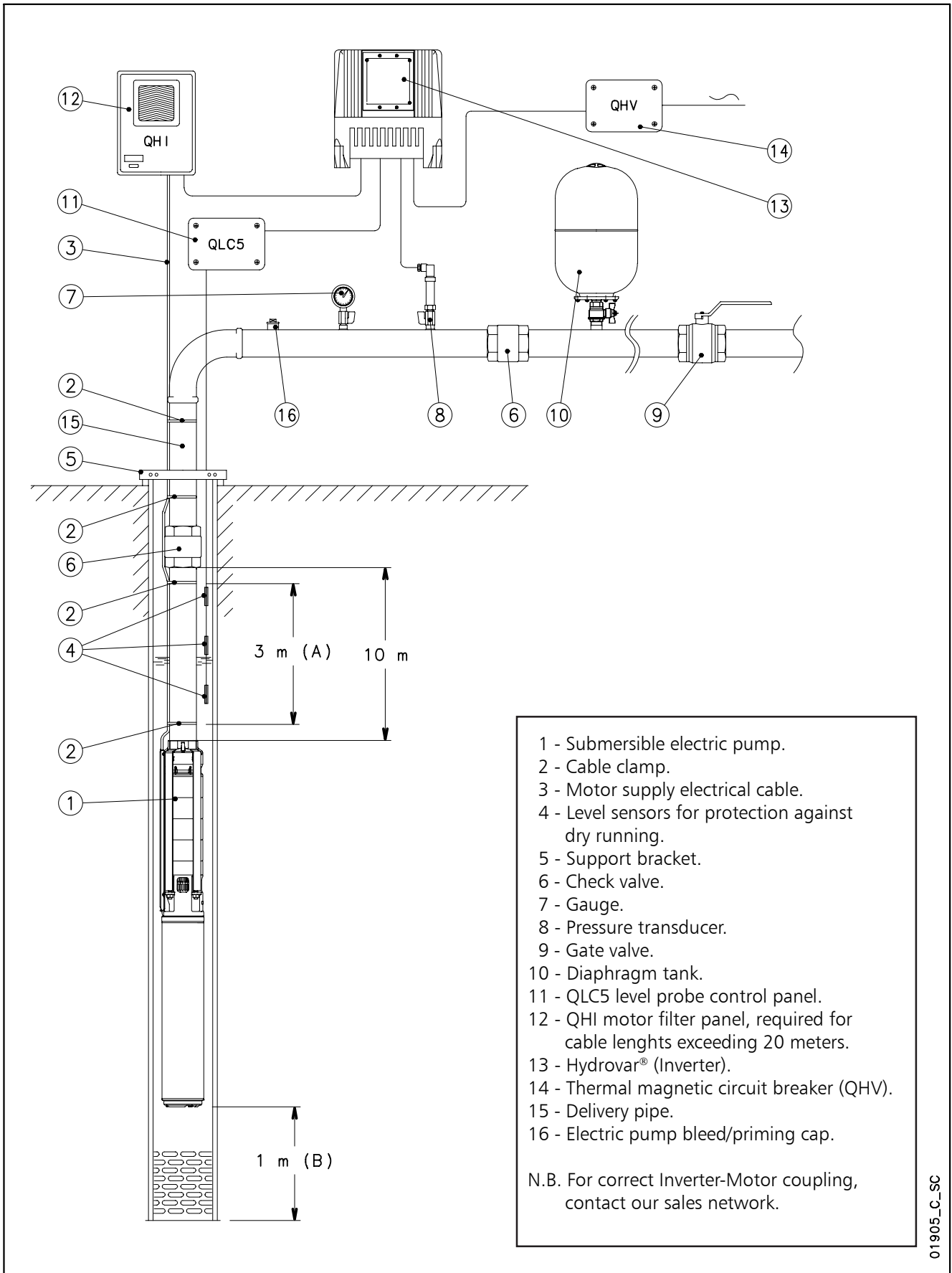

## 40S MOTOR SERIES

TABLE OF POWER REDUCTION COEFFICIENTS WITH INCREASED WATER TEMPERATURE

MOTOR TYPE	RATED POWER kW	TEMPERATURE °C					
		30	35	40	45	50	55
40S	all models	1	1	0,9	0,8	0,7	0,6

EXAMPLE:

40S-derating-50-en\_a\_te

A 2,2 kW 40S motor is to be used in 50°C water.

Motor power at 50 °C = 2,2 x 0,7 = 1,54 kW

## L4C MOTOR SERIES

TABLE OF POWER REDUCTION COEFFICIENTS WITH INCREASED WATER TEMPERATURE

MOTOR TYPE	RATED POWER kW	TEMPERATURE °C					
		30	35	40	45	50	55
L4C	all models	1	1	0,95	0,9	0,85	0,8

EXAMPLE:

L4c-derating-50-en\_b\_te

A 2,2 kW L4C motor is to be used in 50°C water.

Motor power at 50 °C = 2,2 x 0,85 = 1,87 kW

## SELECTING CABLE CROSS-SECTIONS FOR SUBMERSIBLE MOTORS

To select the cross-section of power cables for submersible pumps, consult the tables shown below. In these tables, the maximum lengths of the power cable for each cross-section are shown for each motor and next to the various input voltage ratings.

Therefore, to find the required cable cross-section, simply read off the maximum permitted lengths for each cross-section next to the selected motor and required input voltage.

E.g.:

A 100 m long power cable must be matched with a 230V L4C07M236 motor.

To determine the cross-section of the cable, simply move along the row of the 230V motor until you find the maximum length of 100 m or immediately above it and then read off the corresponding cross-section in that column.

In this case, the 4 mm<sup>2</sup> cable is selected.

N.B.: the tables include specific data (current and power factor) for each motor and voltage rating based on a maximum voltage drop of 4% (HD 384.5), a maximum cable temperature of 90°C, water installation similar to air installation at a temperature of 30°C.

## CABLE TYPES

SECTION mm <sup>2</sup>	THREE CORE FLAT					FOUR CORE FLAT					SINGLE CORE ROUND			FOUR CORE ROUND		
	Hmin mm	Lmin mm	Hmax mm	Lmax mm	Weight kg/km	Hmin mm	Lmin mm	Hmax mm	Lmax mm	Weight kg/km	Dmin mm	Dmax mm	Weight kg/km	Dmin mm	Dmax mm	Weight kg/km
4	8	19,2	9	20,8	250	8	25,2	9	26,8	395	6,5	7,5	92	14	16,1	360
6	8	19,2	9	20,8	325	8	25,2	9	26,8	470	7,4	8	118	15,7	18	475
10	8	19,2	9	20,8	535	8	25,2	9	26,8	710	8,6	10	183	20,9	23,9	836
16	-	-	-	-	-	-	-	-	-	-	9,6	11	251	23,8	27,1	1145
25	-	-	-	-	-	-	-	-	-	-	11	13	362	28,9	32,9	1716
35	-	-	-	-	-	-	-	-	-	-	12,5	14,5	497	-	-	-
50	-	-	-	-	-	-	-	-	-	-	15	17	669	-	-	-
70	-	-	-	-	-	-	-	-	-	-	17,5	19,5	901	-	-	-
95	-	-	-	-	-	-	-	-	-	-	20,5	22,5	1141	-	-	-
120	-	-	-	-	-	-	-	-	-	-	22	24,4	1435	-	-	-
150	-	-	-	-	-	-	-	-	-	-	25,2	28,3	1795	-	-	-
185	-	-	-	-	-	-	-	-	-	-	27,6	31	2156	-	-	-
240	-	-	-	-	-	-	-	-	-	-	30,6	34,5	2760	-	-	-

L-cavi-en\_a\_td

## SCUBA, 60 Hz: SIZING OF ETHYLENE-PROPILENE (EPR) CABLES, DOL (DIRECT ON LINE) STARTING

PUMP TYPE	RATED POWER		RATED VOLTAGE	Cos φ	RATED CURRENT	VOLTAGE DROP	CABLE SECTION: 3 x ...mm <sup>2</sup>									
							mm <sup>2</sup>	1	1,5	2,5	4	6	10	16	25	
							A max	17	23	32	42	54	75	100	127	
SINGLE PHASE	Kw	HP	V		A	%	Maximum lenght in metres									
SC2076	0,75	1	220	0,956	4,47	4		51	77	129	206	309				
			230	0,956	4,47			54	81	135	215	323				
SC2096	0,9	1,2	220	0,966	5,4			42	63	105	169	253	422			
			230	0,966	5,4			44	66	110	176	265	441			
SC2116	1,1	1,5	220	0,981	6,43			35	52	87	140	209	349			
			230	0,981	6,43			36	55	91	146	219	365			
SC4076	0,75	1	220	0,956	4,52			51	76	127	204	305				
			230	0,956	4,52			53	80	133	213	319				
SC4096	0,9	1,2	220	0,965	5,31			43	64	107	172	258	429			
			230	0,965	5,31			45	67	112	180	269	449			
SC4116	1,1	1,5	220	0,983	6,8			33	49	82	132	197	329			
			230	0,983	6,8			34	52	86	138	206	344			

Laying in open air at the temperature of 30 °C, the maximum lead temperature is 80 °C.

Scubam-cavi-60-en\_c\_te

PUMP TYPE	RATED POWER		RATED VOLTAGE	Cos φ	RATED CURRENT	VOLTAGE DROP	CABLE SECTION: 4 x ...mm <sup>2</sup>								
							mm <sup>2</sup>	1	1,5	2,5	4	6	10	16	25
							A max	17	23	32	42	54	75	100	127
THREE PHASE	Kw	HP	V		A	%	Maximum lenght in metres								
SC2076T	0,75	1	220	0,744	2,99	4		128	192	319					
			230	0,744	2,99			134	200	334					
			380	0,744	1,73			381							
			400	0,744	1,73			402							
SC2096T	0,9	1,2	220	0,808	3,52			100	150	250	400				
			230	0,808	3,52			104	157	261	418				
			380	0,808	2,03			299							
			400	0,808	2,03			315							
SC2116T	1,1	1,5	220	0,842	4,1			82	124	206	329				
			230	0,842	4,1			86	129	215	344				
			380	0,842	2,37			246	369						
			400	0,842	2,37			259	388						
SC4076T	0,75	1	220	0,749	3,03			125	188	313					
			230	0,749	3,03			131	196	327					
			380	0,749	1,75			375							
			400	0,749	1,75			394							
SC4096T	0,9	1,2	220	0,804	3,46		102	153	255	409					
			230	0,804	3,46		107	160	267	427					
			380	0,804	2		305								
			400	0,804	2		321								
SC4116T	1,1	1,5	220	0,852	4,3		78	116	194	310					
			230	0,852	4,3		81	122	203	324					
			380	0,852	2,48		232	349							
			400	0,852	2,48		245	367							

Laying in open air at the temperature of 30 °C, the maximum lead temperature is 80 °C.

Scubat-cavi-60-en\_c\_te

## 4OS SINGLE-PHASE, 60 Hz: SIZING OF ETHYLENE-PROPILENE (EPR) CABLES, DOL (DIRECT ON LINE) STARTING

MOTOR TYPE SINGLE-PHASE	RATED POWER		RATED VOLTAGE V	Cos φ	CURRENT AT S.F. A	VOLTAGE DROP %	Cable cross section: 4G x ...mm <sup>2</sup>												
	Kw	HP					mm <sup>2</sup>	1,5	2,5	4	6	10	16	25	35				
							A max	23	32	42	54	75	100	127	158				
												Maximum length in metres							
4OS03M236	0,37	0,5	220	0,99	4,50	4		71	118	191	286								
			230	0,98	4,42														
4OS05M236	0,55	0,8	220	0,99	6,23			51	85	137	206	356							
			230	0,97	6,00														
4OS07M236	0,75	1	220	0,97	7,41			43	73	117	176	304							
			230	0,94	7,36														
4OS11M236	1,1	1,5	220	0,99	9,34			33	56	91	137	237	373						
			230	0,99	9,05														
4OS15M236	1,5	2	220	0,99	12,2			25	42	69	104	181	285	441					
			230	0,97	11,9														
4OS22M236	2,2	3	220	0,93	17,1			17	31	51	78	135	212	324					
			230	0,90	17,1														
4OS03M116	0,37	0,5	110	0,99	9,02			17	29	47	71	123	193	299	418				
			115	0,98	8,86														
4OS05M116	0,55	0,75	110	0,98	12,3			12	21	35	52	91	143	220	307				
			115	0,94	12,3														
4OS07M116	0,75	1	110	0,98	14,5		10	18	29	44	76	120	186	259					
			115	0,95	14,3														
4OS11M116	1,1	1,5	110	0,99	18,1		8	14	23	35	60	96	148	208					
			115	0,98	17,7														

Exposed cable laid at a temperature of 30°C, maximum conductor temperature of 90°C

4osm-b\_cavi-60\_d\_te

### 4OS THREE-PHASE, 60 Hz: SIZING OF ETHYLENE-PROPILENE (EPR) CABLES, DOL (DIRECT ON LINE) STARTING

MOTOR TYPE THREE-PHASE	RATED POWER		RATED VOLTAGE V	Cos φ	CURRENT AT S.F. A	VOLTAGE DROP %	Cable cross section: 4G x ...mm <sup>2</sup>														
	Kw	HP					mm <sup>2</sup>	1,5	2,5	4	6	10	16	25	35						
							A max	23	32	42	54	75	100	127	158						
												Maximum length in metres									
4OS03T236	0,37	0,5	220	0,62	3,17	4		184	305												
			230				0,56	3,31													
4OS05T236	0,55	0,75	220	0,71	4,00			127	212	339											
			230				0,65	4,05													
4OS07T236	0,75	1	220	0,66	5,21			104	174	279	414										
			230				0,59	5,51													
4OS11T236	1,1	1,5	220	0,72	6,53			76	127	204	304										
			230				0,65	6,70													
4OS15T236	1,5	2	220	0,71	8,40			59	99	160	239	407									
			230				0,65	8,73													
4OS22T236	2,2	3	220	0,71	11,6			41	71	115	172	294	454								
			230				0,64	12,5													
4OS30T236	3	4	220	0,79	14,5			29	50	82	124	213	331								
			230				0,72	14,8													
4OS40T236	4	5,5	220	0,85	17,7			21	37	62	94	163	254	386							
			230				0,81	17,4													
4OS55T236	5,5	7,5	220	0,86	24,4			-	33	52	78	133	206	312	428						
			230				0,83	23,8													
4OS75T236	7,5	10	220	0,75	36,8			-	-	29	47	84	133	201	276						
			230				0,68	38,1													
4OS03T386	0,37	0,5	380	0,62	1,83		552														
4OS05T386	0,55	0,75	380	0,71	2,31		382														
4OS07T386	0,75	1	380	0,66	3,01		315	522													
4OS11T386	1,1	1,5	380	0,72	3,77		230	383													
4OS15T386	1,5	2	380	0,71	4,85		180	301	482												
4OS22T386	2,2	3	380	0,71	6,69		129	217	349	519											
4OS30T386	3	4	380	0,79	8,35		92	156	251	376											
4OS40T386	4	5,5	380	0,85	10,2		69	118	191	287	492										
4OS55T386	5,5	7,5	380	0,86	14,1		47	82	135	203	351										
4OS75T386	7,5	10	380	0,75	21,2		32	59	99	150	261	406									

Exposed cable laid at a temperature of 30°C, maximum conductor temperature of 90°C

4ost-b\_cavi-60\_c\_te

## L4C SINGLE-PHASE, 60 Hz: SIZING OF ETHYLENE-PROPILENE (EPR) CABLES, DOL (DIRECT ON LINE) STARTING

MOTOR TYPE	RATED POWER		RATED VOLTAGE	Cos φ	CURRENT AT S.F.	VOLTAGE DROP	Cable cross section: 4G x ...mm <sup>2</sup>									
							mm <sup>2</sup>	1,5	2,5	4	6	10	16	25	35	
							A max	23	32	42	54	75	100	127	158	
<b>SINGLE-PHASE</b>	<b>Kw</b>	<b>HP</b>	<b>V</b>		<b>A</b>	<b>%</b>	<b>Maximum length in metres</b>									
L4C03M236	0,37	0,5	220	0,93	5,3	4		63	106	171	256	440				
			230	0,89	5,5											
L4C05M236	0,55	0,75	220	0,89	7,0			49,6	83,4	135	202	346				
			230	0,84	7,4											
L4C07M236	0,75	1	220	0,93	8,5			40	68	110	165	284	443			
			230	0,89	8,9											
L4C11M236	1,1	1,5	220	0,88	12,2			27,5	47,2	77	116	199	312			
			230	0,84	12,7											
L4C15M236	1,5	2	220	0,98	13,1			23	39	65	98	170	267	412		
			230	0,97	12,8											
L4C22M236	2,2	3	220	0,96	17,6			16,3	29	48,1	73,2	127	201	309		
			230	0,96	17,1											
L4C40M236	4,0	5,5	220	0,93	30,7			-	15	26	41	73	116	179	249	
			230	0,92	29,7											
L4C03M116	0,37	0,5	110	0,93	10,6			15,2	26	42,3	63,6	110	172	262	364	
			115	0,89	11,0											
L4C05M116	0,55	0,75	110	0,89	14,0			12	20	33	50	86	134	205	282	
			115	0,84	14,8											
L4C07M116	0,75	1	110	0,93	17,0		9,03	16,1	26,6	40,5	70,2	110	168	232		
			115	0,89	17,8											

Exposed cable laid at a temperature of 30°C, maximum conductor temperature of 90°C

l4cm-cavi-60-en\_b\_te



## L4C THREE-PHASE, 60 Hz: SIZING OF ETHYLENE-PROPILENE (EPR) CABLES, DOL (DIRECT ON LINE) STARTING

MOTOR TYPE	RATED POWER		RATED VOLTAGE	Cos φ	CURRENT AT S.F.	VOLTAGE DROP	Cable cross section: 4G x ...mm <sup>2</sup>											
							mm <sup>2</sup>	1,5	2,5	4	6	10	16	25	35			
							A max	23	32	42	54	75	100	127	158			
THREE-PHASE	Kw	HP	V		A	%	Maximum length in metres											
L4C03T236	0,37	0,5	220	0,78	3,5	4		131	218									
			230	0,76	3,8													
L4C05T236	0,55	0,75	220	0,82	4,6			95,8	160	257								
			230	0,77	4,8													
L4C07T236	0,75	1	220	0,74	5,3			92,9	155	249	371							
			230	0,72	5,6													
L4C11T236	1,1	1,5	220	0,75	7,5			63	106	171	255							
			230	0,72	7,8													
L4C15T236	1,5	2	220	0,71	9,4			52,2	88,4	143	213	363						
			230	0,68	9,8													
L4C22T236	2,2	3	220	0,77	11,5			39,5	67,7	110	165	282	438					
			230	0,75	12													
L4C30T236	3	4	220	0,73	16,5			27,4	48,4	79,8	121	207	321					
			230	0,7	17,3													
L4C40T236	4	5,5	220	0,8	18,8			20,6	36,9	61,3	93,2	161	252	380				
			230	0,78	19,2													
L4C55T236	5,5	7,5	220	0,8	25,4			-	25,6	43,6	67,3	118	185	280	385			
			230	0,78	26													
L4C03T386	0,37	0,5	380	0,76	2,3			359										
L4C05T386	0,55	0,75	380	0,77	2,9			281										
L4C07T386	0,75	1	380	0,72	3,4		255	425										
L4C11T386	1,1	1,5	380	0,72	4,7		184	306										
L4C15T386	1,5	2	380	0,68	5,9		154	257	413									
L4C22T386	2,2	3	380	0,75	7,2		114	191	307	458								
L4C30T386	3	4	380	0,73	9,5		86,8	147	238	355								
L4C40T386	4	5,5	380	0,78	11,6		65,3	112	181	272	466							
L4C55T386	5,5	7,5	380	0,78	15,7		45,8	80,3	132	199	343							
L4C75T386	7,5	10	380	0,8	20		-	59,3	98,9	151	261	408						

Exposed cable laid at a temperature of 30°C, maximum conductor temperature of 90°C

l4c-cavi-60-en\_b\_te

## SPLICE BETWEEN DROP CABLE AND MOTOR CABLE

MOTOR TYPE	POWER kW	TYPE OF JOINT	FOUR-CORE DROP CABLE - SECTION (mm <sup>2</sup> )																
			1,5	2,5	4	6	10	16	25	35	50	70	95	120	150	185	240	300	
4OS L4C	0,37 - 7,5	Resin-filled method	GR2	GR2	GR2 GR6	GR2 GR6	GR2 GR6	GR6 GR7	GR6 GR7	GR7 GR5	GR5	GR5	GR5	-	-	-	-	-	
		Heat-shrink method	GT1	GT1	GT2	GT2	GT3	GT4	GT5	GT6	-	-	-	-	-	-	-	-	-
		Tape method	Self-vulcanizing tape + self-vulcanizing sealing putty and PVC tape (1)																
L6C L6W	4 - 37	Resin-filled method	GR2	GR2	GR2 GR6	GR2 GR6	GR2 GR6	GR6 GR7	GR6 GR7	GR7 GR5	GR5	GR5	GR5	-	-	-	-	-	
		Heat-shrink method	GT1	GT1	GT2	GT2	GT3	GT4	GT5	GT6	-	-	-	-	-	-	-	-	-
		Tape method	Self-vulcanizing tape + self-vulcanizing sealing putty and PVC tape (1)																

MOTOR TYPE	POWER kW	TYPE OF JOINT	THREE-CORE DROP CABLE - SECTION (mm <sup>2</sup> )																
			1,5	2,5	4	6	10	16	25	35	50	70	95	120	150	185	240	300	
L6C L6W	4 - 37	Resin-filled method	GR2	GR2	GR2 GR6	GR2 GR6	GR2 GR6	GR6 GR7	GR6 GR7	GR7 GR5	GR5	GR5	GR5	-	-	-	-	-	
		Heat-shrink method	GT1	GT1	GT2	GT2	GT3	GT4	GT5	GT6	-	-	-	-	-	-	-	-	-
		Tape method	Self-vulcanizing tape + PVC tape																

MOTOR TYPE	POWER kW	TYPE OF JOINT	SINGLE-CORE DROP CABLE - SECTION (mm <sup>2</sup> )																
			1,5	2,5	4	6	10	16	25	35	50	70	95	120	150	185	240	300	
L8W L10W L12W	30 - 300	Resin-filled method	-	GR1	GR1	GR1	GR1	GR1	GR1 GR3	GR1 GR3	GR1 GR3	GR3 GR4	GR3 GR4	GR3 GR4	GR3 GR4	GR3 GR4	GR4	GR4	
		Heat-shrink method	-	-	-	-	-	-	-	-	-	-	-	-	-	-	-	-	-
		Tape method	Self-vulcanizing tape + PVC tape																

(1) Use self-vulcanizing sealing putty to fill in the gaps between the three-conductor cable and the ground cable in the area covered by the final layer of tape, to restore continuity to the protective sheath.

L-giunzioni-en\_c\_te

## CALCULATING THE SPEED OF THE FLUID THAT FLOWS AROUND A SUBMERGED MOTOR AND SIZING OF THE COOLING SLEEVE

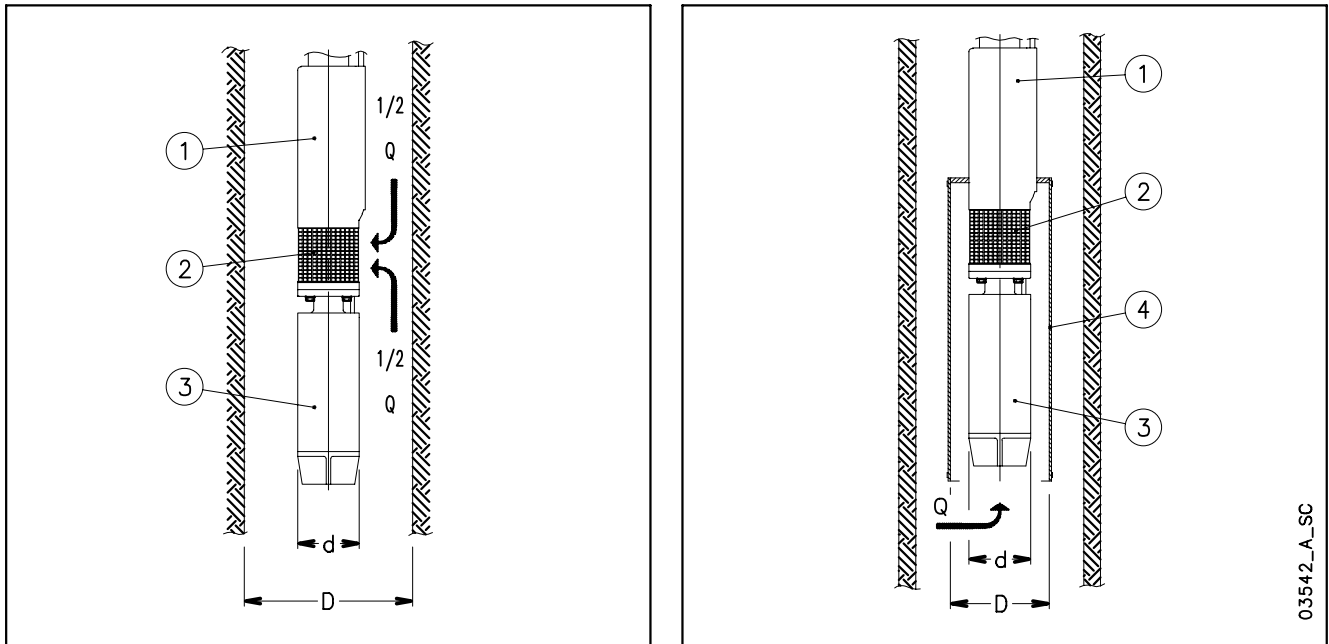

The following formula is used to verify whether the speed of the fluid that flows around the motor of a submersible pump is high enough to guarantee the proper cooling of the motor:

$$v = \frac{\frac{Q}{2}}{\pi \cdot \left( \frac{D^2}{4} - \frac{d^2}{4} \right)}$$

Where: Q in [m<sup>3</sup>/s] is the operating flow rate of the electric pump; only half of this flow is taken into account, because the fluid which is sucked into the area of the filter (2), comes from the motor side (3) as well as from the pump side (1);  
D in [m] corresponds to the diameter of the well;  
d in [m] corresponds to the diameter of the motor (3);  
v in [m/s] is the calculated speed of the fluid that flows around the motor.

Now, compare the speed thus calculated (v) with the minimum speed required for correct cooling of the motor (v<sub>m</sub>): if v ≥ v<sub>m</sub> it means that the motor is properly cooled, if v < v<sub>m</sub> will be necessary to mount a cooling sleeve (4).

### Example:

An electric pump OZ630/12 (motor diameter d = 0.144 m) operates in an 8" well (well diameter D = 0.203 m) with flow rate Q = 20 m<sup>3</sup>/h = 0.0055 m<sup>3</sup>/s.

Speed of fluid v = (0.0055/2) / {π·[(0.203)<sup>2</sup>/4 – (0.144)<sup>2</sup>/4]} = 0.17 m/s.

The minimum speed required for proper motor cooling is v<sub>m</sub> = 0.20 m/s.

Because v < v<sub>m</sub>, it will be necessary to mount a cooling sleeve.

The following formula is used to determine the maximum diameter of a cooling sleeve to be mounted on a submersible motor:

$$D = \sqrt{4 \cdot \left( \frac{Q}{v \cdot \pi} + \frac{d^2}{4} \right)}$$

Where: Q in [m<sup>3</sup>/s] is the operating flow rate of the electric pump; the entire flow is taken into account because the fluid comes from the motor side (3) only;

D in [m] corresponds to the diameter of the cooling sleeve (4);

d in [m] corresponds to the diameter of the motors(3);

v<sub>m</sub> in [m/s] is the minimum speed of the fluid that flows around the motor.

If the electric pump operates at different flow rate, the minimum flow rate must be taken into account for calculating the diameter of the cooling sleeve.

### Example:

A motor coupled to the electric pump OZ615/24 (motor diameter d = 0.144 m), which operates with flow rate

Q = 15 m<sup>3</sup>/h = 0.0042 m<sup>3</sup>/s, requires a minimum speed of the fluid of v<sub>m</sub> = 0.20 m/s.

Cooling sleeve diameter D = {4·[(0.0042/(0.2·π)+(0.144)<sup>2</sup>/4]}<sup>0.5</sup> = 0.217 m.

## ASYNCHRONOUS MOTOR STARTING SYSTEMS

### Direct

Suitable for low-power motors.

The starting current ( $I_s$ ) is much higher than the rated current ( $I_n$ ).

$$\text{Starting current } I_s = I_n \times 4 \div 8$$

$$\text{Starting torque } T_s = T_n \times 2 \div 3$$

### Indirect

#### • Star/Delta

The starting current ( $I_s$ ) is three times less than the direct starting current.

$$\text{Starting current } I_s = I_n \times 1.3 \div 2.7$$

$$\text{Starting torque } T_s = T_n \times 0.7 \div 1$$

In the star to delta changeover phase (approx. 70 ms) the motor is not supplied and tends to reduce its rotation speed.

In the case of submersible electric pumps with power above 10 HP, the modest mass of the rotor causes a slowdown at changeover, so that the initial Star supply phase is rendered partially useless.

In such cases we recommend using impedance panels or an autotransformer.

#### • Impedances

The motor is started with a voltage which is lower than the rated one, and which is obtained by means of impedances.

The Lowara panels use impedances which cut down to 70% the starting voltage.

The switch to the rated voltage takes place without any interruptions of the power supply.

$$\text{Rated voltage } U_n = 400 \text{ V}$$

$$\text{Starting voltage } U_s = U_n \times 0,7 = 280 \text{ V}$$

Starting current

$$I_s = I_n \times 4 \div 8 \times \left( \frac{U_s}{U_n} \right) = I_n \times 3 \div 6$$

Starting torque

$$T_s = T_n \times 2 \div 3 \times \left( \frac{U_s}{U_n} \right)^2 = T_n \times 1 \div 1,5$$

### Autotransformer

The pump is started with a voltage which is lower than the rated one.

The Lowara panels use an autotransformer with a voltage that is 70% the value of the line voltage.

The switch to the rated voltage occurs without any interruptions of the power supply.

$$\text{Rated voltage } U_n = 400 \text{ V}$$

Starting current

$$I_s = I_n \times 4 \div 8 \times \left( \frac{U_s}{U_n} \right) = I_n \times 3 \div 6$$

Starting torque

$$T_s = T_n \times 2 \div 3 \times \left( \frac{U_s}{U_n} \right)^2 = T_n \times 1 \div 1,5$$

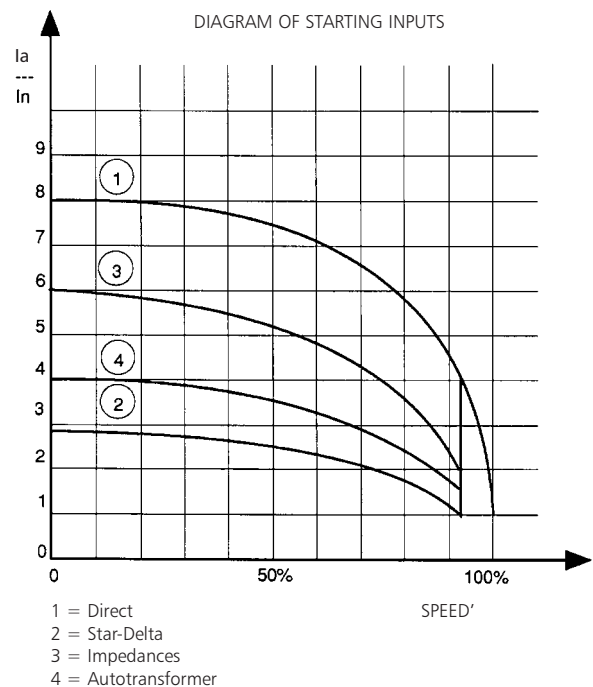

## WATER REQUIREMENTS IN CIVIL USERS

Determination of the water requirement depends on the type of users and contemporaneity factor. The calculation may be subject to regulations, standards or customs that may vary from country to country. The calculation method shown below is an example based on practical experience, designed to provide a reference value and not a substitute for detailed analytical calculation.

### Water requirements in condominiums

The **consumption table** shows the maximum values for each delivery point, depending on the plumbing amenities.

### MAXIMUM CONSUMPTION FOR EACH DELIVERY POINT

TYPE	CONSUMPTION (l/min)
Sink	9
Dishwasher	10
Washing machine	12
Shower	12
Bathtub	15
Washbasin	6
Bidet	6
Flush tank WC	6
Controlled flushing system WC	90

G-at-cm\_a\_th

The **sum of the water consumption values** of each delivery point determines the maximum theoretical requirement, which must be reduced according to the **contemporaneity coefficient**, because in actual fact the delivery points are never used all together.

$f = \frac{1}{\sqrt{(0,857 \times Nr \times Na)}}$	Coefficient for apartments with one bathroom and flush tank WC
$f = \frac{1}{\sqrt{(0,857 \times Nr \times Na)}}$	Coefficient for apartments with one bathroom and controlled flushing system WC
$f = \frac{1,03}{\sqrt{(0,545 \times Nr \times Na)}}$	Coefficient for apartments with two bathrooms and flush tank WC
$f = \frac{0,8}{\sqrt{(0,727 \times Nr \times Na)}}$	Coefficient for apartments with two bathrooms and controlled flushing system WC
f= coefficient; Nr= number of delivery points; Na= number of apartments	

The **table of water requirements in civil users** shows the maximum contemporaneity flow-rate values based on the **number of apartments** and the type of WC for apartments with one bathroom and two bathrooms. As regards apartments with one bathroom, 7 drawing points have been taken into consideration, while 11 points have been considered for apartments with two bathrooms. If the number of drawing points or apartments is different, use the formulas to **calculate** the requirement.

## TABLE OF WATER REQUIREMENTS IN CIVIL USERS

NUMBER OF APARTMENTS	WITH FLUSH TANK WC		WITH CONTROLLED FLUSHING SYSTEM WC	
	1	2	1	2
	FLOW RATE (l/min)			
1	32	40	60	79
2	45	56	85	111
3	55	68	105	136
4	63	79	121	157
5	71	88	135	176
6	78	97	148	193
7	84	105	160	208
8	90	112	171	223
9	95	119	181	236
10	100	125	191	249
11	105	131	200	261
12	110	137	209	273
13	114	143	218	284
14	119	148	226	295
15	123	153	234	305
16	127	158	242	315
17	131	163	249	325
18	134	168	256	334
19	138	172	263	343
20	142	177	270	352
21	145	181	277	361
22	149	185	283	369
23	152	190	290	378
24	155	194	296	386
25	158	198	302	394
26	162	202	308	401
27	165	205	314	409
28	168	209	320	417
29	171	213	325	424
30	174	217	331	431
35	187	234	357	466
40	200	250	382	498
45	213	265	405	528
50	224	280	427	557
55	235	293	448	584
60	245	306	468	610
65	255	319	487	635
70	265	331	506	659
75	274	342	523	682
80	283	354	540	704
85	292	364	557	726
90	301	375	573	747
95	309	385	589	767
100	317	395	604	787
120	347	433	662	863
140	375	468	715	932
160	401	500	764	996
180	425	530	811	1056
200	448	559	854	1114

For seaside resorts, a flow rate increased by at least 20% must be considered.

G-at-fi\_a\_th

## WATER REQUIREMENTS FOR COMMUNITY BUILDINGS

The requirements of buildings intended for specific uses, such as **offices, residential units, hotels, department stores, nursing homes** and so on, are different from those of condominiums, and both their global daily water consumption and the maximum contemporaneity flow rate are usually greater. The **diagram of water requirements for community buildings** shows the maximum contemporaneity flow rate of some types of communities, for guidance.

These requirements must be determined case by case with the utmost accuracy, using analytical calculation methods, according to particular needs and local provisions.

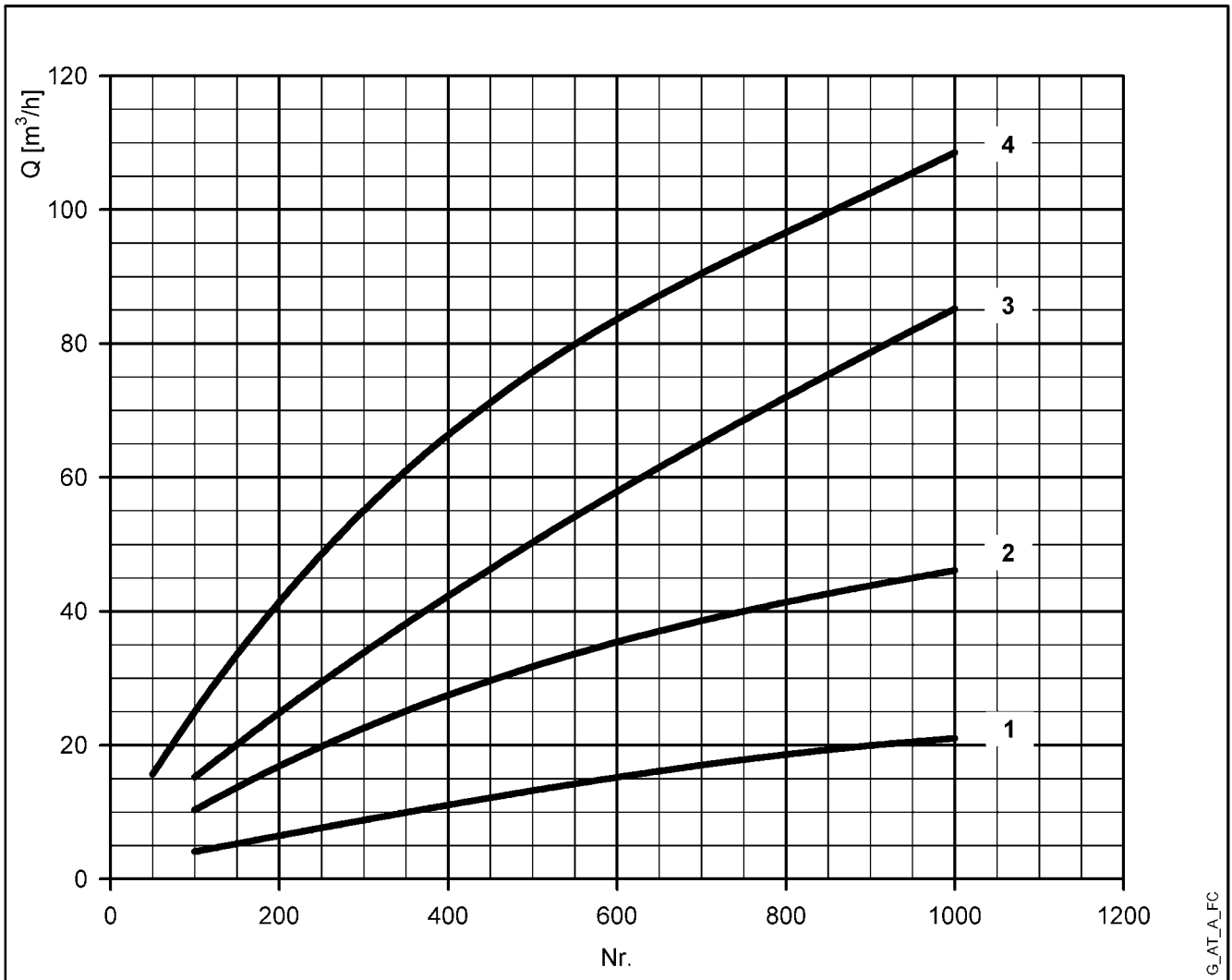

For seaside resorts, the flow rate must be increased by at least 20%.

- 1 = Offices (N. of people)
- 2 = Department stores (N. of people)
- 3 = Nursing homes (N. of beds)
- 4 = Hotels, residences (N. of beds)

## NPSH

The minimum operating values that can be reached at the pump suction end are limited by the onset of cavitation.

Cavitation is the formation of vapour-filled cavities within liquids where the pressure is locally reduced to a critical value, or where the local pressure is equal to, or just below the vapour pressure of the liquid.

The vapour-filled cavities flow with the current and when they reach a higher pressure area the vapour contained in the cavities condenses. The cavities collide, generating pressure waves that are transmitted to the walls. These, being subjected to stress cycles, gradually become deformed and yield due to fatigue. This phenomenon, characterized by a metallic noise produced by the hammering on the pipe walls, is called incipient cavitation.

The damage caused by cavitation may be magnified by electrochemical corrosion and a local rise in temperature due to the plastic deformation of the walls. The materials that offer the highest resistance to heat and corrosion are alloy steels, especially austenitic steel. The conditions that trigger cavitation may be assessed by calculating the total net suction head, referred to in technical literature with the acronym NPSH (Net Positive Suction Head).

The NPSH represents the total energy (expressed in m.) of the liquid measured at suction under conditions of incipient cavitation, excluding the vapour pressure (expressed in m.) that the liquid has at the pump inlet.

To find the static height  $h_z$  at which to install the machine under safe conditions, the following formula must be verified:

$$h_p + h_z \geq (\text{NPSH}_r + 0.5) + h_f + h_{pv} \quad \textcircled{1}$$

where:

- $h_p$**  is the absolute pressure applied to the free liquid surface in the suction tank, expressed in m. of liquid;  $h_p$  is the quotient between the barometric pressure and the specific weight of the liquid.
- $h_z$**  is the suction lift between the pump axis and the free liquid surface in the suction tank, expressed in m.;  $h_z$  is negative when the liquid level is lower than the pump axis.
- $h_f$**  is the flow resistance in the suction line and its accessories, such as: fittings, foot valve, gate valve, elbows, etc.
- $h_{pv}$**  is the vapour pressure of the liquid at the operating temperature, expressed in m. of liquid.  $h_{pv}$  is the quotient between the Pv vapour pressure and the liquid's specific weight.
- 0,5** is the safety factor.

The maximum possible suction head for installation depends on the value of the atmospheric pressure (i.e. the elevation above sea level at which the pump is installed) and the temperature of the liquid.

To help the user, with reference to water temperature (4° C) and to the elevation above sea level, the following tables show the drop in hydraulic pressure head in relation to the elevation above sea level, and the suction loss in relation to temperature.

<b>Water temperature (°C)</b>	20	40	60	80	90	110	120
<b>Suction loss (m)</b>	0,2	0,7	2,0	5,0	7,4	15,4	21,5

<b>Elevation above sea level (m)</b>	500	1000	1500	2000	2500	3000
<b>Suction loss (m)</b>	0,55	1,1	1,65	2,2	2,75	3,3

Friction loss is shown in the tables at pages 82-83 of this catalogue. To reduce it to a minimum, especially in cases of high suction head (over 4-5 m.) or within the operating limits with high flow rates, we recommend using a suction line having a larger diameter than that of the pump's suction port. It is always a good idea to position the pump as close as possible to the liquid to be pumped.

Make the following calculation:

Liquid: water at ~15°C  $\gamma = 1 \text{ kg/dm}^3$

Flow rate required: 30 m<sup>3</sup>/h

Head for required delivery: 43 m.

Suction lift: 3,5 m.

The selection is an FHE 40-200/75 pump whose NPSH required value is, at 30 m<sup>3</sup>/h, di 2,5 m.

For water at 15 °C

$$h_p = P_a / \gamma = 10,33\text{m}, h_{pv} = P_v / \gamma = 0,174\text{m} (0,01701 \text{ bar})$$

The  $H_f$  flow resistance in the suction line with foot valves is ~ 1,2 m.

By substituting the parameters in formula  $\textcircled{1}$  with the numeric values above, we have:

$$10,33 + (-3,5) \geq (2,5 + 0,5) + 1,2 + 0,17$$

from which we have: 6,8 > 4,4

The relation is therefore verified.



## TECHNICAL APPENDIX VAPOUR PRESSURE PS VAPOUR PRESSURE AND $\rho$ DENSITY OF WATER TABLE

t °C	T K	ps bar	$\rho$ kg/dm <sup>3</sup>	t °C	T K	ps bar	$\rho$ kg/dm <sup>3</sup>	t °C	T K	ps bar	$\rho$ kg/dm <sup>3</sup>
0	273,15	0,00611	0,9998	55	328,15	0,15741	0,9857	120	393,15	1,9854	0,9429
1	274,15	0,00657	0,9999	56	329,15	0,16511	0,9852	122	395,15	2,1145	0,9412
2	275,15	0,00706	0,9999	57	330,15	0,17313	0,9846	124	397,15	2,2504	0,9396
3	276,15	0,00758	0,9999	58	331,15	0,18147	0,9842	126	399,15	2,3933	0,9379
4	277,15	0,00813	1,0000	59	332,15	0,19016	0,9837	128	401,15	2,5435	0,9362
5	278,15	0,00872	1,0000	60	333,15	0,1992	0,9832	130	403,15	2,7013	0,9346
6	279,15	0,00935	1,0000	61	334,15	0,2086	0,9826	132	405,15	2,867	0,9328
7	280,15	0,01001	0,9999	62	335,15	0,2184	0,9821	134	407,15	3,041	0,9311
8	281,15	0,01072	0,9999	63	336,15	0,2286	0,9816	136	409,15	3,223	0,9294
9	282,15	0,01147	0,9998	64	337,15	0,2391	0,9811	138	411,15	3,414	0,9276
10	283,15	0,01227	0,9997	65	338,15	0,2501	0,9805	140	413,15	3,614	0,9258
11	284,15	0,01312	0,9997	66	339,15	0,2615	0,9799	145	418,15	4,155	0,9214
12	285,15	0,01401	0,9996	67	340,15	0,2733	0,9793	155	428,15	5,433	0,9121
13	286,15	0,01497	0,9994	68	341,15	0,2856	0,9788	160	433,15	6,181	0,9073
14	287,15	0,01597	0,9993	69	342,15	0,2984	0,9782	165	438,15	7,008	0,9024
15	288,15	0,01704	0,9992	70	343,15	0,3116	0,9777	170	443,15	7,920	0,8973
16	289,15	0,01817	0,9990	71	344,15	0,3253	0,9770	175	448,15	8,924	0,8921
17	290,15	0,01936	0,9988	72	345,15	0,3396	0,9765	180	453,15	10,027	0,8869
18	291,15	0,02062	0,9987	73	346,15	0,3543	0,9760	185	458,15	11,233	0,8815
19	292,15	0,02196	0,9985	74	347,15	0,3696	0,9753	190	463,15	12,551	0,8760
20	293,15	0,02337	0,9983	75	348,15	0,3855	0,9748	195	468,15	13,987	0,8704
21	294,15	0,24850	0,9981	76	349,15	0,4019	0,9741	200	473,15	15,550	0,8647
22	295,15	0,02642	0,9978	77	350,15	0,4189	0,9735	205	478,15	17,243	0,8588
23	296,15	0,02808	0,9976	78	351,15	0,4365	0,9729	210	483,15	19,077	0,8528
24	297,15	0,02982	0,9974	79	352,15	0,4547	0,9723	215	488,15	21,060	0,8467
25	298,15	0,03166	0,9971	80	353,15	0,4736	0,9716	220	493,15	23,198	0,8403
26	299,15	0,03360	0,9968	81	354,15	0,4931	0,9710	225	498,15	25,501	0,8339
27	300,15	0,03564	0,9966	82	355,15	0,5133	0,9704	230	503,15	27,976	0,8273
28	301,15	0,03778	0,9963	83	356,15	0,5342	0,9697	235	508,15	30,632	0,8205
29	302,15	0,04004	0,9960	84	357,15	0,5557	0,9691	240	513,15	33,478	0,8136
30	303,15	0,04241	0,9957	85	358,15	0,5780	0,9684	245	518,15	36,523	0,8065
31	304,15	0,04491	0,9954	86	359,15	0,6011	0,9678	250	523,15	39,776	0,7992
32	305,15	0,04753	0,9951	87	360,15	0,6249	0,9671	255	528,15	43,246	0,7916
33	306,15	0,05029	0,9947	88	361,15	0,6495	0,9665	260	533,15	46,943	0,7839
34	307,15	0,05318	0,9944	89	362,15	0,6749	0,9658	265	538,15	50,877	0,7759
35	308,15	0,05622	0,9940	90	363,15	0,7011	0,9652	270	543,15	55,058	0,7678
36	309,15	0,05940	0,9937	91	364,15	0,7281	0,9644	275	548,15	59,496	0,7593
37	310,15	0,06274	0,9933	92	365,15	0,7561	0,9638	280	553,15	64,202	0,7505
38	311,15	0,06624	0,9930	93	366,15	0,7849	0,9630	285	558,15	69,186	0,7415
39	312,15	0,06991	0,9927	94	367,15	0,8146	0,9624	290	563,15	74,461	0,7321
40	313,15	0,07375	0,9923	95	368,15	0,8453	0,9616	295	568,15	80,037	0,7223
41	314,15	0,07777	0,9919	96	369,15	0,8769	0,9610	300	573,15	85,927	0,7122
42	315,15	0,08198	0,9915	97	370,15	0,9094	0,9602	305	578,15	92,144	0,7017
43	316,15	0,09639	0,9911	98	371,15	0,9430	0,9596	310	583,15	98,70	0,6906
44	317,15	0,09100	0,9907	99	372,15	0,9776	0,9586	315	588,15	105,61	0,6791
45	318,15	0,09582	0,9902	100	373,15	1,0133	0,9581	320	593,15	112,89	0,6669
46	319,15	0,10086	0,9898	102	375,15	1,0878	0,9567	325	598,15	120,56	0,6541
47	320,15	0,10612	0,9894	104	377,15	1,1668	0,9552	330	603,15	128,63	0,6404
48	321,15	0,11162	0,9889	106	379,15	1,2504	0,9537	340	613,15	146,05	0,6102
49	322,15	0,11736	0,9884	108	381,15	1,3390	0,9522	350	623,15	165,35	0,5743
50	323,15	0,12335	0,9880	110	383,15	1,4327	0,9507	360	633,15	186,75	0,5275
51	324,15	0,12961	0,9876	112	385,15	1,5316	0,9491	370	643,15	210,54	0,4518
52	325,15	0,13613	0,9871	114	387,15	1,6362	0,9476	374,15	647,30	221,20	0,3154
53	326,15	0,14293	0,9862	116	389,15	1,7465	0,9460				
54	327,15	0,15002	0,9862	118	391,15	1,8628	0,9445				

G-at\_nps\_h\_a\_sc



## FLOW RESISTANCE

### TABLE OF FLOW RESISTANCE IN BENDS, VALVES AND GATES

The flow resistance is calculated using the equivalent pipeline length method according to the table below:

ACCESSORY TYPE	DN											
	25	32	40	50	65	80	100	125	150	200	250	300
	Equivalent pipeline length (m)											
45° bend	0,2	0,2	0,4	0,4	0,6	0,6	0,9	1,1	1,5	1,9	2,4	2,8
90° bend	0,4	0,6	0,9	1,1	1,3	1,5	2,1	2,6	3,0	3,9	4,7	5,8
90° smooth bend	0,4	0,4	0,4	0,6	0,9	1,1	1,3	1,7	1,9	2,8	3,4	3,9
Union tee or cross	1,1	1,3	1,7	2,1	2,6	3,2	4,3	5,3	6,4	7,5	10,7	12,8
Gate	-	-	-	0,2	0,2	0,2	0,4	0,4	0,6	0,9	1,1	1,3
Non return valve	1,1	1,5	1,9	2,4	3,0	3,4	4,7	5,9	7,4	9,6	11,8	13,9

G-a-pcv\_a\_th

The table is valid for the Hazen Williams coefficient  $C = 100$  (cast iron pipework). For steel pipework, multiply the values by 1.41. For stainless steel, copper and coated cast iron pipework, multiply the values by 1.85.

When the **equivalent pipeline length** has been determined, the flow resistance is obtained from the table of flow resistance.

The values given are guideline values which are bound to vary slightly according to the model, especially for gate valves and non-return valves, for which it is a good idea to check the values supplied by the manufacturers.

## VOLUMETRIC CAPACITY

Litres per minute l/min	Cubic metres per hour m <sup>3</sup> /h	Cubic feet per hour ft <sup>3</sup> /h	Cubic feet per minute ft <sup>3</sup> /min	Imp. gal. per minute Imp. gal./min	US gal. per minute Us gal./min
<b>1,000</b>	0,0600	2,1189	0,0353	0,2200	0,2642
16,6667	<b>1,0000</b>	35,3147	0,5886	3,6662	4,4029
0,4719	0,0283	<b>1,0000</b>	0,0167	0,1038	0,1247
28,3168	1,6990	60,0000	<b>1,0000</b>	6,2288	7,4805
4,5461	0,2728	9,6326	0,1605	<b>1,0000</b>	1,2009
3,7854	0,2271	8,0208	0,1337	0,8327	<b>1,0000</b>

## PRESSURE AND HEAD

Newton per square metre N/m <sup>2</sup>	kilo Pascal kPa	bar bar	Pound force per square inch psi	metre of water m H <sub>2</sub> O	millimetre of mercury mm Hg
<b>1,0000</b>	0,0010	1 x 10 <sup>-5</sup>	1.45 x 10 <sup>-4</sup>	1.02 x 10 <sup>-4</sup>	0,0075
1000,0000	<b>1,0000</b>	0,0100	0,1450	0,1020	7,5006
1 x 10 <sup>5</sup>	100,0000	<b>1,0000</b>	14,5038	10,1972	750,0638
6894,7570	6,8948	0,0689	<b>1,0000</b>	0,7031	51,7151
9806,6500	9,8067	0,0981	1,4223	<b>1,0000</b>	73,5561
133,3220	0,1333	0,0013	0,0193	0,0136	<b>1,0000</b>

## LENGHT

millimetre mm	centimetre cm	metre m	inch in	foot ft	yard yd
<b>1,0000</b>	0,1000	0,0010	0,0394	0,0033	0,0011
10,0000	<b>1,0000</b>	0,0100	0,3937	0,0328	0,0109
1000,0000	100,0000	<b>1,0000</b>	39,3701	3,2808	1,0936
25,4000	2,5400	0,0254	<b>1,0000</b>	0,0833	0,0278
304,8000	30,4800	0,3048	12,0000	<b>1,0000</b>	0,3333
914,4000	91,4400	0,9144	36,0000	3,0000	<b>1,0000</b>

## VOLUME

cubic metre m <sup>3</sup>	litre litro	millilitre ml	imp. Gallon imp. gal.	US gallon US gal.	cubic foot ft <sup>3</sup>
<b>1,0000</b>	1000,0000	1 x 10 <sup>6</sup>	219,9694	264,1720	35,3147
0,0010	<b>1,0000</b>	1000,0000	0,2200	0,2642	0,0353
1 x 10 <sup>-6</sup>	0,0010	<b>1,0000</b>	2.2 x 10 <sup>-4</sup>	2.642 x 10 <sup>-4</sup>	3.53 x 10 <sup>-5</sup>
0,0045	4,5461	4546,0870	<b>1,0000</b>	1,2009	0,1605
0,0038	3,7854	3785,4120	0,8327	<b>1,0000</b>	0,1337
0,0283	28,3168	28316,8466	6,2288	7,4805	<b>1,0000</b>

G-at\_pp-en\_a\_sc

## FURTHER PRODUCT SELECTION AND DOCUMENTATION

### Xylect

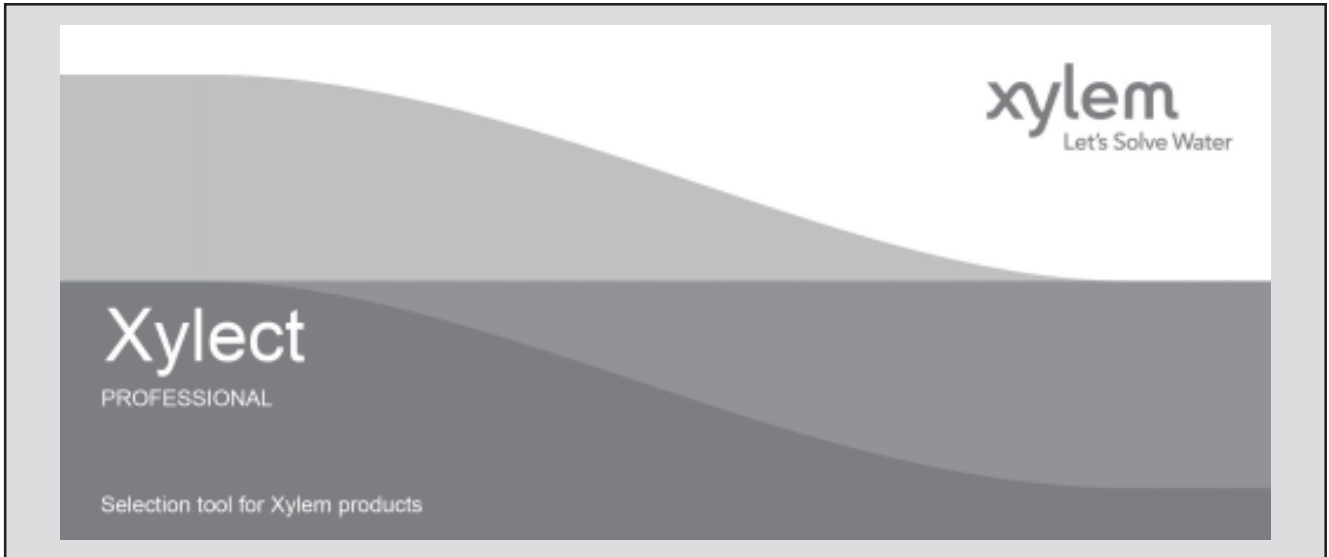

Xylect is pump solution selection software with an extensive online database of product information across the entire Lowara, and Vogel range of pumps and related products, with multiple search options and helpful project management facilities. The system holds up-to-date product information on thousands of products and accessories.

The possibility to search by applications and the detailed information output given makes it easy to make the optimal selection without having detailed knowledge about the Lowara and Vogel products.

The search can be made by:

- Application
- Product type
- Duty point

Xylect gives a detailed output:

- List with search results
- Performance curves (flow, head, power, efficiency, NPSH)
- Motor data
- Dimensional drawings
- Options
- Data sheet printouts
- Document downloads incl dxf files

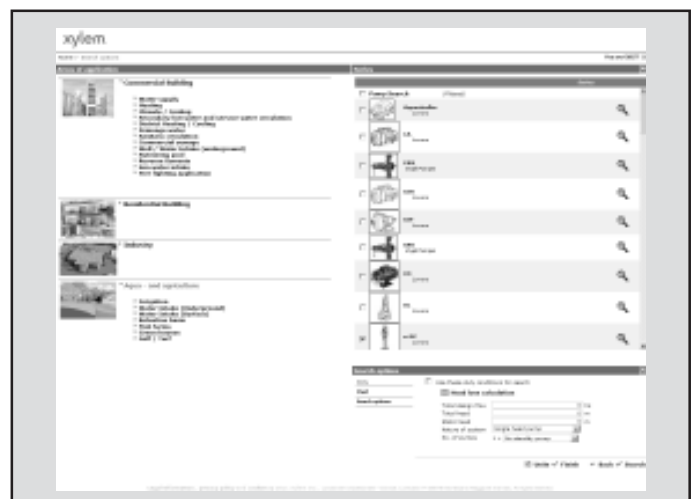

*The search by application guides users not familiar with the product range to the right choice.*

**FURTHER PRODUCT SELECTION AND DOCUMENTATION**

**Xylect**

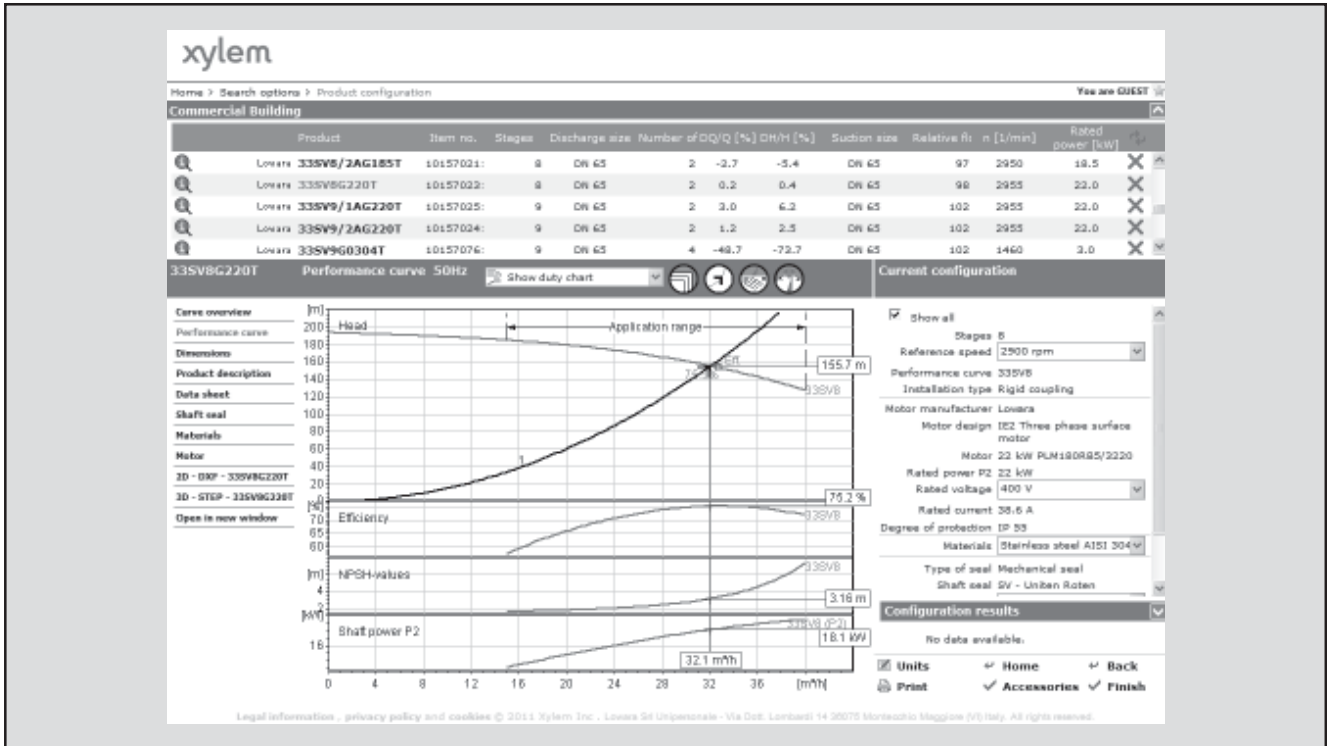

The detailed output makes it easy to select the optimal pump from the given alternatives.

The best way to work with Xylect is to create a personal account. This makes it possible to:

- Set own standard units
- Create and save projects
- Share projects with other Xylect users

Every user has a My Xylect space, where all projects are saved.

For more information about Xylect please contact our sales network or visit [www.xylect.com](http://www.xylect.com).

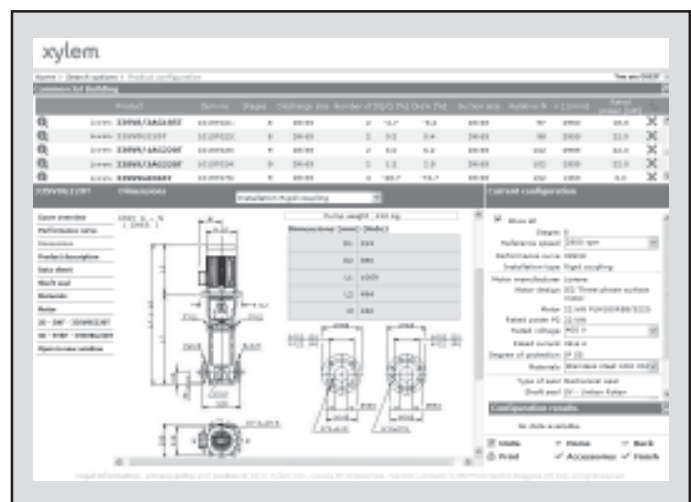

Dimensional drawings appear on the screen and can be downloaded in dxf format.



# Xylem |'zīləm|

- 1) The tissue in plants that brings water upward from the roots;
- 2) a leading global water technology company.

We're 12,000 people unified in a common purpose: creating innovative solutions to meet our world's water needs. Developing new technologies that will improve the way water is used, conserved, and re-used in the future is central to our work. We move, treat, analyze, and return water to the environment, and we help people use water efficiently, in their homes, buildings, factories and farms. In more than 150 countries, we have strong, long-standing relationships with customers who know us for our powerful combination of leading product brands and applications expertise, backed by a legacy of innovation.

**For more information on how Xylem can help you, go to [xylem.com](http://xylem.com).**

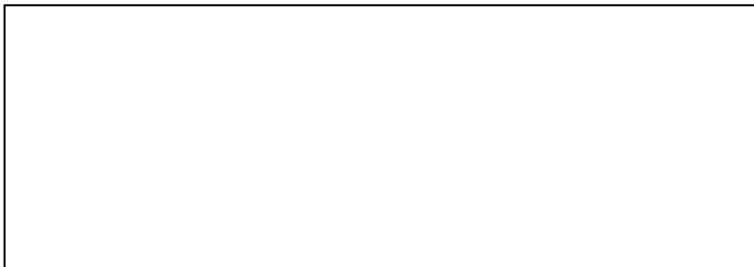

Headquarters

LOWARA S.r.l. Unipersonale

Via Lombardi 14

36075 Montecchio Maggiore - Vicenza - Italy

Tel. (+39) 0444 707111 - Fax (+39) 0444 492166

e-mail: [lowara.mkt@xylem.com](mailto:lowara.mkt@xylem.com)

web: [www.lowara.com](http://www.lowara.com) - [www.completewatersystems.com](http://www.completewatersystems.com)

LOWARA reserves the right to make modification without prior notice.  
LOWARA is a trademark of Xylem Inc. or one of its subsidiaries.