





Fire dampers & Smoke evacuation



Lindab	1
General information and theory	2
Safe	3
Dampers & Measure units	4
Fire dampers & Smoke evacuation	5
Roof hoods	6
Transfer	7
Rectangular	8
Other circular products	9
Flexible ducting	10
Access doors	11
Duct suspensions & Support systems	12
Fastening material	13
Smart tools	14
	15
	16
	17
Index	18

Content

– Fire dampers & Smoke evacuation

1	Circular fire dampers		
		CR60	349
		CR2	351
2			
3	Rectangular fire dampers		
		CU2	354
		CU2L	356
4		CU-LT	364
		CU-LT-1s	381
5	Fire damper		
		MEC	357
6			
7	Frame		
		PG	362
8			
9	Circular smoke evacuation		
		RCJ	398
		RCVF	398
10			
11	Rectangular smoke evacuation		
		VAN1V	399
		VAN2V	401
12			
13	Smoke evacuation		
		MEC	403
14			
15			
16			
17			
18			

Fire dampers

CR60



Dimensions

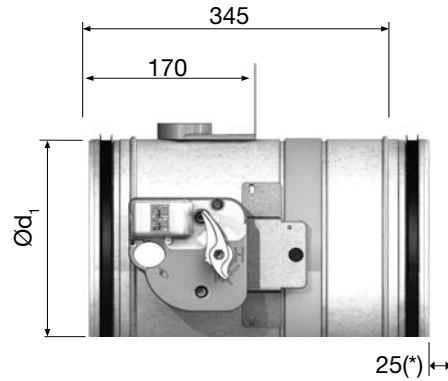

* Extending damper blade only for Ø 315

Description

The CR60 is a very light circular fire damper with a fire resistance up to 90 minutes, which is installed in ventilation ducts passing through a construction element in order to stop the propagation of fire. The refractory casing is made of galvanised steel. The blade consists of asbestos free panels, which are resistant to humidity. The CR60 can be equipped with a fusible link mechanism up to a motorised mechanism, completely out of the wall. The damper is especially designed for smaller diameters up to 315 mm.

Standard

Galvanised steel tunnel

Damper blade (thickness 20 mm)

Operating mechanism with:

- manual command
- manual locking
- blade position indicator
- identification label
- electrical connections
- fusible link 72°C

Rubber air sealing ring

Intumescent strip

Fusible link base plate

Positioning plate

Damper sealing ring

Fire resistance

Up to 90 minutes

Ordering example

	CR60	125	24	MFUS
Product				
Dimension Ød ₁				
Voltage				
Motor type				

Ød ₁ nom
100
125
160
200
250
315

- 1
- 2
- 3
- 4
- 5
- 6
- 7
- 8
- 9
- 10
- 11
- 12
- 13
- 14
- 15
- 16
- 17
- 18

Fire dampers

CR60

Technical data for the motors

MFUS

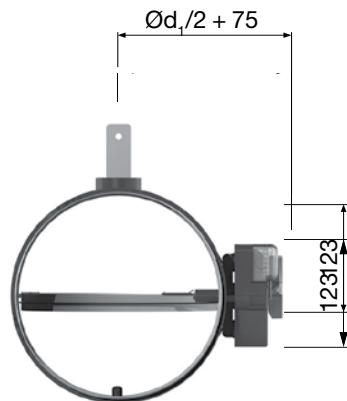

BLFT

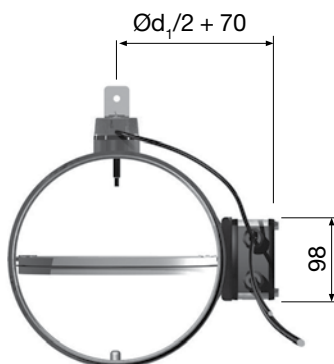

Installation

- In rigid wall, floor and in flexible wall
- Provide an additional zone of 200 mm to have free access to the mechanism
- Avoid deflection of the tunnel
- Installation and air movement may be from either direction
- Verify the free movement of the blade
- Installation according to test report
- On the side of the mechanism the damper exceeds the wall by 170 mm.
- Minimal size of opening to incorporate = $\text{Ød}_1 + 80$ mm in rigid wall and rigid floor/ceiling

Mechanism

MFUS

Automatic command with fusible link 72°C

MFUS + FDCU

End and begin of range switch in option

BLFT

Springreturn actuator 24/230V

rigid wall

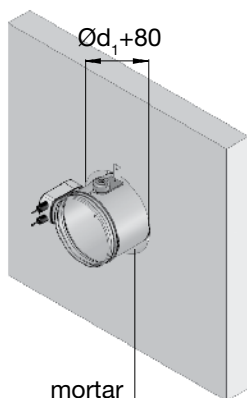

rigid floor/ceiling

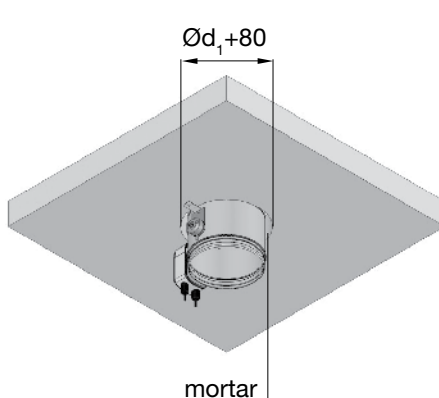

flexible wall

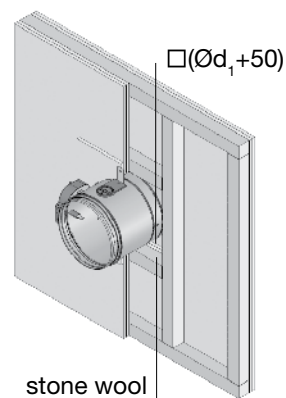

Fire dampers

CR2



Description

The circular fire damper CR2 with a fire resistance of 120 minutes is installed in ventilation ducts passing through a construction element in order to stop the propagation of fire. The fire damper can be equipped with a common fusible link mechanism up to a motorised mechanism, positioned completely outside the wall. The refractory tunnel is made of galvanised steel. The CR2 fire damper is especially designed for larger dimensions up to 630 mm.

Standard

Galvanised steel tunnel

Damper blade

Operating mechanism with:

- manual command
- manual locking
- blade position indicator
- identification label
- electrical connections

Sealing cold smoke

Blade bumper

Intumescent strip

Fusible link 72°C

Fire resistance

2 hours

Ordering example

	CR2	400	230	CFTH
Product				
Dimension $\varnothing d_1$				
Voltage				
Motor type				

Dimensions

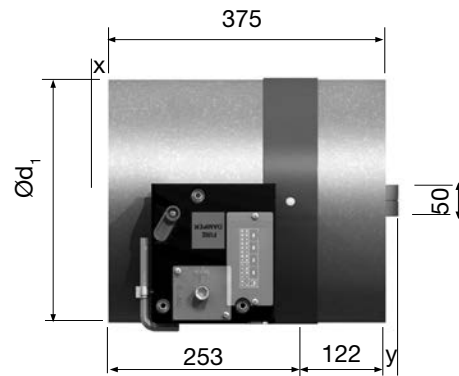

	Exceeding damper blade
$x = \varnothing d_1 - 253 \text{ mm}$	if $\varnothing d_1 \geq 560 \text{ mm}$
$y = \varnothing d_1 - 122 \text{ mm}$	if $\varnothing d_1 \geq 250 \text{ mm}$

$\varnothing d_1$ nom
200
250
315
355
400
450
500
560
630

1
2
3
4
5
6
7
8
9
10
11
12
13
14
15
16
17
18

Fire dampers

CR2

Technical data for the motors

$\varnothing d_1 \geq 315 \text{ mm}$

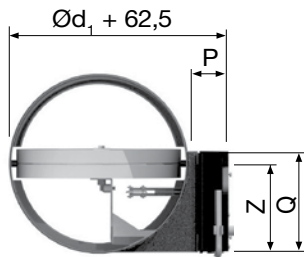

	CFTH	MANO (+ME)	BLF (T)	BF (T)	DB (T)
P	65	115	110	110	145
Q	180	190	210	210	210
Z	155	180	180	180	180

$\varnothing d_1 < 315 \text{ mm}$

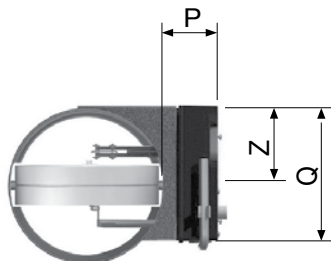

	CFTH	MANO (+ME)	BLF (T)	BF (T)	DB (T)
P	65	115	110	110	145
Q	180	190	210	210	210
Z	60	85	80	-	90

Installation

- Installation in rigid wall with horizontal or vertical axis
- Installation in massive floor or ceiling with horizontal axis
- Provide an additional zone of 200 mm to have free access to the mechanism
- Avoid deflection of the tunnel
- Installation and air movement may be from either direction
- Verify the free movement of the blade
- Installation according to test report
- On the side of the mechanism the damper exceeds the wall by 230 mm
- Minimal size of opening to incorporate = $\varnothing d_1 + 50 \text{ mm}$

Mechanism

CFTH

Automatic command

MANO

Automatic and remote controlled command

BLF/BF/DB

Spring return actuator 24/230V

Function

see MEC, see page 357.

Fire dampers

CR2

Circular reduction piece for connection to a duct with a smaller diameter than the damper.

Delivered per piece.

RCVF

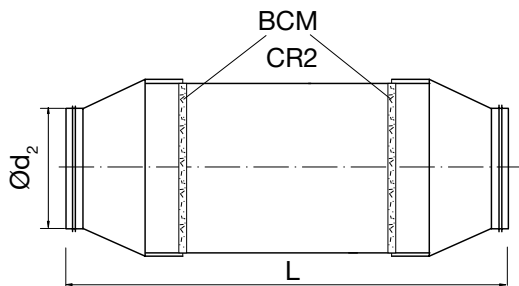
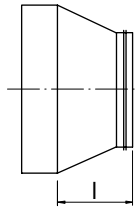

$\varnothing d_2$	$\varnothing d$ CR2	L	l
80	200	665	145
100	200	545	85
125	200	525	75
160	200	495	60
180	200	595	110
224	250	625	125

1

2

3

4

5

6

7

8

9

10

11

12

13

14

15

16

17

18

Fire dampers

CU2



Description

The CU2 is a rectangular fire damper with a fire resistance up to 120 minutes, which is installed in ventilation ducts passing through a construction element in order to stop the propagation of fire. The fire damper can be equipped with a common fusible link mechanism up to a motorised mechanism, completely out of the wall. The refractory casing is made of asbestos free panels, which are resistant to humidity. Suitable for installation in rigid and flexible walls.

Standard

Connection frame PG30

Casing of refractory material

Damper blade

Operating mechanism with:

- manual command
- manual locking
- blade position indicator
- identification label
- electrical connections

Sealing cold smoke

Blade bumper

Intumescent strip

Transmission with locking open/closed

Fusible link 72°C

Ordering example

	CU2	600	500	24	BLF
Product					
Width					
Height					
Voltage					
Motor type					

Dimensions

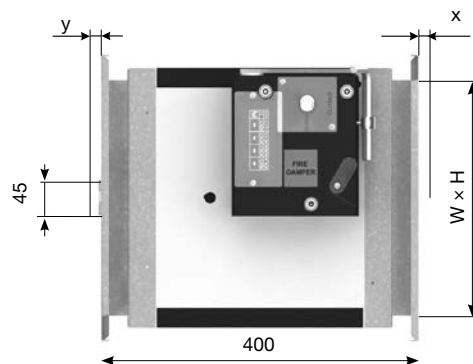

Exceeding damper blade	
$x = H/2 - 274 \text{ mm}$	if $H \geq 550 \text{ mm}$
$y = H/2 - 148 \text{ mm}$	if $H \geq 300 \text{ mm}$

Fire resistance

		EI 120 S	E 120 S	EI 90 S	EI 60 S
Rigid wall	Concrete wall 100 mm ($v_e i \leftrightarrow o$)	up to 600x600 (500 Pa)	up to 1500x1000 (500 Pa)	up to 1500x800 (300 Pa)	up to 1500x1000 (500Pa)
	Concrete floor 150 mm ($h_o i \leftrightarrow o$)	up to 1200x800 (500 Pa)			
Rigid floor	Concrete floor 125 mm ($h_o i \leftrightarrow o$)	up to 1500x800 (300 Pa)			
	Metal stud wall 100 mm ($v_e i \leftrightarrow o$)			up to 1200x800 (500Pa)	up to 1200x800 (500Pa)
Flexible wall	Gypsum block wall 70 mm ($v_e i \leftrightarrow o$)	up to 1200x800 (500 Pa)	up to 1200x800 (500Pa)	up to 1500x800 (300Pa)	up to 1500x800 (300Pa)
				up to 1200x800 (500 Pa)	up to 1200x800 (500 Pa)

v_e = damper mounted directly in the wall

h_o = damper mounted directly in a floor/ceiling

$i \leftrightarrow o$ = fire side randomly

Types of frames

see PG page 362.

Options

EQ – Equipotential connection

UL – Inspection shutter

Fire dampers

CU2

Technical data for the motors

H ≥ 300 mm

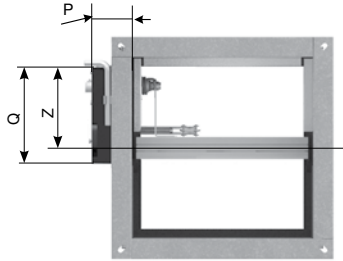

	CFTH	MANO (+ME)	BLF (T)	BF (T)	DB (T)
P	65	115	110	110	145
Q	180	190	210	210	210
Z	155	180	180	180	180

H < 300 mm

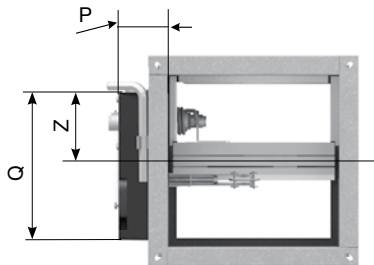

	CFTH	MANO (+ME)	BLF (T)	BF (T)	DB (T)
P	65	115	110	110	145
Q	180	190	210	210	210
Z	60	85	80	-	90

Installation

- Installation in rigid or flexible wall with horizontal or vertical axis
- Installation in rigid floor or ceiling with horizontal axis
- Provide an additional zone of 200 mm to have free access to the mechanism
- Installation and air movement may be from either direction
- Verify the free movement of the blade
- Installation according to test report
- On the side of the mechanism the damper exceeds the wall by 240 mm
- Minimal size of opening to incorporate = (W+100) x (H+100) mm

Mechanism

CFTH

Automatic command

MANO

Automatic and remote controlled command

BL/BLF/DB/RMEX/EMEX

Spring return actuator 24/230V

Function

see MEC page 357.

1
2
3
4
5
6
7
8
9
10
11
12
13
14
15
16
17
18

Fire dampers

CU2L

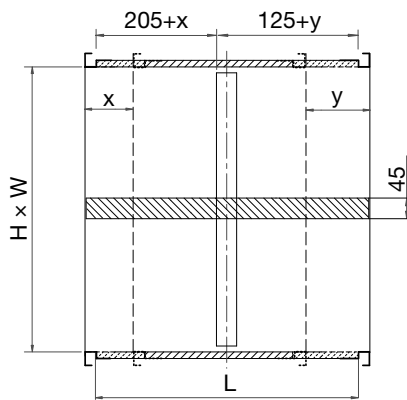

Dimension

L	$330+x+y$	$X = (H/2) - 230$ $Y = (H/2) - 100$	Prolongation on the other side of the mechanism
$x \text{ or } y > 0$			

Description

Elongated duct

The damper CU2L is a damper CU2 of which the duct is extended along one or both sides.

Applications

- the damper blade must not extend beyond one or both sides of the duct
- to allow an easy connection in case of a thick wall
- to allow the installation of a grill on the damper duct

Options

EQ – Equipotential connection

UL – Inspection shutter

Ordering example

	CU2L	600	500
Product			
Width			
Height			

Fire dampers

MEC

MANO (+ME)

The unlocking mechanism MANO unlatches the fire damper blade via remote control by sending an electric impulse (VD) or by interruption (VM) of the magnet's power supply, or automatically, as the fusible link melts when the temperature in the duct rises above 72°C. For high temperatures, the mechanism is supplied with a fusible link of 100 or 140°C. Only possible with the CK2 damper. By unlocking, the internal torsion spring unwinds and releases the damper blade into its closed safety position.

To indicate the open or closed position of the fire damper blade, the mechanism is standard provided with an end and begin of range switch FDCU.

The rearmation has to be done manually (MANO).

The rearmation can be done by a remote controlled electric rearmation motor ME.

Type of magnet

VD: natural magnet

VM: electromagnet

	VM24	VM48	VD24	VD48
Voltage	24 Vdc	48 Vdc	24 Vdc	48 Vdc
Capacity	1,5 W interruption of current		3,5 W impulse of current	

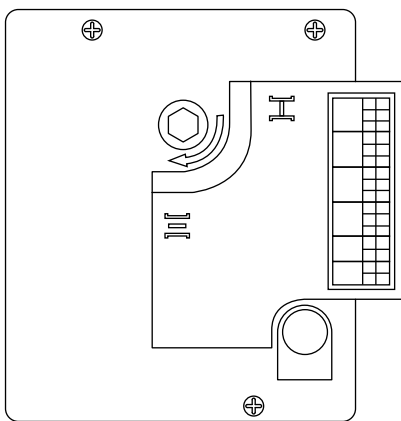

	ME	DCU	FCU	DCB	FCB
+	1	2	3	4	5
-	6	7	8	9	10
+/-	11	12	13	14	15
-/+	16	17	18	19	20

Unlocking

- Manually : by pressing the white button
- Automatically : as the fusible link melts at 72° in the duct
- Remote control : by an electric impulse (VD) or by interruption (VM) of the magnet's power supply

Rearmation

- Manually : turn 90° with hexagon key 13 mm
A magnet with interruption (VM) needs power supply for rearmation
- By electric rearmation motor

Options

Bipolar end and begin of range switch FDCB

Rearmation motor ME.

Voltage	24/48 Vdc ± 10%
	24/48 Vac ± 10%
I_{rms}	1A
I_{max}	± 1,5A

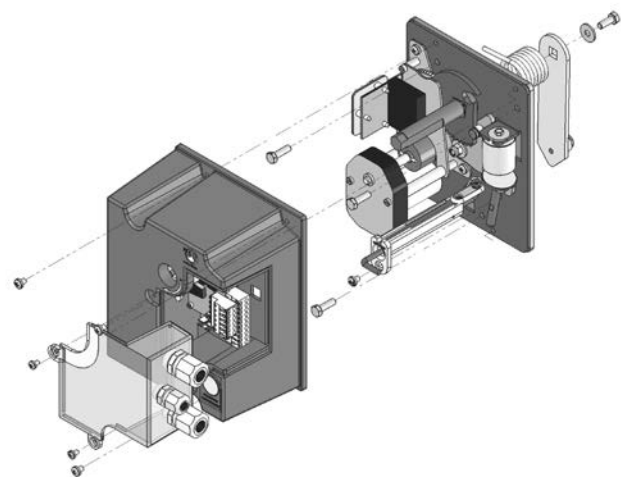

Fire dampers

MEC

BLF – Belimo





When connected to the power supply the servomotor moves the damper blade into its stand-by position.

When the power is interrupted, the internal armed spring returns the damper blade into its safety position.

	BLF 24	BLF 230
Voltage	24 Vdc -10% +20% 24 Vac ±20%	230 Vac ±15%
Consumption holding	2,5 W	3 W
Consumption rearmation	5 W	6 W
Capacity	7 VA	7 VA



W + H ≤ 1200 mm or Ø ≤ 400 mm.

BLF24 BLF230 24V 230V 	BLF24-ST 24V + plug (ST) 	BLFT24 BLFT230 24V 230V + thermo-electric fuse (T) 	BLFT24-ST 24V + plug (ST) + thermo-electric fuse (T) 
--	--	---	---

BLF, BLFT

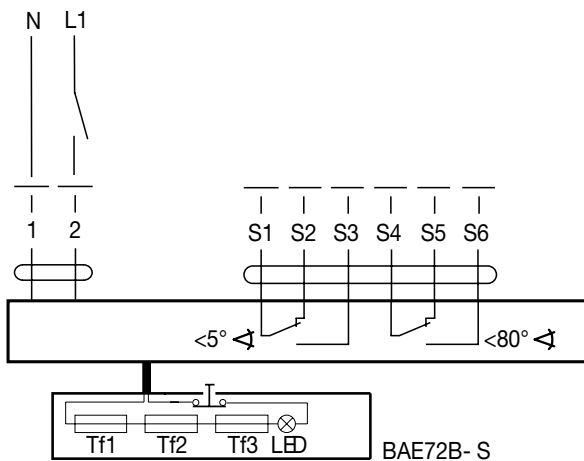

Fire dampers

MEC

BF – Belimo



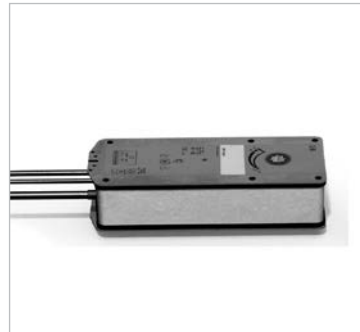

When connected to the power supply the servomotor moves the damper blade into its stand-by position.

When the power is interrupted, the internal armed spring returns the damper blade into its safety position.

	BF 24	BF 230
Voltage	24 Vdc -10% +20% 24 Vac ±20%	230 Vac ±15%
Consumption holding	2 W	3 W
Consumption rearmation	7 W	8 W
Capacity	10 VA	12,5 VA



W + H > 1200 mm or Ø > 400 mm.

BF24 BF230 24V 230V 	BF24-ST 24V + plug (ST) 	BFT24 BFT230 24V 230V + thermo-electric fuse (T) 	BFT24-ST BFT24-TL-ST 24V 24V TOPLINE + plug (ST) + thermo-electric fuse (T)  For bussystem BFT24-TwL-ST
--	---	---	---

Option

Bipolar end and begin of range switches

SN2

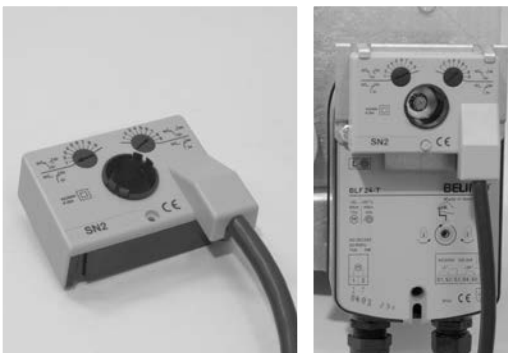

BF, BFT

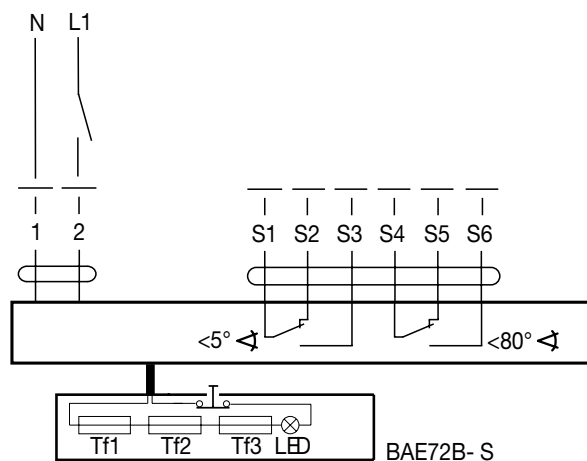

- 1
- 2
- 3
- 4
- 5
- 6
- 7
- 8
- 9
- 10
- 11
- 12
- 13
- 14
- 15
- 16
- 17
- 18

Fire dampers

MEC

DB – Joventa

When connected to the power supply the servomotor moves the damper blade into its stand-by position.

When the power is interrupted, the internal armed spring returns the damper blade into its safety position.

	DB 24	DB 230
Voltage	24 Vdc ±10% 24 Vac ±20%	230 Vac ±10%
Consumption holding	4 W	4,5 W
Consumption rearmation	10 W	8 W
Capacity	18 VA	13 VA



DB24 DB230 24V 230V	DBT24 DBT230 24V 230V + thermo-electric fuse (T)	DBT24 – SLC 24V + thermo-electric fuse (T) Option: BSLC
		

DB, DBT

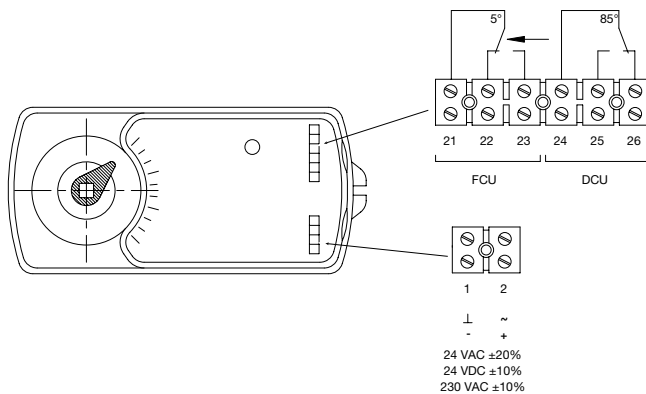

Option

Module for bus system

BSLC



Fire dampers

MEC

EX-Schischek

When connected to the power supply the explosion proof motor moves the damper blade into its standby position.

When the power is interrupted, the internal armed spring returns the damper blade into its closed safety position.

For deflagration risk. Several risk areas are distinguished:

- Zone 1/21 :
average risk of explosion
>100h/year explosive surroundings
- Zone 2/22 :
low risk of explosion
<10h/year of explosive surroundings



		EX 24/230	
Voltage		24...230 Vac/Vdc +15%/-20%	
I_{rms}		24V: 1,45A 230V: 0,3A	
RMAX	RMAXT	EMEX	EMEXT
RedMax 24V/230V	RedMax 24V/230V	ExMax 24V/230V	ExMax 24V/230V
	Thermo-electric fuse (T)		Thermo-electric fuse (T)
Zone 2/22	Zone 2/22	Zone 1/2/21/22	Zone 1/2/21/22
Explosion proof ACTUATOR for CR2/CU2, CU2L			

EX

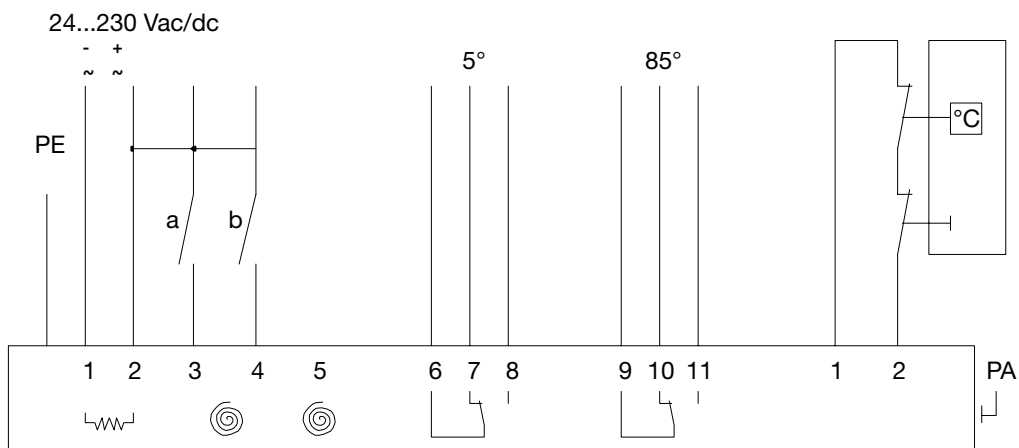

- 1
- 2
- 3
- 4
- 5
- 6
- 7
- 8
- 9
- 10
- 11
- 12
- 13
- 14
- 15
- 16
- 17
- 18

Frame

PG

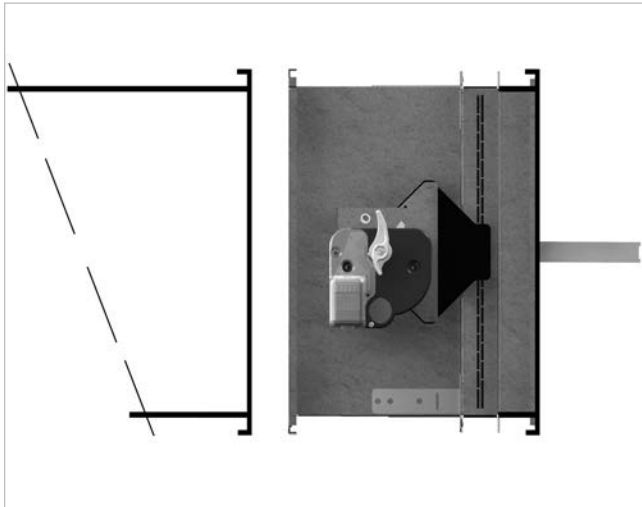

PG30

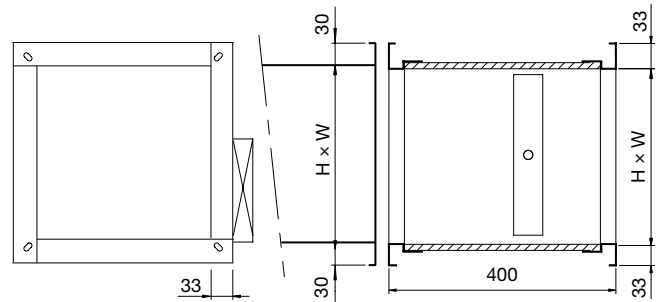

PG20

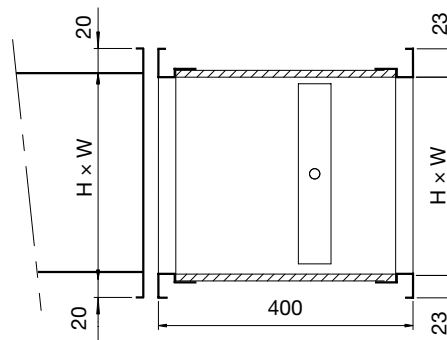

PG40

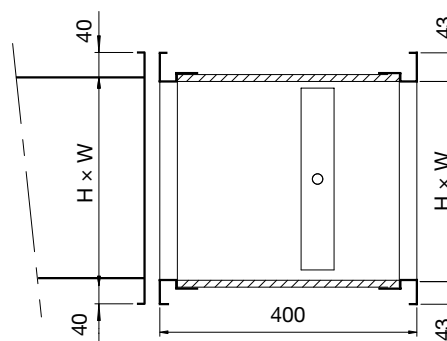

1

2

3

4

5

6

Standard for the damper CU2

PG30

Connection with ducts via frames of 30 mm:

Junction of damper/duct:

- either by sliding profile
- or with bolts
- or with clamps/clips

The four corners of the flange are provided with elliptical holes $\varnothing 8,5 \times 16$ mm.

Variants

PG20

Connection with ducts via frames of 20 mm:

The four corners of the flange are provided with elliptical holes $\varnothing 6,5 \times 16$ mm.

PG40

Connection with ducts via frames of 40 mm:

The four corners of the flange are provided with elliptical holes $\varnothing 8,5 \times 16$ mm.

7

8

9

10

11

12

13

14

15

16

17

18

Frame

PG

Variants

PM

Connection with ducts by socket joint. This type of frame is used in case of shortage of space for standard frames PG30.

PP

No connection

This type of frame is used on transfer dampers or on one side of a damper that opens into a room.

Elongated frame

Elongated frame to avoid that the damper blade extends beyond the damper.

Connection with ducts via frames of 30 mm:

Junction of damper / duct:

- either by sliding profile
- or with bolts
- or with clamps/clips

The four corners of the flange are provided with elliptical holes $\varnothing 8,5 \times 16$ mm

Maximum elongation on 1 side = 500 mm

Maximum elongation on 2 sides = 600 mm

Elongation in steps of 50 mm

PM

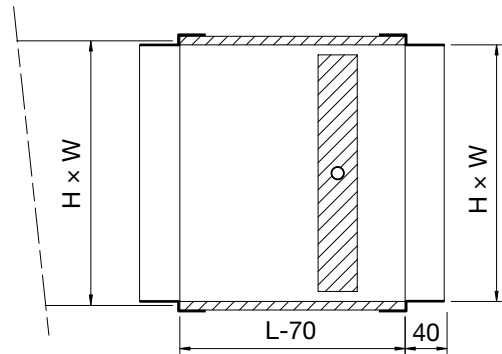

PP

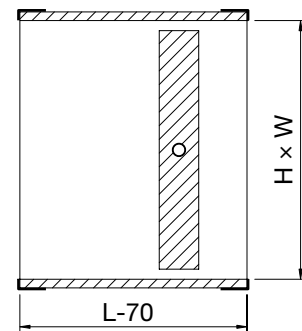

PG3V

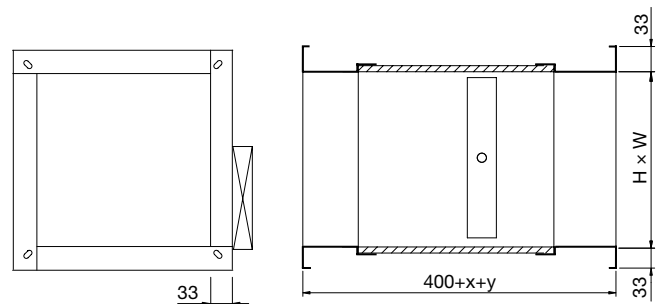

1
2
3
4
5
6
7
8
9
10
11
12
13
14
15
16
17
18

Fire dampers

CU-LT



Dimensions

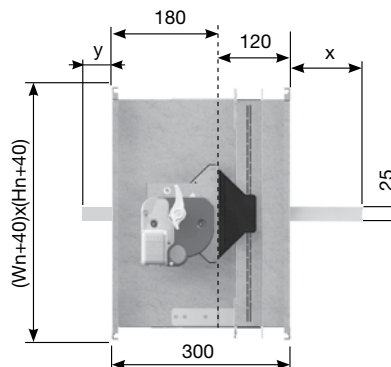

The damper blade exceeds the tunnel:

$$x = (Hn-6)/2 - 70$$

$$y = (Hn-6)/2 - 230$$

Description

Rectangular fire dampers CU-LT are installed in ventilation ducts passing through a construction element in order to stop the propagation of fire. They consist of a modular operating mechanism positioned completely outside the wall.

The rectangular fire damper CU-LT has a fire resistance up to 120 minutes. The casing is made of galvanised steel.

This fire damper is especially designed for smaller dimensions from 200 x 100 to 800 x 600 mm.

The fire damper can be equipped with a fusible link mechanism up to a motorized mechanism.

Standard

- Tested according to EN 1366-2 up to 500Pa
- Minimal pressure drop - very thin damper blade 25 mm
- Air tightness according to EN 1751 minimum class B (class C on demand)
- Suitable for mounting in rigid wall/floor and flexible wall (metal stud gypsum plasterboard)
- Operating mechanism completely outside the wall
- Easy to install
- Maintenance free
- For interior applications

Ordering example

	CU-LT	200	200	MMAG	ME
Product					
Width					
Height					
Type					
Options					

Fire resistance according to EN13501-3 : 2005

		EI 60 S (500 Pa)	EI 90 S (500 Pa)	EI 120 S (500 Pa)
Rigid wall	Aerated concrete wall 100mm (ve i ↔ o)	up to 800x600 (*)	up to 800x600 (**)	up to 800x600 (**)
	Aerated concrete floor 110mm (ho i ↔ o)	up to 800x600 (*)	-	-
Rigid floor	Aerated concrete floor 150mm (ho i ↔ o)	up to 800x600 (*)	up to 800x600 (**)	up to 800x600 (**)
	Light partition wall 100mm (ve i ↔ o)	up to 800x600	up to 800x600	-

(*) sealing with standard concrete mortar or plaster

(**) sealing with plaster

v_e = damper mounted directly in the wall

h_o = damper mounted directly in a floor/ceiling

$i \leftrightarrow o$ = fire can come from either direction

Pa = Pascal

E = integrity

I = thermal insulation

S = smoke leakage

Fire dampers

CU-LT

Types of frames

PG20

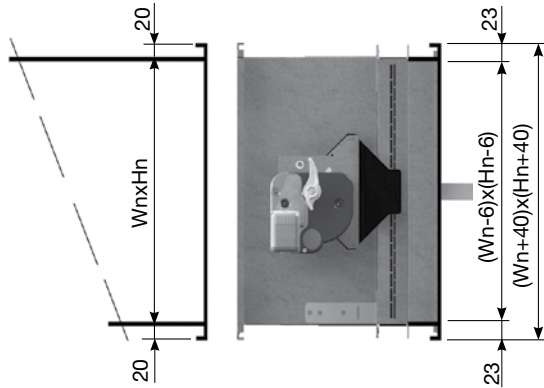

- Connection to ducts with 20 mm flanges (and 30 mm flanges)
- Connection of damper/duct:
 - either with sliding profile (flanges of 20 mm only)
 - or with bolts
- The four corners of the frame are provided with elliptical holes $\varnothing 8,5 \times 16$ mm.

Option

Inspection shutter UL:

An inspection shutter can be used to visually determine the state and the condition (e.g. filth) of the damper. The inspection shutter is always mounted two-fold, one on the lower side and one on the upper side of the fire damper.

Positioning kit flexible wall IFW:

In order to facilitate the installation in a flexible wall, the kit Installation Flexible Wall is available. When ordered together, this kit is mounted on the damper.

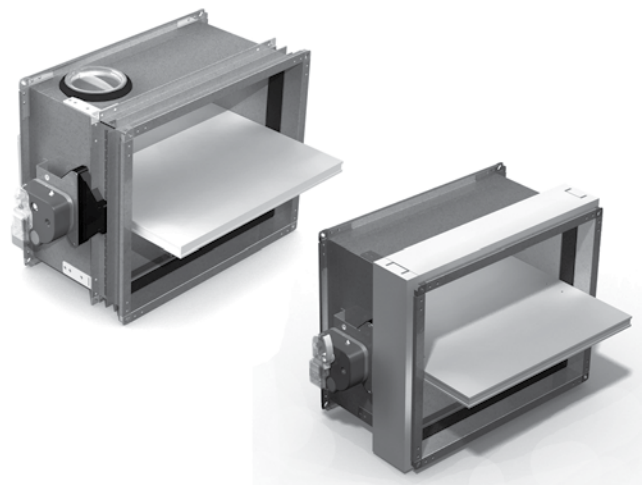

Technical data for the motors

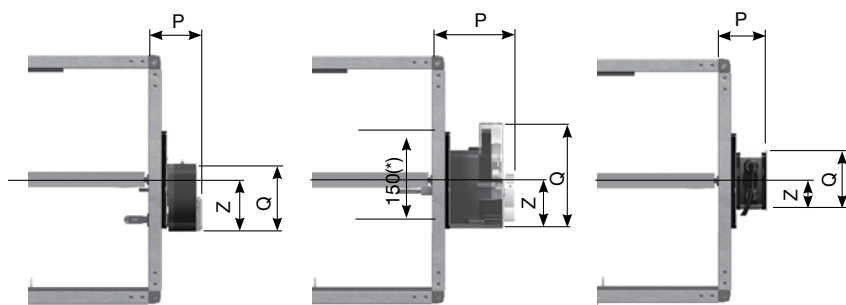

fig. CU-LT + MFUSP

fig. CU-LT + MMAG

fig. CU-LT + BLF(T)

(*) the mechanism and the transmission exceed the damper when $H_n = 100$ mm

If the height < 200 mm the mechanisms MFUSP and MMAG are turned 90° for the assembly.

Height < 200 mm	MFUSP	MMAG	BLF(T)
P	103	150,50	92
Z	62	62	49
Q	125	173	98

Height ≥ 200 mm	MFUSP	MMAG	BLF(T)
P	103	150,50	92
Z	95	95	49
Q	120	125	98

Fire dampers

CU-LT

Weights

Weight CU-LT + MFUSP [kg]

H\W [mm]	200	250	300	350	400	450	500	550	600	650	700	750	800
100	3,7	4,0	4,4	4,8	5,2	5,5	5,9	6,3	6,6	7,0	7,4	7,8	8,1
150	4,1	4,6	5,0	5,4	5,9	6,3	6,7	7,1	7,6	8,0	8,4	8,9	9,3
200	4,6	5,1	5,6	6,1	6,6	7,1	7,5	8,0	8,5	9,0	9,5	10,0	10,4
250	5,1	5,7	6,2	6,7	7,3	7,8	8,4	8,9	9,4	10,0	10,5	11,1	11,6
300	5,6	6,2	6,8	7,4	8,0	8,6	9,2	9,8	10,4	11,0	11,6	12,1	12,7
350	6,1	6,7	7,4	8,0	8,7	9,3	10,0	10,6	11,3	11,9	12,6	13,2	13,9
400	6,6	7,3	8,0	8,7	9,4	10,1	10,8	11,5	12,2	12,9	13,6	14,3	15,0
450	7,1	7,8	8,6	9,3	10,1	10,9	11,6	12,4	13,1	13,9	14,7	15,4	16,2
500	7,5	8,4	9,2	10,0	10,8	11,6	12,4	13,3	14,1	14,9	15,7	16,5	17,3
550	8,0	8,9	9,8	10,6	11,5	12,4	13,3	14,1	15,0	15,9	16,8	17,6	18,5
600	8,5	9,4	10,4	11,3	12,2	13,1	14,1	15,0	15,9	16,9	17,8	18,7	19,7

Weight CU-LT + MMAG (automatic) [kg]

H\W [mm]	200	250	300	350	400	450	500	550	600	650	700	750	800
100	3,9	4,3	4,7	5,0	5,4	5,8	6,1	6,5	6,9	7,3	7,6	8,0	8,4
150	4,4	4,8	5,3	5,7	6,1	6,5	7,0	7,4	7,8	8,3	8,7	9,1	9,5
200	4,9	5,4	5,8	6,3	6,8	7,3	7,8	8,3	8,8	9,2	9,7	10,2	10,7
250	5,4	5,9	6,4	7,0	7,5	8,1	8,6	9,1	9,7	10,2	10,8	11,3	11,8
300	5,8	6,4	7,0	7,6	8,2	8,8	9,4	10,0	10,6	11,2	11,8	12,4	13,0
350	6,3	7,0	7,6	8,3	8,9	9,6	10,2	10,9	11,5	12,2	12,8	13,5	14,1
400	6,8	7,5	8,2	8,9	9,6	10,3	11,1	11,8	12,5	13,2	13,9	14,6	15,3
450	7,3	8,1	8,8	9,6	10,3	11,1	11,9	12,6	13,4	14,2	14,9	15,7	16,4
500	7,8	8,6	9,4	10,2	11,1	11,9	12,7	13,5	14,3	15,1	16,0	16,8	17,6
550	8,3	9,1	10,0	10,9	11,8	12,6	13,5	14,4	15,3	16,1	17,0	17,9	18,7
600	8,8	9,7	10,6	11,5	12,5	13,4	14,3	15,3	16,2	17,1	18,0	19,0	19,9

Weight CU-LT + BLF(T) [kg]

H\W [mm]	200	250	300	350	400	450	500	550	600	650	700	750	800
100	5,0	5,4	5,8	6,1	6,5	6,9	7,2	7,6	8,0	8,4	8,7	9,1	9,5
150	5,5	5,9	6,4	6,8	7,2	7,6	8,1	8,5	8,9	9,4	9,8	10,2	10,6
200	6,0	6,5	6,9	7,4	7,9	8,4	8,9	9,4	9,9	10,3	10,8	11,3	11,8
250	6,5	7,0	7,5	8,1	8,6	9,2	9,7	10,2	10,8	11,3	11,9	12,4	12,9
300	6,9	7,5	8,1	8,7	9,3	9,9	10,5	11,1	11,7	12,3	12,9	13,5	14,1
350	7,4	8,1	8,7	9,4	10,0	10,7	11,3	12,0	12,6	13,3	13,9	14,6	15,2
400	7,9	8,6	9,3	10,0	10,7	11,4	12,2	12,9	13,6	14,3	15,0	15,7	16,4
450	8,4	9,2	9,9	10,7	11,4	12,2	13,0	13,7	14,5	15,3	16,0	16,8	17,5
500	8,9	9,7	10,5	11,3	12,2	13,0	13,8	14,6	15,4	16,2	17,1	17,9	18,7
550	9,4	10,2	11,1	12,0	12,9	13,7	14,6	15,5	16,4	17,2	18,1	19,0	19,8
600	9,9	10,8	11,7	12,6	13,6	14,5	15,4	16,4	17,3	18,2	19,1	20,1	21,0

Fire dampers

CU-LT

Selection graph

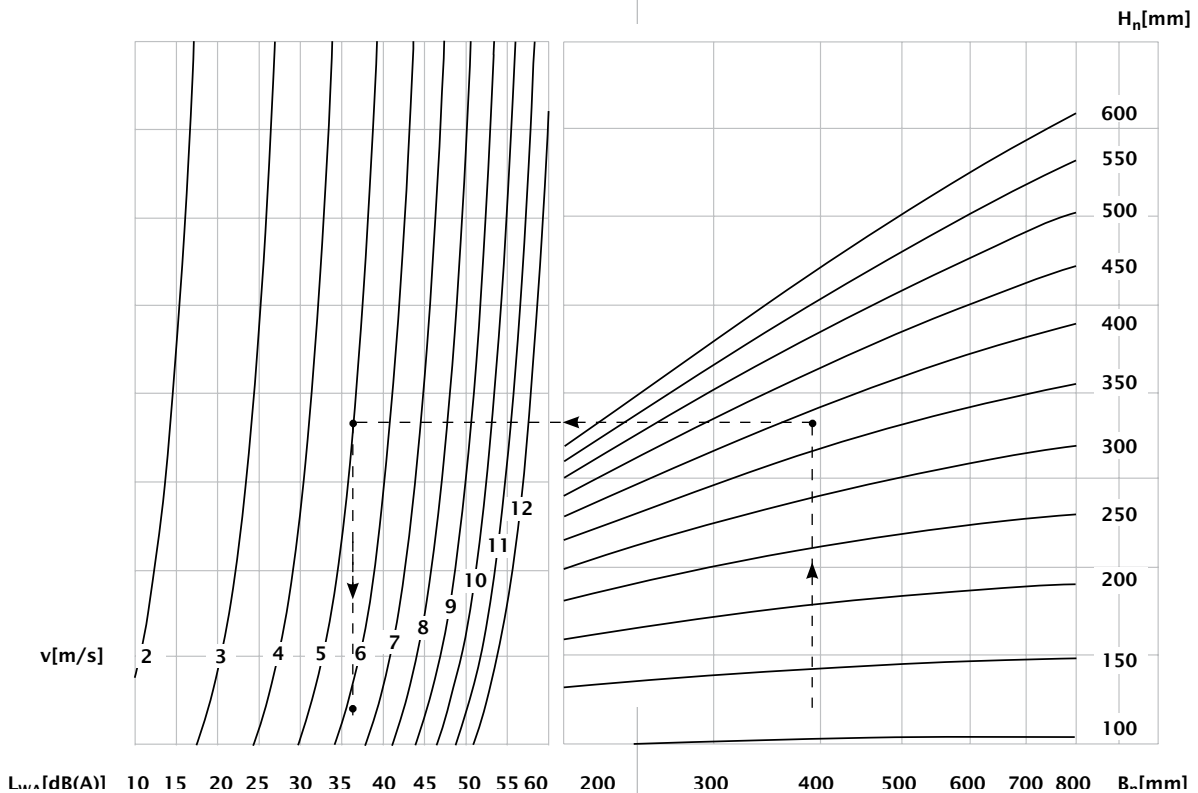
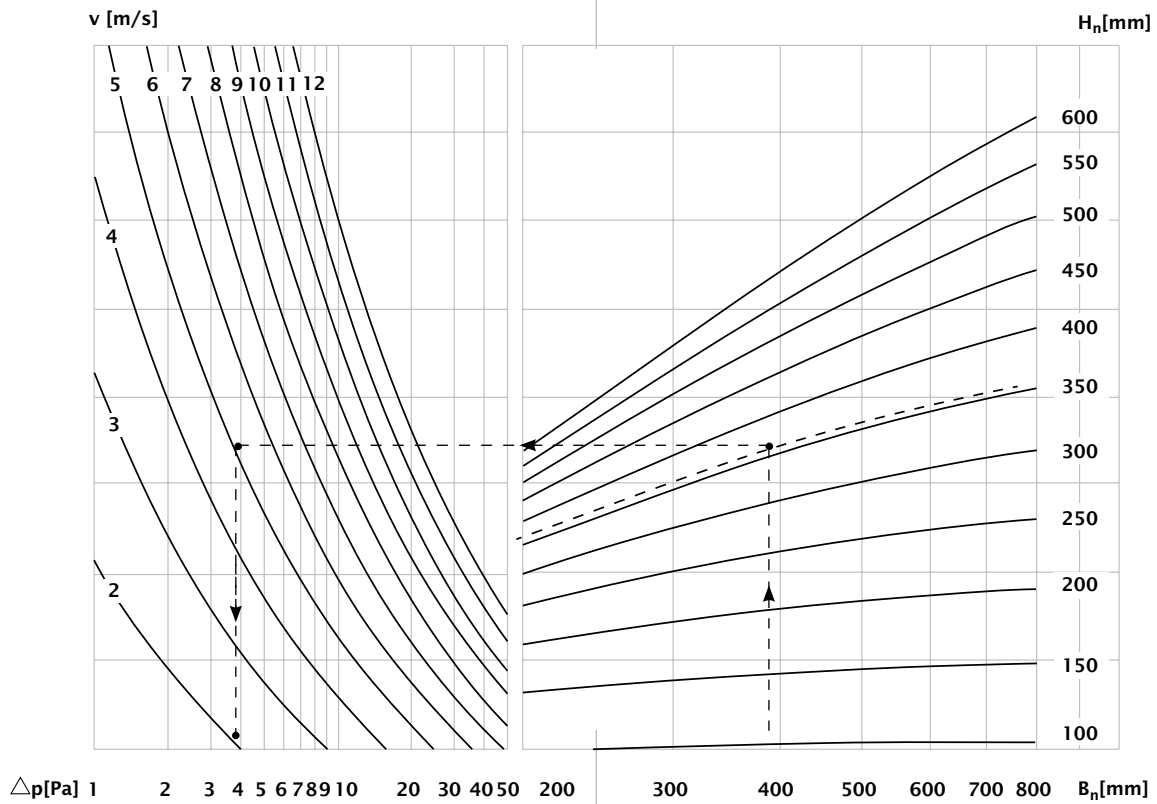

Elaborated example p. 15

- 1
- 2
- 3
- 4
- 5
- 6
- 7
- 8
- 9
- 10
- 11
- 12
- 13
- 14
- 15
- 16
- 17
- 18

Fire dampers

CU-LT

Pressure drop coefficient cu-lt ζ [-]

H\W [mm]	200	250	300	350	400	450	500	550	600	650	700	750	800
100	1,69	1,65	1,62	1,60	1,59	1,58	1,57	1,56	1,55	1,55	1,54	1,54	1,54
150	0,98	0,93	0,89	0,87	0,85	0,83	0,82	0,81	0,80	0,80	0,79	0,79	0,78
200	0,69	0,63	0,60	0,57	0,55	0,54	0,52	0,51	0,51	0,50	0,49	0,49	0,49
250	0,54	0,48	0,44	0,42	0,40	0,39	0,37	0,37	0,36	0,35	0,35	0,34	0,34
300	0,45	0,39	0,35	0,33	0,31	0,30	0,29	0,28	0,27	0,26	0,26	0,26	0,25
350	0,39	0,33	0,30	0,27	0,25	0,24	0,23	0,22	0,22	0,21	0,21	0,20	0,20
400	0,34	0,29	0,26	0,23	0,22	0,20	0,19	0,18	0,18	0,17	0,17	0,16	0,16
450	0,31	0,26	0,23	0,20	0,19	0,17	0,16	0,16	0,15	0,15	0,14	0,14	0,13
500	0,29	0,24	0,20	0,18	0,17	0,15	0,14	0,14	0,13	0,13	0,12	0,12	0,12
550	0,27	0,22	0,19	0,16	0,15	0,14	0,13	0,12	0,12	0,11	0,11	0,10	0,10
600	0,25	0,20	0,17	0,15	0,14	0,12	0,12	0,11	0,10	0,10	0,10	0,09	0,09

$$\Delta p = v^2 \times 0,6 \times \zeta \quad v = \frac{q}{A}$$

q = air flow in the duct [m³/h]

Δp = static pressure drop [Pa]

ζ = pressure drop coefficient zeta [-]

A = internal surface of the duct [m²]

v = air speed in the duct [m/s]

L_{WA} = A-weighted sound power level

H_n/B_n = Nominal height/width of the damper

Example:

Data: $H_n = 350$ mm $W_n = 400$ mm $v = 5$ m/s

Required: $\Delta p = \text{ca. } 3,9$ Pa
 $L_{WA} = \text{ca. } 36$ dB(A) } cfr. selection graph CU-LT

Calculation: $\Delta p = (5\text{m/s})^2 \times 0,6 \times 0,25 = 3,75$ Pa

Fire dampers

CU-LT

Elaborated example of a pressure drop calculation Δp with air speed $v = 4\text{m/s}$

$\Delta p[\text{Pa}]$	200	250	300	350	400	450	500	550	600	650	700	750	800
100	16,22	15,84	15,55	15,36	15,26	15,17	15,07	14,98	14,88	14,88	14,78	14,78	14,78
150	9,41	8,93	8,54	8,35	8,16	7,97	7,87	7,78	7,68	7,68	7,58	7,58	7,49
200	6,62	6,05	5,76	5,47	5,28	5,18	4,99	4,90	4,90	4,80	4,70	4,70	4,70
250	5,18	4,61	4,22	4,03	3,84	3,74	3,55	3,55	3,46	3,36	3,36	3,26	3,26
300	4,32	3,74	3,36	3,17	2,98	2,88	2,78	2,69	2,59	2,50	2,50	2,50	2,40
350	3,74	3,17	2,88	2,59	2,40	2,30	2,21	2,11	2,11	2,02	2,02	1,92	1,92
400	3,26	2,78	2,50	2,21	2,11	1,92	1,82	1,73	1,73	1,63	1,63	1,54	1,54
450	2,98	2,50	2,21	1,92	1,82	1,63	1,54	1,54	1,44	1,44	1,34	1,34	1,25
500	2,78	2,30	1,92	1,73	1,63	1,44	1,34	1,34	1,25	1,25	1,15	1,15	1,15
550	2,59	2,11	1,82	1,54	1,44	1,34	1,25	1,15	1,15	1,06	1,06	0,96	0,96
600	2,40	1,92	1,63	1,44	1,34	1,15	1,15	1,06	0,96	0,96	0,96	0,86	0,86

Elaborated example of a pressure drop calculation Δp with air speed $v = 7\text{m/s}$

$\Delta p[\text{Pa}]$	200	250	300	350	400	450	500	550	600	650	700	750	800
100	49,69	48,51	47,63	47,04	46,75	46,45	46,16	45,86	45,57	45,57	45,28	45,28	45,28
150	28,81	27,34	26,17	25,58	24,99	24,40	24,11	23,81	23,52	23,52	23,23	23,23	22,93
200	20,29	18,52	17,64	16,76	16,17	15,88	15,29	14,99	14,99	14,70	14,41	14,41	14,41
250	15,88	14,11	12,94	12,35	11,76	11,47	10,88	10,88	10,58	10,29	10,29	10,00	10,00
300	13,23	11,47	10,29	9,70	9,11	8,82	8,53	8,23	7,94	7,64	7,64	7,64	7,35
350	11,47	9,70	8,82	7,94	7,35	7,06	6,76	6,47	6,47	6,17	6,17	5,88	5,88
400	10,00	8,53	7,64	6,76	6,47	5,88	5,59	5,29	5,29	5,00	5,00	4,70	4,70
450	9,11	7,64	6,76	5,88	5,59	5,00	4,70	4,70	4,41	4,41	4,12	4,12	3,82
500	8,53	7,06	5,88	5,29	5,00	4,41	4,12	4,12	3,82	3,82	3,53	3,53	3,53
550	7,94	6,47	5,59	4,70	4,41	4,12	3,82	3,53	3,53	3,23	3,23	2,94	2,94
600	7,35	5,88	5,00	4,41	4,12	3,53	3,53	3,23	2,94	2,94	2,94	2,65	2,65

- 1
- 2
- 3
- 4
- 5
- 6
- 7
- 8
- 9
- 10
- 11
- 12
- 13
- 14
- 15
- 16
- 17
- 18

Fire dampers

CU-LT

Selection data CU-LT

A-weighted sound power level L_{WA} of 45 dB(A) in the duct

S_n = Free air passage

Q = Air flow

Δp = Pressure drop

H/W [mm]	200	250	300	350	400	450	500	550	600	650	700	750	800	
100	0,0099	0,0127	0,0154	0,0182	0,0209	0,0237	0,0264	0,0292	0,0319	0,0347	0,0374	0,0402	0,0429	S_n [m ²]
	54,29	55,15	55,72	56,13	56,43	56,67	56,85	57,00	57,13	57,24	57,33	57,41	57,48	S_n [%]
	690	860	1030	1200	1360	1530	1700	1870	2030	2200	2370	2540	2700	Q [m ³ /h]
	93	90	88	87	85	84	84	83	82	82	82	82	81	Δp [Pa]
150	0,0189	0,0242	0,0294	0,0347	0,0399	0,0452	0,0504	0,0557	0,0609	0,0662	0,0714	0,0767	0,0819	S_n [m ²]
	67,65	68,73	69,44	69,95	70,33	70,62	70,85	71,04	71,20	71,33	71,45	71,54	71,63	S_n [%]
	940	1170	1390	1610	1840	2060	2290	2510	2730	2960	3180	3410	3630	Q [m ³ /h]
	24	23	22	21	20	20	20	19	19	19	19	19	18	Δp [Pa]
200	0,0279	0,0357	0,0434	0,0512	0,0589	0,0667	0,0744	0,0822	0,0899	0,0977	0,1054	0,1132	0,1209	S_n [m ²]
	74,13	75,31	76,09	76,65	77,06	77,38	77,63	77,84	78,01	78,16	78,29	78,39	78,49	S_n [%]
	1190	1470	1750	2030	2310	2590	2860	3140	3420	3700	3980	4260	4530	Q [m ³ /h]
	28	25	23	22	21	21	20	19	19	19	19	18	18	Δp [Pa]
250	0,0369	0,0472	0,0574	0,0677	0,0779	0,0882	0,0984	0,1087	0,1189	0,1292	0,1394	0,1497	0,1599	S_n [m ²]
	77,95	79,20	80,02	80,60	81,03	81,37	81,64	81,85	82,04	82,19	82,32	82,44	82,53	S_n [%]
	1440	1770	2100	2440	2770	3100	3430	3760	4090	4420	4750	5090	5420	Q [m ³ /h]
	21	18	16	15	14	14	13	13	12	12	12	12	11	Δp [Pa]
300	0,0459	0,0587	0,0714	0,0842	0,0969	0,1097	0,1224	0,1352	0,1479	0,1607	0,1734	0,1862	0,1989	S_n [m ²]
	80,48	81,76	82,60	83,20	83,65	84,00	84,28	84,50	84,69	84,85	84,99	85,10	85,21	S_n [%]
	1690	2070	2450	2840	3220	3600	3990	4370	4750	5130	5520	5900	6280	Q [m ³ /h]
	16	14	12	11	10	10	9	9	9	8	8	8	8	Δp [Pa]
350	0,0549	0,0702	0,0854	0,1007	0,1159	0,1312	0,1464	0,1617	0,1769	0,1922	0,2074	0,2227	0,2379	S_n [m ²]
	82,26	83,58	84,44	85,05	85,51	85,87	86,15	86,38	86,57	86,74	86,87	86,99	87,10	S_n [%]
	1930	2370	2800	3240	3670	4100	4540	4970	5400	5830	6260	6700	7130	Q [m ³ /h]
	14	11	10	9	8	8	7	7	7	6	6	6	6	Δp [Pa]
400	0,0639	0,0817	0,0994	0,1172	0,1349	0,1527	0,1704	0,1882	0,2059	0,2237	0,2414	0,2592	0,2769	S_n [m ²]
	83,60	84,93	85,81	86,43	86,90	87,26	87,55	87,78	87,98	88,14	88,28	88,41	88,51	S_n [%]
	2170	2660	3150	3630	4110	4600	5080	5560	6040	6520	7000	7480	7960	Q [m ³ /h]
	12	9	8	7	7	6	6	5	5	5	5	5	5	Δp [Pa]
450	0,0729	0,0932	0,1134	0,1337	0,1539	0,1742	0,1944	0,2147	0,2349	0,2552	0,2754	0,2957	0,3159	S_n [m ²]
	84,63	85,98	86,87	87,50	87,98	88,34	88,63	88,87	89,07	89,23	89,38	89,50	89,61	S_n [%]
	2420	2960	3490	4020	4560	5090	5620	6150	6680	7200	7730	8260	8790	Q [m ³ /h]
	10	8	7	6	6	5	5	4	4	4	4	4	4	Δp [Pa]
500	0,0819	0,1047	0,1274	0,1502	0,1729	0,1957	0,2184	0,2412	0,2639	0,2867	0,3094	0,3322	0,3549	S_n [m ²]
	85,46	86,82	87,72	88,36	88,83	89,20	89,49	89,73	89,93	90,10	90,25	90,37	90,48	S_n [%]
	2660	3250	3830	4410	4990	5570	6150	6730	7300	7880	8460	9030	9610	Q [m ³ /h]
	9	7	6	5	5	4	4	4	4	3	3	3	3	Δp [Pa]
550	0,0909	0,1162	0,1414	0,1667	0,1919	0,2172	0,2424	0,2677	0,2929	0,3182	0,3434	0,3687	0,3939	S_n [m ²]
	86,13	87,50	88,41	89,05	89,53	89,90	90,20	90,44	90,64	90,81	90,96	91,08	91,19	S_n [%]
	2900	3540	4170	4800	5430	6060	6680	7300	7930	8550	9170	9790	10420	Q [m ³ /h]
	9	7	5	5	4	4	4	3	3	3	3	3	3	Δp [Pa]
600	0,0999	0,1277	0,1554	0,1832	0,2109	0,2387	0,2664	0,2942	0,3219	0,3497	0,3774	0,4052	0,4329	S_n [m ²]
	86,69	88,07	88,99	89,63	90,11	90,49	90,79	91,03	91,23	91,40	91,55	91,68	91,79	S_n [%]
	3140	3830	4510	5190	5860	6540	7210	7880	8550	9220	9880	10550	11220	Q [m ³ /h]
	8	6	5	4	4	3	3	3	3	3	2	2	2	Δp [Pa]

Every air flow lower than the above mentioned maximum value, will meet the listed A-weighted sound power level 45dB(A), for the respective dimension.

Fire dampers

CU-LT

A-weighted sound power level L_{WA} of 40 dB(A) in the duct

H/W [mm]	200	250	300	350	400	450	500	550	600	650	700	750	800	
100	0,0099	0,0127	0,0154	0,0182	0,0209	0,0237	0,0264	0,0292	0,0319	0,0347	0,0374	0,0402	0,0429	Sn [m ²]
	54,29	55,15	55,72	56,13	56,43	56,67	56,85	57,00	57,13	57,24	57,33	57,41	57,48	Sn [%]
	560	700	840	970	1110	1250	1380	1520	1650	1790	1930	2060	2200	Q [m ³ /h]
	61	60	59	57	57	56	55	55	54	54	54	54	54	Δp [Pa]
150	0,0189	0,0242	0,0294	0,0347	0,0399	0,0452	0,0504	0,0557	0,0609	0,0662	0,0714	0,0767	0,0819	Sn [m ²]
	67,65	68,73	69,44	69,95	70,33	70,62	70,85	71,04	71,20	71,33	71,45	71,54	71,63	Sn [%]
	770	950	1130	1310	1490	1680	1860	2040	2220	2400	2590	2770	2950	Q [m ³ /h]
	30	28	26	25	24	24	23	23	23	22	22	22	22	Δp [Pa]
200	0,0279	0,0357	0,0434	0,0512	0,0589	0,0667	0,0744	0,0822	0,0899	0,0977	0,1054	0,1132	0,1209	Sn [m ²]
	74,13	75,31	76,09	76,65	77,06	77,38	77,63	77,84	78,01	78,16	78,29	78,39	78,49	Sn [%]
	970	1200	1420	1650	1880	2100	2330	2550	2780	3010	3230	3460	3690	Q [m ³ /h]
	19	17	15	15	14	14	13	13	13	12	12	12	12	Δp [Pa]
250	0,0369	0,0472	0,0574	0,0677	0,0779	0,0882	0,0984	0,1087	0,1189	0,1292	0,1394	0,1497	0,1599	Sn [m ²]
	77,95	79,20	80,02	80,60	81,03	81,37	81,64	81,85	82,04	82,19	82,32	82,44	82,53	Sn [%]
	1170	1440	1710	1980	2250	2520	2790	3060	3330	3600	3870	4130	4400	Q [m ³ /h]
	14	12	11	10	9	9	9	8	8	8	8	8	8	Δp [Pa]
300	0,0459	0,0587	0,0714	0,0842	0,0969	0,1097	0,1224	0,1352	0,1479	0,1607	0,1734	0,1862	0,1989	Sn [m ²]
	96,97	98,51	99,53	100,25	100,79	101,21	101,55	101,82	102,05	102,24	102,40	102,54	102,67	Sn [%]
	1370	1680	2000	2310	2620	2930	3240	3550	3860	4170	4480	4790	5110	Q [m ³ /h]
	11	9	8	7	7	6	6	6	6	6	5	5	5	Δp [Pa]
350	0,0549	0,0702	0,0854	0,1007	0,1159	0,1312	0,1464	0,1617	0,1769	0,1922	0,2074	0,2227	0,2379	Sn [m ²]
	82,26	83,58	84,44	85,05	85,51	85,87	86,15	86,38	86,57	86,74	86,87	86,99	87,10	Sn [%]
	1570	1930	2280	2630	2980	3340	3690	4040	4390	4740	5090	5440	5790	Q [m ³ /h]
	9	7	6	6	5	5	5	5	4	4	4	4	4	Δp [Pa]
400	0,0639	0,0817	0,0994	0,1172	0,1349	0,1527	0,1704	0,1882	0,2059	0,2237	0,2414	0,2592	0,2769	Sn [m ²]
	83,60	84,93	85,81	86,43	86,90	87,26	87,55	87,78	87,98	88,14	88,28	88,41	88,51	Sn [%]
	1770	2160	2560	2950	3350	3740	4130	4520	4910	5300	5690	6080	6470	Q [m ³ /h]
	8	6	5	5	4	4	4	4	3	3	3	3	3	Δp [Pa]
450	0,0729	0,0932	0,1134	0,1337	0,1539	0,1742	0,1944	0,2147	0,2349	0,2552	0,2754	0,2957	0,3159	Sn [m ²]
	84,63	85,98	86,87	87,50	87,98	88,34	88,63	88,87	89,07	89,23	89,38	89,50	89,61	Sn [%]
	1970	2400	2840	3270	3700	4140	4570	5000	5430	5860	6290	6720	7150	Q [m ³ /h]
	7	5	5	4	4	3	3	3	3	3	3	3	2	Δp [Pa]
500	0,0819	0,1047	0,1274	0,1502	0,1729	0,1957	0,2184	0,2412	0,2639	0,2867	0,3094	0,3322	0,3549	Sn [m ²]
	85,46	86,82	87,72	88,36	88,83	89,20	89,49	89,73	89,93	90,10	90,25	90,37	90,48	Sn [%]
	2160	2640	3120	3590	4060	4530	5000	5470	5940	6410	6870	7340	7810	Q [m ³ /h]
	6	5	4	4	3	3	3	3	2	2	2	2	2	Δp [Pa]
550	0,0909	0,1162	0,1414	0,1667	0,1919	0,2172	0,2424	0,2677	0,2929	0,3182	0,3434	0,3687	0,3939	Sn [m ²]
	86,13	87,50	88,41	89,05	89,53	89,90	90,20	90,44	90,64	90,81	90,96	91,08	91,19	Sn [%]
	2360	2880	3390	3900	4410	4920	5430	5940	6440	6950	7460	7960	8470	Q [m ³ /h]
	6	4	4	3	3	3	2	2	2	2	2	2	2	Δp [Pa]
600	0,0999	0,1277	0,1554	0,1832	0,2109	0,2387	0,2664	0,2942	0,3219	0,3497	0,3774	0,4052	0,4329	Sn [m ²]
	86,69	88,07	88,99	89,63	90,11	90,49	90,79	91,03	91,23	91,40	91,55	91,68	91,79	Sn [%]
	2560	3110	3670	4220	4770	5310	5860	6400	6950	7490	8040	8580	9120	Q [m ³ /h]
	5	4	3	3	2	2	2	2	2	2	2	2	1	Δp [Pa]

Every air flow lower than the above mentioned maximum value, will meet the listed A-weighted sound power level 40dB(A), for the respective dimension.



Fire dampers

CU-LT

A-weighted sound power level L_{WA} of 35 dB(A) in the duct

H/W [mm]	200	250	300	350	400	450	500	550	600	650	700	750	800	
100	0,0099	0,0127	0,0154	0,0182	0,0209	0,0237	0,0264	0,0292	0,0319	0,0347	0,0374	0,0402	0,0429	Sn [m²]
	54,29	55,15	55,72	56,13	56,43	56,67	56,85	57,00	57,13	57,24	57,33	57,41	57,48	Sn [%]
	460	570	680	790	900	1010	1120	1230	1350	1460	1570	1680	1790	Q [m³/h]
	41	40	39	38	37	37	36	36	36	36	36	36	36	Δp [Pa]
150	0,0189	0,0242	0,0294	0,0347	0,0399	0,0452	0,0504	0,0557	0,0609	0,0662	0,0714	0,0767	0,0819	Sn [m²]
	67,65	68,73	69,44	69,95	70,33	70,62	70,85	71,04	71,20	71,33	71,45	71,54	71,63	Sn [%]
	620	770	920	1070	1220	1360	1510	1660	1810	1960	2100	2250	2400	Q [m³/h]
	19	18	17	17	16	16	15	15	15	15	15	15	14	Δp [Pa]
200	0,0279	0,0357	0,0434	0,0512	0,0589	0,0667	0,0744	0,0822	0,0899	0,0977	0,1054	0,1132	0,1209	Sn [m²]
	74,13	75,31	76,09	76,65	77,06	77,38	77,63	77,84	78,01	78,16	78,29	78,39	78,49	Sn [%]
	790	970	1160	1340	1530	1710	1890	2080	2260	2450	2630	2810	3000	Q [m³/h]
	13	11	10	10	9	9	9	9	8	8	8	8	8	Δp [Pa]
250	0,0369	0,0472	0,0574	0,0677	0,0779	0,0882	0,0984	0,1087	0,1189	0,1292	0,1394	0,1497	0,1599	Sn [m²]
	77,95	79,20	80,02	80,60	81,03	81,37	81,64	81,85	82,04	82,19	82,32	82,44	82,53	Sn [%]
	950	1170	1390	1610	1830	2050	2270	2490	2710	2920	3140	3360	3580	Q [m³/h]
	9	8	7	7	6	6	6	6	5	5	5	5	5	Δp [Pa]
300	0,0459	0,0587	0,0714	0,0842	0,0969	0,1097	0,1224	0,1352	0,1479	0,1607	0,1734	0,1862	0,1989	Sn [m²]
	80,48	81,76	82,60	83,20	83,65	84,00	84,28	84,50	84,69	84,85	84,99	85,10	85,21	Sn [%]
	1120	1370	1620	1880	2130	2380	2640	2890	3140	3390	3650	3900	4150	Q [m³/h]
	7	6	5	5	5	4	4	4	4	4	4	4	3	Δp [Pa]
350	0,0549	0,0702	0,0854	0,1007	0,1159	0,1312	0,1464	0,1617	0,1769	0,1922	0,2074	0,2227	0,2379	Sn [m²]
	82,26	83,58	84,44	85,05	85,51	85,87	86,15	86,38	86,57	86,74	86,87	86,99	87,10	Sn [%]
	1280	1570	1850	2140	2430	2710	3000	3280	3570	3850	4140	4430	4710	Q [m³/h]
	6	5	4	4	4	3	3	3	3	3	3	3	3	Δp [Pa]
400	0,0639	0,0817	0,0994	0,1172	0,1349	0,1527	0,1704	0,1882	0,2059	0,2237	0,2414	0,2592	0,2769	Sn [m²]
	83,60	84,93	85,81	86,43	86,90	87,26	87,55	87,78	87,98	88,14	88,28	88,41	88,51	Sn [%]
	1440	1760	2080	2400	2720	3040	3360	3670	3990	4310	4630	4950	5260	Q [m³/h]
	5	4	4	3	3	3	3	2	2	2	2	2	2	Δp [Pa]
450	0,0729	0,0932	0,1134	0,1337	0,1539	0,1742	0,1944	0,2147	0,2349	0,2552	0,2754	0,2957	0,3159	Sn [m²]
	84,63	85,98	86,87	87,50	87,98	88,34	88,63	88,87	89,07	89,23	89,38	89,50	89,61	Sn [%]
	1600	1950	2310	2660	3010	3360	3710	4060	4410	4760	5110	5460	5810	Q [m³/h]
	5	4	3	3	2	2	2	2	2	2	2	2	2	Δp [Pa]
500	0,0819	0,1047	0,1274	0,1502	0,1729	0,1957	0,2184	0,2412	0,2639	0,2867	0,3094	0,3322	0,3549	Sn [m²]
	85,46	86,82	87,72	88,36	88,83	89,20	89,49	89,73	89,93	90,10	90,25	90,37	90,48	Sn [%]
	1760	2150	2530	2920	3300	3680	4060	4450	4830	5210	5590	5970	6350	Q [m³/h]
	4	3	3	2	2	2	2	2	2	2	1	1	1	Δp [Pa]
550	0,0909	0,1162	0,1414	0,1667	0,1919	0,2172	0,2424	0,2677	0,2929	0,3182	0,3434	0,3687	0,3939	Sn [m²]
	86,13	87,50	88,41	89,05	89,53	89,90	90,20	90,44	90,64	90,81	90,96	91,08	91,19	Sn [%]
	1920	2340	2760	3170	3590	4000	4420	4830	5240	5650	6060	6470	6880	Q [m³/h]
	4	3	2	2	2	2	2	1	1	1	1	1	1	Δp [Pa]
600	0,0999	0,1277	0,1554	0,1832	0,2109	0,2387	0,2664	0,2942	0,3219	0,3497	0,3774	0,4052	0,4329	Sn [m²]
	86,69	88,07	88,99	89,63	90,11	90,49	90,79	91,03	91,23	91,40	91,55	91,68	91,79	Sn [%]
	2080	2530	2980	3430	3880	4320	4760	5210	5650	6090	6530	6970	7410	Q [m³/h]
	4	3	2	2	2	1	1	1	1	1	1	1	1	Δp [Pa]

Every air flow lower than the above mentioned maximum value, will meet the listed A-weighted sound power level 35dB(A), for the respective dimension.

Fire dampers

CU-LT

A-weighted sound power level L_{WA} of 30 dB(A) in the duct

H/W [mm]	200	250	300	350	400	450	500	550	600	650	700	750	800	
100	0,0099	0,0127	0,0154	0,0182	0,0209	0,0237	0,0264	0,0292	0,0319	0,0347	0,0374	0,0402	0,0429	Sn [m ²]
	54,29	55,15	55,72	56,13	56,43	56,67	56,85	57,00	57,13	57,24	57,33	57,41	57,48	Sn [%]
	370	460	550	640	730	820	910	1000	1090	1180	1270	1360	1450	Q [m ³ /h]
	27	26	25	25	24	24	24	24	24	24	24	24	23	Δp [Pa]
150	0,0189	0,0242	0,0294	0,0347	0,0399	0,0452	0,0504	0,0557	0,0609	0,0662	0,0714	0,0767	0,0819	Sn [m ²]
	67,65	68,73	69,44	69,95	70,33	70,62	70,85	71,04	71,20	71,33	71,45	71,54	71,63	Sn [%]
	510	630	750	870	990	1110	1230	1350	1470	1590	1710	1830	1950	Q [m ³ /h]
	13	12	11	11	11	10	10	10	10	10	10	10	10	Δp [Pa]
200	0,0279	0,0357	0,0434	0,0512	0,0589	0,0667	0,0744	0,0822	0,0899	0,0977	0,1054	0,1132	0,1209	Sn [m ²]
	74,13	75,31	76,09	76,65	77,06	77,38	77,63	77,84	78,01	78,16	78,29	78,39	78,49	Sn [%]
	640	790	940	1090	1240	1390	1540	1690	1840	1990	2140	2290	2440	Q [m ³ /h]
	8	7	7	6	6	6	6	6	6	5	5	5	5	Δp [Pa]
250	0,0369	0,0472	0,0574	0,0677	0,0779	0,0882	0,0984	0,1087	0,1189	0,1292	0,1394	0,1497	0,1599	Sn [m ²]
	77,95	79,20	80,02	80,60	81,03	81,37	81,64	81,85	82,04	82,19	82,32	82,44	82,53	Sn [%]
	780	950	1130	1310	1490	1670	1840	2020	2200	2380	2560	2730	2910	Q [m ³ /h]
	6	5	5	4	4	4	4	4	4	3	3	3	3	Δp [Pa]
300	0,0459	0,0587	0,0714	0,0842	0,0969	0,1097	0,1224	0,1352	0,1479	0,1607	0,1734	0,1862	0,1989	Sn [m ²]
	80,48	81,76	82,60	83,20	83,65	84,00	84,28	84,50	84,69	84,85	84,99	85,10	85,21	Sn [%]
	910	1110	1320	1530	1730	1940	2140	2350	2550	2760	2960	3170	3370	Q [m ³ /h]
	5	4	4	3	3	3	3	3	3	2	2	2	2	Δp [Pa]
350	0,0549	0,0702	0,0854	0,1007	0,1159	0,1312	0,1464	0,1617	0,1769	0,1922	0,2074	0,2227	0,2379	Sn [m ²]
	82,26	83,58	84,44	85,05	85,51	85,87	86,15	86,38	86,57	86,74	86,87	86,99	87,10	Sn [%]
	1040	1270	1510	1740	1970	2210	2440	2670	2900	3130	3370	3600	3830	Q [m ³ /h]
	4	3	3	3	2	2	2	2	2	2	2	2	2	Δp [Pa]
400	0,0639	0,0817	0,0994	0,1172	0,1349	0,1527	0,1704	0,1882	0,2059	0,2237	0,2414	0,2592	0,2769	Sn [m ²]
	83,60	84,93	85,81	86,43	86,90	87,26	87,55	87,78	87,98	88,14	88,28	88,41	88,51	Sn [%]
	1170	1430	1690	1950	2210	2470	2730	2990	3250	3500	3760	4020	4280	Q [m ³ /h]
	3	3	2	2	2	2	2	2	2	1	1	1	1	Δp [Pa]
450	0,0729	0,0932	0,1134	0,1337	0,1539	0,1742	0,1944	0,2147	0,2349	0,2552	0,2754	0,2957	0,3159	Sn [m ²]
	84,63	85,98	86,87	87,50	87,98	88,34	88,63	88,87	89,07	89,23	89,38	89,50	89,61	Sn [%]
	1300	1590	1880	2160	2450	2730	3020	3300	3590	3870	4150	4440	4720	Q [m ³ /h]
	3	2	2	2	2	1	1	1	1	1	1	1	1	Δp [Pa]
500	0,0819	0,1047	0,1274	0,1502	0,1729	0,1957	0,2184	0,2412	0,2639	0,2867	0,3094	0,3322	0,3549	Sn [m ²]
	85,46	86,82	87,72	88,36	88,83	89,20	89,49	89,73	89,93	90,10	90,25	90,37	90,48	Sn [%]
	1430	1750	2060	2370	2680	2990	3300	3610	3920	4230	4540	4850	5160	Q [m ³ /h]
	3	2	2	2	1	1	1	1	1	1	1	1	1	Δp [Pa]
550	0,0909	0,1162	0,1414	0,1667	0,1919	0,2172	0,2424	0,2677	0,2929	0,3182	0,3434	0,3687	0,3939	Sn [m ²]
	86,13	87,50	88,41	89,05	89,53	89,90	90,20	90,44	90,64	90,81	90,96	91,08	91,19	Sn [%]
	1560	1900	2240	2580	2920	3250	3590	3920	4260	4590	4930	5260	5600	Q [m ³ /h]
	3	2	2	1	1	1	1	1	1	1	1	1	1	Δp [Pa]
600	0,0999	0,1277	0,1554	0,1832	0,2109	0,2387	0,2664	0,2942	0,3219	0,3497	0,3774	0,4052	0,4329	Sn [m ²]
	86,69	88,07	88,99	89,63	90,11	90,49	90,79	91,03	91,23	91,40	91,55	91,68	91,79	Sn [%]
	1690	2060	2420	2790	3150	3510	3870	4230	4590	4950	5310	5670	6030	Q [m ³ /h]
	2	2	1	1	1	1	1	1	1	1	1	1	1	Δp [Pa]

Every air flow lower than the above mentioned maximum value, will meet the listed A-weighted sound power level 30dB(A), for the respective dimension.



Fire dampers

CU-LT

A-weighted sound power level LWA of 25dB(A) in the duct

H/W [mm]	200	250	300	350	400	450	500	550	600	650	700	750	800	
100	0,0099	0,0127	0,0154	0,0182	0,0209	0,0237	0,0264	0,0292	0,0319	0,0347	0,0374	0,0402	0,0429	Sn [m ²]
	54,29	55,15	55,72	56,13	56,43	56,67	56,85	57,00	57,13	57,24	57,33	57,41	57,48	Sn [%]
	310	380	450	520	600	670	740	820	890	960	1040	1110	1180	Q [m ³ /h]
	19	18	17	16	17	16	16	16	16	16	16	16	15	Δp [Pa]
150	0,0189	0,0242	0,0294	0,0347	0,0399	0,0452	0,0504	0,0557	0,0609	0,0662	0,0714	0,0767	0,0819	Sn [m ²]
	67,65	68,73	69,44	69,95	70,33	70,62	70,85	71,04	71,20	71,33	71,45	71,54	71,63	Sn [%]
	410	510	610	710	810	900	1000	1100	1200	1290	1390	1490	1590	Q [m ³ /h]
	9	8	8	7	7	7	7	7	7	6	6	6	6	Δp [Pa]
200	0,0279	0,0357	0,0434	0,0512	0,0589	0,0667	0,0744	0,0822	0,0899	0,0977	0,1054	0,1132	0,1209	Sn [m ²]
	74,13	75,31	76,09	76,65	77,06	77,38	77,63	77,84	78,01	78,16	78,29	78,39	78,49	Sn [%]
	520	640	770	890	1010	1130	1250	1370	1500	1620	1740	1860	1980	Q [m ³ /h]
	5	5	5	4	4	4	4	4	4	4	4	3	3	Δp [Pa]
250	0,0369	0,0472	0,0574	0,0677	0,0779	0,0882	0,0984	0,1087	0,1189	0,1292	0,1394	0,1497	0,1599	Sn [m ²]
	77,95	79,20	80,02	80,60	81,03	81,37	81,64	81,85	82,04	82,19	82,32	82,44	82,53	Sn [%]
	630	780	920	1070	1210	1360	1500	1640	1790	1930	2080	2220	2370	Q [m ³ /h]
	4	3	3	3	3	3	2	2	2	2	2	2	2	Δp [Pa]
300	0,0459	0,0587	0,0714	0,0842	0,0969	0,1097	0,1224	0,1352	0,1479	0,1607	0,1734	0,1862	0,1989	Sn [m ²]
	80,48	81,76	82,60	83,20	83,65	84,00	84,28	84,50	84,69	84,85	84,99	85,10	85,21	Sn [%]
	740	910	1070	1240	1410	1580	1740	1910	2080	2240	2410	2580	2740	Q [m ³ /h]
	3	3	2	2	2	2	2	2	2	2	2	2	2	Δp [Pa]
350	0,0549	0,0702	0,0854	0,1007	0,1159	0,1312	0,1464	0,1617	0,1769	0,1922	0,2074	0,2227	0,2379	Sn [m ²]
	82,26	83,58	84,44	85,05	85,51	85,87	86,15	86,38	86,57	86,74	86,87	86,99	87,10	Sn [%]
	850	1040	1230	1420	1600	1790	1980	2170	2360	2550	2740	2930	3110	Q [m ³ /h]
	3	2	2	2	2	1	1	1	1	1	1	1	1	Δp [Pa]
400	0,0639	0,0817	0,0994	0,1172	0,1349	0,1527	0,1704	0,1882	0,2059	0,2237	0,2414	0,2592	0,2769	Sn [m ²]
	83,60	84,93	85,81	86,43	86,90	87,26	87,55	87,78	87,98	88,14	88,28	88,41	88,51	Sn [%]
	950	1160	1380	1590	1800	2010	2220	2430	2640	2850	3060	3270	3480	Q [m ³ /h]
	2	2	2	1	1	1	1	1	1	1	1	1	1	Δp [Pa]
450	0,0729	0,0932	0,1134	0,1337	0,1539	0,1742	0,1944	0,2147	0,2349	0,2552	0,2754	0,2957	0,3159	Sn [m ²]
	84,63	85,98	86,87	87,50	87,98	88,34	88,63	88,87	89,07	89,23	89,38	89,50	89,61	Sn [%]
	1060	1290	1530	1760	1990	2220	2450	2690	2920	3150	3380	3610	3840	Q [m ³ /h]
	2	2	1	1	1	1	1	1	1	1	1	1	1	Δp [Pa]
500	0,0819	0,1047	0,1274	0,1502	0,1729	0,1957	0,2184	0,2412	0,2639	0,2867	0,3094	0,3322	0,3549	Sn [m ²]
	85,46	86,82	87,72	88,36	88,83	89,20	89,49	89,73	89,93	90,10	90,25	90,37	90,48	Sn [%]
	1160	1420	1680	1930	2180	2430	2690	2940	3190	3440	3690	3940	4200	Q [m ³ /h]
	2	1	1	1	1	1	1	1	1	1	1	1	1	Δp [Pa]
550	0,0909	0,1162	0,1414	0,1667	0,1919	0,2172	0,2424	0,2677	0,2929	0,3182	0,3434	0,3687	0,3939	Sn [m ²]
	86,13	87,50	88,41	89,05	89,53	89,90	90,20	90,44	90,64	90,81	90,96	91,08	91,19	Sn [%]
	1270	1550	1820	2100	2370	2650	2920	3190	3460	3730	4010	4280	4550	Q [m ³ /h]
	2	1	1	1	1	1	1	1	1	1	1	1	0	Δp [Pa]
600	0,0999	0,1277	0,1554	0,1832	0,2109	0,2387	0,2664	0,2942	0,3219	0,3497	0,3774	0,4052	0,4329	Sn [m ²]
	86,69	88,07	88,99	89,63	90,11	90,49	90,79	91,03	91,23	91,40	91,55	91,68	91,79	Sn [%]
	1380	1670	1970	2270	2560	2860	3150	3440	3730	4030	4320	4610	4900	Q [m ³ /h]
	2	1	1	1	1	1	1	1	1	0	0	0	0	Δp [Pa]

Every air flow lower than the above mentioned maximum value, will meet the listed A-weighted sound power level 25dB(A), for the respective dimension. Additional data can be consulted on our website.

Fire dampers

CU-LT

Correction factor ΔL

To obtain the sound power level for the $L_{W \text{ oct}}$ octave midband

L_{WA} = A-weighted sound power level

ΔL = Correction factor

$L_{W \text{ oct}}$ = Sound power level for each octave midband

$$L_{W \text{ oct}} = \Delta L + L_{WA}$$

[Hz]	63	125	250	500	1000	2000	4000	8000
2 - 4 m/s	22	9	-2	-11	-18	-21	-17	-8
6 - 8 m/s	17	10	1	-4	-8	-13	-19	-21
10 - 12 m/s	15	9	0	-4	-7	-10	-14	-20

Deduct L_{WA} from the selection graph on page 342.

1

2

3

4

5

6

7

8

9

10

11

12

13

14

15

16

17

18

Fire dampers

CU-LT

Operating mechanisms

MFUSP: simple operating mechanism with fusible link
 The operating mechanism MFUSP automatically unlocks the blade when the temperature in the duct exceeds 72°C.

The damper needs to be rearmed manually.

- Standard:**
- Fusible link 72° C
 - Manual unlocking possible
 - Manual rearmation, use the rearmation handle (turn clockwise)
 - IP42
- Options:**
- FDCU: Unipolar beginning and end of range switches

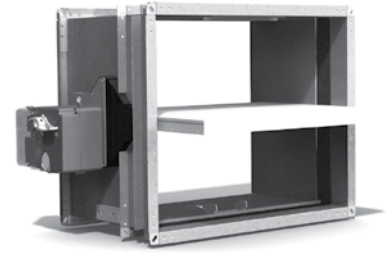

fig. CU-LT + MFUSP

MMAG: Upgradable automatic / remote controlled operating mechanism with fusible link

The operating mechanism MMAG automatically unlocks the blade when the temperature in the duct exceeds 72°C. It can also close the damper by sending an electrical impulse (VD) or by interrupting the power supply (VM) to the magnet.

Manual or motorized rearmation (ME MMAG).

- Standard:**
- Fusible link 72° C
 - Manual unlocking possible
 - Manual rearmation, use a rearmation handle (turn clockwise)
 - IP42
- Options:**
- Remote controlled by means of a dual voltage magnet 24/48V
- Types of magnets:**
- VD = natural magnet
 - VM = electromagnet
- FDCU : Unipolar beginning and end of range switches
 - FDCB : Bipolar beginning and end of range switches
 - ME : Rearmation motor

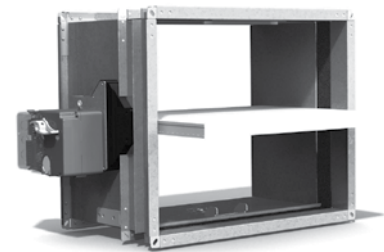

fig. CU-LT + MMAG

BLF(T) : spring-return actuator (with thermo-electric fuse)

When connected to the power supply, the actuator moves the blade into its standby position (open). When the power is interrupted, an internal armed spring closes the blade (safety position).

If the motor is equipped with a thermo-electric fuse BLFT, this will interrupt the power supply when the temperature in the duct exceeds 72°C.

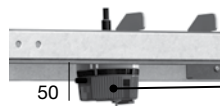

fig. thermo-electric fuse

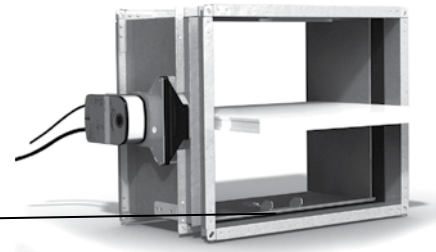







fig. CU-LT + BLFT

Technical data

Operating mechanism	CU-LT MFUSP	CU-LT MMAG	CU-LT BLF(T)
Description	Automatic fire damper	Upgradable automatic and remote controlled damper	Motorized remote controlled damper with spring-return actuator
Certifications	 		 
Classification	Fire resistance : - EI 120 (ve i↔o) S : range until 800 x 600 : Mounting in rigid wall min. 100 mm - EI 90 (ve i↔o) S : range until 800 x 600 : Mounting in flexible wall 60' min. 100 mm - EI 60 (ho i↔o) S : range until 800 x 600 : Mounting in rigid floor/ceiling min. 110 mm - EI 60 (ve i↔o) S : range until 800 x 600 : Mounting in rigid wall min. 110 mm - EI 120 (ho i↔o) S : range until 800 x 600 : Mounting in rigid floor/ceiling min. 150 mm Pressure during test : 500 Pa		

Fire dampers

CU-LT

Electrical connections

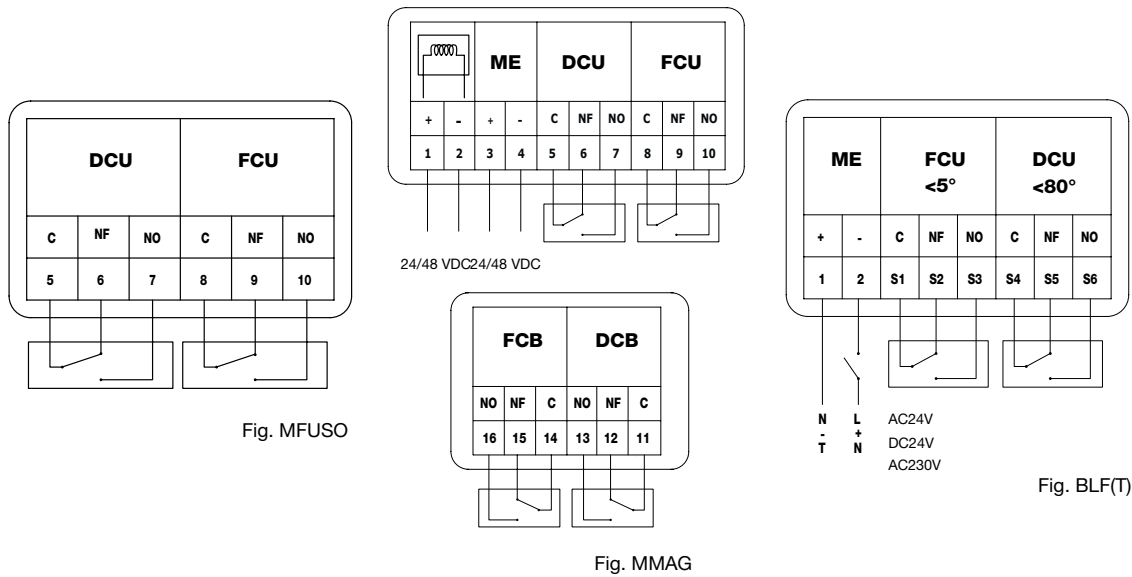

MFUSP	MMAG	BLF(T)
Power supply MFUSP	Power supply motor/ magnet MMAG	Power supply motor BLF(T)
n.a.	Rearmation motor (ME): 24/48 VDC (automatic switch) Magnet: 24/48 VDC (automatic switch)	BLF(T)24: 24VAC / 24VDC BLF(T)230: 230VAC
Power consumption	Power consumption	Power consumption
n.a. n.a. n.a.	Rearmation motor (ME): 24VDC : Pmax = 10W 48VDC : Pmax = 15W Magnet: VM: Pnom = 1,5W VD: Pmax = 3,5W	BLF(T)24: motoring: 5W holding: 2,5W BLF(T)230: motoring: 6W holding: 3W
Position switches	Position switches	Position swwitches
Standard: 1mA...1A, DC 5V...AC 48V	Standard: 1mA...500mA, DC 5V...AC 48V	Standard: 1mA...3A, DC 5V...AC 250V SN2: 1mA...3A, DC 5V...AC 250V
Running time	Running time	Running time
motor: n.a spring: 1s	Motor: < 30 s spring: 1s	motor: 40 ... 75s spring: 20s
Noise level	Noise level	Noise level
n.a.	Motor: max 66 DB (A)	motor: max 45 dB (A) spring: ca. 62 dB (A)
Degree of protection	Degree of protection	Degree of protection
IP 45	IP 45	IP 54



Fire dampers

CU-LT

Position of the thermo-electric fuse for BLFT(T)

Height	Width	Position
≤ 300mm	= 200mm	on the side opposite to the mechanism
	> 200mm	on the W-side next to the inspection shutter
> 300mm		on the same side of the mechanism

The mechanism is always mounted on the H-side.

Standard:

- Thermo-electric fuse 72°C for BLFT
- Motorized unlocking and rearmation
- Manual rearmation possible, use the enclosed handle turn clockwise
- 24V or 230V
- Integrated unipolar begin and end of range switches
- IP 54

Options:

- SN2 Bipolar begin and end of range switches
- ST plug

Fire dampers

CU-LT





Evolution kits

	KITS MFUSP	
	Automatic operating mechanism MFUSP with fusible link 72°C	
	KITS FUS 72 MFUS(P)	
	Fusible link 72°C for MFUS(P)	
	KITS FDCU MFUS(P)	
	Unipolar beginning and end of range switches FDCU for MFUS(P)	
	KITS MMAG	
	Upgradable operating mechanism MMAG with fusible link 72°C	
	KITS FUS 72 MMAG	
	Fusible link 72°C for MMAG	
	KITS VD MMAG FDCU	KITS VM MMAG FDCU
	Magnet VD24/48, VM24/48 with FDCU for MMAG	
	KITS ME MMAG	
	Rearmation motor ME 24/48 for MMAG	
	KITS FDCU MMAG	
	Unipolar beginning and end of range switches FDCU for MMAG	

1
2
3
4
5
6
7
8
9
10
11
12
13
14
15
16
17
18

Fire dampers

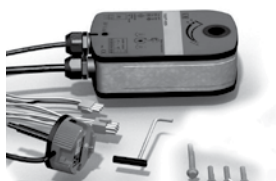
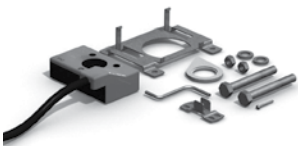
CU-LT

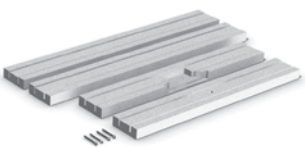
1		KITS FDCB MMAG	
		Bipolar beginning and end of range switches FDCB for MMAG	
3		KITS BLF 24	KITS BLF 24-ST
		KITS BLF 230	
Actuator Belimo BLF 24V/230V or BLF 24V with plug (ST), without thermo-electric fuse (T)			
5		KITS BLFT 24	KITS BLFT 24-ST
		KITS BLFT 230	
Actuator Belimo BLF 24V/230V or BLF 24V with plug (ST) and thermo-electric fuse (T)			
7		KITS SN2 BLF	
		Bipolar beginning and end of range switches FDCB for BLF actuator	
9		KITS BAE 72	
		Thermo-electric fuse 72°C (T) for Belimo BLFT 24V	
11		KITS CULT-IFW	
		Positioning kit flexible wall	

Fire dampers

CU-LT-1s



Description

Rectangular fire dampers CU-LT-1s are installed wall mounted in ventilation ducts passing through a construction element in order to stop the propagation of fire. They exist of a modular operating mechanism positioned completely outside the wall.

The rectangular fire damper CU-LT-1s has a fire resistance up to 120 minutes. The casing is made of galvanised steel. This fire damper is especially designed for smaller dimensions from 200x100 up to 800x600mm.

The fire damper can be equipped with a fusible link mechanism up to a motorized mechanism.

Standard

- Tested according to EN 1366-2 up to 500Pa
- Minimal pressure drop - very thin damper blade 25mm
- Air tightness according to EN 1751 minimum class B (class C on demand)
- Suitable for installing wall mounted on rigid wall/floor and flexible wall (metal stud gypsum plasterboard and gypsum blocs)
- Operating mechanism completely outside the wall
- Easy to install
- Maintenance free
- For interior applications

Ordering example

	CU-LT-1s	200	200	MMAG	ME
Product					
Width					
Height					
Type					
Options					

Dimensions

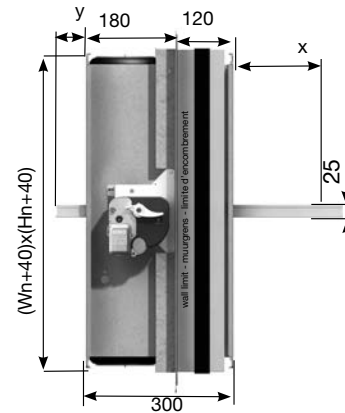

The damper blade exceeds the tunnel:

$$x = (Hn-6)/2 - 70$$

$$y = (Hn-6)/2 - 230$$

Fire resistance according to EN 13501-3 : 2005

		EI 120 S (500 Pa)	EI 90 S (500 Pa)
Rigid wall	Aerated concrete wall 100mm (ve i ↔ o)	up to 800x600	
Rigid floor	Aerated concrete floor 150mm (ho i ↔ o)	(*)	(*)
Flexible wall	Light partition wall 100mm (ve i ↔ o)		up to 800x600
Flexible wall	Gypsum blocks wall 70mm (ve i ↔ o)	up to 800x600	

v_o = damper mounted directly in the wall
 h_o = damper mounted directly in a floor/ceiling
 i ↔ o = fire can come from either direction
 Pa = Pascal
 E = integrity
 I = thermal insulation
 S = smoke leakage
 (*) result is not yet available



Fire dampers

CU-LT-1s

Types of frames

PG20

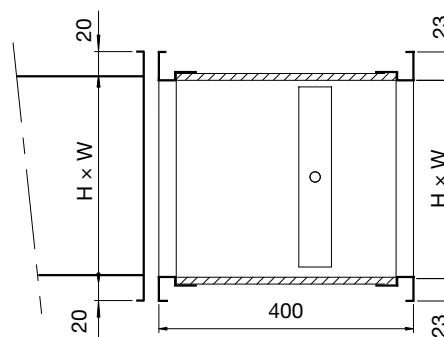
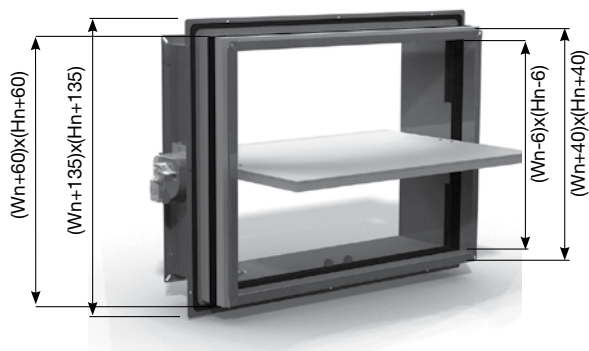

- Connection to ducts with 20 mm flanges (and 30 mm flanges)
- Connection of damper/duct:
 - either with sliding profile (flanges of 20 mm only)
 - or with bolts
- The four corners of the frame are provided with elliptical holes $\varnothing 8,5 \times 16$ mm.

Option : inspection shutter ul

An inspection shutter can be used to visualise the position and the condition (e.g. filth) of the damper. The inspection shutter is always mounted two-fold, one on the lower side and one on the upper side of the fire damper.



Technical data for the motors

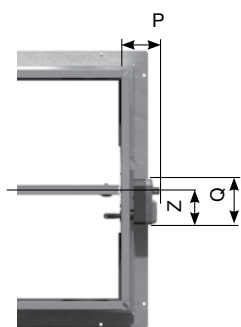

fig. CU-LT-1s + MFUSP

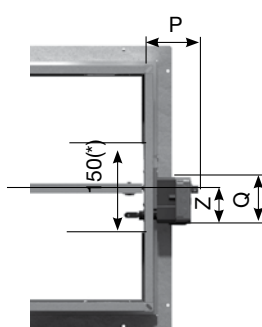

fig. CU-LT-1s + MMAG

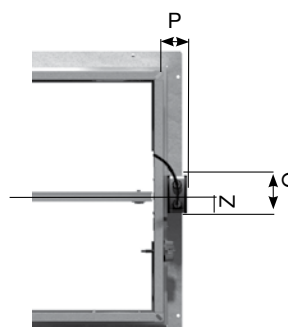

fig. CU-LT-1s + BLF(T)

(*) The mechanism and the transmission stick out with $H_n = 100$ mm

If the height < 200 mm the mechanisms MFUSP and MMAG are turned 90° for the assembly.

Height < 200 mm	MFUSP	MMAG	BLF(T)
P	103	150,50	92
Z	62	62	49
Q	125	173	98

Height \geq 200 mm	MFUSP	MMAG	BLF(T)
P	103	150,50	92
Z	95	95	49
Q	120	125	98

Fire dampers

CU-LT-1s

Weights

Weight CU-LT-1s + MFUSP [kg]

H\W [mm]	200	250	300	350	400	450	500	550	600	650	700	750	800
100	3,7	4,0	4,4	4,8	5,2	5,5	5,9	6,3	6,6	7,0	7,4	7,8	8,1
150	4,1	4,6	5,0	5,4	5,9	6,3	6,7	7,1	7,6	8,0	8,4	8,9	9,3
200	4,6	5,1	5,6	6,1	6,6	7,1	7,5	8,0	8,5	9,0	9,5	10,0	10,4
250	5,1	5,7	6,2	6,7	7,3	7,8	8,4	8,9	9,4	10,0	10,5	11,1	11,6
300	5,6	6,2	6,8	7,4	8,0	8,6	9,2	9,8	10,4	11,0	11,6	12,1	12,7
350	6,1	6,7	7,4	8,0	8,7	9,3	10,0	10,6	11,3	11,9	12,6	13,2	13,9
400	6,6	7,3	8,0	8,7	9,4	10,1	10,8	11,5	12,2	12,9	13,6	14,3	15,0
450	7,1	7,8	8,6	9,3	10,1	10,9	11,6	12,4	13,1	13,9	14,7	15,4	16,2
500	7,5	8,4	9,2	10,0	10,8	11,6	12,4	13,3	14,1	14,9	15,7	16,5	17,3
550	8,0	8,9	9,8	10,6	11,5	12,4	13,3	14,1	15,0	15,9	16,8	17,6	18,5
600	8,5	9,4	10,4	11,3	12,2	13,1	14,1	15,0	15,9	16,9	17,8	18,7	19,7

Weight CU-LT-1s + MMAG (automatic) [kg]

H\W [mm]	200	250	300	350	400	450	500	550	600	650	700	750	800
100	3,9	4,3	4,7	5,0	5,4	5,8	6,1	6,5	6,9	7,3	7,6	8,0	8,4
150	4,4	4,8	5,3	5,7	6,1	6,5	7,0	7,4	7,8	8,3	8,7	9,1	9,5
200	4,9	5,4	5,8	6,3	6,8	7,3	7,8	8,3	8,8	9,2	9,7	10,2	10,7
250	5,4	5,9	6,4	7,0	7,5	8,1	8,6	9,1	9,7	10,2	10,8	11,3	11,8
300	5,8	6,4	7,0	7,6	8,2	8,8	9,4	10,0	10,6	11,2	11,8	12,4	13,0
350	6,3	7,0	7,6	8,3	8,9	9,6	10,2	10,9	11,5	12,2	12,8	13,5	14,1
400	6,8	7,5	8,2	8,9	9,6	10,3	11,1	11,8	12,5	13,2	13,9	14,6	15,3
450	7,3	8,1	8,8	9,6	10,3	11,1	11,9	12,6	13,4	14,2	14,9	15,7	16,4
500	7,8	8,6	9,4	10,2	11,1	11,9	12,7	13,5	14,3	15,1	16,0	16,8	17,6
550	8,3	9,1	10,0	10,9	11,8	12,6	13,5	14,4	15,3	16,1	17,0	17,9	18,7
600	8,8	9,7	10,6	11,5	12,5	13,4	14,3	15,3	16,2	17,1	18,0	19,0	19,9

Weight CU-LT-1s + BLF(T) [kg]

H\W [mm]	200	250	300	350	400	450	500	550	600	650	700	750	800
100	5,0	5,4	5,8	6,1	6,5	6,9	7,2	7,6	8,0	8,4	8,7	9,1	9,5
150	5,5	5,9	6,4	6,8	7,2	7,6	8,1	8,5	8,9	9,4	9,8	10,2	10,6
200	6,0	6,5	6,9	7,4	7,9	8,4	8,9	9,4	9,9	10,3	10,8	11,3	11,8
250	6,5	7,0	7,5	8,1	8,6	9,2	9,7	10,2	10,8	11,3	11,9	12,4	12,9
300	6,9	7,5	8,1	8,7	9,3	9,9	10,5	11,1	11,7	12,3	12,9	13,5	14,1
350	7,4	8,1	8,7	9,4	10,0	10,7	11,3	12,0	12,6	13,3	13,9	14,6	15,2
400	7,9	8,6	9,3	10,0	10,7	11,4	12,2	12,9	13,6	14,3	15,0	15,7	16,4
450	8,4	9,2	9,9	10,7	11,4	12,2	13,0	13,7	14,5	15,3	16,0	16,8	17,5
500	8,9	9,7	10,5	11,3	12,2	13,0	13,8	14,6	15,4	16,2	17,1	17,9	18,7
550	9,4	10,2	11,1	12,0	12,9	13,7	14,6	15,5	16,4	17,2	18,1	19,0	19,8
600	9,9	10,8	11,7	12,6	13,6	14,5	15,4	16,4	17,3	18,2	19,1	20,1	21,0



Fire dampers

CU-LT-1s

Selection graph

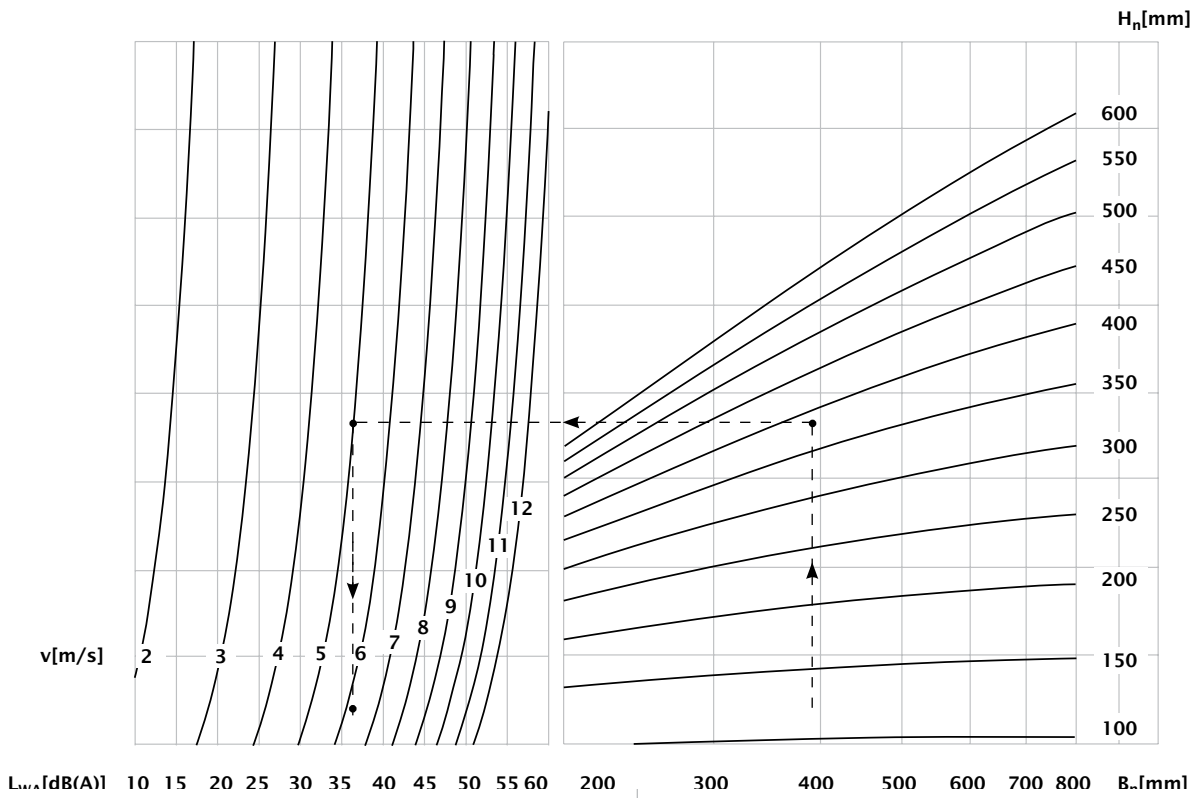
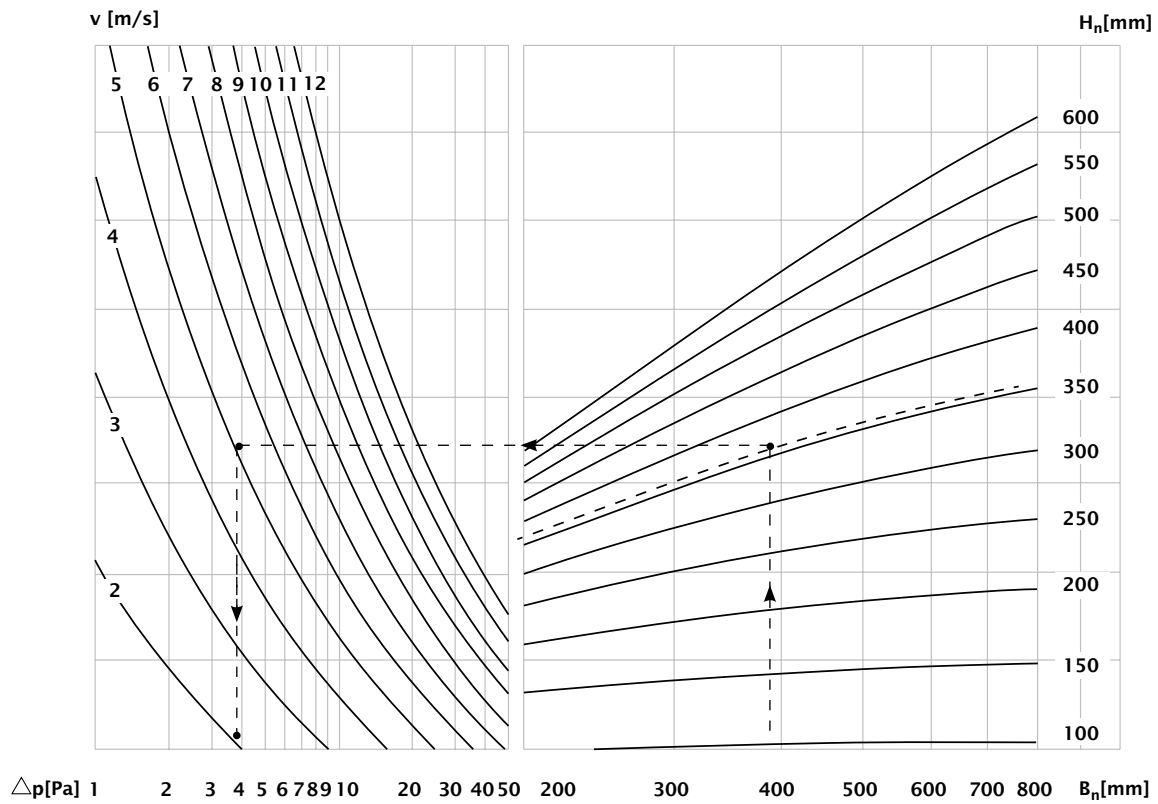

Elaborated example p. 15

Fire dampers

CU-LT-1s

Pressure drop coefficient cu-lt-1s ζ [-]

H/W [mm]	200	250	300	350	400	450	500	550	600	650	700	750	800
100	1,69	1,65	1,62	1,60	1,59	1,58	1,57	1,56	1,55	1,55	1,54	1,54	1,54
150	0,98	0,93	0,89	0,87	0,85	0,83	0,82	0,81	0,80	0,80	0,79	0,79	0,78
200	0,69	0,63	0,60	0,57	0,55	0,54	0,52	0,51	0,51	0,50	0,49	0,49	0,49
250	0,54	0,48	0,44	0,42	0,40	0,39	0,37	0,37	0,36	0,35	0,35	0,34	0,34
300	0,45	0,39	0,35	0,33	0,31	0,30	0,29	0,28	0,27	0,26	0,26	0,26	0,25
350	0,39	0,33	0,30	0,27	0,25	0,24	0,23	0,22	0,22	0,21	0,21	0,20	0,20
400	0,34	0,29	0,26	0,23	0,22	0,20	0,19	0,18	0,18	0,17	0,17	0,16	0,16
450	0,31	0,26	0,23	0,20	0,19	0,17	0,16	0,16	0,15	0,15	0,14	0,14	0,13
500	0,29	0,24	0,20	0,18	0,17	0,15	0,14	0,14	0,13	0,13	0,12	0,12	0,12
550	0,27	0,22	0,19	0,16	0,15	0,14	0,13	0,12	0,12	0,11	0,11	0,10	0,10
600	0,25	0,20	0,17	0,15	0,14	0,12	0,12	0,11	0,10	0,10	0,10	0,09	0,09

$$\Delta p = v^2 \times 0,6 \times \zeta \quad v = \frac{q}{A}$$

q = air flow in the duct [m³/h]

Δp = static pressure drop [Pa]

ζ = pressure drop coefficient zeta [-]

A = internal surface of the duct [m²]

v = air speed in the duct [m/s]

L_{WA} = A-weighted sound power level

H_n/B_n = Nominal height/width of the damper

Example:

Data: $H_n = 350 \text{ mm}$ $W_n = 400 \text{ mm}$ $v = 5 \text{ m/s}$
 Required: $\Delta p = \text{ca. } 3,9 \text{ Pa}$
 $L_{WA} = \text{ca. } 36 \text{ dB(A)}$ } cfr. selection graph CU-LT-1s
 Calculation: $\Delta p = (5\text{m/s})^2 \times 0,6 \times 0,25 = 3,75 \text{ Pa}$

- 1
- 2
- 3
- 4
- 5
- 6
- 7
- 8
- 9
- 10
- 11
- 12
- 13
- 14
- 15
- 16
- 17
- 18

Fire dampers

CU-LT-1s

Elaborated example of a pressure drop calculation Δp with air speed $v = 4\text{ m/s}$

$\Delta p[\text{Pa}]$	200	250	300	350	400	450	500	550	600	650	700	750	800
100	16,22	15,84	15,55	15,36	15,26	15,17	15,07	14,98	14,88	14,88	14,78	14,78	14,78
150	9,41	8,93	8,54	8,35	8,16	7,97	7,87	7,78	7,68	7,68	7,58	7,58	7,49
200	6,62	6,05	5,76	5,47	5,28	5,18	4,99	4,90	4,90	4,80	4,70	4,70	4,70
250	5,18	4,61	4,22	4,03	3,84	3,74	3,55	3,55	3,46	3,36	3,36	3,26	3,26
300	4,32	3,74	3,36	3,17	2,98	2,88	2,78	2,69	2,59	2,50	2,50	2,50	2,40
350	3,74	3,17	2,88	2,59	2,40	2,30	2,21	2,11	2,11	2,02	2,02	1,92	1,92
400	3,26	2,78	2,50	2,21	2,11	1,92	1,82	1,73	1,73	1,63	1,63	1,54	1,54
450	2,98	2,50	2,21	1,92	1,82	1,63	1,54	1,54	1,44	1,44	1,34	1,34	1,25
500	2,78	2,30	1,92	1,73	1,63	1,44	1,34	1,34	1,25	1,25	1,15	1,15	1,15
550	2,59	2,11	1,82	1,54	1,44	1,34	1,25	1,15	1,15	1,06	1,06	0,96	0,96
600	2,40	1,92	1,63	1,44	1,34	1,15	1,15	1,06	0,96	0,96	0,96	0,86	0,86

Elaborated example of a pressure drop calculation Δp with air speed $v = 7\text{ m/s}$

$\Delta p[\text{Pa}]$	200	250	300	350	400	450	500	550	600	650	700	750	800
100	49,69	48,51	47,63	47,04	46,75	46,45	46,16	45,86	45,57	45,57	45,28	45,28	45,28
150	28,81	27,34	26,17	25,58	24,99	24,40	24,11	23,81	23,52	23,52	23,23	23,23	22,93
200	20,29	18,52	17,64	16,76	16,17	15,88	15,29	14,99	14,99	14,70	14,41	14,41	14,41
250	15,88	14,11	12,94	12,35	11,76	11,47	10,88	10,88	10,58	10,29	10,29	10,00	10,00
300	13,23	11,47	10,29	9,70	9,11	8,82	8,53	8,23	7,94	7,64	7,64	7,64	7,35
350	11,47	9,70	8,82	7,94	7,35	7,06	6,76	6,47	6,47	6,17	6,17	5,88	5,88
400	10,00	8,53	7,64	6,76	6,47	5,88	5,59	5,29	5,29	5,00	5,00	4,70	4,70
450	9,11	7,64	6,76	5,88	5,59	5,00	4,70	4,70	4,41	4,41	4,12	4,12	3,82
500	8,53	7,06	5,88	5,29	5,00	4,41	4,12	4,12	3,82	3,82	3,53	3,53	3,53
550	7,94	6,47	5,59	4,70	4,41	4,12	3,82	3,53	3,53	3,23	3,23	2,94	2,94
600	7,35	5,88	5,00	4,41	4,12	3,53	3,53	3,23	2,94	2,94	2,94	2,65	2,65

Fire dampers

CU-LT-1s

Selection data CU-LT-1s

A-weighted sound power level L_{WA} of 45 dB(A) in the duct

S_n = Free air passage

Q = Air flow

Δp = Pressure drop

H/W [mm]	200	250	300	350	400	450	500	550	600	650	700	750	800	
100	0,0099	0,0127	0,0154	0,0182	0,0209	0,0237	0,0264	0,0292	0,0319	0,0347	0,0374	0,0402	0,0429	S_n [m ²]
	54,29	55,15	55,72	56,13	56,43	56,67	56,85	57,00	57,13	57,24	57,33	57,41	57,48	S_n [%]
	690	860	1030	1200	1360	1530	1700	1870	2030	2200	2370	2540	2700	Q [m ³ /h]
	93	90	88	87	85	84	84	83	82	82	82	82	81	Δp [Pa]
150	0,0189	0,0242	0,0294	0,0347	0,0399	0,0452	0,0504	0,0557	0,0609	0,0662	0,0714	0,0767	0,0819	S_n [m ²]
	67,65	68,73	69,44	69,95	70,33	70,62	70,85	71,04	71,20	71,33	71,45	71,54	71,63	S_n [%]
	940	1170	1390	1610	1840	2060	2290	2510	2730	2960	3180	3410	3630	Q [m ³ /h]
	24	23	22	21	20	20	20	19	19	19	19	19	19	18
200	0,0279	0,0357	0,0434	0,0512	0,0589	0,0667	0,0744	0,0822	0,0899	0,0977	0,1054	0,1132	0,1209	S_n [m ²]
	74,13	75,31	76,09	76,65	77,06	77,38	77,63	77,84	78,01	78,16	78,29	78,39	78,49	S_n [%]
	1190	1470	1750	2030	2310	2590	2860	3140	3420	3700	3980	4260	4530	Q [m ³ /h]
	28	25	23	22	21	21	20	19	19	19	19	18	18	Δp [Pa]
250	0,0369	0,0472	0,0574	0,0677	0,0779	0,0882	0,0984	0,1087	0,1189	0,1292	0,1394	0,1497	0,1599	S_n [m ²]
	77,95	79,20	80,02	80,60	81,03	81,37	81,64	81,85	82,04	82,19	82,32	82,44	82,53	S_n [%]
	1440	1770	2100	2440	2770	3100	3430	3760	4090	4420	4750	5090	5420	Q [m ³ /h]
	21	18	16	15	14	14	13	13	12	12	12	12	11	Δp [Pa]
300	0,0459	0,0587	0,0714	0,0842	0,0969	0,1097	0,1224	0,1352	0,1479	0,1607	0,1734	0,1862	0,1989	S_n [m ²]
	80,48	81,76	82,60	83,20	83,65	84,00	84,28	84,50	84,69	84,85	84,99	85,10	85,21	S_n [%]
	1690	2070	2450	2840	3220	3600	3990	4370	4750	5130	5520	5900	6280	Q [m ³ /h]
	16	14	12	11	10	10	9	9	9	8	8	8	8	Δp [Pa]
350	0,0549	0,0702	0,0854	0,1007	0,1159	0,1312	0,1464	0,1617	0,1769	0,1922	0,2074	0,2227	0,2379	S_n [m ²]
	82,26	83,58	84,44	85,05	85,51	85,87	86,15	86,38	86,57	86,74	86,87	86,99	87,10	S_n [%]
	1930	2370	2800	3240	3670	4100	4540	4970	5400	5830	6260	6700	7130	Q [m ³ /h]
	14	11	10	9	8	8	7	7	7	6	6	6	6	Δp [Pa]
400	0,0639	0,0817	0,0994	0,1172	0,1349	0,1527	0,1704	0,1882	0,2059	0,2237	0,2414	0,2592	0,2769	S_n [m ²]
	83,60	84,93	85,81	86,43	86,90	87,26	87,55	87,78	87,98	88,14	88,28	88,41	88,51	S_n [%]
	2170	2660	3150	3630	4110	4600	5080	5560	6040	6520	7000	7480	7960	Q [m ³ /h]
	12	9	8	7	7	6	6	5	5	5	5	5	5	Δp [Pa]
450	0,0729	0,0932	0,1134	0,1337	0,1539	0,1742	0,1944	0,2147	0,2349	0,2552	0,2754	0,2957	0,3159	S_n [m ²]
	84,63	85,98	86,87	87,50	87,98	88,34	88,63	88,87	89,07	89,23	89,38	89,50	89,61	S_n [%]
	2420	2960	3490	4020	4560	5090	5620	6150	6680	7200	7730	8260	8790	Q [m ³ /h]
	10	8	7	6	6	5	5	4	4	4	4	4	4	Δp [Pa]
500	0,0819	0,1047	0,1274	0,1502	0,1729	0,1957	0,2184	0,2412	0,2639	0,2867	0,3094	0,3322	0,3549	S_n [m ²]
	85,46	86,82	87,72	88,36	88,83	89,20	89,49	89,73	89,93	90,10	90,25	90,37	90,48	S_n [%]
	2660	3250	3830	4410	4990	5570	6150	6730	7300	7880	8460	9030	9610	Q [m ³ /h]
	9	7	6	5	5	4	4	4	4	3	3	3	3	Δp [Pa]
550	0,0909	0,1162	0,1414	0,1667	0,1919	0,2172	0,2424	0,2677	0,2929	0,3182	0,3434	0,3687	0,3939	S_n [m ²]
	86,13	87,50	88,41	89,05	89,53	89,90	90,20	90,44	90,64	90,81	90,96	91,08	91,19	S_n [%]
	2900	3540	4170	4800	5430	6060	6680	7300	7930	8550	9170	9790	10420	Q [m ³ /h]
	9	7	5	5	4	4	4	3	3	3	3	3	3	Δp [Pa]
600	0,0999	0,1277	0,1554	0,1832	0,2109	0,2387	0,2664	0,2942	0,3219	0,3497	0,3774	0,4052	0,4329	S_n [m ²]
	86,69	88,07	88,99	89,63	90,11	90,49	90,79	91,03	91,23	91,40	91,55	91,68	91,79	S_n [%]
	3140	3830	4510	5190	5860	6540	7210	7880	8550	9220	9880	10550	11220	Q [m ³ /h]
	8	6	5	4	4	3	3	3	3	3	2	2	2	Δp [Pa]

Every air flow lower than the above mentioned maximum value, will meet the listed A-weighted sound power level 45dB(A), for the respective dimension.

Fire dampers

CU-LT-1s

A-weighted sound power level L_{WA} of 40 dB(A) in the duct

H/W [mm]	200	250	300	350	400	450	500	550	600	650	700	750	800	
100	0,0099	0,0127	0,0154	0,0182	0,0209	0,0237	0,0264	0,0292	0,0319	0,0347	0,0374	0,0402	0,0429	Sn [m ²]
	54,29	55,15	55,72	56,13	56,43	56,67	56,85	57,00	57,13	57,24	57,33	57,41	57,48	Sn [%]
	560	700	840	970	1110	1250	1380	1520	1650	1790	1930	2060	2200	Q [m ³ /h]
	61	60	59	57	57	56	55	55	54	54	54	54	54	Δp [Pa]
150	0,0189	0,0242	0,0294	0,0347	0,0399	0,0452	0,0504	0,0557	0,0609	0,0662	0,0714	0,0767	0,0819	Sn [m ²]
	67,65	68,73	69,44	69,95	70,33	70,62	70,85	71,04	71,20	71,33	71,45	71,54	71,63	Sn [%]
	770	950	1130	1310	1490	1680	1860	2040	2220	2400	2590	2770	2950	Q [m ³ /h]
	30	28	26	25	24	24	23	23	23	22	22	22	22	Δp [Pa]
200	0,0279	0,0357	0,0434	0,0512	0,0589	0,0667	0,0744	0,0822	0,0899	0,0977	0,1054	0,1132	0,1209	Sn [m ²]
	74,13	75,31	76,09	76,65	77,06	77,38	77,63	77,84	78,01	78,16	78,29	78,39	78,49	Sn [%]
	970	1200	1420	1650	1880	2100	2330	2550	2780	3010	3230	3460	3690	Q [m ³ /h]
	19	17	15	15	14	14	13	13	13	12	12	12	12	Δp [Pa]
250	0,0369	0,0472	0,0574	0,0677	0,0779	0,0882	0,0984	0,1087	0,1189	0,1292	0,1394	0,1497	0,1599	Sn [m ²]
	77,95	79,20	80,02	80,60	81,03	81,37	81,64	81,85	82,04	82,19	82,32	82,44	82,53	Sn [%]
	1170	1440	1710	1980	2250	2520	2790	3060	3330	3600	3870	4130	4400	Q [m ³ /h]
	14	12	11	10	9	9	9	8	8	8	8	8	8	Δp [Pa]
300	0,0459	0,0587	0,0714	0,0842	0,0969	0,1097	0,1224	0,1352	0,1479	0,1607	0,1734	0,1862	0,1989	Sn [m ²]
	96,97	98,51	99,53	100,25	100,79	101,21	101,55	101,82	102,05	102,24	102,40	102,54	102,67	Sn [%]
	1370	1680	2000	2310	2620	2930	3240	3550	3860	4170	4480	4790	5110	Q [m ³ /h]
	11	9	8	7	7	6	6	6	6	6	5	5	5	Δp [Pa]
350	0,0549	0,0702	0,0854	0,1007	0,1159	0,1312	0,1464	0,1617	0,1769	0,1922	0,2074	0,2227	0,2379	Sn [m ²]
	82,26	83,58	84,44	85,05	85,51	85,87	86,15	86,38	86,57	86,74	86,87	86,99	87,10	Sn [%]
	1570	1930	2280	2630	2980	3340	3690	4040	4390	4740	5090	5440	5790	Q [m ³ /h]
	9	7	6	6	5	5	5	5	4	4	4	4	4	Δp [Pa]
400	0,0639	0,0817	0,0994	0,1172	0,1349	0,1527	0,1704	0,1882	0,2059	0,2237	0,2414	0,2592	0,2769	Sn [m ²]
	83,60	84,93	85,81	86,43	86,90	87,26	87,55	87,78	87,98	88,14	88,28	88,41	88,51	Sn [%]
	1770	2160	2560	2950	3350	3740	4130	4520	4910	5300	5690	6080	6470	Q [m ³ /h]
	8	6	5	5	4	4	4	4	3	3	3	3	3	Δp [Pa]
450	0,0729	0,0932	0,1134	0,1337	0,1539	0,1742	0,1944	0,2147	0,2349	0,2552	0,2754	0,2957	0,3159	Sn [m ²]
	84,63	85,98	86,87	87,50	87,98	88,34	88,63	88,87	89,07	89,23	89,38	89,50	89,61	Sn [%]
	1970	2400	2840	3270	3700	4140	4570	5000	5430	5860	6290	6720	7150	Q [m ³ /h]
	7	5	5	4	4	3	3	3	3	3	3	3	2	Δp [Pa]
500	0,0819	0,1047	0,1274	0,1502	0,1729	0,1957	0,2184	0,2412	0,2639	0,2867	0,3094	0,3322	0,3549	Sn [m ²]
	85,46	86,82	87,72	88,36	88,83	89,20	89,49	89,73	89,93	90,10	90,25	90,37	90,48	Sn [%]
	2160	2640	3120	3590	4060	4530	5000	5470	5940	6410	6870	7340	7810	Q [m ³ /h]
	6	5	4	4	3	3	3	3	2	2	2	2	2	Δp [Pa]
550	0,0909	0,1162	0,1414	0,1667	0,1919	0,2172	0,2424	0,2677	0,2929	0,3182	0,3434	0,3687	0,3939	Sn [m ²]
	86,13	87,50	88,41	89,05	89,53	89,90	90,20	90,44	90,64	90,81	90,96	91,08	91,19	Sn [%]
	2360	2880	3390	3900	4410	4920	5430	5940	6440	6950	7460	7960	8470	Q [m ³ /h]
	6	4	4	3	3	3	2	2	2	2	2	2	2	Δp [Pa]
600	0,0999	0,1277	0,1554	0,1832	0,2109	0,2387	0,2664	0,2942	0,3219	0,3497	0,3774	0,4052	0,4329	Sn [m ²]
	86,69	88,07	88,99	89,63	90,11	90,49	90,79	91,03	91,23	91,40	91,55	91,68	91,79	Sn [%]
	2560	3110	3670	4220	4770	5310	5860	6400	6950	7490	8040	8580	9120	Q [m ³ /h]
	5	4	3	3	2	2	2	2	2	2	2	2	1	Δp [Pa]

Every air flow lower than the above mentioned maximum value, will meet the listed A-weighted sound power level 40dB(A), for the respective dimension.

Fire dampers

CU-LT-1s

A-weighted sound power level L_{WA} of 35 dB(A) in the duct

H/W [mm]	200	250	300	350	400	450	500	550	600	650	700	750	800	
100	0,0099	0,0127	0,0154	0,0182	0,0209	0,0237	0,0264	0,0292	0,0319	0,0347	0,0374	0,0402	0,0429	Sn [m²]
	54,29	55,15	55,72	56,13	56,43	56,67	56,85	57,00	57,13	57,24	57,33	57,41	57,48	Sn [%]
	460	570	680	790	900	1010	1120	1230	1350	1460	1570	1680	1790	Q [m³/h]
	41	40	39	38	37	37	36	36	36	36	36	36	36	Δp [Pa]
150	0,0189	0,0242	0,0294	0,0347	0,0399	0,0452	0,0504	0,0557	0,0609	0,0662	0,0714	0,0767	0,0819	Sn [m²]
	67,65	68,73	69,44	69,95	70,33	70,62	70,85	71,04	71,20	71,33	71,45	71,54	71,63	Sn [%]
	620	770	920	1070	1220	1360	1510	1660	1810	1960	2100	2250	2400	Q [m³/h]
	19	18	17	17	16	16	15	15	15	15	15	15	14	Δp [Pa]
200	0,0279	0,0357	0,0434	0,0512	0,0589	0,0667	0,0744	0,0822	0,0899	0,0977	0,1054	0,1132	0,1209	Sn [m²]
	74,13	75,31	76,09	76,65	77,06	77,38	77,63	77,84	78,01	78,16	78,29	78,39	78,49	Sn [%]
	790	970	1160	1340	1530	1710	1890	2080	2260	2450	2630	2810	3000	Q [m³/h]
	13	11	10	10	9	9	9	9	8	8	8	8	8	Δp [Pa]
250	0,0369	0,0472	0,0574	0,0677	0,0779	0,0882	0,0984	0,1087	0,1189	0,1292	0,1394	0,1497	0,1599	Sn [m²]
	77,95	79,20	80,02	80,60	81,03	81,37	81,64	81,85	82,04	82,19	82,32	82,44	82,53	Sn [%]
	950	1170	1390	1610	1830	2050	2270	2490	2710	2920	3140	3360	3580	Q [m³/h]
	9	8	7	7	6	6	6	6	5	5	5	5	5	Δp [Pa]
300	0,0459	0,0587	0,0714	0,0842	0,0969	0,1097	0,1224	0,1352	0,1479	0,1607	0,1734	0,1862	0,1989	Sn [m²]
	80,48	81,76	82,60	83,20	83,65	84,00	84,28	84,50	84,69	84,85	84,99	85,10	85,21	Sn [%]
	1120	1370	1620	1880	2130	2380	2640	2890	3140	3390	3650	3900	4150	Q [m³/h]
	7	6	5	5	5	4	4	4	4	4	4	4	3	Δp [Pa]
350	0,0549	0,0702	0,0854	0,1007	0,1159	0,1312	0,1464	0,1617	0,1769	0,1922	0,2074	0,2227	0,2379	Sn [m²]
	82,26	83,58	84,44	85,05	85,51	85,87	86,15	86,38	86,57	86,74	86,87	86,99	87,10	Sn [%]
	1280	1570	1850	2140	2430	2710	3000	3280	3570	3850	4140	4430	4710	Q [m³/h]
	6	5	4	4	4	3	3	3	3	3	3	3	3	Δp [Pa]
400	0,0639	0,0817	0,0994	0,1172	0,1349	0,1527	0,1704	0,1882	0,2059	0,2237	0,2414	0,2592	0,2769	Sn [m²]
	83,60	84,93	85,81	86,43	86,90	87,26	87,55	87,78	87,98	88,14	88,28	88,41	88,51	Sn [%]
	1440	1760	2080	2400	2720	3040	3360	3670	3990	4310	4630	4950	5260	Q [m³/h]
	5	4	4	3	3	3	3	2	2	2	2	2	2	Δp [Pa]
450	0,0729	0,0932	0,1134	0,1337	0,1539	0,1742	0,1944	0,2147	0,2349	0,2552	0,2754	0,2957	0,3159	Sn [m²]
	84,63	85,98	86,87	87,50	87,98	88,34	88,63	88,87	89,07	89,23	89,38	89,50	89,61	Sn [%]
	1600	1950	2310	2660	3010	3360	3710	4060	4410	4760	5110	5460	5810	Q [m³/h]
	5	4	3	3	2	2	2	2	2	2	2	2	2	Δp [Pa]
500	0,0819	0,1047	0,1274	0,1502	0,1729	0,1957	0,2184	0,2412	0,2639	0,2867	0,3094	0,3322	0,3549	Sn [m²]
	85,46	86,82	87,72	88,36	88,83	89,20	89,49	89,73	89,93	90,10	90,25	90,37	90,48	Sn [%]
	1760	2150	2530	2920	3300	3680	4060	4450	4830	5210	5590	5970	6350	Q [m³/h]
	4	3	3	2	2	2	2	2	2	2	1	1	1	Δp [Pa]
550	0,0909	0,1162	0,1414	0,1667	0,1919	0,2172	0,2424	0,2677	0,2929	0,3182	0,3434	0,3687	0,3939	Sn [m²]
	86,13	87,50	88,41	89,05	89,53	89,90	90,20	90,44	90,64	90,81	90,96	91,08	91,19	Sn [%]
	1920	2340	2760	3170	3590	4000	4420	4830	5240	5650	6060	6470	6880	Q [m³/h]
	4	3	2	2	2	2	2	1	1	1	1	1	1	Δp [Pa]
600	0,0999	0,1277	0,1554	0,1832	0,2109	0,2387	0,2664	0,2942	0,3219	0,3497	0,3774	0,4052	0,4329	Sn [m²]
	86,69	88,07	88,99	89,63	90,11	90,49	90,79	91,03	91,23	91,40	91,55	91,68	91,79	Sn [%]
	2080	2530	2980	3430	3880	4320	4760	5210	5650	6090	6530	6970	7410	Q [m³/h]
	4	3	2	2	2	1	1	1	1	1	1	1	1	Δp [Pa]

Every air flow lower than the above mentioned maximum value, will meet the listed A-weighted sound power level 35dB(A), for the respective dimension.



Fire dampers

CU-LT-1s

A-weighted sound power level L_{WA} of 30 dB(A) in the duct

H/W [mm]	200	250	300	350	400	450	500	550	600	650	700	750	800	
100	0,0099	0,0127	0,0154	0,0182	0,0209	0,0237	0,0264	0,0292	0,0319	0,0347	0,0374	0,0402	0,0429	Sn [m ²]
	54,29	55,15	55,72	56,13	56,43	56,67	56,85	57,00	57,13	57,24	57,33	57,41	57,48	Sn [%]
	370	460	550	640	730	820	910	1000	1090	1180	1270	1360	1450	Q [m ³ /h]
	27	26	25	25	24	24	24	24	24	24	24	24	23	Δp [Pa]
150	0,0189	0,0242	0,0294	0,0347	0,0399	0,0452	0,0504	0,0557	0,0609	0,0662	0,0714	0,0767	0,0819	Sn [m ²]
	67,65	68,73	69,44	69,95	70,33	70,62	70,85	71,04	71,20	71,33	71,45	71,54	71,63	Sn [%]
	510	630	750	870	990	1110	1230	1350	1470	1590	1710	1830	1950	Q [m ³ /h]
	13	12	11	11	11	10	10	10	10	10	10	10	10	Δp [Pa]
200	0,0279	0,0357	0,0434	0,0512	0,0589	0,0667	0,0744	0,0822	0,0899	0,0977	0,1054	0,1132	0,1209	Sn [m ²]
	74,13	75,31	76,09	76,65	77,06	77,38	77,63	77,84	78,01	78,16	78,29	78,39	78,49	Sn [%]
	640	790	940	1090	1240	1390	1540	1690	1840	1990	2140	2290	2440	Q [m ³ /h]
	8	7	7	6	6	6	6	6	6	5	5	5	5	Δp [Pa]
250	0,0369	0,0472	0,0574	0,0677	0,0779	0,0882	0,0984	0,1087	0,1189	0,1292	0,1394	0,1497	0,1599	Sn [m ²]
	77,95	79,20	80,02	80,60	81,03	81,37	81,64	81,85	82,04	82,19	82,32	82,44	82,53	Sn [%]
	780	950	1130	1310	1490	1670	1840	2020	2200	2380	2560	2730	2910	Q [m ³ /h]
	6	5	5	4	4	4	4	4	4	3	3	3	3	Δp [Pa]
300	0,0459	0,0587	0,0714	0,0842	0,0969	0,1097	0,1224	0,1352	0,1479	0,1607	0,1734	0,1862	0,1989	Sn [m ²]
	80,48	81,76	82,60	83,20	83,65	84,00	84,28	84,50	84,69	84,85	84,99	85,10	85,21	Sn [%]
	910	1110	1320	1530	1730	1940	2140	2350	2550	2760	2960	3170	3370	Q [m ³ /h]
	5	4	4	3	3	3	3	3	3	2	2	2	2	Δp [Pa]
350	0,0549	0,0702	0,0854	0,1007	0,1159	0,1312	0,1464	0,1617	0,1769	0,1922	0,2074	0,2227	0,2379	Sn [m ²]
	82,26	83,58	84,44	85,05	85,51	85,87	86,15	86,38	86,57	86,74	86,87	86,99	87,10	Sn [%]
	1040	1270	1510	1740	1970	2210	2440	2670	2900	3130	3370	3600	3830	Q [m ³ /h]
	4	3	3	3	2	2	2	2	2	2	2	2	2	Δp [Pa]
400	0,0639	0,0817	0,0994	0,1172	0,1349	0,1527	0,1704	0,1882	0,2059	0,2237	0,2414	0,2592	0,2769	Sn [m ²]
	83,60	84,93	85,81	86,43	86,90	87,26	87,55	87,78	87,98	88,14	88,28	88,41	88,51	Sn [%]
	1170	1430	1690	1950	2210	2470	2730	2990	3250	3500	3760	4020	4280	Q [m ³ /h]
	3	3	2	2	2	2	2	2	2	1	1	1	1	Δp [Pa]
450	0,0729	0,0932	0,1134	0,1337	0,1539	0,1742	0,1944	0,2147	0,2349	0,2552	0,2754	0,2957	0,3159	Sn [m ²]
	84,63	85,98	86,87	87,50	87,98	88,34	88,63	88,87	89,07	89,23	89,38	89,50	89,61	Sn [%]
	1300	1590	1880	2160	2450	2730	3020	3300	3590	3870	4150	4440	4720	Q [m ³ /h]
	3	2	2	2	2	1	1	1	1	1	1	1	1	Δp [Pa]
500	0,0819	0,1047	0,1274	0,1502	0,1729	0,1957	0,2184	0,2412	0,2639	0,2867	0,3094	0,3322	0,3549	Sn [m ²]
	85,46	86,82	87,72	88,36	88,83	89,20	89,49	89,73	89,93	90,10	90,25	90,37	90,48	Sn [%]
	1430	1750	2060	2370	2680	2990	3300	3610	3920	4230	4540	4850	5160	Q [m ³ /h]
	3	2	2	2	1	1	1	1	1	1	1	1	1	Δp [Pa]
550	0,0909	0,1162	0,1414	0,1667	0,1919	0,2172	0,2424	0,2677	0,2929	0,3182	0,3434	0,3687	0,3939	Sn [m ²]
	86,13	87,50	88,41	89,05	89,53	89,90	90,20	90,44	90,64	90,81	90,96	91,08	91,19	Sn [%]
	1560	1900	2240	2580	2920	3250	3590	3920	4260	4590	4930	5260	5600	Q [m ³ /h]
	3	2	2	1	1	1	1	1	1	1	1	1	1	Δp [Pa]
600	0,0999	0,1277	0,1554	0,1832	0,2109	0,2387	0,2664	0,2942	0,3219	0,3497	0,3774	0,4052	0,4329	Sn [m ²]
	86,69	88,07	88,99	89,63	90,11	90,49	90,79	91,03	91,23	91,40	91,55	91,68	91,79	Sn [%]
	1690	2060	2420	2790	3150	3510	3870	4230	4590	4950	5310	5670	6030	Q [m ³ /h]
	2	2	1	1	1	1	1	1	1	1	1	1	1	Δp [Pa]

Every air flow lower than the above mentioned maximum value, will meet the listed A-weighted sound power level 30dB(A), for the respective dimension.

Fire dampers

CU-LT-1s

A-weighted sound power level LWA of 25dB(A) in the duct

H/W [mm]	200	250	300	350	400	450	500	550	600	650	700	750	800	
100	0,0099	0,0127	0,0154	0,0182	0,0209	0,0237	0,0264	0,0292	0,0319	0,0347	0,0374	0,0402	0,0429	Sn [m²]
	54,29	55,15	55,72	56,13	56,43	56,67	56,85	57,00	57,13	57,24	57,33	57,41	57,48	Sn [%]
	310	380	450	520	600	670	740	820	890	960	1040	1110	1180	Q [m³/h]
	19	18	17	16	17	16	16	16	16	16	16	16	15	Δp [Pa]
150	0,0189	0,0242	0,0294	0,0347	0,0399	0,0452	0,0504	0,0557	0,0609	0,0662	0,0714	0,0767	0,0819	Sn [m²]
	67,65	68,73	69,44	69,95	70,33	70,62	70,85	71,04	71,20	71,33	71,45	71,54	71,63	Sn [%]
	410	510	610	710	810	900	1000	1100	1200	1290	1390	1490	1590	Q [m³/h]
	9	8	8	7	7	7	7	7	7	7	6	6	6	Δp [Pa]
200	0,0279	0,0357	0,0434	0,0512	0,0589	0,0667	0,0744	0,0822	0,0899	0,0977	0,1054	0,1132	0,1209	Sn [m²]
	74,13	75,31	76,09	76,65	77,06	77,38	77,63	77,84	78,01	78,16	78,29	78,39	78,49	Sn [%]
	520	640	770	890	1010	1130	1250	1370	1500	1620	1740	1860	1980	Q [m³/h]
	5	5	5	4	4	4	4	4	4	4	4	4	3	Δp [Pa]
250	0,0369	0,0472	0,0574	0,0677	0,0779	0,0882	0,0984	0,1087	0,1189	0,1292	0,1394	0,1497	0,1599	Sn [m²]
	77,95	79,20	80,02	80,60	81,03	81,37	81,64	81,85	82,04	82,19	82,32	82,44	82,53	Sn [%]
	630	780	920	1070	1210	1360	1500	1640	1790	1930	2080	2220	2370	Q [m³/h]
	4	3	3	3	3	3	2	2	2	2	2	2	2	Δp [Pa]
300	0,0459	0,0587	0,0714	0,0842	0,0969	0,1097	0,1224	0,1352	0,1479	0,1607	0,1734	0,1862	0,1989	Sn [m²]
	80,48	81,76	82,60	83,20	83,65	84,00	84,28	84,50	84,69	84,85	84,99	85,10	85,21	Sn [%]
	740	910	1070	1240	1410	1580	1740	1910	2080	2240	2410	2580	2740	Q [m³/h]
	3	3	2	2	2	2	2	2	2	2	2	2	2	Δp [Pa]
350	0,0549	0,0702	0,0854	0,1007	0,1159	0,1312	0,1464	0,1617	0,1769	0,1922	0,2074	0,2227	0,2379	Sn [m²]
	82,26	83,58	84,44	85,05	85,51	85,87	86,15	86,38	86,57	86,74	86,87	86,99	87,10	Sn [%]
	850	1040	1230	1420	1600	1790	1980	2170	2360	2550	2740	2930	3110	Q [m³/h]
	3	2	2	2	2	1	1	1	1	1	1	1	1	Δp [Pa]
400	0,0639	0,0817	0,0994	0,1172	0,1349	0,1527	0,1704	0,1882	0,2059	0,2237	0,2414	0,2592	0,2769	Sn [m²]
	83,60	84,93	85,81	86,43	86,90	87,26	87,55	87,78	87,98	88,14	88,28	88,41	88,51	Sn [%]
	950	1160	1380	1590	1800	2010	2220	2430	2640	2850	3060	3270	3480	Q [m³/h]
	2	2	2	1	1	1	1	1	1	1	1	1	1	Δp [Pa]
450	0,0729	0,0932	0,1134	0,1337	0,1539	0,1742	0,1944	0,2147	0,2349	0,2552	0,2754	0,2957	0,3159	Sn [m²]
	84,63	85,98	86,87	87,50	87,98	88,34	88,63	88,87	89,07	89,23	89,38	89,50	89,61	Sn [%]
	1060	1290	1530	1760	1990	2220	2450	2690	2920	3150	3380	3610	3840	Q [m³/h]
	2	2	1	1	1	1	1	1	1	1	1	1	1	Δp [Pa]
500	0,0819	0,1047	0,1274	0,1502	0,1729	0,1957	0,2184	0,2412	0,2639	0,2867	0,3094	0,3322	0,3549	Sn [m²]
	85,46	86,82	87,72	88,36	88,83	89,20	89,49	89,73	89,93	90,10	90,25	90,37	90,48	Sn [%]
	1160	1420	1680	1930	2180	2430	2690	2940	3190	3440	3690	3940	4200	Q [m³/h]
	2	1	1	1	1	1	1	1	1	1	1	1	1	Δp [Pa]
550	0,0909	0,1162	0,1414	0,1667	0,1919	0,2172	0,2424	0,2677	0,2929	0,3182	0,3434	0,3687	0,3939	Sn [m²]
	86,13	87,50	88,41	89,05	89,53	89,90	90,20	90,44	90,64	90,81	90,96	91,08	91,19	Sn [%]
	1270	1550	1820	2100	2370	2650	2920	3190	3460	3730	4010	4280	4550	Q [m³/h]
	2	1	1	1	1	1	1	1	1	1	1	1	0	Δp [Pa]
600	0,0999	0,1277	0,1554	0,1832	0,2109	0,2387	0,2664	0,2942	0,3219	0,3497	0,3774	0,4052	0,4329	Sn [m²]
	86,69	88,07	88,99	89,63	90,11	90,49	90,79	91,03	91,23	91,40	91,55	91,68	91,79	Sn [%]
	1380	1670	1970	2270	2560	2860	3150	3440	3730	4030	4320	4610	4900	Q [m³/h]
	2	1	1	1	1	1	1	1	1	1	0	0	0	Δp [Pa]

Every air flow lower than the above mentioned maximum value, will meet the listed A-weighted sound power level 25dB(A), for the respective dimension. Additional data can be consulted on our website.

Fire dampers

CU-LT-1s

Correction factor ΔL

To obtain the sound power level for the $L_{W \text{ oct}}$ octave midband

L_{WA} = A-weighted sound power level

ΔL = Correction factor

$L_{W \text{ oct}}$ = Sound power level for each octave midband

$$L_{W \text{ oct}} = \Delta L + L_{WA}$$

[Hz]	63	125	250	500	1000	2000	4000	8000
2 - 4 m/s	22	9	-2	-11	-18	-21	-17	-8
6 - 8 m/s	17	10	1	-4	-8	-13	-19	-21
10 - 12 m/s	15	9	0	-4	-7	-10	-14	-20

Deduct L_{WA} from the selection graph on page 360.

Fire dampers

CU-LT-1s

Operating mechanism

MFUSP: operating mechanism with fusible link

The operating mechanism MFUSP automatically unlocks the blade when the temperature in the duct exceeds 72°C.

The damper needs to be rearmed manually.

- Standard:**
- Fusible link 72° C
 - Manual unlocking possible
 - Manual rearmation, use the rearmation handle turn clockwise)
 - IP42
- Options:**
- FDCU: Unipolar begin and end of range switches

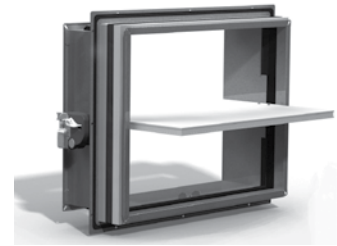

fig. CU-LT-1s + MFUSP

MMAG: upgradable automatic / remote controlled operating mechanism with fusible link

The operating mechanism MMAG automatically unlocks the blade when the temperature in the duct exceeds 72°C by sending an electrical impulse (VD) or a by interrupting the power supply (VM) to the magnet. Manual or motorized rearmation (ME MMAG).

- Standard:**
- Fusible link 72° C
 - Manual unlocking possible
 - Manual rearmation, use a rearmation handle (turn clockwise)
 - IP42
- Options:**
- Remote controlled by means of a dual voltage magnet 24/48V
- Types of magnets:**
- VD = natural magnet
 - VM = electromagnet
- FDCU : Unipolar begin and end of range switches
 - FDCB : Bipolar begin and end of range switches
 - ME : Rearmation motor

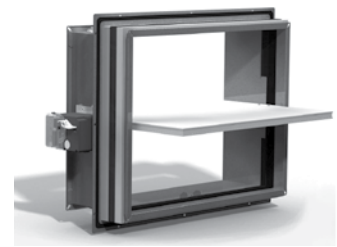

fig. CU-LT-1s + MMAG

BLF(T) : spring-return actuator (with thermo-electric fuse)

When connected to the power supply, the actuator moves the blade into its standby position (open). When the power is interrupted, an internal armed spring closes the blade (safety position).

If the motor is equipped with a thermo-electric fuse BLFT, this will interrupt the power supply when the temperature in the duct exceeds 72°C.

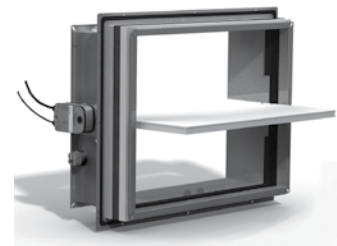







fig. CU-LT-1s + BLF(T)

Technical data

Operating mechanism	CU-LT-1s MFUSP	CU-LT-1s MMAG	CU-LT-1s BLF(T)
Description	Automatic fire damper	Upgradable automatic and remote controlled damper	Motorized remote controlled damper with spring-return actuator
Certifications	 		 
Classification	Fire resistance : - EI 120 (ve i↔o) S : range until 800 x 600 : Mounting in rigid wall min. 100 mm - EI 90 (ve i↔o) S : range until 800 x 600 : Mounting in flexible wall 120' min. 100 mm - EI 120 (ho i↔o) S : range until 800 x 600 : Mounting in rigid floor/ceiling min. 110 mm Pressure during test : 500 Pa		

- 1
- 2
- 3
- 4
- 5
- 6
- 7
- 8
- 9
- 10
- 11
- 12
- 13
- 14
- 15
- 16
- 17
- 18

Fire dampers

CU-LT-1s

Electrical connections

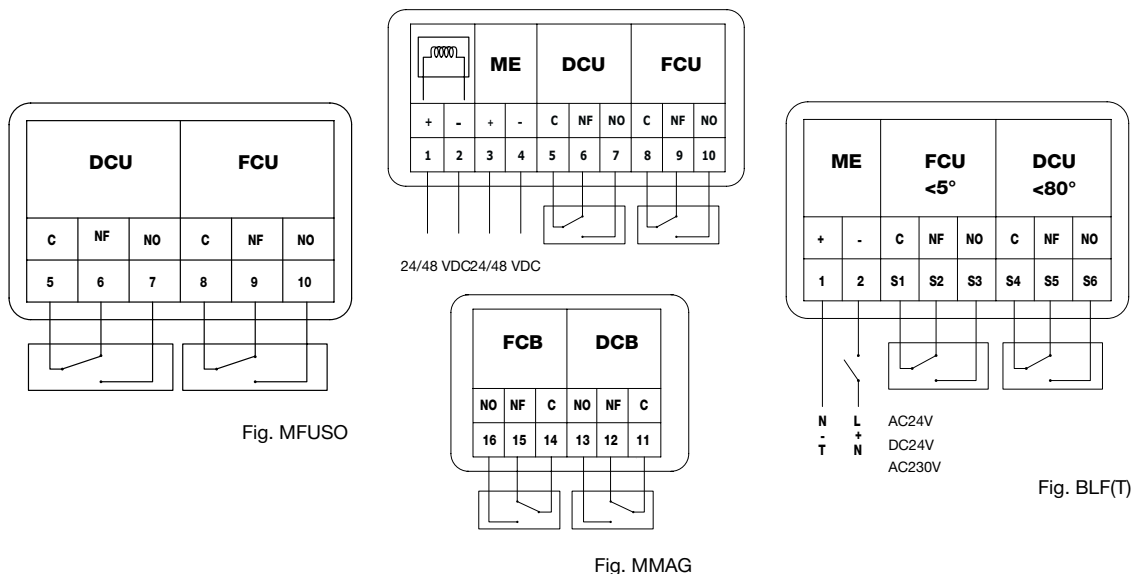

MFUSP	MMAG	BLF(T)
Power supply MFUSP	Power supply motor/ magnet MMAG	Power supply motor BLF(T)
n.a.	Rearmation motor (ME): 24/48 VDC (automatic switch) Magnet: 24/48 VDC (automatic switch)	BLF(T)24: 24VAC / 24VDC BLF(T)230: 230VAC
Power consumption	Power consumption	Power consumption
n.a. n.a. n.a.	Rearmation motor (ME): 24VDC : Pmax = 10W 48VDC : Pmax = 15W Magnet: VM: Pnom = 1,5W VD: Pmax = 3,5W	BLF(T)24: motoring: 5W holding: 2,5W BLF(T)230: motoring: 6W holding: 3W
Position switches	Position switches	Position switches
Standard: 1mA...1A, DC 5V...AC 48V	Standard: 1mA...500mA, DC 5V...AC 48V	Standard: 1mA...3A, DC 5V...AC 250V SN2: 1mA...3A, DC 5V...AC 250V
Running time	Running time	Running time
motor: n.a spring: 1s	Motor: < 30 s spring: 1s	motor: 40 ... 75s spring: 20s
Noise level	Noise level	Noise level
n.a.	Motor: max 66 DB (A)	motor: max 45 dB (A) spring: ca. 62 dB (A)
Degree of protection	Degree of protection	Degree of protection
IP 45	IP 45	IP 54

Fire dampers

CU-LT-1s

Position of the thermo-electric fuse for BLFT(T)

Height	Width	Position
≤ 300mm	= 200mm	on the side opposite to the mechanism
	> 200mm	on the W-side next to the inspection shutter
> 300mm		on the same side of the mechanism

The mechanism is always mounted on the H-side.

Standard:

- Thermo-electric fuse 72°C for BLFT
- Motorized unlocking and rearmation
- Manual rearmation possible, use the enclosed handle turn clockwise
- 24V or 230V
- Integrated unipolar begin and end of range switches
- IP 54

Options:

- SN2 Bipolar begin and end of range switches
- ST plug

1

2

3

4

5

6

7

8

9

10

11

12

13

14

15

16

17

18

Fire dampers





CU-LT-1s

Evolution kits

1		KITS MFUSP	
		Automatic operating mechanism MFUSP with fusible link 72°C	
2		KITS FUS 72 MFUS(P)	
		Fusible link 72°C for MFUS(P)	
3		KITS FDCU MFUS(P)	
		Unipolar beginning and end of range switches FDCU for MFUS(P)	
4		KITS FDCU MFUS(P)	
		Unipolar beginning and end of range switches FDCU for MFUS(P)	
5		KITS FDCU MFUS(P)	
		Unipolar beginning and end of range switches FDCU for MFUS(P)	
6		KITS MMAG	
		Upgradable operating mechanism MMAG with fusible link 72°C	
7		KITS FUS 72 MMAG	
		Fusible link 72°C for MMAG	
8		KITS FUS 72 MMAG	
		Fusible link 72°C for MMAG	
9		KITS FUS 72 MMAG	
		Fusible link 72°C for MMAG	
10		KITS VD MMAG FDCU	KITS VM MMAG FDCU
		Magnet VD24/48, VM24/48 with FDCU for MMAG	
11		KITS VD MMAG FDCU	
		Magnet VD24/48, VM24/48 with FDCU for MMAG	
12		KITS ME MMAG	
		Rearmation motor ME 24/48 for MMAG	
13		KITS ME MMAG	
		Rearmation motor ME 24/48 for MMAG	
14		KITS FDCU MMAG	
		Unipolar beginning and end of range switches FDCU for MMAG	
15		KITS FDCU MMAG	
		Unipolar beginning and end of range switches FDCU for MMAG	
16		KITS FDCU MMAG	
		Unipolar beginning and end of range switches FDCU for MMAG	
17		KITS FDCU MMAG	
		Unipolar beginning and end of range switches FDCU for MMAG	
18		KITS FDCU MMAG	
		Unipolar beginning and end of range switches FDCU for MMAG	

Fire dampers

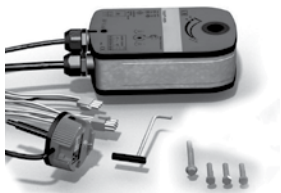
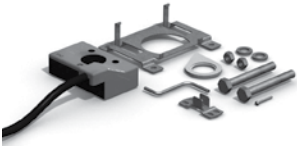
CU-LT-1s

	KITS FDCB MMAG	
	Bipolar beginning and end of range switches FDCB for MMAG	
	KITS BLF 24	KITS BLF 24-ST
	KITS BLF 230	
	Actuator Belimo BLF 24V/230V or BLF 24V with plug (ST), without thermo-electric fuse (T)	
	KITS BLFT 24	KITS BLFT 24-ST
	KITS BLFT 230	
	Actuator Belimo BLF 24V/230V or BLF 24V with plug (ST) and thermo-electric fuse (T)	
	KITS SN2 BLF	
	Bipolar beginning and end of range switches FDCB for BLF actuator	
	KITS BAE 72	
	Thermo-electric fuse 72°C (T) for Belimo BLFT 24V	

1
2
3
4
5
6
7
8
9
10
11
12
13
14
15
16
17
18

Smoke evacuation

RCJ, RCVF

Round connection with rubber sealing ring.

RCJ

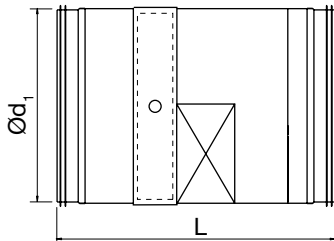

$\varnothing d_1$	L
200	447
250	487
315	497
355	487
400	527
450	527
500	517
560	517
630	527

Reducer for connection on a duct with a smaller diameter than the damper.

RCVF

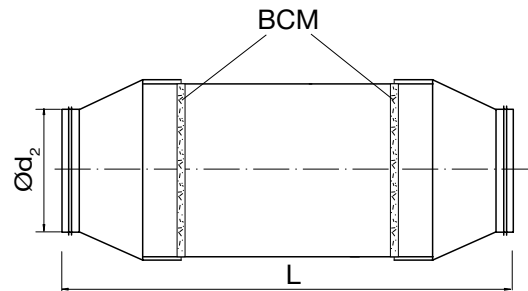
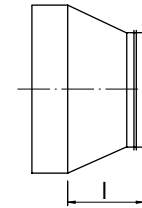

$\varnothing d_2$	$\varnothing d$	L	I
80	200	665	145
100	200	545	85
125	200	525	75
160	200	495	60
180	200	595	110
224	250	625	125

Smoke evacuation

VAN1V



Description

The “VANTAGE”-shutters are used for the smoke evacuation in residential buildings in order to facilitate a safe evacuation of people.

Standard

- locking mechanism
- connection box
- blocking
- 1 shutter [1V]
- hinge
- front frame
- gaz spring (type ceiling)

Options

- begin of range switch
- end of range switch

Ordering example

	VANTAGE 1	400	505
Product			
Width			
Height			

1V

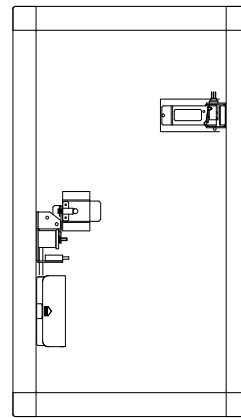

1V/P

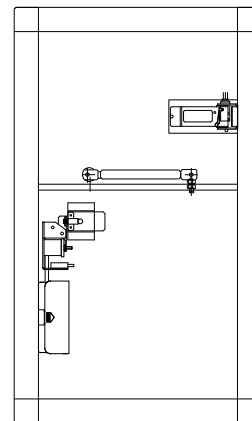

Fire resistance

Type	1h	1h 30	2h
	Finishing frame obligated		
Wall mounting	VANTAGE - 1H/2V		VANTAGE - 2H/2V
Wall mounting motorised	VANTAGE - 1H/1V/M + ME		VANTAGE - 2H/1V/M +ME
Ceiling mounting	VANTAGE - 1H/2V/P	VANTAGE - 1H30/2V/P	

- 1
- 2
- 3
- 4
- 5
- 6
- 7
- 8
- 9
- 10
- 11
- 12
- 13
- 14
- 15
- 16
- 17
- 18

Smoke evacuation

VAN1V

Installation

- Respect the top/bottom indication
- Cable-entry via a hole drilled in the refractory casing in one of the corners of the metallic front frame
- Direction of installation: mechanism on the fire-free side
- Verify the free movement of the blade

H/W [mm]	300	350	390	400	450	500	550	600
385								
415								
445								
475								
505								
535								
565								
595								
625								
655								
685								
715								
745								
775								

Reversible models

- (W+10) × (H+10)
- (W+20) × (H+20)
- CF 1h: W+60, CF 2h: W+75
- (W+45) × (H+45)
- (W+60) × (H+60)

- Installation space without build in frame
- Installation space with build in frame
- Depth opened shutter
- Ext. dimensions shutter
- Ext. dimensions grill

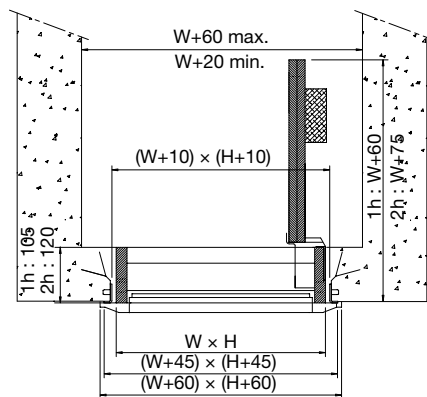
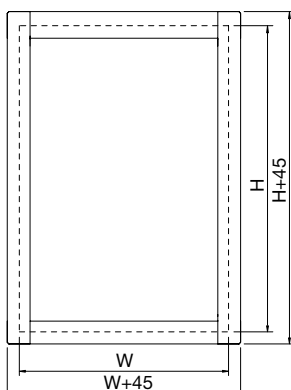

Smoke evacuation

VAN2V



Description

The “VANTAGE”-shutters are used for the smoke evacuation in residential buildings in order to facilitate a safe evacuation of people.

Standard

- centre support
- locking mechanism
- connection box
- blocking
- 2 shutters [2V]
- hinge
- front frame
- gaz springs (type ceiling)

Options

- begin of range switch
- end of range switch

Ordering example

Product	VANTAGE 1	400	505
Width			
Height			

2V

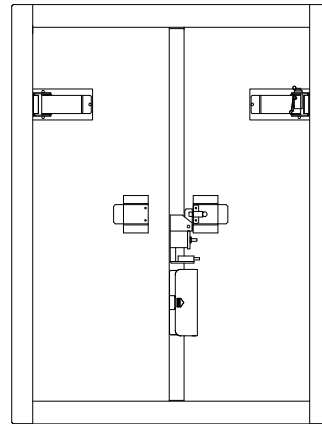

2V/P

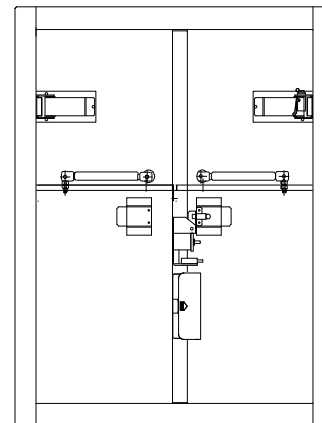

Fire resistance

Type	1h	1h30	2 h
	Finishing frame obligated		
Wall mounting	VANTAGE - 1H/2V		VANTAGE - 2H/2V
Ceiling mounting	VANTAGE - 1H/2V/P	VANTAGE - 1H30/2V/P	

- 1
- 2
- 3
- 4
- 5
- 6
- 7
- 8
- 9
- 10
- 11
- 12
- 13
- 14
- 15
- 16
- 17
- 18

Smoke evacuation

VAN2V

Installation

- Respect the top/bottom indication
- Cable-entry via a hole drilled in the refractory casing in one of the corners of the metallic front frame
- Direction of installation: mechanism on the fire-free side
- Verify the free movement of the blade

$(W+10) \times (H+10)$
 $(W+20) \times (H+20)$
 CF 1h: $W+60$, CF 2h: $W+75$
 $(W+45) \times (H+45)$
 $(W+60) \times (H+60)$

Installation space without build in frame
 Installation space with build in frame
 Depth opened shutter
 Ext. dimensions shutter
 Ext. dimensions grill

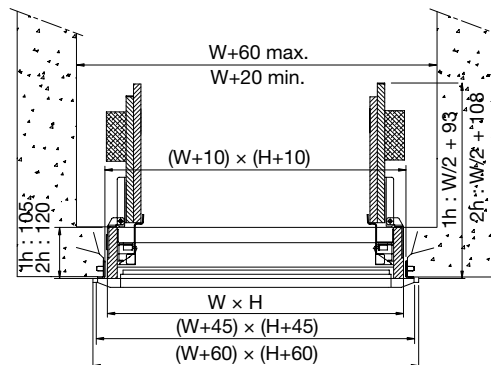
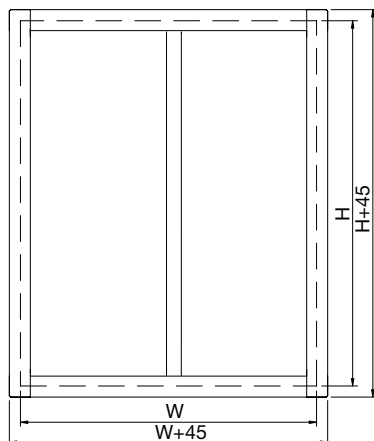

Smoke evacuation

MEC

MANF (+ME)

The unlocking mechanism MANF unlatches the smoke evacuation damper blade via remote control by sending an electric impulse (VD) or by interruption (VM) of the magnet's power supply.

By unlocking, the internal torsion spring unwinds and releases the damper blade into its safety position

To indicate the open or closed position of the fire damper blade, the mechanism is standard provided with an end and begin of range switch FDCU.

The rearmation has to be done manually (MANF).

The rearmation can be done by a remote controlled electric rearmation motor ME.

Type of magnet

VD: natural magnet

VM: electromagnet

	VM24	VM48	VD24	VD48
Voltage	24 Vdc	48 Vdc	24 Vdc	48 Vdc
Capacity	1,5 W interruption of current		3,5 W impulse of current	

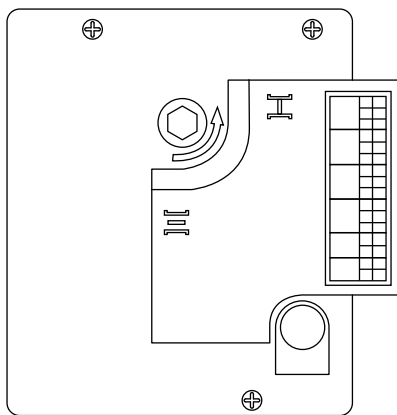

ME	FCU	DCU	FCB	DCB
+	1	1	1	1
-	2	2	2	2
+/-	3	3	3	3
~	4	4	4	4
C	5	5	5	5
NF	6	6	6	6
C	7	7	7	7
NF	8	8	8	8
C	9	9	9	9
NF	10	10	10	10
C	11	11	11	11
NF	12	12	12	12
C	13	13	13	13
NF	14	14	14	14
C	15	15	15	15
NF	16	16	16	16

Unlocking

- Manually : by pressing the yellow button
- Remote control : by an electric impulse (VD) or by interruption (VM) of the magnets power supply

Rearmation

- Manually : turn 90° with hexagon key 13 mm
A magnet with interruption (VM) needs power supply for rearmation
- By electric rearmation motor

MANF (+ME) pg C/35

Voltage	24/48 Vdc ± 10% 24/48 Vac ± 10%
I_{rms}	1A
I_{max}	± 1,5A

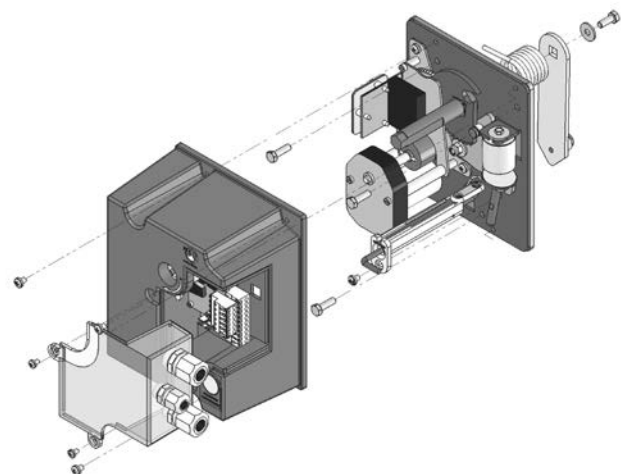

- 1
- 2
- 3
- 4
- 5
- 6
- 7
- 8
- 9
- 10
- 11
- 12
- 13
- 14
- 15
- 16
- 17
- 18

Smoke evacuation

MEC



BF – Belimo

When connected to the power supply the servomotor moves the smoke evacuation damper blade into its stand-by position.

When the power is interrupted, the internal armed spring returns the damper blade into its safety position.

	BF 24	BF 230
Voltage	24 Vdc -10% +20% 24 Vac ±20%	230 Vac ±15%
Consumption holding	2 W	3 W
Consumption rearmation	7 W	8 W
Capacity	10 VA	12,5 VA



BF24 BF230 24V 230V 	BF24-ST 24V + plug 
--	--

Option

Bipolar end and begin of range switches

SN2

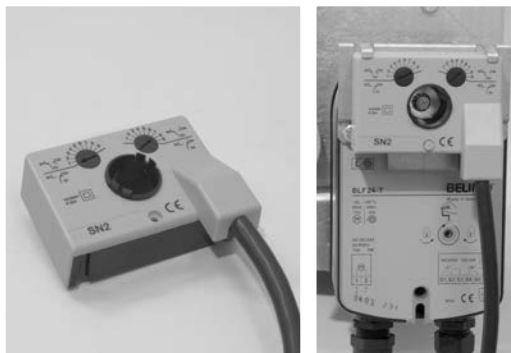

BF

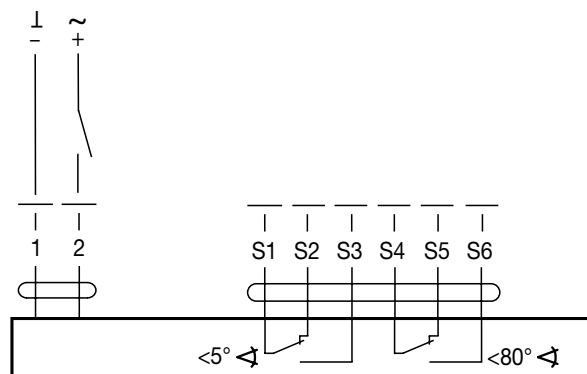

Smoke evacuation

MEC

DB – Joventa

When connected to the power supply the servomotor moves the smoke evacuation damper blade into its stand-by position.

When the power is interrupted, the internal armed spring returns the damper blade into its safety position.

	DB 24	DB 230
Voltage	24 Vdc ±10% 24 Vac ±20%	230 Vac ±10%
Consumption holding	4 W	4,5 W
Consumption rearmation	10 W	8 W
Capacity	18 VA	13 VA



DB

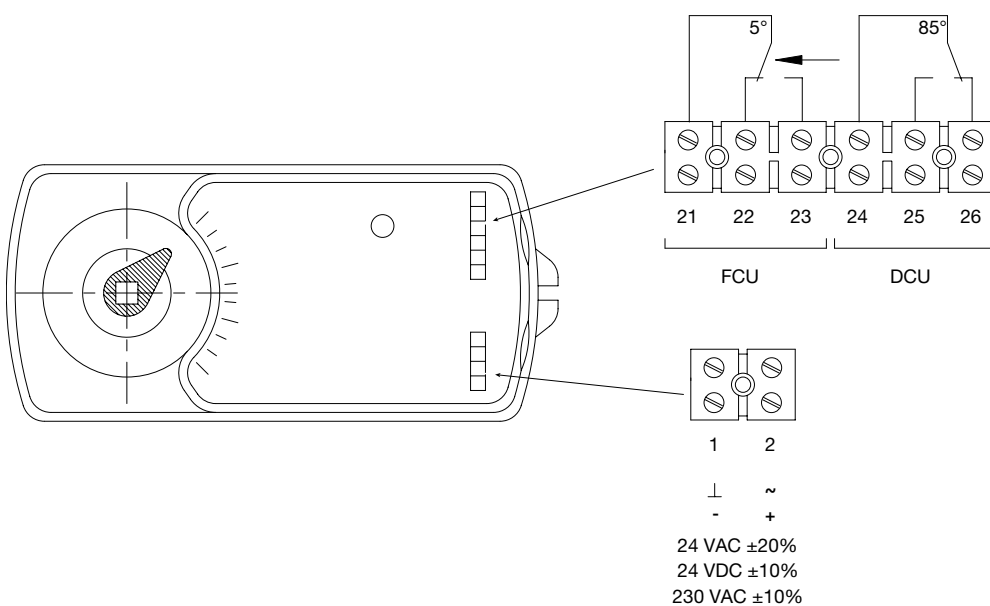

- 1
- 2
- 3
- 4
- 5
- 6
- 7
- 8
- 9
- 10
- 11
- 12
- 13
- 14
- 15
- 16
- 17
- 18

Smoke evacuation

MEC

EX – Schischek

When connected to the power supply the explosion proof motor moves the smoke evacuation damper blade into its stand-by position.

When the power is interrupted, the internal armed spring returns the damper blade into its safety position.

For deflagration risk between several risk areas are distinguished:

- Zone 1/21 :
midling risk of explosion
>100h/year explosive surroundings
- Zone 2/22 :
low risk of explosion
<10h/year of explosive surroundings



	EX 24/230
Voltage	24...230 Vac/Vdc +15%/-20%
I_{rms}	24V: 1,45A 230V: 0,3A

RMEX	EMEX
RedMax 24V/230V	ExMax 24V/230V
Zone 2/22	Zone 1/2/21/22
Explosion proof ACTUATOR for VR2/VU2	

EX

