

NEOSYS™ • 200 → 460 kW

Air cooled chiller/heat pump

NEOSYS™



Quality makes the difference*



Introduction to the range

NEOSYS™ is providing chilled and hot water for all applications with fan coils, chilled beams, air handling units, floor heating or chilled ceiling use **in office buildings, hotels, administrations, ...**

Sustainable performance

- Extended qualification tests (vibration tests, run tests, field tests) to ensure superior reliability.
- High efficiency aluminium micro channel heat exchanger (MCHX) with improved corrosion resistance for moderate marine or urban applications (Cooling only version).
- Specific MCHX coil design with high mechanical fin resistance that offers easy cleaning with high pressure air or water washers for extended life cycle.
- Compressor and hydraulic enclosure, V-coil design to protect the unit against climatic aggressions (e.g. UV light, hail).
- Exclusive Compliant Scroll® compressor design with both axial and radial compliance to increase compressor operation tolerance of liquid refrigerant, substantially improving durability and reliability.
- Exclusive fan design with hybrid ceramic bearings to maximise the service-life of motors and to reduce noise level.

Quiet performance

- Unique design with compressors, pump(s) and fan acoustic enclosure to reduce radiated noise emissions.
- Variable speed driven fans using external rotor technology associated with high performance aluminium fan blades of the latest generation.
- Elimination of intrusive fan start/stop noise that is irritating to the human ear.
- Active Acoustic Attenuation System™ (A³) to meet changing building load requirements while automatically adjusting the air flow to meet night and day sound level constraints (Time schedule with 4 time zones per day).



Start-up and service performance

- Complete hydraulic module with single or twin, low or high pressure pump (options) that includes all necessary equipment for quick connection: pump(s), regulating valve, expansion vessel with pressure gauge, pressure tapping points, water filter, air vent, pressure relief valve and victaulic connections.
- 400V, 50 Hz, 3 phases power supply (without neutral) with a single point of power connection. Main on/off switch included as standard.
- Air spring powered Butterfly electrical panel™ with top opening providing protection to service engineers against rain or snow during commissioning and maintenance operations.

Energy performance

- High Seasonal Energy Efficiency Ratio in cooling and heating mode (ESEER above 4; EER up to 2,9; COP up to 3,2) for improved energy consumption all around the year
- Aluminium micro channel heat exchanger offering outstanding system efficiency (Cooling only version).
- R410A refrigerant for optimized system performance.
- Energy savings due to lower system minimum water content buffer tank elimination reducing the time to reach setpoint.

Architectural integration

- State of the art design with hidden compressors, fans and pump for perfect architectural integration.
- Flat top, aesthetic grilles, very low unit height (< 2m) for discrete installation on a roof reducing the requirement of costly cladding solutions around the unit.

* Quality makes the difference : 3 year warranty on parts. This warranty only applies on compressors, fans, exchanger coils. Subject to LENNOX warranty policy and to maintenance contract by an accredited LENNOX company.

General data

NEOSYS™	NAC	200	230	270	300	340	380	420	480
Cooling mode									
Cooling capacity ⁽¹⁾	kW	202	229	266	299	337	377	420	460
EER ⁽²⁾		2,9	2,72	2,56	2,85	2,76	2,57	2,82	2,71
ESEER ⁽²⁾		4,18	3,97	3,93	4,11	4,09	3,92	4,48	3,95
Electrical data									
Voltage	V/Ph/Hz	400/3/50							
Refrigeration circuit									
Number of circuit	Nb	2							
Compressor	Nb	4			5			6	
Evaporator	Type	AISI 316 stainless steel plate brazed with copper heat exchanger							
Capacity steps	%	6	6	6	5	6	5	7	6
Condenser	Type	Microchannel Aluminium Tube & Fins - Air cooled							
Pressure drop									
Pressure drop ⁽¹⁾	kPa	28,6	36,6	37,5	47,2	45,3	38,6	39,2	46,9
Hydraulic connections									
Type		Victaulic							
Diameter In/Out	Inches	4"				5"			
Acoustic									
Global sound power level ⁽¹⁾	dB(A)	89	89	90	91	91	91	93	93
Operating limits									
Min. outlet water temperature	°C	5							
Max. Intlet water temperature	°C	20							
Min. difference water inlet/outlet	°C	3							
Max. difference water inlet/outlet	°C	8							
Min. outside air temperature	°C	6							
Max. outside air temperature	°C	46							

NEOSYS	NAH	200	230	270	300
Cooling mode					
Cooling capacity ⁽¹⁾	kW	191	215	271	295
EER ⁽²⁾		2,75	2,54	2,79	2,65
ESEER ⁽²⁾		4,00	3,76	3,99	3,94
Heating mode					
Heating capacity ⁽¹⁾	kW	219	252	313	346
COP		3,21	3,13	3,20	3,12
Electrical data					
Voltage	V/Ph/Hz	400/3/50			
Refrigeration circuit					
Number of circuit	Nb	2			
Compressor	Nb	4			
Evaporator	Type	AISI 316 stainless steel plate brazed with copper heat exchanger			
Capacity steps	%	6			4
Pressure drop					
Pressure drop ⁽¹⁾	kPa	25,7	32,5	38,8	46,2
Hydraulic connections					
Type		Victaulic			
Diameter In/Out	Inches	4"			
Acoustic					
Global sound power level ⁽¹⁾	dB(A)	89	89	91	91
Operating limits					
Min. Outlet water temp Cooling	°C	5			
Max. inlet water temperature	°C	20			
Min. outside air temp Cooling	°C	6			
Max. outside air temp Cooling	°C	46			
Max. Outlet water temp Heating	°C	50			
Max. Outdoor air Temp Heating	°C	-12			

(1) All data are at Eurovent condition.

(2) ESEER according to EN14511 Eurovent calculation method

Integrated hydraulic module

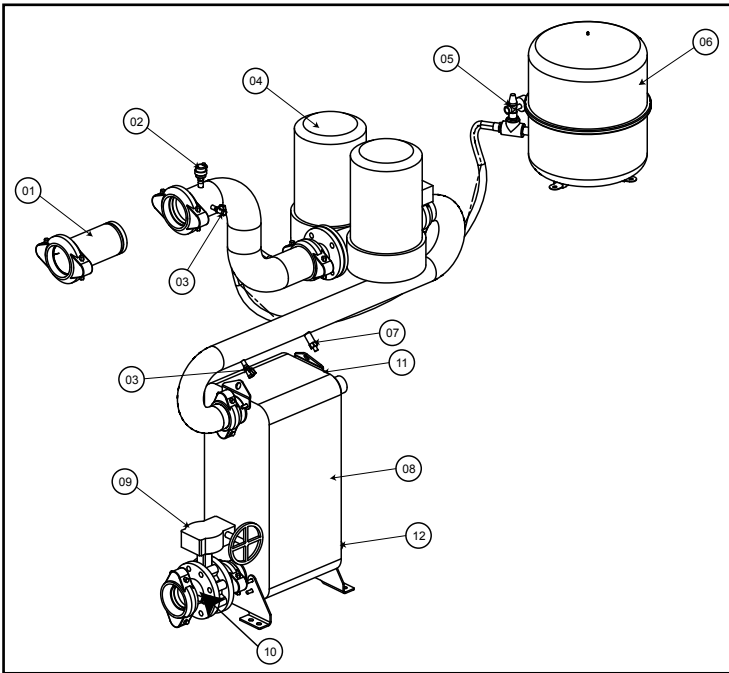

01	Water filter (supplied loose)
02	Air purge
03	Pressure tap
04	Pump
05	Safety valve with manometer
06	Expansion vessel
07	Electronic flow switch
08	Plate heat exchanger
09	Setting valve
10	Pressure tap and drain valve
11	Return temperature sensor
12	Supply temperature sensor

Pump pressure curves

Single / Double pump - Low pressure

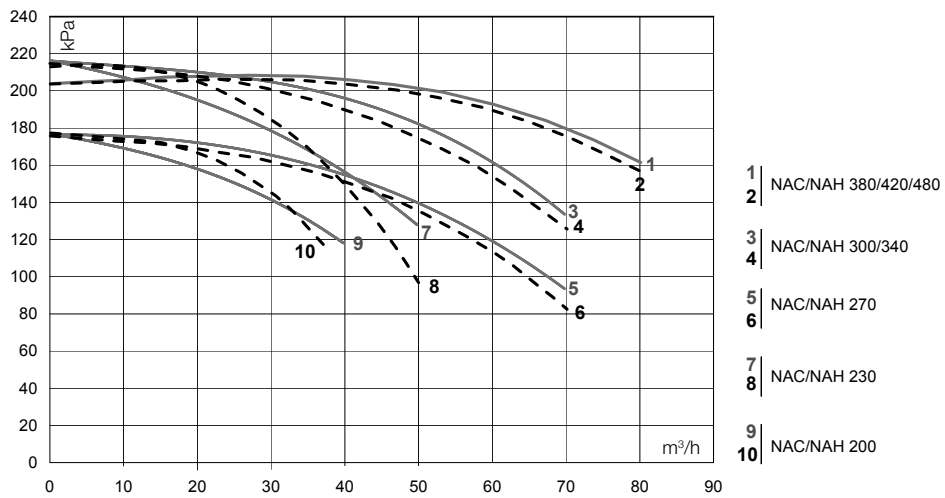

Single / Double pump - High pressure

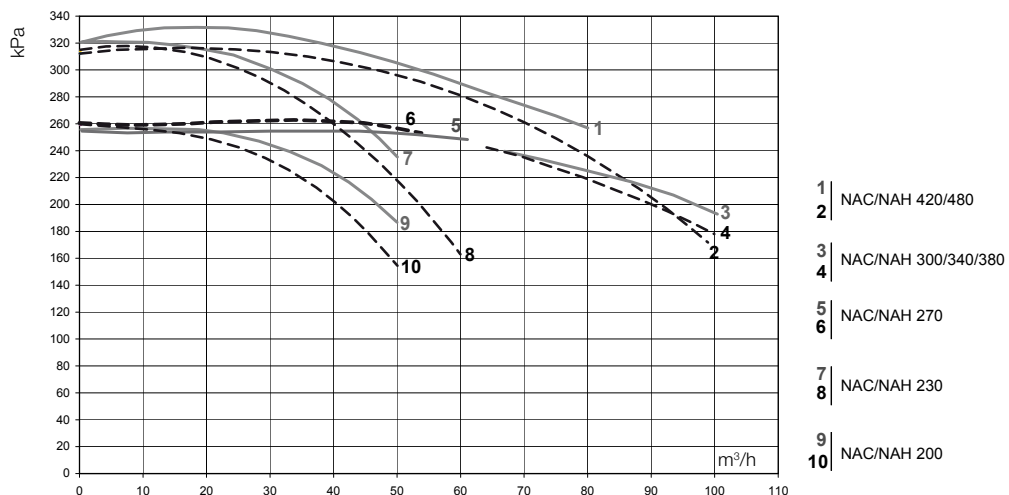

Physical data

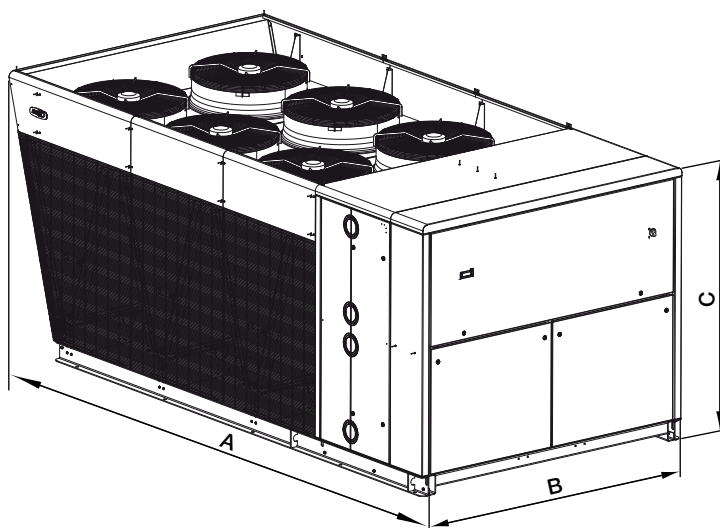

NEOSYS™	NAC	200	230	270	300	340	380	420	480
A	mm	3590	3590	3590	4620	4620	4620	5650	5650
B	mm	2280	2280	2280	2280	2280	2280	2280	2280
C	mm	1964	1964	1964	1964	1964	1964	1964	1964
Weight without water	kg	2215	2245	2465	2880	3115	3210	3760	3800

NEOSYS™	NAH	200	230	270	300
A	mm	3590	3590	4620	4620
B	mm	2280	2280	2280	2280
C	mm	1964	1964	1964	1964
Weight without water	kg	Please consult us			

Options

- Rear coil guard
- Heavy anti-corrosion coil treatment
- Anti-freeze protection
- Soft-starter
- Power factor correction
- Winter cooling operation down to -10°C
- Brine operation down to -10°C
- Hydraulic module with low-pressure single pump
- Hydraulic module with low-pressure twin pump
- Hydraulic module with high-pressure single pump
- Hydraulic module with high-pressure twin pump
- Water filter (supplied loose)
- Victaulic connection sleeve (supplied loose)
- DC50™ remote comfort display (supplied loose)
- DS50™ service display (supplied loose)
- Modbus communication interface
- LonWorks® communication interface
- Bacnet® communication interface
- Adalink™ supervision (available during 2008)
- BE 50 extension board for additional I/O
- Anti-vibration mounts

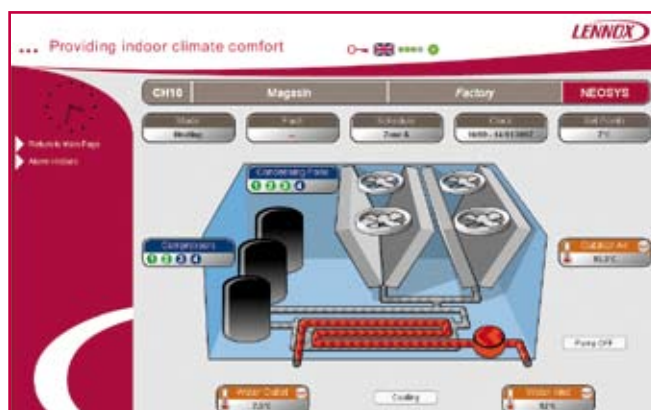

ADALINK™ supervision