



BURNERS

BRUCIATORI

All purpose heating solutions
Soluzioni integrate per il riscaldamento

FBR Quality System Certified UNI EN ISO 9001

Azienda Certificata con Sistema Qualità Aziendale UNI EN ISO 9001

INTRODUCTION
INTRODUZIONE

_ 4

**FBR – TECHNOLOGICAL RIGOR
AND ECOLOGICAL RESPECT**

F.B.R.'s first aim has always been research of the best in technology. Our products are only marketed after stringent trials using the latest in industry led testing procedures with respect and consideration given to any issue relating to the ecological and environmental impact. F.B.R. is qualified by the Quality Management System ISO 9001 and all our products are certified and conform to the current CE norms.

**FBR – RIGORE TECNOLOGICO
E RISPETTO ECOLOGICO**

Ricerca il meglio tecnologico è il nostro impegno da sempre. I prodotti F.B.R. nascono da costanti verifiche, rigorose e d'avanguardia, ponendo particolare attenzione alle tematiche del rispetto ecologico e dell'impatto ambientale. I nostri prodotti sono conformi e certificati secondo le vigenti norme CE e la nostra azienda è certificata con il Sistema Qualità ISO 9001.

INDEX
INDICE

1.LIGHT OIL BURNERS
BRUCIATORI DI GASOLIO

_ 8

2.HEAVY OIL BURNERS
BRUCIATORI DI OLIO COMBUSTIBILE

_ 18

3.GAS BURNERS
BRUCIATORI DI GAS

_ 26

4.DUAL FUEL BURNERS
GAS/LIGHT OIL
GAS/HEAVY OIL KN
BRUCIATORI MISTI
GAS/GASOLIO
GAS/OLIO COMBUSTIBILE KN

_ 38

_ 44

5.INDUSTRIAL BURNERS
BRUCIATORI INDUSTRIALI

_ 46



Capturing the fire to free heat

Catturiamo il fuoco
per liberare calore



Knowledge and updating
at FBR Training Centre



100% MADE in ITALY

Since 1969 HIGH-TECH burners

We are the right partner for the distributor with Quality as absolute value.

Since 1969 we have designed and manufactured high-tech burners for industrial and civil applications. In addition to the standard product range, F.B.R. also supplies high power burners and burners for alternative fuels such as biodiesel, "BTZ" (low sulfur oil) and vegetable oils (i.e. colza oil, sunflower oil).

FBR's sound experience together with an open and innovative spirit results in our products being appreciated on the principal international markets: currently our burners are distributed to 80 nations throughout the world.

The diffusion of knowledge with its continuous updating is guaranteed through specific training courses held by our qualified technicians within our own F.B.R. Training Centre.

Siamo il partner ideale degli Installatori che puntano alla Qualità come valore assoluto.

Dal 1969 progettiamo e costruiamo bruciatori ad alto contenuto tecnologico per applicazioni industriali e civili. Oltre alle realizzazioni standard qui presentate, FBR può fornire versioni speciali quali bruciatori di grandi potenzialità e bruciatori per combustibili alternativi di Biodiesel, BTZ (basso tenore di zolfo) e oli di origine vegetale (come olio di colza, olio di semi di girasole).

La consolidata esperienza F.B.R. unita ad uno spirito aperto e innovativo ci hanno permesso di fare apprezzare i nostri prodotti sui principali mercati internazionali: la distribuzione dei nostri bruciatori interessa ad oggi 80 nazioni nel mondo.

La diffusione delle competenze e il continuo aggiornamento sono garantiti attraverso corsi di formazione specialistici, tenuti dai nostri tecnici qualificati presso il Centro di Formazione interno F.B.R, rivolti agli Operatori del settore.

80 nations all over the world



Our job is to focus on your requirements

Mettere a fuoco le vostre esigenze è il nostro lavoro



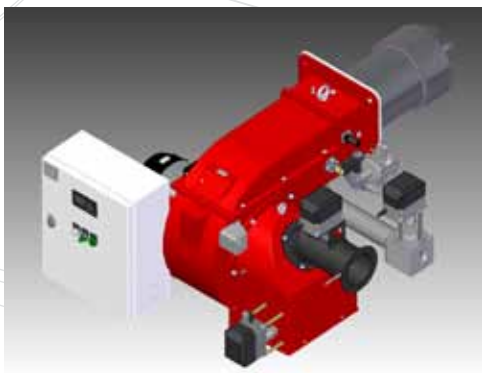

Ultra Low NOx FGR

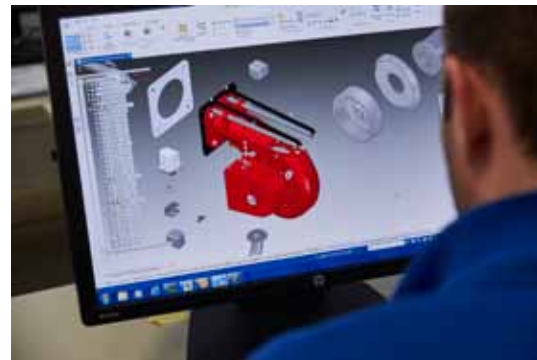

FBR R&D Lab

always looking for better performance

FBR combustion and electronics experts are fully dedicated to the analysis and implementation of new technological solutions that guarantee excellence in performances and reliability.

Our Research & Development team is constantly looking to better performance using the very latest in three dimensional CAD systems and a fully equipped laboratory together with a hi-tech simulated working environment. Particularly the laboratory of research & development is equipped with precise electronic paramagnetic infrared and ultraviolet devices of combustion analysis, digital multiscale phonometries, an evolved oscilloscope interfaced to a computerized data collecting system and integrated and multifunctional tools for performance analysis and long duration testing.

Il team di esperti FBR nella combustione e nell'elettronica è dedicato a tempo pieno all'analisi ed all'implementazione di nuove soluzioni tecnologiche che garantiscano l'eccellenza in termini di prestazioni e di affidabilità.

Nella ricerca delle migliori prestazioni il nostro team si avvale di strumentazioni costantemente aggiornate quali il sistema CAD tridimensionale, l'ampio e attrezzato laboratorio di ricerca e le sale di prova attrezzate per simulare le più difficili condizioni di funzionamento. In particolare, il laboratorio di ricerca e sviluppo è dotato di precisi dispositivi elettronici di analisi di combustione paramagnetici ad infrarossi e ultravioletti, di fonometri digitali multiscala, di un evoluto oscilloscopio interfacciato ad un sistema computerizzato di rilevazione dati e di strumenti integrati e multifunzionali per verifiche ed analisi di performance e test di lunga durata.

Customized design

At FBR a consolidated team of technicians and designers is committed day after day to turn the most demanding requirements and unexpressed needs into concrete and innovative projects. Listening to the Client and proposing new solutions: on this premise we develop the accurate designing of products to be even more reliable and up-to-date.

In FBR un consolidato team di tecnici-progettisti è impegnato giorno dopo giorno a trasformare le richieste più esigenti e le necessità inesprese in progetti concreti e innovativi. Ascoltare il Cliente e proporre nuove soluzioni: su queste premesse si sviluppa l'accurata progettazione di prodotti sempre più affidabili e d'avanguardia.



LIGHT OIL BURNERS

BRUCIATORI DI GASOLIO

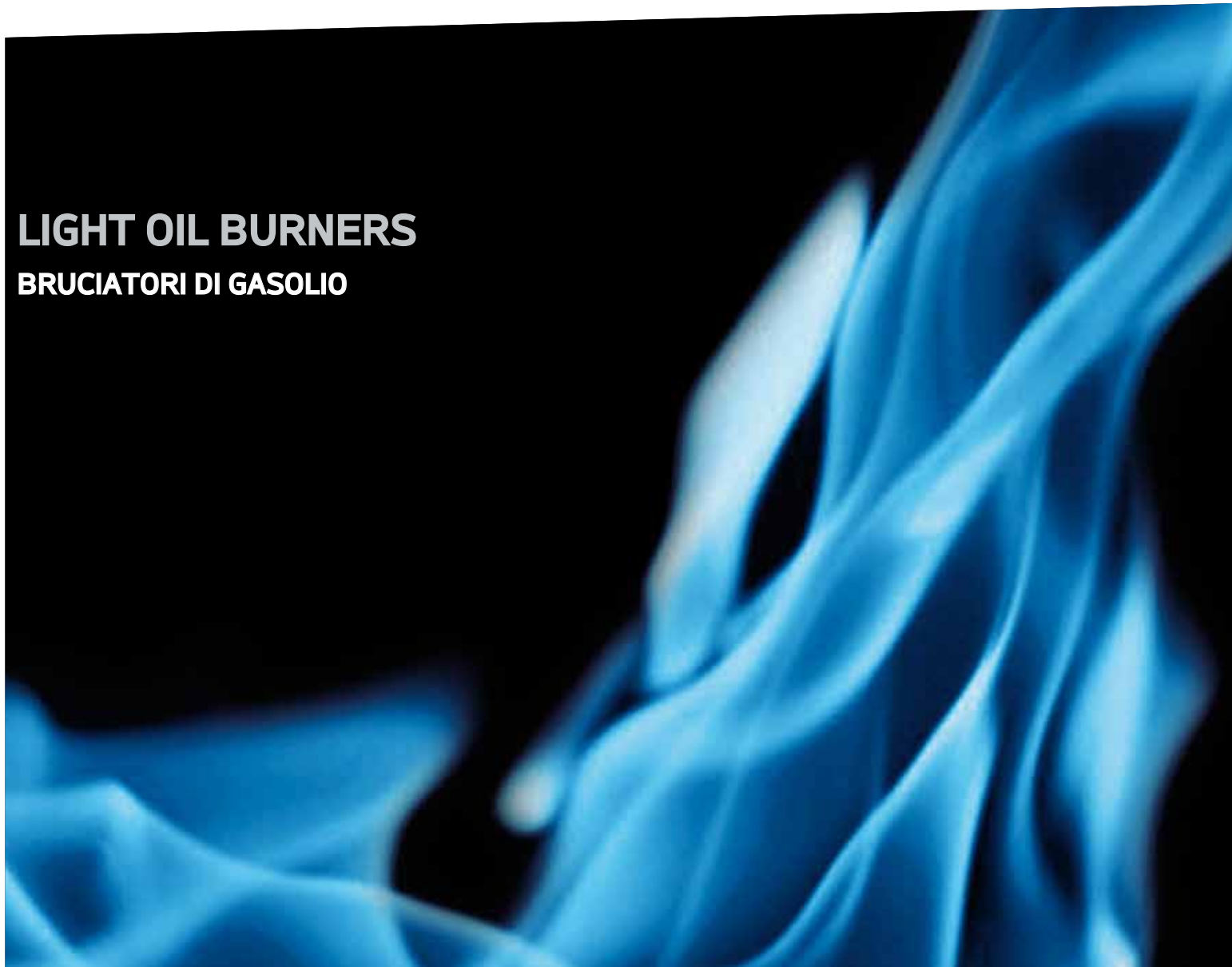



1 STAGE MONOSTADIO	kg/h		kW		⚡
	min	max	min	max	
G 0S 2001/2003* - G 0H 2001	2	3,3	23,7	39,1	1F
G 0SR 2001/2003* - G 0HR 2001	1,2	3,1	14,2	36,7	
G 1S 2001/2003* - G 1H 2001 - G 1R 2001/2003*	2	5	23,7	59,3	
G 2S MAXI* - G 2H MAXI	4	9,8	47,4	116	
G X3S - G X3H	7	15	83	178	
G X4S - G X4H	10	20	118	237	
G X5S - G X5H	12	30	142	356	

* Available also in Low NOx version
* Disponibili anche in versione Low NOx

FIRING RATES / OVERALL DIMENSIONS (mm) - CAMPO DI LAVORO / DIMENSIONI (mm)

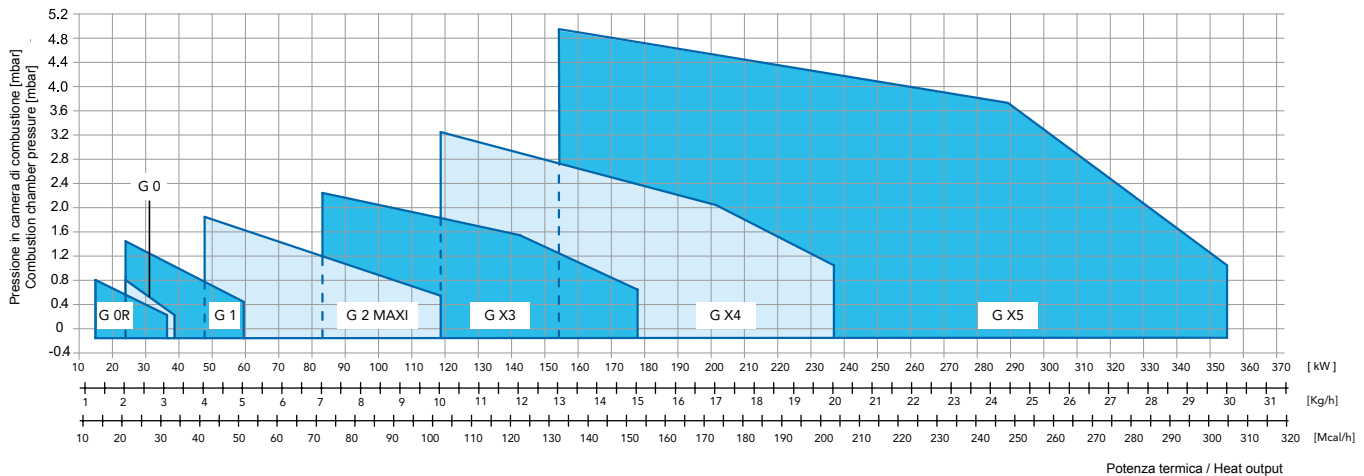
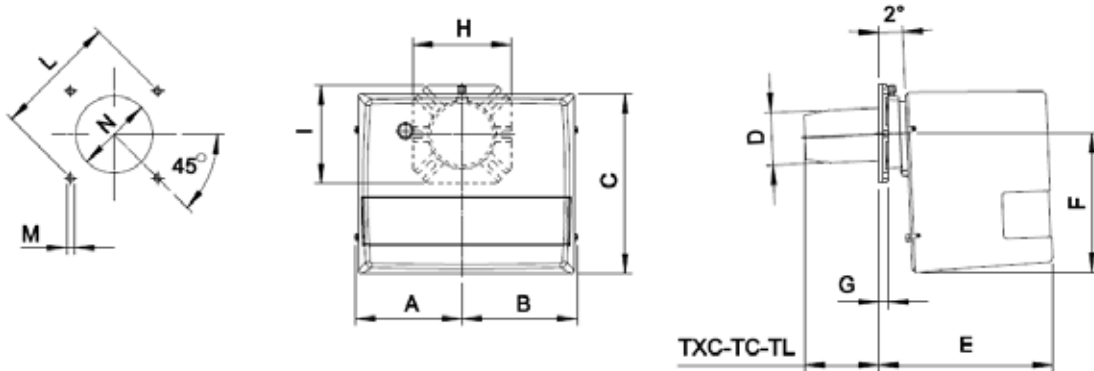

* Suggested/Consigliato
** TXC = 77

MODEL MODELLO	A	B	C	D	E	F	G	H	I	L min	L *	L max	M	N min	N *	N max	TC	TL
G 0... 2001	137	137	240	80	223	169	15	150	150	130	150	170	M8	90	110	130	112	152
G 0...2003 **	137	137	240	83	223	169	15	150	150	130	150	170	M8	90	110	130	112	152
G 1... 2001	157	170	275	80	265	210	15	150	150	130	150	170	M8	90	110	130	112	152
G 1...2003	157	170	275	83	265	210	15	150	150	130	150	170	M8	90	110	130	112	152
G 2...MAXI	157	170	275	90	265	210	15	150	150	130	150	170	M8	100	110	130	107	147
G X3...	182	192	318	110	306	248	17	200	200	160	170	226	M10	120	130	140	130	250
G X4...	182	192	318	124	306	248	17	200	200	170	205	226	M10	130	140	160	130	250
G X5...	210	218	400	130	461	310	18	200	200	205	220	226	M10	140	150	180	215	335



2 STAGES WITH JUMP OF PRESSURE BISTADIO A SALTO DI PRESSIONE	kg/h		kW		1F
	min	max	min	max	
G 1.22 2001	2	5	23,7	59,3	
G 2.22 MAXI*	4	9,8	47,4	116	
G X 3.22	7	15	83	178	
G X 4.22	10	20	118	237	
G X 5.22	12	30	142	356	

* Available also in Low NOx version
* Disponibili anche in versione Low NOx

FIRING RATES / OVERALL DIMENSIONS (mm) - CAMPO DI LAVORO / DIMENSIONI (mm)

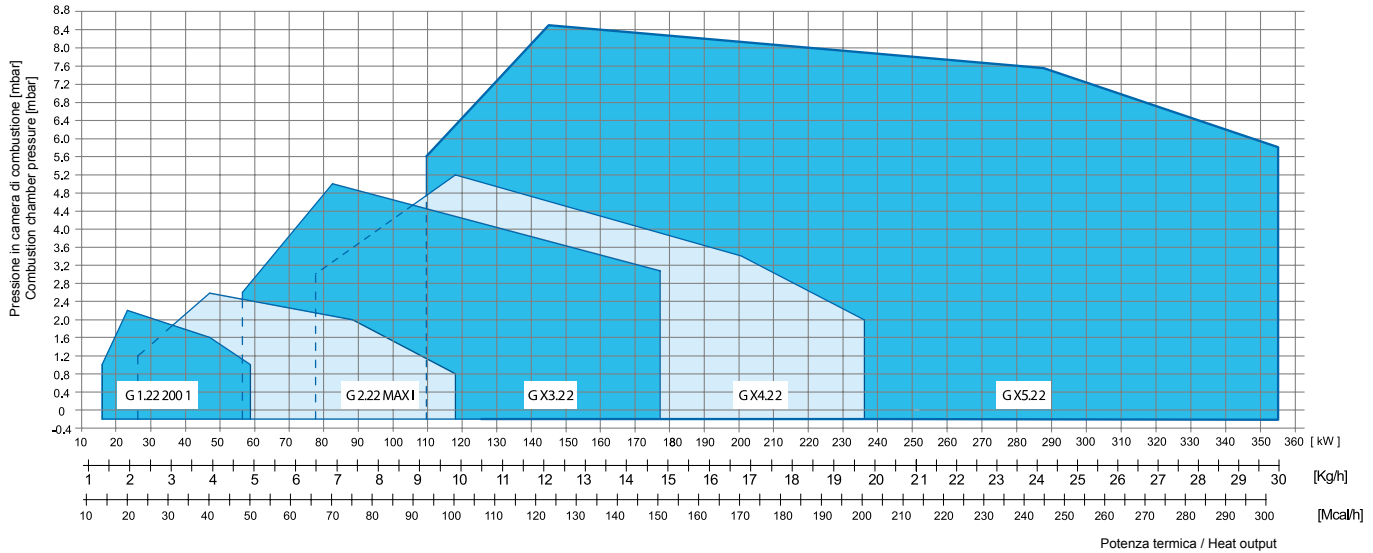
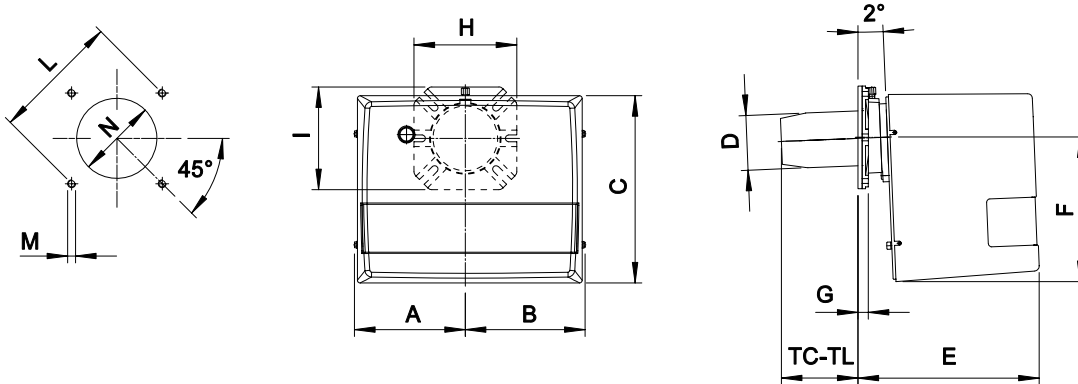

MODEL MODELLO	A	B	C	D	E	F	G	H	I	L min	L*	L max	M	N min	N*	N max	TC	TL
G 1.22 2001	157	170	275	80	265	210	15	150	150	130	150	170	M8	90	110	130	112	152
G 2.22 MAXI	157	170	275	90	265	210	15	150	150	130	150	170	M8	100	110	130	107	147
G X 3.22	182	192	318	110	306	248	17	200	200	160	170	226	M10	120	130	140	130	250
G X 4.22	182	192	318	124	306	248	17	200	200	170	205	226	M10	130	140	160	130	250
G X 5.22	210	218	400	130	461	310	18	200	200	205	220	226	M10	140	150	180	215	335

* Suggested/Consigliato



1 STAGE for bakery ovens MONOSTADIO per forni da pane	kg/h		kW		1F
	min	max	min	max	
G 1F 2001	2	5	23,7	59,3	
G 2F MAXI	4	9,8	47,4	116	
G X3 F	7	15	83	178	
G X4 F	10	20	118	237	
G X5 F	12	30	142	356	

FIRING RATES / OVERALL DIMENSIONS (mm) - CAMPO DI LAVORO / DIMENSIONI (mm)

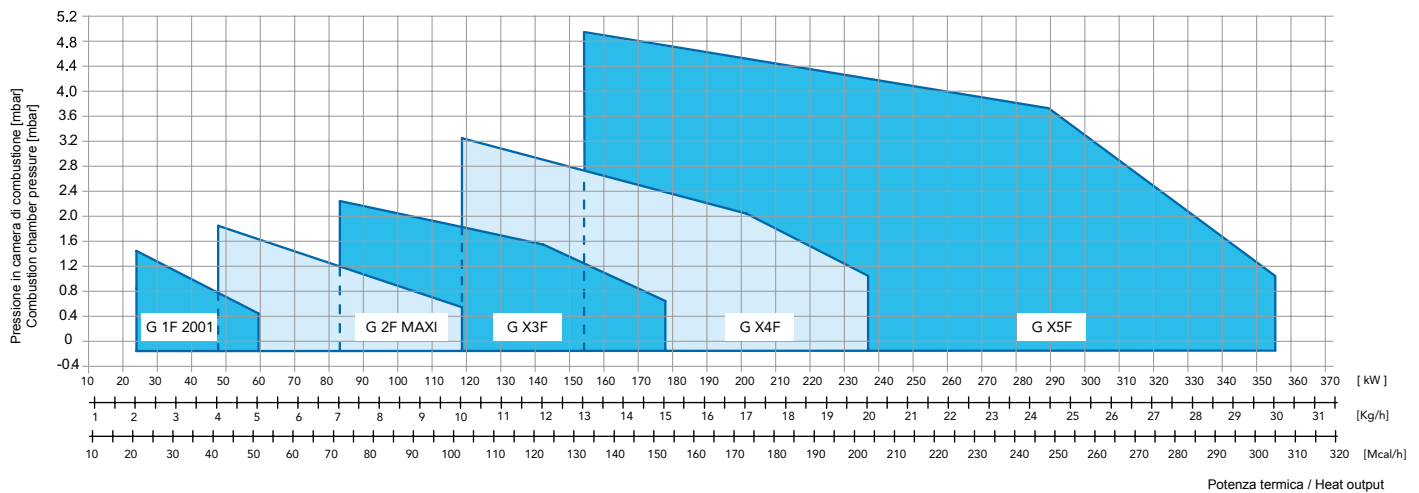
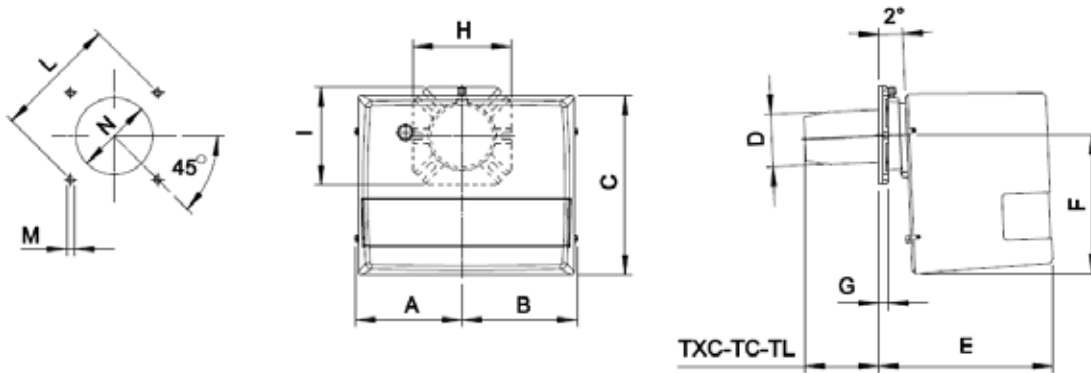

MODEL MODELLO	A	B	C	D	E	F	G	H	I	L min	L *	L max	M	N min	N *	N max	TC	TL
G 1F	157	170	275	80	265	210	15	150	150	130	150	170	M8	90	110	130	112	152
G 2 F MAXI	157	170	275	90	265	210	15	150	150	130	150	170	M8	100	110	130	107	147
G X3 F	182	192	318	110	306	248	17	200	200	160	170	226	M10	120	130	140	130	250
G X4 F	182	192	318	124	306	248	17	200	200	170	205	226	M10	130	140	160	130	250
G X5 F	210	218	400	130	461	310	18	200	200	205	220	226	M10	140	150	180	215	335

* Suggested/Consigliato



2 STAGES BISTADIO	kg/h		kW		1F
	min	max	min	max	
GX 4/2	8/12	25	94,9/142	296	1F
GX 5/2	8,5/15	35	101/178	415	

FIRING RATES / OVERALL DIMENSIONS (mm) - CAMPO DI LAVORO / DIMENSIONI (mm)

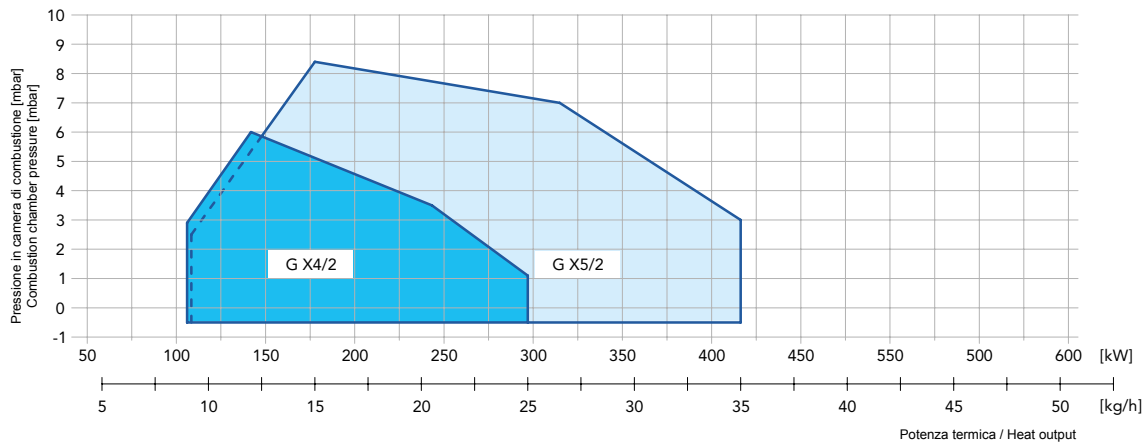
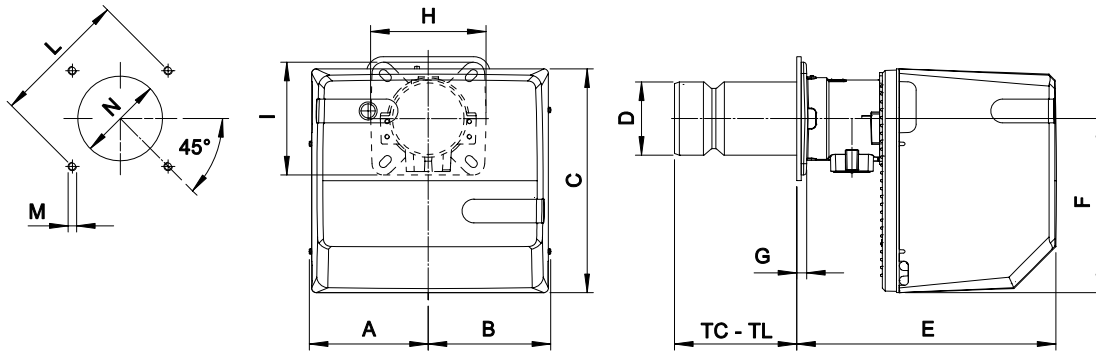

MODEL MODELLO	* Suggested/Consigliato																	
	A	B	C	D	E	F	G	H	I	L min	L*	L max	M	N min	N*	N max	TC	TL
GX 4/2	182	192	318	124	306	248	17	200	200	170	205	226	M10	130	140	160	130	250
GX 5/2	210	218	400	130	461	310	18	200	200	205	220	226	M10	140	150	180	215	335



2 STAGES BISTADIO	kg/h		kW		⚡
	min	max	min	max	
FGP 50/2	10,5/20	50	124/237	593	3F
FGP 70/2	18/35	70	213/415	830	
FGP 100/2	20,5/40	100	243/474	1186	
FGP 120/2	29/60	120	344/712	1423	
FGP 150/2	38,5/75	150	457/889	1744	

FIRING RATES / OVERALL DIMENSIONS (mm) - CAMPO DI LAVORO / DIMENSIONI (mm)

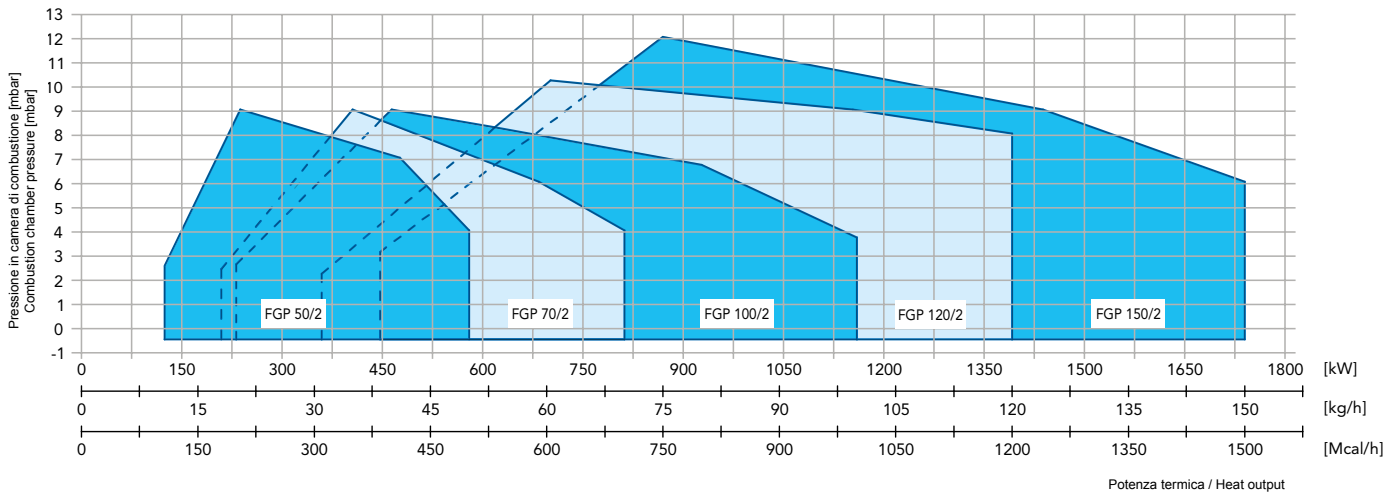
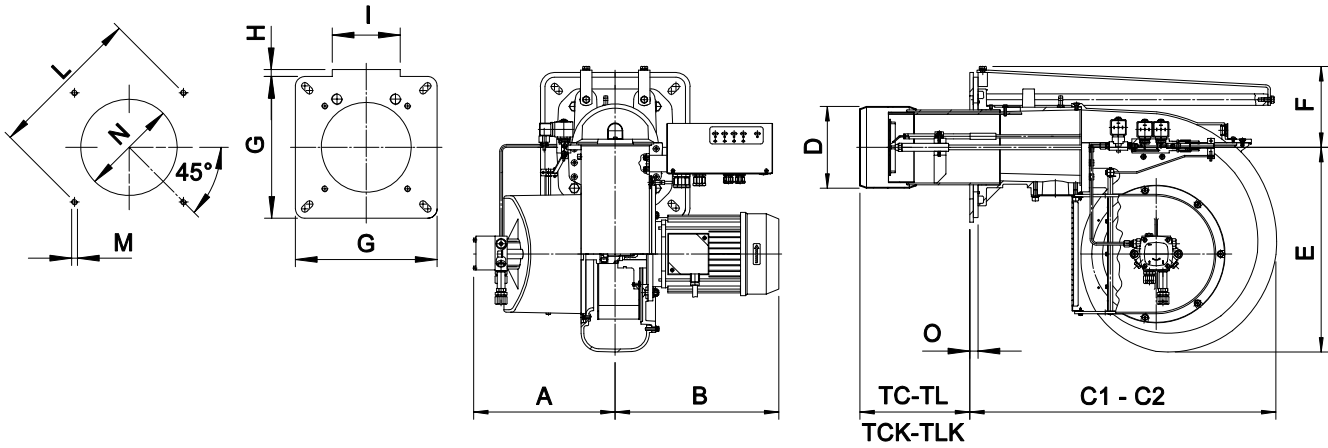

* Suggested/Consigliato

MODEL MODELLO	A	B	C1	C2	D	E	F	G	H	I	L min	L max	M	N min*	N max	O	TC	TL
FGP 50/2	188	324	493	-	150	327	100	200	0	0	205	226	M10	160	180	18	250	335
FGP 70/2	250	310	660	1060	165	327	171	300	10	144	310	368	M12	180	250	18	250	335
FGP 100/2	300	350	670	1170	175	438	173	300	0	0	340	368	M12	190	250	18	235	370
FGP 120/2	350	380	820	1400	212	438	213	320	40	183	340	368	M14	230	250	23	200	400
FGP 150/2	350	380	820	1400	212	438	213	320	40	183	340	367	M14	230	250	23	200	400

C2= overall dimension with the burner out in position of maintenance
C2= ingombro a bruciatore arretrato in posizione di manutenzione



PROGRESSIVE & MODULATING PROGRESSIVI E MODULANTI	kg/h		kW		⚡
	min	max	min	max	
FGP 50/M	10,5/20	50	124/237	593	3F
FGP 70/M	18/35	70	213/415	830	
FGP 100/M	20,5/40	100	243/474	1186	
FGP 120/M	29/60	120	344/712	1423	
FGP 150/M	38,5/75	150	457/889	1744	

FIRING RATES / OVERALL DIMENSIONS (mm) - CAMPO DI LAVORO / DIMENSIONI (mm)

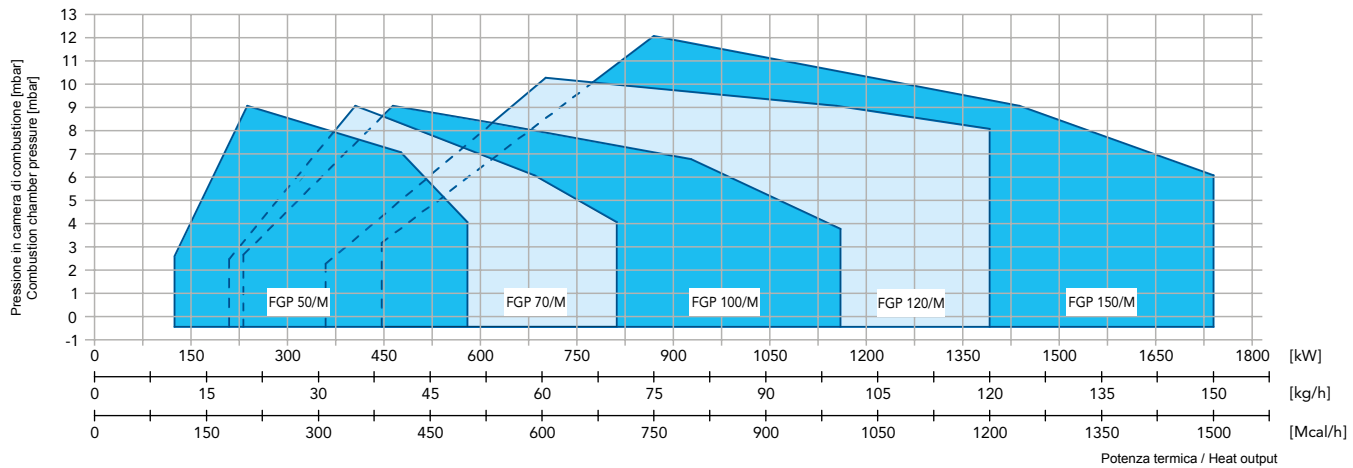
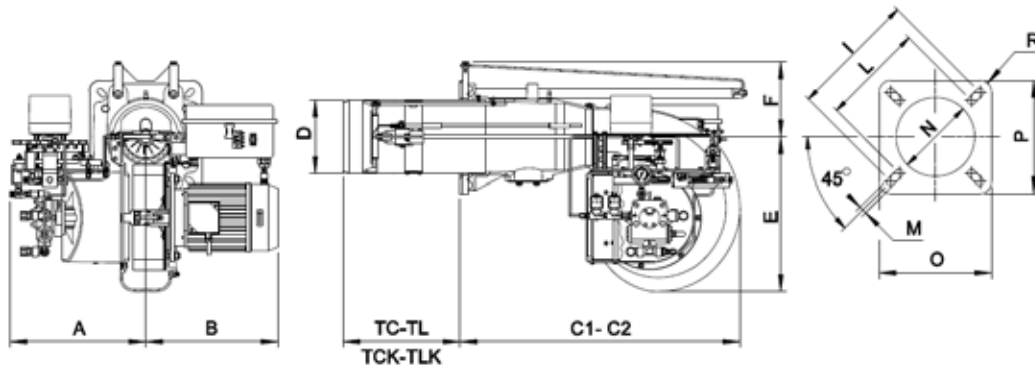

MODEL MODELLO	A	B	C1	C2	D	E	F	I	L	M	N	O	P	R	TC	TL
FGP 50/M	350	305	530	-	150	327	145	226	205	M10	160	220	220	R30	250	335
FGP 70/M	350	310	700	1140	165	327	171	368	340	M12	180	320	320	R20	250	335
FGP 100/M	386	375	651	1150	175	438	173	368	340	M12	190	320	320	R20	235	370
FGP 120/M	386	376	815	1395	209	438	213	368	340	M14	230	320	320	R20	200	400
FGP 150/M	386	397	815	1395	209	438	213	368	340	M14	230	320	320	R20	200	400

C2= overall dimension with the burner out in position of maintenance
C2= ingombro a bruciatore arretrato in posizione di manutenzione



3 STAGES TRISTADIO	kg/h		kW		⚡
	min	max	min	max	
FGP 190/3	22/60	206	255/712	2443	3F
FGP 250/3	27/80	250	313/949	2965	
FGP 350/3	49/140	350	568/1660	4151	
FGP 450/3	55/160	450	638/1898	5337	

FIRING RATES / OVERALL DIMENSIONS (mm) - CAMPO DI LAVORO / DIMENSIONI (mm)

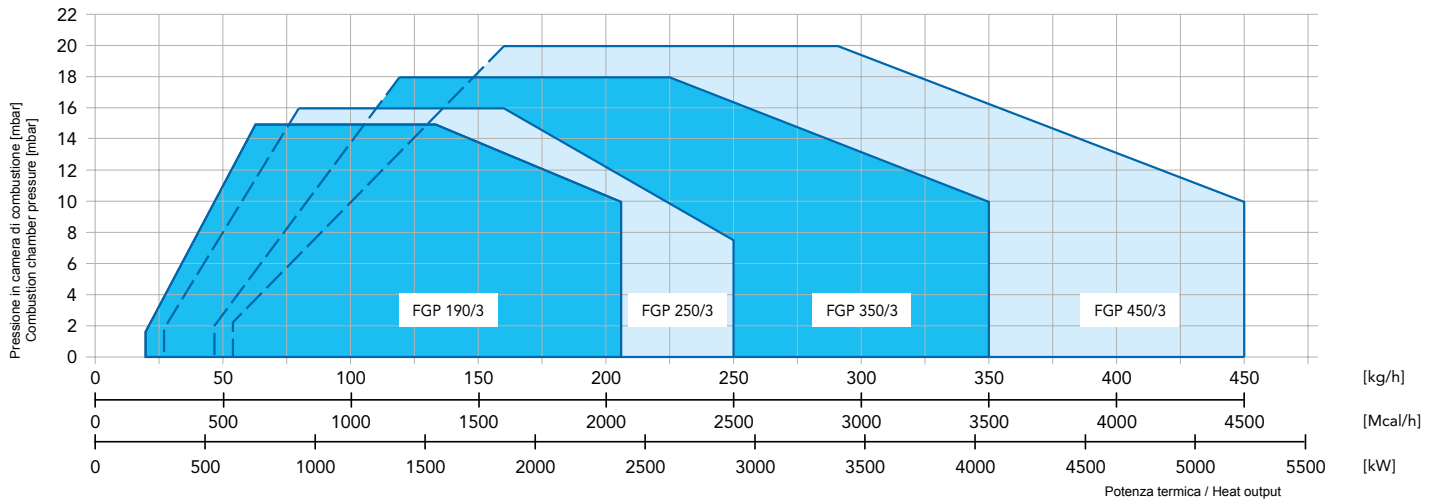
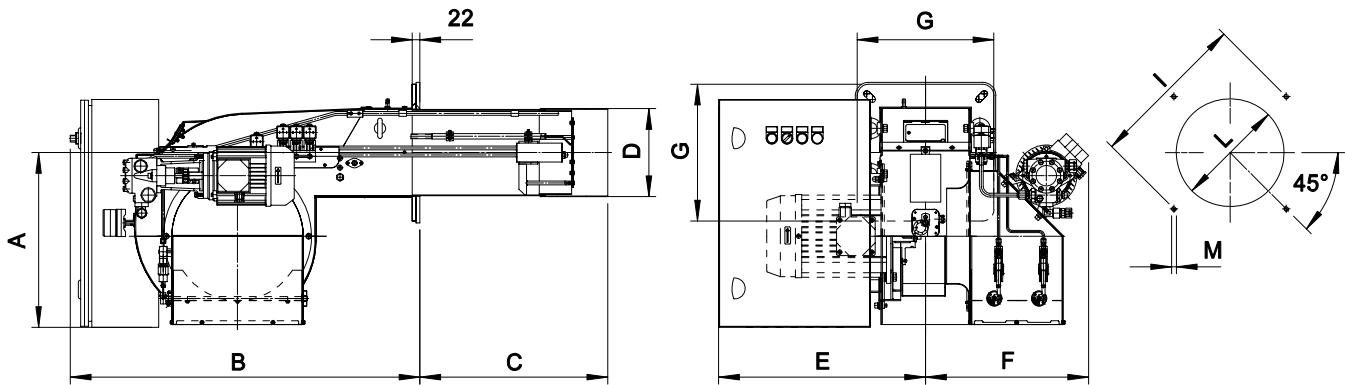

MODEL MODELLO	A	B	C	D	E	F	G	I min	I *	I max	L min	L *	L max	M
FGP 190/3	453	920	495	234	545	429	360	396	424	438	245	280	320	M14
FGP 250/3	453	920	500	271	545	460	360	396	424	438	280	280	320	M14
FGP 350/3	481	1090	535	334	600	517	490	552	552	580	350	350	450	M14
FGP 450/3	481	1090	560	380	600	517	490	552	552	580	390	390	450	M14

* Suggested/Consigliato



PROGRESSIVE & MODULATING PROGRESSIVI E MODULANTI	kg/h		kW		⚡
	min	max	min	max	
FGP 190/M *	20/60	206	232/712	2443	3F
FGP 250/M *	26/80	250	302/949	2965	
FGP 350/M *	46/140	350	534/1660	4151	
FGP 450/M *	53/160	450	615/1898	5337	
FGP 550/M *	66/200	550	766/2372	6523	

* Available also versions with INVERTER and ELECTRONIC BURNER CONTROL
 * Fornibili anche in versioni speciali con INVERTER e CAMMA ELETTRONICA

FIRING RATES / OVERALL DIMENSIONS (mm) - CAMPO DI LAVORO / DIMENSIONI (mm)

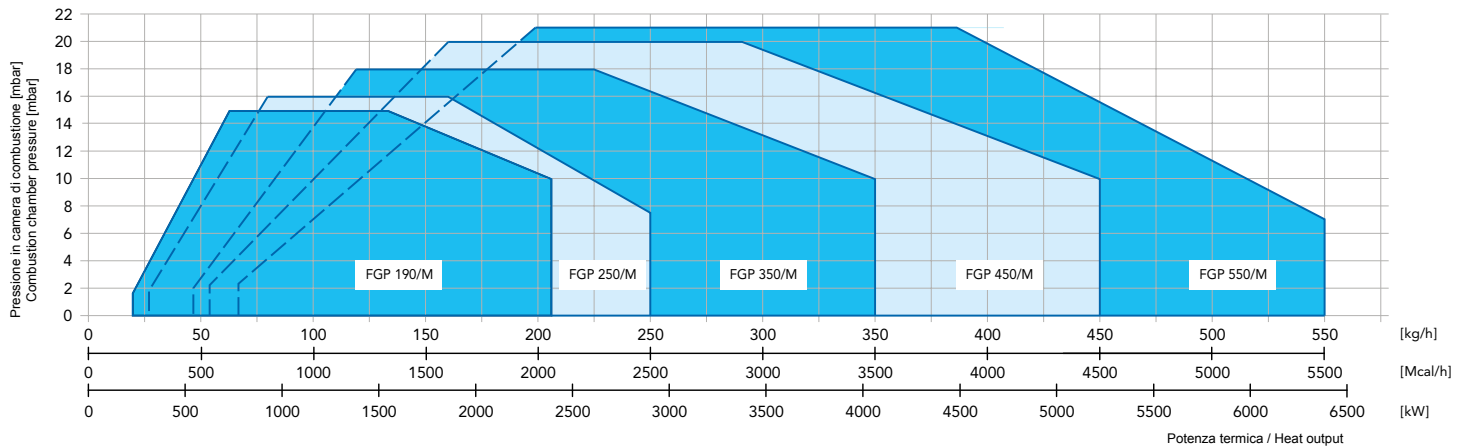
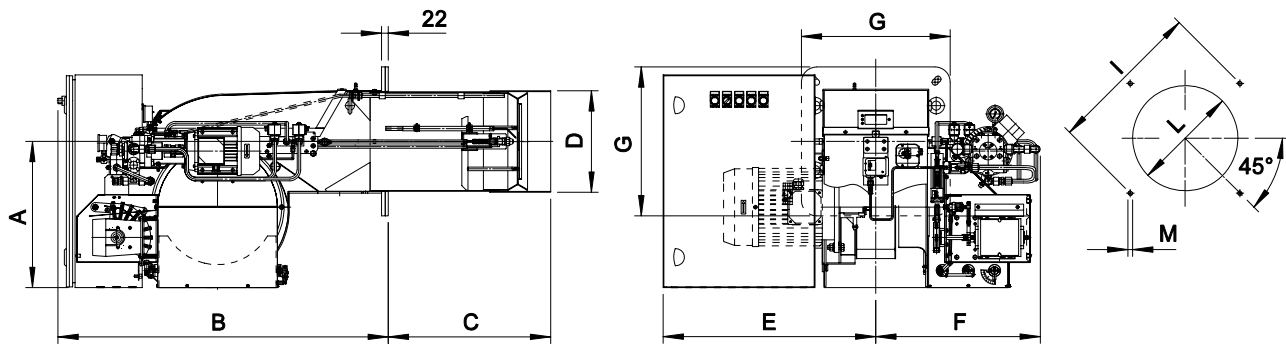

MODEL MODELLO	A	B	C	D	E	F	G	I min	I *	I max	L min	L *	L max	M	* Suggested/Consigliato
FGP 190/M	453	920	495	234	545	530	360	396	424	438	245	280	320	M14	
FGP 250/M	453	920	500	271	545	530	360	396	424	438	280	280	320	M14	
FGP 350/M	481	1090	535	334	600	540	490	552	552	580	350	350	450	M14	
FGP 450/M	481	1090	560	380	600	540	490	552	552	580	390	390	450	M14	
FGP 550/M	481	1090	560	380	600	540	490	552	552	580	390	410	450	M14	



PROGRESSIVE & MODULATING PROGRESSIVI E MODULANTI	kg/h		kW		⚡
	min	max	min	max	
FGP 650/M *	85/294	637	986/3488	7558	3F
FGP 750/M *	97/333	735	1125/3953	8721	
FGP 1000/M *	97/333	980	1125/3953	11628	
FGP 1300/M *	100/353	1127	1160/4186	13372	
FGP 1500/M *	100/353	1274	1160/4186	15116	
FGP 1800/M *	142/490	1471	1647/5814	17442	

* Available also versions with INVERTER and ELECTRONIC BURNER CONTROL
 * Fornibili anche in versioni speciali con INVERTER e CAMMA ELETTRONICA

FIRING RATES / OVERALL DIMENSIONS (mm) - CAMPO DI LAVORO / DIMENSIONI (mm)

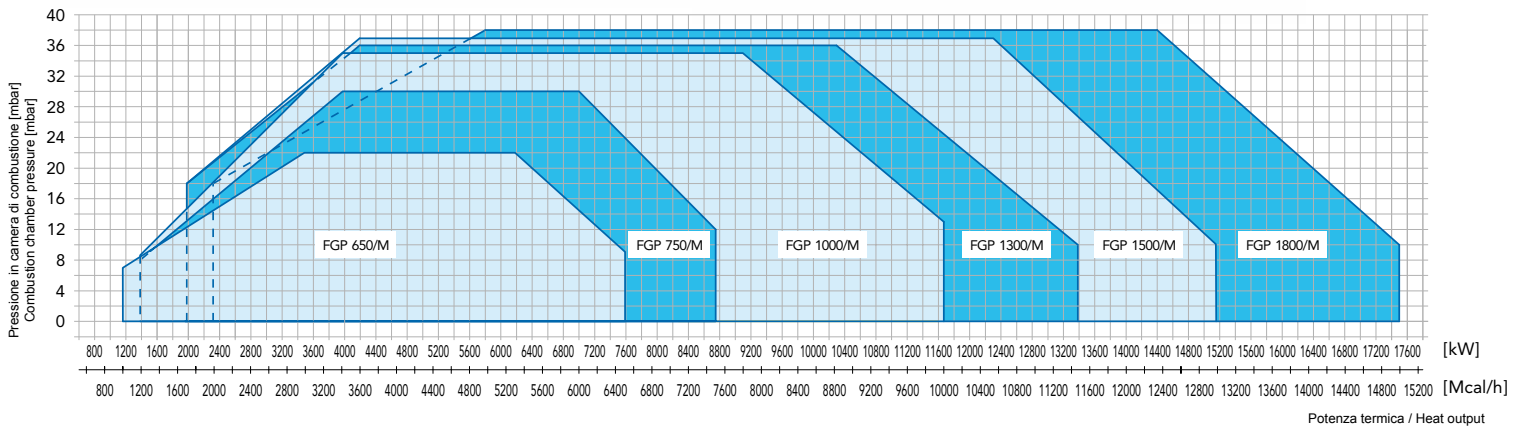

Please contact our Technical & Sales Offices for detailed technical data.

Vi invitiamo a contattare i ns. Uffici Tecnico-Commerciali per i dati tecnici di dettaglio.

HEAVY OIL BURNERS

BRUCIATORI DI OLIO COMBUSTIBILE





1 STAGE MONOSTADIO	kg/h		kW		
	min	max	min	max	
FNDL 8	5	8	57	91,1	1F
FNDL 16	7	16	79,8	182	
FNDL 25	12,5	25	142	285	3F

FIRING RATES / OVERALL DIMENSIONS (mm) - CAMPO DI LAVORO / DIMENSIONI (mm)

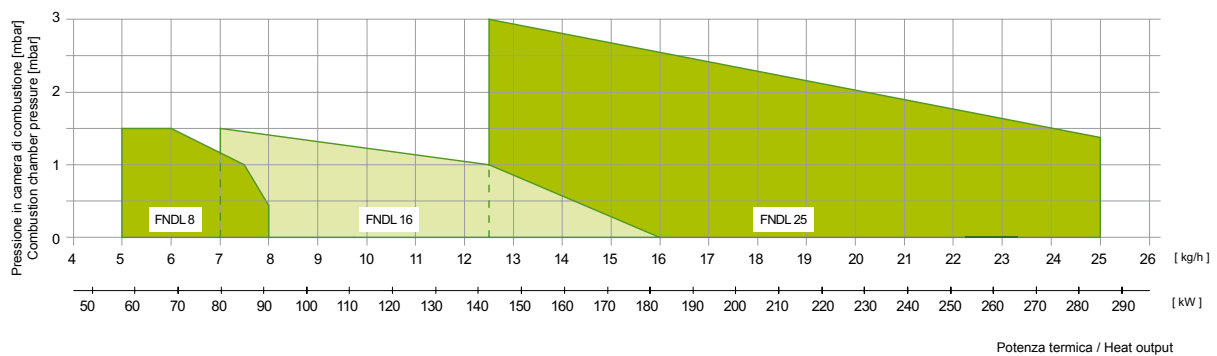
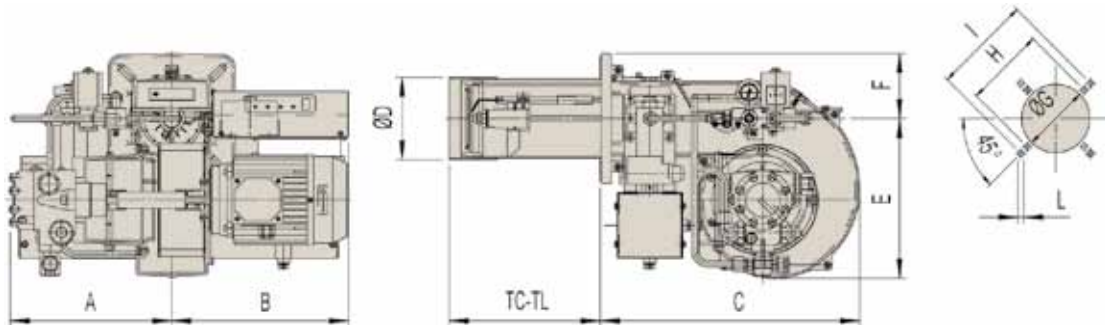

MODEL MODELLO	A	B	C	D	E	F	G	H	I	L	TC	TL
FNDL 8	253	294	410	107	251	102	120	180	226	M10	110	230
FNDL 16	253	294	410	107	251	102	120	180	226	M10	110	230
FNDL 25	255	294	410	130	251	102	140	180	226	M10	120	240

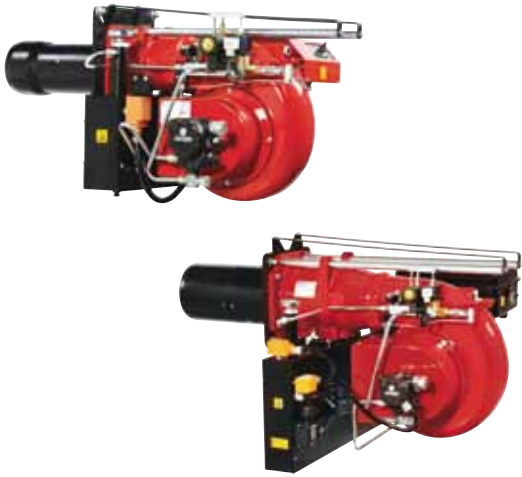

2 STAGES BISTADIO	kg/h		kW		3F
	min	max	min	max	
FNDP 25/2	12	25	137	285	3F
FNDP 45/2	20	45	228	513	
FNDP 70/2	35	70	399	798	
FNDP 100/2	40	100	456	1139	
FNDP 125/2	60	125	684	1424	
FNDP 150/2	70	150	798	1744	

FIRING RATES / OVERALL DIMENSIONS (mm) - CAMPO DI LAVORO / DIMENSIONI (mm)

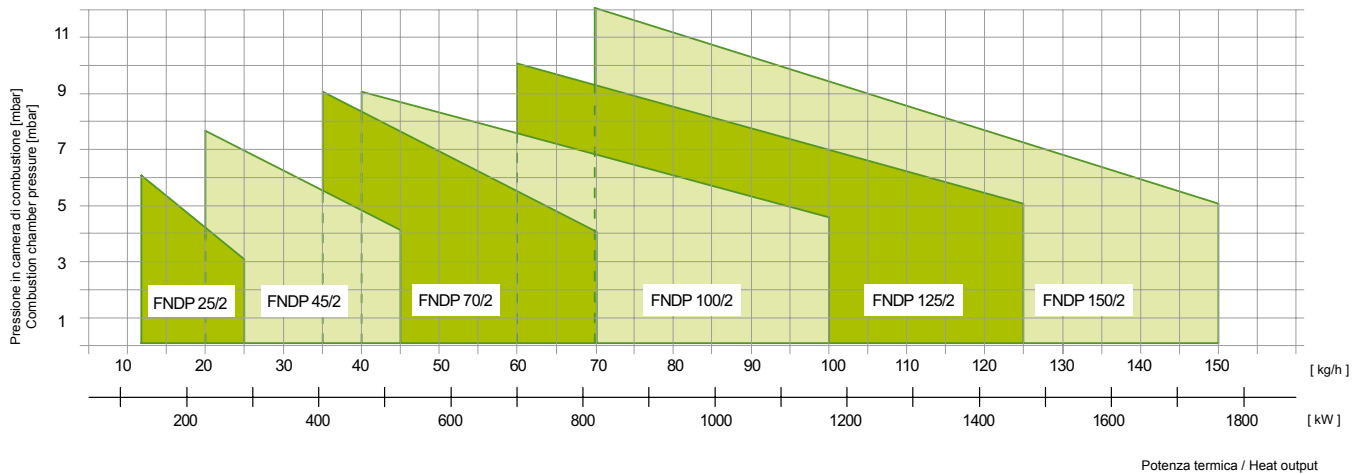
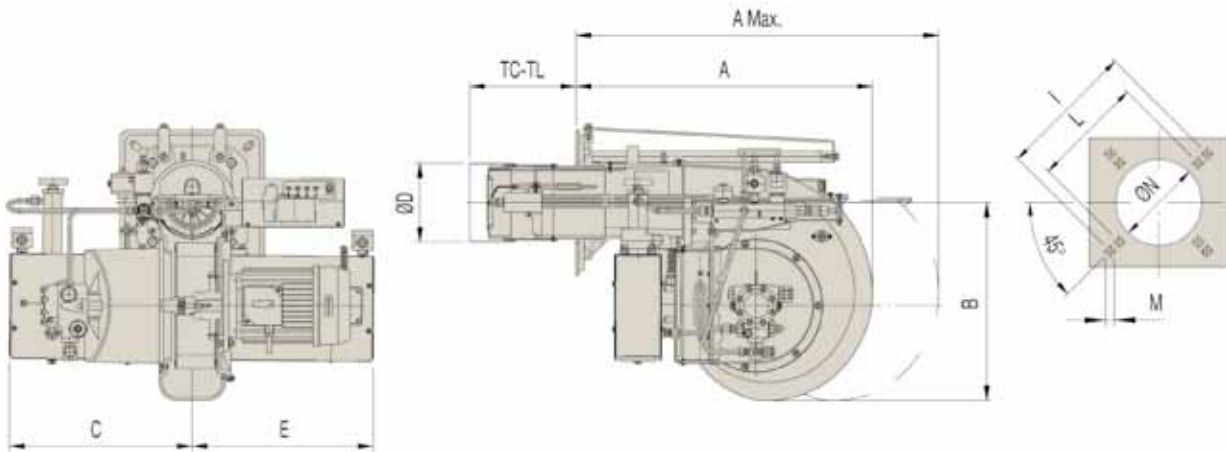

MODEL MODELLO	A	A Max.	B	C	D	E	TC	TL	I	L	M	N
FNDP 25/2	540	950	325	295	135	319	170	350	340	283	M12	145
FNDP 45/2	540	950	325	295	155	319	170	350	340	283	M12	160
FNDP 70/2	660	1100	355	295	165	326	250	350	368	340	M12	180
FNDP 100/2	656	1085	440	410	175	400	235	335	368	340	M12	190
FNDP 125/2	820	1400	520	420	209	400	200	400	368	340	M14	230
FNDP 150/2	820	1400	520	420	209	400	200	400	368	340	M14	230



PROGRESSIVE & MODULATING PROGRESSIVI E MODULANTI	kg/h		kW		⚡
	min	max	min	max	
FNDP 70/M	18/35	70	205/399	798	3F
FNDP 100/M	20,5/40	100	233/456	1139	
FNDP 125/M	29/60	125	330/684	1424	
FNDP 150/M	38,5/75	150	438/854	1744	

FIRING RATES / OVERALL DIMENSIONS (mm) - CAMPO DI LAVORO / DIMENSIONI (mm)

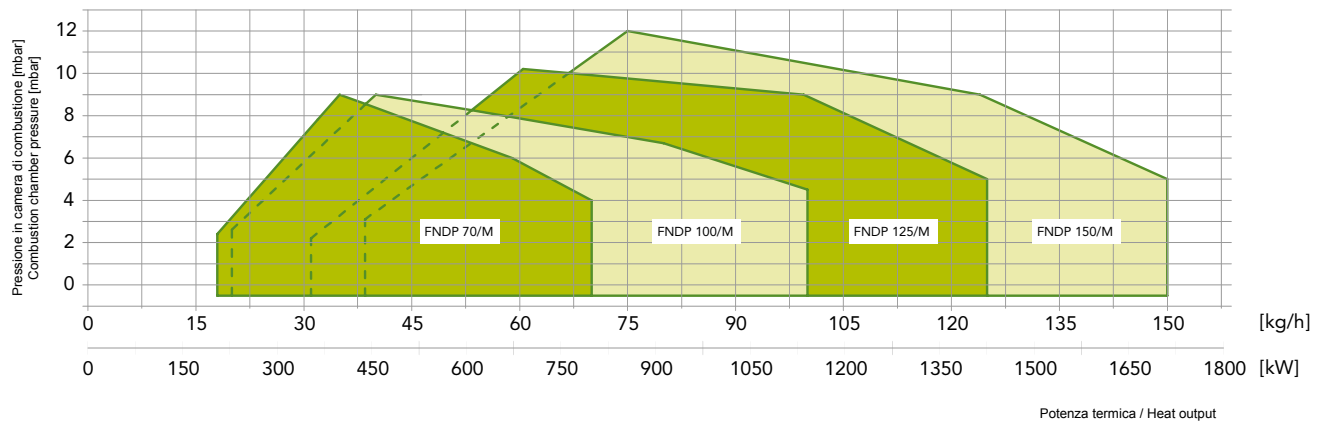
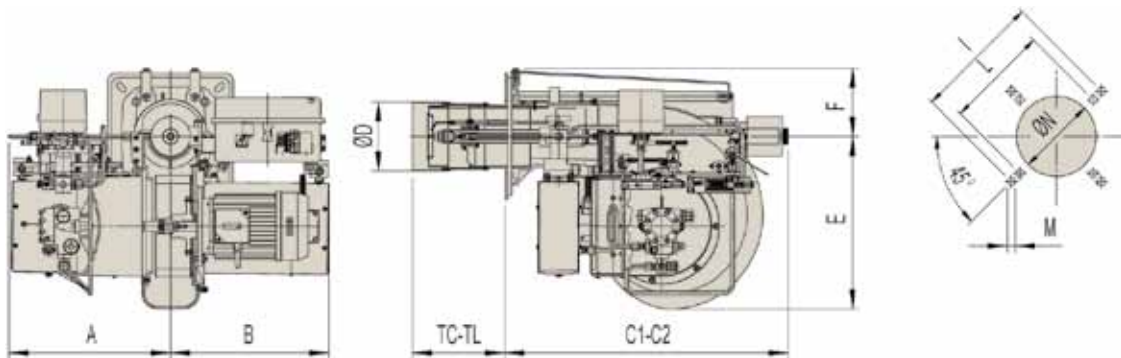

MODEL MODELLO	A	B	C1	C2	D	E	F	TC	TL	I	L	M	N
FNDP 70/M	360	385	735	1175	165	355	171	250	350	368	340	M12	180
FNDP 100/M	410	400	720	1150	175	440	173	235	335	368	340	M12	190
FNDP 125/M	420	400	860	1440	209	520	213	200	400	368	340	M14	230
FNDP 150/M	420	400	860	1440	209	520	213	200	400	368	340	M14	230

C2= overall dimension with the burner out in position of maintenance
C2= ingombro a bruciatore arretrato in posizione di manutenzione



3 STAGES TRISTADIO	kg/h		kW		
	min	max	min	max	
FNDP 190/3	40/80	206	456/911	2347	3F
FNDP 250/3	50/100	250	570/1139	2849	
FNDP 350/3	60/120	350	684/1367	3988	

FIRING RATES / OVERALL DIMENSIONS (mm) - CAMPO DI LAVORO / DIMENSIONI (mm)

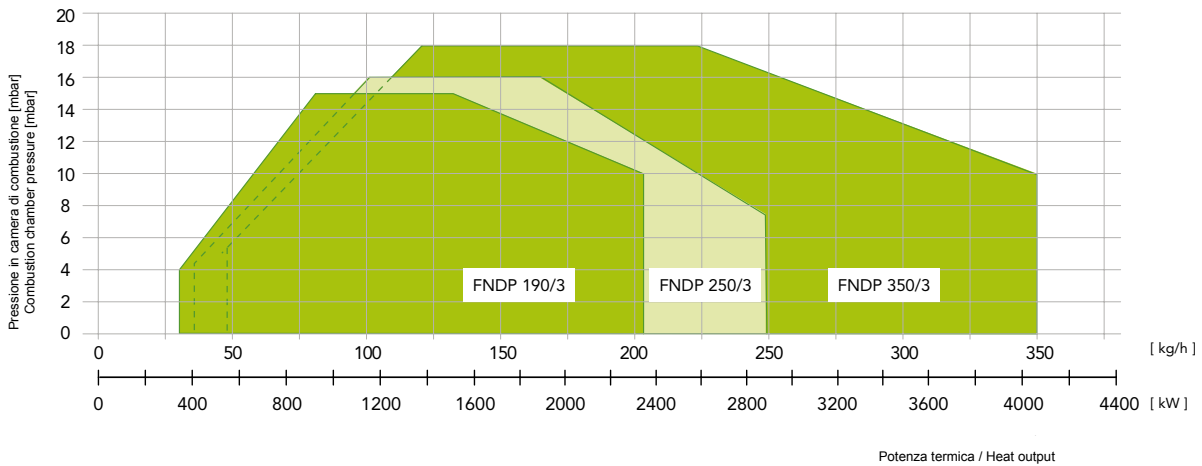
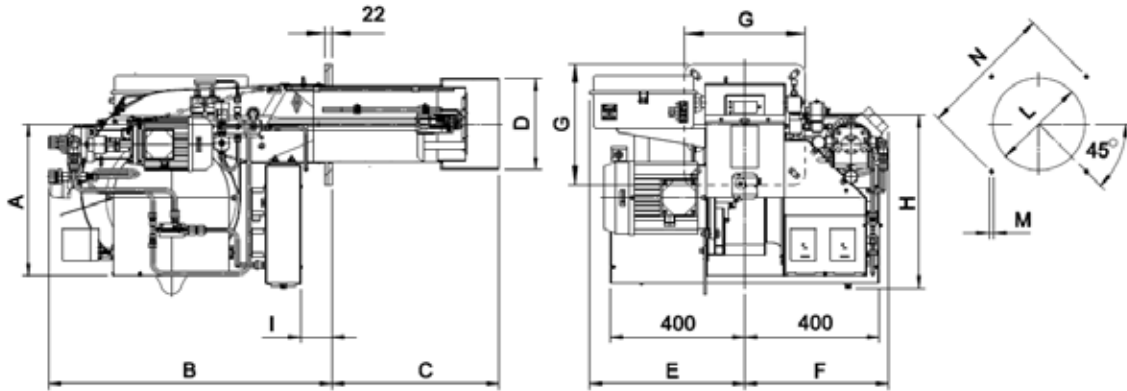

MODEL MODELLO	* Suggested/Consigliato																
	A	B	C	D	E	F	G	H	I	L min	L*	L max	M	N min	N*	N max	R
FNDP 190/3	453	850	495	234	464	430	360	490	93	245	280	320	M14	396	424	438	R30
FNDP 250/3	453	850	500	271	464	430	360	490	93	280	280	320	M14	396	424	438	R30
FNDP 350/3	481	942	535	334	575	488	490	494	75	350	350	450	M14	552	552	580	R50



PROGRESSIVE & MODULATING PROGRESSIVI E MODULANTI	kg/h		kW		3F
	min	max	min	max	
FNDP 190/M *	40/80	206	456/911	2347	
FNDP 250/M *	50/100	250	570/1139	2849	
FNDP 350/M *	60/120	350	684/1367	3988	

* Available also versions with INVERTER and ELECTRONIC BURNER CONTROL
* Fornibili anche in versioni speciali con INVERTER e CAMMA ELETTRONICA

FIRING RATES / OVERALL DIMENSIONS (mm) - CAMPO DI LAVORO / DIMENSIONI (mm)

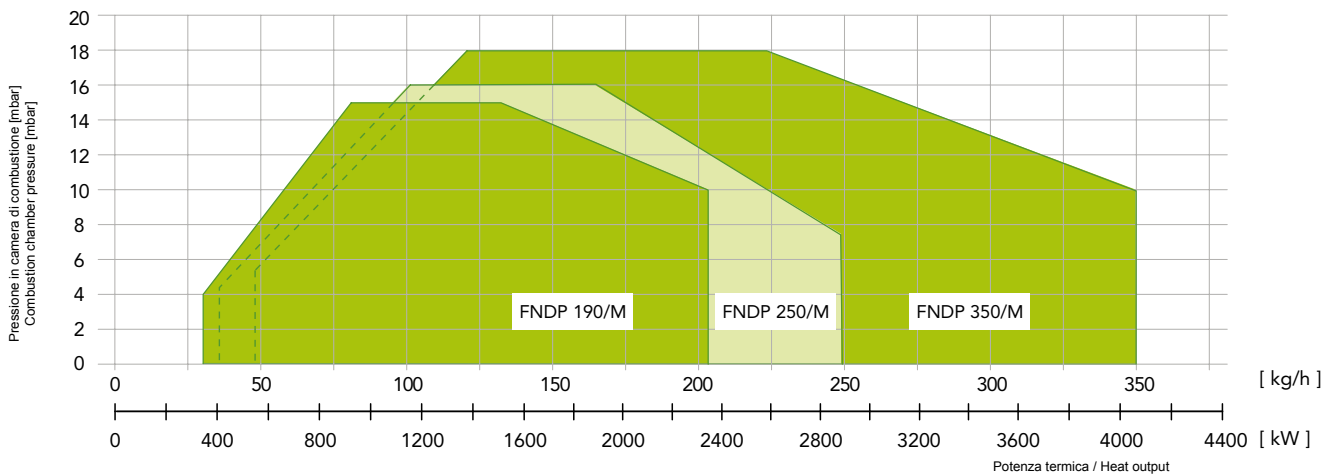
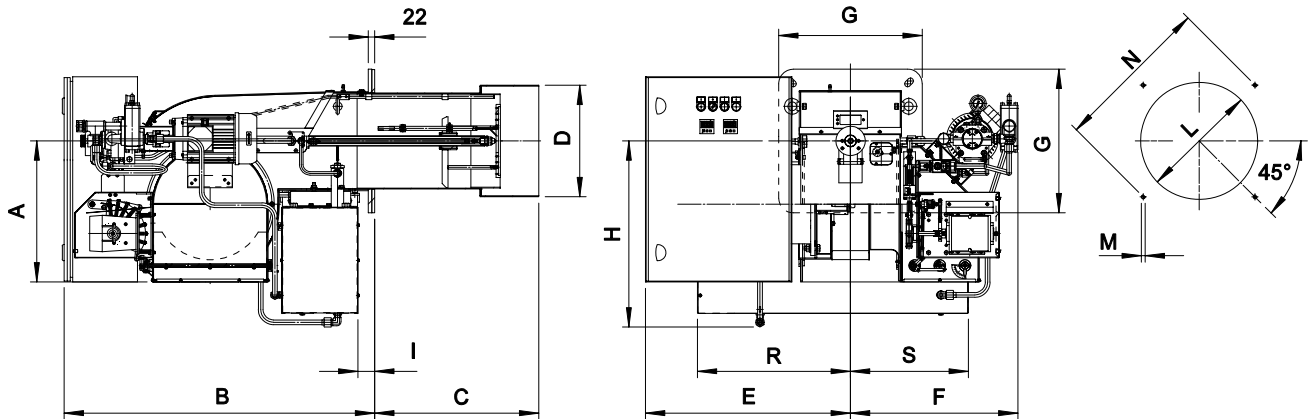

MODEL MODELLO	A	B	C	D	E	F	G	H	I	L min	L*	L max	M	N min	N*	N max	R	S
	FNDP 190/M	453	920	495	234	545	536	360	490	93	245	280	320	M14	396	424	438	400
FNDP 250/M	453	920	500	271	545	536	360	490	93	280	280	320	M14	396	424	438	400	400
FNDP 350/M	481	1025	535	334	600	565	490	495	75	350	350	450	M14	552	552	580	400	400

* Suggested/Consigliato



PROGRESSIVE & MODULATING PROGRESSIVI E MODULANTI	kg/h		kW		
	min	max	min	max	
FNDP 450/M *	80/160	450	911/1823	5128	3F
FNDP 550/M *	100/200	550	1139/2279	6267	

* Available also versions with INVERTER and ELECTRONIC BURNER CONTROL
* Fornibili anche in versioni speciali con INVERTER e CAMMA ELETTRONICA

FIRING RATES / OVERALL DIMENSIONS (mm) - CAMPO DI LAVORO / DIMENSIONI (mm)

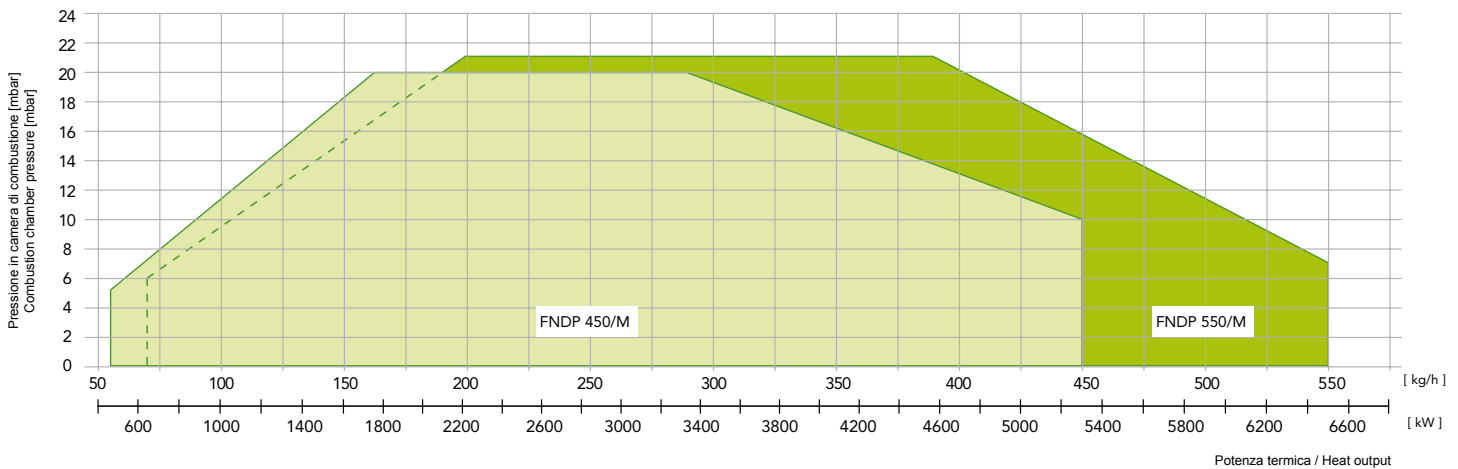
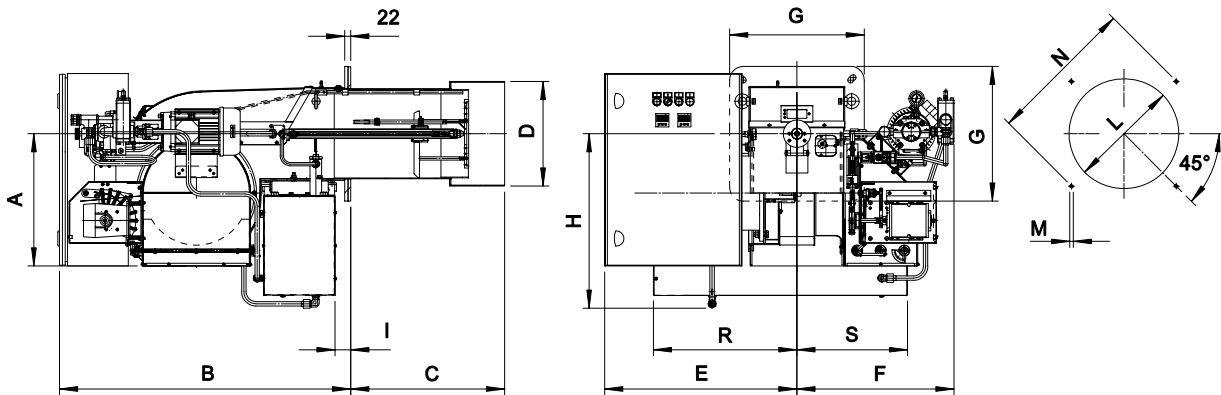

MODEL MODELLO	* Suggested/Consigliato																	
	A	B	C	D	E	F	G	H	I	L min	L*	L max	M	N min	N*	N max	R	S
FNDP 450/M	481	1100	560	380	700	571	490	635	57	390	390	450	M14	552	552	580	520	400
FNDP 550/M	481	1100	560	380	700	571	490	635	57	390	410	450	M14	552	552	580	520	400



PROGRESSIVE & MODULATING PROGRESSIVI E MODULANTI	kg/h		kW		3F
	min	max	min	max	
FNDP 650/M *	100/306	663	1139/3488	7558	3F
FNDP 750/M *	114/347	765	1299/3953	8721	
FNDP 1000/M *	114/347	1020	1299/3953	11628	
FNDP 1300/M *	123/367	1173	1401/4186	13372	
FNDP 1500/M *	123/367	1326	1401/4186	15116	
FNDP 1800/M *	167/510	1531	1903/5814	17442	

* Available also versions with INVERTER and ELECTRONIC BURNER CONTROL
 * Fornibili anche in versioni speciali con INVERTER e CAMMA ELETTRONICA

FIRING RATES / OVERALL DIMENSIONS (mm) - CAMPO DI LAVORO / DIMENSIONI (mm)

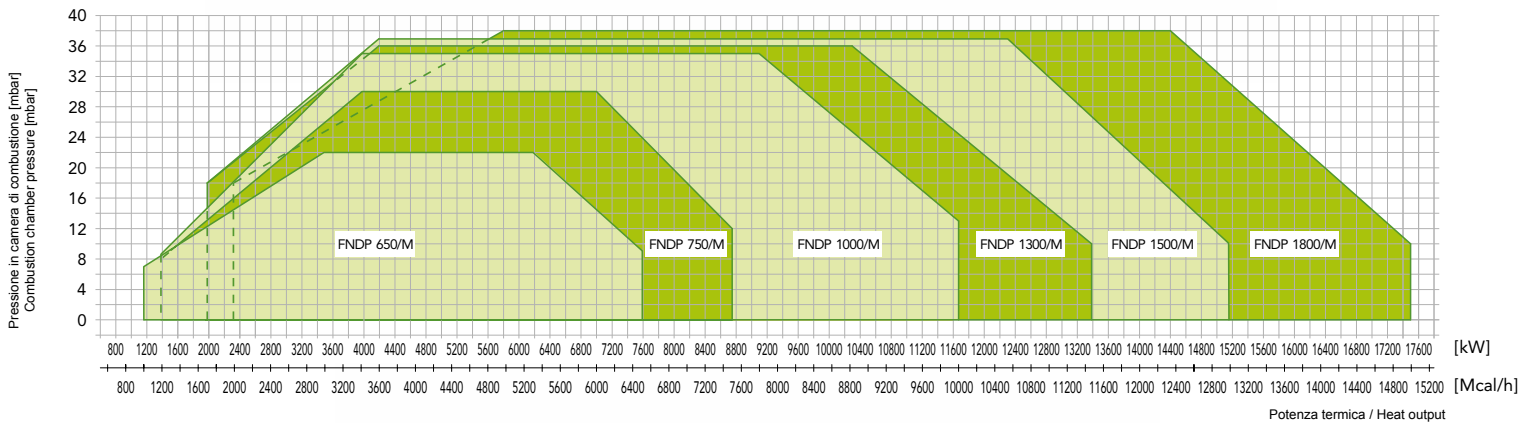

Please contact our Technical & Sales Offices for detailed technical data.

Vi invitiamo a contattare i ns. Uffici Tecnico-Commerciali per i dati tecnici di dettaglio.

GAS BURNERS
BRUCIATORI DI GAS



3





1 STAGE MONOSTADIO	kcal/h		kW		1F
	min	max	min	max	
GAS X 0	10.000	29.500	11,6	34,3	
GAS X 1	20.000	50.000	23,2	58,1	
GAS X 2	35.000	80.000	40,7	93	
GAS X 3 *	60.000	150.000	69,8	174	
GAS X 4 *	100.000	200.000	116	232	
GAS X 5	130.000	300.000	151	349	

* Available also in Low NOx version
* Disponibili anche in versione Low NOx

FIRING RATES / OVERALL DIMENSIONS (mm) - CAMPO DI LAVORO / DIMENSIONI (mm)

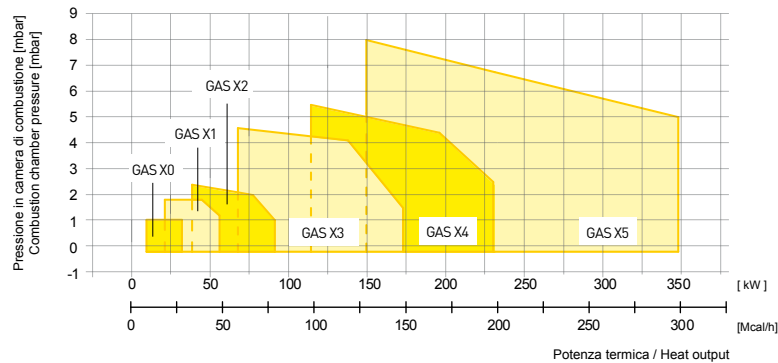
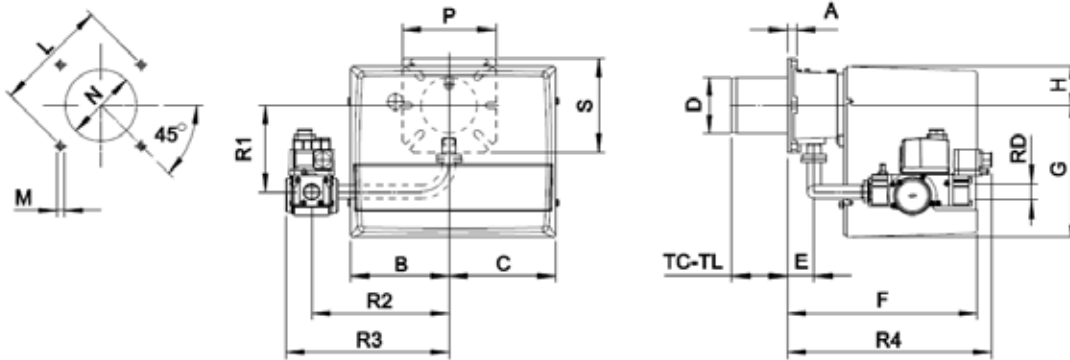

MODEL MODELLO	* Suggested/Consigliato																							
	A	B	C	D	E	F	G	H	L min	L*	L max	M	N min	N*	N max	P	S	TC	TL	R1	R2	R3	R4	RD
GAS X0 CE - D1/2"-S	15	140	140	90	43	265	169	72	130	150	170	M8	100	110	130	150	150	90	150	132	200	254	240	1/2"
GAS X1 CE - D1/2"-S	15	162	175	90	43	305	210	65	130	150	170	M8	100	110	130	150	150	90	150	132	200	254	240	1/2"
GAS X2 CE - D3/4"-S	15	162	175	90	43	305	210	65	130	150	170	M8	100	110	130	150	150	90	150	138	220	262	328	3/4"
GAS X3 CE - D1"-S	16	185	195	108	54	340	248	70	150	170	170	M8	120	130	140	200	160	130	250	168	280	337	361	1"
GAS X4 CE - D1"-S	20	185	195	125	78	368	248	70	170	205	226	M10	130	140	160	200	200	160	280	173	280	337	385	1"
GAS X5 CE - D1"-S	18	207	213	138	98	462	310	90	205	205	226	M10	150	150	180	200	200	250	335	160	305	362	403	1"
GAS X5 CE - CT-D1"-S	18	207	213	138	98	462	310	90	205	205	226	M10	150	150	180	200	200	250	335	160	305	480	403	1"
GAS X5 CE - D1 1/4"-S	18	207	213	138	98	462	310	90	205	205	226	M10	150	150	180	200	200	250	335	160	305	362	450	1 1/4"
GAS X5 CE - CT-D1 1/4"-S	18	207	213	138	98	462	310	90	205	205	226	M10	150	150	180	200	200	250	335	160	305	480	450	1 1/4"



2 STAGES BISTADIO	PROGRESSIVE & MODULANTING Progressivi e modulanti	kcal/h		kW	
		min	max	min	max
GAS X 1/2		20.000	50.000	18/23,2	58,1
GAS X 2/2	GAS X 2/M	35.000	80.000	24,4/40,7	93
GAS X 3/2 *	GAS X 3/M *	60.000	150.000	34,9/69,8	174
GAS X 4/2 *	GAS X 4/M *	100.000	200.000	64/116	232
GAS X 5/2 *	GAS X 5/M *	130.000	300.000	81,4/151	349

* Available also in Low NOx version
* Disponibili anche in versione Low NOx

FIRING RATES / OVERALL DIMENSIONS (mm) - CAMPO DI LAVORO / DIMENSIONI (mm)

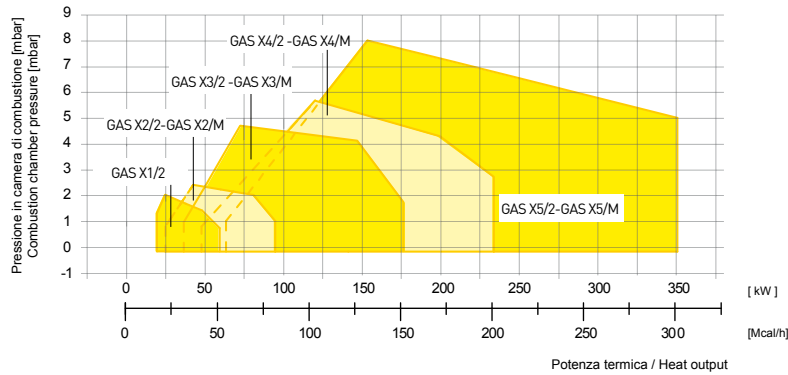
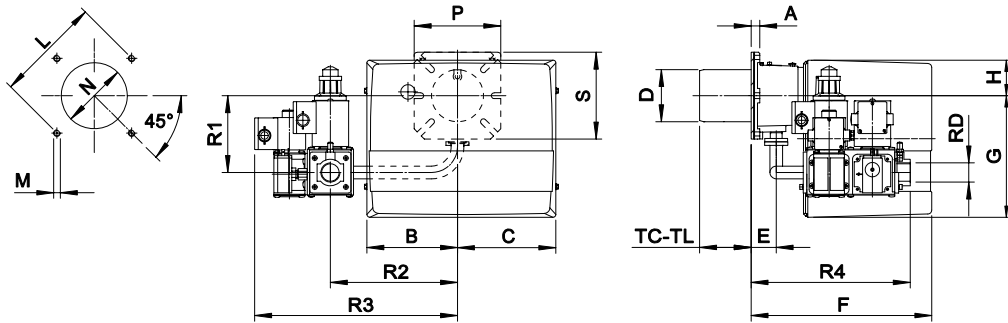

MODEL MODELLO	* Suggested/Consigliato																							
	A	B	C	D	E	F	G	H	L min	L* max	L max	M	N min	N* max	N max	P	S	TC	TL	R1	R2	R3	R4	RD
GAS X 1/2 CE - D1" S	15	162	175	90	45	313	210	65	130	150	170	M8	100	110	130	150	150	90	150	132	200	275	258	1/2"
GAS X 2/2 CE - D3/4" FS25	15	162	175	90	45	313	210	65	130	150	170	M8	100	110	130	150	150	90	150	138	220	351	275	1"
GAS X 3/2 CE - D1" S	16	185	195	108	52	340	248	70	150	170	170	M8	120	130	140	200	160	130	250	168	280	337	361	1"
GAS X 4/2 CE - D1" S	20	185	195	125	78	368	248	70	170	205	226	M10	130	140	160	200	200	160	280	173	280	337	385	1"
GAS X 5/2 CE - D1" S	18	207	213	138	98	462	310	90	205	205	226	M10	150	150	180	200	200	250	335	255	305	362	403	1"
GAS X 5/2 CE - CT D1" S	18	207	213	138	98	462	310	90	205	205	226	M10	150	150	180	200	200	250	335	255	305	480	403	1"
GAS X 5/2 CE - D1" 1/4 S	18	207	213	138	98	462	310	90	205	205	226	M10	150	150	180	200	200	250	335	255	305	362	450	1" 1/4
GAS X 5/2 CE - CT D1" 1/4 S	18	207	213	138	98	462	310	90	205	205	226	M10	150	150	180	200	200	250	335	255	305	480	450	1" 1/4
GAS X 2/M CE - D3/4" S	15	162	200	90	45	305	211	65	130	150	170	M8	100	110	130	150	150	90	150	178	220	262	346	3/4"
GAS X 3/M CE - D1" S	16	185	224	108	54	340	248	70	150	170	170	M8	120	130	140	200	160	130	250	228	280	338	360	1"
GAS X 4/M CE - D1" S	20	185	224	125	78	368	248	70	170	205	226	M10	130	140	160	200	200	160	280	233	280	338	385	1"
GAS X 5/M CE - D1" S	18	207	213	138	98	462	310	165	205	205	226	M10	150	150	180	200	200	250	335	160	305	395	508	1"
GAS X 5/M CE - D1" 1/4 S	18	207	213	138	98	462	310	165	205	205	226	M10	150	150	180	200	200	250	335	160	305	395	508	1" 1/4



1 STAGE for bakery ovens MONOSTADIO per forni da pane	kcal/h		kW		1F
	min	max	min	max	
GAS X1F	20.000	50.000	23,2	58,1	
GAS X2F	35.000	80.000	40,7	93	
GAS X3F	60.000	150.000	69,8	174	
GAS X4F	100.000	200.000	116	232	
GAS X5F	130.000	300.000	151	349	

FIRING RATES / OVERALL DIMENSIONS (mm) - CAMPO DI LAVORO / DIMENSIONI (mm)

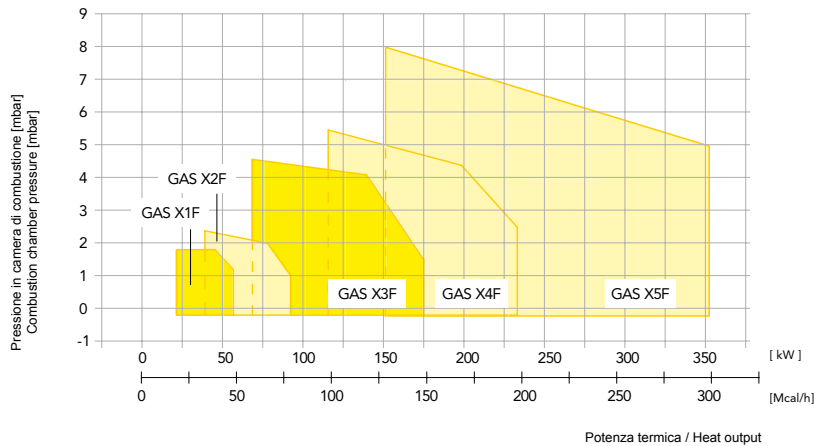
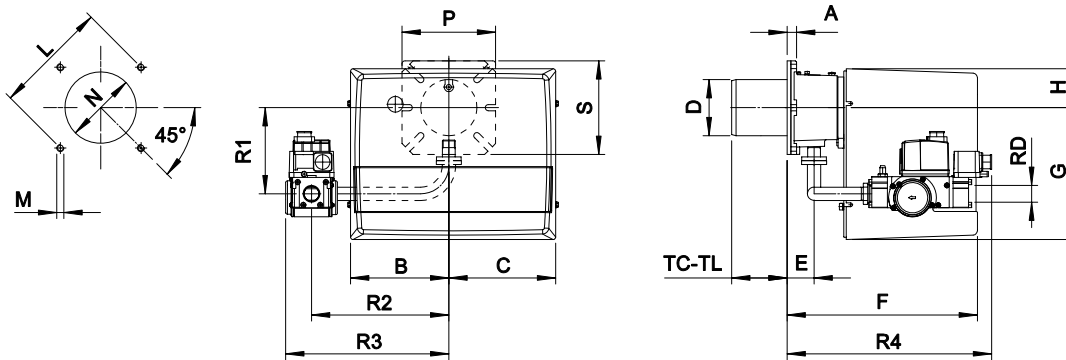

MODEL MODELLO	* Suggested/Consigliato																							
	A	B	C	D	E	F	G	H	L min	L*	L max	M	N min	N*	N max	P	S	TC	TL	R1	R2	R3	R4	RD
GAS X1 CE F - D1/2" S	15	162	175	90	43	305	210	65	130	150	170	M8	100	110	130	150	150	90	150	132	200	254	240	1/2"
GAS X2 CE F - D3/4" S	15	162	175	90	43	305	210	65	130	150	170	M8	100	110	130	150	150	90	150	138	220	262	328	3/4"
GAS X3 CE F - D1" S	16	185	195	108	54	340	248	70	150	170	170	M8	120	130	140	200	160	130	250	168	280	337	361	1"
GAS X4 CE F - D1" S	20	185	195	125	78	368	248	70	170	205	226	M10	130	140	160	200	200	160	280	173	280	337	385	1"
GAS X5 CE F - D1" S	18	207	213	138	98	462	310	90	205	205	226	M10	150	150	180	200	200	250	335	160	305	362	403	1"



1 STAGE For kitchens MONOSTADIO per cucine	kcal/h		kW		
	min	max	min	max	
GAS 1/C	10.000	40.000	11,6	46,5	1F
GAS 2/C	15.000	60.000	17,5	69,8	

SERIE "X0 THLS" for units per units	kcal/h		kW		
	min	max	min	max	
GAS X0 THLS	10.000	29.500	11,6	34,3	1F

FIRING RATES / OVERALL DIMENSIONS (mm) - CAMPO DI LAVORO / DIMENSIONI (mm)

GAS 1/C - GAS 2/C

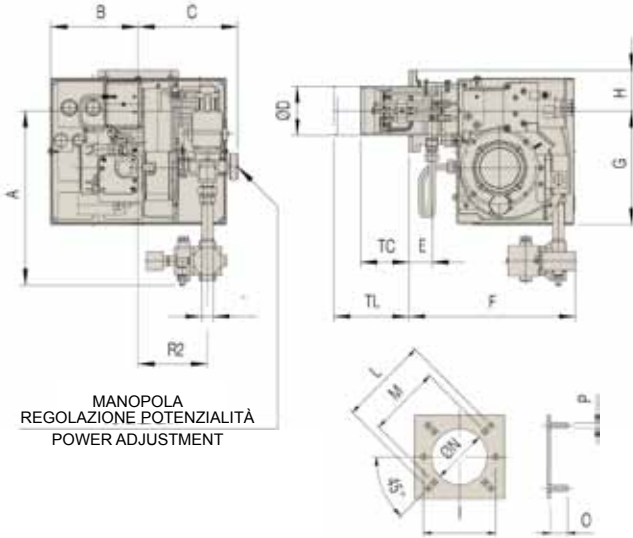

GAS X0 THLS

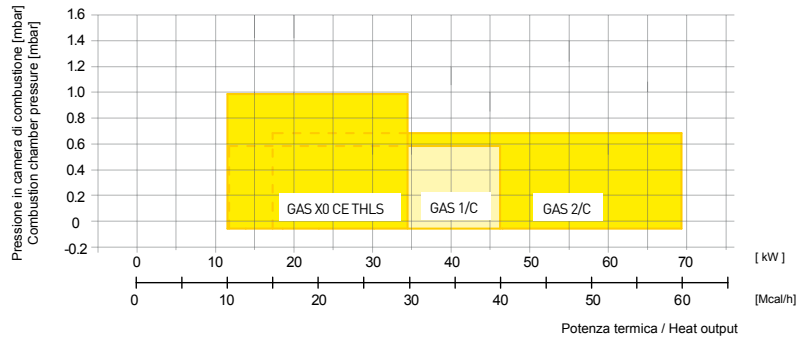
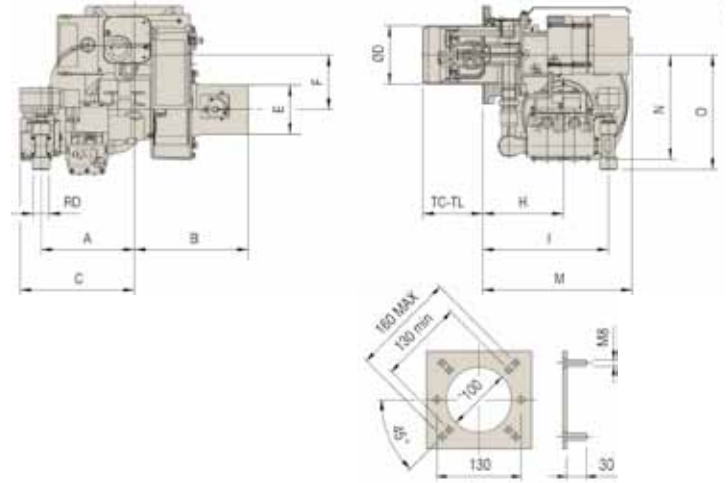

MODEL MODELLO	A	B	C	D	E	F	G	H	I	L	M	N	O	P	TC	TL	R2	
GAS 1/C	321	166	184	90	43	310	210	75	130	160	130	100	30	M8	85	145	128	1/2"
GAS 2/C	321	166	184	90	43	310	210	75	130	160	130	100	30	M8	85	145	128	1/2"

MODEL MODELLO	A	B	C	D	E	F	H	I	TC	TL	M	N	O	RD
GAS X0 CE THLS - D1/2"	144	169	176	90	80	84	125	193	92	152	230	161	176	1/2"



1 STAGE MONOSTADIO	kcal/h		kW		3F
	min	max	min	max	
GAS XP 60	200.000	450.000	232	523	

FIRING RATES / OVERALL DIMENSIONS (mm) - CAMPO DI LAVORO / DIMENSIONI (mm)

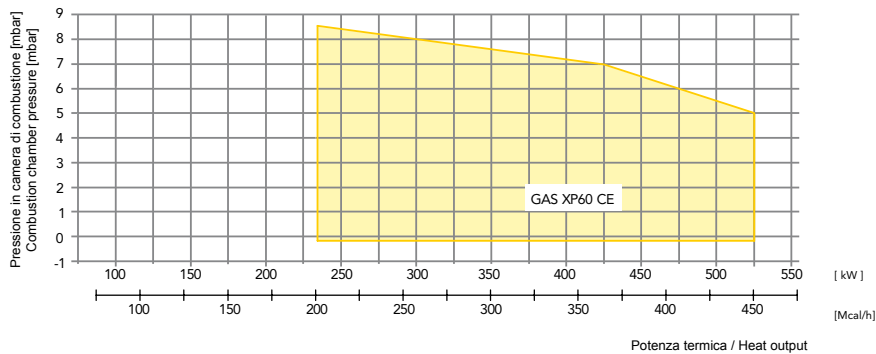
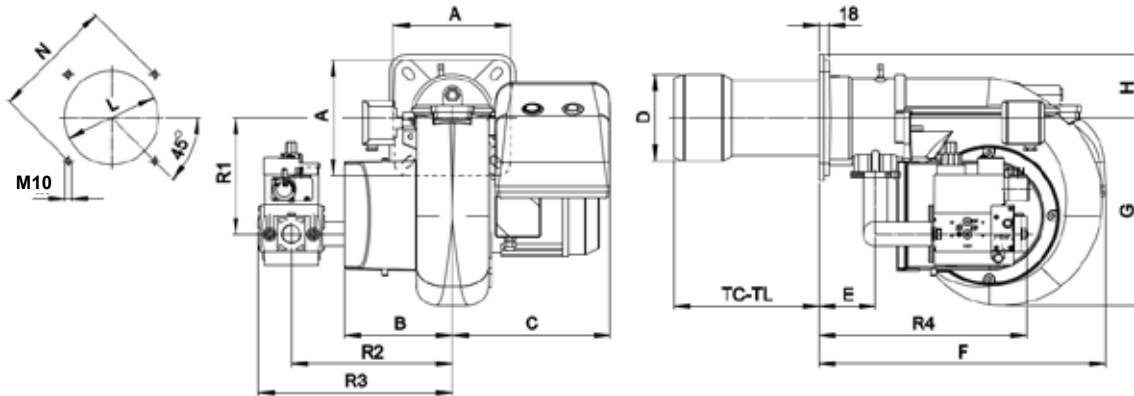

* Suggested/Consigliato

MODEL MODELLO	A	B	C	D	E	F	G	H	L min*	L max	N min*	N max	TC	TL	R1	R2	R3	R4	RD
GASP XP 60 CE - D1" - S	200	188	278	150	98	500	327	70	205	226	160	180	250	335	203	280	338	428	1"
GASP XP 60 CE - D1" 1/4- S	200	188	278	150	98	500	327	70	205	226	160	180	250	335	203	280	338	428	1" 1/4
GAS XP 60 CE - D1" 1/2 - S	200	188	278	150	98	500	327	70	205	226	160	180	250	335	203	280	330	444	1" 1/2



2 STAGES BISTADIO	PROGRESSIVE & MODULATING PROGRESSIVI E MODULANTI	kcal/h		kW		
		min	max	min	max	
-	GAS XP 40/M *	130.000	300.000	64/151	348	1F
GAS XP 60/2 *	GAS XP 60/M *	200.000	450.000	116/232	523	3F

* Available also in Low NOx version
* Disponibili anche in versione Low NOx

FIRING RATES / OVERALL DIMENSIONS (mm) - CAMPO DI LAVORO / DIMENSIONI (mm)

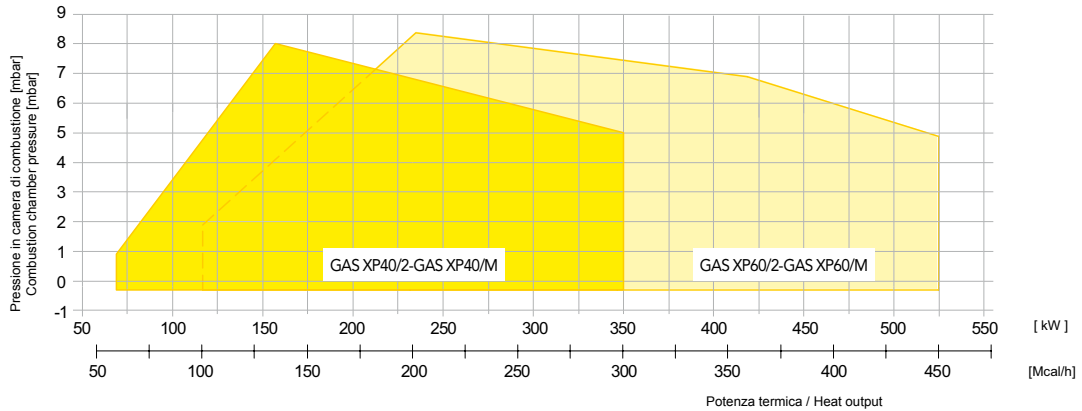
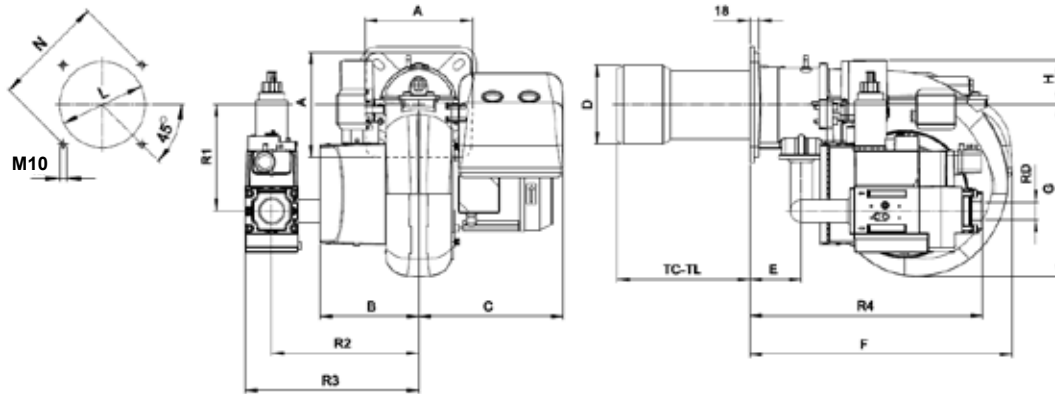

* Suggested/Consigliato

MODEL MODELLO	A	B	C	D	E	F	G	H	L min*	L max	N min*	N max	TC	TL	R1	R2	R3	R4	RD
GAS XP 40/M - D1" - S	200	298	275	138	98	500	327	110	160	180	205	226	250	335	202	414	468	459	1"
GAS XP 40/M - D1" 1/4 - S	200	298	275	138	98	500	327	110	160	180	205	226	250	335	202	414	468	459	1" 1/4
GAS XP 40/M - D1" 1/2 - S	200	298	275	138	98	500	327	110	160	180	205	226	250	335	202	414	468	459	1" 1/2
GAS XP 60/2 CE - D1" - S	200	188	276	150	98	500	327	85	160	180	205	226	250	335	203	280	338	428	1"
GAS XP 60/2 CE - D1" 1/4 - S	200	188	276	150	98	500	327	85	160	180	205	226	250	335	203	280	338	428	1" 1/4
GAS XP 60/2 CE - D1" 1/2 - S	200	188	276	150	98	500	327	85	160	180	205	226	250	335	203	280	330	444	1" 1/2
GAS XP 60/M CE - D1" - S	200	298	275	150	98	500	327	110	160	180	205	226	250	335	202	414	468	459	1"
GAS XP 60/M CE - D1" 1/4 - S	200	298	275	150	98	500	327	110	160	180	205	226	250	335	202	414	468	459	1" 1/4
GAS XP 60/M CE - D1" 1/2 - S	200	298	275	150	98	500	327	110	160	180	205	226	250	335	202	414	468	459	1" 1/2



2 STAGES BISTADIO	PROGRESSIVE & MODULATING PROGRESSIVI E MODULANTI	kcal/h		kW		3F
		min	max	min	max	
GAS P 70/2	GAS P 70/M	350.000	650.000	135/407	756	
GAS P 100/2 *	GAS P 100/M *	500.000	1.000.000	200/581	1163	
GAS P 150/2 *	GAS P 150/M *	700.000	1.500.000	240/814	1744	

* Available also in Low NOx version
* Disponibili anche in versione Low NOx

FIRING RATES / OVERALL DIMENSIONS (mm) - CAMPO DI LAVORO / DIMENSIONI (mm)

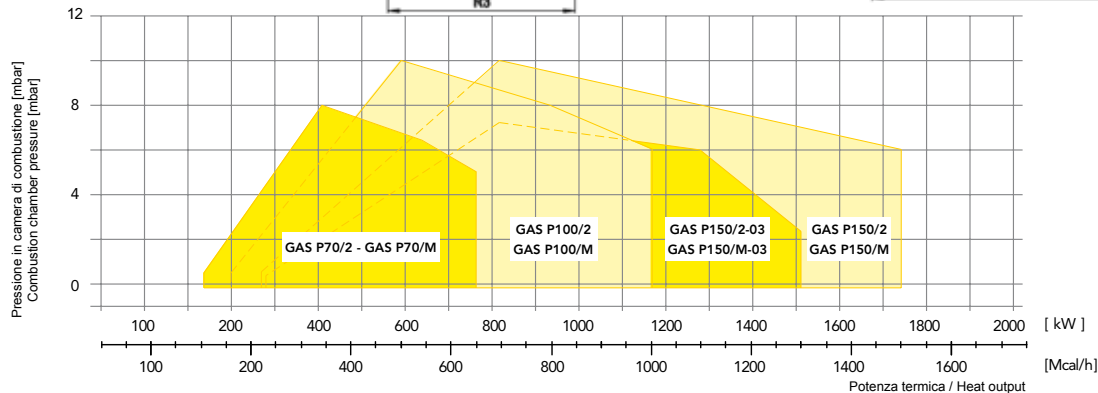
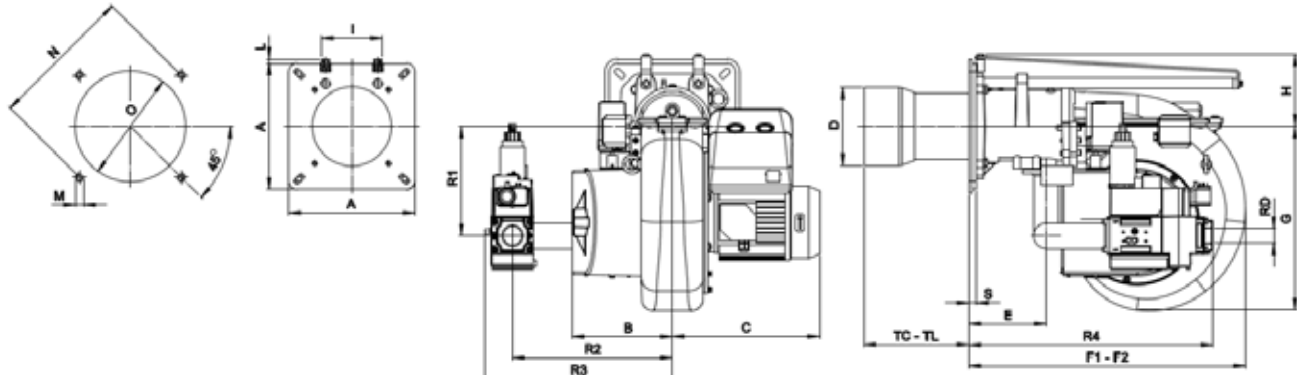

* Suggested/Consigliato

F2= overall dimension with the burner out in position of maintenance
F2= ingombro a bruciatore arretrato in posizione di manutenzione

MODEL MODELLO	A	B	C	D	E	F1	F2	G	H	I	L	M	N min	N max	O min*	O max	TC	TL	S	R1	R2	R3	R4	RD
GAS P 70/2 CE - D1" 1/4 - S	300	188	276	175	168	660	1100	327	171	144	10	M12	310	368	185	250	250	385	18	260	380	438	549	1" 1/4
GAS P 70/2 CE - D1" 1/2 - S	300	188	276	175	168	660	1100	327	171	144	10	M12	310	368	185	250	250	385	18	260	380	430	564	1" 1/2
GAS P 70/2 CE - D2" - S	300	188	276	175	168	660	1100	327	171	144	10	M12	310	368	185	250	250	385	18	260	380	430	564	2"
GAS P 100/2 CE - D1" 1/4 - S	300	238	350	185	184	660	1160	438	173	0	0	M12	340	368	195	250	250	385	18	260	380	438	549	1" 1/4
GAS P 100/2 CE - D1" 1/2 - S	300	238	350	185	184	660	1160	438	173	0	0	M12	340	368	195	250	250	385	18	260	380	430	564	1" 1/2
GAS P 100/2 CE - D2" - S	300	238	350	185	184	660	1160	438	173	0	0	M12	340	368	195	250	250	385	18	260	380	430	564	2"
GAS P 150/2 CE - D1" 1/2 - S	320	238	376	209	193	800	1380	438	213	183	40	M14	340	368	220	250	280	400	23	284	380	556	589	1" 1/2
GAS P 150/2 CE - D2" S	320	238	376	209	193	800	1380	438	213	183	40	M14	340	368	220	250	280	400	23	284	380	556	589	2"
GAS P 70/M CE - D1" 1/4 - S	300	331	362	175	168	660	1100	327	171	144	10	M12	310	368	185	250	250	385	18	260	415	473	513	1" 1/4
GAS P 70/M CE - D1" 1/2 - S	300	331	362	175	168	660	1100	327	171	144	10	M12	310	368	185	250	250	385	18	260	415	465	528	1" 1/2
GAS P 70/M CE - D2" - S	300	331	362	175	168	660	1100	327	171	144	10	M12	310	368	185	250	250	385	18	260	415	465	528	2"
GAS P 100/M CE - D1" 1/4 - S	300	376	372	185	184	660	1160	438	173	0	0	M12	340	368	195	250	250	385	18	260	460	520	529	1" 1/4
GAS P 100/M CE - D1" 1/2 - S	300	376	372	185	184	660	1160	438	173	0	0	M12	340	368	195	250	250	385	18	260	460	512	544	1" 1/2
GAS P 100/M CE - D2" - S	300	376	372	185	184	660	1160	438	173	0	0	M12	340	368	195	250	250	385	18	260	460	512	544	2"
GAS P 100/M CE - DN65-FS65	300	376	372	185	184	660	1160	438	173	0	0	M12	340	368	195	250	250	385	18	260	500	592	580	DN65
GAS P 150/M CE - D2" - S	320	376	372	209	193	800	1380	438	213	183	40	M14	340	368	220	250	280	400	23	228	510	685	540	2"
GAS P 150/M CE - DN65-FS65	320	376	372	209	193	800	1380	438	213	183	40	M14	340	368	220	250	280	400	23	228	510	688	590	DN65
GAS P 150/M CE - DN80-FS80	320	376	372	209	193	800	1380	438	213	183	40	M14	340	368	220	250	280	400	23	228	550	741	630	DN80



PROGRESSIVE & MODULATING PROGRESSIVI E MODULANTI	kcal/h		kW		⚡
	min	max	min	max	
GAS P 190/M* **	900.000	1.900.000	349/1046	2209	3F
GAS P 250/M* **	1.000.000	2.500.000	384/1163	2907	
GAS P 300/M* **	1.200.000	3.000.000	465/1395	3488	

- * Available also in Low NOx version
- * Disponibili anche in versione Low NOx
- ** Available also special versions with INVERTER and ELECTRONIC BURNER CONTROL
- ** Fornibili anche in versioni speciali con INVERTER e CAMMA ELETTRONICA

FIRING RATES / OVERALL DIMENSIONS (mm) - CAMPO DI LAVORO / DIMENSIONI (mm)

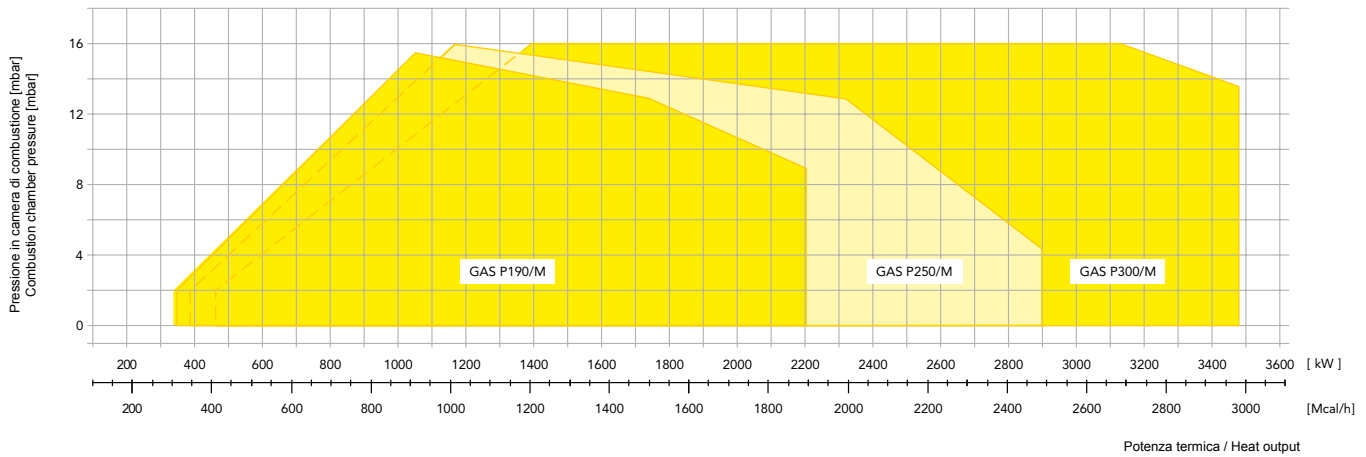
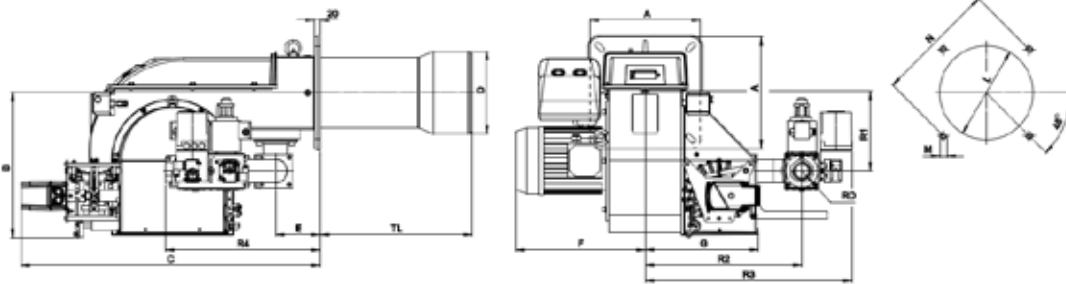

MODEL MODELLO	* Suggested/Consigliato																		
	A	B	C	D	E	F	G	TL	N min	N*	N max	L min*	L max	M	R1	R2	R3	R4	RD
GAS P 190/M CE - D2" - FS50	360	453	974	265	145	422	363	495	396	424	438	280	320	M14	254	509	672	504	2"
GAS P 190/M CE - DN65 - FS65	360	453	974	265	145	422	363	495	396	424	438	280	320	M14	254	480	634	688	DN65
GAS P 190/M CE - DN80 - FS80	360	453	974	265	145	422	363	495	396	424	438	280	320	M14	254	480	647	708	DN80
GAS P 190/M CE - DN100 - FS100	360	453	974	265	145	422	363	495	396	424	438	280	320	M14	254	480	654	748	DN100
GAS P 250/M CE - D2" - FS50	360	453	974	270	145	422	363	495	396	424	438	280	320	M14	254	509	672	504	2"
GAS P 250/M CE - DN65 - FS65	360	453	974	270	145	422	363	495	396	424	438	280	320	M14	254	480	634	688	DN65
GAS P 250/M CE - DN80 - FS80	360	453	974	270	145	422	363	495	396	424	438	280	320	M14	254	480	647	708	DN80
GAS P 250/M CE - DN100 - FS100	360	453	974	270	145	422	363	495	396	424	438	280	320	M14	254	480	654	748	DN100
GAS P 300/M CE - D2" - FS50	360	453	974	300	145	422	363	460	396	424	438	310	320	M14	254	590	672	504	2"
GAS P 300/M CE - DN65 - FS65	360	453	974	300	145	422	363	460	396	424	438	310	320	M14	254	480	634	688	DN65
GAS P 300/M CE - DN80 - FS80	360	453	974	300	145	422	363	460	396	424	438	310	320	M14	254	480	647	708	DN80
GAS P 300/M CE - DN100 - FS100	360	453	974	300	145	422	363	460	396	424	438	310	320	M14	254	480	654	748	DN100



PROGRESSIVE & MODULATING PROGRESSIVI E MODULANTI	kcal/h		kW		3F
	min	max	min	max	
GAS P 350/M* **	1.200.000	3.500.000	465/1395	4070	
GAS P 450/M* **	1.600.000	4.500.000	581/1860	5232	
GAS P 550/M* **	2.000.000	5.500.000	698/2325	6395	
GAS P 650/M **	3.000.000	6.500.000	1163/3488	7558	

- * Available also in Low NOx version
- * Disponibili anche in versione Low NOx
- ** Available also special versions with INVERTER and ELECTRONIC BURNER CONTROL
- ** Fornibili anche in versioni speciali con INVERTER e CAMMA ELETTRONICA

FIRING RATES / OVERALL DIMENSIONS (mm) - CAMPO DI LAVORO / DIMENSIONI (mm)

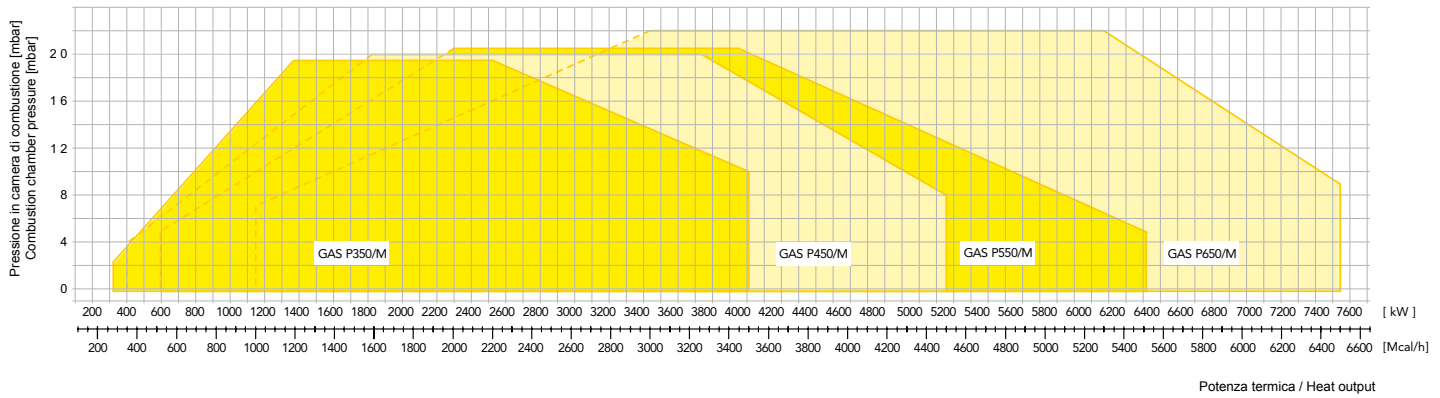
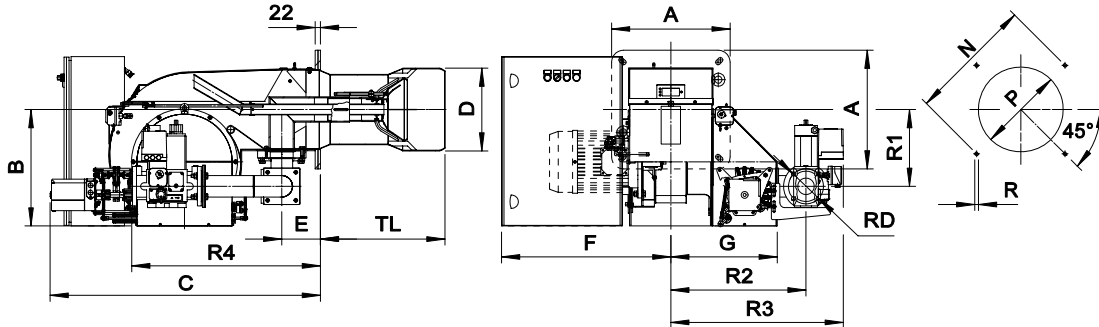

MODEL MODELLO	* Suggested/Consigliato																			
	A	B	C	D	E	F	G	TL	N min	N*	N max	P min	P*	P max	R	R1	R2	R3	R4	RD
GAS P 350/M CE - D2" - FS50	490	481	1118	342	160	600	440	515	552	552	580	350	360	450	M14	317	535	660	570	2"
GAS P 350/M CE - DN65 - FS65	490	481	1118	342	160	600	440	515	552	552	580	350	360	450	M14	317	560	714	780	DN65
GAS P 350/M CE - DN80 - FS80	490	481	1118	342	160	600	440	515	552	552	580	350	360	450	M14	317	560	727	800	DN80
GAS P 350/M CE - DN100 - FS100	490	481	1118	342	160	600	440	515	552	552	580	350	360	450	M14	317	590	765	840	DN100
GAS P 450/M CE - D2" - FS50	490	481	1118	382	160	600	440	520	552	552	580	390	400	450	M14	317	535	660	570	2"
GAS P 450/M CE - DN65 - FS65	490	481	1118	382	160	600	440	520	552	552	580	390	400	450	M14	317	560	714	780	DN65
GAS P 450/M CE - DN80 - FS80	490	481	1118	382	160	600	440	520	552	552	580	390	400	450	M14	317	560	727	800	DN80
GAS P 450/M CE - DN100 - FS100	490	481	1118	382	160	600	440	520	552	552	580	390	400	450	M14	317	590	765	840	DN100
GAS P 550/M CE - D2" - FS50	490	481	1118	402	160	661	440	520	552	552	580	410	420	450	M14	317	535	660	570	2"
GAS P 550/M CE - DN65 - FS65	490	481	1118	402	160	661	440	520	552	552	580	410	420	450	M14	317	560	714	780	DN65
GAS P 550/M CE - DN80 - FS80	490	481	1118	402	160	661	440	520	552	552	580	410	420	450	M14	317	560	727	800	DN80
GAS P 550/M CE - DN100 - FS100	490	481	1118	402	160	661	440	520	552	552	580	410	420	450	M14	317	590	765	840	DN100
GAS P 650/M CE - DN65 - FS65	490	481	1118	420	160	700	440	490	552	552	580	430	440	450	M14	317	560	714	780	DN65
GAS P 650/M CE - DN80 - FS80	490	481	1118	420	160	700	440	490	552	552	580	430	440	450	M14	317	560	727	800	DN80
GAS P 650/M CE - DN100 - FS100	490	481	1118	420	160	700	440	490	552	552	580	430	440	450	M14	317	590	765	840	DN100



PROGRESSIVE & MODULATING PROGRESSIVI E MODULANTI	kcal/h		kW		3F
	min	max	min	max	
GAS P 750/M MEC *	3.400.000	7.500.000	1395/3953	8721	
GAS P 1000/M MEC *	3.400.000	10.000.000	1395/3953	11628	
GAS P 1300/M MEC *	3.600.000	11.500.000	1977/4186	13372	
GAS P 1500/M MEC *	3.600.000	13.000.000	1977/4186	15116	
GAS P 1800/M MEC *	5.000.000	15.000.000	2325/5814	17442	

* Versions with MECHANICAL CAM
* Versioni con CAMMA MECCANICA

FIRING RATES / OVERALL DIMENSIONS (mm) - CAMPO DI LAVORO / DIMENSIONI (mm)

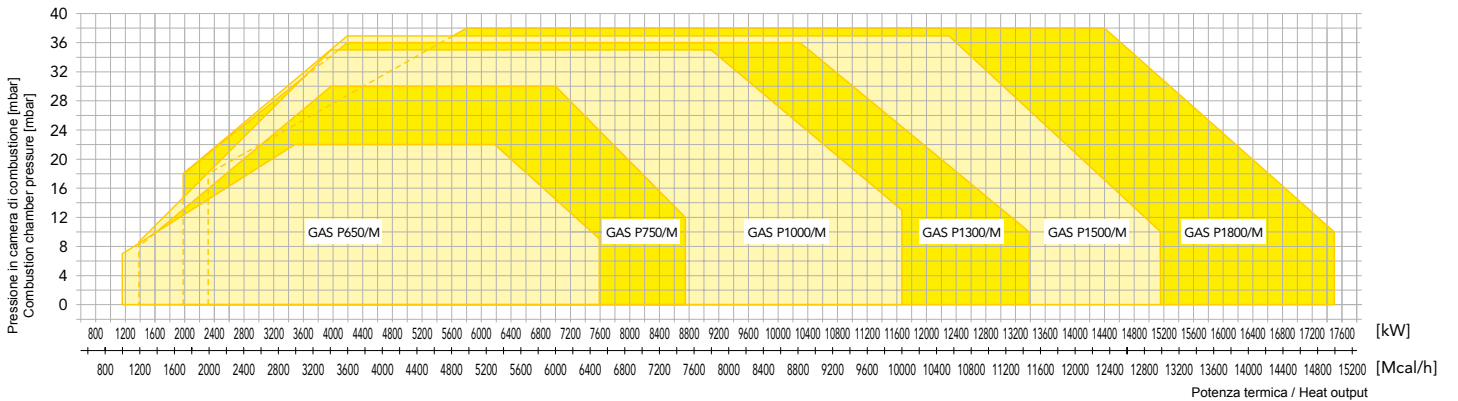

Please contact our Technical & Sales Offices for detailed technical data.

Vi invitiamo a contattare i ns. Uffici Tecnico-Commerciali per i dati tecnici di dettaglio.



PROGRESSIVE & MODULATING PROGRESSIVI E MODULANTI	kcal/h		kW		3F
	min	max	min	max	
GAS P 750/M EL *	3.400.000	7.500.000	1395/3953	8721	
GAS P 1000/M EL *	3.400.000	10.000.000	1395/3953	11628	
GAS P 1300/M EL *	3.600.000	11.500.000	1977/4186	13372	
GAS P 1500/M EL *	3.600.000	13.000.000	1977/4186	15116	
GAS P 1800/M EL *	5.000.000	15.000.000	2325/5814	17442	

* Versions with ELECTRONIC CAM
* Versioni con CAMMA ELETTRONICA

FIRING RATES / OVERALL DIMENSIONS (mm) - CAMPO DI LAVORO / DIMENSIONI (mm)

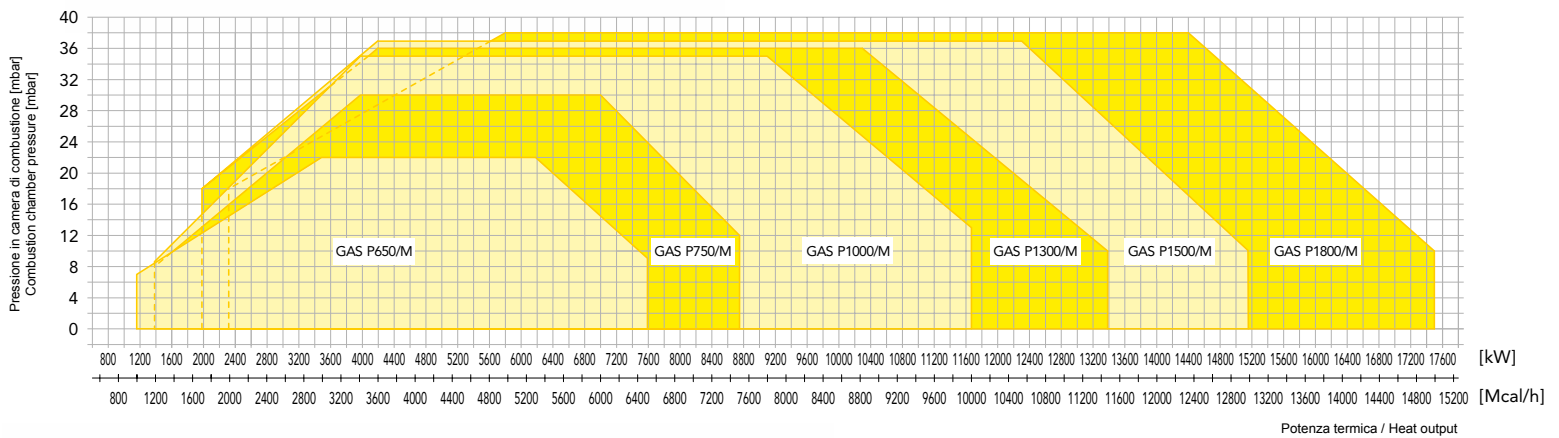

Please contact our Technical & Sales Offices for detailed technical data.

Vi invitiamo a contattare i ns. Uffici Tecnico-Commerciali per i dati tecnici di dettaglio.



**DUAL FUEL BURNERS
GAS/LIGHT OIL
GAS/HEAVY OIL KN
BRUCIATORI MISTI
GAS/GASOLIO
GAS/OLIO COMBUSTIBILE KN**



4



Gas/Light Oil - Gas/Gasolio



1 STAGE MONOSTADIO	kcal/h		kW		
	min	max	min	max	
GM X 0	19.500	29.500	22,6	34,3	1F
GM X 1	25.000	60.000	29	69,8	
GM X 3	50.000	130.000	58,1	151	
GM X 4	100.000	200.000	116	232	

FIRING RATES / OVERALL DIMENSIONS (mm) - CAMPO DI LAVORO / DIMENSIONI (mm)

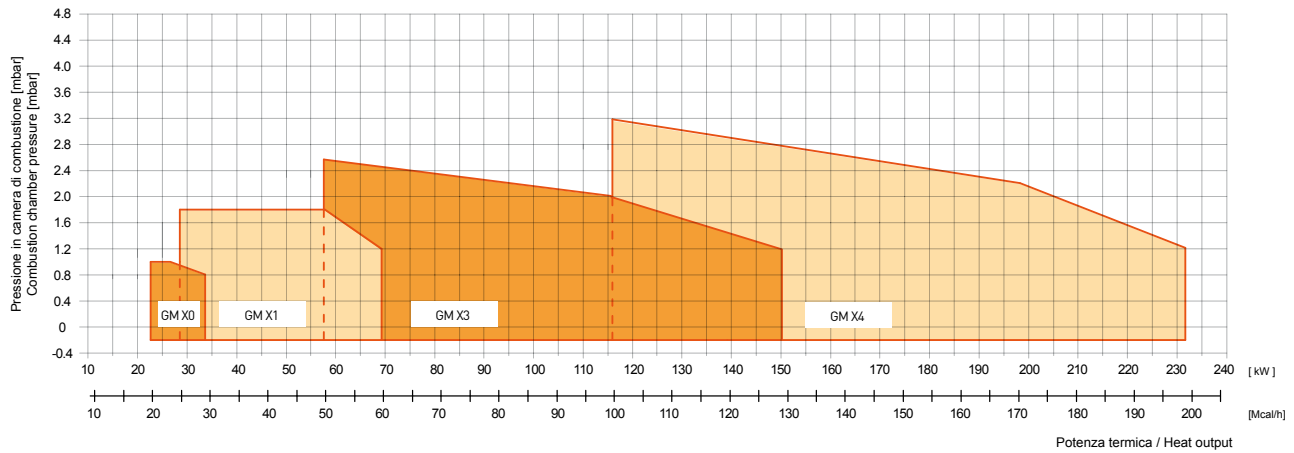
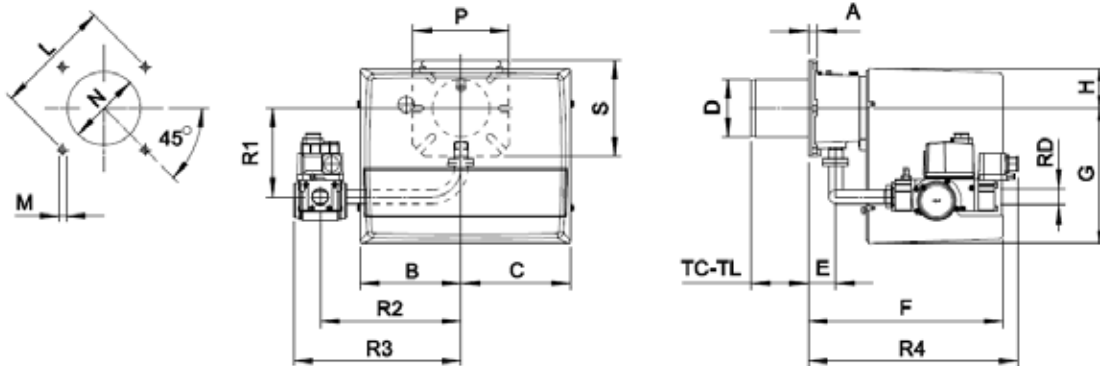

MODEL MODELLO	* Suggested/Consigliato																							
	A	B	C	D	E	F	G	H	L min	L*	L max	M	N min	N*	N max	P	S	TC	TL	R1	R2	R3	R4	RD
GM X 0 - D1/2" - S	15	162	175	90	43	305	210	65	130	150	170	M8	100	110	130	150	150	90	150	132	200	254	240	1/2"
GM X 1 - D1/2" - S	15	162	175	90	43	305	210	65	130	150	170	M8	100	110	130	150	150	90	150	132	200	254	240	1/2"
GM X 1 - D3/4" - S	15	162	175	90	43	305	210	65	130	150	170	M8	100	110	130	150	150	90	150	138	220	262	328	3/4"
GM X 3 - D1" - S	16	185	195	108	54	340	248	70	150	170	170	M8	120	130	140	190	150	130	250	168	280	337	361	1"
GM X 4 - D1" - S	20	185	195	125	78	368	248	70	170	205	226	M10	130	140	160	200	200	160	280	173	280	337	385	1"

Gas/Light Oil - Gas/Gasolio



2 STAGES BISTADIO	PROGRESSIVE & MODULATING	kcal/h		kW		
		min	max	min	max	
K 3/2	-	100.000	200.000	63,9/116	232	1F
K 4/2	-	200.000	450.000	116/232	523	3F
K 5/2	-	350.000	650.000	135/407	756	
K 6/2	K 6/M	500.000	1.000.000	200/581	1163	
K 7/2	K 7/M	700.000	1.300.000	279/814	1511	

FIRING RATES / OVERALL DIMENSIONS (mm) - CAMPO DI LAVORO / DIMENSIONI (mm)

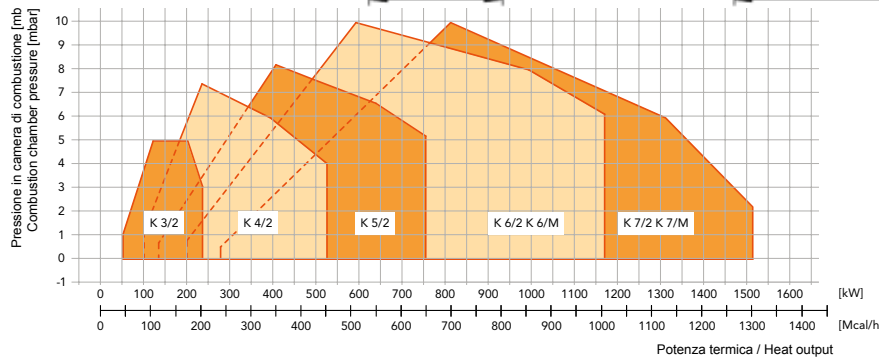
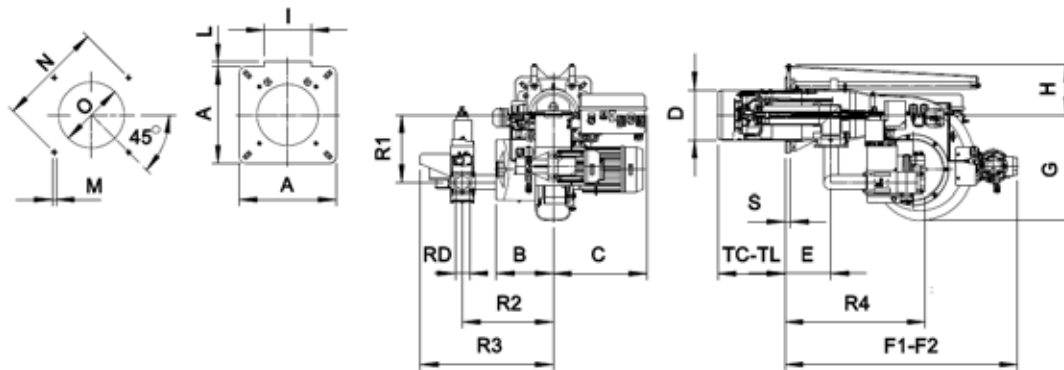

* Suggested/Consigliato

MODEL MODELLO	A	B	C	D	E	F1	F2	G	H	I	L	M	N min	N max	o min*	o max	TC	TL	S	R1	R2	R3	R4	RD
K 3/2 - D1" - S	200	188	358	138	98	493	-	327	110	0	0	M10	205	226	150	-	250	350	18	171	280	411	354	1"
K 4/2 - D1" - S	200	188	358	150	98	493	-	327	110	0	0	M10	205	226	160	-	250	350	18	171	280	411	354	1"
K 4/2 - D1" 1/2 - FS40	200	188	358	150	98	493	-	327	110	0	0	M10	205	226	160	-	250	350	18	203	280	432	456	1" 1/2
K 4/2 - D1" 1/2 - FS50	200	188	358	150	98	493	-	327	110	0	0	M10	205	226	160	-	250	350	18	203	280	432	456	1" 1/2
K 5/2 - D1" - S	300	236	365	175	168	840	1280	327	171	144	10	M12	310	368	185	250	250	315	18	260	380	438	548	1"
K 5/2 - D1" 1/4 - S	300	236	365	175	168	840	1280	327	171	144	10	M12	310	368	185	250	250	315	18	260	380	438	548	1" 1/4
K 5/2 - D1" 1/2 - S	300	236	365	175	168	840	1280	327	171	144	10	M12	310	368	185	250	250	315	18	260	380	430	564	1" 1/2
K 5/2 - D2" - S	300	236	365	175	168	840	1280	327	171	144	10	M12	310	368	185	250	250	315	18	260	380	430	564	2"
K 6/2 - D2" - S	320	238	393	210	193	980	1560	438	213	183	40	M14	340	368	220	250	280	400	23	283	380	556	588	2"
K 7/2 - D2" - S	320	238	393	210	193	980	1560	438	213	183	40	M14	340	368	220	250	280	400	23	283	380	556	588	2"
K 6/M - D2" - FS50	320	380	393	209	193	1037	1617	438	267	183	40	M14	340	368	220	250	280	400	23	228	510	673	552	2"
K 6/M - DN65 - FS65	320	380	393	209	193	1037	1617	438	267	183	40	M14	340	368	220	250	280	400	23	228	510	665	586	DN65
K 6/M - DN80 - FS80	320	380	393	209	193	1037	1617	438	267	183	40	M14	340	368	220	250	280	400	23	228	550	720	626	DN80
K 7/M - D2" - FS50	320	380	393	209	193	1037	1617	438	267	183	40	M14	340	368	220	250	280	400	23	228	510	673	552	2"
K 7/M - DN65 - FS65	320	380	393	209	193	1037	1617	438	267	183	40	M14	340	368	220	250	280	400	23	228	510	665	586	DN65
K 7/M - DN80 - FS80	320	380	393	209	193	1037	1617	438	267	183	40	M14	340	368	220	250	280	400	23	228	550	720	626	DN80

Gas/Light Oil - Gas/Gasolio



PROGRESSIVE & MODULATING PROGRESSIVI E MODULANTI	kcal/h		kW		3F
	min	max	min	max	
K 190/M* **	900.000	2.019.000	349/1046	2395	3F
K 250/M* **	1.000.000	2.500.000	465/1163	2907	

- * Available also in Low NOx version
- * Disponibili anche in versione Low NOx
- ** Available also special versions with INVERTER and ELECTRONIC BURNER CONTROL
- ** Fornibili anche in versioni speciali con INVERTER e CAMMA ELETTRONICA

FIRING RATES / OVERALL DIMENSIONS (mm) - CAMPO DI LAVORO / DIMENSIONI (mm)

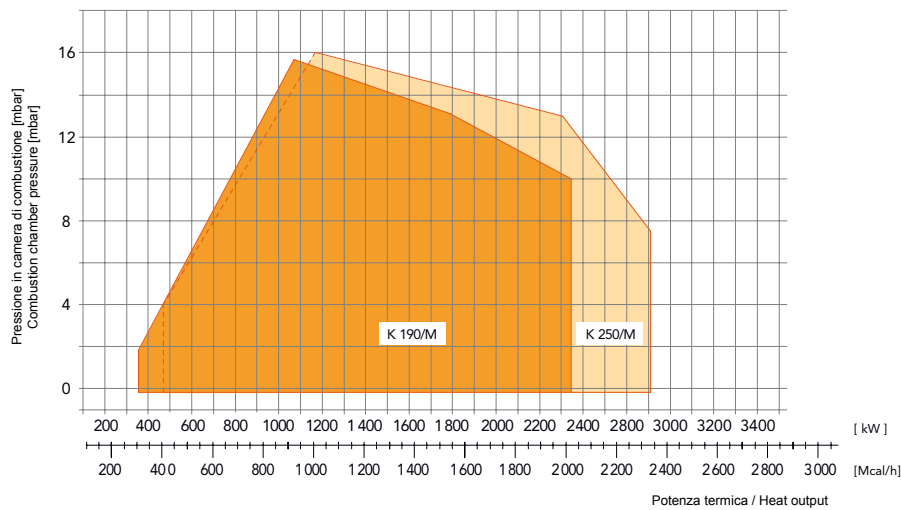
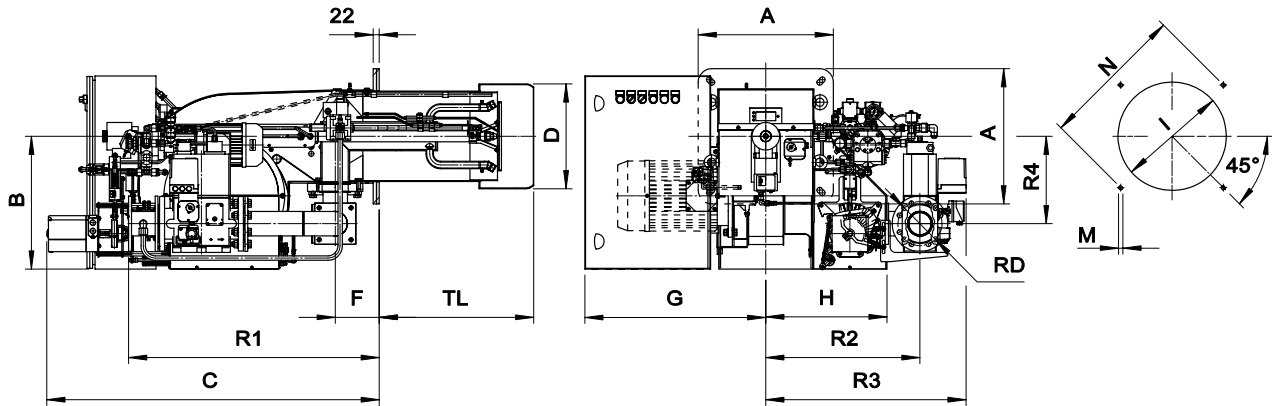

MODEL MODELLO	A	B	C	D	TL	F	G	H	I min	I*	I max	M	N min	N*	N max	R1	R2	R3	R4	RD
K 190/M - D2" - FS50	360	453	1100	265	481	145	545	363	280	280	320	M14	396	424	438	604	509	672	254	2"
K 190/M - DN65 - FS65	360	453	1100	265	481	145	545	363	280	280	320	M14	396	424	438	788	480	634	254	DN65
K 190/M - DN80 - FS80	360	453	1100	265	481	145	545	363	280	280	320	M14	396	424	438	808	480	647	254	DN80
K 190/M - DN100 - FS100	360	453	1100	265	481	145	545	363	280	280	320	M14	396	424	438	848	480	654	254	DN100
K 250/M - D2" - FS50	360	453	1100	265	481	145	545	363	280	280	320	M14	396	424	438	604	509	672	254	2"
K 250/M - DN65 - FS65	360	453	1100	265	481	145	545	363	280	280	320	M14	396	424	438	788	480	634	254	DN65
K 250/M - DN80 - FS80	360	453	1100	265	481	145	545	363	280	280	320	M14	396	424	438	808	480	647	254	DN80
K 250/M - DN100 - FS100	360	453	1100	265	481	145	545	363	280	280	320	M14	396	424	438	848	480	654	254	DN100

* Suggested/Consigliato

Gas/Light Oil - Gas/Gasolio



PROGRESSIVE & MODULATING PROGRESSIVI E MODULANTI	kcal/h		kW		3F
	min	max	min	max	
K 350/M* **	1.200.000	3.500.000	465/1395	4070	3F
K 450/M* **	1.600.000	4.500.000	581/1860	5232	
K 550/M* **	2.000.000	5.500.000	698/2325	6395	

- * Available also in Low NOx version
- * Disponibili anche in versione Low NOx
- ** Available also special versions with INVERTER and ELECTRONIC BURNER CONTROL
- ** Fornibili anche in versioni speciali con INVERTER e CAMMA ELETTRONICA

FIRING RATES / OVERALL DIMENSIONS (mm) - CAMPO DI LAVORO / DIMENSIONI (mm)

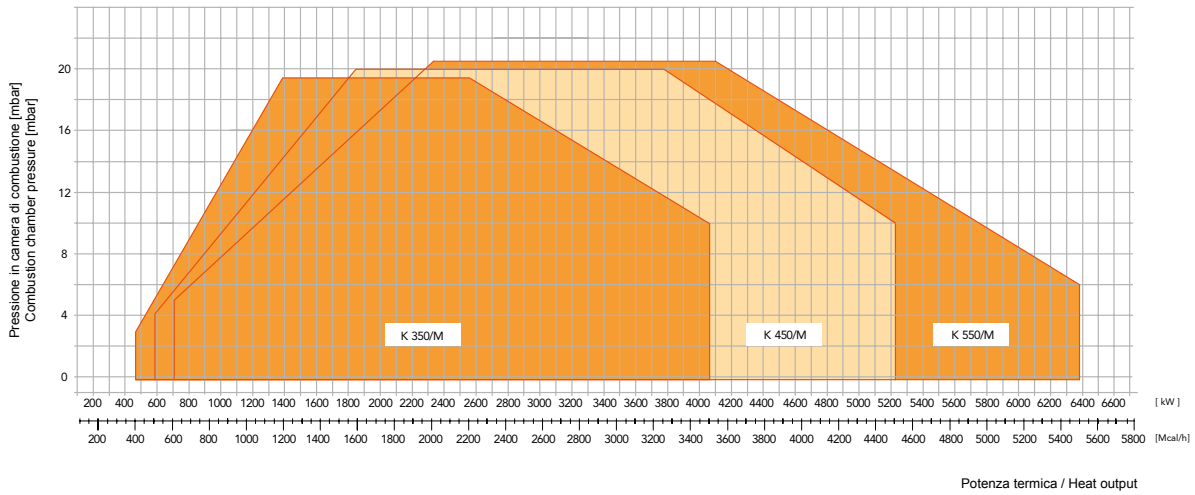
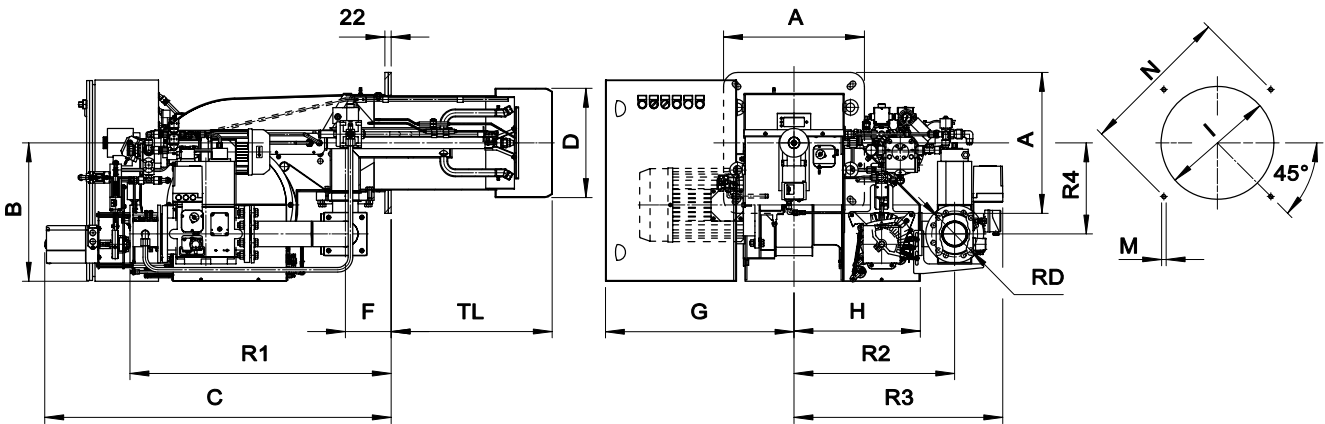

MODEL MODELLO	A	B	C	D	TL	F	G	H	I min	I*	I max	M	min	N*	max	R1	R2	R3	R4	RD
K 350/M - D2" - FS50	490	481	1206	334	535	160	600	440	350	350	450	M14	552	552	580	670	535	664	317	D2"
K 350/M - DN65 - FS65	490	481	1206	334	535	160	600	440	350	350	450	M14	552	552	580	880	560	715	317	DN65
K 350/M - DN80 - FS80	490	481	1206	334	535	160	600	440	350	350	450	M14	552	552	580	900	560	730	317	DN80
K 350/M - DN100 - FS100	490	481	1206	334	535	160	600	440	350	350	450	M14	552	552	580	940	590	765	317	DN100
K 450/M - D2" - FS50	490	481	1206	380	560	160	600	440	390	390	450	M14	552	552	580	670	535	664	317	D 2"
K 450/M - DN65 - FS65	490	481	1206	380	560	160	600	440	390	390	450	M14	552	552	580	880	560	715	317	DN65
K 450/M - DN80 - FS80	490	481	1206	380	560	160	600	440	390	390	450	M14	552	552	580	900	560	730	317	DN80
K 450/M - DN100 - FS100	490	481	1206	380	560	160	600	440	390	390	450	M14	552	552	580	940	590	765	317	DN100
K 550/M - D2" - FS50	490	481	1206	380	560	160	661	440	390	410	450	M14	552	552	580	670	535	664	317	D2"
K 550/M - DN65 - FS65	490	481	1206	380	560	160	661	440	390	410	450	M14	552	552	580	880	560	715	317	DN65
K 550/M - DN80 - FS80	490	481	1206	380	560	160	661	440	390	410	450	M14	552	552	580	900	560	730	317	DN80
K 550/M - DN100 - FS100	490	481	1206	380	560	160	661	440	390	410	450	M14	552	552	580	940	590	765	317	DN100

* Suggested/Consigliato

Gas/Light Oil - Gas/Gasolio



PROGRESSIVE & MODULATING PROGRESSIVI E MODULANTI	kcal/h		kW		3F
	min	max	min	max	
K 650/M *	3.000.000	6.500.000	1163/3488	7558	
K 750/M *	3.400.000	7.500.000	1395/3953	8721	
K 1000/M *	3.400.000	10.000.000	1395/3953	11628	
K 1300/M *	3.600.000	11.500.000	1977/4186	13372	
K 1500/M *	3.600.000	13.000.000	1977/4186	15116	
K 1800/M *	5.000.000	15.000.000	2325/5815	17442	

* Available also versions with INVERTER and ELECTRONIC BURNER CONTROL
 * Fornibili anche in versioni speciali con INVERTER e CAMMA ELETTRONICA

FIRING RATES / OVERALL DIMENSIONS (mm) - CAMPO DI LAVORO / DIMENSIONI (mm)

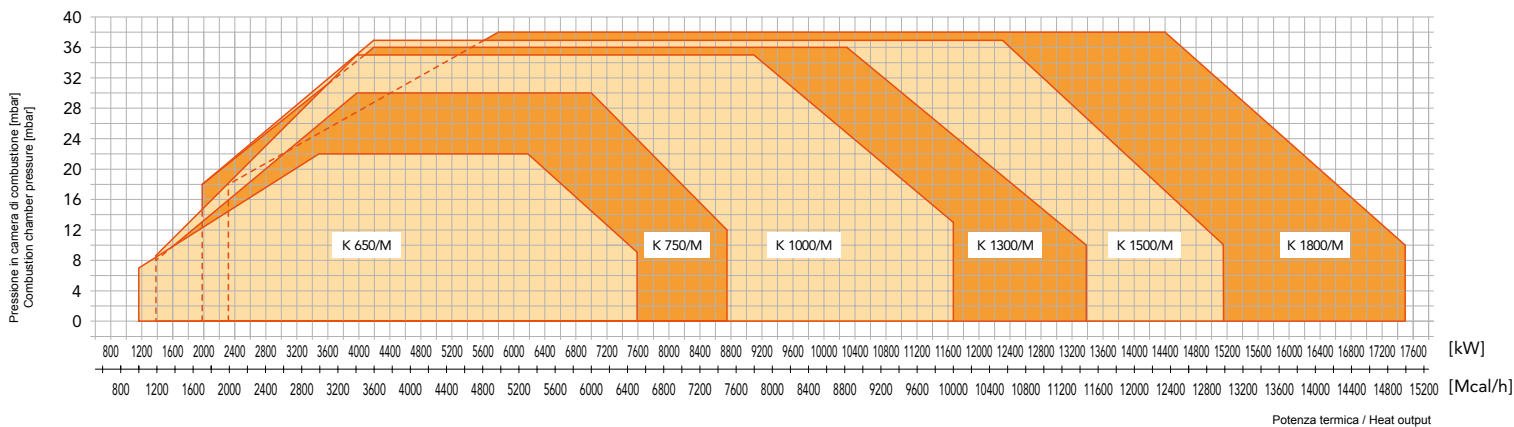

Please contact our Technical & Sales Offices for detailed technical data.

Vi invitiamo a contattare i ns. Uffici Tecnico-Commerciali per i dati tecnici di dettaglio.

Gas/Heavy oil - Gas/Olio Combustibile



PROGRESSIVE & MODULATING PROGRESSIVI E MODULANTI	kcal/h		kW		⚡
	min	max	min	max	
KN 190/M *	900.000	2.019.000	349/1046	2347	3F
KN 250/M *	1.000.000	2.500.000	465/1163	2907	
KN 350/M *	1.200.000	3.500.000	465/1395	4070	
KN 450/M *	1.600.000	4.500.000	581/1860	5232	
KN 550/M *	2.000.000	5.500.000	698/2325	6395	

* Available also versions with INVERTER and ELECTRONIC BURNER CONTROL
* Fornibili anche in versioni speciali con INVERTER e CAMMA ELETTRONICA

FIRING RATES / OVERALL DIMENSIONS (mm) - CAMPO DI LAVORO / DIMENSIONI (mm)

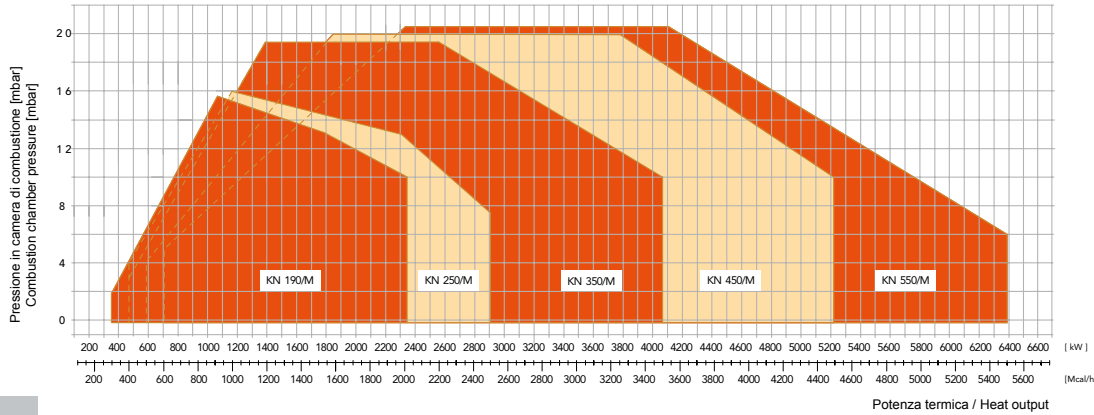
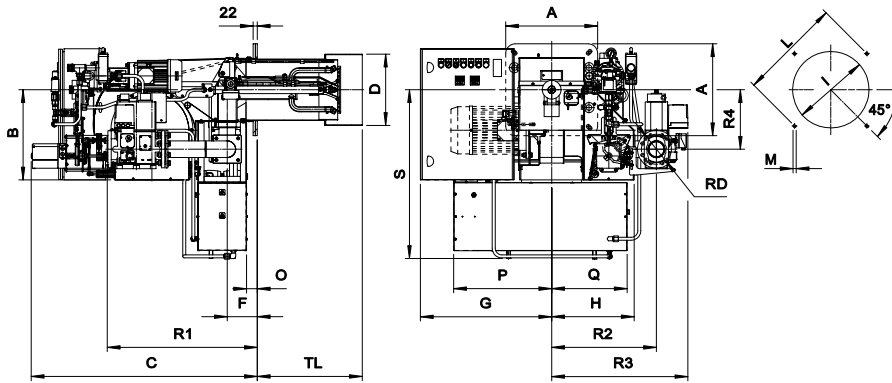

MODEL MODELLO	A	B	C	D	F	G	H	I min	I*	I max	L min	L*	L max	M14	O	P	Q	S	TL	R1	R2	R3	R4	RD
	KN 190/M - D2" - FS50	360	453	1100	265	145	545	363	280	280	320	396	424	438	M14	93	403	403	790	480	504	509	672	260
KN 190/M - DN65 - FS65	360	453	1100	265	145	545	363	280	280	320	396	424	438	M14	93	403	403	790	480	688	480	634	260	DN65
KN 190/M - DN80 - FS80	360	453	1100	265	145	545	363	280	280	320	396	424	438	M14	93	403	403	790	480	708	480	648	260	DN80
KN 190/M - DN100 - FS100	360	453	1100	265	145	545	363	280	280	320	396	424	438	M14	93	403	403	790	480	748	480	655	260	DN100
KN 250/M - D2" - FS50	360	453	1100	265	145	545	363	280	280	320	396	424	438	M14	93	403	403	790	480	504	509	672	260	2"
KN 250/M - DN65 - FS65	360	453	1100	265	145	545	363	280	280	320	396	424	438	M14	93	403	403	790	480	688	480	634	260	DN65
KN 250/M - DN80 - FS80	360	453	1100	265	145	545	363	280	280	320	396	424	438	M14	93	403	403	790	480	708	480	648	260	DN80
KN 250/M - DN100 - FS100	360	453	1100	265	145	545	363	280	280	320	396	424	438	M14	93	403	403	790	480	748	480	655	260	DN100
KN 350/M - D2" - FS50	490	481	1206	334	160	600	440	350	350	450	552	552	580	M14	57	523	405	762	535	570	535	648	317	2"
KN 350/M - DN65 - FS65	490	481	1206	334	160	600	440	350	350	450	552	552	580	M14	57	523	405	762	535	780	560	713	317	DN65
KN 350/M - DN80 - FS80	490	481	1206	334	160	600	440	350	350	450	552	552	580	M14	57	523	405	762	535	800	560	726	317	DN80
KN 350/M - DN100 - FS100	490	481	1206	334	160	600	440	350	350	450	552	552	580	M14	57	523	405	762	535	840	560	764	317	DN100
KN 450/M - D2" - FS50	490	481	1206	380	160	700	440	390	390	450	552	552	580	M14	57	523	405	905	560	570	535	648	317	2"
KN 450/M - DN65 - FS65	490	481	1206	380	160	700	440	390	390	450	552	552	580	M14	57	523	405	905	560	780	560	713	317	DN65
KN 450/M - DN80 - FS80	490	481	1206	380	160	700	440	390	390	450	552	552	580	M14	57	523	405	905	560	800	560	726	317	DN80
KN 450/M - DN100 - FS100	490	481	1206	380	160	700	440	390	390	450	552	552	580	M14	57	523	405	905	560	840	560	764	317	DN100
KN 550/M - D2" - FS50	490	481	1206	380	160	700	440	390	410	450	552	552	580	M14	57	523	405	905	560	570	535	648	317	2"
KN 550/M - DN65 - FS65	490	481	1206	380	160	700	440	390	410	450	552	552	580	M14	57	523	405	905	560	780	560	713	317	DN65
KN 550/M - DN80 - FS80	490	481	1206	380	160	700	440	390	410	450	552	552	580	M14	57	523	405	905	560	800	560	726	317	DN80
KN 550/M - DN100 - FS100	490	481	1206	380	160	700	440	390	410	450	552	552	580	M14	57	523	405	905	560	840	560	764	317	DN100

* Suggested/Consigliato

Gas/Heavy oil - Gas/Olio Combustibile



PROGRESSIVE & MODULATING PROGRESSIVI E MODULANTI	kcal/h		kW		⚡
	min	max	min	max	
KN 650/M *	3.000.000	6.500.000	1163/3488	7558	3F
KN 750/M *	3.400.000	7.500.000	1395/3953	8721	
KN 1000/M *	3.400.000	10.000.000	1395/3953	11628	
KN 1300/M *	3.600.000	11.500.000	1977/4186	13372	
KN 1500/M *	3.600.000	13.000.000	1977/4186	15116	
KN 1800/M *	5.000.000	15.000.000	2325/5814	17442	

* Available also versions with INVERTER and ELECTRONIC BURNER CONTROL
 * Fornibili anche in versioni speciali con INVERTER e CAMMA ELETTRONICA

FIRING RATES / OVERALL DIMENSIONS (mm) - CAMPO DI LAVORO / DIMENSIONI (mm)

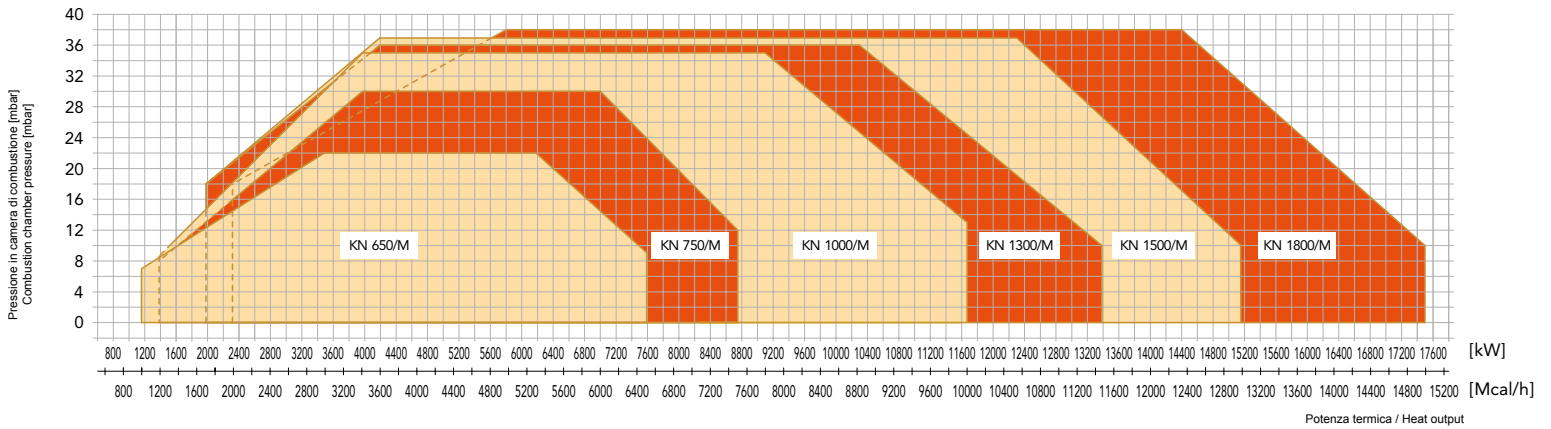

Please contact our Technical & Sales Offices for detailed technical data.

Vi invitiamo a contattare i ns. Uffici Tecnico-Commerciali per i dati tecnici di dettaglio.

Industrial burners are designed for residential plants and industrial processes that need high heating powers. The actual range is characterized by duo block burners with separated ventilator to be installed based on specific and real technical needs (ventilator not included).

When a significant amount of heating is needed, a single ventilator is able to work for more industrial burners, simplifying the entire heating plant. It's possible to use pre-heated combustion air, taking advantage of heat recovery from flue gases.

Available for the use of different types of fuel (light oil, heavy oil, natural gas, LPG), the industrial burners can be customized based on final plant characteristics and Your real needs.

Thanks to last technical innovations, the industrial burners are easy to be installed. Available both mechanical and electronic version.

Please contact our Technical & Sales Offices for the study of Your specific needs.

Le testate industriali sono progettate per impianti civili e processi industriali che richiedono grandi potenze termiche. La gamma sviluppata si caratterizza per la predisposizione all'installazione del ventilatore dissociato, da abbinare separatamente sulla base delle specifiche tecniche.

Nelle situazioni di rilevante fabbisogno termico, un singolo ventilatore può asservire più testate industriali, conseguendo la semplificazione dell'impianto. È possibile impiegare aria comburente preriscaldata, sfruttando il recupero termico proveniente dai gas di scarico della caldaia.

Disponibili per l'utilizzo dei diversi tipi di combustibile (gasolio, olio combustibile, gas metano, G.P.L.), sono personalizzabili in funzione delle caratteristiche dell'impianto finale e delle Vostre reali esigenze.

Le recenti innovazioni rendono le testate industriali di facile installazione. Disponibili anche nella versione con camma meccanica e camma elettronica.

Vi invitiamo a contattare i ns. Uffici Tecnico-Commerciali per lo studio delle Vostre applicazioni specifiche.

INDUSTRIAL BURNERS

BRUCIATORI INDUSTRIALI

5

LIGHT OIL BURNERS / BRUCIATORI DI GASOLIO



MODEL MODELLO	kg/h		kW		⚡
	min	max	min	max	
HI-FGP 190/M TL	60	206	712	2443	3F
HI-FGP 250/M TL	80	250	949	2965	
HI-FGP 350/M TL	120	350	1423	4151	
HI-FGP 450/M TL	160	450	1898	5337	
HI-FGP 550/M TL	200	550	2372	6523	
HI-FGP 650/M TL	294	637	3488	7558	
HI-FGP 750/M TL	333	735	3953	8721	
HI-FGP 1000/M TL	333	980	3953	11628	
HI-FGP 1300/M TL	353	1127	4186	13372	
HI-FGP 1500/M TL	353	1274	4186	15116	
HI-FGP 1800/M TL	490	1471	5814	17442	



HEAVY OIL BURNER / BRUCIATORI DI OLIO COMBUSTIBILE

MODEL MODELLO	kg/h		kW		⚡
	min	max	min	max	
HI-FNDP 190/M TL	80	206	911	2347	3F
HI-FNDP 250/M TL	100	250	1139	2849	
HI-FNDP 350/M TL	120	350	1367	3988	
HI-FNDP 450/M TL	160	450	1823	5128	
HI-FNDP 550/M TL	200	550	2279	6267	
HI-FNDP 650/M TL	306	663	3488	7558	
HI-FNDP 750/M TL	347	765	3953	8721	
HI-FNDP 1000/M TL	347	1020	3953	11628	
HI-FNDP 1300/M TL	367	1173	4186	13372	
HI-FNDP 1500/M TL	367	1326	4186	15116	
HI-FNDP 1800/M TL	510	1531	5814	17442	



GAS BURNERS / BRUCIATORI DI GAS

MODEL MODELLO	kcal/h		kW		⚡
	min	max	min	max	
HI-GAS P190/M CE TL	900.000	1.900.000	1046	2209	3F
HI-GAS P250/M CE TL	1.000.000	2.500.000	1163	2907	
HI-GAS P300/M CE TL	1.200.000	3.000.000	1395	3488	
HI-GAS P350/M CE TL	1.200.000	3.500.000	1395	4070	
HI-GAS P450/M CE TL	1.600.000	4.500.000	1850	5232	
HI-GAS P550/M CE TL	2.000.000	5.500.000	2325	6395	
HI-GAS P650/M CE TL	3.000.000	6.500.000	3488	7558	
HI-GAS P750/M CE TL	3.400.000	7.500.000	3953	8721	
HI-GAS P1000/M CE TL	3.400.000	10.000.000	3953	11628	
HI-GAS P1300/M CE TL	3.600.000	11.500.000	4186	13372	
HI-GAS P1500/M CE TL	3.600.000	13.000.000	4186	15116	
HI-GAS P1800/M CE TL	5.000.000	15.000.000	5814	17442	



DUAL FUEL BURNERS / BRUCIATORI MISTI

GAS / LIGHT OIL GAS / GASOLIO	kcal/h		kW		⚡
	min	max	min	max	
HI-K 190/M TL	900.000	2.060.000	1046	2395	3F
HI-K 250/M TL	900.000	2.500.000	1163	2907	
HI-K 350/M TL	1.200.000	3.500.000	1395	4070	
HI-K 450/M TL	1.600.000	4.500.000	1860	5232	
HI-K 550/M TL	2.000.000	5.500.000	2325	6395	
HI-K 650/M TL	3.000.000	6.500.000	3488	7558	
HI-K 750/M TL	3.400.000	7.500.000	3953	8721	
HI-K 1000/M TL	3.400.000	10.000.000	3953	11628	
HI-K 1300/M TL	3.600.000	11.500.000	4186	13372	
HI-K 1500/M TL	3.600.000	13.000.000	4186	15116	
HI-K 1800/M TL	5.000.000	15.000.000	5814	17442	

GAS / HEAVY OIL GAS / OLIO COMBUSTIBILE	kcal/h		kW		⚡
	min	max	min	max	
HI-KN 190/M TL	900.000	2.060.000	1046	2395	3F
HI-KN 250/M TL	900.000	2.500.000	1163	2907	
HI-KN 350/M TL	1.200.000	3.500.000	1395	4070	
HI-KN 450/M TL	1.600.000	4.500.000	1860	5232	
HI-KN 550/M TL	2.000.000	5.500.000	2325	6395	
HI-KN 650/M TL	3.000.000	6.500.000	3488	7558	
HI-KN 750/M TL	3.400.000	7.500.000	3953	8721	
HI-KN 1000/M TL	3.400.000	10.000.000	3953	11628	
HI-KN 1300/M TL	3.600.000	11.500.000	4186	13372	
HI-KN 1500/M TL	3.600.000	13.000.000	4186	15116	
HI-KN 1800/M TL	5.000.000	15.000.000	5814	17442	

The illustrations and data here shown are indicative. Being constantly involved in the continuous improvement of the whole production range, F.B.R. Bruciatori S.r.l. reserves the right to bring, without any obligation of warning, any changes that would be appropriate to the continuing development of their products. Le illustrazioni e i dati riportati sono indicativi. Essendo F.B.R. Bruciatori S.r.l. costantemente impegnata nel continuo perfezionamento di tutta la produzione, si riserva il diritto di apportare, senza obbligo di preavviso, tutte le modifiche che riterrà più opportune, per l'evoluzione dei propri prodotti.



F.B.R. BRUCIATORI S.r.l.

Via V. Veneto, 152 _ 37050 Angiari (VR) _ Italy

Tel. +39 0442 97000 _ Fax +39 0442 97299

www.fbr.it

email: fbr@fbr.it