



Product summary

emcotherm **cassette fancoils**

Models DKK 03 – DKK 16

emcobad

emcobau

emcoklima





Model DKK cassette fancoils with forced convection cooling or heating, cooling or ventilation. 2-pipe-system with primary air connection.



emcotherm **model DKK**

emcotherm DKK cassette fancoils complete the range of indoor climate systems available from emco and are the perfect addition to emcotherm floor and cabinet convectors as well as chilled beams.

Their compact design, which has been specifically tailored for conformity to the standard Euroraster system, has a virtual invisible installation in suspended ceilings.

The attractively designed air inlet grille and the outlet lamellae are the only visible components.

The range covers cassette fancoils offering various capacity levels with panel dimensions of (L x W) 650 x 650 mm in the case of individual panels (DKK03 - DKK08) or 650 x 1220 mm in the case of double panels (DKK09 - DKK16).

Two ¾" female connections positioned at the side are responsible for supplying the cooled or heated water to the unit. The cold water ceiling panels are controlled by an infrared remote control as standard. This enables straightforward operation of the devices without the need to install any additional electrical component.

Connecting multiple devices by means of a bus line allows for centralised control of up to 32 devices (master/slave).

Application areas

- Office and administrative buildings
- Shops and showrooms
- Exhibition rooms
- Rooms with high thermal loads
- Reception areas and foyers
- Meeting and conference rooms

Product benefits

- Elegant solution for integration into ceilings
- Dimensions conforming to Euroraster format
- Quick and easy to install
- Quiet operation
- Device structure that is easy to maintain
- Attractive design
- Low construction height
- High thermal outputs
- Wide range of accessories available
- Ceiling panel available in all RAL colour schemes
- Master/slave function for centralised control of up to 32 devices possible

Provided as standard

- Infrared remote control
- Additional air outlet for separate grille
- Programmable 24-hour timer function
- Integrated condensate pump (up to 800 mmWS)
- Master/slave function and potential-free contact on control circuit board
- External drain pan

Exploded view emcotherm DKK (models 03 to 08)

- | | |
|--|--|
| 1. Sensor position | 10. Grille |
| 2. Fan motor | 11. Outlet louver |
| 3. Coil | 12. Swing motor |
| 4. Condensate hose | 13. Air filter |
| 5. Fan blade | (can be easily serviced via the front of the device) |
| 6. Condensate pump assembly | 14. Air inlet grille |
| 7. Condensate drain pan | (easy to open and fold down for inspection purposes) |
| 8. Air inlet (assembly) | 15. Transformer |
| 9. Finger guard grille with circulated air sensor | 16. Fan capacitor |
| | 17. Control circuit board |
| | 18. IR remote control |

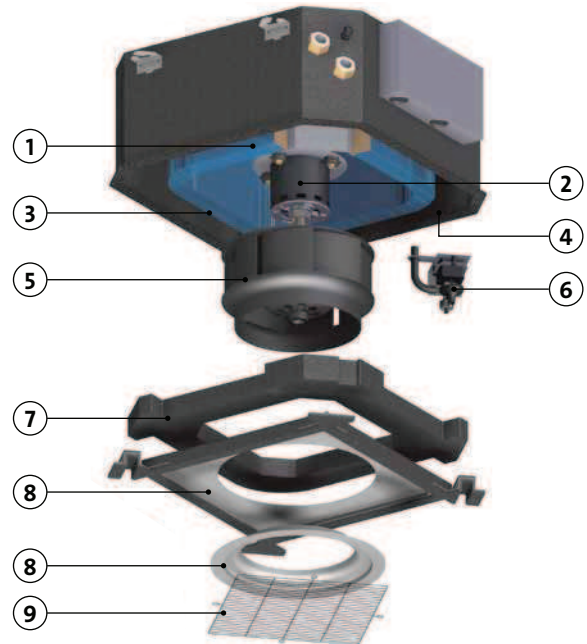

Optional accessories:

Wired remote controller (ID no. 870-4024)

Wired remote control for controlling of emcotherm DKK03-16 with display, incl. 5 m connector cable

Bus connection line (ID no. 870-4025)

Bus connection line for connecting multiple devices to an internal network (master/slave)

3-way valve assembly for DKK03 to DKK08

(ID no. 870-4026)

Valve assembly consisting of:

- 1x thermal actuator
 - 1x 3-way valve (DN 15)
 - 2x shutoff valves
 - 1x tee (DN 20)
 - 1x stainless steel corrugated pipe
- incl. screw connections and associated sealing material

3-way valve assembly for DKK09 to DKK16

(ID no. 870-4027)

Valve assembly consisting of:

- 1x thermal actuator
 - 1x 3-way valve (DN 25)
 - 2x shutoff valves
 - 1x tee (DN 25)
 - 1x stainless steel corrugated pipe
- incl. screw connections and associated sealing material

External condensate pump (ID no. 870-4023)

Additional external condensate pump.

Max. capacity: 294 l/h; max. delivery head: 4.3 m.

Dimensions: 288 x 127 x 178 mm.

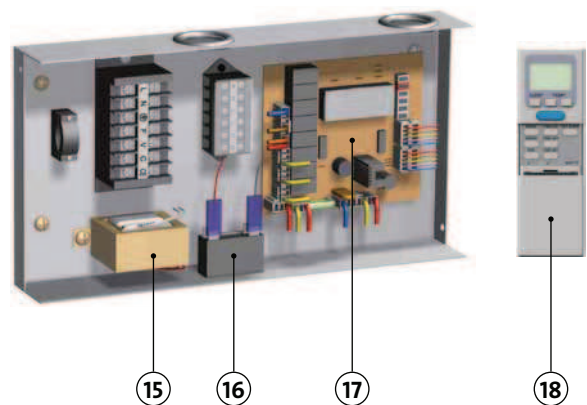
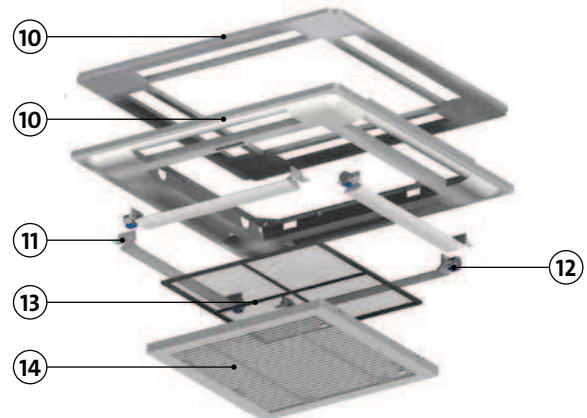

Cassette fancoils in compact Euroraster format.

Method operation

The images shown provide an example of how fancoils can be integrated into the existing water system at site (water chiller/heatpump unit and pipework are not included in the emco scope of supply).

An individual cassette unit functions as follows: The room air is extracted via the air inlet grille using a 3-speed fan motor. In the case of cooling operation, temperature exchange takes place at the integrated cooling coil. The supplied warm room air is cooled by means of the cooling coil, through which cooled water flows, and the cooled air is fed back into the room.

Where heating is concerned, the room air is warmed up to the correct set temperature. For cooling purposes, what is known as a swing function is used to enable improved air distribution in the room. A condensate drain pan and a condensate pump with a maximum capacity height of 800 mmWS are installed inside the device to deal with any condensate that is produced. An optional valve assembly can be used with the emcotherm DKK to control how it interacts with the water supply. When heating or cooling capacity is required, a 3-way valve opens the path for the medium to the heat exchanger. If no thermal functions are required at that point, the medium is led past the cassette and back to the chiller.

This ensures a minimum volume flow (see “Diagram of medium circuit”).

To improve the quality of the room air, primary air can be supplied by means of a connection option designed specifically for this purpose. In addition to this, the emcotherm cassette fancoil offers the option of supplying an adjacent room at the same time by means of a pipe system, using circulated air see fig. “emcotherm DKK – ventilation”).

System structure

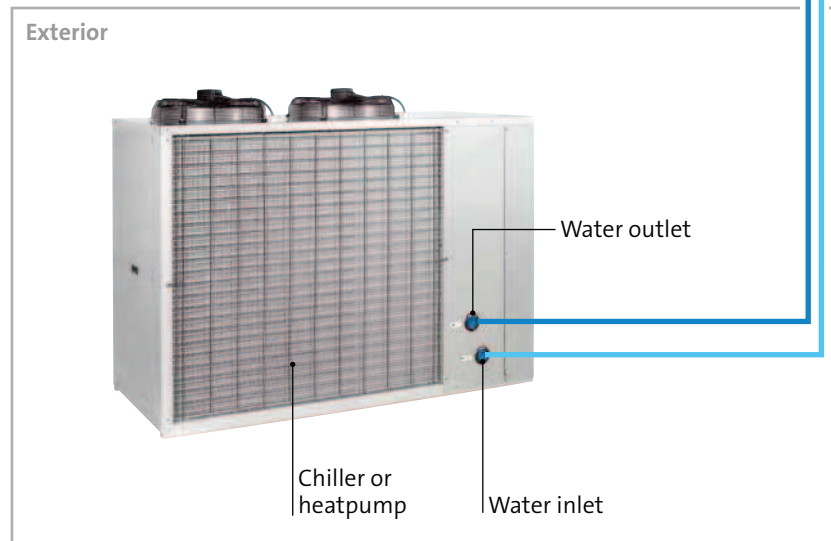
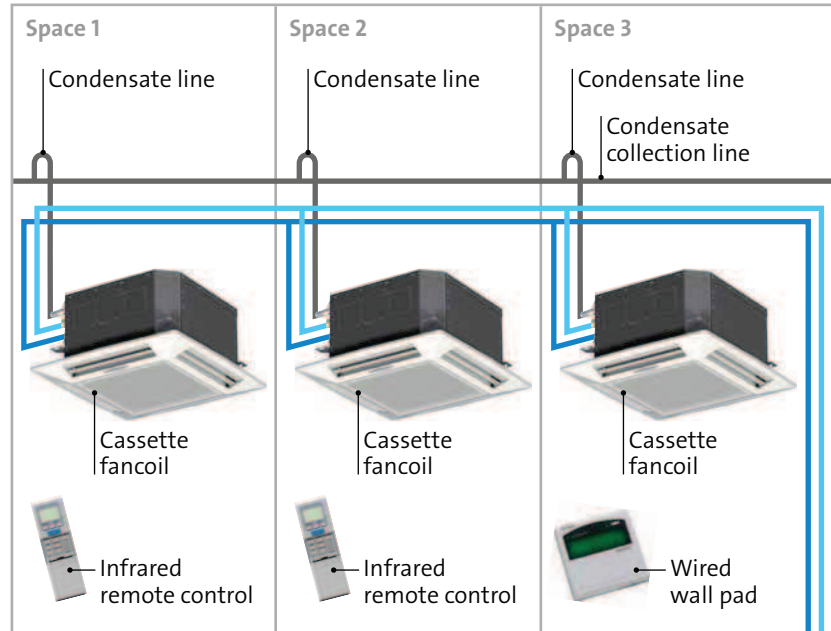
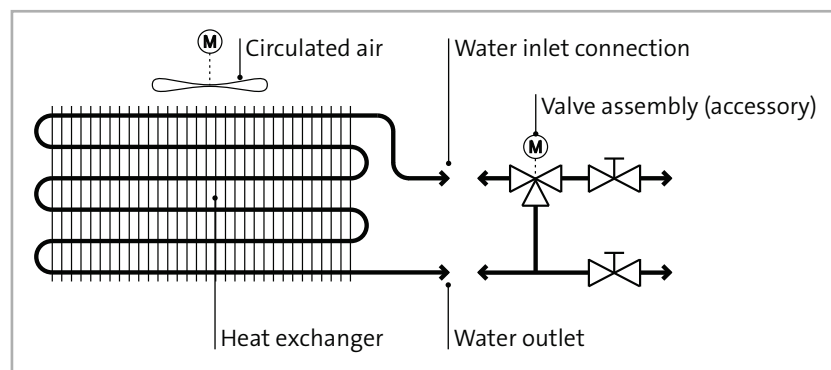



Diagram of hydraulic circuit



For heating, cooling, ventilation and dehumidifying.

emcotherm **DKK – cooling power, total (Q_k) and adjusted (Q_s)**

	Water inlet		5 °C		7 °C		9 °C		11 °C		13 °C	
	Volume flow [m³/h]	Pressure loss [kPa]	Q_k [kW]	Q_s [kW]	Q_k [kW]	Q_s [kW]	Q_k [kW]	Q_s [kW]	Q_k [kW]	Q_s [kW]	Q_k [kW]	Q_s [kW]
DKK03	0.48	7.00	2.37	1.32	2.00	1.19	1.73	1.05	1.43	0.94	1.04	0.79
DKK04	0.59	10.20	3.52	1.64	3.00	1.44	2.59	1.23	2.17	1.03	1.57	0.83
DKK06	0.77	9.60	4.86	2.26	4.00	2.01	3.63	1.76	3.07	1.53	2.28	1.17
DKK08	0.94	13.90	5.85	2.65	5.00	2.23	4.25	1.99	3.56	1.69	2.56	1.20
DKK09	1.27	22.50	7.43	3.15	6.50	2.68	5.66	2.26	4.84	1.88	3.77	1.37
DKK10	1.45	24.90	8.67	4.22	7.50	3.63	6.48	3.13	5.48	2.48	4.13	1.90
DKK12	1.50	12.30	10.36	4.93	9.00	4.12	7.64	3.44	6.42	2.75	4.68	2.14
DKK16	1.77	15.40	12.41	5.98	10.50	5.22	9.05	4.44	7.59	3.67	5.44	2.45

Air inlet temperature DB 27 °C/WB 19 °C, 0 % glycol concentration, max. air volume flow

emcotherm **DKK – heating power, total (Q_k)**

	Water inlet		40 °C	45 °C	50 °C	55 °C	60 °C	65 °C	70 °C
	Volume flow [m³/h]	Pressure loss [kPa]	Q_k [kW]	Q_k [kW]	Q_k [kW]	Q_k [kW]	Q_k [kW]	Q_k [kW]	Q_k [kW]
DKK03	0.48	4.92	1.60	2.03	2.24	2.89	3.42	3.85	4.28
DKK04	0.59	4.87	2.18	2.73	3.23	3.84	4.39	4.94	5.50
DKK06	0.77	5.62	2.79	3.50	4.20	4.91	5.62	6.33	7.04
DKK08	0.94	8.12	3.63	4.44	5.28	6.28	7.30	8.22	9.14
DKK09	1.27	20.18	4.66	5.78	7.16	7.96	8.89	9.85	10.96
DKK10	1.45	22.76	5.36	6.79	8.34	9.44	10.67	11.90	13.23
DKK12	1.50	27.47	6.51	8.48	9.90	11.61	12.78	14.06	15.63
DKK16	1.77	15.79	7.47	9.29	11.02	13.53	15.35	17.18	19.11

Air inlet temperature DB 20 °C. 0 % glycol concentration, max. air volume flow

emcotherm **DKK – ventilation**

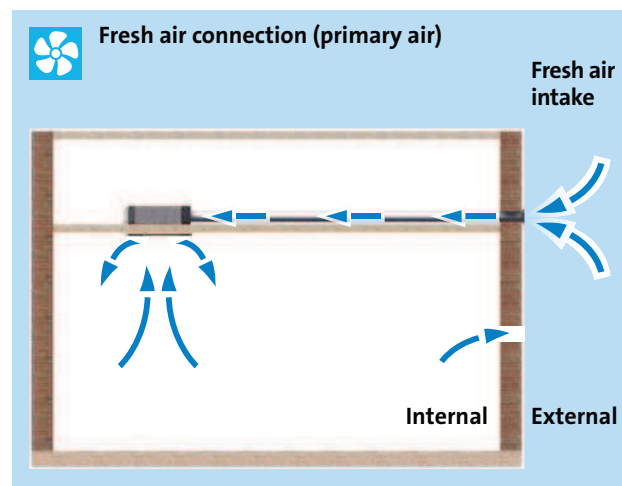
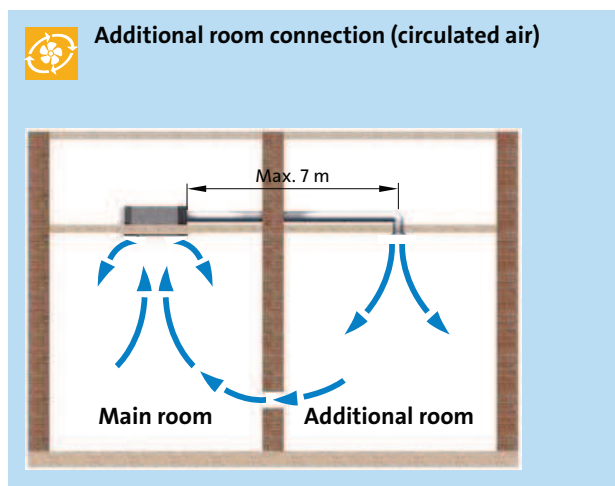

Available in 8 capacity sizes.

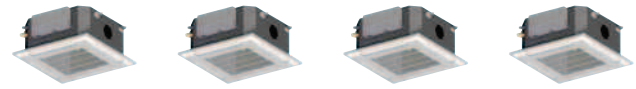

emcotherm DKK specifications

	Unit	Model DKK03	Model DKK04	Model DKK06	Model DKK08
Application area (room volume), approx.	m ³	60	100	130	160
Room temperature adjustment range	°C	+16 to +30			
Internal device working range	°C	+15 to +35			
Air volume flow acc. to stage	m ³ /h	336/396/450	348/420/510	468/564/624	516/624/768
Sound pressure level ¹⁾	dB(A)	29/35/38	30/36/39	35/41/43	37/43/46
Power supply	V/Hz	230/1~/50			
Degree of protection	IP	IP 44			
Electr. nominal power consumption ²⁾	kW	0.03	0.03	0.06	0.07
Electr. nominal current consumption ²⁾	A	0.21	0.25	0.29	0.39
Operating medium		Water ³⁾			
Operating limits, cooling medium	°C	+4 to +18			
Operating limits, heating medium	°C	+35 to +80			
Operating pressure, max. medium	kPa	1400			
Minimum flow temperature, heating	°C	+40			
Water connection, inlet	inches	3/4 (internal)			
Water connection, outlet	inches	3/4 (internal)			
Water volume	l	1.3		1.8	
Condensate connection	mm	19			
Condensate pump, max. capacity	mmWS	800			
Gross weight	kg	28.0		31.0	
Operating weight, approx.	kg	29.3		32.8	

1) Distance of 1 m 2) Air inlet temperature DB 27 °C/WB 19 °C, medium inlet 7 °C, medium outlet 12 °C, 0 % glycol concentration, max. air volume flow

3) max. 35 % ethylene glycol, max. 35 % propylene glycol

emcotherm DKK – dimensions for models 03 to 08

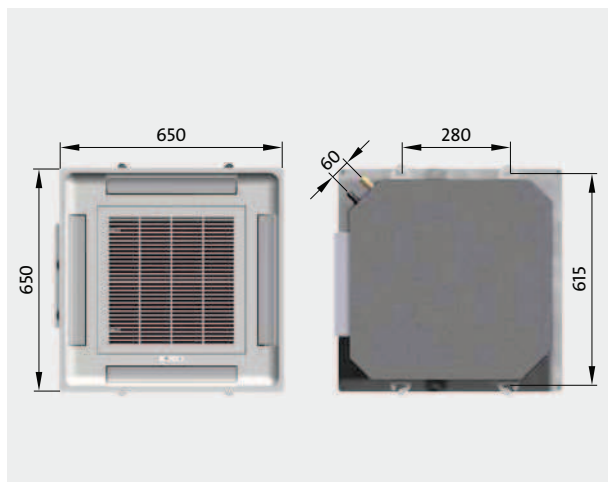

emcotherm DKK – dimensions for models 03 and 04

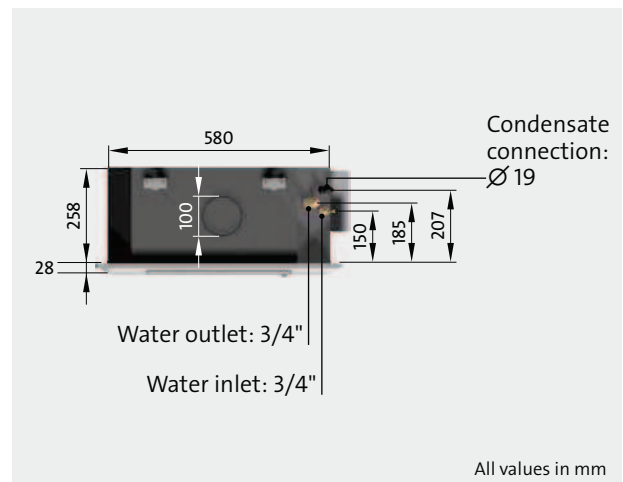

All values in mm

emcotherm **cassette fancoils** – product overview

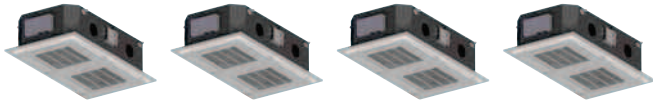

Model DKK 09	Model DKK10	Model DKK12	Model DKK16
210	250	300	350
+16 to +30			
+15 to +35			
690/840/1020	780/960/1158	930/1110/1284	1050/1260/1500
34/39/40	36/40/43	38/45/49	40/47/50
230/1~/50			
IP 44			
0.06	0.12	0.12	0.13
0.41	0.63	0.63	0.82
Water ³⁾			
+4 to +18			
+35 to +80			
1400			
+40			
3/4 (internal)			
3/4 (internal)			
1.5		2.9	
	19		
	800		
	59.0		
60.5		61.9	

emcotherm **DKK** – dimensions for models 09 to 16

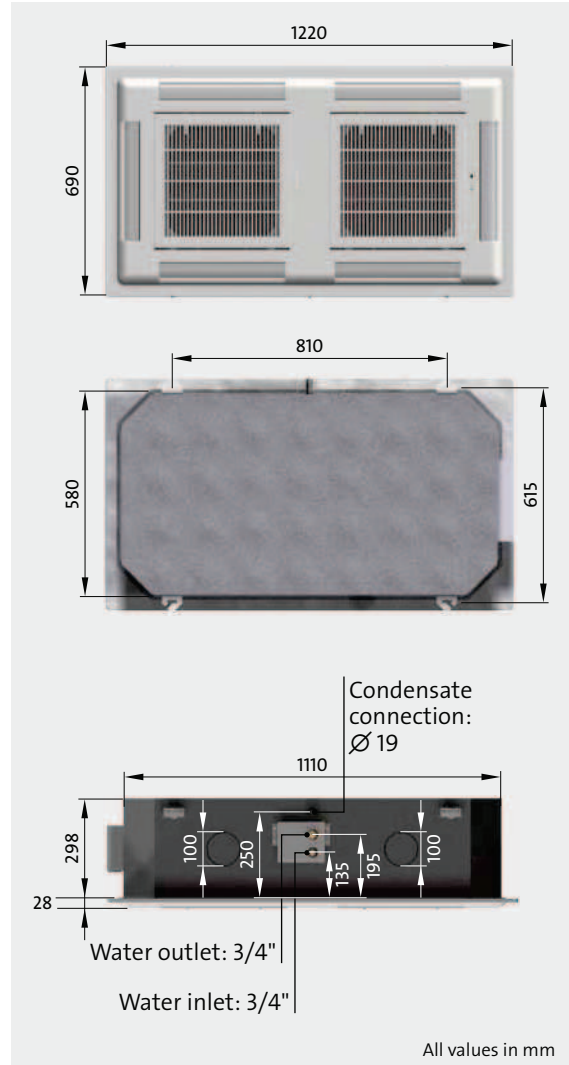

emcotherm **DKK** – dimensions for models 06 and 08

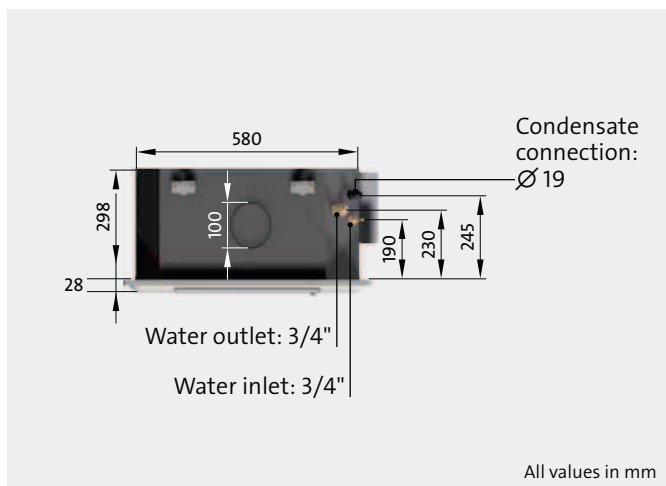

Quick selection

- DKK 03** 000 0650650 = for approx. 60 m³ room volume
- DKK 04** 000 0650650 = for approx. 100 m³ room volume
- DKK 06** 000 0650650 = for approx. 130 m³ room volume
- DKK 08** 000 0650650 = for approx. 160 m³ room volume
- DKK 09** 000 1220650 = for approx. 210 m³ room volume
- DKK 10** 000 1220650 = for approx. 250 m³ room volume
- DKK 12** 000 1220650 = for approx. 300 m³ room volume
- DKK 16** 000 1220650 = for approx. 350 m³ room volume



Infrared remote controller (standard accessory)

For cooling, heating, ventilation and dehumidifying purposes, emcotherm cassette fancoils can be controlled automatically or manually (by the enduser) using an infrared remote control which is included as standard in the scope of supply.

Additionally, it is possible to set the required room temperature, based on a timer function by the simple touch of a button.

If multiple cassette fancoils are being used in a room or building, an infrared remote control can be used for all the devices as part of an internal network. A wired remote control enables each individual ceiling panel to be addressed and programmed individually within an internal network (master/slave). The optional three-way valve assembly, or a valve assembly that has been adapted to fit the system in question, can be used to control the flow of the water supply.



Wired remote controller

As an option in addition to the infrared remote controller, the emcotherm cassette fancoil can also be controlled by means of a wired remote controller. This enables the use of all the control functions that are offered by the infrared remote control, but allows greater distances to be covered for the purpose of controlling the cassette fancoil when compared with the infrared remote control.

What is more, the wired remote control provides the option of individual programming of each device in an existing network.

Master/slave

Up to 32 devices can be operated simultaneously thanks to the parallel connection system by means of a bus line (accessory). The devices can all access this internal network in parallel. The network may consist of one master device and up to 31 slave devices.

Network with infrared remote controls

- The infrared remote control (supplied as standard) operates a master device. All of the slave devices are set in accordance with the programming configurations.
- Customised operation of each individual slave device can be carried out using the infrared remote control or the wired remote control (accessory).
- A master's device address is determined according to whether a JPO jumper is positioned on the control circuit board or device jumper is not positioned.

Network with wired remote controls (optional accessories)

- The wired remote control (available as an accessory) operates a master device. All slave devices with wired remote controls can be programmed individually and directly or as an entire group from the master device.
- Customised operation of each individual slave device can be carried out using the wired remote control.
- The master and slave devices are addressed via the wired remote control configuration settings.