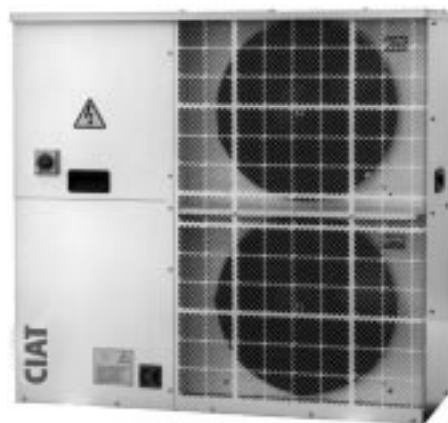

Cooling capacity : 5 to 20 kW

**PROPELLER
CONDENSER**

Compact and silent equipment
Perfectly suited to all types of
evaporators, air as well as water

Use

The **CONDENCIAT series CS** condensing units with air cooled condensers are packaged units intended for external siting.

These condensing units are suitable for small and medium size air conditioning installations : shops, offices, laboratories, restaurants, etc.

They are designed to be connected to a direct expansion exchanger type :

- Air handling box coil, type CLIMACIAT FE or GI
- Separate water cooling evaporator, type EXEL, HF, FYN or integrated to an air handling unit type CIATRONIC DDA.

For utilization with air handling units equipped with direct expansion coils, study carefully the regulation. Some regulation modes are not compatible with the direct expansion solution.

Two methods are to be prohibited :

- Variable air by-pass on the direct expansion coil
- All fresh air operation with discharge temperature control

The condensing groups are manufactured in conformity with directives :

- Machines 89/392 CEE modified
 - CEM 89/336 CEE
- in order to be integrated in a CE installation

QUICK SELECTION

CONDENCIAT CS

PROPELLER
CONDENSER

Size	Number of circuits	Number of compressors	Cooling capacity	Power consumption
20	1	1	5,34	1,91
23	1	1	6,70	2,70
30	1	1	8,38	3,47
35	1	1	10,70	3,78
50	1	1	12,70	5,33
65	1	1	16,60	6,27
75	1	1	19,00	7,50

CS selection (R22)
Evaporation temperature + 2°C
Condenser air temperature + 35°C

DESCRIPTION

The refrigerant circuit includes :

■ Reciprocating hermetic compressor

- Internal protection of motor windings
- Crankcase heater

■ Air cooled condenser

- Coil with copper tubes, aluminium fins
- Direct drive propeller fan(s)
- Rotation speed 850 rpm
- Sealed motors

■ Control and safety unit

- High and low pressure safety pressostat
- Filter dryer
- Liquid sight glass

The electrical panel is composed of :

■ Electrical switchgear and automatic control panel

- Panel conform to norm NFC 15100 and EN 6020461
- 4 pole safety switch
- Compressor contactor
- General earthing

■ Casing

- In pre-painted sheet metal

■ Refrigerant connections :

- to be brazed

OPTIONS

■ All year round operation

■ Condensing pressure control by high pressure pressostat(s)

■ Refrigerant connection sleeves

■ Supply voltage : 230 V* - 3 ph - 50 Hz + earth

* standard voltage in France

COOLING CAPACITIES

R 22	CS	Evaporating temperature in °C	INLET AIR TEMPERATURE AT THE CONDENSER °C									
			25		30		35		40		45	
			Pf kW	Pa kW	Pf kW	Pa kW	Pf kW	Pa kW	Pf kW	Pa kW	Pf kW	Pa kW
20	0	5,42	1,68	5,21	1,76	4,92	1,83	4,59	1,90	4,19	1,95	
	2	5,93	1,74	5,66	1,83	5,34	1,91	4,96	1,98	4,53	2,05	
	4	6,44	1,80	6,13	1,90	5,75	1,99	5,33	2,07	4,87	2,14	
	6	6,97	1,87	6,59	1,97	6,16	2,07	5,70	2,16	5,21	2,24	
	8	7,49	1,93	7,05	2,05	6,57	2,16	6,08	2,25	5,57	2,34	
	10	8,01	2,01	7,51	2,13	6,99	2,25	6,46	2,35	5,94	2,44	
23	0	7,24	2,35	6,76	2,48	6,27	2,59	5,78	2,69	5,30	2,78	
	2	7,74	2,44	7,22	2,58	6,70	2,70	6,19	2,81	5,69	2,90	
	4	8,23	2,54	7,69	2,68	7,14	2,81	6,61	2,92	6,08	3,02	
	6	8,75	2,64	8,18	2,79	7,60	2,92	7,03	3,04	6,47	3,15	
	8	9,27	2,74	8,66	2,89	8,05	3,03	7,45	3,16	6,86	3,28	
	10	9,80	2,84	9,16	3,00	8,51	3,15	7,87	3,29	7,23	3,42	
30	0	8,96	3,08	8,40	3,20	7,82	3,31	7,25	3,41	6,68	3,49	
	2	9,59	3,22	8,99	3,35	8,38	3,47	7,78	3,57	7,19	3,66	
	4	10,20	3,36	9,60	3,50	8,96	3,62	8,32	3,73	7,70	3,83	
	6	10,90	3,50	10,20	3,65	9,53	3,78	8,87	3,90	8,23	4,00	
	8	11,50	3,65	10,80	3,80	10,10	3,93	9,43	4,06	8,77	4,17	
	10	12,20	3,79	11,40	3,94	10,70	4,09	9,99	4,22	9,32	4,34	
35	0	11,30	3,31	10,60	3,48	9,97	3,64	9,28	3,78	8,60	3,92	
	2	12,20	3,43	11,50	3,61	10,70	3,78	10,00	3,94	9,37	4,08	
	4	13,10	3,56	12,40	3,75	11,60	3,93	10,80	4,10	10,10	4,25	
	6	14,10	3,69	13,30	3,90	12,50	4,09	11,70	4,26	11,00	4,42	
	8	15,10	3,83	14,20	4,04	13,40	4,25	12,60	4,43	11,90	4,60	
	10	16,10	3,97	15,20	4,20	14,30	4,41	13,60	4,60	12,80	4,78	
50	0	13,50	4,65	12,60	4,90	11,70	5,13	10,90	5,32	10,10	5,48	
	2	14,50	4,84	13,60	5,10	12,70	5,33	11,80	5,53	11,00	5,69	
	4	15,60	5,02	14,60	5,29	13,70	5,52	12,80	5,73	11,90	5,90	
	6	16,70	5,20	15,70	5,48	14,80	5,72	13,80	5,93	13,00	6,10	
	8	17,90	5,39	16,90	5,66	15,90	5,91	14,90	6,12	14,00	6,30	
	10	19,10	5,57	18,00	5,85	17,00	6,10	16,10	6,31	15,20	6,49	
65	0	17,50	5,52	16,40	5,77	15,30	6,01	14,30	6,23	13,20	6,43	
	2	18,90	5,75	17,70	6,02	16,60	6,27	15,50	6,51	14,40	6,72	
	4	20,30	5,99	19,10	6,28	17,90	6,54	16,70	6,79	15,50	7,01	
	6	21,80	6,24	20,50	6,54	19,20	6,82	18,00	7,08	16,70	7,32	
	8	23,30	6,50	21,90	6,82	20,60	7,11	19,30	7,39	18,00	7,63	
	10	24,80	6,77	23,40	7,10	22,00	7,41	20,60	7,70	19,30	7,96	
75	0	20,60	6,50	19,00	6,80	17,60	7,20	16,30	7,50	15,10	7,80	
	2	22,00	6,70	20,50	7,10	19,00	7,50	17,40	7,90	16,30	8,20	
	4	23,30	6,90	22,00	7,40	20,30	7,70	18,60	8,20	17,40	8,50	
	6	25,00	7,10	23,30	7,60	21,60	8,10	20,00	8,50	18,90	8,90	
	8	26,50	7,40	24,70	7,90	23,00	8,40	21,50	8,80			
	10	28,10	7,60	26,30	8,20	24,50	8,70	22,80	9,30			

PROPELLER CONDENSER

Pf : cooling capacity

Pa : power consumption

COOLING CAPACITIES

PROPELLER
CONDENSER

R 407C	CS	Evaporating temperature in °C	INLET AIR TEMPERATURE AT THE CONDENSER °C									
			25		30		35		40		45	
			Pf kW	Pa kW	Pf kW	Pa kW	Pf kW	Pa kW	Pf kW	Pa kW	Pf kW	Pa kW
20 Z	0	4.98	1.68	4.95	1.76	4.67	1.83	4.36	1.90	3.98	1.95	
	2	5.63	1.74	5.38	1.83	5.07	1.91	4.71	1.98	4.30	2.05	
	4	6.12	1.80	5.82	1.90	5.46	1.99	5.06	2.07	4.63	2.14	
	6	6.62	1.87	6.26	1.97	5.85	2.07	5.42	2.16	4.95	2.24	
	8	7.12	1.93	6.70	2.05	6.24	2.16	5.78	2.25	5.29	2.34	
	10	7.61	2.01	7.13	2.13	6.64	2.25	6.14	2.35	5.64	2.44	
23 Z	0	6.88	2.35	6.42	2.48	5.96	2.59	5.49	2.69	5.04	2.78	
	2	7.35	2.44	6.86	2.58	6.37	2.70	5.88	2.81	5.41	2.90	
	4	7.82	2.54	7.31	2.68	6.78	2.81	6.28	2.92	5.78	3.02	
	6	8.31	2.64	7.77	2.79	7.22	2.92	6.68	3.04	6.15	3.15	
	8	8.81	2.74	8.23	2.89	7.65	3.03	7.08	3.16	6.52	3.28	
	10	9.31	2.84	8.70	3.00	8.08	3.15	7.48	3.29	6.87	3.42	
30 Z	0	8.51	3.08	7.98	3.20	7.43	3.31	6.89	3.41	6.35	3.49	
	2	9.11	3.22	8.54	3.35	7.96	3.47	7.39	3.57	6.83	3.66	
	4	9.69	3.36	9.12	3.50	8.51	3.62	7.90	3.73	7.32	3.83	
	6	10.36	3.50	9.69	3.65	9.05	3.78	8.43	3.90	7.82	4.00	
	8	10.93	3.65	10.26	3.80	9.60	3.93	8.96	4.06	8.33	4.17	
	10	11.59	3.79	10.83	3.94	10.17	4.09	9.49	4.22	8.85	4.34	
35 Z	0	10.74	3.31	10.07	3.48	9.47	3.64	8.82	3.78	8.17	3.92	
	2	11.59	3.43	10.93	3.61	10.17	3.78	9.50	3.94	8.90	4.08	
	4	12.45	3.56	11.78	3.75	11.02	3.93	10.26	4.10	9.60	4.25	
	6	13.40	3.69	12.64	3.90	11.88	4.09	11.12	4.26	10.45	4.42	
	8	14.35	3.83	13.49	4.04	12.73	4.25	11.97	4.43	11.31	4.60	
	10	15.30	3.97	14.44	4.20	13.59	4.41	12.92	4.60	12.16	4.78	
50 Z	0	12.83	4.65	11.97	4.90	11.12	5.13	10.36	5.32	9.60	5.48	
	2	13.78	4.84	12.92	5.10	12.07	5.33	11.21	5.53	10.45	5.69	
	4	14.82	5.02	13.87	5.29	13.02	5.52	12.16	5.73	11.31	5.90	
	6	15.87	5.20	14.92	5.48	14.06	5.72	13.11	5.93	12.35	6.10	
	8	17.01	5.39	16.06	5.66	15.11	5.91	14.16	6.12	13.30	6.30	
	10	18.15	5.57	17.10	5.85	16.15	6.10	15.30	6.31	14.44	6.49	
65 Z	0	16.63	5.52	15.58	5.77	14.54	6.01	13.59	6.23	12.54	6.43	
	2	17.96	5.75	16.82	6.02	15.77	6.27	14.73	6.51	13.68	6.72	
	4	19.29	5.99	18.15	6.28	17.01	6.24	15.87	6.79	14.73	7.01	
	6	20.71	6.24	19.48	6.54	18.24	6.82	17.10	7.08	15.87	7.32	
	8	22.14	6.50	20.81	6.82	19.57	7.11	18.34	7.39	17.10	7.63	
	10	23.56	6.77	22.23	7.10	20.90	7.41	19.57	7.70	18.34	7.96	
75 Z	0	19.57	6.50	18.05	6.80	16.72	7.20	15.49	7.50	14.35	7.80	
	2	20.90	6.70	19.48	7.10	18.05	7.50	16.53	7.90	15.49	8.20	
	4	22.14	6.90	20.90	7.40	19.29	7.70	17.67	8.20	16.53	8.50	
	6	23.75	7.10	22.14	7.60	20.52	8.10	19.00	8.50	17.96	8.90	
	8	25.18	7.40	23.47	7.90	21.85	8.40	20.43	8.80			
	10	26.70	7.60	24.99	8.20	23.28	8.70	21.66	9.30			

Pf : cooling capacity

Pa : power consumption

TECHNICAL CHARACTERISTICS

CS		20	23	30	35	50	65	75
Compressor	Number	1						
	Type	Hermetic						
	Rotation speed	2900 tr/mn.						
	Refrigerant fluid	R 22						
Condenser	Type	Copper tubes, aluminium fins						
	Fan type	Direct drive, propeller						
	Quantity and diameter	1 / \varnothing 450		2 / \varnothing 360			2 / \varnothing 450	
	Motor power each	0,25 kW		0,18 kW			0,25 kW	
	Total air flow	2900 m ³ /h		3100 m ³ /h			5800 m ³ /h	

PROPELLER
CONDENSER

ELECTRICAL CHARACTERISTICS

CS		20	23	30	35	50	65	75	
Electrical supply	230 V - 1 ph - 50 Hz + Earth	Compressor	I. maxi A	16,1	23				
		Auxiliary circuit	I. maxi A	1	1				
		Max total intensity	A	17,1	24				
	400 V - 3 ph - 50 Hz +Earth	Compressor	I. maxi A	4,9	7,5	10	12	15	18
230 V - 1 ph - 50 Hz	Auxiliary circuit	I. maxi A	1	1	1	1,5			
	Max total intensity	A	5,9	8,5	11	13,5	16,5	19,5	23,5

ACOUSTIC CHARACTERISTICS

CS	20	23	30	35	50	65	75
Total sound level dB (A)	51	51	51	51	56	56	58

DIMENSIONS

CS 20 to 23

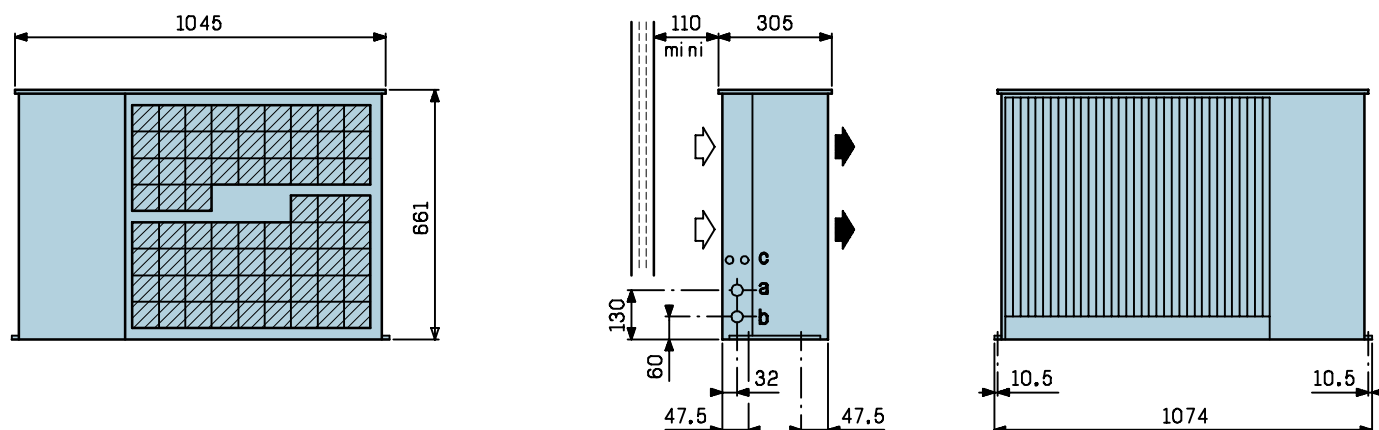

↖ Air intake

↗ Air discharge

a : Suction line connection

b : Liquid line connection

c : Electrical supply

CS	20	23
\varnothing a	5/8"	5/8"
\varnothing b	3/8"	3/8"
Mass kg	71	74

DIMENSIONS

CS 30 to 65

PROPELLER
CONDENSER

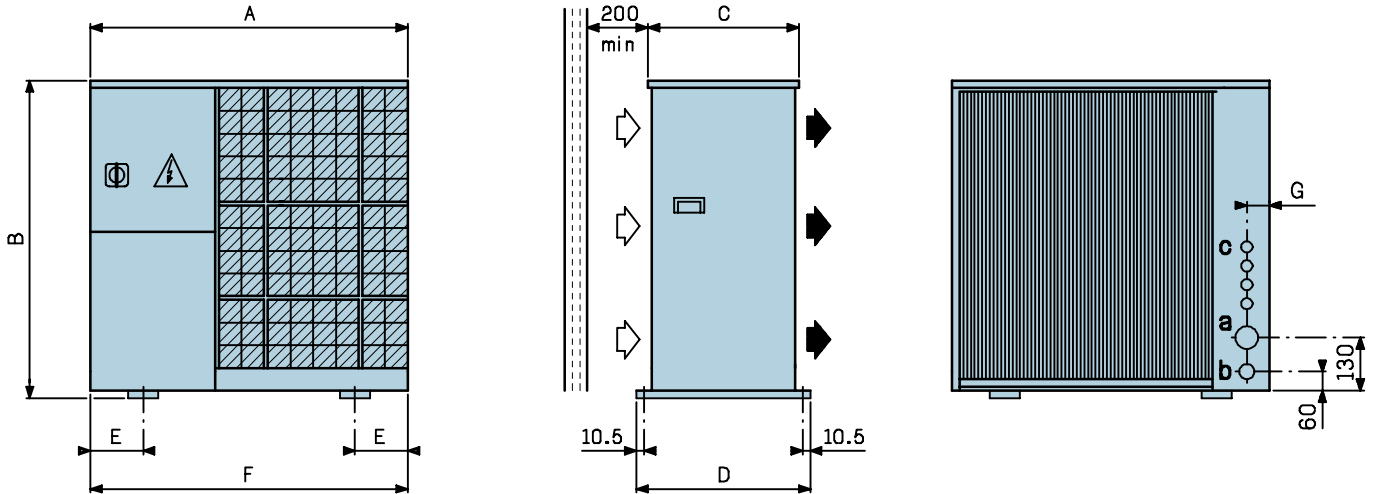

CS 75

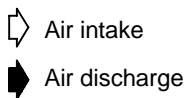
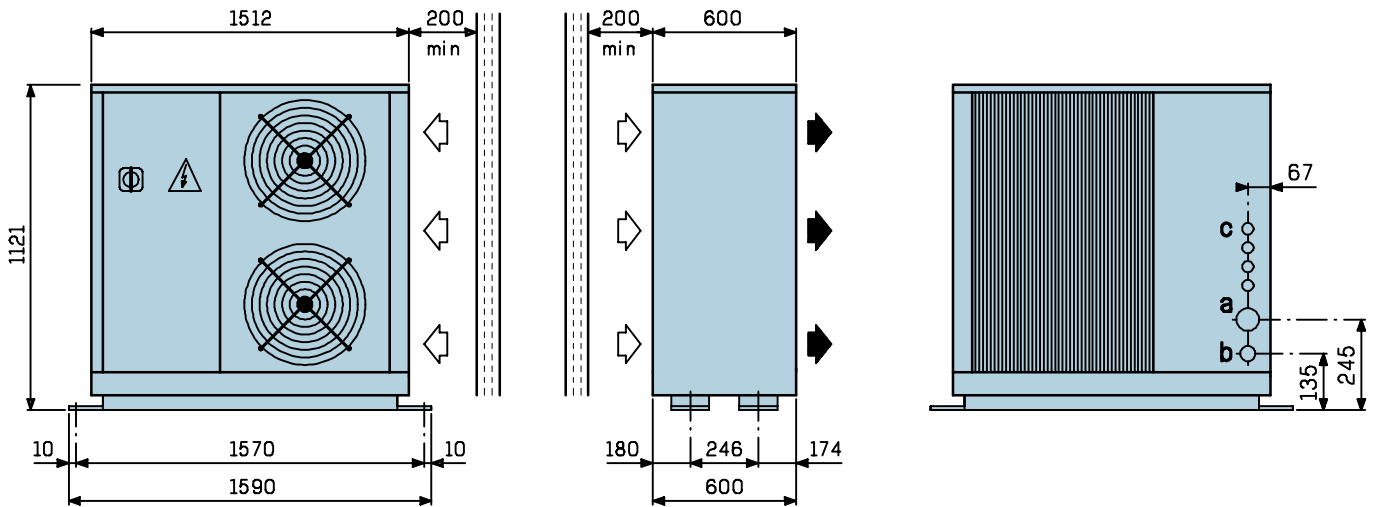

a : Suction line connection
b : Liquid line connection

c : Electrical supply

CS	30	35	50	65	75
A	924		1058		-
B	860		1010		-
C	405		485		-
D	450		530		-
E	102		165,5		-
F	924		1058		-
G	37		66		-
ø a	3/4"		7/8"		1" 1/8"
ø b	3/8"		1/2"		5/8"
Mass kg	86	114	115	120	215

RECOMMENDATIONS FOR ASSEMBLY

Siting

- The **CONDENCIAT serie CS** are designed to be positioned outside, on the ground or on the roof.
- A space must be planned all around the unit for carrying out connection, servicing and maintenance operations.
- No obstacle should block the air intake on to the coil and at the fan outlet.
- Study with care the siting of the unit select a place compatible with the environment requirements (sound level, integration on the site, etc...).

Electrical connections

All instructions necessary for electrical connections are contained in the wiring diagram supplied with the unit (compliance is essential).

These connections are to be made in accordance with good engineering practice and regulations in force for the site.

Work to be carried out on site :

- Power (230 V - 1 ph ou 400 V - 3 ph according to models selected), neutral and earth lines connection to the appropriate terminals.
- The thermostat, automatic valve, external controls are also to be connected as appropriate.

Note

The main supply must be fitted by the installer with either a fused isolator or a motor starter.

Important

When the unit is in service, the electrical panel must always be under voltage to allow constant heating of the crankcase during periods of rest, thus eliminating starting problems.

Before starting the unit the first time or following a prolonged break, the electrical panel should be switched on for several hours.

Refrigerant circuits

This work which must be carried out to the highest standards possible, consists basically of the following operations :

- The fitting of the direct expansion coil with refrigeration components (expansion valve, solenoid valve). In the case of CIAT supplied material these components are factory fitted.
- The connection of the refrigerant pipework consisting of suction, refrigerant lines between the coil and the CONDENCIAT unit.
- The careful study of the refrigerant circuit (in particular falls, restrictions and pipe diameters) to ensure the effective return of oil to the compressor.
- Ensuring that the connection are as short as possible (maximum length 15 m including 6 m of change in level). In case of doubt our technical services should be consulted.
- The insulation of suction piping.
- The evacuation of the circuit followed by the introduction of the refrigerant and the starting of the unit.

Commissioning

- Conform to our operating and maintenance instructions.

Maintenance

- Follow the instructions in our maintenance brochure.
- **Take out a maintenance contract.**

NOTES

.....

.....

.....

.....

.....

.....

.....

.....

.....

.....

.....

.....

.....

.....

.....

.....

.....

.....

.....

.....

.....

.....

.....