

Cooling capacity : 10 to 50 kW

Airflow rate : 2 000 to 12 000 m<sup>3</sup>/hNEW AIR COOLED  
CONDENSERS

**Compact size**  
and **low noise level**  
**R 22 ou R 407c**  
**automate control**  
**False ceiling or duct**  
**room discharge**

## USE

Unit specially designed to meet air treatment requirements in rooms containing computer and telecommunications equipment and rooms for specific purposes (electronics, metrology, sensitive storage, medical, controlled atmosphere rooms).

The particularly low noise level makes it suitable for use in rooms containing office equipment.

### ► Models

#### **CIATRONIC SCRIB EG**

Cabinet supplied with chilled water

#### **CIATRONIC SCRIB DDA**

Autonomous cabinet with built-in compressor and separate air condenser.

#### **CIATRONIC SCRIB DDE**

Autonomous cabinet with built-in compressor and water condenser.

For specific applications, the EG and DDA or EG and DDE models can be combined in the same unit (please consult us).

## ASSEMBLIES

► **SI assembly :**  
reverse forced air

► **SD assembly :**  
vertical forced air

Assembly 1 SI

Assembly 3 SD

Assembly 4 SD

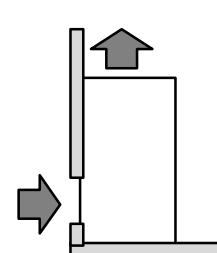
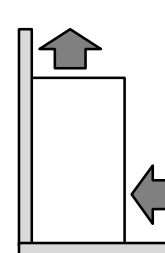
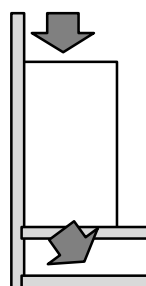

Nota : other assemblies are available, please consult us.

## RANGE

SCRIB		3 000	5 000	8 000	12 000
Air flow rate range (m <sup>3</sup> /h)	Assembly SI	2 000 to 3 000	3 000 to 5 000	5 000 to 8 000	8 000 to 10 000
	Assembly SD	2 000 to 3 000	3000 to 5 000	5 000 to 10 000	10 000 to 12 000

**SCRIB 3 000 and 5 000:** Units which can be installed in a corner of the room. Access on front panel and left or right-hand side (to be specified)

**SCRIB 8 000 and 12 000:** Units with access on front panel with technical compartment, away from the air flow, on the right-hand side.

## QUICK SELECTION

### SCRIB EG

SCRIB EG	3 000		5 000		8 000		12 000	
Air flow rate (m <sup>3</sup> /h)	2 000	3 000	4 000	5 000	8 000	10 000	10 000	12 000
Cooling capacity (kW)	9,1	13,3	17,9	22	33	41	44	49

Characteristics : water 6 °C / 11 °C, air 25 °C 50 %

Correction coefficients	21 °C 50 %		23 °C 50 %		25 °C 50 %	
<b>Chilled water mode</b>						
<b>5 °C / 10 °C</b>	0.7		0.9		1.15	
<b>6 °C / 11 °C</b>	0.6		0.75		1.0	
<b>7 °C / 12 °C</b>	0.55		0.7		0.9	
<b>8 °C / 13 °C</b>	0.5		0.6		0.8	

Correction coefficients to be applied to the cooling capacity according to the chilled water mode and return air conditions.

### SCRIB DDA - DDE

SCRIB DDA - DDE	3 000		5 000		8 000		12 000	
Air flow rate (m <sup>3</sup> /h)	2 000	3 000	4 000	5 000	8 000	10 000	10 000	12 000
Cooling capacity (kW)	8,6	12,5	16,8	20	26	32	35	40

Characteristics : water 25 °C 50 %, R 22  
SCRIB 3000, 5000 et 8000 : 1 refrigerant circuit. SCRIB 12000 : 2 refrigerant circuits

Correction coefficients	AIR INLET TEMPERATURE		
<b>Models</b>	21 °C 50 %	23 °C 50 %	25 °C 50 %
<b>DDA - DDE</b>	0.9	0.95	1.0

Correction coefficients to be applied to the cooling capacity according to the chilled water mode and return air conditions.

## DESCRIPTION

### ■ Body

- Red RAL 3020 metal frame made of galvanised sheet steel.
- Pre-enamalled RAL 7024 grey panel, double wall construction.
  - 10/10 mm prelacquered outer sheet
  - 25 mm thick class M<sub>1</sub> glass wool.
  - Internal 8 / 10 mm galvanized sheet metal

### ■ Filtration

- G4 type filtrating cells, 90 % efficiency according to ASHRAE gravimetric test.
- F7 filtration (optional).
- Filter unit with joint pointing ensuring perfect tightness
- Dirt accumulation monitored by pressure switch or air flow rate sensor.

### ■ Cooling coil

- Copper pipe coil, aluminium fins.
- Frontal speed of air < 2 m/s
- Condensates recovery try in galvanized steel with polyurethane protection.
- EG model with three-way control valve fitted.

### ■ Ventilation

- Centrifugal fan, double inlet forward curved blade impeller.
- 4-pole electric motor, IP 55, class F with OTP.
- Pulley/belt transmission,
- Fan motor unit on anti-vibration mounts and driving pulley with adjustable diameter optional.
- Pressure available: up to 250 Pa
- Air flow rate monitoring with pressostat or with sensor.

### ■ Electrical box

- Three-phase 400 V / 50 Hz power supply + Earth
- Emergency stop type main switch on front.
- Three-phase 400 / 24 V transformer with protections.
- Protection and control of the fan motor and according to the model or option of the humidifier, electric heater, compressor and air condenser motors.
- 3 possible controls :
  - CAREL μAC
  - CIAT MRSA PLC
  - SIEMENS Klimo Intégral PLC
- Monitoring of dry temperature at return
- Monitoring of humidity, at return, for supply and dehumidifying (optional).
- Water leak detection.
- Fault summary.

### ■ Accessories

- Support base for forced air in false floor.
- Intake or forced air plenum.
- Motorised register at intake.

### ■ Electric heater (Optional)

- Produced from shielded stainless steel elements.
- Operation controlled by fan.
- Upper limit safety thermostat with manual reset.
- 1 or 2 stage control or with TRIAC.

## ■ Hot water coil (optional)

- 1 or 2-stage coil, copper pipes, aluminium fins.
- Three-way control valve fitted.

## ■ Humidifier (Optional)

- Humidifier with immersed heating elements
  - Stainless steel immersed heating elements with large surface area
  - vapour cylinder in one easily removable element
  - filling and draining solenoid valves
  - electronic panel controlling operation
  - spraying nozzle or ramp depending on model
- Operation with mains water only (water conductivity 125 to 1250  $\mu$ S/cm and hardness 15 to 30 °F).

## ■ Refrigerant circuit (DDA and DDE models)

- MANEUROP hermetic compressor fitted with casing resistor.
- Refrigerant fluid: R 22 or R 407c.
- Thermostatic pressure reducing valve, drying filter, isolation and setting valves
- HP and LP safety pressostats
- Condensation pressure control pressure switch for DDA model.
- 2 or 3-way pressure sensitive valve optional (DDE)
- 1 refrigerant circuit (SCRIB 3 000, 5 000 and 8 000).
- 2 refrigerant circuits (SCRIB 12 000)

- Technical passage separate from the air flow for SCRIB 8 000 and 12 000 models.
- Hot gas by pass option for 2 refrigeration stages (SCRIB 3 000, 5 000 and 8 000) and 4 stages (SCRIB 12 000)
- Smooth ends connections for brazing (DDA).

## ■ Condenseur à air (modèle DDA)

- AIRIAL model propeller air condenser.
- Construction in grey RAL 7023 and RAL 7035 pre-enameled sheet metal.
- Vertical or horizontal position.
- Protection and control of each fan motor contained in the electrical box of the SCRIB unit.
- Impeller rotation speed : 900, 720, 680, 550, 440 or 320 rpm.
- Copper pipe condensation coil, aluminium fins.
- Polyurethane type blade coating, BLYGOLD or HERESITE optional.
- Proximity switches (optional).
- Smooth ends connections for brazing.

## ■ Water cooled condenser (DDE model)

- Bottle type (SCRIB 3 000 and 5 000), or soldered plate type (SCRIB 8 000 and 12 000) water condenser.
- 2 or 3-way pressostatic water valve optional.

## CONTROL

3 PLCs can be used to perform the control and monitoring functions of the units :

### CAREL automaton $\mu$ AC



- ◆ Temperature and hygrometry control
- ◆ Automatic reversal between units
- ◆ Hourly programming and fault memorization by clock card (optional).
- ◆ Connection possibility series RS 485 for survey system.

### CIAT MRSA PLC



- ◆ 160-character display containing the instruction manual and the operating status, faults and corrective actions. Configurable PLC.
- ◆ Two fault levels.
- ◆ Operating time counting
- ◆ RS 485 output on Jbus protocol.
- ◆ Control of several units possible with 1 single panel. Assistance and reversals control.

### SIEMENS



- ◆ NBRN panel which can display 1 to 16 cabinets
- ◆ NRU series programmable controller which can meet all specific control requirements.
- ◆ Possible management of rotation, backup and complements between units.

## ELECTRICAL CHARACTERISTICS

SCRIB	3 000	5 000	8 000	12 000
<b>AIR HANDLING FAN</b>				
Number of scrolls / number of motors	1 / 1	1 / 1	1 / 1	2 / 1
Motor power (kW)	0.55	1.5	2.2	3.0
Absorbed current (A)	1.6	3.6	5.1	7.2
<b>HUMIDIFIER (OPTION)</b>				
Adjustable steam flow rate (kg/h)	1 à 5			8 à 13
Power (kW)	4			10
Absorbed current (A)	6			15
<b>ELECTRIC HEATER (OPTION)</b>				
Power (kW)	8	10	15	24
Absorbed current (A)	20	25	22	35
<b>COMPRESSORS (*)</b>				
Number	1	1	1	2
Absorbed power (kW)	4	6.7	10	2 x 6.5
Maximum current (A)	12	23	27	2 x 23

(\*) Compressors corresponding to maximum cooling capacity in quick selection table.  
For other cooling capacities the compressor type may change. Please contact us for details.

## SOUND LEVELS

SCRIB		3 000		5 000		8 000		12 000	
Air flow rate (m <sup>3</sup> /h)		2 000	3 000	4 000	5 000	8 000	10 000	10 000	12 000
Sound level	EG	37	45	49	53	50	55	52	55
	DD	38	46	50	54	51	56	53	56

Sound levels at 2 m in a room with average reverberation, orifices connected and acoustically treated, +/- 3 dB.

## CONNECTIONS

- ▶ Pipes pass through zone shown on dimensional diagram.
- ▶ Condensate evacuation connection on 1 1/4" G male fitting
- ▶ The connection diameters given in the tables below correspond to the characteristics in the quick selection table. Consult us for other values.

SCRIB EG	3 000		5 000		8 000		12 000	
Cooling capacity (kW)	9.1	13.3	17.9	22.1	33	41	44	49
Connections	G 3/4"	G 3/4"	G 1"	G 1"	G 1"	G 1 1/4"	G 1 1/4"	G 1 1/4"
Water flow rate (m <sup>3</sup> /h)	1.6	2.3	3.1	3.8	5.7	7.1	7.6	8.4
Pressure drop (mCE)	6.1	5.9	4.8	7.0	6.6	8.5	4.9	5.9

Chilled water inlet / outlet connections - Water flow rate for DT = 5°C - Pressure drop with control valve.

SCRIB DDA	3 000		5 000		8 000		12 000		
Cooling capacity (kW)	9	12.4	16.5	20	25	32	34	38	
SCRIB	Liquid	1/2"	1/2"	1/2"	5/8"	5/8"	5/8"	2 x 1/2"	2 x 1/2"
	Outlet	3/4"	3/4"	3/4"	2 x 3/4"	2 x 3/4"	2 x 3/4"	2 x 3/4"	2 x 3/4"

Cooling connections on SCRIB unit

SCRIB DDE	3 000		5 000		8 000		12 000		
Cooling capacity (kW)	9	12.4	16.5	20	25	32	34	38	
Connections	G 3/4"	G 3/4"	G 3/4"	G 3/4"	G 1"	G 1 1/4"	G 1 1/4"	G 1 1/4"	
Water lost	m <sup>3</sup> /h	0.45	0.65	0.8	1.0	1.65	2.15	2.3	2.6
	mCE	4.0	3.0	4.5	4.0	3.6	3.0	3.0	3.5
Tower water	m <sup>3</sup> /h	1.3	1.8	2.4	2.9	4.7	6.1	6.65	7.2
	mCE	2.5	3.5	2.3	3.0	3.6	3.2	3.7	2.6

Water flow rate and water condenser pressure drop for a lost water inlet temperature of 18°C and a tower water inlet / outlet temperature difference of 6°C.

## DIMENSIONS

### SCRIB 3 000 and 5 000

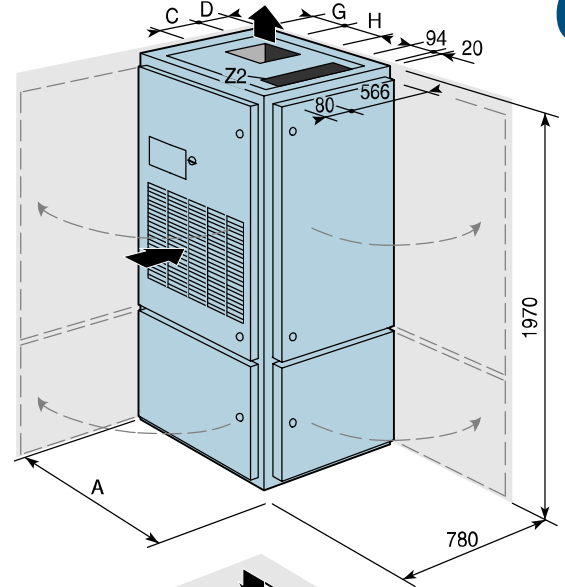
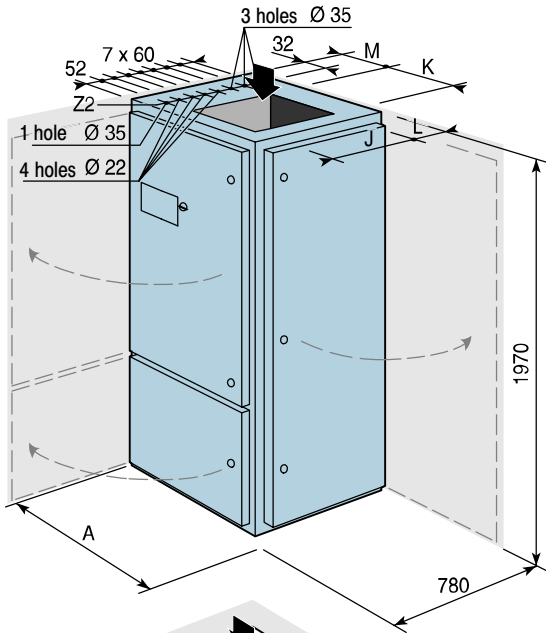

**Assembly 3 SD**

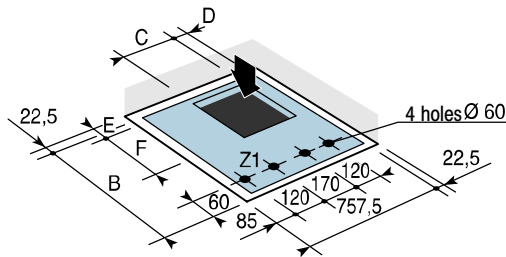

**Assembly 1 SI**

Z1 } Possible pipe passage zone  
Z2 }

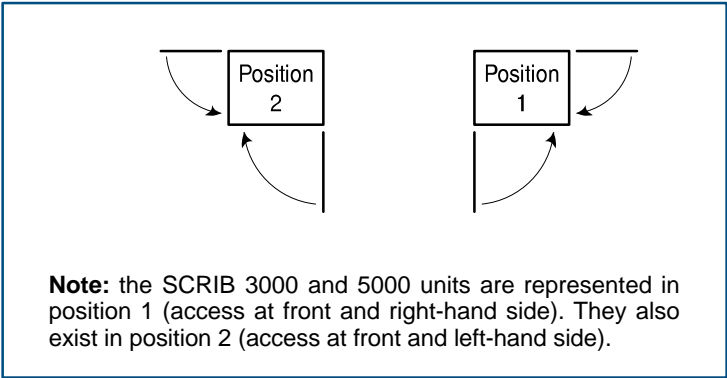

**Note:** the SCRIB 3000 and 5000 units are represented in position 1 (access at front and right-hand side). They also exist in position 2 (access at front and left-hand side).

SCRI B	A	B	C	D	E	F	G	H	I	J	K	L	M	N	Mass kg
<b>3000</b>	850	800	341	117,5	187,5	309	187,5	309	341	117,5	576	576	99,5	159,5	230
<b>5000</b>	1000	955	309	190	120	341	190	309	341	120	576	730	102	145	290

## DIMENSIONS

**SCRIB 8 000 and 12 000**  
Chilled water connection

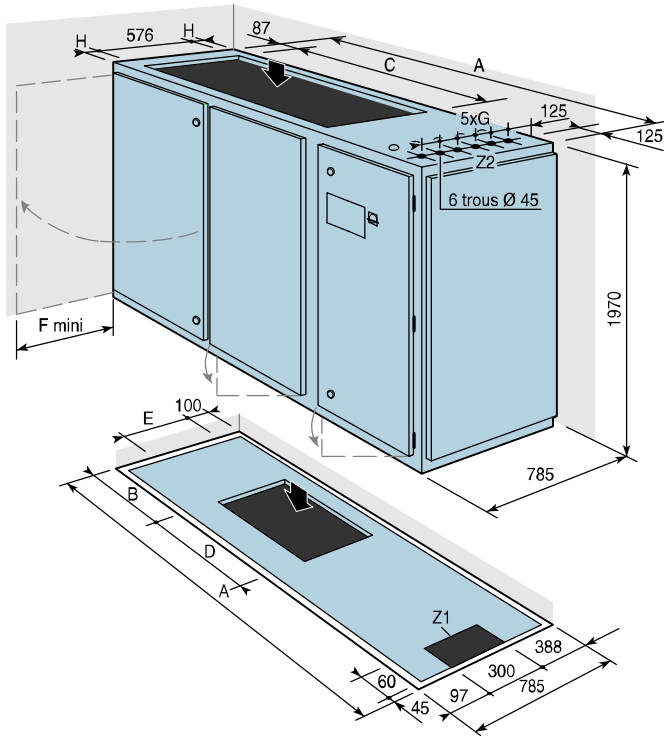

**SCRIB 8 000**  
Refrigerant connection

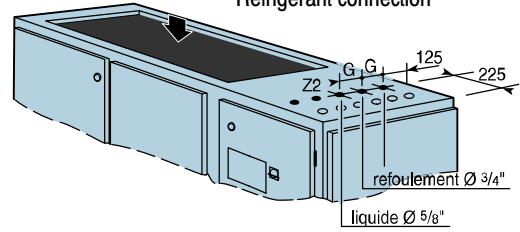

**Montage 1 SI**

**SCRIB 12 000**  
Refrigerant connection

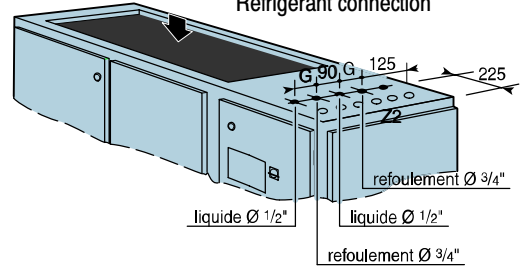

**SCRIB 8 000**  
Refrigerant connection

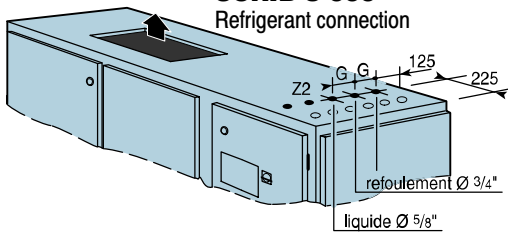

**Montage 3 SD**

**SCRIB 12 000**  
Refrigerant connection

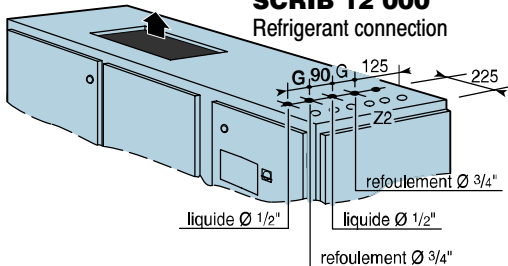

**SCRIB 8 000 and 12 000**  
Chilled water connection

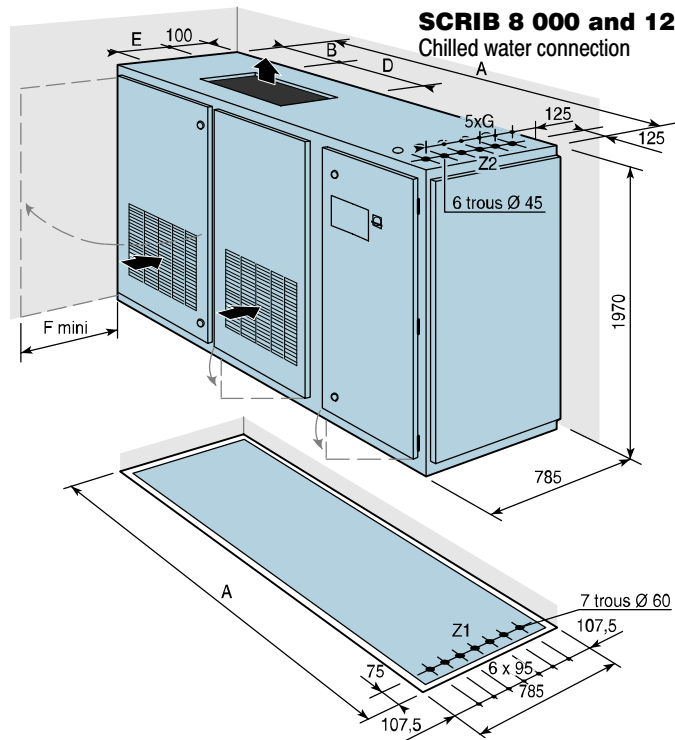

Z1 } Possible pipe passage zone  
Z2 }

SCRI B	A	B	C	D	E	F	G	H	Mass kg
<b>3000</b>	1955	410	1204	474	406	700	67,5	104,5	500
<b>5000</b>	2270	310	1522	1117	343	900	67,5	104,5	600

## AIRIAL DRYCOOLER (FOR SCRIB DDA)

### DESCRIPTION (EXAMPLE)

### AIRIAL C7023 HI 320 RESIDENTIAL

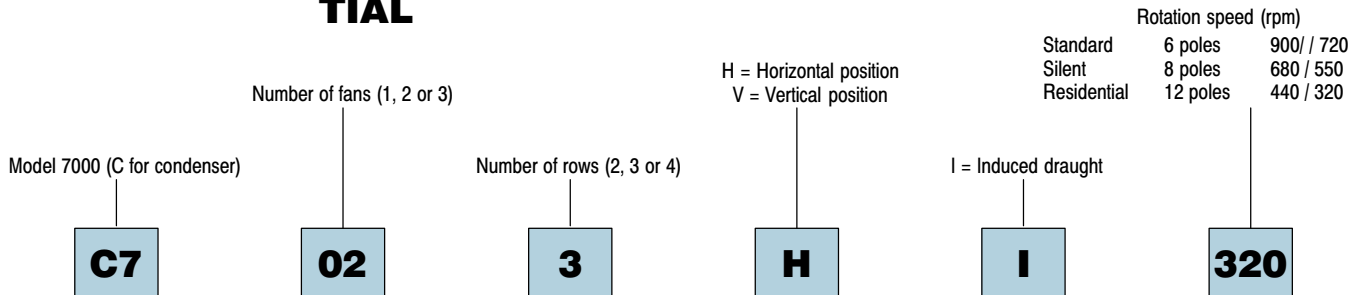

### QUICK SELECTION

Cooling capacity (kW)	Rotation speed (rpm)	OUTSIDE AIR TEMPERATURE °C					
		30		35		40	
		R 22	R 407c	R 22	R 407c	R 22	R 407c
10	900	C 7012	C 7012	C 7012	C 7012	C 7012	C 7012
	680	C 7012	C 7012	C 7012	C 7012	C 7012	C 7012
	440	C 7012	C 7012	C 7012	C 7012	C 7013	C 7013
15	900	C 7012	C 7012	C 7012	C 7013	C 7013	C 7014
	680	C 7012	C 7012	C 7012	C 7013	C 7014	C 7022
	440	C 7012	C 7012	C 7013	C 7022	C 7022	C 7023
20	900	C 7012	C 7012	C 7012	C 7014	C 7022	C 7022
	680	C 7012	C 7013	C 7013	C 7022	C 7022	C 7023
	440	C 7013	C 7022	C 7022	C 7022	C 7023	C 7032
25	900	C 7012	C 7013	C 7013	C 7022	C 7022	C 7023
	680	C 7013	C 7014	C 7022	C 7023	C 7024	C 7032
	440	C 7022	C 7022	C 7022	C 7024	C 7032	C 7034
30	900	C 7013	C 7014	C 7022	C 7023	C 7024	C 7032
	680	C 7022	C 7022	C 7022	C 7024	C 7032	C 7033
	440	C 7022	C 7022	C 7023	C 7033	C 7034	2 x C 7022
35	900	C 7014	C 7022	C 7022	C 7024	C 7024	C 7032
	680	C 7022	C 7022	C 7022	C 7033	C 7033	C 7034
	440	C 7022	C 7023	C 7032	C 7034	2 x C 7023	2 x C 7032
40	900	C 7022	C 7022	C 7022	C 7024	C 7033	C 7034
	680	C 7022	C 7023	C 7024	C 7033	C 7033	C 7034
	440	C 7023	C 7032	C 7033	2 x C 7022	2 x C 7023	2 x C 7032
45	900	C 7022	C 7022	C 7023	C 7024	C 7024	C 7033
	680	C 7022	C 7024	C 7024	C 7033	C 7034	2 x C 7024
	440	C 7032	C 7032	C 7033	2 x C 7023	2 x C 7032	2 x C 7034
50	900	C 7022	C 7023	C 7024	C 7033	C 7034	2 x C 7024
	680	C 7023	C 7024	C 7032	C 7034	2 x C 7024	2 x C 7033
	440	C 7032	C 7033	2 x C 7022	2 x C 7024	2 x C 7032	2 x C 7034

## CHARACTERISTICS

 Rotation speed (rpm)	Acoustic power levels * (Acoustic pressure levels **) dB(A)			Electrical characteristics per motor (1)		
				Power W	Intensity A	Start-up current A
900	86 (53)	89 (56)	91 (58)	1200	2,5	10
720	80 (47)	83 (50)	85 (52)	800	1,4	2,8
680	78 (45)	81 (48)	83 (50)	700	1,6	4,5
550	73 (40)	76 (43)	78 (45)	470	0,9	1,5
440	67 (34)	70 (37)	72 (39)	260	0,6	1,5
320	58 (25)	61 (28)	63 (30)	180	0,4	0,5

(\*) Only the acoustic power is characteristic of the unit. The difference between the acoustic power and the acoustic pressure level depends on the site. The values in this table have been obtained in accordance with the ISO 3744 standard.

(\*\*) Values measured at 10 m for horizontal units, in free field, directivity 2, in the same plane as the coil. Tolerance  $\pm 3$ dB.

The installation's sound pressure levels can be recalculated based on the unit's acoustic power level and the characteristics of the site (advice from an acoustic engineering consultant may be needed).

As the sound emitted is not uniform in all directions, for a point at a distance of 10 m in line with the fans, approx. 4 dB should be added to the recalculated pressure value.

(1) For three-phase 400 V, 50 Hz.

## DIMENSIONS

### Horizontal units

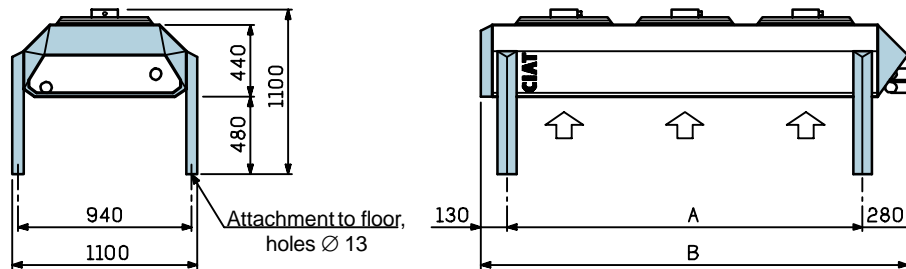

### Vertical units

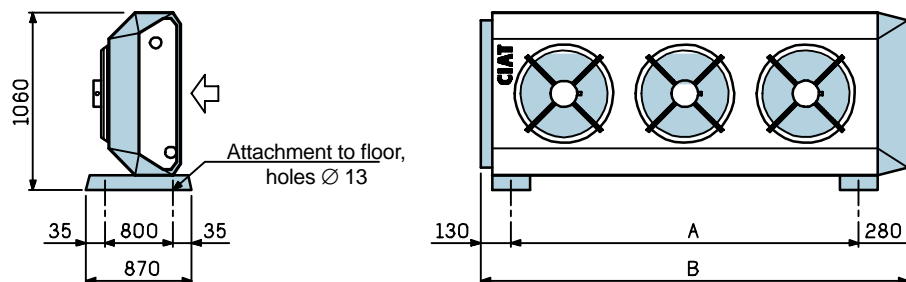

	7012	7013	7014	7022	7023	7024	7032	7033	7034
Max. content (dm <sup>3</sup> )	12	16	20	19	30	38	27	41	52
Max. empty weight (kg)	105	115	125	170	190	210	240	275	300
A (mm)	1075			2280			3485		
B (mm)	1485			2690			3895		