

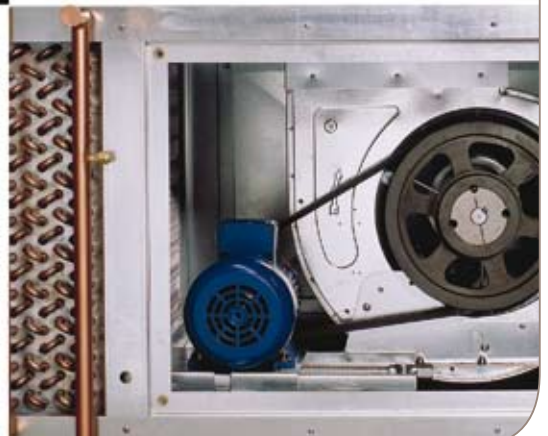

# Product manual air heat exchangers

## Refrigeration and HVAC Cooling

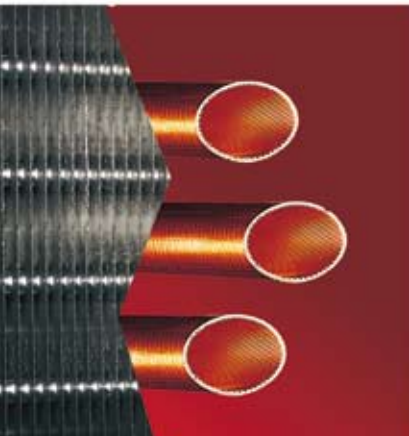

# Air Heat Exchangers Product Manual

<b>UNIT COOLER</b> .....	<b>2</b>
<b>CUBIC LINE / SINGLE AIR DISCHARGE</b> .....	<b>2</b>
General Content .....	2
Compact/Slim .....	3
AlfaCubic .....	11
Cubic Plastic .....	27
AirMax II .....	35
<b>CEILING / DUAL DISCHARGE</b> .....	<b>76</b>
General Content .....	76
Top .....	77
BFG/BFB,TFG .....	86
BigTop .....	98
<b>BLAST FREEZERS</b> .....	<b>109</b>
General Content .....	109
AlfaBlast .....	110
<b>CENTRIFUGAL UNITS</b> .....	<b>128</b>
General Content .....	128
ISC .....	129
<b>CONDENSER</b> .....	<b>136</b>
<b>ALFABLUE</b> .....	<b>136</b>
General Content .....	136
AlfaBlue Condensers - Single Fan Row .....	137
AlfaBlue Condensers - Double Fan Row .....	171
<b>ALFAGREEN</b> .....	<b>199</b>
General Content .....	199
AC - Single Fan Row .....	200
<b>ALFA V- ACV</b> .....	<b>214</b>
General Content .....	214
Alfa V- ACV .....	215
<b>CENTRIFUGAL UNITS</b> .....	<b>232</b>
General Content .....	232
CRC/CRI .....	234
<b>DRY COOLER</b> .....	<b>241</b>
<b>ALFABLUE</b> .....	<b>241</b>
General Content .....	241
BDM - Single Fan Row .....	242
BDD/BDD6 - Double Fan Row .....	267
<b>ALFAGREEN</b> .....	<b>291</b>
General Content .....	291
DC - Single Fan Row .....	292
<b>ALFA V - VDD/VDD6</b> .....	<b>301</b>
General Content .....	301
Alfa V- VDD/VDD6 .....	302
<b>MISCELLANEOUS</b> .....	<b>325</b>
<b>MISCELLANEOUS</b> .....	<b>325</b>
Miscellaneous .....	325

# Cubic Line/Single Air Discharge

## General Contents

### General Features

Most of our unit coolers are available in the following versions:

- Direct expansion evaporators
- Brine unit coolers
- Pump ammonia evaporators

### Certifications and reliability

All DX unit coolers are guaranteed by Eurovent "Certify All". Alfa Laval quality systems fully comply with ISO 9001, and all of our products are manufactured in strict accordance with CE regulations.

### Fin spacing

In our experience, fin spacing should correspond to both the goods stored and the room's air temperature, as follows:

Series	Green Line	Red Line	Blue Line
Product	Fruit / Vegetables	Meat / Fish	Frozen food
Room temperature	10 ÷ 0°C	0 ÷ -7°C	-18 ÷ -25°C
Fin spacing	3 ÷ 4,5mm	5 ÷ 6mm	≥ 7-12°mm

### Capacity

The standard conditions are in accordance with EN 328. The cooling capacities stated in the catalogue are the nominal capacities for Qn (wet conditions), in compliance with Eurovent regulations. In standard Qst conditions (dry), the nominal capacities are calculated with the following formula:

$$Q_n = Q_{st} \times \text{Wet Coil Factor}$$

Standard conditions	Air Inlet Temp °C	Evaporation Temp.(dew point) °C	R.H.	Wet Coil Factor
SC1	10	0	85%	1,35
SC2	0	-8	85%	1,15
SC3	-18	-25	95%	1,05
SC4	-25	-31	95%	1,01

The nominal capacities are calculated with refrigerant R404A. For different refrigerants the following factors should be applied:

Refrigerant	SC1	SC2	SC3	SC4
R134a	0,93	0,91	0,85	-
R22	0,95	0,05	0,95	0,95
R507	0,97	0,97	0,95	0,95
R404A	1	1	1	1

See the fin material factors below:

Fin material	Factor
Aluminium	1
Coated Aluminium	0,97
Copper	1,03

### Relative humidityΔT

The cold room hygrometric conditions are defined by the room temperature and the workingΔT. At positive cold room temperatures ΔT has an influence on the relative humidity (RH).

### Air throw

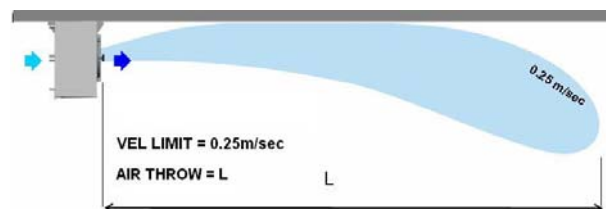

The values given in the tables are based on an air temperature of 20°C beneath a flat ceiling with no obstructions. The height and air circulation of the room can influence the air throw. The stated distances are based on a final air velocity of 0.25m/s.

### Data Sound

Lp(A) is the A-weighted sound pressure level in a room with an absorption area of 100 m<sup>2</sup> (Sabine), with the observation point at a distance of 5 m and 45° horizontally below the middle point of the fans. Lw(A) is the A-weighted sound power level measured according to EN13487; annex C.

m	1	2	3	4	5
dB (A)	6	4	2	1	0

### Defrost

All our coolers come equipped with several different defrosting systems. For room temperatures where ice build-up is likely, and where the ambient room temperature is below 0°C, a unit with a defrosting system is needed

### Test and cleaning

The coils are cleaned and dehydrated in order to remove any traces of oil. Each heat exchanger undergoes a pressure and leak test with dry air at 30 bar, before being supplied with a nitrogen pre-charge.



**Guarantee**

All our products are protected under warranty for 18 months from the shipping date. In the unlikely event of a defect occurring within the warranty period, please return the equipment or faulty part free of charge to us, where we will decide whether to repair or replace the goods. Unfortunately, We cannot take responsibility for damage caused by the misuse or incorrect installation of our products. Brochure subject to technical changes without prior notice

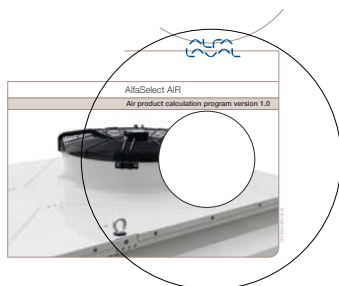

We recommend that you use the Alfa Select software for an exact thermal and mechanical design.





# Compact/Slim

## Product description

### Applications

#### Compact

The COMPACT unit is specifically designed for use in small cold rooms at positive and negative temperature with volumes ranging from 2 - 20m<sup>3</sup>. Unit designed for quick and simple maintenance with easy access to key inspection areas. This series is available as a DX evaporator.

#### Slim

The SLIM unit is specifically designed for use in small cold rooms at positive and negative temperature with volumes ranging from 4 to 70m<sup>3</sup>. Unit designed for quick and simple maintenance with easy access to key inspection areas. This series is available as a DX evaporator.

### Standard design

#### Compact Coil

- Coil manufactured from corrugated aluminium fins and copper tubes with a nominal diameter of 10mm.
- Standard fin spacing: 4.2mm
- Frame manufactured from aluminium sheets.

#### Slim Coil

- Coil manufactured from corrugated aluminium fins and copper tubes with a nominal diameter of 10mm.
- Standard fin spacing: 3mm for Slim Green Line and 4 or 8mm (progressive fin spacing) for Slim Blue Line.
- Frame manufactured from aluminium sheets.

#### Compact Casing

It is manufactured from anti-shock plastic, and is suitable for applications where a high level of hygiene is required.

#### Slim Casing

It is manufactured from anti-shock plastic, and is suitable for applications where a high level of hygiene is required. Innovative drip tray with hinges for easier opening.

### Benefits

#### Compact

- Easy handling and maintenance
- Low power consumption
- Compact design
- Eurovent certified

#### Slim

- Easy handling and maintenance
- Low power consumption
- Low noise level
- Compact design
- Eurovent certified



Compact Slim

### Options

- Drain-pipe flexible electrical heater
- Cataphoresis coil treatment
- Electric defrost

### Fans

- The SLIM/COMPACT fans come pre-wired to the connection box as standard.
- Single-phase motor 230V-50Hz, 4-pole, protection class IP44 in compliance with DIN 40050.
- Integrated thermal protection by thermal contacts.
- Reliable protection against overload.

The fans are suitable for operation in air temp. application between -40°C and +40°C.

For air temperature lower than +20°C, the full load current (FLC) can be calculated by using the correction factor table. The overload protectors should have a 20% margin to accommodate fan motor supplier variations.

T [°C]	20	10	0	-10	-15	-20	-25	-30
Fc	1	1,04	1,08	1,12	1,14	1,16	1,18	1,2

Model	Capacity SC2	Capacity SC3	Airflow	Air throw	Surface	Tube volume	Defrost	Fan motors	Power Consumption	Current Consumption	Noise	Connections	
	kW	kW	m <sup>3</sup> /h	m	m <sup>2</sup>	dm <sup>3</sup>	W	n° Ømm	W	A	dB(A) (5m)	mm	
							E**					Inlet	Outlet
<b>COMPACT</b>													
CGL1	0,5	0,41	490	6	1,7	0,65	250	1x230	42	0,21	48	10	10
CGL2	0,62	0,5	440	5,5	2,3	0,87	250	1x230	42	0,21	48	10	10
CGL3	1,07	0,85	980	6	3,4	1,2	500	2x230	84	0,42	51	1/2"SAE	16
CGL4	1,24	1,01	880	5,5	4,6	1,6	500	2x230	84	0,42	51	1/2"SAE	16
CGL5	1,34	1,09	790	5	5,7	2	500	2x230	84	0,42	51	1/2"SAE	16
CGL6	1,51	1,22	710	4,5	6,8	2,4	500	2x230	84	0,42	51	1/2"SAE	16
<b>SLIM</b>													
SGL11	1,03	0,81	900	7	5,8	1,3	550	1x300	105	0,75	46	1/2"SAE	12
SGL12	1,2	0,99	850	7	7,7	1,8	780	1x300	105	0,75	46	1/2"SAE	12
SGL13	1,75	1,42	1500	9	8,5	1,9	800	2x300	210	1,5	49	1/2"SAE	12
SGL14	2,01	1,66	1400	9	11,4	2,5	1130	2x300	210	1,5	49	1/2"SAE	22
SGL15	2,57	2,1	2200	11	12,8	2,7	1190	3x300	315	2,25	51	1/2"SAE	22
SGL16	3,07	2,45	2100	11	17	3,7	1650	3x300	315	2,25	51	1/2"SAE	22
SBL21	0,74	0,6	1050	7,5	3,7	1,3	550	1x300	105	0,75	46	1/2"SAE	12
SBL22	0,95	0,79	1000	7,5	5,2	1,8	780	1x300	105	0,75	46	1/2"SAE	12
SBL23	1,25	1,03	1751	9,5	5,5	1,9	800	2x300	210	1,5	49	1/2"SAE	12
SBL24	1,42	1,18	1649	9,5	7,6	2,5	1130	2x300	210	1,5	49	1/2"SAE	22
SBL25	1,71	1,41	2500	11,5	8,2	2,7	1190	3x300	315	2,25	51	1/2"SAE	22
SBL26	2,23	1,82	2401	11,5	11,4	3,7	1650	3x300	315	2,25	51	1/2"SAE	22

Nominal capacity according to ENV328 and Eurovent regulations ( $\Delta T_1 = T_{inair} - T_{ev}$ ). SC2:  $\Delta T=8k$  and  $T_{ev} = -8^{\circ}C$ . SC3:  $\Delta T=7k$  and  $T_{ev} = -25^{\circ}C$ .

\*\* Defrost: E = Electric heaters in the coil. Optional electric heater RS = 70W in drain-pipe.

For models CGL4, SGL12 and SBL22 an expansion valve with an external equalizer is essential.

# Compact/Slim

## Drawings

Model	Dimension mm		Weight Kg
	A	B	
<b>COMPACT</b>			
CGL1	580	455	5,5
CGL2	580	455	6
CGL3	1020	1020	10,5
CGL4	1020	1020	11
CGL5	1020	1020	11,5
CGL6	1020	1020	12
<b>SLIM</b>			
SGL11	800	570	12
SGL12	800	570	13,5
SGL13	1080	850	19
SGL14	1080	850	21
SGL15	1520	1290	29
SGL16	1520	1290	31,5
SBL21	800	570	10,5
SBL22	800	570	12
SBL23	1080	850	17
SBL24	1080	850	18,5
SBL25	1520	1290	26
SBL26	1520	1290	28

We reserve the right to change our technical data without prior notice.

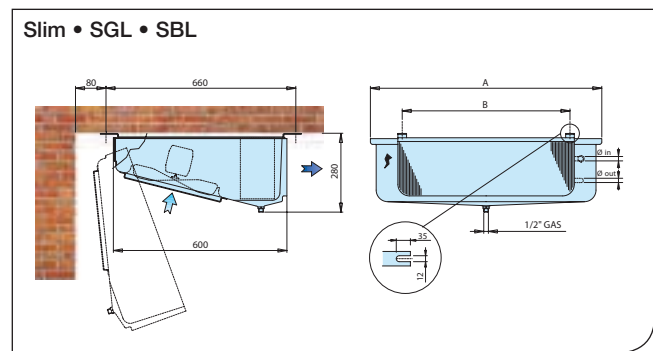
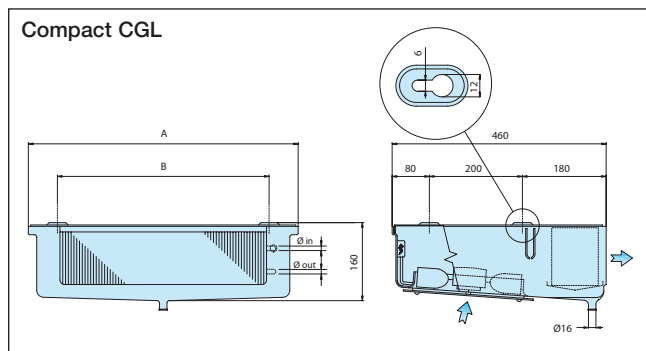

# Compact/Slim

## Options

### Cataphoresis Coil Treatment

An electrolytic process is achieved by submerging the coil in a paint bath, where it acts as a cathode and gets completely coated in an epoxy paint, which gives exceptional protection against corrosion. Recommended for alkaline or salty atmospheres.  
 Application Use: More information on corrosion prevention can be found in the Miscellaneous section.

**Model:**  
All Models

### Cable electric heater

We recommend that you heat the drain pipeline while defrosting to prevent ice forming in the pipes. The flexible electric heater can easily be placed inside the pipe.  
 Power: 70W.  
 Voltage: 230V

**Model:**  
All Models

# Compact/Slim

## Electrical Data

Junction box for motors

Series CGL/SGL/SBL

### Function

Junction box complete with screw-on cover, cable glands and terminal strip. Included as standard.

### General data

Material: Plastic

IP Protection Class: Min IP55

Colour: Grey RAL7035

Insulation class: II

Ambient Temp.: -25°C Max +50°C

Weight: 0,5 kg

### Dimensions

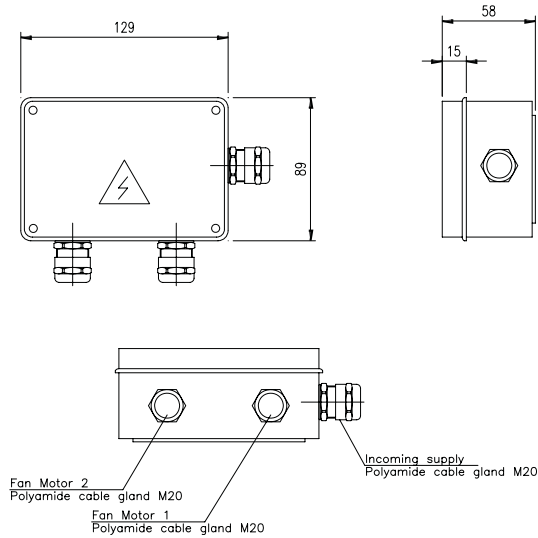

### Electric wiring diagram

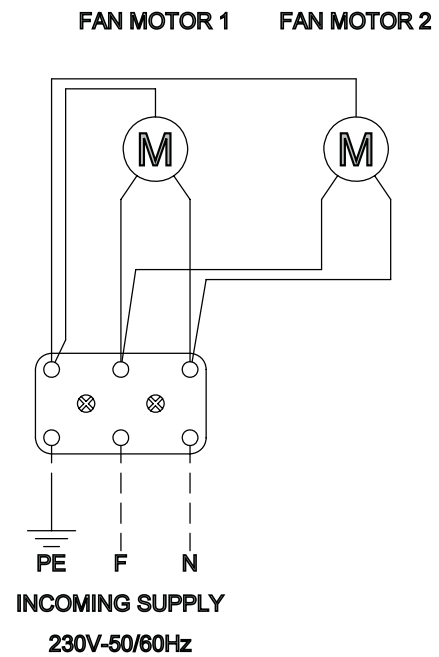



# Compact/Slim

## Electric Heater

### ALL SERIES

#### Function

The elements are designed to operate in a refrigeration field with high moisture rate.  
Special care is taken in selecting the power supply, cables and insulation materials.

#### General data

Electric Heater	Model					
	COMPACT					
	CGL1	GCL2	CGL3	CGL4	CGL5	CGL6
N°	1	1	1	1	1	1
W	250	250	500	500	500	500
	SLIM					
	SGL11	SGL12	SGL13	SGL14	SGL15	SGL16
	SBL21	SBL22	SBL23	SBL24	SBL25	SBL26
N°	1	1	1	1	1	1
W	550	780	800	1130	1190	1650

We reserve the right to change our technical data without prior notice.

# Compact/Slim

## Code description

**COMPACT**

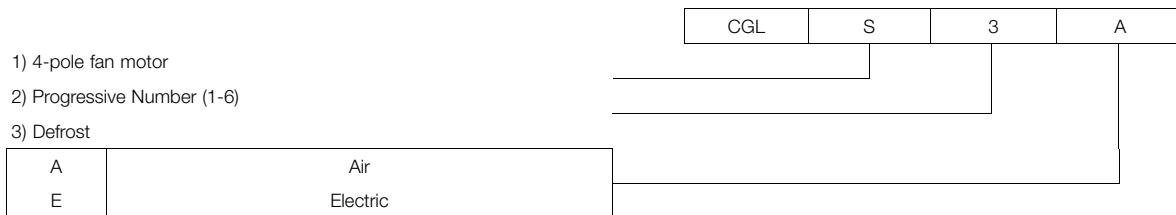

**SLIM**

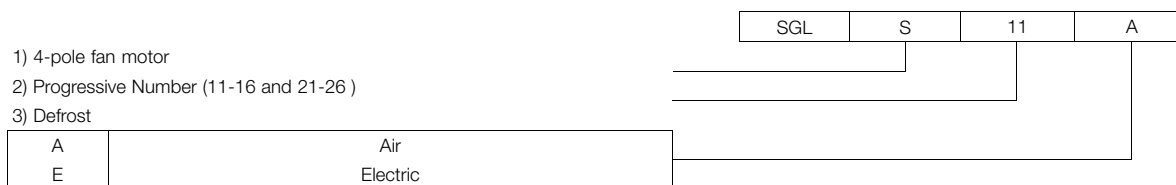

**General Alfa Select Air Legend**

Description 1		Description 2	
<b>D</b>	D fan cabling (three phase)	<b>AL</b>	Aluminium fin
<b>Y</b>	Y fan cabling (three phase)	<b>CU</b>	Copper fin
<b>D/Y</b>	D/Y fan cabling (three phase), single speed fan motor	<b>PR</b>	Pre-coated fin
<b>S</b>	Single phase	<b>SS</b>	Stainless steel tube
<b>P</b>	Packaged on a pallet	<b>TH</b>	Thermoguard treatment
<b>CR</b>	Packaged in a crate	<b>CF</b>	Cataphoresis treatment
<b>BO</b>	Packaged in a box	<b>SC</b>	Sub-cooling circuit
<b>Feet</b>	Feet-mounted	<b>kW</b>	Spray water kit
<b>SW</b>	Safety Switch	<b>FL</b>	Flanges
<b>CB</b>	Terminal Box	<b>FH</b>	Fan ring heater
<b>B</b>	Basic Switch Board	<b>IS</b>	Insulated Drip Tray
<b>BS</b>	Basic Switch Board + Signal	<b>RH</b>	Reheating coil
<b>BP</b>	Basic Switch Board + Step Control Pressure	<b>SR</b>	Air socket adapter ring
<b>BT</b>	Basic Switch Board + Step Control Temperature	<b>CW</b>	Air throw fan cowling
<b>BSP</b>	Basic Switch Board + Step Control Pressure + Signal	<b>ER</b>	120° elbow reducer
<b>BST</b>	Basic Switch Board + Step Control Temp. + Signal	<b>HN</b>	Hinged fan cowling
<b>BFP</b>	Basic Switch Board + Speed Control Pressure		
<b>BFT</b>	Basic Switch Board + Speed Control Temperature		
<b>BSFP</b>	Basic Switch Board + Speed Control Pres. + Signal		
<b>BSFT</b>	Basic Switch Board + Speed Control Temp. + Signal		
<b>BI</b>	Basic Switch Board + Frequency Converter (Inverter)		
<b>BSI</b>	Basic Switch Board + Frequency Converter (Inverter) + Signal		
<b>C</b>	Switch Board + Cooling fan		
<b>R</b>	Switch Board + Resistor		
<b>F</b>	Switch Board + Cooling fan + Resistor		
<b>PT</b>	Ammonia pump top		
<b>PB</b>	Ammonia pump bottom		
<b>AL</b>	Aluminium casing		
<b>SS</b>	Stainless Steel casing		
<b>AP</b>	Pre-painted Aluminium casing		
<b>PL</b>	Plastic casing		
<b>E</b>	Electrical defrost		
<b>LE</b>	Low Electrical defrost		
<b>A</b>	Air Defrost		
<b>HG</b>	Hot Gas Defrost		
<b>HG+E</b>	Hot Gas Defrost + Electrical Defrost on drip tray		
<b>W</b>	Water Defrost		
<b>W+E</b>	Water Defrost + Electrical Defrost on drip tray		

Note: valid for the entire product range

# AlfaCubic

## Product Description

### Applications

Units designed for use in small and medium cold rooms ranging from 10 to 400m<sup>3</sup>. Range of capacities from 1.5 to 57kW. Models calculated for fast and simple maintenance with easy access for inspection (DX or pump, HFC, NH<sub>3</sub> or CO<sub>2</sub> and Brine unit cooler.)

### Standard design

#### Coil

Coil manufactured from corrugated aluminium fins and copper rippled tubes with a diameter of 12mm for DX; smooth tubes with a 12mm diameter for Brine and 16mm stainless steel tubes for NH<sub>3</sub> units and CO<sub>2</sub> units.

#### Casing

The casing is manufactured from pre-painted aluminium sheets (RAL 9010), which are protected by plastic film for extra protection during transit.

### Benefits

- Low power consumption fan motor
- Low noise level
- Compact design
- Easy maintenance and access

### Options

- Fan pre-wired to main terminal box
- 6-pole, 230V/1ph (diameter 350, 400 and 500mm)
- 4-pole, 400V/3ph (all models)
- 6-pole, 400V/3ph (diameter 400 and 500mm)
- Local safety switch wired
- Air throw fan cowling
- Air sock adapter ring
- Fan ring heater
- Reheating coil
- Many fin spacing options
- Pre-coated fins
- Cataphoresis coil treatment
- Stainless steel tubes
- Stainless steel casing
- Insulated drip tray
- Drain-pipe flexible electrical heater
- Carbon Steel Connection
- Electric defrost
- Hot gas defrost (including the drip tray).
- Hot gas defrost in the coil and electric defrost in the drip tray.



### Fans

Single-phase motors 230V-50Hz, or three-phase 400V-50Hz, protection class IP54 according to DIN 40050. The motors are executed with a thermo contact. the fans are suitable for operation in air temp. application between -40°C and +40°C.

For air temperature lower than +20°C, the full load current (FLC) can be calculated by using the correction factor table. The overload protectors should have a 20% margin to accommodate fan motor supplier variations.

T [°C]	20	10	0	-10	-15	-20	-25	-30
Fc	1	1,04	1,08	1,12	1,14	1,16	1,18	1,2

Model	Capacity* SC 2	Capacity* SC 3	Air Flow	Air Throw		Surface	Tube Volume	Defrost			Fan motors	Motor data	Noise	Connections		Weight
	kW	kW	m <sup>3</sup> /h	-	Alfa Streamer	m <sup>2</sup>	dm <sup>3</sup>	W			n°x Ø mm		dB(A)	mm		Kg
	DT=8K Tev=-8°C	DT=7K Tev=-25°C		m	E			HG+E	FRH	(5m)			inlet	outlet		
<b>Fin spacing 4 mm / High speed Rotation</b>																
GLE251A4	2,2	1,7	1546	13	-	12,8	1,3	1050	270	300	1x250	P=150W I <sub>n</sub> =0.60A n=2500min-1 V=230V 2 poles	64	1/2"SAE	12	16
GLE251B4	2,7	2,0	1435	12	-	19,2	2,0	1440	270	300	1x250		64	1/2"SAE	12	16
GLE252A4	4,4	3,5	3092	15	-	25,6	2,7	2100	540	600	2x250		67	1/2"SAE	22	25
GLE252B4	5,5	4,2	2870	14	-	38,4	4,0	2880	540	600	2x250		67	1/2"SAE	22	30
GLE253A4	6,6	4,9	4639	16	-	38,4	4,0	3160	800	900	3x250		69	1/2"SAE	22	36
GLE253B4	7,6	5,1	4306	15	-	57,7	6,0	4340	800	900	3x250		69	1/2"SAE	22	42
GLE351A4	3,5	2,8	2365	14	-	21,4	2,2	1440	270	300	1x350	P=150W I <sub>n</sub> =0.66A n=1400min-1 V=230V 4 poles	57	1/2"SAE	22	30
GLE351B4	4,4	3,4	2206	13	-	32	3,4	1830	270	300	1x350		57	1/2"SAE	22	38
GLE352A4	7,1	5,5	4731	16	-	42,7	4,5	2880	540	600	2x350		60	1/2"SAE	24	42
GLE352B4	8,6	6,4	4412	15	-	64,1	6,7	3660	540	600	2x350		60	1/2"SAE	24	49
GLE353A4	10,6	8,2	7096	17	-	64,1	6,7	4340	800	900	3x350		62	1/2"SAE	28	58
GLE353B4	13,2	10,1	6618	16	-	96,1	10,0	5520	800	900	3x350		62	5/8"SAE	28	67
GLE354A4	14,1	10,8	9461	18	-	85,4	8,9	5710	1000	1200	4x350	63	5/8"SAE	35	84	
GLE354B4	17,5	13,0	8824	17	-	128	13,4	7280	1000	1200	4x350	63	5/8"SAE	35	88	
GLE401B4	6,2	4,9	3164	19	38	43,8	4,6	3600	450	350	1x400	P=250W I <sub>n</sub> =1.2A n=1430min-1 V=230V 4 poles	56	1/2"SAE	24	45
GLE401C4	7,0	5,3	2997	18	36	58,4	6,1	4500	450	350	1x400		56	1/2"SAE	24	50
GLE402B4	12,6	9,7	6374	21	42	90	9,4	7200	900	700	2x400		59	5/8"SAE	35	90
GLE402C4	14,3	11,0	6048	21	42	120	12,5	9000	900	700	2x400		59	5/8"SAE	35	95
GLE403B4	19,0	14,5	9583	23	46	136	14,2	10000	1250	1050	3x400		61	22	42	120
GLE403C4	21,3	16,1	9098	22	44	182	18,9	12500	1250	1050	3x400		61	22	42	130
GLE 502A4	19,0	13,3	15308	37	74	107	12,0	8000	1600	900	2x500	P=770W I <sub>n</sub> =3.4A n=1210min-1 V=230V 4 poles	64	16	35	108
GLE 502B4	25,0	18,5	14424	35	70	160	18,0	11200	1600	900	2x500		64	22	35	127
GLE 502C4	28,4	21,1	13606	34	68	214	23,0	14400	1600	900	2x500		64	22	42	145
GLE 503B4	37,2	26,9	21672	37	74	242	26,0	19600	2800	1350	3x500		66	22	42	178
GLE 503C4	42,9	32,0	20452	36	72	323	35,0	25200	2800	1350	3x500		66	28	42	195
GLE 504B4	49,9	36,4	28949	39	78	324	35,0	23400	2600	1800	4x500		67	28	54	225
GLE 504C4	75,4	42,9	27298	37	74	431	46,0	28600	2600	1800	4x500	67	28	54	273	
<b>Fin spacing 5,5 mm / High speed Rotation</b>																
RLE251A55	1,8	1,45	1596	14	-	9,5	1,3	1050	270	300	1x250	P=150W I <sub>n</sub> =0.60A n=2500min-1 V=230V 2 poles	62	1/2"SAE	12	15
RLE251B55	2,4	1,8	1499	13	-	14,2	2,0	1440	270	300	1x250		64	1/2"SAE	12	17
RLE252A55	3,7	3,0	3192	16	-	18,9	2,7	2100	540	600	2x250		67	1/2"SAE	22	24
RLE252B55	4,9	3,7	2997	15	-	28,4	4,0	2880	540	600	2x250		67	1/2"SAE	22	29
RLE253A55	5,6	4,3	4788	17	-	28,4	4,0	3160	800	900	3x250		69	1/2"SAE	22	35
RLE253B55	6,9	4,8	4496	16	-	42,6	6,0	4340	800	900	3x250		69	1/2"SAE	22	40
RLE351A55	2,9	2,3	2427	15	-	15,8	2,2	1440	270	300	1x350	P=150W I <sub>n</sub> =0.66A n=1400min-1 V=230V 4 poles	57	1/2"SAE	22	29
RLE351B55	3,8	3,0	2295	14	-	23,6	3,4	1830	270	300	1x350		57	1/2"SAE	22	36
RLE352A55	5,9	4,7	4853	17	-	31,5	4,5	2880	540	600	2x350		60	1/2"SAE	24	40
RLE352B55	7,7	5,8	4590	16	-	47,3	6,7	3660	540	600	2x350		60	1/2"SAE	24	47
RLE353A55	8,9	7,0	7280	18	-	47,3	6,7	4340	800	900	3x350		62	1/2"SAE	28	56
RLE353B55	11,7	9,0	6886	17	-	70,9	10,0	5520	800	900	3x350		62	5/8"SAE	28	65
RLE354A55	12,0	9,3	9707	19	-	63,0	8,9	5710	1000	1200	4x350	63	5/8"SAE	35	82	
RLE354B55	15,5	11,8	9181	18	-	94,6	13,4	7280	1000	1200	4x350	63	5/8"SAE	35	86	
RLE401B55	5,4	4,3	3269	19	38	32,3	4,6	3600	450	350	1x400	P=250W I <sub>n</sub> =1.2A n=1430min-1 V=230V 4 poles	56	1/2"SAE	24	40
RLE401C55	6,3	4,8	3121	18	36	43,1	6,1	4500	450	350	1x400		56	1/2"SAE	24	45
RLE402B55	11,0	8,6	6579	22	44	66,4	9,4	7200	900	700	2x400		59	5/8"SAE	35	82
RLE402C55	13,0	10,0	6291	21	42	88,5	12,5	9000	900	700	2x400		59	5/8"SAE	35	90
RLE403B55	16,7	12,9	9888	24	48	100	14,2	10000	1250	1050	3x400		61	22	42	114
RLE403C55	19,4	14,9	9459	23	46	134	18,9	12500	1250	1050	3x400		61	22	42	125
RLE 502A55	16,4	11,9	15568	37	74	79	12,0	8000	1600	900	2x500	P=770W I <sub>n</sub> =3.4A n=1210min-1 V=230V 4 poles	64	16	35	102
RLE 502B55	22,0	16,6	14814	36	72	118	18,0	11200	1600	900	2x500		64	22	35	119
RLE 502C55	25,7	19,5	14079	34	68	158	23,0	14400	1600	900	2x500		64	22	42	134
RLE 503B55	32,9	24,5	22251	38	76	179	26,0	19600	2800	1350	3x500		66	22	42	165
RLE 503C55	38,9	29,5	21178	36	72	238	35,0	25200	2800	1350	3x500		66	28	42	178
RLE 504B55	44,1	32,9	29689	39	78	239	35,0	23400	2600	1800	4x500		67	28	54	207
RLE 504C55	52,0	39,5	28263	38	76	318	46,0	28600	2600	1800	4x500	67	28	54	250	

\*Nominal capacity according to ENV328 and Eurovent regulations (refrigerant R404A, ΔT1=T<sub>INair</sub>-T<sub>ev</sub>). Use external equalised thermostatic expansion valve.

Model	Capacity* SC 2	Capacity* SC 3	Air Flow	Air Throw		Surface	Tube Volume	Defrost			Fan mo- tors	Motor data	Noise	Connections		Weight
	kW	kW	m <sup>3</sup> /h	-	Alfa Streamer	m <sup>2</sup>	dm <sup>3</sup>	W			n*x Ø mm		dB(A)	mm		Kg
	DT=8K Tev=-8°C	DT=7K Tev=-25°C		m	E			HG+E	FRH	(5m)			inlet	outlet		
<b>Fin spacing 7 mm / High speed Rotation</b>																
BLE251A7	1,6	1,3	1616	14	-	7,5	1,3	1050	270	300	1x250	P=150W I <sub>n</sub> =0.60A n=2500min-1 V=230V 2 poles	64	1/2"SAE	12	14
BLE251B7	2,2	1,6	1526	13	-	11,3	2,0	1440	270	300	1x250		64	1/2"SAE	12	16
BLE252A7	3,2	2,5	3232	16	-	15,1	2,7	2100	540	600	2x250		67	1/2"SAE	22	22
BLE252B7	4,3	3,4	3053	15	-	22,6	4,0	2880	540	600	2x250		67	1/2"SAE	22	27
BLE253A7	4,9	3,7	4848	17	-	22,6	4,0	3160	800	900	3x250		69	1/2"SAE	22	33
BLE253B7	6,3	4,5	4579	16	-	33,9	6,0	4340	800	900	3x250		69	1/2"SAE	22	38
BLE351A7	2,6	2,0	2455	15	-	12,6	2,2	1440	270	300	1x350	P=150W I <sub>n</sub> =0.66A n=1400min-1 V=230V 4 poles	57	1/2"SAE	22	27
BLE351B7	3,4	2,7	2338	14	-	18,8	3,4	1830	270	300	1x350		57	1/2"SAE	22	34
BLE352A7	5,1	4,1	4910	17	-	25,1	4,5	2880	540	600	2x350		60	1/2"SAE	24	38
BLE352B7	6,9	5,3	4676	16	-	37,7	6,7	3660	540	600	2x350		60	1/2"SAE	24	45
BLE353A7	7,7	6,1	7365	18	-	37,7	6,7	4340	800	900	3x350		62	1/2"SAE	28	54
BLE353B7	10,4	8,1	7014	17	-	56,5	10,0	5520	800	900	3x350		62	5/8"SAE	28	63
BLE354A7	10,4	8,2	9819	19	-	50,2	8,9	5710	1000	1200	4x350	63	5/8"SAE	35	80	
BLE354B7	13,9	10,6	9352	18	-	75,3	13,4	7280	1000	1200	4x350	63	5/8"SAE	35	82	
BLE401B7	4,7	3,8	3321	19	38	25,8	4,6	3600	450	350	1x400	P=250W I <sub>n</sub> =1.2A n=1430min-1 V=230V 4 poles	56	1/2"SAE	24	38
BLE401C7	5,7	4,4	3184	19	38	34,3	6,1	4500	450	350	1x400		56	1/2"SAE	24	42
BLE402B7	9,8	7,7	6680	22	44	52,9	9,4	7200	900	700	2x400		59	5/8"SAE	35	76
BLE402C7	11,7	9,7	6413	22	44	70,5	12,5	9000	900	700	2x400		59	5/8"SAE	35	85
BLE403B7	14,8	11,6	10038	24	48	80,0	14,2	10000	1250	1050	3x400		61	22	42	108
BLE403C7	17,7	13,6	9641	23	46	107	18,9	12500	1250	1050	3x400		61	22	42	118
BLE 502A7	14,5	11,2	15745	38	76	63,0	12,0	8000	1600	900	2x500	P=770W I <sub>n</sub> =3,4A n=1210min-1 V=230V 4 poles	64	16	35	97
BLE 502B7	19,5	15,2	15076	37	74	94,0	18,0	11200	1600	900	2x500		64	22	35	111
BLE 502C7	23,4	17,8	14410	35	70	126	23,0	14400	1600	900	2x500		64	22	42	124
BLE 503B7	29,3	22,2	22641	39	78	142	26,0	19600	2800	1350	3x500		66	22	42	153
BLE 503C7	35,3	27,0	21671	37	74	190	35,0	25200	2800	1350	3x500		66	28	42	162
BLE 504B7	39,2	29,8	30206	40	80	190	35,0	23400	2600	1800	4x500		67	28	54	192
BLE 504C7	47,2	36,2	28918	39	78	254	46,0	28600	2600	1800	4x500		67	28	54	230

\*Nominal capacity according to EN328 and Eurovent regulations (refrigerant R404A,  $\Delta T1 = T_{inair} - T_{ev}$ ). Use external equalised thermostatic expansion valve.



# AlfaCubic HP

## Product Description

### Applications

Units designed for use in medium sized cold rooms up to 400m<sup>3</sup>. Models calculated for simple and fast maintenance with immediate access to inspection areas. This series is available as an evaporator in pump operation for CO<sub>2</sub> refrigerant and with a design pressure of D<sub>P</sub>=50bar. The unit operates at temperatures down to -50°C in deep freeze rooms.

### Standard design

#### Coil

Coil manufactured with corrugated aluminium fins and smooth stainless steel tubes, nominal diameter 16 mm. The tube pattern is staggered and the available fin spacing is from 7 to 12 mm.

#### Casing

The casing is manufactured from pre-painted aluminium sheets (RAL 9010), which are protected by plastic film for extra protection during transit.

### Benefits

Product details:

- Large heat exchanger surface
- Low power consumption fan motor
- Low noise level
- Compact design
- Easy maintenance and access

System details:

- Smaller components such as coolers: Compressor and piping system
- No recycling necessary
- Cheap refrigerant
- Increased efficiency

### Options

- Fan pre-wired to main terminal box
- 6-pole, 230V/1ph (all models)
- 4-pole, 400V/3ph (all models)
- 6-pole, 400V/3ph (all models)
- Local safety switch wired
- Air throw fan cowl
- Air sock adapter ring
- Fan ring heater
- Many fin spacing options
- Pre-coated fins
- Cataphoresis coil treatment



- Stainless steel casing
- Insulated drip tray
- Drain-pipe flexible electrical heater
- Carbon Steel Connection
- Electric defrost
- Hot gas defrost (including the drip tray).
- Hot gas defrost in the coil and electric defrost in the drip tray.

### Fans

Single-phase motors 230V-50Hz, or three-phase 400V-50Hz, protection class IP54 according to DIN 40050. The motors are fitted with a thermal contact. The fans are suitable for operation in air temp. application between -40°C and +40°C.

For air temperature lower than +20°C, the full load current (FLC) can be calculated by using the correction factor table. The overload protectors should have a 20% margin to accommodate fan motor supplier variations.

T [°C]	20	10	0	-10	-15	-20	-25	-30
Fc	1	1,04	1,08	1,12	1,14	1,16	1,18	1,2

Model	Capacity *	Air Flow	Air Throw		Surface	Tube volume	Defrost			Fan motors	Motor data	Noise	Connections		Weight
	kW	m <sup>3</sup> /h	-	Alfa Streamer	m <sup>2</sup>	dm <sup>3</sup>	W			n°x ø mm		dB(A)	mm		Kg
	DT=10K Tev=-40°C		m	E			HG+E	FRH	(5m)			inlet	outlet		
<b>7 mm fin spacing / High speed Rotation</b>															
BLH401B7	6,7	3141	19	38	25,1	7,8	3600	450	350	1x400	P=285W I <sub>n</sub> =1,2A n=1430min <sup>-1</sup> V=230V 4 poles	62	1"	1" 1/4	38
BLH401C7	7,7	2971	18	36	33,5	10,5	4500	450	350	1x400		62	1"	1" 1/4	42
BLH402B7	14,5	6330	22	44	51,6	16,1	7200	900	700	2x400		65	1"	1" 1/4	76
BLH402C7	16,6	5998	21	42	68,8	21,5	9000	900	700	2x400		65	1"	1" 1/4	85
BLH403B7	21,6	9517	23	46	78,0	24,4	10000	1250	1050	3x400		67	1" 1/4	1" 1/2	108
BLH403C7	24,7	9023	23	46	104	32,5	12500	1250	1050	3x400	67	1" 1/4	1" 1/2	118	
BLH502A7	23,0	15329	37	74	61,3	17,9	8000	1600	900	2x500	P=770W I <sub>n</sub> =1,35A n=1210min <sup>-1</sup> V=230V 4 poles	64	1"	1" 1/4	140
BLH502B7	30,0	14465	36	72	92,0	26,9	11200	1600	900	2x500		64	1"	1" 1/4	150
BLH502C7	34,6	13677	34	68	123	35,6	14400	1600	900	2x500		64	1" 1/4	1" 1/2	160
BLH503B7	44,6	21736	38	76	139	40,6	19600	2800	1350	3x500		66	1" 1/4	1" 1/2	200
BLH503C7	51,8	20561	36	72	185	54,2	25200	2800	1350	3x500		66	1" 1/4	1" 1/2	210
BLH504B7	56,3	29007	39	78	186	54,3	23400	2600	1800	4x500	67	1" 1/4	2"	230	
BLH504C7	66,3	27446	38	76	248	72,4	28600	2600	1800	4x500	67	1" 1/4	2"	240	
<b>8 mm fin spacing / High speed Rotation</b>															
BLH401B8	6,3	3179	19	38	22,3	7,8	3600	450	350	1x400	P=285W I <sub>n</sub> =1,2A n=1430min <sup>-1</sup> V=230V 4 poles	62	1"	1" 1/4	38
BLH401C8	7,3	3016	18	36	29,7	10,5	4500	450	350	1x400		62	1"	1" 1/4	42
BLH402B8	13,7	6405	22	44	45,7	16,1	7200	900	700	2x400		65	1"	1" 1/4	76
BLH402C8	15,8	6085	21	42	60,9	21,5	9000	900	700	2x400		65	1"	1" 1/4	85
BLH403B8	20,4	9629	23	46	69,2	24,4	10000	1250	1050	3x400		67	1" 1/4	1" 1/2	108
BLH403C8	23,5	9154	23	46	92,2	32,5	12500	1250	1050	3x400	67	1" 1/4	1" 1/2	118	
BLH502A8	21,4	15453	37	74	54,4	17,9	8000	1600	900	2x500	P=770W I <sub>n</sub> =1,35A n=1210min <sup>-1</sup> V=230V 4 poles	64	1"	1" 1/4	140
BLH502B8	28,1	14640	36	72	81,6	26,9	11200	1600	900	2x500		64	1"	1" 1/4	150
BLH502C8	32,9	13888	34	68	108,7	35,6	14400	1600	900	2x500		64	1" 1/4	1" 1/2	160
BLH503B8	42,1	21996	38	76	123,1	40,6	19600	2800	1350	3x500		66	1" 1/4	1" 1/2	200
BLH503C8	49,5	20876	36	72	164,1	54,2	25200	2800	1350	3x500		66	1" 1/4	1" 1/2	210
BLH504B8	53,6	29351	39	78	164,6	54,3	23400	2600	1800	4x500	67	1" 1/4	2"	230	
BLH504C8	63,6	27864	38	76	219,4	72,4	28600	2600	1800	4x500	67	1" 1/4	2"	240	
<b>10 mm fin spacing / High speed Rotation</b>															
BLH401B10	5,7	3239	19	38	18,3	7,8	3600	450	350	1x400	P=285W I <sub>n</sub> =1,2A n=1430min <sup>-1</sup> V=230V 4 poles	62	1"	1" 1/4	38
BLH401C10	6,7	3085	18	36	24,4	10,5	4500	450	350	1x400		62	1"	1" 1/4	42
BLH402B10	12,4	6520	22	44	37,5	16,1	7200	900	700	2x400		65	1"	1" 1/4	76
BLH402C10	14,5	6221	21	42	50,0	21,5	9000	900	700	2x400		65	1"	1" 1/4	85
BLH403B10	18,3	9801	23	46	56,7	24,4	10000	1250	1050	3x400		67	1" 1/4	1" 1/2	108
BLH403C10	21,6	9356	23	46	75,6	32,6	12500	1250	1050	3x400	67	1" 1/4	1" 1/2	118	
BLH502A10	18,8	15635	37	74	44,6	17,9	8000	1600	900	2x500	P=770W I <sub>n</sub> =1,35A n=1210min <sup>-1</sup> V=230V 4 poles	64	1"	1" 1/4	140
BLH502B10	25,2	14905	36	72	66,9	26,9	11200	1600	900	2x500		64	1"	1" 1/4	150
BLH502C10	30,0	14210	34	68	89,2	35,6	14400	1600	900	2x500		64	1" 1/4	1" 1/2	160
BLH503B10	38,0	22390	38	76	101	40,6	19600	2800	1350	3x500		66	1" 1/4	1" 1/2	200
BLH503C10	45,4	21357	36	72	135	54,2	25200	2800	1350	3x500		66	1" 1/4	1" 1/2	210
BLH504B10	49,0	29874	39	78	135	54,3	23400	2600	1800	4x500	67	1" 1/4	2"	230	
BLH504C10	59,0	28503	38	76	180	72,4	28600	2600	1800	4x500	67	1" 1/4	2"	240	
<b>12 mm fin spacing / High speed Rotation</b>															
BLH401B12	5,2	3283	19	38	15,6	7,8	3600	450	350	1x400	P=285W I <sub>n</sub> =1,2A n=1430min <sup>-1</sup> V=230V 4 poles	62	1"	1" 1/4	38
BLH401C12	6,2	3137	18	36	20,8	10,5	4500	450	350	1x400		62	1"	1" 1/4	42
BLH402B12	11,3	6606	22	44	32,0	16,1	7200	900	700	2x400		65	1"	1" 1/4	76
BLH402C12	13,5	6323	21	42	42,7	21,5	9000	900	700	2x400		65	1"	1" 1/4	85
BLH403B12	16,7	9928	23	46	48,4	24,4	10000	1250	1050	3x400		67	1" 1/4	1" 1/2	108
BLH403C12	20,0	9507	23	46	64,6	32,5	12500	1250	1050	3x400	67	1" 1/4	1" 1/2	118	
BLH502A12	16,9	15765	37	74	38,1	17,9	8000	1600	900	2x500	P=770W I <sub>n</sub> =1,35A n=1210min <sup>-1</sup> V=230V 4 poles	64	1"	1" 1/4	140
BLH502B12	23,0	15097	36	72	57,1	26,9	11200	1600	900	2x500		64	1"	1" 1/4	150
BLH502C12	27,7	14450	34	68	76,2	35,6	14400	1600	900	2x500		64	1" 1/4	1" 1/2	160
BLH503B12	34,8	22675	38	76	86,2	40,6	19600	2800	1350	3x500		66	1" 1/4	1" 1/2	200
BLH503C12	42,1	21713	36	72	115	54,1	25200	2800	1350	3x500		66	1" 1/4	1" 1/2	210
BLH504B12	45,2	30253	39	78	115	54,3	23400	2600	1800	4x500	67	1" 1/4	2"	230	
BLH504C12	55,0	28975	38	76	154	72,4	28600	2600	1800	4x500	67	1" 1/4	2"	240	

\* Nominal capacity according to ENV328 and Eurovent rules (refrigerant R744A, ΔT1=T<sub>INair</sub>-T<sub>ev</sub>). Use external equalised thermostatic expansion valve.

# AlfaCubic

## Drawings

MODEL	DIMENSIONS (mm)						
	DX	Brine/NH <sub>3</sub> /HP	ALL	ALL	ALL	ALL	ALL
	A	A	B	C	D	E	F
GL/RL/BL 251	840	970	530	460	395	410	250
GL/RL/BL 252	1340	1470	1030	460	395	410	250
GL/RL/BL 253	1840	1970	1530	460	395	410	250
GL/RL/BL 351	840	970	530	460	585	410	300
GL/RL/BL 352	1340	1470	1030	460	585	410	300
GL/RL/BL 353	1840	1970	1530	460	585	410	300
GL/RL/BL 354	2340	2470	2030	460	585	410	300
GL/RL/BL 401	910	1040	600	630	685	530	450
GL/RL/BL 402	1510	1640	1200	630	685	530	450
GL/RL/BL 403	2110	2240	1800	630	685	530	450
GL/RL/BL 502	2140	2140	1700	650	830	530	450
GL/RL/BL 503	2990	2990	2550	650	830	530	450
GL/RL/BL 504	3840	3840	3400	650	830	530	450

We reserve the right to change our technical data without prior notice.

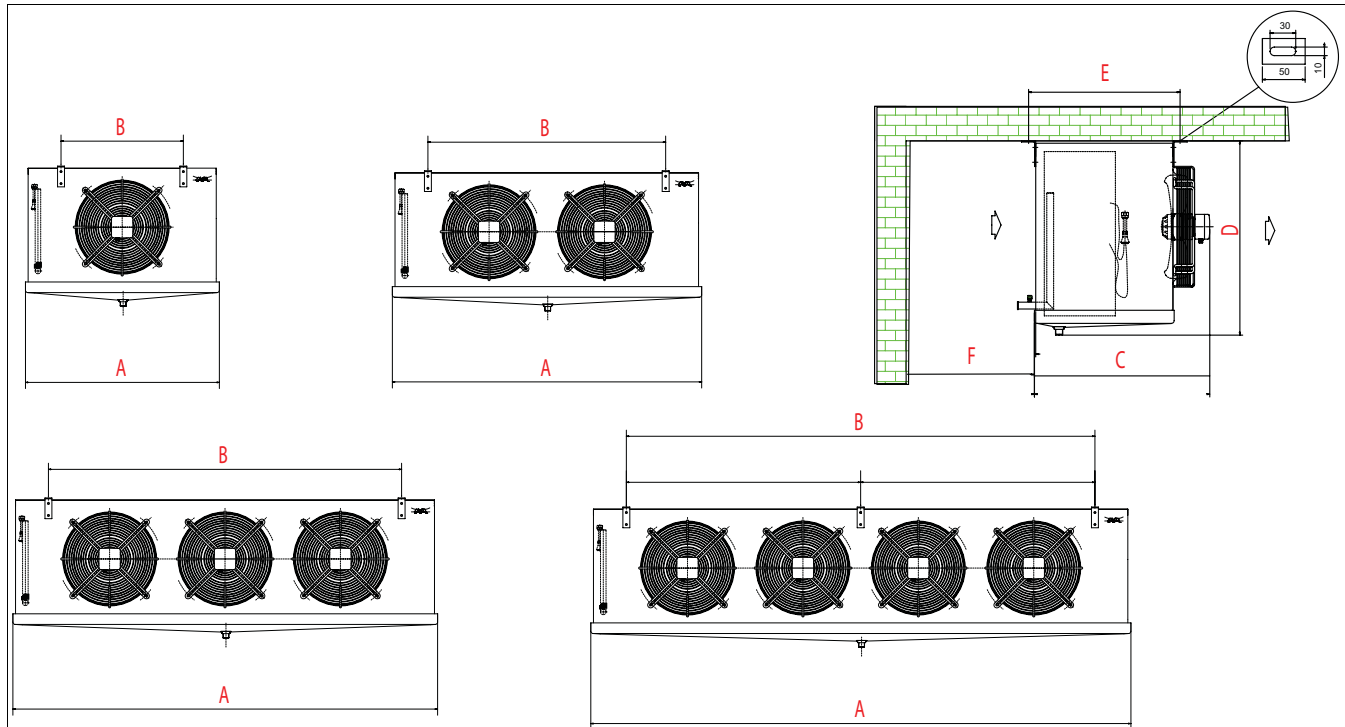

## AlfaCubic

## Options

## Fan pre-wired to main terminal box

Fan motor pre-wired to main terminal junction box IP55, in painted galvanized steel.  
See Electrical Data page.

**Model:**  
**ALL APPLICATIONS**  
All Models

## Fan motors



6-pole, 230V/1Ph  
4-pole, 400V/3Ph  
6-pole, 400 V/3ph

**Model:**  
**ALL APPLICATIONS**  
For diameter:  
350mm  
400mm  
500mm

## Local safety switch wired

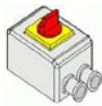

Local safety switch and cabling for each electric fan motor.  
Plastic covering box, IP66, nominal current 16A – 3 phases, insulated voltage 600V.  
Reference and standard CE/UL/CSA. Per unit.

**Model:**  
**ALL APPLICATIONS**  
All Models

## Fan ring heater (FRH)



**Application:**  
To prevent the freezing up of the fan blades at the collar in extremely humid conditions during defrost in cooling or freezing rooms.  
**Supply conditions:**  
Electric heater with stainless steel shell, stainless steel fixing spring and connection box.

**Model:**  
**ALL APPLICATIONS**  
All Models

## Air sock adapter ring

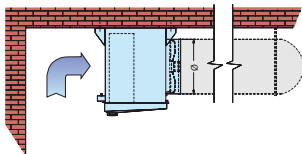

**Applications:** Flower, fruit and vegetable storage areas, supermarkets, bakeries, slaughter houses and other meat-processing operations. Price per unit cooler.  
**Benefits:** Equal cooling effect without draught, even temperature distribution, comfort in cold working areas.  
The sock reduces the airflow and capacity. Please contact Alfa Laval for design and unit section.

**Model:**  
Ø 400/500mm

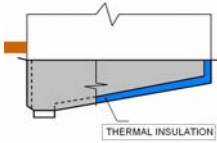
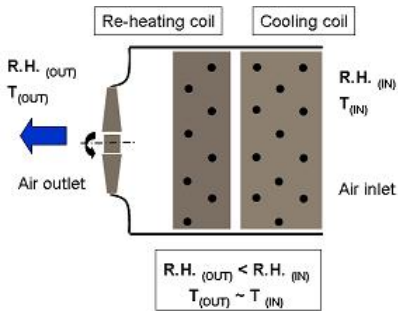
<b>AlfaStreamer</b>		
	<p>Increase of the axial airflow speed by deviation of centrifugal and circular flow components.                  Increased air throw for refrigeration applications.                  Applications: cold stores, working rooms</p>	<p><b>Model:</b>                  ALL APPLICATIONS                  Ø 400mm                  No. of fans                  2, 3, 4, 5                  Ø 500 mm                  No. of fans                  2, 3, 4, 5</p>
<b>Cabinet made entirely of stainless steel</b>		
<p>Casework component in stainless steel AISI 304.                  Application Use: More information on corrosion prevention can be found in the Miscellaneous section.</p>		<p><b>Model:</b>                  ALL APPLICATIONS                  All Models</p>
<b>Insulated drip tray</b>		
	<p><b>Construction:</b> Sandwich manufactured with two aluminium shells and 12mm of polyethylene insulation in between.  <b>Features:</b> The insulation prevents water condensing on the bottom side of the drip-tray and reduces the transfer of the defrost heat into the cold room. It can be combined with Electrical or Hot Gas defrost.  <b>Applications:</b> Room temperatures below -25°C and food processing rooms.</p>	<p><b>Model:</b>                  ALL APPLICATIONS                  All Models</p>
<b>Cable electric heater</b>		
<p>Applications:                  We recommend that you heat the drain pipeline while defrosting to prevent ice forming in the pipes.                  The flexible electric heater can easily be placed inside the pipe.                  Power: 70W.                  Voltage: 230V</p>		<p><b>Model:</b>                  ALL APPLICATIONS                  All Models</p>
<b>Reheating coil</b>		
	<p><b>Use:</b>                  It's an additional coil used for dehumidifying or heating the air outlet of the evaporator. It can be one or two rows deep. There are two systems:                  - using warm water with a minimal flow rate providing small air temperature rise.                  - Using electric heaters fixed into the finned tube coil.  <b>Quick selection:</b></p> <ul style="list-style-type: none"> <li>• Product available: AlfaCubic Dx, Ammonia.</li> <li>• Permanent 2 row tube for reheating coil.</li> <li>• Coil sizes with reheating water:                         <ul style="list-style-type: none"> <li>• A (cooling size) + 2 rows (reheating coil)</li> <li>• B (cooling size) + 2 rows (reheating coil)</li> <li>• In case C coil size: due to space limitations in the unit, the cooling coil will be B with + 2 rows for reheating</li> </ul> </li> </ul>	<p><b>Model:</b>                  DX/Ammonia                  All Models, except                  Ø 500</p>
<b>Coil Treatment / Material</b>		
<p><b>Pre-coated fins:</b> Epoxy-coated, pre-painted aluminium fins.  <b>Cataphoresis treatment:</b> An electrolytic process is achieved by submerging the coil in a paint bath, where it acts as a cathode and gets completely coated in an epoxy paint, which gives exceptional protection against corrosion. Recommended for alkaline or salty atmospheres.  <b>Stainless steel tubes with aluminium fins:</b> The coil is available in stainless steel tubes with aluminium fins.                  Application Use: More information on corrosion prevention can be found in the Miscellaneous section.</p>		<p><b>Model:</b>                  ALL APPLICATIONS                  All Models</p>



Special fin spacing		
	Different fin spacings are available for the series GL, RL, BL. Airflow and air flow are influenced by spacing variations.	<b>Model:</b> <b>ALL APPLICATIONS</b> All Models
Carbon Steel Connection		
	Additional end terminal connection for stainless steel headers.	<b>Model:</b> <b>ALL APPLICATIONS</b> NH <sub>3</sub>

# AlfaCubic

## Electrical data

### AlfaCubic junction box for motors

Series 250 / 350

#### Function

Junction box complete with screw-on cover, cable glands and terminal strip.

#### General data

Material: Plastic

IP Protection Class: Min IP55

Colour: Grey RAL7035

Insulation class: II

Ambient Temp.: -25°C Max +50°C

Weight: 0,5 kg

#### Dimensions

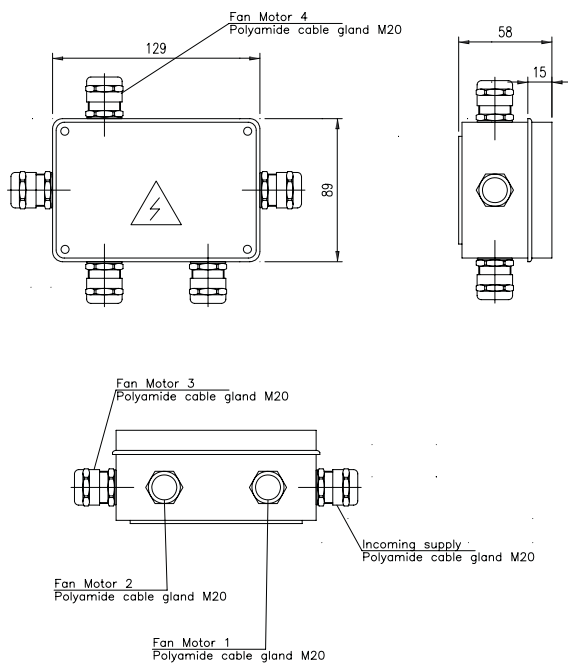

#### Electric wiring diagram

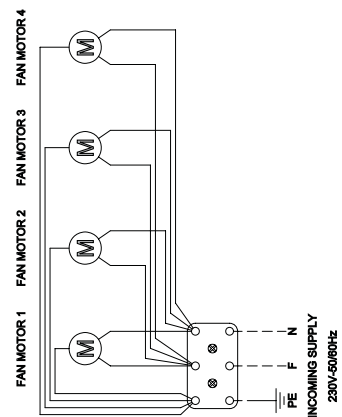

**AlfaCubic junction box for motors**

**Series 400 / 500**

**Function**

Metallic junction box complete with cable glands and terminal strip.

**General data**

- Material: Sheet of steel
- IP Protection Class: Min IP55
- Colour: Grey RAL7032
- Insulation class: I
- Ambient Temp.: -25°C Max +50°C
- Weight: approx. 4Kg

**Dimensions** **Electric wiring diagram**

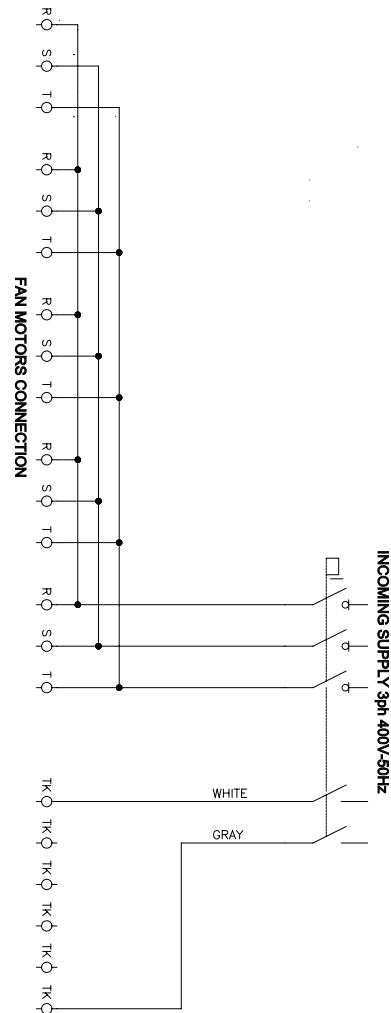
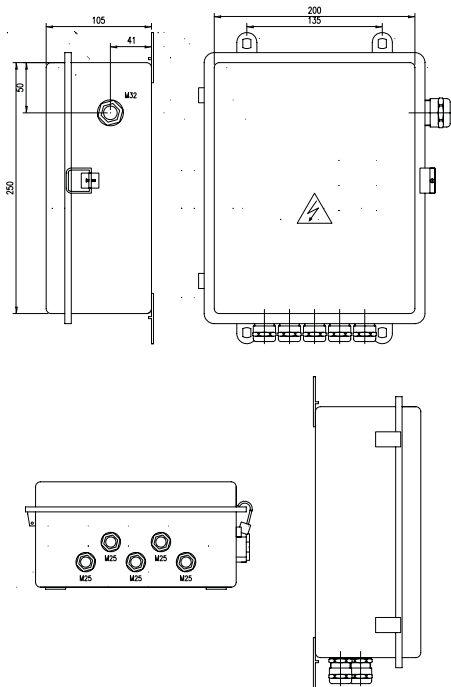

AlfaCubic junction box for "E" defrost

Series 250 / 350

Function

Junction box complete with screw-on cover, cable glands and terminal strip.

General data

Material: Plastic

IP Protection Class: Min IP55

Colour: Grey RAL7035

Insulation class: II

Ambient Temp.: -25°C Max +50°C

Weight: 0,5 kg

Dimensions Electric wiring diagram

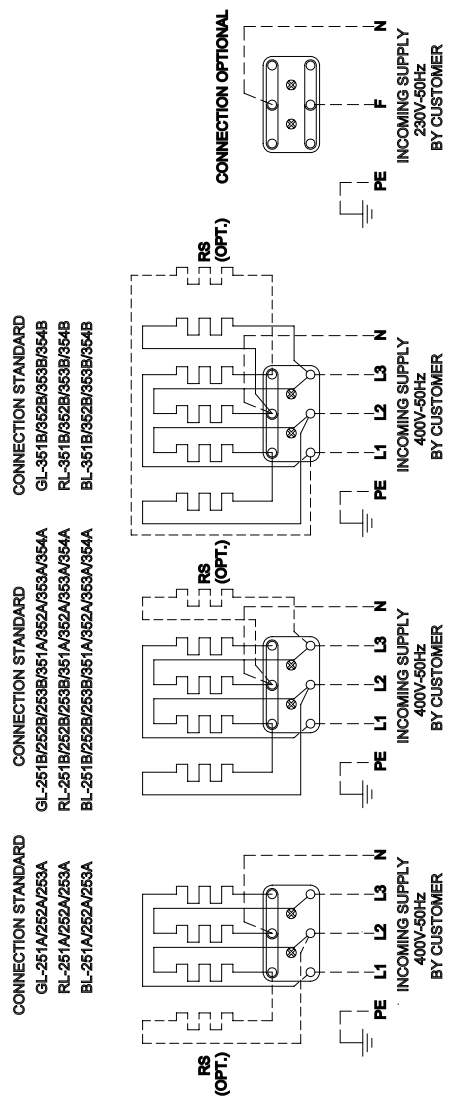
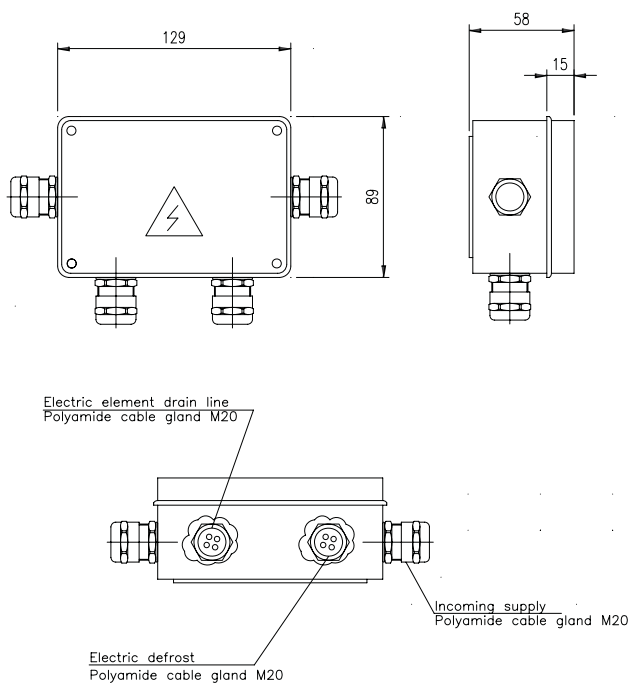

**AlfaCubic junction box for "E" defrost**

**Series 400 / 500**

**Function**

Metallic junction box complete with cable glands and terminal strip.

**General data**

- Material: Sheet of steel
- IP Protection Class: Min IP55
- Colour: Grey RAL7032
- Insulation class: I
- Ambient Temp.: -25°C Max +50°C
- Weight: approx. 4Kg

**Dimensions** **Electric wiring diagram**

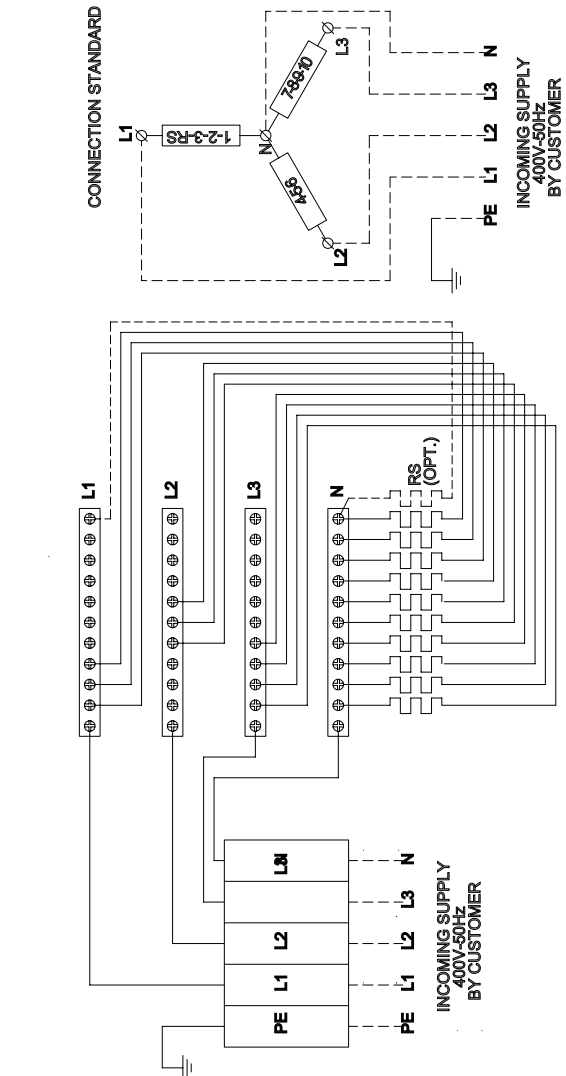
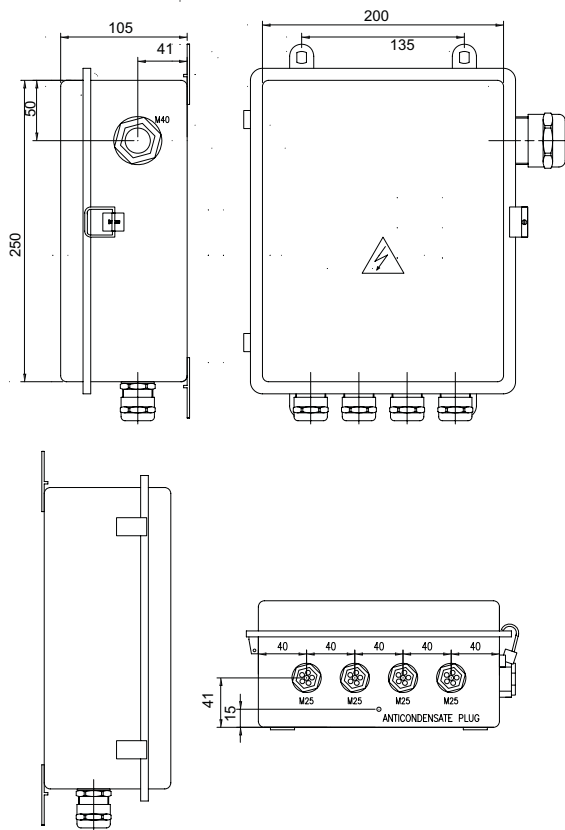



# AlfaCubic

## Electric Heater

### ALL SERIES

#### Function

The elements are designed to operate in a refrigeration field with high moisture rate.

Special care is taken in selecting the power supply, cables and insulation materials. Less stream (easy mounting)

#### General data

Model	Coil		Drip-tray	
	n°	Watt	n°	Watt
_251A	2	780	1	270
_251B	3	1170	1	270
_252A	2	1560	1	540
_252B	3	2340	1	540
_253A	2	2360	1	800
_253B	3	3540	1	800
_351A	3	1170	1	270
_351B	4	1560	1	270
_352A	3	2340	1	540
_352B	4	3120	1	540
_353A	3	3570	1	800
_353B	4	4760	1	800
_354A	3	4680	1	1000
_354B	4	6240	1	1000
_401B	7	3150	1	450
_401C	9	4050	1	450
_402B	7	6300	1	900
_402C	9	8100	1	900
_403B	7	8750	1	1250
_403C	9	11250	1	1250
_502A	4	6400	1	1600
_502B	6	9600	1	1600
_502C	8	12800	1	1600
_503B	6	16800	1	2800
_503C	8	22400	1	2800
_504B	8	20800	1	2600
_504C	10	26000	1	2600

We reserve the right to change our technical data without prior notice.

# AlfaCubic

## Code description

ALFACUBIC

		1	2	3	4	5	6	7	8	
		RL	W	S	25	1	A	40	E	S
GL	Green Line									
RL	Red Line									
BL	Blue Line									
<b>1) Application</b>										
E	Direct Expansion Evaporator									
W	Brine Unit Cooler									
A	Ammonia Pump Evaporator									
H	CO <sub>2</sub> High Pressure Pump									
<b>2) Noise level</b>										
S	4-pole fan motor									
L	6-pole fan motor									
<b>3) Fan diameter Ø</b>										
25	250 mm									
35	350 mm									
40	400 mm									
50	500 mm									
<b>4) Number of Fans</b>										
1 , 2 , 3, 4										
<b>5) Coil Size</b>										
A, B, C										
<b>6) Standard Fin Spacing</b>										
40	4 mm									
55	5,5 mm									
70 or 7	7 mm									
10	10 mm									
12	12 mm									
<b>7) Defrost</b>										
A	Air									
E	Electrical									
HG	Hot Gas									
HG+E	Hot Gas + Electrical									
<b>8) Fan motors</b>										
S	Single phase									
D/Y	Three-phase									

## General Alfa Select Air Legend

		Description 1		Description 2	
<b>D</b>	D fan cabling (three phase)	<b>BSFT</b>	Basic Switch Board + Speed Control Temp. + Signal	<b>AL</b>	Aluminium fin
<b>Y</b>	Y fan cabling (three phase)	<b>BI</b>	Basic Switch Board + Frequency Converter (Inverter)	<b>CU</b>	Copper fin
<b>D/Y</b>	D/Y fan cabling (three phase), single speed fan motor	<b>BSI</b>	Basic Switch Board + Frequency Converter (Inverter) + Signal	<b>PR</b>	Pre-coated fin
<b>S</b>	Single phase	<b>C</b>	Switch Board + Cooling fan	<b>SS</b>	Stainless steel tube
<b>P</b>	Packaged on a pallet	<b>R</b>	Switch Board + Resistor	<b>TH</b>	Thermoguard treatment
<b>CR</b>	Packaged in a crate	<b>F</b>	Switch Board + Cooling fan + Resistor	<b>CF</b>	Cataphoresis treatment
<b>BO</b>	Packaged in a box	<b>PT</b>	Ammonia pump top	<b>SC</b>	Sub-cooling circuit
<b>Feet</b>	Feet-mounted	<b>PB</b>	Ammonia pump bottom	<b>KW</b>	Spray water kit
<b>SW</b>	Safety Switch	<b>AL</b>	Aluminium casing	<b>FL</b>	Flanges
<b>CB</b>	Terminal Box	<b>SS</b>	Stainless Steel casing	<b>FH</b>	Fan ring heater
<b>B</b>	Basic Switch Board	<b>AP</b>	Pre-painted Aluminium casing	<b>IS</b>	Insulated Drip Tray
<b>BS</b>	Basic Switch Board + Signal	<b>PL</b>	Plastic casing	<b>RH</b>	Reheating coil
<b>BP</b>	Basic Switch Board + Step Control Pressure	<b>E</b>	Electrical defrost	<b>SR</b>	Air socket adapter ring
<b>BT</b>	Basic Switch Board + Step Control Temperature	<b>LE</b>	Low Electrical defrost	<b>CW</b>	Air throw fan cowling
<b>BSP</b>	Basic Switch Board + Step Control Pressure + Signal	<b>A</b>	Air Defrost	<b>ER</b>	120° elbow reducer
<b>BST</b>	Basic Switch Board + Step Control Temp. + Signal	<b>HG</b>	Hot Gas Defrost	<b>HN</b>	Hinged fan cowling
<b>BFP</b>	Basic Switch Board + Speed Control Pressure	<b>HG+E</b>	Hot Gas Defrost + Electrical Defrost on drip tray		
<b>BFT</b>	Basic Switch Board + Speed Control Temperature	<b>W</b>	Water Defrost		
<b>BSFP</b>	Basic Switch Board + Speed Control Pres. + Signal	<b>W+E</b>	Water Defrost + Electrical Defrost on drip tray		

Note: valid for the entire product range

# Cubic Plastic

## Product description

### Application

Units designed for use in small and medium cold rooms ranging from 10 to 400m<sup>3</sup>. Models designed for simple and fast maintenance with immediate access to inspection areas. This series is available as a DX evaporator.

### Capacity

Nominal capacity according to ENV328 and EUROVENT rules (SC2): 1.2 - 15kW.

### Standard design

#### Coil

Coil manufactured from corrugated aluminium fins and copper rippled tubes with a nominal diameter of 12mm for DX evaporator.

#### Casing

Manufactured from plastic materials, it is suitable for applications where a high level of hygiene is required or for extremely saline environments like the sea.

### Benefits

Product details:

- Large heat exchanger surface
- Low power consumption fan motor
- Low noise level
- Compact design
- Easy maintenance and access

### Options

- Fan pre-wired to main terminal box
- Drain-pipe flexible electrical heater
- 6-pole, 230V/1ph and 400V/3ph
- 4-pole, 400V/3ph
- Reheating coil
- Pre-coated fins
- Cataphoresis treatment
- Electric defrost



### Fans

- Single-phase motor 230V-50Hz, 4-pole, protection class IP44 according to DIN40050.
- Integrated thermal protection by thermal contacts.
- Reliable protection against overload.

T [°C]	20	10	0	-10	-15	-20	-25	-30
Fc	1	1,04	1,08	1,12	1,14	1,16	1,18	1,2

Models	Capacity* SC2	Capacity* SC3	Airflow	Air Throw	Surface	Tube volume	Defrost	Fan Motors	Motor data	Noise	Connections		Weight
	kW	kW									mm	mm	
	$\Delta T1 = 8K,$ Tev=-8°C	$\Delta T1 = 7K,$ Tev=-25°C	m <sup>3</sup> /h	m	m <sup>2</sup>	dm <sup>3</sup>	W E	n° x Ø mm	220V	dB(A) (5 m)	inlet	outlet	Kg
GL41	1,63	1,31	1450	16	10	1,2	1050	1x300	P= 118W I <sub>n</sub> = 0,56A n= 1430min-1	52	1/2" SAE	12 mm	16
GL42	2,12	1,66	1350	15	13,4	2,1	1050	1x300		52	1/2" SAE	12 mm	18
GL43	3,25	2,63	2900	18	20	2,2	2100	2x300		55	1/2" SAE	16 mm	25
GL44	4,26	3,36	2700	17	26,7	3,5	2100	2x300		55	1/2" SAE	16 mm	30
GL45	6,24	4,94	4551	25	38,2	5,2	2880	2x350	P= 152W I <sub>n</sub> = 0,66A n= 1400min-1	60	1/2" SAE	24 mm	42
GL46	7,39	5,96	4169	24	57,2	7,3	3660	2x350		60	1/2" SAE	24 mm	49
GL47	9,41	7,55	6820	27	57,2	7,1	4340	3x350		62	1/2" SAE	24 mm	59
GL48	11,22	9,04	6261	26	85,9	10,4	5520	3x350		62	1/2" SAE	28 mm	69
GL49	15,55	12,58	8348	28	114,5	14,6	7300	4x350		63	5/8" SAE	28 mm	90
RL51	1,42	1,15	1490	17	7,6	1,2	1050	1x300	P= 118W I <sub>n</sub> = 0,56A n= 1430min-1	52	1/2" SAE	12 mm	15
RL52	1,92	1,51	1409	16	10,2	2,1	1050	1x300		52	1/2" SAE	12 mm	17
RL53	2,84	2,31	2979	19	15,2	2,2	2100	2x300		55	1/2" SAE	16 mm	24
RL54	3,84	3,06	2821	18	20,3	3,5	2100	2x300		55	1/2" SAE	16 mm	29
RL55	5,94	4,75	4780	26	29	5,2	2880	2x350	P= 152W I <sub>n</sub> = 0,66A n= 1400min-1	60	1/2" SAE	24 mm	40
RL56	6,97	5,65	4511	25	43,6	7,3	3660	2x350		60	1/2" SAE	24 mm	47
RL57	8,77	7,08	7163	28	43,6	7,1	4340	3x350		62	1/2" SAE	24 mm	56
RL58	10,49	8,49	6767	27	65,3	10,4	5520	3x350		62	1/2" SAE	28 mm	65
RL59	14,37	11,68	8597	29	87,1	14,6	7300	4x350		63	5/8" SAE	28 mm	86
BL71	1,18	0,96	1510	17	5,5	1,2	1050	1x300	P= 118W I <sub>n</sub> = 0,56A n= 1430min-1	52	1/2" SAE	12 mm	15
BL72	1,76	1,4	1449	16	7,3	2,1	1050	1x300		52	1/2" SAE	12 mm	17
BL73	2,41	1,97	3021	19	11	2,2	2100	2x300		55	1/2" SAE	16 mm	24
BL74	3,48	2,79	2901	18	14,7	3,5	2100	2x300		55	1/2" SAE	16 mm	29
BL75	5,25	4,22	4891	27	21	5,2	2880	2x350	P= 152W I <sub>n</sub> = 0,66A n= 1400min-1	60	1/2" SAE	24 mm	40
BL76	6,45	5,25	4662	26	31,5	7,3	3660	2x350		60	1/2" SAE	24 mm	47
BL77	8,23	6,69	7328	29	31,5	7,1	4340	3x350		62	1/2" SAE	24 mm	56
BL78	9,72	7,79	6992	28	47,2	10,4	5520	3x350		62	1/2" SAE	28 mm	65
BL79	12,2	9,81	8763	30	62,9	14,6	7300	4x350		63	5/8" SAE	28 mm	86

Nominal capacity according to ENV 328 and Eurovent regulations (refrigerant R404A,  $\Delta T1 = T_{in} \text{ air} - T_{ev}$ ). Use external equalised thermostatic expansion valve.

# Cubic Plastic

## Drawings

Models	Dimensions			
	A	B	C	D
	mm	mm	mm	mm
GL41/RL51/BL71	810	430	530	250
GL42/RL52/BL72	810	430	530	250
GL43/RL53/BL73	1310	430	1030	250
GL44/RL54/BL74	1310	430	1030	250
GL45/RL55/BL75	1310	550	1030	300
GL46/RL56/BL76	1310	550	1030	300
GL47/RL57/BL77	1810	550	1530	300
GL48/RL58/BL78	1810	550	1530	300
GL49/RL59/BL79	2310	550	2030	300

We reserve the right to change our technical data without prior notice.

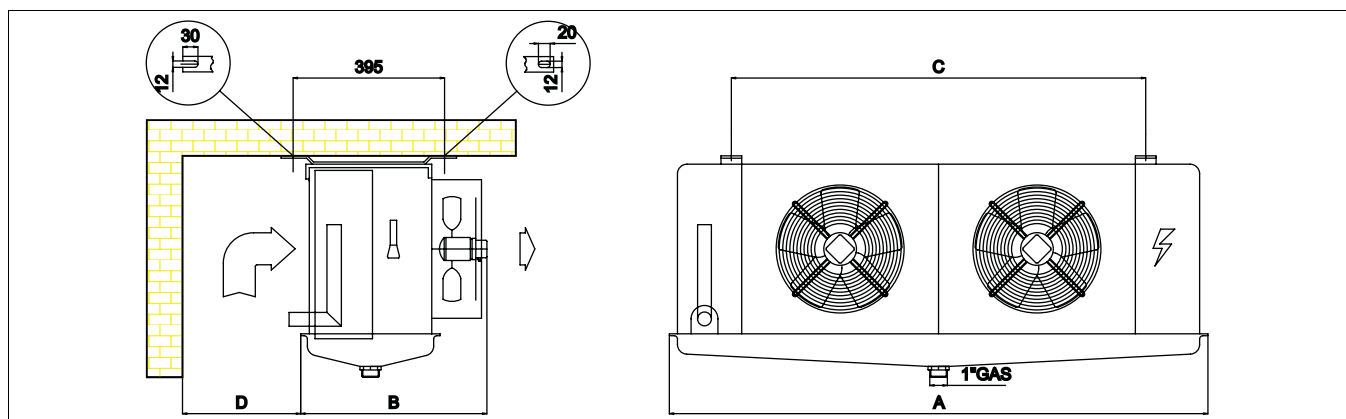

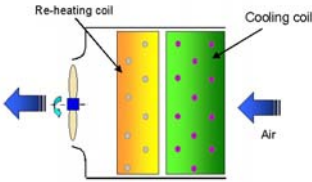
<h1>Cubic Plastic</h1>		
<h2>Options</h2>		
<b>Fan pre-wired to main terminal box</b>		
	Fan motor pre-wired to main terminal junction box IP55, in painted galvanized steel. See Electrical Data page.	<b>Model:</b> All Models
<b>Fan motors</b>		
	6-pole, 230V/1Ph 4-pole, 230-400V/3Ph	<b>Model:</b> For diameter: 300mm 350mm
<b>Cable electric heater</b>		
	Applications: We recommend that you heat the drain pipeline while defrosting to prevent ice forming in the pipes. The flexible electric heater can easily be placed inside the pipe. Power: 70W. Voltage: 230V	<b>Model:</b> All Models
<b>Reheating coil</b>		
	A separate coil (2 rows) for dehumidifying the airflow rate.	<b>Model:</b> GL41/RL51/BL71 GL42/RL52/BL72 GL43/RL53/BL73 GL44/RL54/BL74 GL45/RL55/BL75 GL46/RL56/BL76 GL47/RL57/BL77 GL48/RL58/BL78 GL49/RL59/BL79
<b>Coil Treatment / Material</b>		
	<b>Pre-coated fins:</b> Epoxy-coated, pre-painted aluminium fins. <b>Cataphoresis treatment:</b> An electrolytic process is achieved by submerging the coil in a paint bath, where it acts as a cathode and gets completely coated in an epoxy paint, which gives exceptional protection against corrosion. Recommended for alkaline or saline atmospheres.	<b>Model:</b> <b>ALL APPLICATIONS</b> All Models

# Cubic Plastic

## Electrical Data

### Junction box for motors

Series GL/RL/BL

Function

Junction box complete with screw-on cover, cable glands and terminal strip.

#### General data

Material: Plastic

IP Protection Class: Min IP55

Colour: Grey RAL7035

Insulation class: II

Ambient Temp.: -25°C Max +50°C

Weight: 0,5 kg

#### Dimensions

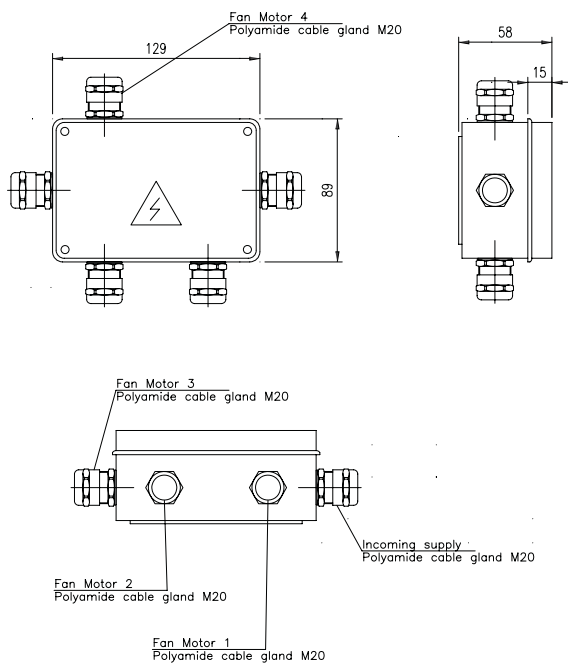

#### Electric wiring diagram

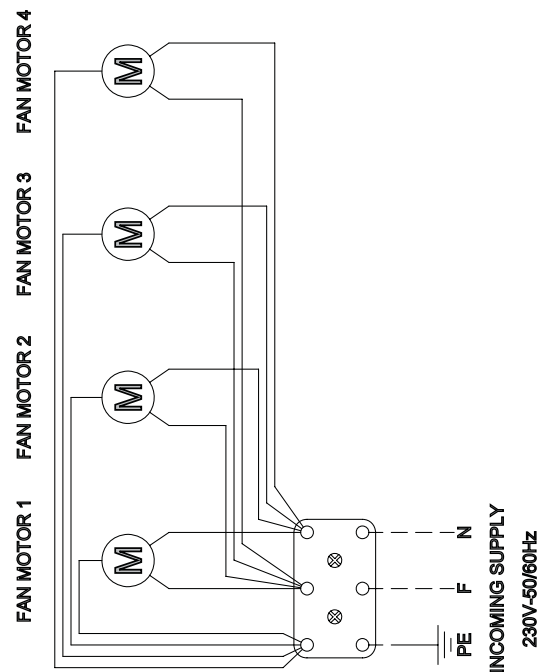



**Junction box for "E" defrost**

**Series GL/RL/BL**

**Function**

Junction box complete with screw-on cover, cable glands and terminal strip.

**General data**

Material: Plastic  
 IP Protection Class: Min IP55  
 Colour: Grey RAL7035  
 Insulation class: II  
 Ambient Temp.: -25°C Max +50°C  
 Weight: 0,5 kg

**Dimensions** **Electric wiring diagram**

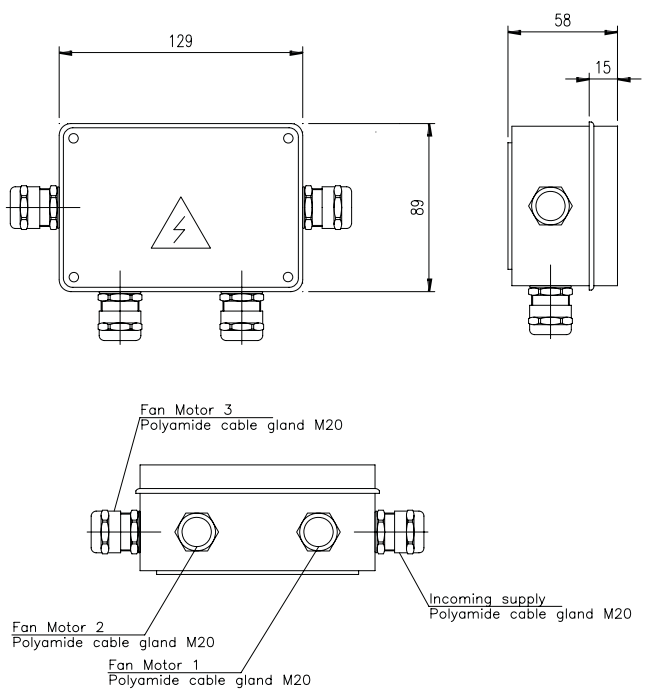

**NOTE:**  
 (1) N° OF MOUNTED CABLE IS ACCORDING TO ORDER

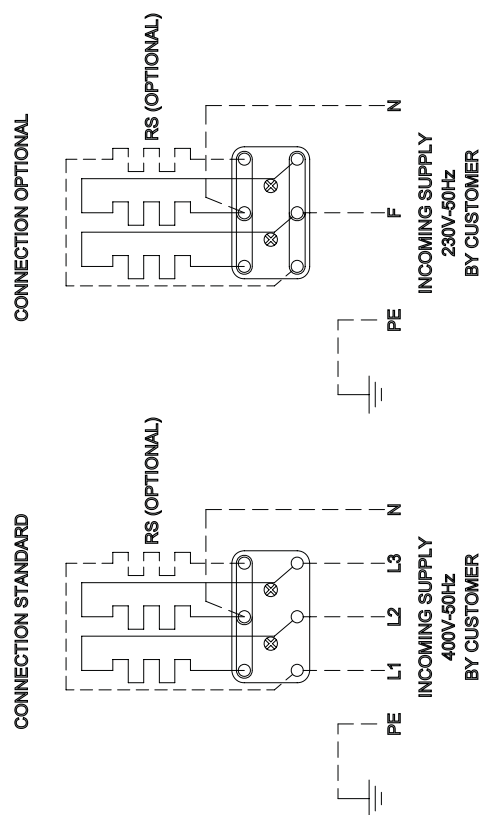

# Cubic Plastic

## Code description

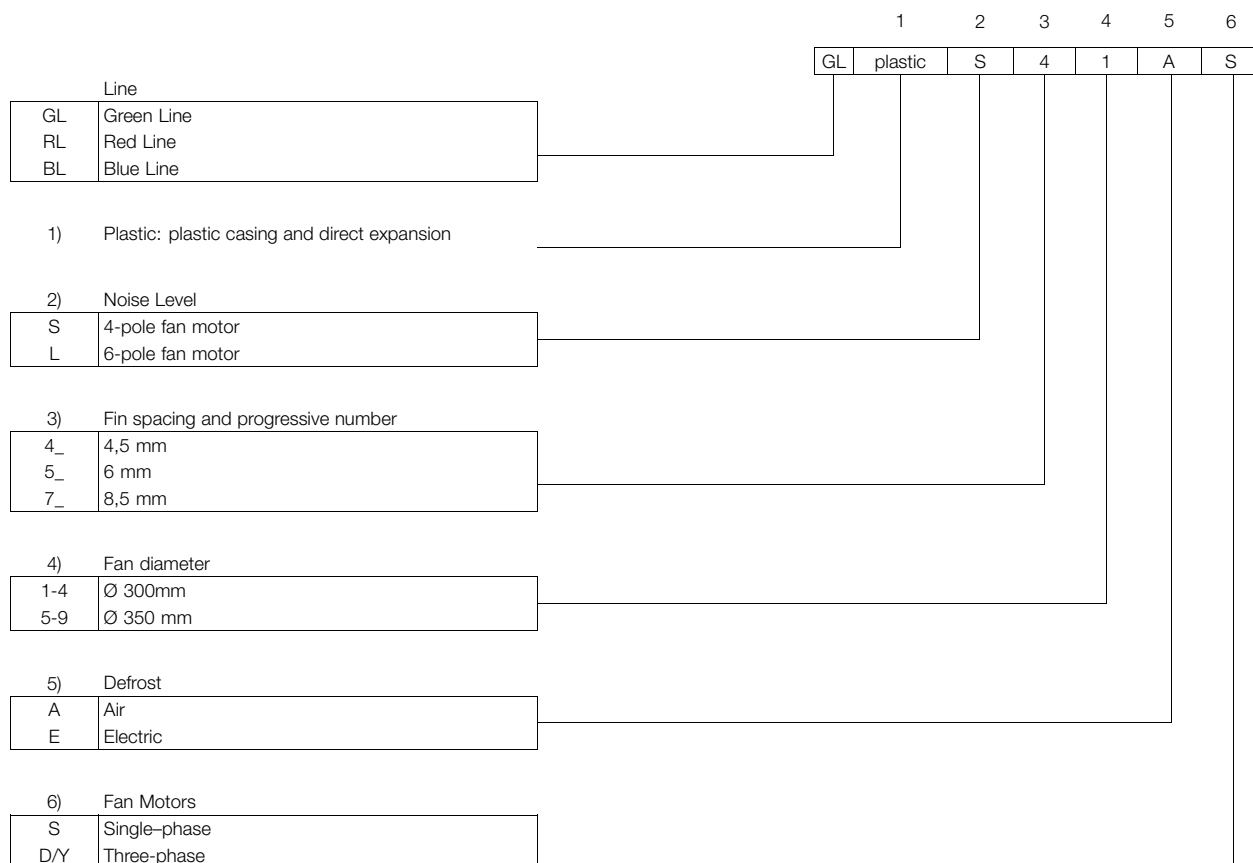

General Alfa Select Air Legend

		Description 1		Description 2	
<b>D</b>	D fan cabling (three phase)	<b>BSFT</b>	Basic Switch Board + Speed Control Temp. + Signal	<b>AL</b>	Aluminium fin
<b>Y</b>	Y fan cabling (three phase)	<b>BI</b>	Basic Switch Board + Frequency Converter (Inverter)	<b>CU</b>	Copper fin
<b>D/Y</b>	D/Y fan cabling (three phase), single speed fan motor	<b>BSI</b>	Basic Switch Board + Frequency Converter (Inverter) + Signal	<b>PR</b>	Pre-coated fin
<b>S</b>	Single phase	<b>C</b>	Switch Board + Cooling fan	<b>SS</b>	Stainless steel tube
<b>P</b>	Packaged on a pallet	<b>R</b>	Switch Board + Resistor	<b>TH</b>	Thermoguard treatment
<b>CR</b>	Packaged in a crate	<b>F</b>	Switch Board + Cooling fan + Resistor	<b>CF</b>	Cataphoresis treatment
<b>BO</b>	Packaged in a box	<b>PT</b>	Ammonia pump top	<b>SC</b>	Sub-cooling circuit
<b>Feet</b>	Feet-mounted	<b>PB</b>	Ammonia pump bottom	<b>KW</b>	Spray water kit
<b>SW</b>	Safety Switch	<b>AL</b>	Aluminium casing	<b>FL</b>	Flanges
<b>CB</b>	Terminal Box	<b>SS</b>	Stainless Steel casing	<b>FH</b>	Fan ring heater
<b>B</b>	Basic Switch Board	<b>AP</b>	Pre-painted Aluminium casing	<b>IS</b>	Insulated Drip Tray
<b>BS</b>	Basic Switch Board + Signal	<b>PL</b>	Plastic casing	<b>RH</b>	Reheating coil
<b>BP</b>	Basic Switch Board + Step Control Pressure	<b>E</b>	Electrical defrost	<b>SR</b>	Air socket adapter ring
<b>BT</b>	Basic Switch Board + Step Control Temperature	<b>LE</b>	Low Electrical defrost	<b>CW</b>	Air throw fan cowling
<b>BSP</b>	Basic Switch Board + Step Control Pressure + Signal	<b>A</b>	Air Defrost	<b>ER</b>	120° elbow reducer
<b>BST</b>	Basic Switch Board + Step Control Temp. + Signal	<b>HG</b>	Hot Gas Defrost	<b>HN</b>	Hinged fan cowling
<b>BFP</b>	Basic Switch Board + Speed Control Pressure	<b>HG+E</b>	Hot Gas Defrost + Electrical Defrost on drip tray		
<b>BFT</b>	Basic Switch Board + Speed Control Temperature	<b>W</b>	Water Defrost		
<b>BSFP</b>	Basic Switch Board + Speed Control Pres. + Signal	<b>W+E</b>	Water Defrost + Electrical Defrost on drip tray		

Note: valid for the entire product range

## AirMax II DX/W

### Product Description

#### Applications

This new range of industrial unit coolers has been designed using the well-known Airmax technology, which has become a standard for all installers and end users.

Airmax II is available as a direct expansion evaporator (DX) for all HFCs as well as water/glycol unit coolers. This new industrial line is designed to keep fresh and frozen goods refrigerated from +30 to -40°C, with a high or low humidity content.

Thanks to a wide capacity range (from 5 to 180 kW), which can be achieved using several coil combinations, fan diameters (up to 800mm), different fin spacing and a long list of options, Alfa Laval can fulfil every requirement with more than 200 standard models.

#### Standard design

##### Coil

The heat exchanger is designed to achieve optimal capacity thanks to the staggered pitch rows that give a high secondary fin surface. The large fin surface ensures longer intervals between defrost cycles, therefore reducing the amount of daily energy used. The coils are manufactured with a special aluminium fin array and have a high efficiency internal copper tube with a grooved inner wall with 12 mm nominal bore. All this allows for a minimal internal volume with the advantage of using less refrigerant.

##### Water/glycol

For water/glycol applications, the coil is designed with same fin pattern and smooth 5/8" copper tube. All connections are thread connections with vent and drain plug as standard.

All other characteristics are the same as for the Airmax II DX.

##### Casing

All units are manufactured using galvanised steel, zinc-coated and finished in corrosive-resistant RAL, except the drip tray which is aluminium coated.

The frame has been designed to ensure easy installation and maintenance. A large, deep drip tray allows fast discharge of defrost water and the hinge fastening allows for easy maintenance. The supports have two different positions (ceiling or space) to enable installation of the water defrost cassette.

Structural parts are fastened with stainless steel bolts and screws. Structures are made in galvanised steel with optimised length to enable uniform air suction in the coil.

All panels such as the drip tray end covers are hinged for easier accessibility, making installation, servicing and maintenance easier than for other standard unit coolers.

#### Benefits

- Low installation costs
- Reliable performance
- Long air throw
- Designed for all working conditions



- Uniform distribution throughout the cold room
- Corrosion resistance by powder coating
- Plug-in installation
- Easy to clean, long service life
- Eurovent certified

#### Options

- Electric defrost
- Light electric defrost
- Hot Gas defrost, coil and drip tray (DX only)
- Water defrost (suggested for TC above -5°C)
- Combined defrost systems
- Drip tray insulation (not combined with electric defrost)
- Alfastreamer (only for 500/630/800mm fans)
- Air sock adapter ring
- Fan ring heater
- Supply voltage 230V-1ph-50Hz (500mm only)
- 50 or 60 Hz for all models
- Wired fan motors
- Switch on/off single fan motor
- Stainless steel 304 casing including drip tray
- Stainless steel 304 drip tray only
- Floor mounting supports
- Epoxy pre-coated fins

- Cataphoresis coil treatment

### Fans

Air suction fans are available in four different fan diameters: 500, 560, 630 and 800 mm, with a 2-speed, three-phase motor ( $\Delta/\gamma$ ) 400V 50Hz. The motors have a dynamically and statically balanced external rotor and are manufactured in accordance with VDE 0530/12.84 IP54 class F.

Integrated thermo contacts (Clikson), provide reliable protection against thermal overload.

All standard motors can work at temperatures down to  $-40^{\circ}\text{C}$ . Special lubrication is available on request.

R&D has developed the air flow distribution in order to give a uniform air velocity in the coil with:

- High efficiency sickle blade
- Better distribution in cold rooms
- Reduced noise levels
- Increased air throw

<b>T [°C]</b>	20	10	0	-10	-15	-20	-25	-30
<b>Fc</b>	1	1,04	1,08	1,12	1,14	1,16	1,18	1,2

### Test

Each DX heat exchanger undergoes a pressure and leak test with dry air at 31 bar, and is finally supplied with a nitrogen pre-charge, while the water/glycol is tested at 11 bar.

Model	Capacity*		Air Flow	Air Throw		Sur-face	Tube volume	Defrost					Fan Motors n°x ø	Fan Motors	Noise	Connections		Weight	
	[SC2]	[SC3]		-	Alfa Streamer			m <sup>2</sup>	dm <sup>3</sup>	E	EL	HG+E			FRH	W	dB(A)		mm
	kW	kW	m <sup>3</sup> /h	m			W	W	W	W	l/h	kPa	mm	(5m)	inlet	outlet	Kg		
<b>4mm Fin Spacing / High Speed Rotation</b>																			
ILGE501A4	9.1	7.4	7966	35	70	56	6	4200	2100	1400	450	1500	5	1 x 500	P=790W I=1.45A n=1330min-1 V=400V 4 poles	64	16	28	90
ILGE501C4	12.2	9.3	7628	34	67	85	8	6300	2800	1400	450	2300	5	1 x 500		64	16	28	95
ILGE501E4	14.2	10.8	7294	32	65	113	11	8400	4200	1400	450	3000	5	1 x 500		64	16	35	100
ILGE502A4	18.2	13.6	15894	38	76	111	11	8400	4200	2800	900	3000	7	2 x 500		67	16	35	185
ILGE502C4	24.1	18.3	15197	37	74	166	17	12600	5600	2800	900	4500	7	2 x 500		67	22	42	195
ILGE502E4	28.3	21.8	14511	36	71	222	22	16800	8400	2800	900	5900	7	2 x 500		67	22	54	205
ILGE503A4	27.6	21.1	23820	40	80	165	17	12600	6300	4200	1350	4500	8	3 x 500		69	22	42	272
ILGE503C4	36.3	28.2	22764	39	78	248	25	18900	8400	4200	1350	6800	8	3 x 500		69	28	54	289
ILGE503E4	41.6	31.1	21727	38	75	331	33	25200	12600	4200	1350	8900	8	3 x 500		69	28	54	303
ILGE504A4	35.6	25.3	31747	42	83	220	22	16200	8100	5400	1800	6000	9	4 x 500		70	22	54	364
ILGE504C4	47.2	34.6	30331	40	81	330	33	24300	10800	5400	1800	9000	9	4 x 500	70	28	54	383	
ILGE504E4	55.5	41.5	28942	39	78	440	44	32400	16200	5400	1800	12000	9	4 x 500	70	28	64	403	
ILGE505A4	45.7	34.3	39673	43	85	274	27	20400	10200	6800	2250	7500	10	5 x 500	71	28	54	454	
ILGE505C4	60.2	46.0	37898	41	83	411	41	30600	13600	6800	2250	11300	10	5 x 500	71	28	64	478	
ILGE505E4	70.6	54.8	36158	40	80	549	55	40800	20400	6800	2250	15000	10	5 x 500	71	35	76	503	
ILGE561C4	17.8	12.9	11060	42	-	132	13	9600	4800	1600	500	3500	8	1 x 560	P=1000W I=1.8A n=1220min-1 V=400V 4 poles	68	16	35	120
ILGE561E4	20.8	15.5	10563	41	-	176	18	12000	5600	1600	500	4700	8	1 x 560		68	22	42	128
ILGE561G4	23.0	17.3	10095	39	-	220	22	14400	7200	1600	500	6000	8	1 x 560		68	28	42	144
ILGE562C4	35.7	26.3	22043	46	-	260	26	19200	9600	3200	1000	7100	10	2 x 560		71	28	54	282
ILGE562E4	41.8	31.4	21028	45	-	347	35	24000	11200	3200	1000	9500	10	2 x 560		71	35	54	298
ILGE562G4	45.9	35.1	20077	43	-	434	43	28800	14400	3200	1000	11500	10	2 x 560		71	35	64	330
ILGE563C4	54.3	41.2	33025	48	-	388	39	28800	14400	4800	1500	10600	12	3 x 560		73	35	64	377
ILGE563E4	64.0	49.9	31492	47	-	518	52	36000	18000	4800	1500	14000	12	3 x 560		73	35	76	403
ILGE563G4	69.4	54.1	30059	45	-	647	65	43200	21600	4800	1500	17500	12	3 x 560		73	42	76	451
ILGE564C4	72.9	56.7	44007	50	-	516	52	38400	19200	6400	2000	14200	15	4 x 560		74	42	76	523
ILGE564E4	84.9	66.7	41957	48	-	689	69	48000	22400	6400	2000	18500	15	4 x 560	74	42	76	556	
ILGE564G4	92.7	73.6	40040	47	-	861	86	57600	28800	6400	2000	23000	15	4 x 560	74	42	89	619	
ILGE565C4	89.5	66.5	54989	51	-	645	65	48000	24000	8000	2500	17700	21	5 x 560	75	42	76	598	
ILGE565E4	104.5	79.2	52421	50	-	859	86	60000	28000	8000	2500	23000	21	5 x 560	75	42	89	638	
ILGE565G4	114.8	88.3	50021	48	-	1074	108	72000	36000	8000	2500	29000	21	5 x 560	75	42	89	719	
ILGE631C4	25.5	19.6	17289	57	115	165	17	9600	5600	1600	550	4500	12	1 x 630	P=2600W I=4.8A n=1310min-1 V=400V 4 poles	75	28	42	177
ILGE631E4	29.4	21.4	16728	56	112	220	22	14400	7200	1600	550	6000	12	1 x 630		75	28	54	187
ILGE631G4	33.9	26.2	16160	54	108	275	28	16800	8800	1600	550	7500	12	1 x 630		75	35	54	207
ILGE632C4	49.5	35.7	34495	62	123	325	33	19200	11200	3200	1100	8900	15	2 x 630		78	35	64	365
ILGE632E4	59.2	43.7	33342	60	120	434	43	28800	14400	3200	1100	11500	15	2 x 630		78	35	76	385
ILGE632G4	66.3	49.8	32179	58	117	542	54	33600	17600	3200	1100	14500	15	2 x 630		78	35	76	426
ILGE633C4	75.5	56.3	51701	64	128	485	49	28800	16800	4800	1650	13300	20	3 x 630		80	35	76	547
ILGE633E4	90.0	68.3	49954	62	125	647	65	43200	21600	4800	1650	17500	20	3 x 630		80	42	76	576
ILGE633G4	101.7	79.3	48197	61	122	809	81	50400	26400	4800	1650	22000	20	3 x 630		80	42	89	638
ILGE634C4	101.6	78.0	68905	66	132	646	65	38400	22400	6400	2200	17700	25	4 x 630		81	42	89	722
ILGE634E4	121.0	94.1	66566	64	129	861	86	57600	28800	6400	2200	23000	25	4 x 630	81	42	89	762	
ILGE634G4	135.1	106.1	64214	63	125	1076	108	67200	35200	6400	2200	29000	25	4 x 630	81	2 x 42	2 x 76	844	
ILGE635C4	124.1	90.0	86110	67	135	806	81	48000	28000	8000	2750	22100	30	5 x 630	82	42	89	882	
ILGE635E4	148.4	110.4	83178	66	131	1074	108	72000	36000	8000	2750	29000	30	5 x 630	82	2 x 35	2 x 76	932	
ILGE635G4	166.0	125.5	80231	64	128	1343	135	84000	44000	8000	2750	36000	30	5 x 630	82	2 x 42	2 x 76	1033	
ILGE801C4	39.3	28.5	30394	79	-	236	24	18000	9000	3000	700	6500	15	1 x 800	P=5100W I=8.8A n=1270min-1 V=400V 4 poles	81	28	54	257
ILGE801E4	46.7	33.9	28969	75	-	315	32	21000	12000	3000	700	8500	15	1 x 800		81	35	64	271
ILGE801G4	53.2	39.9	27687	72	-	394	39	21000	12000	3000	700	10500	15	1 x 800		81	35	64	300
ILGE802C4	80.3	62.0	60599	84	-	467	47	34200	17100	5700	1400	12800	25	2 x 800		84	42	76	530
ILGE802E4	96.0	74.9	57712	81	-	623	62	39900	22800	5700	1400	16500	25	2 x 800		84	2 x 35	2 x 64	558
ILGE802G4	107.6	84.8	55122	78	-	779	78	39900	22800	5700	1400	21000	25	2 x 800		84	2 x 35	2 x 64	617
ILGE803C4	120.4	93.0	90803	87	-	698	70	52200	26100	8700	2100	19100	30	3 x 800		86	2 x 35	2 x 64	793
ILGE803E4	143.9	112.6	86453	84	-	930	93	60900	34800	8700	2100	25000	30	3 x 800		86	2 x 42	2 x 76	836
ILGE803G4	161.3	127.2	82555	81	-	1163	116	60900	34800	8700	2100	31000	30	3 x 800		86	2 x 42	2 x 76	925
ILGE804C4	156.5	112.2	121006	89	-	928	93	70200	35100	11700	2800	25500	40	4 x 800		87	2 x 35	2 x 76	1046
ILGE804E4	188.1	138.9	115194	86	-	1238	124	81900	46800	11700	2800	33500	40	4 x 800	87	2 x 42	2 x 89	1105	
ILGE804G4	211.5	158.5	109987	83	-	1547	155	81900	46800	11700	2800	41500	40	4 x 800	87	2 x 42	2 x 89	1223	

Model	Capacity*		Air Flow	Air Throw		Sur-face	Tube volume	Defrost					Fan Motors n°x ø	Fan Motors	Noise	Connections		Weight	
	[SC2]	[SC3]		-	Alfa Streamer			E	EL	HG+E	FRH	W				dB(A)	mm		
	kW	kW	m³/h	m	m²	dm³	W	W	W	W	l/h	kPa	mm	(5m)	inlet	outlet	Kg		
<b>6mm Fin Spacing / High Speed Rotation</b>																			
ILRE501A6	7.1	5.7	8100	35	71	38	6	4200	2100	1400	450	1500	5	1 x 500	P=790W I=1.45A n=1330min-1 V=400V 4 poles	64	16	28	88
ILRE501C6	9.9	7.8	7837	34	69	58	8	6300	2800	1400	450	2300	5	1 x 500		64	16	28	93
ILRE501E6	12.0	9.3	7567	33	67	77	11	8400	4200	1400	450	3000	5	1 x 500		64	16	35	98
ILRE502A6	14.5	11.1	16169	39	77	75	11	8400	4200	2800	900	3000	7	2 x 500		67	16	35	181
ILRE502C6	19.8	15.3	15626	38	75	113	17	12600	5600	2800	900	4500	7	2 x 500		67	22	42	191
ILRE502E6	23.9	18.7	15070	37	73	151	22	16800	8400	2800	900	5900	7	2 x 500		67	22	54	201
ILRE503A6	21.7	17.0	24239	41	81	112	17	12600	6300	4200	1350	4500	8	3 x 500		69	22	42	267
ILRE503C6	29.5	23.3	23415	40	79	169	25	18900	8400	4200	1350	6800	8	3 x 500		69	28	54	283
ILRE503E6	35.6	27.1	22572	39	77	225	33	25200	12600	4200	1350	8900	8	3 x 500		69	28	54	297
ILRE504A6	28.7	21.4	32308	42	84	149	22	16200	8100	5400	1800	6000	9	4 x 500		70	22	54	357
ILRE504C6	39.2	29.6	31203	41	82	224	33	24300	10800	5400	1800	9000	9	4 x 500	70	28	54	376	
ILRE504E6	47.5	36.2	30074	40	80	299	44	32400	16200	5400	1800	12000	9	4 x 500	70	28	64	395	
ILRE505A6	36.3	28.0	40377	43	87	186	27	20400	10200	6800	2250	7500	10	5 x 500	71	28	54	445	
ILRE505C6	49.4	38.4	38991	42	84	280	41	30600	13600	6800	2250	11300	10	5 x 500	71	28	64	468	
ILRE505E6	59.5	46.9	37576	41	82	373	55	40800	20400	6800	2250	15000	10	5 x 500	71	35	76	493	
ILRE561C6	14.9	11.1	11371	44	-	90	13	9600	4800	1600	500	3500	8	1 x 560	P=1000W I=1.8A n=1220min-1 V=400V 4 poles	68	16	35	118
ILRE561E6	18.0	13.6	10968	42	-	120	18	12000	5600	1600	500	4700	8	1 x 560		68	22	42	125
ILRE561G6	20.3	15.6	10574	41	-	150	22	14400	7200	1600	500	6000	8	1 x 560		68	28	42	141
ILRE562C6	29.8	22.5	22681	47	-	177	26	19200	9600	3200	1000	7100	10	2 x 560		71	28	54	276
ILRE562E6	35.9	27.5	21855	46	-	236	35	24000	11200	3200	1000	9500	10	2 x 560		71	35	54	292
ILRE562G6	40.5	31.3	21051	45	-	295	43	28800	14400	3200	1000	11500	10	2 x 560		71	35	64	323
ILRE563C6	44.8	34.7	33991	50	-	264	39	28800	14400	4800	1500	10600	12	3 x 560		73	35	64	370
ILRE563E6	54.2	42.8	32742	48	-	352	52	36000	16800	4800	1500	14000	12	3 x 560		73	35	76	395
ILRE563G6	60.7	47.9	31527	47	-	440	65	43200	21600	4800	1500	17500	12	3 x 560		73	42	76	442
ILRE564C6	59.6	47.0	45300	51	-	351	52	38400	19200	6400	2000	14200	15	4 x 560		74	42	76	512
ILRE564E6	71.6	57.0	43628	50	-	468	69	48000	22400	6400	2000	18500	15	4 x 560	74	42	76	544	
ILRE564G6	80.6	64.6	42003	48	-	585	86	57600	28800	6400	2000	23000	15	4 x 560	74	42	89	607	
ILRE565C6	74.4	56.7	56610	52	-	438	65	48000	24000	8000	2500	17700	21	5 x 560	75	42	76	586	
ILRE565E6	89.6	69.1	54514	51	-	584	86	60000	28000	8000	2500	23000	21	5 x 560	75	42	89	625	
ILRE565G6	101.0	78.7	52478	50	-	730	108	72000	36000	8000	2500	29000	21	5 x 560	75	42	89	705	
ILRE631C6	20.7	16.2	17615	58	117	112	17	9600	5600	1600	550	4500	12	1 x 630	P=2600W I=4.8A n=1310min-1 V400V 4 poles	75	28	42	173
ILRE631E6	25.0	18.7	17189	57	114	150	22	14400	7200	1600	550	6000	12	1 x 630		75	28	54	183
ILRE631G6	29.1	22.8	16741	56	112	187	28	16800	8800	1600	550	7500	12	1 x 630		75	35	54	203
ILRE632C6	40.8	30.5	35168	63	125	221	33	19200	11200	3200	1100	8900	15	2 x 630		78	35	64	358
ILRE632E6	50.0	37.9	34290	61	123	295	43	28800	14400	3200	1100	11500	15	2 x 630		78	35	76	377
ILRE632G6	57.6	44.0	33369	60	120	368	54	33600	17600	3200	1100	14500	15	2 x 630		78	35	76	417
ILRE633C6	61.7	47.3	52720	65	130	330	49	28800	16800	4800	1650	13300	20	3 x 630		80	35	76	536
ILRE633E6	75.6	58.4	51389	64	128	440	65	43200	21600	4800	1650	17500	20	3 x 630		80	42	76	565
ILRE633G6	87.2	68.8	49995	63	125	550	81	50400	26400	4800	1650	22000	20	3 x 630		80	42	89	625
ILRE634C6	82.3	64.4	70271	67	134	439	65	38400	22400	6400	2200	17700	25	4 x 630		81	42	89	707
ILRE634E6	100.5	79.4	68488	66	131	585	86	57600	28800	6400	2200	23000	25	4 x 630	81	42	89	747	
ILRE634G6	115.2	91.5	66621	64	129	731	108	67200	35200	6400	2200	29000	25	4 x 630	81	2 x 42	2 x 76	827	
ILRE635C6	102.1	76.8	87823	68	137	548	81	48000	28000	8000	2750	22100	30	5 x 630	82	42	89	865	
ILRE635E6	125.1	95.5	85586	67	134	730	108	72000	36000	8000	2750	29000	30	5 x 630	82	2 x 35	2 x 76	913	
ILRE635G6	143.9	110.6	83246	66	131	913	135	84000	44000	8000	2750	36000	30	5 x 630	82	2 x 42	2 x 76	1012	
ILRE801C6	32.3	24.2	31343	81	-	161	24	18000	9000	3000	700	6500	15	1 x 800	P=5100W I=8.8A n=1270min-1 V=400V 4 poles	81	28	54	252
ILRE801E6	39.5	29.6	30124	78	-	214	32	21000	12000	3000	700	8500	15	1 x 800		81	35	64	266
ILRE801G6	45.8	35.1	29000	75	-	268	39	21000	12000	3000	700	10500	15	1 x 800		81	35	64	294
ILRE802C6	64.6	50.8	62528	86	-	318	47	34200	17100	5700	1400	12800	25	2 x 800		84	42	76	519
ILRE802E6	79.2	62.7	60052	83	-	423	62	39900	22800	5700	1400	16500	25	2 x 800		84	2 x 35	2 x 64	547
ILRE802G6	90.9	72.5	57775	81	-	529	78	39900	22800	5700	1400	21000	25	2 x 800		84	2 x 35	2 x 64	605
ILRE803C6	96.9	76.3	93710	89	-	474	70	52200	26100	8700	2100	19100	30	3 x 800		86	2 x 35	2 x 64	777
ILRE803E6	118.5	94.1	89978	87	-	632	93	60900	34800	8700	2100	25000	30	3 x 800		86	2 x 42	2 x 76	819
ILRE803G6	136.3	108.8	86549	84	-	791	116	60900	34800	8700	2100	31000	30	3 x 800		86	2 x 42	2 x 76	907
ILRE804C6	128.7	96.0	124893	92	-	631	93	70200	35100	11700	2800	25500	40	4 x 800		87	2 x 35	2 x 76	1025
ILRE804E6	158.1	120.0	119904	89	-	841	124	81900	46800	11700	2800	33500	40	4 x 800	87	2 x 42	2 x 89	1083	
ILRE804G6	182.2	139.4	115322	86	-	1052	155	81900	46800	11700	2800	41500	40	4 x 800	87	2 x 42	2 x 89	1199	

Model	Capacity*		Air Flow	Air Throw		Sur-face	Tube volume	Defrost					Fan Motors n°x ø	Fan Motors	Noise	Connections		Weight	
	[SC2]	[SC3]		-	Alfa Streamer			m²	dm³	E	EL	HG+E				FRH	W		dB(A)
	kW	kW	m³/h	m	m	m	W	W	W	W	l/h	kPa	mm	(5m)	inlet	outlet	Kg		
<b>8mm Fin Spacing / High Speed Rotation</b>																			
ILBE501A8	6.3	5.2	8165	36	71	29	6	4200	2100	1400	450	1500	5	1 x 500	P=790W I=1.45A n=1330min-1 V=400V 4 poles	64	16	28	85
ILBE501C8	9.1	7.1	7942	35	69	44	8	6300	2800	1400	450	2300	5	1 x 500		64	16	28	90
ILBE501E8	11.1	8.7	7709	34	68	59	11	8400	4200	1400	450	3000	5	1 x 500		64	16	35	95
ILBE502A8	13.2	10.2	16305	39	78	58	11	8400	4200	2800	900	3000	7	2 x 500		67	16	35	175
ILBE502C8	18.1	14.1	15843	38	76	86	17	12600	5600	2800	900	4500	7	2 x 500		67	22	42	185
ILBE502E8	22.1	17.4	15362	37	74	115	22	16800	8400	2800	900	5900	7	2 x 500		67	22	54	193
ILBE503A8	19.6	15.5	24444	41	82	86	17	12600	6300	4200	1350	4500	8	3 x 500		69	22	42	257
ILBE503C8	26.9	21.4	23744	40	80	129	25	18900	8400	4200	1350	6800	8	3 x 500		69	28	54	273
ILBE503E8	33.1	25.4	23014	39	78	172	33	25200	12600	4200	1350	8900	8	3 x 500		69	28	54	287
ILBE504A8	26.2	19.7	32584	42	85	114	22	16200	8100	5400	1800	6000	9	4 x 500		70	22	54	344
ILBE504C8	36.1	27.5	31645	42	83	171	33	24300	10800	5400	1800	9000	9	4 x 500	70	28	54	362	
ILBE504E8	44.2	34.0	30666	41	81	228	44	32400	16200	5400	1800	12000	9	4 x 500	70	28	64	381	
ILBE505A8	32.8	25.6	40723	44	87	142	27	20400	10200	6800	2250	7500	10	5 x 500	71	28	54	429	
ILBE505C8	45.2	35.4	39545	43	85	214	41	30600	13600	6800	2250	11300	10	5 x 500	71	28	64	451	
ILBE505E8	55.0	43.6	38318	42	83	285	55	40800	20400	6800	2250	15000	10	5 x 500	71	35	76	475	
ILBE561C8	13.7	10.4	11529	44	-	69	13	9600	4800	1600	500	3500	8	1 x 560	P=1000W I=1.8A n=1220min-1 V=400V 4 poles	68	16	35	113
ILBE561E8	16.7	12.8	11179	43	-	91	18	12000	5600	1600	500	4700	8	1 x 560		68	22	42	121
ILBE561G8	19.1	14.7	10831	42	-	114	22	14400	7200	1600	500	6000	8	1 x 560		68	28	42	136
ILBE562C8	27.4	20.9	23005	48	-	135	26	19200	9600	3200	1000	7100	10	2 x 560		71	28	54	266
ILBE562E8	33.4	25.7	22288	47	-	180	35	24000	11200	3200	1000	9500	10	2 x 560		71	35	54	282
ILBE562G8	38.0	29.6	21575	45	-	225	43	28800	14400	3200	1000	11500	10	2 x 560		71	35	64	312
ILBE563C8	41.1	32.0	34481	50	-	202	39	28800	14400	4800	1500	10600	12	3 x 560		73	35	64	357
ILBE563E8	50.1	39.8	33396	49	-	269	52	36000	16800	4800	1500	14000	12	3 x 560		73	35	76	380
ILBE563G8	56.9	45.1	32318	48	-	336	65	43200	21600	4800	1500	17500	12	3 x 560		73	42	76	426
ILBE564C8	54.4	43.2	45957	52	-	268	52	38400	19200	6400	2000	14200	15	4 x 560		74	42	76	494
ILBE564E8	66.1	52.8	44503	50	-	358	69	48000	22400	6400	2000	18500	15	4 x 560	74	42	76	525	
ILBE564G8	75.2	60.4	43061	49	-	447	86	57600	28800	6400	2000	23000	15	4 x 560	74	42	89	585	
ILBE565C8	68.4	52.6	57432	53	-	335	65	48000	24000	8000	2500	17700	21	5 x 560	75	42	76	565	
ILBE565E8	83.2	64.6	55611	52	-	446	86	60000	28000	8000	2500	23000	21	5 x 560	75	42	89	603	
ILBE565G8	94.9	74.3	53803	51	-	558	108	72000	36000	8000	2500	29000	21	5 x 560	75	42	89	680	
ILBE631C8	18.8	14.9	17771	59	118	86	17	9600	5600	1600	550	4500	12	1 x 630	P=2600W I=4.8A n=1310min-1 V=400V 4 poles	75	28	42	167
ILBE631E8	23.3	17.6	17417	58	116	114	22	14400	7200	1600	550	6000	12	1 x 630		75	28	54	177
ILBE631G8	27.1	21.3	17037	57	113	143	28	16800	8800	1600	550	7500	12	1 x 630		75	35	54	196
ILBE632C8	37.6	28.4	35490	63	126	169	33	19200	11200	3200	1100	8900	15	2 x 630		78	35	64	345
ILBE632E8	46.5	35.5	34759	62	124	225	43	28800	14400	3200	1100	11500	15	2 x 630		78	35	76	364
ILBE632G8	53.9	41.5	33975	61	122	281	54	33600	17600	3200	1100	14500	15	2 x 630		78	35	76	402
ILBE633C8	56.6	43.8	53209	66	131	252	49	28800	16800	4800	1650	13300	20	3 x 630		80	35	76	517
ILBE633E8	69.9	54.4	52099	65	129	336	65	43200	21600	4800	1650	17500	20	3 x 630		80	42	76	545
ILBE633G8	81.2	64.4	50913	63	127	420	81	50400	26400	4800	1650	22000	20	3 x 630		80	42	89	603
ILBE634C8	75.1	59.2	70928	67	135	335	65	38400	22400	6400	2200	17700	25	4 x 630		81	42	89	682
ILBE634E8	92.6	73.5	69440	66	133	447	86	57600	28800	6400	2200	23000	25	4 x 630	81	42	89	720	
ILBE634G8	107.0	85.5	67850	65	130	559	108	67200	35200	6400	2200	29000	25	4 x 630	81	2 x 42	2 x 76	797	
ILBE635C8	93.9	71.5	88647	69	138	418	81	48000	28000	8000	2750	22100	30	5 x 630	82	42	89	834	
ILBE635E8	116.3	89.3	86780	68	136	558	108	72000	36000	8000	2750	29000	30	5 x 630	82	2 x 35	2 x 76	880	
ILBE635G8	134.7	104.1	84787	67	133	697	135	84000	44000	8000	2750	36000	30	5 x 630	82	2 x 42	2 x 76	976	
ILBE801C8	29.9	22.6	31849	82	-	123	24	18000	9000	3000	700	6500	15	1 x 800	P=5100W I=8.8A n=1270min-1 V=400V 4 poles	81	28	54	243
ILBE801E8	36.9	27.8	30752	80	-	164	32	21000	12000	3000	700	8500	15	1 x 800		81	35	64	256
ILBE801G8	43.0	33.1	29726	77	-	205	39	21000	12000	3000	700	10500	15	1 x 800		81	35	64	284
ILBE802C8	59.1	46.8	63556	87	-	243	47	34200	17100	5700	1400	12800	25	2 x 800		84	42	76	500
ILBE802E8	73.1	58.2	61326	85	-	323	62	39900	22800	5700	1400	16500	25	2 x 800		84	2 x 35	2 x 64	528
ILBE802G8	84.6	67.8	59246	82	-	404	78	39900	22800	5700	1400	21000	25	2 x 800		84	2 x 35	2 x 64	583
ILBE803C8	88.8	70.3	95262	91	-	362	70	52200	26100	8700	2100	19100	30	3 x 800		86	2 x 35	2 x 64	749
ILBE803E8	109.4	87.3	91898	88	-	483	93	60900	34800	8700	2100	25000	30	3 x 800		86	2 x 42	2 x 76	790
ILBE803G8	126.9	101.7	88764	86	-	604	116	60900	34800	8700	2100	31000	30	3 x 800		86	2 x 42	2 x 76	874
ILBE804C8	118.9	89.9	126967	93	-	482	93	70200	35100	11700	2800	25500	40	4 x 800		87	2 x 35	2 x 76	989
ILBE804E8	147.4	112.6	122470	90	-	643	124	81900	46800	11700	2800	33500	40	4 x 800	87	2 x 42	2 x 89	1045	
ILBE804G8	171.1	131.7	118282	88	-	803	155	81900	46800	11700	2800	41500	40	4 x 800	87	2 x 42	2 x 89	1156	



Model	Capacity	Fluid Flow	Fluid Pressure Drop	Circuit	Air Flow	Air Throw		Surface	Tube volume	Defrost					Fan Motors n°x ø	Fan Motors	Noise	Connections		Weight	
	kW	m³/h	kPa		m³/h	-	Alfa Streamer			m²	dm³	E	EL	FRH			W	dB(A)	mm		
	Air Tin=+2°C / R.H.=85% 30%Et. Gly. Temp= -8 / -4 °C				m³/h	m	m²			dm³	W	W	W	l/h			kPa	mm	(5m)		inlet
<b>4mm Fin Spacing / High Speed Rotation</b>																					
INGW501A	8.4	2.0	32	3	7647	34	67	55	10	4200	2100	450	1500	5	1 x 500	P=790W I=1.45A n=1330min-1 V=400V 4 poles	64	1"	1"	95	
INGW501C	12.3	2.9	43	4	7108	32	63	82	16	6300	2100	450	2300	5	1 x 500		64	1"	1"	100	
INGW501D	15.2	3.5	73	4	6844	31	61	95	18	8400	4200	450	2700	5	1 x 500		64	1"	1"	103	
INGW501E	14.4	3.4	41	5	6631	30	60	109	21	8400	4200	450	3000	5	1 x 500		64	1"	1"	105	
INGW502A	20.4	4.8	65	5	15183	37	74	107	20	8400	4200	450	3000	7	2 x 500		67	1"	1"	194	
INGW502C	27.0	6.3	63	7	14102	35	70	161	31	12600	4200	450	4500	7	2 x 500		67	1"	1"	205	
INGW502D	29.1	6.8	58	8	13604	34	68	187	36	16800	8400	450	5200	7	2 x 500		67	1 1/2"	1 1/2"	210	
INGW502E	30.7	7.2	53	9	13140	33	66	214	41	16800	8400	450	5900	7	2 x 500		67	1 1/2"	1 1/2"	215	
INGW503A	32.0	7.5	80	7	22727	39	78	160	30	12600	6300	450	4500	8	3 x 500		69	1 1/2"	1 1/2"	286	
INGW503C	38.0	8.9	47	11	21135	37	74	240	46	18900	8400	450	6800	8	3 x 500		69	1 1/2"	1 1/2"	303	
INGW503D	43.0	10.0	53	12	20364	36	72	280	53	25200	12600	450	7800	8	3 x 500		69	1 1/2"	1 1/2"	311	
INGW503E	49.6	11.6	79	12	19626	35	70	319	61	25200	12600	450	8900	8	3 x 500		69	1 1/2"	1 1/2"	319	
INGW504A	39.8	9.3	57	10	30314	40	81	212	40	16200	8100	450	6000	9	4 x 500		70	1 1/2"	1 1/2"	383	
INGW504C	52.7	12.3	55	14	28129	38	77	319	60	24300	8100	450	9000	9	4 x 500		70	2"	2"	402	
INGW504D	56.9	13.3	51	16	27124	37	75	372	71	32400	16200	450	10500	9	4 x 500		70	2"	2"	413	
INGW504E	60.0	14.0	46	18	26189	37	73	425	81	32400	16200	450	12000	9	4 x 500	70	2"	2"	423		
INGW505A	47.3	11.1	46	13	37908	41	83	265	50	20400	10200	450	7500	10	5 x 500	71	2"	2"	476		
INGW505C	59.6	13.9	36	19	35212	39	79	397	75	30600	10200	450	11300	10	5 x 500	71	2"	2"	502		
INGW505D	63.0	14.7	31	22	33974	39	77	464	88	40800	20400	450	13000	10	5 x 500	71	2"	2"	515		
INGW505E	81.6	19.0	73	20	32649	38	75	530	101	40800	20400	450	15000	10	5 x 500	71	2"	2"	528		
INGW561C	18.9	4.4	45	6	10276	40	-	128	24	9600	4800	500	3500	8	1 x 560	P=1000W I=1.8A n=1220min-1 V=400V 4 poles	68	1"	1"	126	
INGW561D	19.7	4.6	37	7	9923	39	-	149	28	12000	4800	500	4200	8	1 x 560		68	1"	1"	130	
INGW561E	23.5	5.5	58	7	9559	38	-	170	32	12000	7200	500	4700	8	1 x 560		68	1"	1"	134	
INGW561F	23.6	5.5	45	8	9253	37	-	191	36	14400	7200	500	5300	8	1 x 560		68	1"	1"	143	
INGW561G	23.3	5.4	35	9	8970	36	-	213	40	14400	7200	500	6000	8	1 x 560		68	1"	1"	151	
INGW562C	39.8	9.3	55	11	20421	44	-	251	48	19200	9600	500	7100	10	2 x 560		71	1 1/2"	1 1/2"	296	
INGW562D	41.3	9.6	43	13	19704	42	-	293	56	24000	9600	500	8200	10	2 x 560		71	1 1/2"	1 1/2"	305	
INGW562E	48.1	11.2	64	13	18982	41	-	335	64	24000	14400	500	9500	10	2 x 560		71	2"	2"	313	
INGW562F	50.9	11.9	65	14	18342	40	-	377	72	28800	14400	500	10500	10	2 x 560		71	2"	2"	330	
INGW562G	54.8	12.8	83	14	17738	39	-	419	80	28800	14400	500	11500	10	2 x 560		71	2"	2"	347	
INGW563C	63.5	14.8	76	15	30539	46	-	375	71	28800	14400	500	10600	12	3 x 560		73	2"	2"	396	
INGW563D	68.7	16.0	72	17	29432	45	-	438	83	36000	14400	500	12000	12	3 x 560		73	2"	2"	410	
INGW563E	72.6	16.9	66	19	28404	43	-	500	95	36000	21600	500	14000	12	3 x 560		73	2"	2"	423	
INGW563F	75.6	17.7	61	21	27451	42	-	563	107	43200	21600	500	15500	12	3 x 560		73	2 1/2"	2 1/2"	448	
INGW563G	77.4	18.1	55	23	26572	41	-	625	119	43200	21600	500	17500	12	3 x 560		73	2 1/2"	2 1/2"	474	
INGW564C	84.2	19.7	73	20	40686	47	-	499	95	38400	19200	500	14200	15	4 x 560	74	2 1/2"	2 1/2"	549		
INGW564D	92.8	21.7	78	22	39191	46	-	582	111	48000	19200	500	16000	15	4 x 560	74	2 1/2"	2 1/2"	567		
INGW564E	99.6	23.3	79	24	37805	45	-	665	126	48000	28800	500	18500	15	4 x 560	74	2 1/2"	2 1/2"	583		
INGW564F	104.5	24.4	78	26	36526	44	-	748	142	57600	28800	500	21000	15	4 x 560	74	2 1/2"	2 1/2"	617		
INGW564G	106.2	24.8	66	29	35360	43	-	832	158	57600	28800	500	23000	15	4 x 560	74	2 1/2"	2 1/2"	650		
INGW565C	104.8	24.5	72	25	50833	49	-	623	118	48000	24000	500	17700	21	5 x 560	75	2 1/2"	2 1/2"	628		
INGW565D	108.5	25.3	53	30	49025	47	-	727	138	60000	24000	500	20000	21	5 x 560	75	2 1/2"	2 1/2"	649		
INGW565E	116.4	27.2	53	33	47291	46	-	830	158	60000	36000	500	23000	21	5 x 560	75	3"	3"	670		
INGW565F	127.0	29.7	64	34	45651	45	-	934	177	72000	36000	500	25500	21	5 x 560	75	3"	3"	712		
INGW565G	136.7	31.9	82	34	44137	44	-	1038	197	72000	36000	500	29000	21	5 x 560	75	3"	3"	755		

Model	Capacity	Fluid Flow	Fluid Pressure Drop	Circuit	Air Flow	Air Throw		Sur-face	Tube volume	Defrost				Fan Motors n°x ø	Fan Motors	Noise	Connections		Weight		
	kW	m³/h	kPa			-	Alfa Streamer			E	EL	FRH	W			dB(A)	mm				
	Air Tin=+2°C / R.H.=85% 30%Et. Gly. Temp= -8 / -4 °C					m³/h	m			m²	dm³	W	W			W	l/h	kPa		mm	(5m)
<b>4mm Fin Spacing / High Speed Rotation</b>																					
INGW631C	26.0	6.1	44	8	16417	55	110	159	30	12000	4800	550	4500	12	1 x 630	P=2600W I=4.8A n=1310min-1 V400V 4 poles	75	1"1/2	1"1/2	186	
INGW631D	29.1	6.8	46	9	15961	54	107	186	35	14400	7200	550	5200	12	1 x 630		75	1"1/2	1"1/2	191	
INGW631E	31.4	7.3	45	10	15520	52	105	213	40	14400	7200	550	6000	12	1 x 630		75	1"1/2	1"1/2	196	
INGW631F	36.4	8.5	65	10	15067	51	102	239	45	16800	9600	550	6500	12	1 x 630		75	1"1/2	1"1/2	207	
INGW631G	37.7	8.8	59	11	14666	50	100	266	50	16800	9600	550	7500	12	1 x 630		75	1"1/2	1"1/2	217	
INGW632C	57.5	13.4	67	14	32647	59	118	314	60	24000	9600	550	8900	15	2 x 630		78	2"	2"	383	
INGW632D	62.8	14.7	63	16	31724	58	115	367	70	28800	14400	550	10000	15	2 x 630		78	2"	2"	394	
INGW632E	63.8	14.9	46	19	30860	56	113	419	80	28800	14400	550	11500	15	2 x 630		78	2"	2"	404	
INGW632F	76.0	17.8	83	18	29927	55	110	471	90	33600	19200	550	13000	15	2 x 630		78	2"1/2	2"1/2	425	
INGW632G	78.2	18.3	72	20	29116	54	108	524	99	33600	19200	550	14500	15	2 x 630		78	2"1/2	2"1/2	447	
INGW633C	81.3	19.0	51	22	48950	61	123	469	89	36000	14400	550	13300	20	3 x 630		80	2"1/2	2"1/2	574	
INGW633D	85.7	20.0	41	26	47593	60	120	547	104	43200	21600	550	15500	20	3 x 630		80	2"1/2	2"1/2	590	
INGW633E	108.0	25.2	88	24	46094	59	117	625	119	43200	21600	550	17500	20	3 x 630		80	2"1/2	2"1/2	605	
INGW633F	112.5	26.2	77	27	44808	57	115	703	134	50400	28800	550	20000	20	3 x 630		80	2"1/2	2"1/2	637	
INGW633G	118.4	27.7	77	29	43566	56	113	782	148	50400	28800	550	22000	20	3 x 630		80	2"1/2	2"1/2	670	
INGW634C	100.3	23.5	37	31	65311	63	127	624	118	48000	19200	550	17700	25	4 x 630		81	2"1/2	2"1/2	758	
INGW634D	106.7	24.9	32	36	63492	62	124	728	138	57600	28800	550	20000	25	4 x 630		81	3"	3"	779	
INGW634E	140.5	32.8	75	33	61429	61	121	832	158	57600	28800	550	23000	25	4 x 630		81	3"	3"	800	
INGW634F	152.0	35.5	83	35	59666	59	118	936	178	67200	38400	550	26000	25	4 x 630		81	3"	3"	843	
INGW634G	158.7	37.1	79	38	58017	58	116	1040	197	67200	38400	550	29000	25	4 x 630		81	3"	3"	886	
INGW635C	146.7	34.3	75	33	81381	65	129	778	148	60000	24000	550	22100	30	5 x 630		82	3"	3"	926	
INGW635D	163.0	38.1	77	37	79020	63	126	908	172	72000	36000	550	25000	30	5 x 630		82	3"	3"	952	
INGW635E	172.9	40.4	69	42	76766	62	124	1038	197	72000	36000	550	29000	30	5 x 630		82	3"	3"	978	
INGW635F	171.2	40.0	47	50	74694	61	121	1168	222	84000	48000	550	33000	30	5 x 630		82	3"	3"	1031	
INGW635G	185.8	43.4	54	52	72570	59	119	1297	246	84000	48000	550	36000	30	5 x 630		82	3"	3"	1085	
INGW801C	43.8	10.2	64	11	28254	74	-	228	43	18000	9000	700	6500	15	1 x 800		P=5100W I=8.8A n=1270min-1 V=400V 4 poles	81	2"	2"	269
INGW801D	50.1	11.7	74	12	27249	71	-	267	51	21000	12000	700	7500	15	1 x 800			81	2"	2"	277
INGW801E	55.3	12.9	81	13	26330	69	-	305	58	21000	12000	700	8500	15	1 x 800			81	2"	2"	285
INGW801F	56.4	13.2	63	15	25520	67	-	343	65	21000	12000	700	9500	15	1 x 800			81	2"	2"	300
INGW801G	60.1	14.0	66	16	24739	66	-	381	72	21000	12000	700	10500	15	1 x 800			81	2"	2"	315
INGW802C	74.7	17.4	34	24	56478	79	-	451	86	34200	17100	700	12800	25	2 x 800			84	2"1/2	2"1/2	556
INGW802D	78.4	18.3	28	28	54569	77	-	527	100	39900	22800	700	14500	25	2 x 800			84	2"1/2	2"1/2	571
INGW802E	107.2	25.0	68	26	52416	75	-	602	114	39900	22800	700	16500	25	2 x 800			84	2"1/2	2"1/2	586
INGW802F	118.4	27.6	83	27	50686	73	-	677	129	39900	22800	700	19000	25	2 x 800			84	2"1/2	2"1/2	616
INGW802G	122.2	28.5	72	30	49156	71	-	752	143	39900	22800	700	21000	25	2 x 800			84	2"1/2	2"1/2	648
INGW803C	136.6	31.9	76	30	84189	82	-	674	128	52200	26100	700	19100	30	3 x 800			86	3"	3"	832
INGW803D	150.7	35.2	75	34	81204	80	-	787	149	60900	34800	700	22000	30	3 x 800			86	3"	3"	855
INGW803E	162.5	38.0	72	38	78460	78	-	899	171	60900	34800	700	25000	30	3 x 800			86	3"	3"	878
INGW803F	177.2	41.4	82	40	75884	76	-	1011	192	60900	34800	700	28000	30	3 x 800			86	3"	3"	924
INGW803G	178.7	41.7	63	46	73626	74	-	1124	213	60900	34800	700	31000	30	3 x 800			86	3"	3"	971
INGW804C	184.5	43.1	82	39	112136	84	-	897	170	70200	35100	700	25500	40	4 x 800	87		3"	3"	1099	
INGW804D	197.5	46.1	68	46	108224	82	-	1047	199	81900	46800	700	29500	40	4 x 800	87		3"	3"	1129	
INGW804E	217.5	50.9	74	50	104508	80	-	1196	227	81900	46800	700	33500	40	4 x 800	87		3"	3"	1161	
INGW804F	227.5	53.2	65	56	101172	78	-	1346	256	81900	46800	700	37000	40	4 x 800	87		3"	3"	1222	
INGW804G	246.0	57.4	76	58	97989	76	-	1495	284	81900	46800	700	41500	40	4 x 800	87		3"	3"	1285	

Model	Capacity	Fluid Flow	Fluid Pressure Drop	Circuit	Air Flow	Air Throw		Surface	Tube volume	Defrost					Fan Motors n°x ø	Fan Motors	Noise	Connections		Weight
	kW	m³/h	kPa			-	Alfa Streamer			E	EL	FRH	W	dB(A)			mm			
	Air Tin=+2°C / R.H.=85% 30%Et. Gly. Temp=-8 / -4 °C					m³/h	m			m²	dm³	W	W	W			l/h	kPa	mm	
<b>6mm Fin Spacing / High Speed Rotation</b>																				
INRW501A	4.8	1.1	12.1	3	7901	35	69	37	10	4200	2100	450	1500	5	1 x 500	P=790W I=1.45A n=1330min-1 V=400V 4 poles	64	1"	1"	93
INRW501C	7.1	1.7	16.2	4	7479	33	66	56	16	6300	2100	450	2300	5	1 x 500		64	1"	1"	98
INRW501D	12.2	2.8	49.4	4	7202	32	64	65	18	8400	4200	450	2700	5	1 x 500		64	1"	1"	101
INRW501E	14.4	3.4	76.2	4	6989	31	62	75	21	8400	4200	450	3000	5	1 x 500		64	1"	1"	103
INRW502A	15.2	3.5	38.5	5	15641	38	75	73	20	8400	4200	450	3000	7	2 x 500		67	1"	1"	190
INRW502C	21.1	4.9	40.9	7	14760	36	72	110	31	12600	4200	450	4500	7	2 x 500		67	1"	1"	201
INRW502D	23.3	5.4	39.2	8	14335	35	71	128	36	16800	8400	450	5200	7	2 x 500		67	1 1/2"	1 1/2"	206
INRW502E	25.0	5.8	36.7	9	13928	35	69	147	41	16800	8400	450	5900	7	2 x 500		67	1 1/2"	1 1/2"	211
INRW503A	24.2	5.7	49.1	7	23417	40	79	109	30	12600	6300	450	4500	8	3 x 500		69	1 1/2"	1 1/2"	280
INRW503C	35.7	8.3	73.1	9	22058	38	76	164	46	18900	8400	450	6800	8	3 x 500		69	1 1/2"	1 1/2"	297
INRW503D	40.0	9.3	77.9	10	21406	37	74	191	53	25200	12600	450	7800	8	3 x 500		69	1 1/2"	1 1/2"	305
INRW503E	41.3	9.7	57.1	12	20804	37	73	219	61	25200	12600	450	8900	8	3 x 500		69	1 1/2"	1 1/2"	312
INRW504A	33.1	7.7	55.0	9	31195	41	82	145	40	16200	8100	450	6000	9	4 x 500		70	1 1/2"	1 1/2"	375
INRW504C	44.4	10.4	50.4	13	29419	39	79	218	60	24300	8100	450	9000	9	4 x 500		70	2"	2"	394
INRW504D	53.8	12.5	82.2	13	28508	39	77	254	71	32400	16200	450	10500	9	4 x 500		70	2"	2"	404
INRW504E	57.0	13.3	70.3	15	27689	38	76	291	81	32400	16200	450	12000	9	4 x 500		70	2"	2"	415
INRW505A	33.3	7.8	24.8	13	39097	42	85	181	50	20400	10200	450	7500	10	5 x 500		71	2"	2"	467
INRW505C	58.6	13.7	67.8	15	36720	41	81	272	75	30600	10200	450	11300	10	5 x 500		71	2"	2"	492
INRW505D	65.2	15.2	67.7	17	35633	40	80	317	88	40800	20400	450	13000	10	5 x 500	71	2"	2"	504	
INRW505E	70.5	16.5	65.2	19	34596	39	78	363	101	40800	20400	450	15000	10	5 x 500	71	2"	2"	518	
INRW561C	17.7	4.1	66.2	5	10720	41	-	87	24	9600	4800	500	3500	8	1 x 560	P=1000W I=1.8A n=1220min-1 V=400V 4 poles	68	1"	1"	123
INRW561D	11.8	2.8	15.0	7	10527	41	-	102	28	12000	4800	500	4200	8	1 x 560		68	1"	1"	128
INRW561E	19.3	4.5	40.6	7	10130	39	-	116	32	12000	7200	500	4700	8	1 x 560		68	1"	1"	132
INRW561F	19.4	4.5	32.0	8	9858	39	-	131	36	14400	7200	500	5300	8	1 x 560		68	1"	1"	140
INRW561G	24.7	5.8	78.7	7	9552	38	-	146	40	14400	7200	500	6000	8	1 x 560		68	1"	1"	148
INRW562C	34.2	8.0	54.8	10	21359	45	-	172	48	19200	9600	500	7100	10	2 x 560		71	1 1/2"	1 1/2"	290
INRW562D	38.8	9.1	61.4	11	20717	44	-	201	56	24000	9600	500	8200	10	2 x 560		71	1 1/2"	1 1/2"	298
INRW562E	40.0	9.3	46.5	13	20131	43	-	229	64	24000	14400	500	9500	10	2 x 560		71	2"	2"	307
INRW562F	43.3	10.1	49.2	14	19550	42	-	258	72	28800	14400	500	10500	10	2 x 560		71	2"	2"	323
INRW562G	48.1	11.3	65.9	14	18985	41	-	287	80	28800	14400	500	11500	10	2 x 560		71	2"	2"	340
INRW563C	53.5	12.5	67.9	14	31969	47	-	257	71	28800	14400	500	10600	12	3 x 560		73	2"	2"	388
INRW563D	58.8	13.7	64.7	16	31017	46	-	300	83	36000	14400	500	12000	12	3 x 560		73	2"	2"	401
INRW563E	63.1	14.7	60.4	18	30109	45	-	342	95	36000	21600	500	14000	12	3 x 560		73	2"	2"	414
INRW563F	70.8	16.5	83.4	18	29213	44	-	385	107	43200	21600	500	15500	12	3 x 560		73	2 1/2"	2 1/2"	439
INRW563G	73.4	17.1	73.8	20	28404	43	-	428	119	43200	21600	500	17500	12	3 x 560		73	2 1/2"	2 1/2"	464
INRW564C	72.5	16.9	75.3	18	42581	49	-	342	95	38400	19200	500	14200	15	4 x 560		74	2 1/2"	2 1/2"	538
INRW564D	78.7	18.4	66.3	21	41317	48	-	398	111	48000	19200	500	16000	15	4 x 560		74	2 1/2"	2 1/2"	556
INRW564E	85.9	20.0	68.6	23	40090	47	-	455	126	48000	28800	500	18500	15	4 x 560		74	2 1/2"	2 1/2"	572
INRW564F	89.6	20.9	59.4	26	38948	46	-	512	142	57600	28800	500	21000	15	4 x 560	74	2 1/2"	2 1/2"	605	
INRW564G	92.4	21.6	51.5	29	37872	45	-	569	158	57600	28800	500	23000	15	4 x 560	74	2 1/2"	2 1/2"	637	
INRW565C	83.6	19.5	48.0	25	53276	50	-	426	118	48000	24000	500	17700	21	5 x 560	75	2 1/2"	2 1/2"	616	
INRW565D	90.7	21.2	43.0	29	51698	49	-	497	138	60000	24000	500	20000	21	5 x 560	75	2 1/2"	2 1/2"	636	
INRW565E	95.8	22.4	37.8	33	50193	48	-	568	158	60000	36000	500	23000	21	5 x 560	75	3"	3"	657	
INRW565F	117.0	27.3	78.9	30	48612	47	-	639	177	72000	36000	500	25500	21	5 x 560	75	3"	3"	698	
INRW565G	121.9	28.5	72.4	33	47255	46	-	710	197	72000	36000	500	29000	21	5 x 560	75	3"	3"	740	

Model	Capacity	Fluid Flow	Fluid Pressure Drop	Circuit	Air Flow	Air Throw		Surface	Tube volume	Defrost					Fan Motors n°x ø	Fan Motors	Noise	Connections		Weight	
	kW	m³/h	kPa			-	Alfa Streamer			E	EL	FRH	W	dB(A)			mm				
	Air Tin=+2°C / R.H.=85% 30%Et. Gly. Temp= -8 / -4 °C					m³/h	m			m²	dm³	W	W	W			l/h	kPa	mm		(5m)
<b>6mm Fin Spacing / High Speed Rotation</b>																					
INRW631C	18.0	4.2	23.4	8	17004	57	113	109	30	12000	4800	550	4500	12	1 x 630	P=2600W I=4.8A n=1310min-1 V400V 4 poles	75	1"1/2	1"1/2	182	
INRW631D	25.8	6.0	51.3	8	16583	55	111	127	35	14400	7200	550	5200	12	1 x 630		75	1"1/2	1"1/2	187	
INRW631E	28.0	6.5	49.0	9	16222	54	109	146	40	14400	7200	550	6000	12	1 x 630		75	1"1/2	1"1/2	192	
INRW631F	29.9	7.0	46.0	10	15865	53	107	164	45	16800	9600	550	6500	12	1 x 630		75	1"1/2	1"1/2	203	
INRW631G	31.3	7.3	42.8	11	15518	52	104	182	50	16800	9600	550	7500	12	1 x 630		75	1"1/2	1"1/2	213	
INRW632C	44.5	10.4	42.9	14	33800	61	121	215	60	24000	9600	550	8900	15	2 x 630		78	2"	2"	376	
INRW632D	55.7	13.0	74.5	14	33004	59	119	251	70	28800	14400	550	10000	15	2 x 630		78	2"	2"	386	
INRW632E	59.9	14.0	66.9	16	32267	58	117	287	80	28800	14400	550	11500	15	2 x 630		78	2"	2"	396	
INRW632F	63.4	14.8	60.0	18	31542	57	115	323	90	33600	19200	550	13000	15	2 x 630		78	2"1/2	2"1/2	417	
INRW632G	66.2	15.5	53.8	20	30837	56	113	358	99	33600	19200	550	14500	15	2 x 630		78	2"1/2	2"1/2	438	
INRW633C	75.0	17.5	76.7	18	50565	63	126	321	89	36000	14400	550	13300	20	3 x 630		80	2"1/2	2"1/2	563	
INRW633D	82.4	19.2	69.0	21	49451	62	124	374	104	43200	21600	550	15500	20	3 x 630		80	2"1/2	2"1/2	578	
INRW633E	91.3	21.3	73.6	23	48315	61	122	428	119	43200	21600	550	17500	20	3 x 630		80	2"1/2	2"1/2	593	
INRW633F	96.4	22.5	65.0	26	47222	60	120	481	134	50400	28800	550	20000	20	3 x 630		80	2"1/2	2"1/2	625	
INRW633G	102.8	24.0	65.8	28	46139	59	118	535	148	50400	28800	550	22000	20	3 x 630		80	2"1/2	2"1/2	657	
INRW634C	99.5	23.2	74.0	24	67389	65	130	427	118	48000	19200	550	17700	25	4 x 630		81	2"1/2	2"1/2	743	
INRW634D	112.1	26.2	77.2	27	65872	64	128	498	138	57600	28800	550	20000	25	4 x 630		81	3"	3"	764	
INRW634E	122.7	28.6	77.3	30	64363	63	125	569	158	57600	28800	550	23000	25	4 x 630		81	3"	3"	784	
INRW634F	131.7	30.7	75.6	33	62881	62	123	640	178	67200	38400	550	26000	25	4 x 630		81	3"	3"	826	
INRW634G	139.3	32.5	72.9	36	61442	61	121	711	197	67200	38400	550	29000	25	4 x 630		81	3"	3"	868	
INRW635C	118.2	27.6	55.9	32	84266	66	133	533	148	60000	24000	550	22100	30	5 x 630		82	3"	3"	908	
INRW635D	133.3	31.1	58.1	36	82369	65	130	622	172	72000	36000	550	25000	30	5 x 630		82	3"	3"	933	
INRW635E	140.7	32.9	47.8	42	80533	64	128	710	197	72000	36000	550	29000	30	5 x 630		82	3"	3"	959	
INRW635F	138.6	32.4	32.3	50	78812	63	126	799	222	84000	48000	550	33000	30	5 x 630		82	3"	3"	1010	
INRW635G	155.7	36.4	39.6	52	76924	62	124	888	246	84000	48000	550	36000	30	5 x 630		82	3"	3"	1063	
INRW801C	37.2	8.7	62.3	10	29520	77	-	156	43	18000	9000	700	6500	15	1 x 800		P=5100W I=8.8A n=1270min-1 V=400V 4 poles	81	2"	2"	264
INRW801D	39.7	9.3	49.3	12	28684	75	-	182	51	21000	12000	700	7500	15	1 x 800			81	2"	2"	272
INRW801E	47.8	11.2	78.3	12	27813	73	-	208	58	21000	12000	700	8500	15	1 x 800			81	2"	2"	279
INRW801F	51.9	12.1	81.6	13	27045	71	-	235	65	21000	12000	700	9500	15	1 x 800			81	2"	2"	294
INRW801G	53.0	12.4	63.5	15	26353	69	-	261	72	21000	12000	700	10500	15	1 x 800			81	2"	2"	309
INRW802C	78.3	18.3	81.4	18	58763	82	-	309	86	34200	17100	700	12800	25	2 x 800			84	2"1/2	2"1/2	545
INRW802D	86.1	20.1	73.3	21	57030	80	-	360	100	39900	22800	700	14500	25	2 x 800			84	2"1/2	2"1/2	560
INRW802E	92.7	21.6	66.0	24	55405	78	-	412	114	39900	22800	700	16500	25	2 x 800			84	2"1/2	2"1/2	574
INRW802F	98.2	22.9	59.4	27	53885	76	-	463	129	39900	22800	700	19000	25	2 x 800	84		2"1/2	2"1/2	604	
INRW802G	108.1	25.2	70.7	28	52401	75	-	515	143	39900	22800	700	21000	25	2 x 800	84		2"1/2	2"1/2	635	
INRW803C	113.3	26.5	66.4	28	88096	85	-	461	128	52200	26100	700	19100	30	3 x 800	86		3"	3"	816	
INRW803D	126.4	29.5	64.9	32	85462	83	-	538	149	60900	34800	700	22000	30	3 x 800	86		3"	3"	838	
INRW803E	137.6	32.1	62.2	36	82997	81	-	615	171	60900	34800	700	25000	30	3 x 800	86		3"	3"	860	
INRW803F	150.2	35.1	65.6	39	80655	79	-	692	192	60900	34800	700	28000	30	3 x 800	86		3"	3"	906	
INRW803G	158.1	36.9	60.9	43	78503	78	-	769	213	60900	34800	700	31000	30	3 x 800	86		3"	3"	952	
INRW804C	148.2	34.7	59.9	38	117434	87	-	614	170	70200	35100	700	25500	40	4 x 800	87		3"	3"	1077	
INRW804D	166.6	38.9	60.9	43	113896	85	-	716	199	81900	46800	700	29500	40	4 x 800	87		3"	3"	1106	
INRW804E	176.6	41.3	50.9	50	110671	84	-	819	227	81900	46800	700	33500	40	4 x 800	87		3"	3"	1137	
INRW804F	204.2	47.7	74.0	50	107400	82	-	921	256	81900	46800	700	37000	40	4 x 800	87		3"	3"	1198	
INRW804G	222.4	51.9	85.6	52	104447	80	-	1023	284	81900	46800	700	41500	40	4 x 800	87		3"	3"	1259	

Model	Capacity	Fluid Flow	Fluid Pressure Drop	Circuit	Air Flow	Air Throw		Surface	Tube volume	Defrost					Fan Motors n"x ø	Fan Motors	Noise	Connections		Weight			
	kW	m³/h	kPa		m³/h	-	Alfa Streamer			m²	dm³	E	EL	FRH			W	mm	dB(A)		mm		Kg
	Air Tin=+2°C / R.H.=85% 30%Et. Gly. Temp= -8 / -4 °C				m³/h	m	m²			dm³	W	W	W	l/h			kPa	mm	(5m)		inlet	outlet	
<b>8mm Fin Spacing / High Speed Rotation</b>																							
INBW501A	4.7	1.10	11.6	3	7992	35	70	29	10	4200	2100	450	1500	5	1 x 500	P=790W I=1.45A n=1330min-1 V=400V 4 poles	64	1"	1"	89			
INBW501C	6.9	1.61	15.6	4	7613	34	67	43	16	6300	2100	450	2300	5	1 x 500		64	1"	1"	94			
INBW501D	11.6	2.71	45.4	4	7373	33	65	50	18	8400	4200	450	2700	5	1 x 500		64	1"	1"	97			
INBW501E	13.9	3.25	71.3	4	7179	32	64	57	21	8400	4200	450	3000	5	1 x 500		64	1"	1"	99			
INBW502A	14.1	3.29	33.7	5	15835	38	76	56	20	8400	4200	450	3000	7	2 x 500		67	1"	1"	183			
INBW502C	19.9	4.65	36.8	7	15063	37	73	84	31	12600	4200	450	4500	7	2 x 500		67	1"	1"	194			
INBW502D	22.1	5.15	35.6	8	14683	36	72	99	36	16800	8400	450	5200	7	2 x 500		67	1 1/2"	1 1/2"	198			
INBW502E	23.8	5.56	33.6	9	14313	35	71	113	41	16800	8400	450	5900	7	2 x 500		67	1 1/2"	1 1/2"	203			
INBW503A	22.6	5.28	43.5	7	23712	40	80	84	30	12600	6300	450	4500	8	3 x 500		69	1 1/2"	1 1/2"	270			
INBW503C	33.9	7.92	66.7	9	22519	39	77	126	46	18900	8400	450	6800	8	3 x 500		69	1 1/2"	1 1/2"	287			
INBW503D	38.4	8.96	72.4	10	21934	38	76	147	53	25200	12600	450	7800	8	3 x 500		69	1 1/2"	1 1/2"	294			
INBW503E	42.0	9.82	74.7	11	21367	37	74	168	61	25200	12600	450	8900	8	3 x 500		69	1 1/2"	1 1/2"	301			
INBW504A	31.1	7.26	49.3	9	31591	41	83	112	40	16200	8100	450	6000	9	4 x 500		70	1 1/2"	1 1/2"	362			
INBW504C	42.1	9.82	45.7	13	30034	40	80	167	60	24300	8100	450	9000	9	4 x 500		70	2"	2"	380			
INBW504D	51.6	12.05	76.5	13	29215	39	79	195	71	32400	16200	450	10500	9	4 x 500		70	2"	2"	390			
INBW504E	55.0	12.84	65.9	15	28469	39	77	223	81	32400	16200	450	12000	9	4 x 500		70	2"	2"	400			
INBW505A	42.4	9.89	78.1	10	39443	43	85	139	50	20400	10200	450	7500	10	5 x 500		71	2"	2"	450			
INBW505C	58.5	13.66	81.9	14	37469	41	82	209	75	30600	10200	450	11300	10	5 x 500		71	2"	2"	474			
INBW505D	62.5	14.61	62.9	17	36517	40	81	244	88	40800	20400	450	13000	10	5 x 500		71	2"	2"	486			
INBW505E	70.1	16.36	75.0	18	35553	40	79	279	101	40800	20400	450	15000	10	5 x 500		71	2"	2"	499			
INBW561C	16.8	3.93	60.6	5	10942	42	-	67	24	9600	4800	500	3500	8	1 x 560	P=1000W I=1.8A n=1220min-1 V=400V 4 poles	68	1"	1"	119			
INBW561D	11.6	2.70	14.4	7	10761	42	-	78	28	12000	4800	500	4200	8	1 x 560		68	1"	1"	123			
INBW561E	18.4	4.31	37.5	7	10410	40	-	89	32	12000	7200	500	4700	8	1 x 560		68	1"	1"	127			
INBW561F	18.4	4.31	29.2	8	10162	40	-	101	36	14400	7200	500	5300	8	1 x 560		68	1"	1"	135			
INBW561G	24.1	5.63	75.3	7	9874	39	-	112	40	14400	7200	500	6000	8	1 x 560		68	1"	1"	143			
INBW562C	32.5	7.61	50.1	10	21810	46	-	132	48	19200	9600	500	7100	10	2 x 560		71	1 1/2"	1 1/2"	279			
INBW562D	37.1	8.65	56.4	11	21235	45	-	154	56	24000	9600	500	8200	10	2 x 560		71	1 1/2"	1 1/2"	288			
INBW562E	38.4	8.97	43.3	13	20701	44	-	176	64	24000	14400	500	9500	10	2 x 560		71	2"	2"	296			
INBW562F	41.8	9.75	46.0	14	20165	43	-	198	72	28800	14400	500	10500	10	2 x 560		71	2"	2"	312			
INBW562G	46.8	10.91	62.4	14	19638	42	-	220	80	28800	14400	500	11500	10	2 x 560		71	2"	2"	327			
INBW563C	50.8	11.86	61.8	14	32654	48	-	197	71	28800	14400	500	10600	12	3 x 560		73	2"	2"	374			
INBW563D	56.3	13.17	60.0	16	31797	47	-	230	83	36000	14400	500	12000	12	3 x 560		73	2"	2"	387			
INBW563E	60.8	14.20	56.6	18	30969	46	-	263	95	36000	21600	500	14000	12	3 x 560		73	2"	2"	399			
INBW563F	68.7	16.06	79.2	18	30141	45	-	296	107	43200	21600	500	15500	12	3 x 560		73	2 1/2"	2 1/2"	424			
INBW563G	73.3	17.12	84.8	19	29372	44	-	329	119	43200	21600	500	17500	12	3 x 560		73	2 1/2"	2 1/2"	448			
INBW564C	69.1	16.16	69.3	18	43498	50	-	262	95	38400	19200	500	14200	15	4 x 560		74	2 1/2"	2 1/2"	518			
INBW564D	75.4	17.63	61.6	21	42361	49	-	306	111	48000	19200	500	16000	15	4 x 560		74	2 1/2"	2 1/2"	536			
INBW564E	80.5	18.83	54.6	24	41261	48	-	350	126	48000	28800	500	18500	15	4 x 560		74	2 1/2"	2 1/2"	551			
INBW564F	86.8	20.29	56.2	26	40186	47	-	393	142	57600	28800	500	21000	15	4 x 560		74	2 1/2"	2 1/2"	583			
INBW564G	97.9	22.85	86.0	25	39121	46	-	437	158	57600	28800	500	23000	15	4 x 560		74	2 1/2"	2 1/2"	615			
INBW565C	79.1	18.47	43.5	25	54420	51	-	327	118	48000	24000	500	17700	21	5 x 560	75	2 1/2"	2 1/2"	594				
INBW565D	86.2	20.13	39.2	29	53003	50	-	382	138	60000	24000	500	20000	21	5 x 560	75	2 1/2"	2 1/2"	613				
INBW565E	91.8	21.44	35.1	33	51632	49	-	437	158	60000	36000	500	23000	21	5 x 560	75	3"	3"	633				
INBW565F	113.3	26.43	74.3	30	50166	48	-	491	177	72000	36000	500	25500	21	5 x 560	75	3"	3"	673				
INBW565G	120.7	28.19	77.5	32	48882	47	-	546	197	72000	36000	500	29000	21	5 x 560	75	3"	3"	714				

Model	Capacity	Fluid Flow	Fluid Pressure Drop	Circuit	Air Flow	Air Throw		Surface	Tube volume	Defrost					Fan Motors n"x ø	Fan Motors	Noise	Connections		Weight	
	kW	m³/h	kPa			-	Alfa Streamer			E	EL	FRH	W				dB(A)	mm			
	Air Tin=+2°C / R.H.=85% 30%Et. Gly. Temp=-8 / -4 °C					m³/h	m			m²	dm³	W	W	W			l/h	kPa	mm		(5m)
<b>8mm Fin Spacing / High Speed Rotation</b>																					
INBW631C	13.3	3.10	13.6	8	17351	58	115	84	30	12000	4800	550	4500	12	1 x 630	P=2600W I=4.8A n=1310min-1 V400V 4 poles	75	1 1/2	1 1/2	176	
INBW631D	24.6	5.74	47.0	8	16875	56	112	98	35	14400	7200	550	5200	12	1 x 630		75	1 1/2	1 1/2	181	
INBW631E	26.8	6.26	45.2	9	16560	55	111	112	40	14400	7200	550	6000	12	1 x 630		75	1 1/2	1 1/2	186	
INBW631F	28.7	6.70	42.9	10	16245	54	109	126	45	16800	9600	550	6500	12	1 x 630		75	1 1/2	1 1/2	195	
INBW631G	30.2	7.05	40.1	11	15933	53	107	140	50	16800	9600	550	7500	12	1 x 630		75	1 1/2	1 1/2	205	
INBW632C	48.2	11.24	75.4	12	34246	61	123	165	60	24000	9600	550	8900	15	2 x 630		78	2"	2"	362	
INBW632D	53.1	12.40	68.3	14	33609	60	121	193	70	28800	14400	550	10000	15	2 x 630		78	2"	2"	372	
INBW632E	57.4	13.39	61.8	16	32963	59	119	220	80	28800	14400	550	11500	15	2 x 630		78	2"	2"	382	
INBW632F	60.9	14.22	55.8	18	32319	58	117	248	90	33600	19200	550	13000	15	2 x 630		78	2 1/2	2 1/2	402	
INBW632G	63.9	14.91	50.4	20	31684	58	115	275	99	33600	19200	550	14500	15	2 x 630		78	2 1/2	2 1/2	422	
INBW633C	71.5	16.68	70.4	18	51328	64	128	247	89	36000	14400	550	13300	20	3 x 630		80	2 1/2	2 1/2	542	
INBW633D	81.5	19.05	77.7	20	50343	63	126	288	104	43200	21600	550	15500	20	3 x 630		80	2 1/2	2 1/2	558	
INBW633E	85.1	19.86	57.7	24	49388	62	124	329	119	43200	21600	550	17500	20	3 x 630		80	2 1/2	2 1/2	572	
INBW633F	93.1	21.75	61.1	26	48393	61	122	370	134	50400	28800	550	20000	20	3 x 630		80	2 1/2	2 1/2	602	
INBW633G	99.7	23.29	62.4	28	47416	60	120	411	148	50400	28800	550	22000	20	3 x 630		80	2 1/2	2 1/2	633	
INBW634C	97.6	22.81	80.8	23	68389	66	131	328	118	48000	19200	550	17700	25	4 x 630		81	2 1/2	2 1/2	716	
INBW634D	107.3	25.09	71.6	27	67097	65	129	383	138	57600	28800	550	20000	25	4 x 630		81	3"	3"	737	
INBW634E	118.0	27.57	72.2	30	65771	64	127	437	158	57600	28800	550	23000	25	4 x 630		81	3"	3"	756	
INBW634F	127.2	29.71	71.2	33	64451	63	125	492	178	67200	38400	550	26000	25	4 x 630		81	3"	3"	797	
INBW634G	135.2	31.56	69.2	36	63152	62	124	546	197	67200	38400	550	29000	25	4 x 630		81	3"	3"	837	
INBW635C	112.0	26.13	50.7	32	85540	67	134	409	148	60000	24000	550	22100	30	5 x 630		82	3"	3"	875	
INBW635D	127.3	29.75	53.7	36	83897	66	132	477	172	72000	36000	550	25000	30	5 x 630		82	3"	3"	900	
INBW635E	134.8	31.52	44.4	42	82285	65	130	546	197	72000	36000	550	29000	30	5 x 630		82	3"	3"	924	
INBW635F	132.5	30.98	29.9	50	80761	64	128	614	222	84000	48000	550	33000	30	5 x 630		82	3"	3"	974	
INBW635G	149.9	35.00	37.0	52	79057	63	126	682	246	84000	48000	550	36000	30	5 x 630		82	3"	3"	1025	
INBW801C	35.5	8.29	57.5	10	30136	78	-	120	43	18000	9000	700	6500	15	1 x 800		P=5100W I=8.8A n=1270min-1 V=400V 4 poles	81	2"	2"	255
INBW801D	38.0	8.87	45.6	12	29370	76	-	140	51	21000	12000	700	7500	15	1 x 800			81	2"	2"	262
INBW801E	43.1	10.05	52.1	13	28600	75	-	160	58	21000	12000	700	8500	15	1 x 800			81	2"	2"	269
INBW801F	50.3	11.75	77.3	13	27846	73	-	180	65	21000	12000	700	9500	15	1 x 800			81	2"	2"	284
INBW801G	51.4	11.99	59.9	15	27197	71	-	200	72	21000	12000	700	10500	15	1 x 800			81	2"	2"	298
INBW802C	75.0	17.52	75.5	18	60016	83	-	237	86	34200	17100	700	12800	25	2 x 800			84	2 1/2	2 1/2	525
INBW802D	82.8	19.33	68.5	21	58424	82	-	277	100	39900	22800	700	14500	25	2 x 800			84	2 1/2	2 1/2	540
INBW802E	89.4	20.89	62.0	24	56919	80	-	316	114	39900	22800	700	16500	25	2 x 800			84	2 1/2	2 1/2	554
INBW802F	95.1	22.21	56.1	27	55499	78	-	356	129	39900	22800	700	19000	25	2 x 800	84		2 1/2	2 1/2	582	
INBW802G	105.2	24.58	67.5	28	54100	77	-	395	143	39900	22800	700	21000	25	2 x 800	84		2 1/2	2 1/2	612	
INBW803C	108.5	25.36	61.5	28	89978	87	-	354	128	52200	26100	700	19100	30	3 x 800	86		3"	3"	787	
INBW803D	121.5	28.38	60.5	32	87559	85	-	413	149	60900	34800	700	22000	30	3 x 800	86		3"	3"	808	
INBW803E	132.7	31.01	58.4	36	85274	83	-	473	171	60900	34800	700	25000	30	3 x 800	86		3"	3"	829	
INBW803F	145.1	33.87	61.6	39	83089	81	-	532	192	60900	34800	700	28000	30	3 x 800	86		3"	3"	873	
INBW803G	153.4	35.79	57.6	43	81061	80	-	591	213	60900	34800	700	31000	30	3 x 800	86		3"	3"	918	
INBW804C	141.3	32.99	54.9	38	119950	89	-	472	170	70200	35100	700	25500	40	4 x 800	87		3"	3"	1038	
INBW804D	160.0	37.41	56.8	43	116695	87	-	550	199	81900	46800	700	29500	40	4 x 800	87		3"	3"	1067	
INBW804E	169.6	39.60	47.3	50	113713	85	-	629	227	81900	46800	700	33500	40	4 x 800	87		3"	3"	1097	
INBW804F	198.1	46.30	70.2	50	110648	84	-	707	256	81900	46800	700	37000	40	4 x 800	87		3"	3"	1155	
INBW804G	216.7	50.58	81.9	52	107864	82	-	786	284	81900	46800	700	41500	40	4 x 800	87		3"	3"	1214	

# AirMax II NH<sub>3</sub>

## Product Description

### Applications

This new Industrial Line of cubic coolers is designed to keep refrigerated fresh and frozen goods in medium to very large size of cold storages. This is possible thanks to a wide range of capacity (from 18 to 160 kW), through the availability of different fan diameters (up to 800 mm), several fin spacings and a long list of options. With the new frame design and the improved features in the coil manufacturing, the industrial line allows the clients to select the best model to fit all the needs in the heavy application of the ammonia installations.

### Standard design

#### Coil

The heat exchanger is designed to offer the best performance in cooling for the considered application in order to minimize the refrigerant charge. The coil pitch is 60 x 60, with the tubes in line of 16 mm stainless steel material and aluminium fins. This new pattern is characterized by a large heat exchanger surface which ensures longer intervals between defrost cycles. The only one inlet and outlet connection, with combination of the different large fin spacing (6, 8, 10 and 12 mm) and the several coil block modules make the new line an innovative product range in the market.

#### Casing

All units use galvanized steel painted RAL 9002, while the drip tray is in aluminium painted. The frame has been designed in order to ensure an easy installation and maintenance. A large and deep drip tray permits a fast discharge of the water defrosting, with regard to the bottom storage goods. The supports have two different positions (flush mounted or space) to consent to install the water defrost cassette. Structural parts are fastened with stainless steel bolts and screws. Structures made of galvanized steel, with optimized length to permit uniform air suction in the coil.

### Benefits

- High energy efficiency class
- Plug-in installation
- Easy maintenance
- Correct design for any working conditions
- Silence installation
- Performance reliable
- Safety equipment
- Several options available

### Options

- Fan prewired to common terminal box
- Stainless steel drip tray
- Insulated drip tray
- Stainless steel casing
- Special powerful fan motors
- Air throw fan cowl



- AlfaStreamer
- Air sock adapter ring
- Fan ring heater
- Epoxy pre-coated fins
- Cataphoresis treatment
- Floor mounting supports
- Motor cabling
- Hot gas defrost (coil + drip tray) fully connected
- Hot gas defrost loose
- Electric defrost
- Light electric defrost
- Water defrost
- Combined defrost systems

**Fans**

Four different fan diameters available: 500, 560, 630 and 800 with three-phase motors (4/6 poles) 400V-50/60 Hz. The motors are with external rotor, constructed in accordance with VDE 0530/12.84. Protection class IP 54 according to DIN40050. Integrated thermal protection by thermo contacts, provide reliable protection against thermal overload. Sickle bladed die cast aluminium impeller and fan guard of steel cataphoresis black coated. All the standard fan motors can work down to -40°C; special lubrication is suitable upon request.

For air temperature lower than +20°C, the full load current (FLC) can be calculated by using the correction factor table. The overload protectors should have 20% margin to accommodate fan motor supplier variations.

T [°C]	20	10	0	-10	-15	-20	-25	-30
Fc	1	1,04	1,08	1,12	1,14	1,16	1,18	1,2



MODEL	Ca-pacity	Capac-ity	Air Flow	Air Throw m		Sur-face	Tube volume	Defrost W				Fan Motors Ø mm x n°	Motor data	Noise Level dB(A)	Connections		Weight [kg]
	T.air 0C°/ T.ev -8C°	T.air -25C°/ T.ev -32C°	m³/h	-	Alfa Streamer	[m²]	[dm³]	E	EL	HG+E (tray)	FRH				5 mt	IN	
<b>Fin Spacing 4 mm / High speed Rotation</b>																	
ILGA501A4	11.15	9.581	7873	35	70	75.82	8.1	5600	2800	1400	450	500 X1	P=790W I=1.45A n=1330min-1 V=400V 4 poles	64	1"	1 1/2"	103.7
ILGA501B4	12.8	10.9	7587	34	68	94.77	10.1	6300	3500	1400	450	500 X1		64	1"	1 1/2"	108.7
ILGA501C4	14.67	11.91	7308	33	66	113.7	12.2	7000	3500	1400	450	500 X1		64	1"	1 1/2"	113.7
ILGA502A4	24.58	19.59	15640	38	76	149.1	15.9	11200	5600	2800	900	500 X2		67	1"	1 1/2"	212.4
ILGA502B4	29.59	22.59	15050	37	74	186.3	19.9	12600	7000	2800	900	500 X2		67	1"	1 1/2"	222.4
ILGA502C4	32.63	24.93	14500	36	72	223.6	23.9	14000	7000	2800	900	500 X2		67	1"	1 1/2"	232.4
ILGA503A4	35.94	26.05	23410	40	80	222.3	23.8	16800	8400	4200	1350	500 X3		69	1"	1 1/2"	313.1
ILGA503B4	43.47	30.41	22520	39	78	277.9	29.7	18900	10500	4200	1350	500 X3		69	1"	1 1/2"	330.1
ILGA503C4	48.14	33.97	21700	38	76	333.4	35.6	21000	10500	4200	1350	500 X3		69	1"	1 1/2"	344.1
ILGA504A4	48.96	39.2	31220	41	82	295.5	31.6	21600	10800	5400	1800	500 X4		70	1"	2"	418.8
ILGA504B4	58.92	45.17	30020	40	80	369.4	39.5	24300	13500	5400	1800	500 X4		70	1"	2"	437.8
ILGA504C4	64.97	49.82	28910	39	78	443.3	47.4	27000	13500	5400	1800	500 X4		70	1"	2"	457.8
ILGA505A4	60.98	46.58	38990	42	84	368.8	39.4	27200	13600	6800	2250	500 X5		71	1"	2"	522.5
ILGA505B4	73.52	54.02	37490	41	82	460.9	49.3	30600	17000	6800	2250	500 X5		71	1"	2"	546.5
ILGA505C4	81.18	59.89	36110	41	82	553.1	59.1	34000	17000	6800	2250	500 X5		71	1"	2"	571.5
ILGA561B4	21.78	16.96	10610	41	-	147.9	15.8	8000	4000	1600	500	560 X1	P=1000W I=1.80A n=1220min-1 V=400V 4 poles	68	1"	2"	136.5
ILGA561C4	23.89	18.44	10230	40	-	177.5	19.0	9600	4800	1600	500	560 X1		68	1"	2"	144.5
ILGA561D4	25.38	19.49	9867	39	-	207.1	22.1	12000	6400	1600	500	560 X1		68	1"	2"	160.5
ILGA562B4	42.84	29.76	21110	45	-	291.5	31.2	16000	8000	3200	1000	560 X2		71	1"	2"	315.0
ILGA562C4	47.21	33.1	20330	44	-	349.8	37.4	19200	9600	3200	1000	560 X2		71	1"	2"	331.0
ILGA562D4	50.47	35.68	19600	43	-	408.1	43.6	24000	12800	3200	1000	560 X2		71	1"	2"	363.0
ILGA563B4	65.6	48.93	31620	47	-	435.1	46.5	24000	12000	4800	1500	560 X3		73	1"	2"	426.5
ILGA563C4	71.97	53.84	30450	46	-	522.1	55.8	28800	14400	4800	1500	560 X3		73	1"	2"	452.5
ILGA563D4	76.66	57.47	29350	45	-	609.1	65.1	36000	19200	4800	1500	560 X3		73	1"	2"	500.5
ILGA564B4	85.69	59.87	42120	49	-	578.7	61.9	32000	16000	6400	2000	560 X4		74	1 1/2"	2 1/2"	589.0
ILGA564C4	94.38	66.54	40550	48	-	694.4	74.2	38400	19200	6400	2000	560 X4		74	1 1/2"	2 1/2"	622.0
ILGA564D4	100.8	71.65	39080	47	-	810.2	86.6	48000	25600	6400	2000	560 X4		74	1 1/2"	2 1/2"	685.0
ILGA565B4	108.8	79.61	52630	50	-	722.3	77.2	40000	20000	8000	2500	560 X5		75	1 1/2"	2 1/2"	680.5
ILGA565C4	119.5	87.84	50670	49	-	866.7	92.7	48000	24000	8000	2500	560 X5		75	1 1/2"	2 1/2"	720.5
ILGA565D4	127.4	94	48830	48	-	1011	108.1	60000	32000	8000	2500	560 X5		75	1 1/2"	2 1/2"	801.5
ILGA631B4	30.25	22.98	15930	54	108	184.9	19.8	9600	4800	1600	550	630 X1	P=2600W I=4.8A n=1310min-1 V=400V 4 poles	75	1"	2"	192.5
ILGA631C4	33.68	25.59	15530	53	106	221.9	23.7	12000	5600	1600	550	630 X1		75	1"	2"	202.5
ILGA631D4	36.42	27.62	15140	52	104	258.8	27.7	14400	7200	1600	550	630 X1		75	1"	2"	222.5
ILGA632B4	60.11	45.97	31760	58	116	364.4	38.9	19200	9600	3200	1100	630 X2		78	1"	2"	396.0
ILGA632C4	66.92	51.16	30940	57	114	437.3	46.7	24000	11200	3200	1100	630 X2		78	1"	2"	416.0
ILGA632D4	72.35	55.18	30160	56	112	510.1	54.5	28800	14400	3200	1100	630 X2		78	1"	2"	457.0
ILGA633B4	88.49	61.93	47580	61	122	543.9	58.1	28800	14400	4800	1650	630 X3		80	1 1/2"	2 1/2"	593.5
ILGA633C4	98.89	69.69	46340	59	118	652.6	69.8	36000	16800	4800	1650	630 X3		80	1 1/2"	2 1/2"	622.5
ILGA633D4	107.3	76.04	45160	58	116	761.4	81.4	43200	21600	4800	1650	630 X3		80	1 1/2"	2 1/2"	684.5
ILGA634B4	119.3	86.28	63410	62	124	723.4	77.3	38400	19200	6400	2200	630 X4		81	1 1/2"	3"	784.0
ILGA634C4	133.1	96.69	61750	61	122	868.0	92.8	48000	22400	6400	2200	630 X4		81	1 1/2"	3"	824.0
ILGA634D4	144.2	105.1	60170	60	120	1013	108.3	57600	28800	6400	2200	630 X4		81	1 1/2"	3"	906.0
ILGA635B4	145.2	98.88	79230	64	128	902.9	96.5	48000	24000	8000	2750	630 X5		82	1 1/2"	3"	959.5
ILGA635C4	162.5	111.7	77150	63	126	1083	115.8	60000	28000	8000	2750	630 X5		82	1 1/2"	3"	1010
ILGA635D4	176.6	122.3	75170	62	124	1264	135.1	72000	36000	8000	2750	630 X5		82	1 1/2"	3"	1111
ILGA801B4	45.59	32.70	29170	54	-	264.9	28.3	15000	8000	3000	700	800 X1	P=5100W I=8.8A n=1270min-1 V=400V 4 poles	81	1"	1 1/2"	277.0
ILGA801C4	53.34	37.05	28080	53	-	317.9	34.0	18000	9000	3000	700	800 X1		81	1"	1 1/2"	291.0
ILGA801D4	58.16	40.73	27110	52	-	370.9	39.6	21000	11000	3000	700	800 X1		81	1"	1 1/2"	320.0
ILGA802B4	91.19	66.10	58130	60	-	523.4	55.9	28500	15200	5700	1400	800 X2		84	1 1/2"	2 1/2"	570.0
ILGA802C4	106.6	74.79	55920	58	-	628.1	67.1	34200	17100	5700	1400	800 X2		84	1 1/2"	2 1/2"	598.0
ILGA802D4	116.2	82.12	53960	57	-	732.8	78.3	39900	20900	5700	1400	800 X2		84	1 1/2"	2 1/2"	657.0
ILGA803B4	136.8	99.48	87080	63	-	781.9	83.6	43500	23200	8700	2100	800 X3		86	1 1/2"	3"	853.0
ILGA803C4	159.9	112.5	83750	62	-	938.3	100.3	52200	26100	8700	2100	800 X3		86	1 1/2"	3"	896.0
ILGA803D4	174.2	123.5	80800	60	-	1095	117.0	60900	31900	8700	2100	800 X3		86	1 1/2"	3"	985.0
ILGA804B4	182.4	132.9	116000	65	-	1040	111.2	58500	31200	11700	2800	800 X4		87	1 1/2"	3"	1126
ILGA804C4	213.2	150.3	111600	64	-	1248	133.4	70200	35100	11700	2800	800 X4		87	1 1/2"	3"	1185
ILGA804D4	220.7	144.1	107600	63	-	1457	155.7	81900	42900	11700	2800	800 X4		87	1 1/2"	3"	1303

MODEL	Ca-pacity		Air Flow m³/h	Air throw m		Sur-face [m²]	Tube volume [dm³]	Defrost W				Fan Motors Ø mm x n°	Motor data	Noise Level dB(A)	Connections		Weight [kg]
	T.air 0C°/ T.ev -8C°	T.air -25C°/ T.ev -32C°		-	Alfa Streamer			E	EL	HG+E (tray)	FRH				5 mt	IN	
<b>Fin Spacing 6 mm / High speed Rotation</b>																	
ILRA501A6	8.409	7.413	8127	35	70	51.32	8.1	5600	2800	1400	450	500 X1	P=790W I=1.45A n=1330min-1 V=400V 4 poles	64	1"	1"1/2	101.7
ILRA501B6	9.926	8.684	7901	35	70	64.15	10.1	6300	3500	1400	450	500 X1		64	1"	1"1/2	106.7
ILRA501C6	11.22	9.748	7675	34	68	76.98	12.2	7000	3500	1400	450	500 X1		64	1"	1"1/2	111.7
ILRA502A6	19.45	16.01	16160	39	78	100.9	15.9	11200	5600	2800	900	500 X2		67	1"	1"1/2	208.4
ILRA502B6	23.03	18.81	15680	38	76	126.1	19.9	12600	7000	2800	900	500 X2		67	1"	1"1/2	218.4
ILRA502C6	27.27	21.15	15200	37	74	151.3	23.9	14000	7000	2800	900	500 X2		67	1"	1"1/2	228.4
ILRA503A6	29.09	22.18	24190	41	82	150.5	23.8	16800	8400	4200	1350	500 X3		69	1"	1"1/2	308.1
ILRA503B6	34.51	26.34	23470	40	80	188.1	29.7	18900	10500	4200	1350	500 X3		69	1"	1"1/2	324.1
ILRA503C6	40.79	29.92	22760	39	78	225.7	35.6	21000	10500	4200	1350	500 X3		69	1"	1"1/2	338.1
ILRA504A6	38.7	31.96	32260	42	84	200.0	31.6	21600	10800	5400	1800	500 X4		70	1"	2"	411.8
ILRA504B6	45.83	37.53	31300	41	82	250.1	39.5	24300	13500	5400	1800	500 X4		70	1"	2"	430.8
ILRA504C6	54.31	42.18	30330	41	82	300.1	47.4	27000	13500	5400	1800	500 X4		70	1"	2"	449.8
ILRA505A6	48.67	38.8	40300	43	86	249.6	39.4	27200	13600	6800	2250	500 X5		71	1"	2"	513.5
ILRA505B6	57.67	45.87	39090	43	86	312.0	49.3	30600	17000	6800	2250	500 X5		71	1"	2"	536.5
ILRA505C6	68.17	51.9	37880	42	84	374.4	59.1	34000	17000	6800	2250	500 X5		71	1"	2"	561.5
ILRA561B6	16.82	13.9	11050	43	-	100.1	15.8	8000	4000	1600	500	560 X1		P=1000W I=1.80A n=1220min-1 V=400V 4 poles	68	1"	2"
ILRA561C6	19.76	15.53	10720	42	-	120.1	19.0	9600	4800	1600	500	560 X1	68		1"	2"	141.5
ILRA561D6	21.43	16.89	10410	41	-	140.2	22.1	12000	6400	1600	500	560 X1	68		1"	2"	157.5
ILRA562B6	35.9	25.97	21970	46	-	197.3	31.2	16000	8000	3200	1000	560 X2	71		1"	2"	309.0
ILRA562C6	40.35	29.4	21330	45	-	236.8	37.4	19200	9600	3200	1000	560 X2	71		1"	2"	325.0
ILRA562D6	44.13	32.28	20700	45	-	276.2	43.6	24000	12800	3200	1000	560 X2	71		1"	2"	356.0
ILRA563B6	51.49	41.51	32960	49	-	294.5	46.5	24000	12000	4800	1500	560 X3	73		1"	2"	419.5
ILRA563C6	60.74	46.59	31950	48	-	353.4	55.8	28800	14400	4800	1500	560 X3	73		1"	2"	444.5
ILRA563D6	66.31	50.69	31010	47	-	412.3	65.1	36000	19200	4800	1500	560 X3	73		1"	2"	491.5
ILRA564B6	71.69	52.13	43870	50	-	391.7	61.9	32000	16000	6400	2000	560 X4	74		1"1/2	2"1/2	578.0
ILRA564C6	80.56	58.98	42560	49	-	470.1	74.2	38400	19200	6400	2000	560 X4	74		1"1/2	2"1/2	610.0
ILRA564D6	88.09	64.71	41300	48	-	548.4	86.6	48000	25600	6400	2000	560 X4	74		1"1/2	2"1/2	673.0
ILRA565B6	85.7	68.05	54870	52	-	488.9	77.2	40000	20000	8000	2500	560 X5	75		1"1/2	2"1/2	668.5
ILRA565C6	101.2	76.69	53190	51	-	586.7	92.7	48000	24000	8000	2500	560 X5	75		1"1/2	2"1/2	707.5
ILRA565D6	110.5	83.73	51600	50	-	684.5	108.1	60000	32000	8000	2500	560 X5	75		1"1/2	2"1/2	787.5
ILRA631B6	23.35	19.03	16390	55	110	125.1	19.8	9600	4800	1600	550	630 X1	P=2600W I=4.8A n=1310min-1 V=400V 4 poles		75	1"	2"
ILRA631C6	26.52	21.54	16050	54	108	150.2	23.7	12000	5600	1600	550	630 X1		75	1"	2"	198.5
ILRA631D6	30.69	23.67	15720	53	106	175.2	27.7	14400	7200	1600	550	630 X1		75	1"	2"	218.5
ILRA632B6	46.31	37.94	32700	59	118	246.6	38.9	19200	9600	3200	1100	630 X2		78	1"	2"	389.0
ILRA632C6	52.64	42.92	32010	58	116	296.0	46.7	24000	11200	3200	1100	630 X2		78	1"	2"	408.0
ILRA632D6	60.9	47.15	31340	57	114	345.3	54.5	28800	14400	3200	1100	630 X2		78	1"	2"	448.0
ILRA633B6	69.56	53.23	48990	62	124	368.2	58.1	28800	14400	4800	1650	630 X3		80	1"1/2	2"1/2	582.5
ILRA633C6	82.84	60.78	47920	61	122	441.8	69.8	36000	16800	4800	1650	630 X3		80	1"1/2	2"1/2	611.5
ILRA633D6	91.54	67.36	46930	60	120	515.4	81.4	43200	21600	4800	1650	630 X3		80	1"1/2	2"1/2	671.5
ILRA634B6	93.01	73.16	65300	64	128	489.7	77.3	38400	19200	6400	2200	630 X4		81	1"1/2	3"	769.0
ILRA634C6	111.1	83.35	63870	63	126	587.6	92.8	48000	22400	6400	2200	630 X4		81	1"1/2	3"	809.0
ILRA634D6	122.3	92.15	62550	62	124	685.5	108.3	57600	28800	6400	2200	630 X4		81	1"1/2	3"	889.0
ILRA635B6	115	85.92	81590	65	130	611.2	96.5	48000	24000	8000	2750	630 X5		82	1"1/2	3"	942.5
ILRA635C6	136.9	98.31	79800	64	128	733.4	115.8	60000	28000	8000	2750	630 X5		82	1"1/2	3"	990.5
ILRA635D6	151.4	109.2	78140	63	126	855.6	135.1	72000	36000	8000	2750	630 X5		82	1"1/2	3"	1090
ILRA801B6	37.29	28.21	30440	56	-	179.3	28.3	15000	8000	3000	700	800 X1		P=5100W I=8.8A n=1270min-1 V=400 V 4 poles	81	1"	1"1/2
ILRA801C6	42.75	32.39	29490	55	-	215.2	34.0	18000	9000	3000	700	800 X1	81		1"	1"1/2	286.0
ILRA801D6	49.70	36.08	28580	54	-	251.1	39.6	21000	11000	3000	700	800 X1	81		1"	1"1/2	314.0
ILRA802B6	74.34	56.75	60690	61	-	354.3	55.9	28500	15200	5700	1400	800 X2	84		1"1/2	2"1/2	559.0
ILRA802C6	85.20	65.13	58780	60	-	425.2	67.1	34200	17100	5700	1400	800 X2	84		1"1/2	2"1/2	587.0
ILRA802D6	94.68	72.49	56980	59	-	496.0	78.3	39900	20900	5700	1400	800 X2	84		1"1/2	2"1/2	645.0
ILRA803B6	111.4	85.32	90940	65	-	529.3	83.6	43500	23200	8700	2100	800 X3	86		1"1/2	3"	837.0
ILRA803C6	127.6	97.86	88070	63	-	635.1	100.3	52200	26100	8700	2100	800 X3	86		1"1/2	3"	879.0
ILRA803D6	141.6	108.9	85360	62	-	741.0	117.0	60900	31900	8700	2100	800 X3	86		1"1/2	3"	967.0
ILRA804B6	148.4	113.9	121200	67	-	704.2	111.2	58500	31200	11700	2800	800 X4	87		1"1/2	3"	1105
ILRA804C6	170.1	130.6	117400	66	-	845.1	133.4	70200	35100	11700	2800	800 X4	87		1"1/2	3"	1163
ILRA804D6	190.9	130.7	113600	64	-	985.9	155.7	81900	42900	11700	2800	800 X4	87		1"1/2	3"	1279

MODEL	Capacity SC2	Capacity	Air Flow	Air throw m		Surface	Tube volume	Defrost W				Fan Motors Ø mm x n°	Motor data	Noise Level dB(A)	Connections		Weight [kg]
	T.air 0C°/ T.ev -8C°	T.air -25C°/ T.ev -32C°	m³/h	-	Alfa Streamer	[m²]	[dm³]	E	EL	HG+E (tray)	FRH				5 mt	IN	
<b>Fin Spacing 10 mm / High speed Rotation</b>																	
ILBA501A10	6.097	5.441	8339	36	72	31.72	8.1	5600	2800	1400	450	500 X1	P=790W I=1,45A n=1330min-1 V=400V 4 poles	64	1"	1"1/2	97.70
ILBA501B10	7.356	6.527	8174	36	72	39.65	10.1	6300	3500	1400	450	500 X1		64	1"	1"1/2	101.7
ILBA501C10	8.495	7.496	4235	35	70	47.57	12.2	7000	3500	1400	450	500 X1		64	1"	1"1/2	106.7
ILBA502A10	14.73	12.14	16590	40	80	62.35	15.9	11200	5600	2800	900	500 X2		67	1"	1"1/2	199.4
ILBA502B10	17.73	14.57	16240	39	78	77.94	19.9	12600	7000	2800	900	500 X2		67	1"	1"1/2	209.4
ILBA502C10	20.42	16.73	15890	38	76	93.53	23.9	14000	7000	2800	900	500 X2		67	1"	1"1/2	217.4
ILBA503A10	22.35	17.73	24860	42	84	92.99	23.8	16800	8400	4200	1350	500 X3		69	1"	1"1/2	294.1
ILBA503B10	27	21.38	24330	41	82	116.2	29.7	18900	10500	4200	1350	500 X3		69	1"	1"1/2	310.1
ILBA503C10	31.22	24.69	23780	40	80	139.5	35.6	21000	10500	4200	1350	500 X3		69	1"	1"1/2	323.1
ILBA504A10	29.27	24.19	33150	43	86	123.6	31.6	21600	10800	5400	1800	500 X4		70	1"	2"	393.8
ILBA504B10	35.24	29.02	32440	42	84	154.5	39.5	24300	13500	5400	1800	500 X4		70	1"	2"	410.8
ILBA504C10	40.59	33.33	31710	42	84	185.4	47.4	27000	13500	5400	1800	500 X4		70	1"	2"	429.8
ILBA505A10	37.08	30.24	41420	44	88	154.3	39.4	27200	13600	6800	2250	500 X5		71	1"	2"	490.5
ILBA505B10	44.78	36.34	40520	43	86	192.8	49.3	30600	17000	6800	2250	500 X5		71	1"	2"	512.5
ILBA505C10	51.74	41.79	39610	43	86	231.4	59.1	34000	17000	6800	2250	500 X5		71	1"	2"	536.5
ILBA561B10	12.65	10.68	11440	44	-	61.87	15.8	8000	4000	1600	500	560 X1	P=1000W I=1,80A n=1220min-1 V=400V 4 poles	68	1"	2"	128.5
ILBA561C10	14.53	12.22	11190	43	-	74.25	19.0	9600	4800	1600	500	560 X1		68	1"	2"	135.5
ILBA561D10	16.2	13.56	10950	42	-	86.62	22.1	12000	6400	1600	500	560 X1		68	1"	2"	150.5
ILBA562B10	26.97	21.21	22790	48	-	121.9	31.2	16000	8000	3200	1000	560 X2		71	1"	2"	295.0
ILBA562C10	31.06	24.42	22280	47	-	146.3	37.4	19200	9600	3200	1000	560 X2		71	1"	2"	310.0
ILBA562D10	36.22	27.23	21760	46	-	170.7	43.6	24000	12800	3200	1000	560 X2		71	1"	2"	340.0
ILBA563B10	40.14	32.61	34160	50	-	182.0	46.5	24000	12000	4800	1500	560 X3		73	1"	2"	400.5
ILBA563C10	46.25	37.37	33400	49	-	218.4	55.8	28800	14400	4800	1500	560 X3		73	1"	2"	423.5
ILBA563D10	53.98	41.54	32610	48	-	254.8	65.1	36000	19200	4800	1500	560 X3		73	1"	2"	468.5
ILBA564B10	53.78	42.46	45510	51	-	242.1	61.9	32000	16000	6400	2000	560 X4		74	1"1/2	2"1/2	552.0
ILBA564C10	61.96	48.87	44490	51	-	290.5	74.2	38400	19200	6400	2000	560 X4		74	1"1/2	2"1/2	583.0
ILBA564D10	72.22	54.48	43440	50	-	338.9	86.6	48000	25600	6400	2000	560 X4		74	1"1/2	2"1/2	642.0
ILBA565B10	67.04	54.15	56890	53	-	302.1	77.2	40000	20000	8000	2500	560 X5		75	1"1/2	2"1/2	639.5
ILBA565C10	77.26	62.1	55660	52	-	362.6	92.7	48000	24000	8000	2500	560 X5		75	1"1/2	2"1/2	675.5
ILBA565D10	90.06	69.08	54290	51	-	423.0	108.1	60000	32000	8000	2500	560 X5		75	1"1/2	2"1/2	751.5
ILBA631B10	17.89	14.68	16790	56	112	77.34	19.8	9600	4800	1600	550	630 X1	P=2600W I=4,8A n=1310min-1 V=400V 4 poles	75	1"	2"	180.5
ILBA631C10	20.7	16.93	16540	55	110	92.81	23.7	12000	5600	1600	550	630 X1		75	1"	2"	189.5
ILBA631D10	23.24	18.95	16280	55	110	108.3	27.7	14400	7200	1600	550	630 X1		75	1"	2"	208.5
ILBA632B10	35.42	29.17	33530	60	120	152.4	38.9	19200	9600	3200	1100	630 X2		78	1"	2"	371.0
ILBA632C10	40.98	33.64	33000	60	120	182.9	46.7	24000	11200	3200	1100	630 X2		78	1"	2"	389.0
ILBA632D10	46.01	37.65	32480	59	118	213.4	54.5	28800	14400	3200	1100	630 X2		78	1"	2"	427.0
ILBA633B10	54.08	42.94	50240	63	126	227.5	58.1	28800	14400	4800	1650	630 X3		80	1"1/2	2"1/2	554.5
ILBA633C10	62.78	49.75	49440	62	124	273.0	69.8	36000	16800	4800	1650	630 X3		80	1"1/2	2"1/2	582.5
ILBA633D10	70.69	55.89	48640	61	122	318.5	81.4	43200	21600	4800	1650	630 X3		80	1"1/2	2"1/2	639.5
ILBA634B10	71.92	58.12	66980	65	130	302.6	77.3	38400	19200	6400	2200	630 X4		81	1"1/2	3"	733.0
ILBA634C10	83.48	67.15	65910	64	128	363.1	92.8	48000	22400	6400	2200	630 X4		81	1"1/2	3"	771.0
ILBA634D10	94.01	75.3	64840	63	126	423.6	108.3	57600	28800	6400	2200	630 X4		81	1"1/2	3"	847.0
ILBA635B10	89.83	70.08	83690	66	132	377.7	96.5	48000	24000	8000	2750	630 X5		82	1"1/2	3"	897.5
ILBA635C10	104.3	81.28	82350	65	130	453.2	115.8	60000	28000	8000	2750	630 X5		82	1"1/2	3"	943.5
ILBA635D10	117.4	91.5	81010	65	130	528.8	135.1	72000	36000	8000	2750	630 X5		82	1"1/2	3"	1039
ILBA801B10	29.12	22.94	31600	57	-	110.8	28.3	15000	8000	3000	700	800 X1	P=5100W I=8,8A n=1270min-1 V=400V 4 poles	81	1"	1"1/2	259.0
ILBA801C10	33.88	26.67	30850	56	-	133.0	34.0	18000	9000	3000	700	800 X1		81	1"	1"1/2	272.0
ILBA801D10	38.25	30.09	30110	56	-	155.2	39.6	21000	11000	3000	700	800 X1		81	1"	1"1/2	299.0
ILBA802B10	57.93	45.94	63060	63	-	219.0	55.9	28500	15200	5700	1400	800 X2		84	1"1/2	2"1/2	532.0
ILBA802C10	67.40	53.40	61520	62	-	262.7	67.1	34200	17100	5700	1400	800 X2		84	1"1/2	2"1/2	559.0
ILBA802D10	76.08	60.22	60040	61	-	306.5	78.3	39900	20900	5700	1400	800 X2		84	1"1/2	2"1/2	614.0
ILBA803B10	86.73	68.95	94520	66	-	327.1	83.6	43500	23200	8700	2100	800 X3		86	1"1/2	3"	797.0
ILBA803C10	100.9	80.13	92200	65	-	392.5	100.3	52200	26100	8700	2100	800 X3		86	1"1/2	3"	837.0
ILBA803D10	113.9	90.36	89960	64	-	457.9	117.0	60900	31900	8700	2100	800 X3		86	1"1/2	3"	920.0
ILBA804B10	115.5	91.96	126000	68	-	435.2	111.2	58500	31200	11700	2800	800 X4		87	1"1/2	3"	1053
ILBA804C10	134.4	106.9	122900	67	-	522.2	133.4	70200	35100	11700	2800	800 X4		87	1"1/2	3"	1108
ILBA804D10	149.9	111.9	119800	66	-	609.3	155.7	81900	42900	11700	2800	800 X4		87	1"1/2	3"	1218

# AirMax II HP

## Product Description

### Applications

This new Industrial Line of cubic coolers is specifically designed for high pressure (PS = 50 bar) in order to be used with one of the most environmental friendly refrigerant: the carbon dioxide. Typical use is to keep refrigerated fresh and frozen goods in medium to very large size of cold rooms. The range of capacity is quite wide: from 8 to 155 kW at -40°C with  $\Delta T=10K$ . Through the availability of different fan diameters (up to 800 mm), several fin spacing and a large list of options it is always possible to fit the best model for the required duty. With the new frame design and the improved features in the coil manufacturing, this industrial line allows the clients to install a reliable model to fit all the needs in the heavy application of the refrigeration business.

### Standard design

#### Coil

The heat exchanger is designed to offer the best performance in cooling for the considered application in order to minimize the refrigerant charge. The coil pitch is 60 x 60, with the tubes in line of 16 mm stainless steel material and aluminium fins. This new pattern is characterized by a large heat exchanger surface which ensures longer intervals between the defrost cycles. The only one inlet and outlet connection, with the combination of the different large fin spacing (8, 10 and 12 mm) and the several coil block modules, make the new line an innovative product range in the market.

#### Casing

All units use galvanized steel painted RAL 9002, while the drip tray is in aluminium painted.

The frame has been design in order to ensure an easy installation and maintenance. A large and deep drip tray permits a fast discharge of the water defrosting, with reliability of the bottom storage goods.

The supports have two different positions (flush mounted or space) to consent to install the water defrost cassette.

Structural parts are fastened with stainless steel bolts and screws.

Structures made of galvanized steel, with optimized length to permit uniform air suction in the coil.

### Benefits

- High energy efficiency class
- Plug-in installation
- Easy maintenance
- Correct design for any working conditions
- Silence installation
- Performance reliable
- Safety equipment
- Several options available

### Options

- Cabinet visible sheets pre-painted RAL9010
- Fan pre-wired to common terminal box



- Stainless steel drip tray
- Insulated drip tray
- Stainless steel casing
- Special powerful fan motors
- Air throw fan cowl
- AlfaStreamer
- Air sock adapter ring
- Fan ring heater
- Epoxy pre-coated fins
- Cataphoresys treatment
- Floor mounting supports
- Motor cabling
- Hot gas defrost (coil + drip tray) fully connected
- Hot gas defrost loose
- Electric defrost
- Light electric defrost
- Water defrost
- Combined defrost systems

**Fans**

Four different fan diameters available: 500, 560, 630 and 800 with three-phase motors (4/6 poles) 400V-50/60 Hz. The motors are with external rotor, constructed in accordance with VDE 0530/12.84. Protection class IP 54 according to DIN40050. Integrated thermal protection by thermo contacts, provide reliable protection against thermal overload. Sickle bladed die cast aluminium impeller and fan guard of steel cataphoresis black coated. All the standard fan motors can work down to -40°C; special lubrication is suitable upon request.

For air temperature lower than +20°C, the full load current (FLC) can be calculated by using the correction factor table. The overload protectors should have 20% margin to accommodate fan motor supplier variations.

T [°C]	20	10	0	-10	-15	-20	-25	-30
Fc	1	1,04	1,08	1,12	1,14	1,16	1,18	1,2

MODEL	Ca- capacity		Air Flow	Air throw m		Sur- face	Tube vol- ume	Defrost W				Fan Motors Ø mm x n°	Motor data	Noise Level dB(A)	Connections		Weight
	T.air 0C°/ T.ev -8C°	T.air -25C°/ T.ev -32C°		m³/h	-			Alfa Streamer	[m²]	[dm³]	E				EL	HG+E (tray)	
<b>Fin Spacing 6 mm / High speed Rotation</b>																	
ILRH501A6	9.142	7.718	8114	35	70	51.32	8.1	5600	2800	1400	450	500 x1	P=790W I=1.45A n=1330min-1 V=400V 4 poles	64	1"	1 1/2"	101.7
ILRH501B6	9.69	8.19	7905	35	70	64.15	10.1	6300	3500	1400	450	500 x1		64	1"	1 1/2"	106.7
ILRH501C6	12.32	10.24	7656	34	68	76.98	12.2	7000	3500	1400	450	500 x1		64	1"	1 1/2"	111.7
ILRH502A6	19.1	15.75	16150	39	78	100.9	15.9	11200	5600	2800	900	500 x2		67	1"	1 1/2"	208.4
ILRH502B6	21.41	17.96	15710	38	76	126.1	19.9	12600	7000	2800	900	500 x2		67	1"	1 1/2"	218.4
ILRH502C6	28.82	20.95	15200	37	74	151.3	23.9	14000	7000	2800	900	500 x2		67	1"	1 1/2"	228.4
ILRH503A6	28.24	23.63	24200	41	82	150.5	23.8	16800	8400	4200	1350	500 x3		69	1"	1 1/2"	308.1
ILRH503B6	33.47	27.81	23500	40	80	188.1	29.7	18900	10500	4200	1350	500 x3		69	1"	1 1/2"	324.1
ILRH503C6	37.83	31.32	22800	39	78	225.7	35.6	21000	10500	4200	1350	500 x3		69	1"	1 1/2"	338.1
ILRH504A6	38.09	31.46	32260	42	84	200.0	31.6	21600	10800	5400	1800	500 x4		70	1 1/2"	2"	411.8
ILRH504B6	42.55	35.69	31360	41	82	250.1	39.5	24300	13500	5400	1800	500 x4		70	1 1/2"	2"	430.8
ILRH504C6	48.32	40.24	30410	41	82	300.1	47.4	27000	13500	5400	1800	500 x4		70	1 1/2"	2"	449.8
ILRH505A6	46.1	38.81	40350	43	86	249.6	39.4	27200	13600	6800	2250	500 x5		71	1 1/2"	2"	513.5
ILRH505B6	54.65	45.66	39150	43	86	312.0	49.3	30600	17000	6800	2250	500 x5		71	1 1/2"	2"	536.5
ILRH505C6	62.01	51.43	37960	42	84	374.4	59.1	34000	17000	6800	2250	500 x5		71	1 1/2"	2"	561.5
ILRH561B6	15.57	13.05	11070	43	-	100.1	15.8	8000	4000	1600	500	560 x1		P=1000W I=1.80A n=1220min-1 V=400V 4 poles	68	1"	1 1/2"
ILRH561C6	17.65	14.68	10740	42	-	120.1	19.0	9600	4800	1600	500	560 x1	68		1"	1 1/2"	141.5
ILRH561D6	20.15	16.03	10420	41	-	140.2	22.1	12000	6400	1600	500	560 x1	68		1"	1 1/2"	157.5
ILRH562B6	33.46	27.67	22020	46	-	197.3	31.2	16000	8000	3200	1000	560 x2	71		1"	1 1/2"	309.0
ILRH562C6	39.38	31.03	21340	45	-	236.8	37.4	19200	9600	3200	1000	560 x2	71		1"	1 1/2"	325.0
ILRH562D6	43.03	33.79	20720	45	-	276.2	43.6	24000	12800	3200	1000	560 x2	71		1"	1 1/2"	356.0
ILRH563B6	48.7	40.59	33010	49	-	294.5	46.5	24000	12000	4800	1500	560 x3	73		1 1/2"	2"	419.5
ILRH563C6	54.98	45.53	32000	48	-	353.4	55.8	28800	14400	4800	1500	560 x3	73		1 1/2"	2"	444.5
ILRH563D6	62.73	49.59	31030	47	-	412.3	65.1	36000	19200	4800	1500	560 x3	73		1 1/2"	2"	491.5
ILRH564B6	66.64	55.15	43950	50	-	391.7	61.9	32000	16000	6400	2000	560 x4	74		2"	2 1/2"	578.0
ILRH564C6	78.43	61.86	42590	49	-	470.1	74.2	38400	19200	6400	2000	560 x4	74		2"	2 1/2"	610.0
ILRH564D6	85.7	67.34	41330	48	-	548.4	86.6	48000	25600	6400	2000	560 x4	74		2"	2 1/2"	673.0
ILRH565B6	84.18	69	54900	52	-	488.9	77.2	40000	20000	8000	2500	560 x5	75		2 1/2"	3"	668.5
ILRH565C6	98.96	77.46	53200	51	-	586.7	92.7	48000	24000	8000	2500	560 x5	75		2 1/2"	3"	707.5
ILRH565D6	108.2	84.39	51620	50	-	684.5	108.1	60000	32000	8000	2500	560 x5	75		2 1/2"	3"	787.5
ILRH631B6	21.7	18.21	16410	55	110	125.1	19.8	9600	4800	1600	550	630 x1	P=2600W I=4.8A n=1310min-1 V=400V 4 poles		75	1 1/2"	2"
ILRH631C6	24.79	20.65	16080	54	108	150.2	23.7	12000	5600	1600	550	630 x1		75	1 1/2"	2"	198.5
ILRH631D6	27.41	22.75	15750	53	106	175.2	27.7	14400	7200	1600	550	630 x1		75	1 1/2"	2"	218.5
ILRH632B6	45.59	37.43	32700	59	118	246.6	38.9	19200	9600	3200	1100	630 x2		78	1 1/2"	2"	389.0
ILRH632C6	51.82	42.49	32010	58	116	296.0	46.7	24000	11200	3200	1100	630 x2		78	1 1/2"	2"	408.0
ILRH632D6	60.04	46.77	31330	57	114	345.3	54.5	28800	14400	3200	1100	630 x2		78	1 1/2"	2"	448.0
ILRH633B6	67.28	55.99	49040	62	124	368.2	58.1	28800	14400	4800	1650	630 x3		80	2"	2 1/2"	582.5
ILRH633C6	76.8	63.47	48000	61	122	441.8	69.8	36000	16800	4800	1650	630 x3		80	2"	2 1/2"	611.5
ILRH633D6	88.61	69.86	46960	60	120	515.4	81.4	43200	21600	4800	1650	630 x3		80	2"	2 1/2"	671.5
ILRH634B6	90.95	74.79	65330	64	128	489.7	77.3	38400	19200	6400	2200	630 x4		81	2 1/2"	3"	769.0
ILRH634C6	103.5	84.88	63930	63	126	587.6	92.8	48000	22400	6400	2200	630 x4		81	2 1/2"	3"	809.0
ILRH634D6	119.8	93.42	62560	62	124	685.5	108.3	57600	28800	6400	2200	630 x4		81	2 1/2"	3"	889.0
ILRH635B6	112.8	93.53	81660	65	130	611.2	96.5	48000	24000	8000	2750	630 x5		82	2 1/2"	3"	942.5
ILRH635C6	128.7	106	79920	64	128	733.4	115.8	60000	28000	8000	2750	630 x5		82	2 1/2"	3"	990.5
ILRH635D6	148.4	116.7	78190	63	126	855.6	135.1	72000	36000	8000	2750	630 x5		82	2 1/2"	3"	1090
ILRH801B6	36.19	30.29	30490	56	-	179.3	28.3	15000	8000	3000	700	800 x1		P=5100W I=8.8A n=1270min-1 V=400 V 4 poles	81	1"	1 1/2"
ILRH801C6	41.44	34.48	29550	55	-	215.2	34.0	18000	9000	3000	700	800 x1	81		1"	1 1/2"	286.0
ILRH801D6	46.05	38.10	28660	54	-	251.1	39.6	21000	11000	3000	700	800 x1	81		1"	1 1/2"	314.0
ILRH802B6	71.83	60.21	60800	61	-	354.3	55.9	28500	15200	5700	1400	800 x2	84		2"	2 1/2"	559.0
ILRH802C6	82.26	68.54	58890	60	-	425.2	67.1	34200	17100	5700	1400	800 x2	84		2"	2 1/2"	587.0
ILRH802D6	91.40	75.72	57100	59	-	496.0	78.3	39900	20900	5700	1400	800 x2	84		2"	2 1/2"	645.0
ILRH803B6	107.5	90.13	91110	65	-	529.3	83.6	43500	23200	8700	2100	800 x3	86		2 1/2"	3"	837.0
ILRH803C6	123.1	102.6	88240	63	-	635.1	100.3	52200	26100	8700	2100	800 x3	86		2 1/2"	3"	879.0
ILRH803D6	138.9	113.1	85420	62	-	741.0	117.0	60900	31900	8700	2100	800 x3	86		2 1/2"	3"	967.0
ILRH804B6	145.5	120.5	121300	67	-	704.2	111.2	58500	31200	11700	2800	800 x4	87		2 1/2"	3"	1105
ILRH804C6	166.7	137.3	117500	66	-	845.1	133.4	70200	35100	11700	2800	800 x4	87		2 1/2"	3"	1163
ILRH804D6	185.3	151.8	113900	64	-	985.9	155.7	81900	42900	11700	2800	800 x4	87		2 1/2"	3"	1279



MODEL	Ca- pacity	Ca- pacity	Air Flow	Air throw m		Sur- face	Tube vol- ume	Defrost W				Fan Motors Ø mm x n°	Motor data	Noise Level dB(A)	Connections		Weight
	T.air 0C°/ T.ev -8C°	T.air -25C°/ T.ev -32C°	m³/h	-	Alfa Streamer	[m²]	[dm³]	E	EL	HG+E (tray)	FRH				5 mt	IN	
<b>Fin Spacing 10 mm / High speed Rotation</b>																	
ILBH501A10	6.893	5.806	8325	36	72	31.72	8.1	5600	2800	1400	450	500 x1	P=790W I=1.45A n=1330min-1 V=400V 4 poles	64	1"	1 1/2"	97.70
ILBH501B10	7.366	5.969	8174	36	72	39.65	10.1	6300	3500	1400	450	500 x1		64	1"	1 1/2"	101.7
ILBH501C10	9.644	8.036	7983	35	70	47.57	12.2	7000	3500	1400	450	500 x1		64	1"	1 1/2"	106.7
ILBH502A10	14.58	12.09	16590	40	80	62.35	15.9	11200	5600	2800	900	500 x2		67	1"	1 1/2"	199.4
ILBH502B10	16.45	13.79	16270	39	78	77.94	19.9	12600	7000	2800	900	500 x2		67	1"	1 1/2"	209.4
ILBH502C10	20.37	16.73	15880	38	76	93.53	23.9	14000	7000	2800	900	500 x2		67	1"	1 1/2"	217.4
ILBH503A10	21.39	17.91	24880	42	84	92.99	23.8	16800	8400	4200	1350	500 x3		69	1"	1 1/2"	294.1
ILBH503B10	25.84	21.52	24350	41	82	116.2	29.7	18900	10500	4200	1350	500 x3		69	1"	1 1/2"	310.1
ILBH503C10	29.88	24.76	23810	40	80	139.5	35.6	21000	10500	4200	1350	500 x3		69	1"	1 1/2"	323.1
ILBH504A10	29.05	24.1	33150	43	86	123.6	31.6	21600	10800	5400	1800	500 x4		70	1 1/2"	2"	393.8
ILBH504B10	32.67	27.41	32490	42	84	154.5	39.5	24300	13500	5400	1800	500 x4		70	1 1/2"	2"	410.8
ILBH504C10	37.82	31.55	31760	42	84	185.4	47.4	27000	13500	5400	1800	500 x4		70	1 1/2"	2"	429.8
ILBH505A10	34.81	29.26	41460	44	88	154.3	39.4	27200	13600	6800	2250	500 x5		71	1 1/2"	2"	490.5
ILBH505B10	42.07	35.17	40570	43	86	192.8	49.3	30600	17000	6800	2250	500 x5		71	1 1/2"	2"	512.5
ILBH505C10	48.65	40.47	39660	43	86	231.4	59.1	34000	17000	6800	2250	500 x5		71	1 1/2"	2"	536.5
ILBH561B10	11.96	10.03	11450	44	-	61.87	15.8	8000	4000	1600	500	560 x1	P=1000W I=1.80A n=1220min-1 V=400V 4 poles	68	1"	1 1/2"	128.5
ILBH561C10	13.82	11.52	11210	43	-	74.25	19.0	9600	4800	1600	500	560 x1		68	1"	1 1/2"	135.5
ILBH561D10	15.49	12.85	10960	42	-	86.62	22.1	12000	6400	1600	500	560 x1		68	1"	1 1/2"	150.5
ILBH562B10	25.93	21.52	22810	48	-	121.9	31.2	16000	8000	3200	1000	560 x2		71	1"	1 1/2"	295.0
ILBH562C10	29.9	24.68	22300	47	-	146.3	37.4	19200	9600	3200	1000	560 x2		71	1"	1 1/2"	310.0
ILBH562D10	33.34	27.47	21800	46	-	170.7	43.6	24000	12800	3200	1000	560 x2		71	1"	1 1/2"	340.0
ILBH563B10	37.56	31.35	34200	50	-	182.0	46.5	24000	12000	4800	1500	560 x3		73	1 1/2"	2"	400.5
ILBH563C10	43.33	35.97	33440	49	-	218.4	55.8	28800	14400	4800	1500	560 x3		73	1 1/2"	2"	423.5
ILBH563D10	48.49	40.04	32680	48	-	254.8	65.1	36000	19200	4800	1500	560 x3		73	1 1/2"	2"	468.5
ILBH564B10	51.61	42.86	45560	51	-	242.1	61.9	32000	16000	6400	2000	560 x4		74	2"	2 1/2"	552.0
ILBH564C10	59.51	49.16	44540	51	-	290.5	74.2	38400	19200	6400	2000	560 x4		74	2"	2 1/2"	583.0
ILBH564D10	66.41	54.7	43510	50	-	338.9	86.6	48000	25600	6400	2000	560 x4		74	2"	2 1/2"	642.0
ILBH565B10	65.47	54.05	56910	53	-	302.1	77.2	40000	20000	8000	2500	560 x5		75	2 1/2"	3"	639.5
ILBH565C10	75.48	62.01	55630	52	-	362.6	92.7	48000	24000	8000	2500	560 x5		75	2 1/2"	3"	675.5
ILBH565D10	84.55	69.02	54340	51	-	423.0	108.1	60000	32000	8000	2500	560 x5		75	2 1/2"	3"	751.5
ILBH631B10	16.57	13.9	16810	56	112	77.34	19.8	9600	4800	1600	550	630 x1	P=2600W I=4.8A n=1310min-1 V=400V 4 poles	75	1 1/2"	2"	180.5
ILBH631C10	19.26	16.07	16560	55	110	108.3	27.7	12000	5600	1600	550	630 x1		75	1 1/2"	2"	208.5
ILBH631D10	21.71	18.03	16300	55	110	108.3	27.7	14400	7200	1600	550	630 x1		75	1 1/2"	2"	208.5
ILBH632B10	35.22	29.11	33530	60	120	152.4	38.9	19200	9600	3200	1100	630 x2		78	1 1/2"	2"	371.0
ILBH632C10	40.9	33.64	33000	60	120	182.9	46.7	24000	11200	3200	1100	630 x2		78	1 1/2"	2"	389.0
ILBH632D10	46.08	37.73	32470	59	118	213.4	54.5	28800	14400	3200	1100	630 x2		78	1 1/2"	2"	427.0
ILBH633B10	51.63	43.05	50280	63	126	227.5	58.1	28800	14400	4800	1650	630 x3		80	2"	2 1/2"	554.5
ILBH633C10	59.94	49.73	49490	62	124	273.0	69.8	36000	16800	4800	1650	630 x3		80	2"	2 1/2"	582.5
ILBH633D10	67.54	55.76	48690	61	122	318.5	81.4	43200	21600	4800	1650	630 x3		80	2"	2 1/2"	639.5
ILBH634B10	70.19	58.07	67000	65	130	302.6	77.3	38400	19200	6400	2200	630 x4		81	2 1/2"	3"	733.0
ILBH634C10	81.5	67.11	65930	64	128	363.1	92.8	48000	22400	6400	2200	630 x4		81	2 1/2"	3"	771.0
ILBH634D10	91.82	75.27	64860	63	126	423.6	108.3	57600	28800	6400	2200	630 x4		81	2 1/2"	3"	847.0
ILBH635B10	86.66	72.11	83750	66	132	377.7	96.5	48000	24000	8000	2750	630 x5		82	2 1/2"	3"	897.5
ILBH635C10	100.6	83.3	82420	65	130	453.2	115.8	60000	28000	8000	2750	630 x5		82	2 1/2"	3"	943.5
ILBH635D10	113.4	93.4	81080	65	130	528.8	135.1	72000	36000	8000	2750	630 x5		82	2 1/2"	3"	1039
ILBH801B10	27.83	23.30	31650	57	-	110.8	28.3	15000	8000	3000	700	800 x1	P=5100W I=8.8A n=1270min-1 V=400V 4 poles	81	1"	1 1/2"	259.0
ILBH801C10	32.38	26.99	30890	56	-	133.0	34.0	18000	9000	3000	700	800 x1		81	1"	1 1/2"	272.0
ILBH801D10	36.55	30.34	30160	56	-	155.2	39.6	21000	11000	3000	700	800 x1		81	1"	1 1/2"	299.0
ILBH802B10	55.19	46.25	63150	63	-	219.0	55.9	28500	15200	5700	1400	800 x2		84	2"	2 1/2"	532.0
ILBH802C10	64.21	53.58	61620	62	-	262.7	67.1	34200	17100	5700	1400	800 x2		84	2"	2 1/2"	559.0
ILBH802D10	72.48	60.23	60140	61	-	306.5	78.3	39900	20900	5700	1400	800 x2		84	2"	2 1/2"	614.0
ILBH803B10	82.55	69.21	94660	66	-	327.1	83.6	43500	23200	8700	2100	800 x3		86	2 1/2"	3"	797.0
ILBH803C10	96.04	80.17	92350	65	-	392.5	100.3	52200	26100	8700	2100	800 x3		86	2 1/2"	3"	837.0
ILBH803D10	111.4	91.35	90010	64	-	457.9	117.0	60900	31900	8700	2100	800 x3		86	2 1/2"	3"	920.0
ILBH804B10	112.5	93.47	126100	68	-	435.2	111.2	58500	31200	11700	2800	800 x4		87	2 1/2"	3"	1053
ILBH804C10	130.9	108.3	123000	67	-	522.2	133.4	70200	35100	11700	2800	800 x4		87	2 1/2"	3"	1108
ILBH804D10	147.7	121.8	120000	66	-	609.3	155.7	81900	42900	11700	2800	800 x4		87	2 1/2"	3"	1218

# AirMax II

## Drawings

DX - 5000

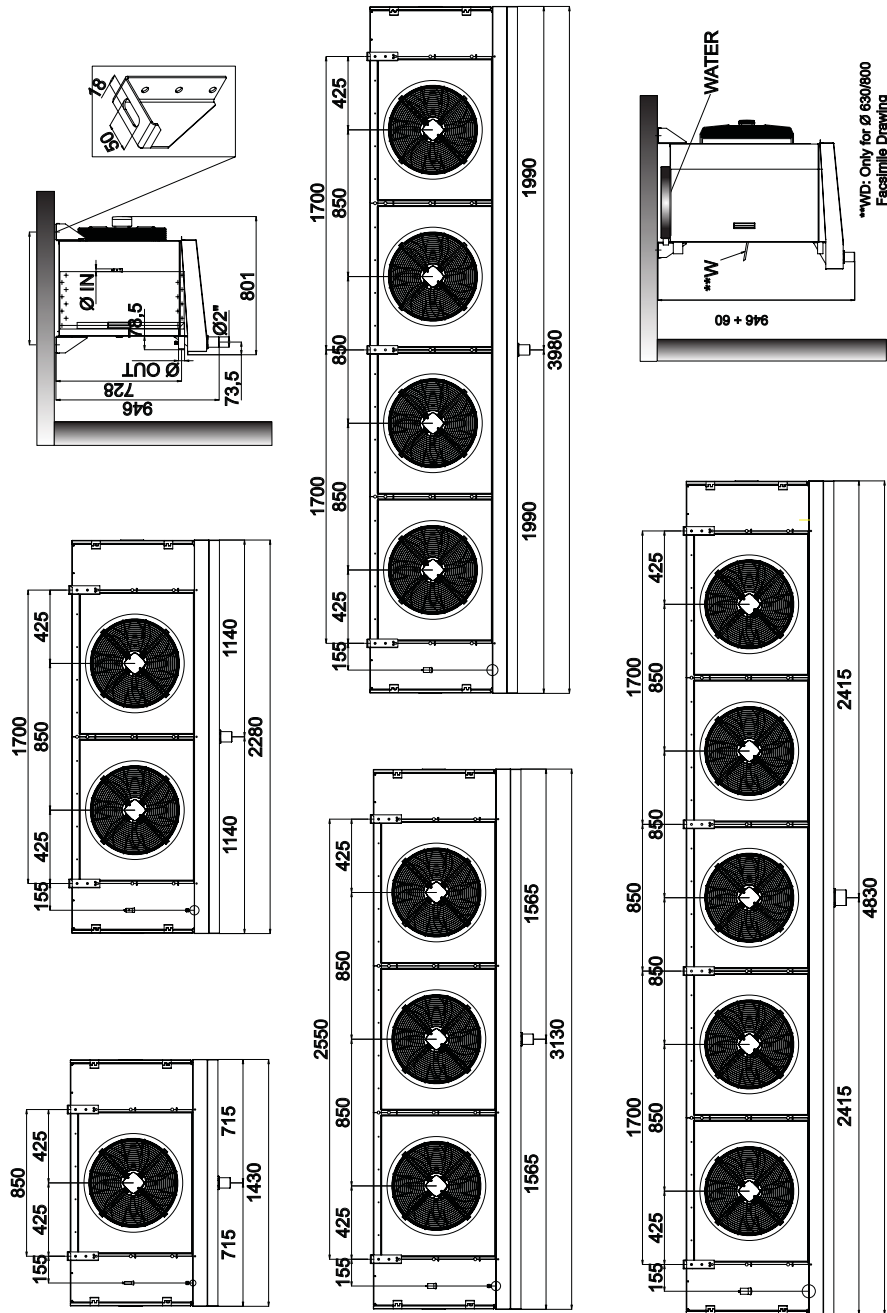



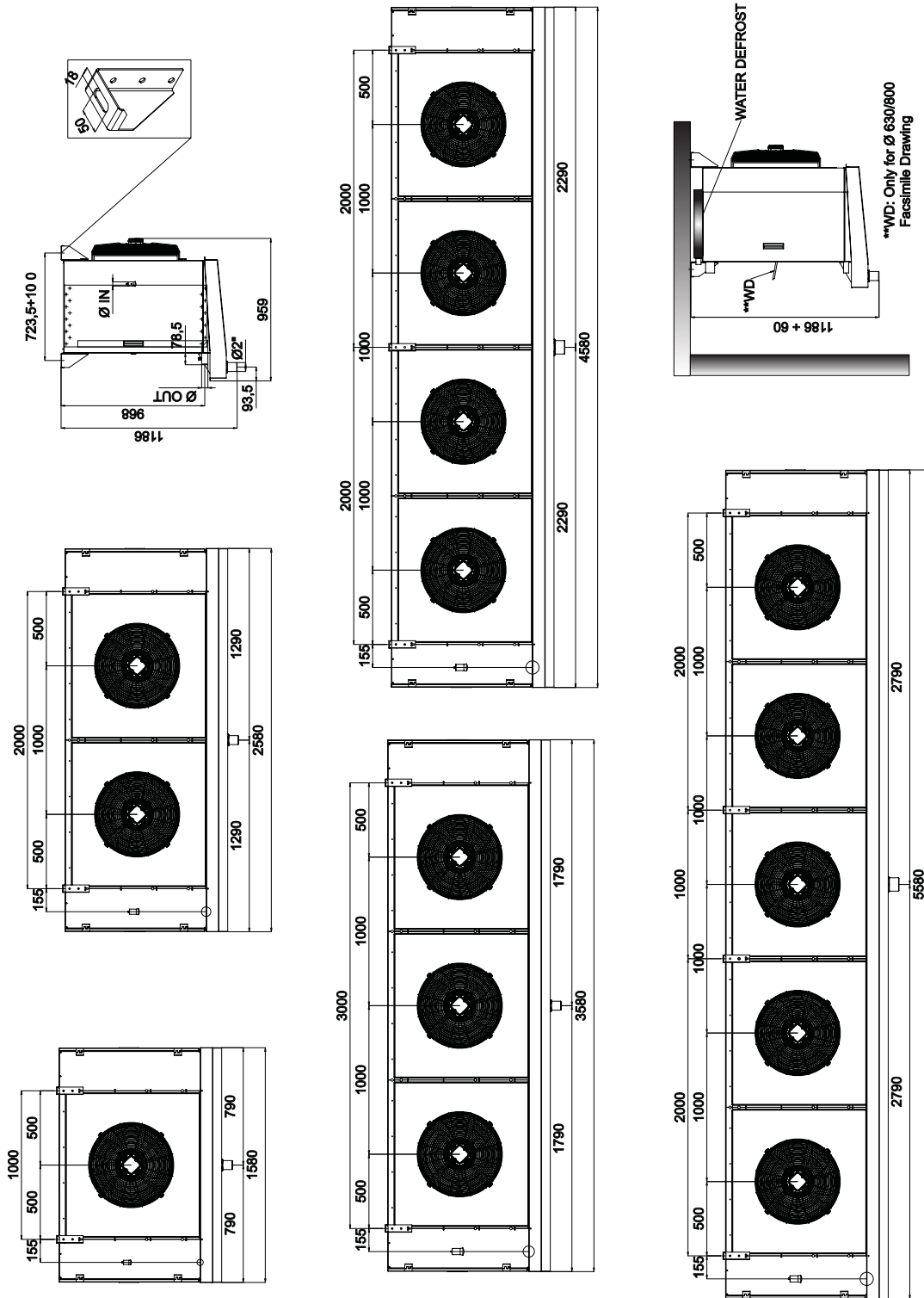

\*\*WD: Only for Ø 630/800 Facsimile Drawing

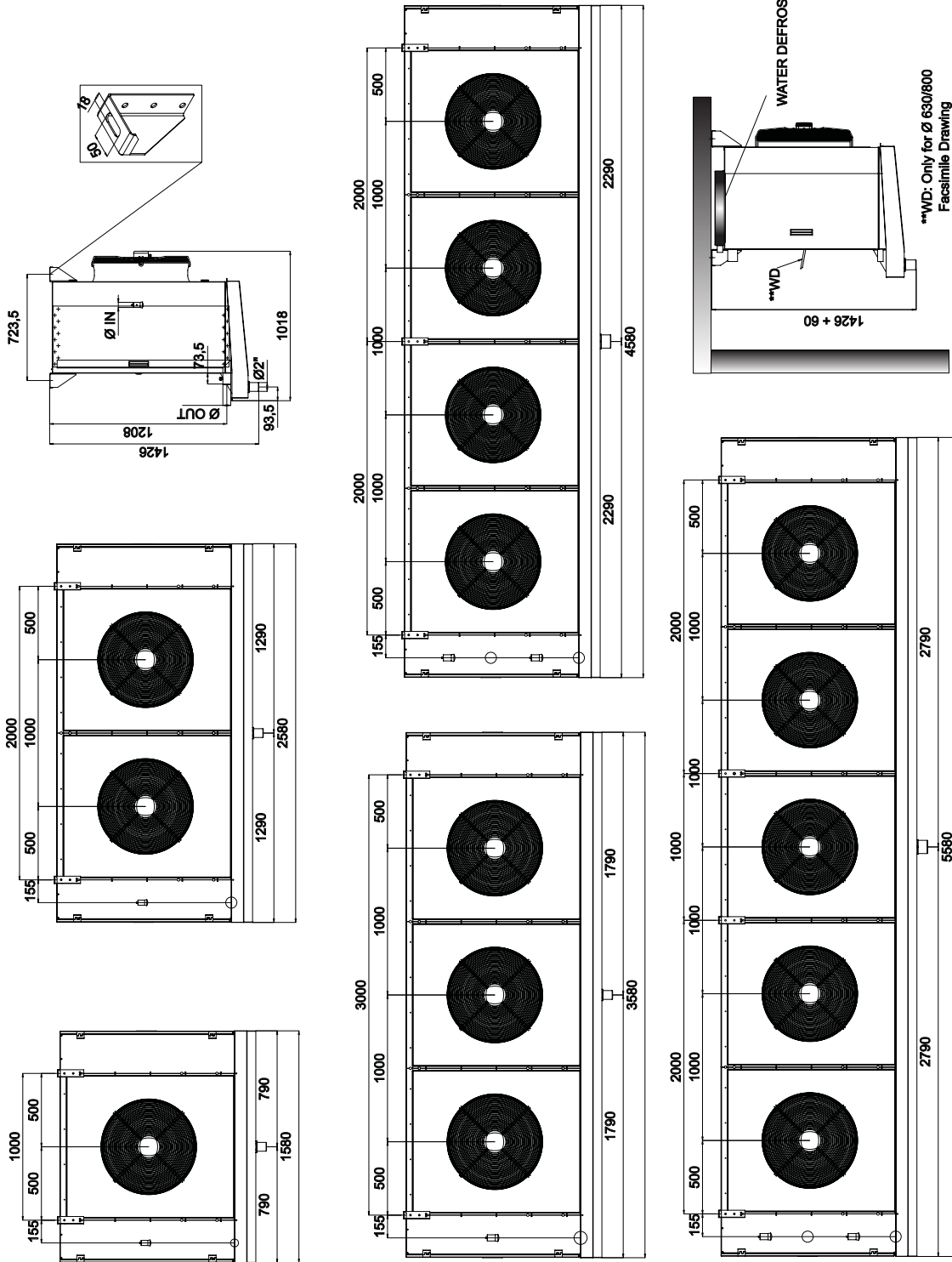

\*\*WD: Only for Ø 630/800 Facsimile Drawing

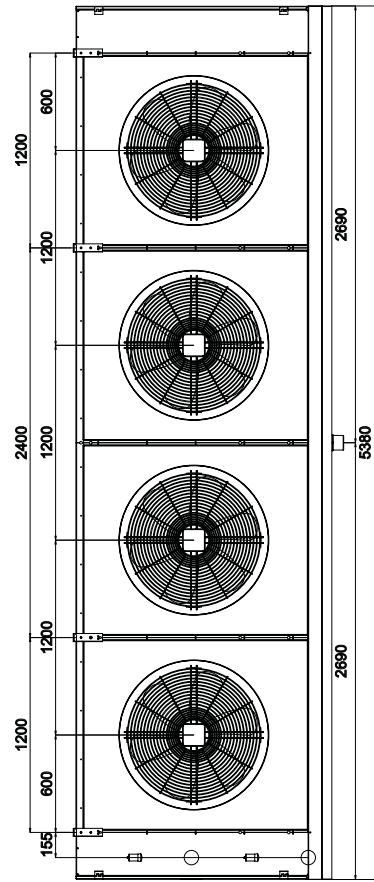
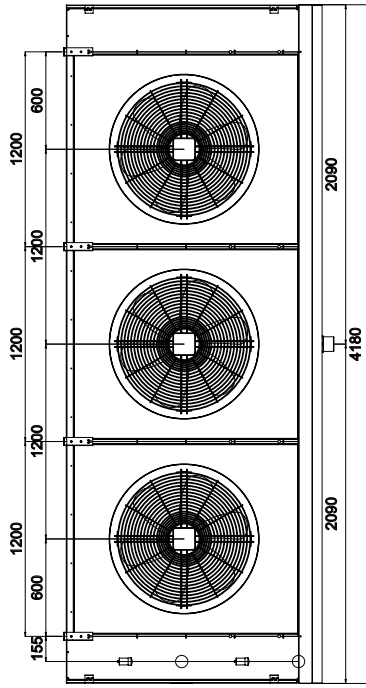
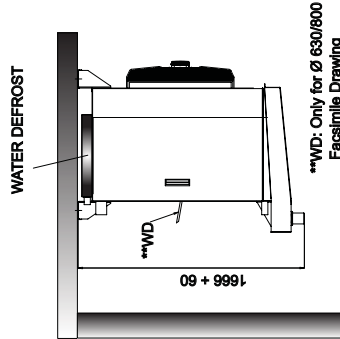
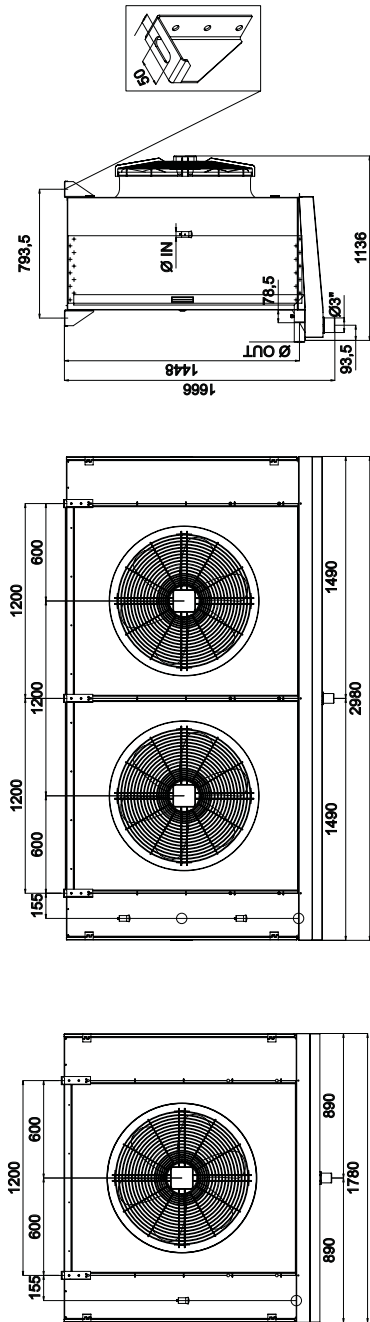

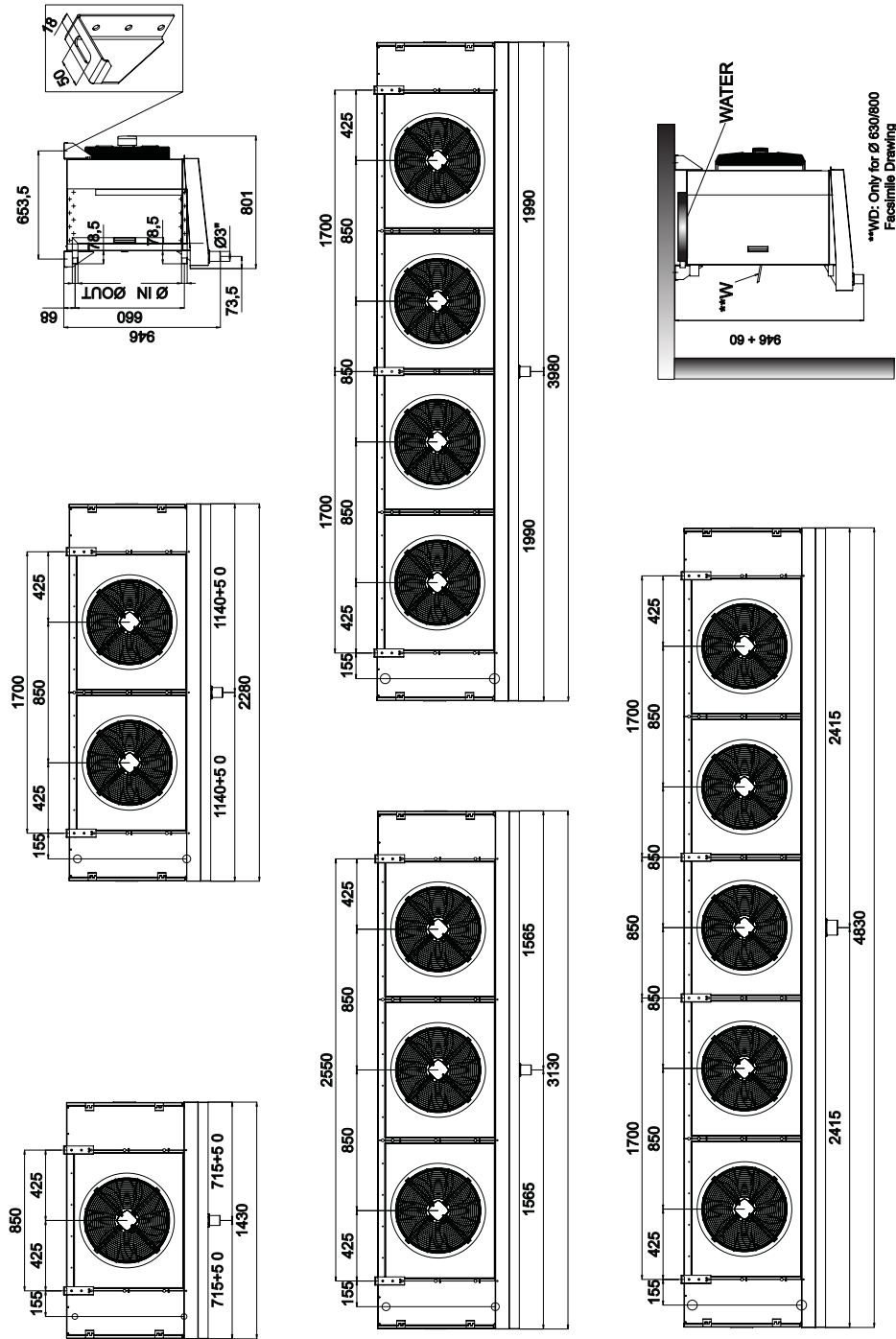

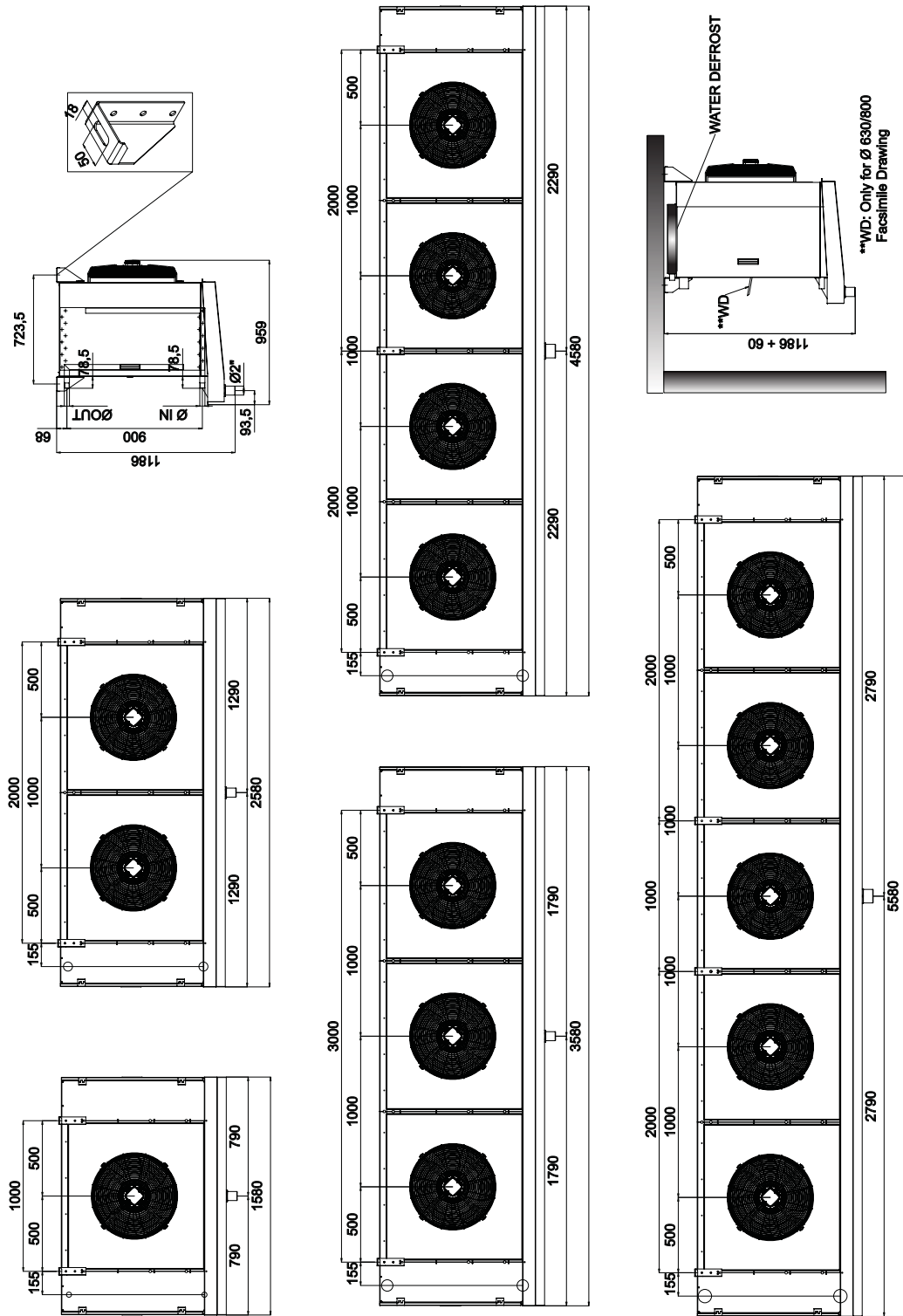

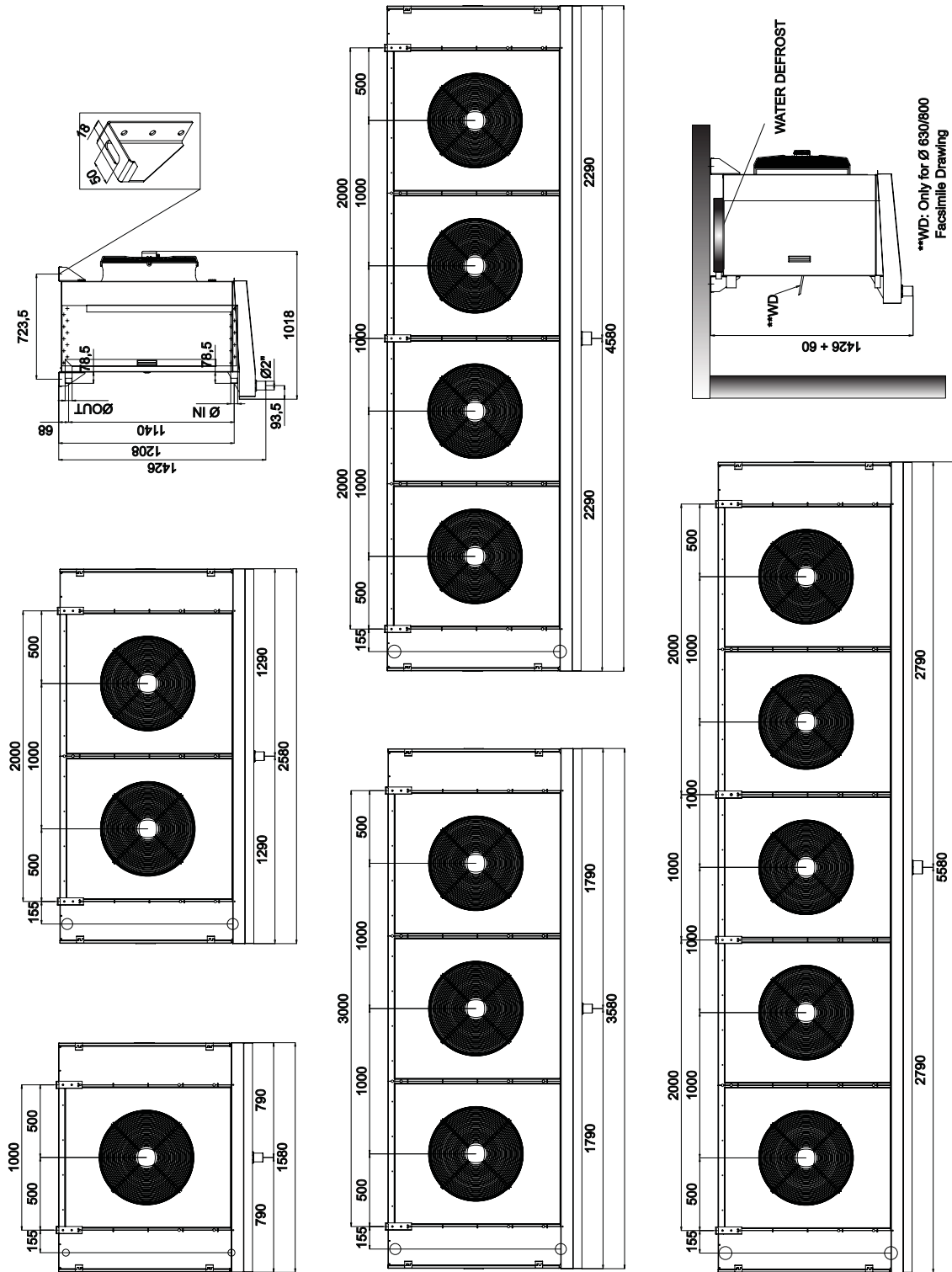

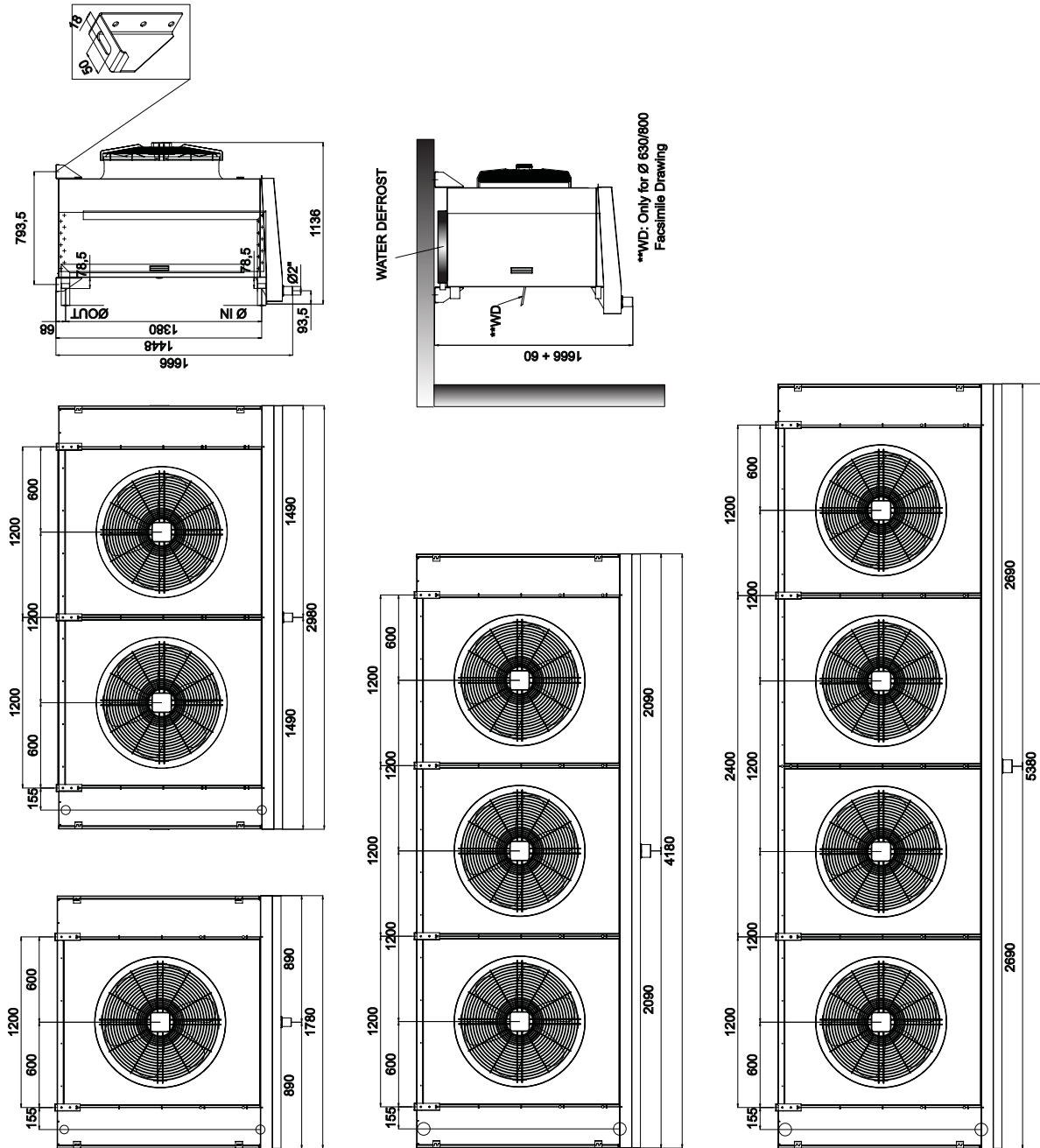

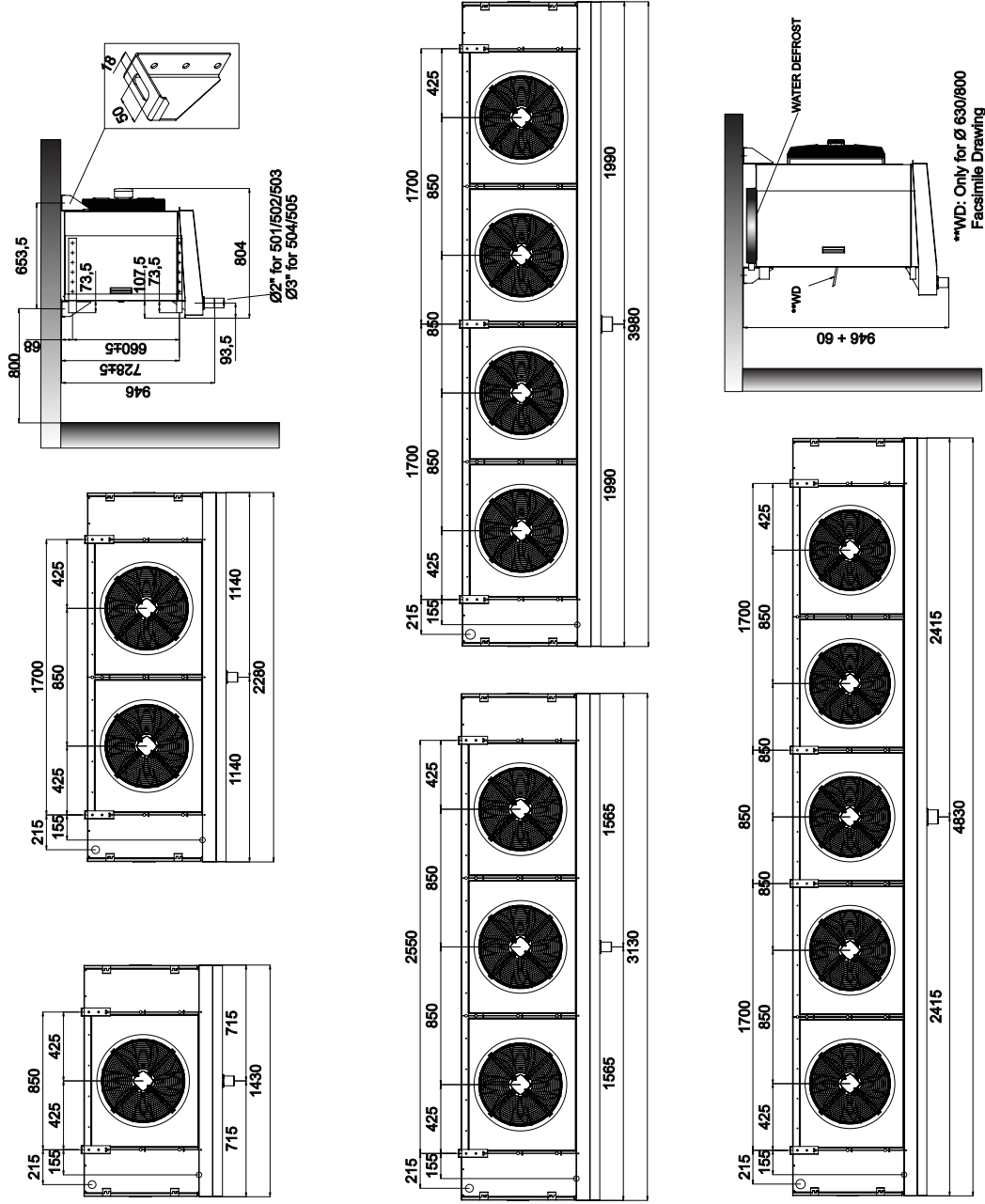



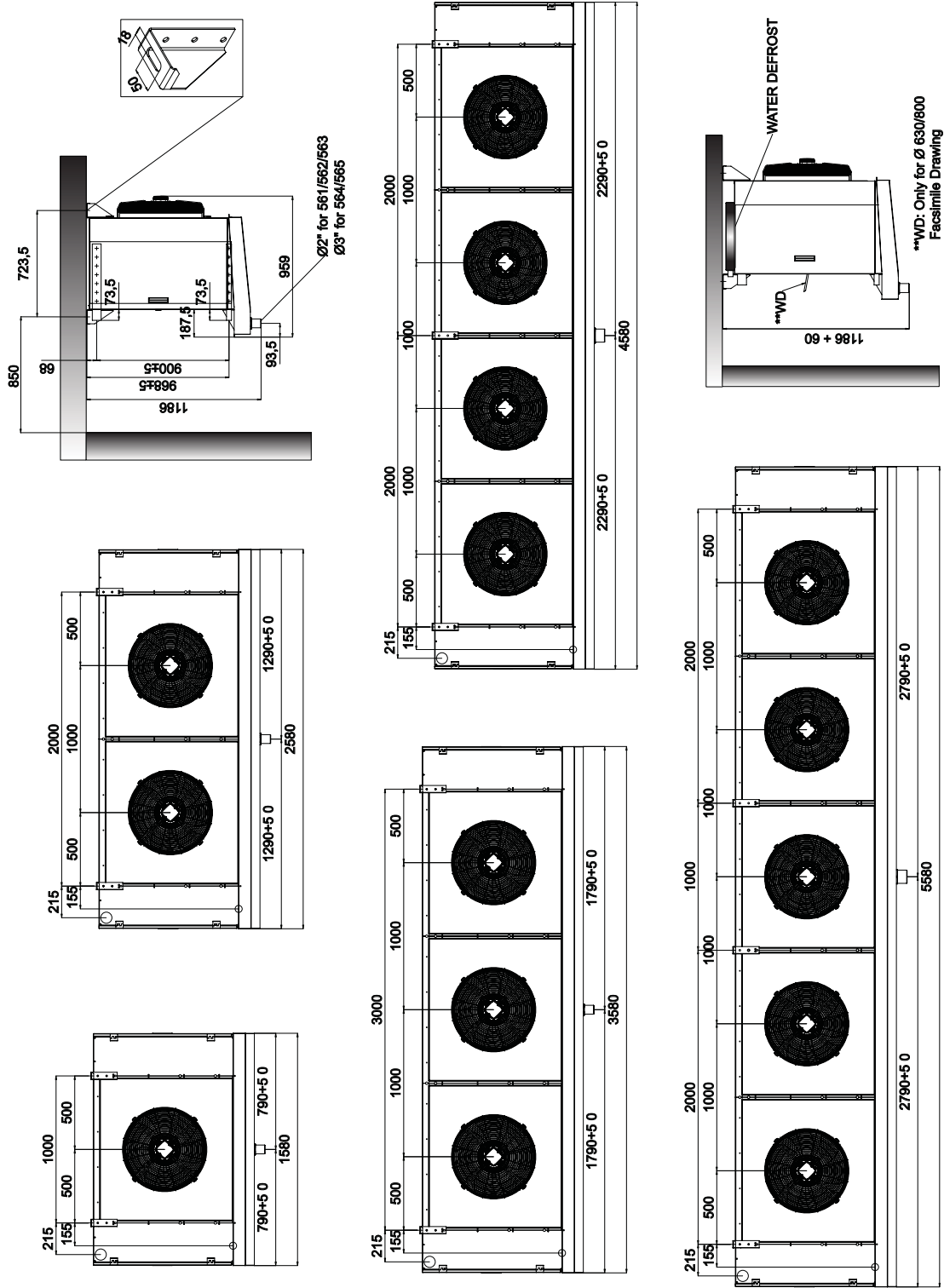

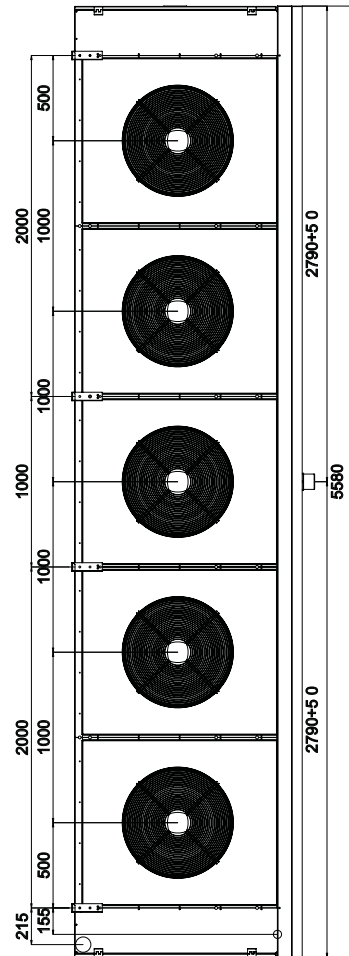
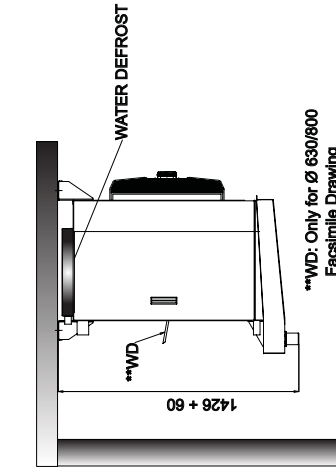
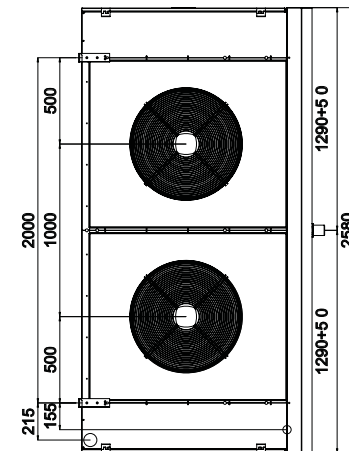
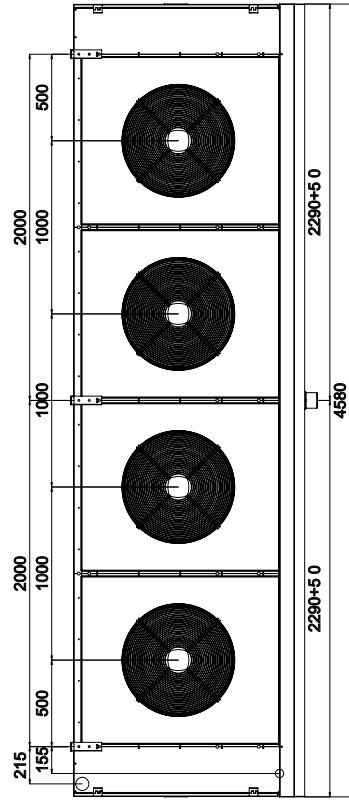
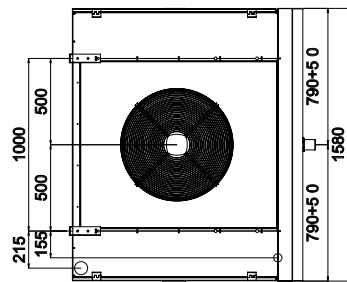
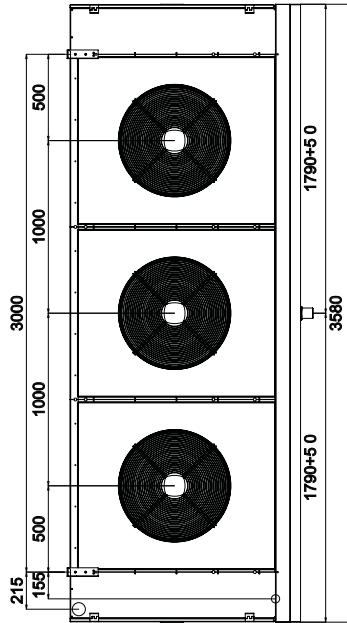
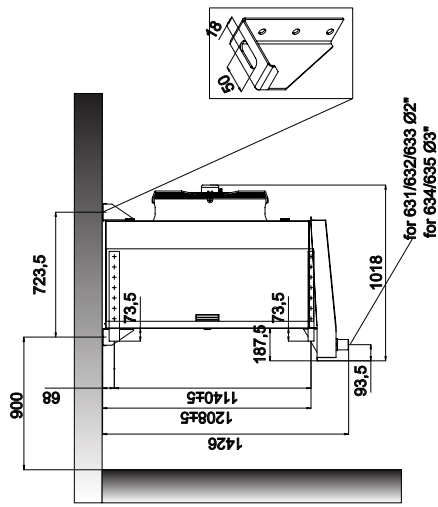

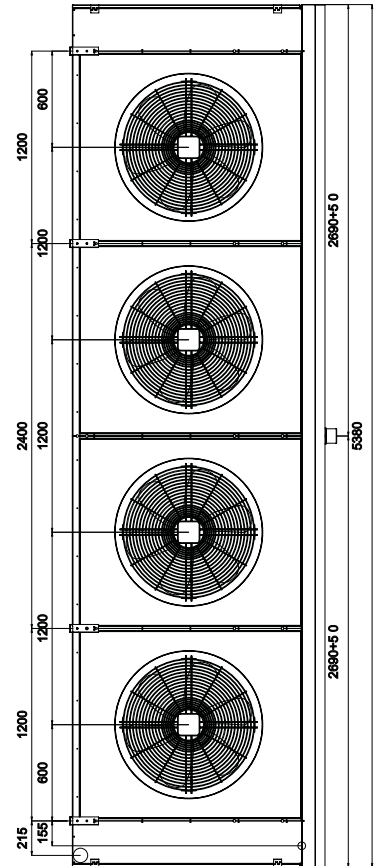
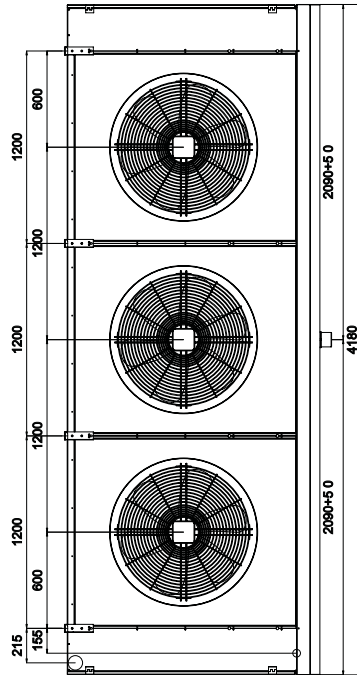
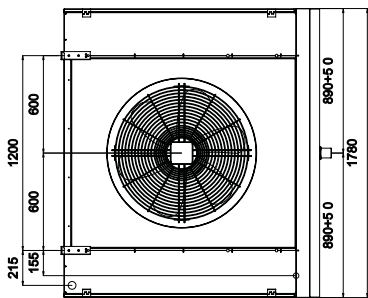
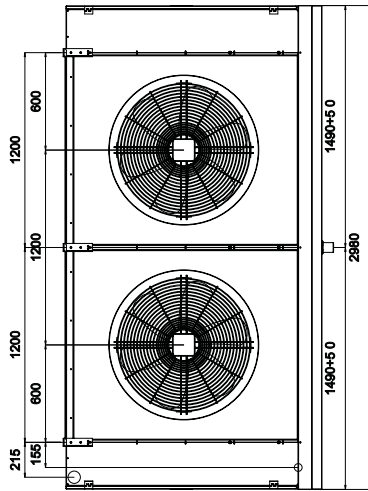
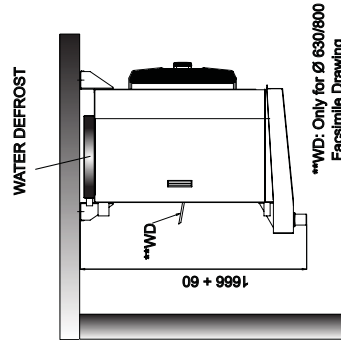
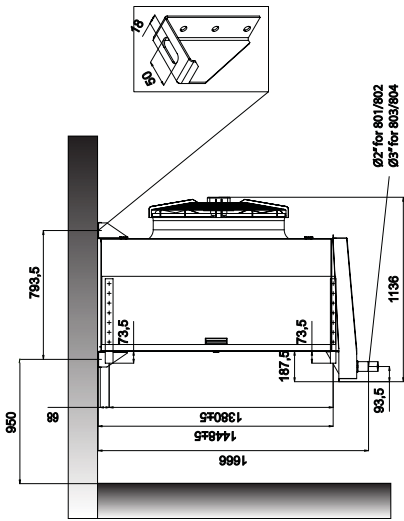

## AirMaxII

## Options

## Fan prewired to common Terminal Box

Fan motor prewired to common terminal box junction box, IP55, in painted galvanized steel material. See Electrical Data page.

**Model:**  
**ALL APPLICATIONS**  
All Models

## Local Safety switch wired

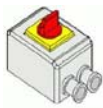

Local safety switch and cabling for each electric fan motor. Plastic covering box, IP66, nominal current 16A – 3 phases, insulated voltage 600V. Reference and standard CE/UL/CSA. Per each.

**Model:**  
**ALL APPLICATIONS**  
All Models

## Fan motors



6 poles, 230V/1Ph - 50/60Hz  
4 poles, 230V/1Ph - 50/60Hz  
6 poles, 400 V/3ph - 50Hz

**Model:**  
**ALL APPLICATIONS**  
230V/1Ph for Ø  
500  
400V/3Ph for Ø  
560/630/800

## Fan ring heater (FRH)

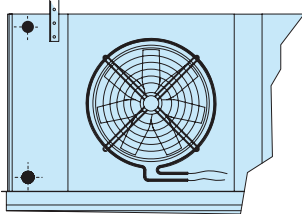

**Application:**  
To avoid the freezing-up of the fan blades at the collar under extremely humid conditions during defrost in cooling or freezing rooms.

**Supply conditions:**  
Electric heater made in SSI, fixing spring stainless steel, connection box.

**Model:**  
**ALL APPLICATIONS**  
All Models

## Air sock adapter ring

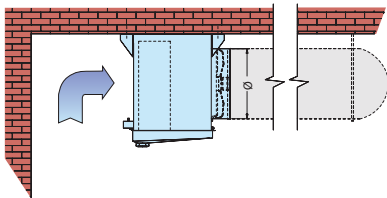



**Applications:** flower and fruit storage areas, supermarket, bakeries, meat and meat-processing operations. Price per unit cooler.

**Benefits:** Equal cooling effect without draught Equal temperature distribution Comfort in cold working areas.

The sock reduces the airflow and capacity. Please contact Alfa Laval for design and unit section.

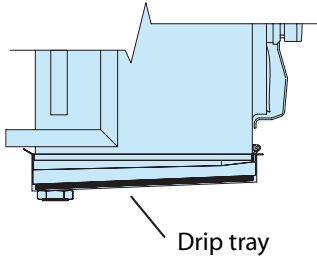
**Model:**  
**ALL APPLICATIONS**  
All Models

AlfaStreamer		
	<p>Increase of the axial air flow speed by deviation of centrifugal and circular flow components.                  Increased air throw for refrigeration applications.                  Applications: cold stores, working room</p>	<p><b>Model:</b>                  ALL APPLICATIONS                  Ø 500 mm                  Ø 630 mm                  Ø 800 mm (for 6poles)</p>
Insulated drip tray		
 <p style="text-align: center;">Drip tray</p>	<p><b>Construction:</b> Sandwich manufactured with two aluminium plate and 12 mm Polyethylene insulation in between.  <b>Features:</b> The insulation avoids water condensing on the bottom side of the drip-tray and reduces the transfer of the defrost heat into the cold room. It can be combined with Electric defrost or Hg defrost.  <b>Applications:</b> Room temperatures below -10°C, Food processing room.</p>	<p><b>Model:</b>                  ALL APPLICATIONS                  All Models</p>
Cable electrical heater		
	<p>Applications:                  During the defrosting time is recommend to have the drain pipeline heated to prevent the ice formation in the pipes.                  The flexible electrical heater can be easily placed inside of the pipe                  Power: 70W.                  Voltage: 230V</p>	<p><b>Model:</b>                  ALL APPLICATIONS                  All Models</p>
Cabinet all parts of stainless steel		
	<p>External casework component in stainless steel AISI 304.                  Application Use: Corrosion Preventive in Miscellaneous page.</p>	<p><b>Model:</b>                  ALL APPLICATIONS                  All Models</p>
Coil Treatment/Material		
	<p><b>Pre-coated fins:</b> Epoxy pre-painted aluminium fins.  <b>Cataphoresis treatment:</b> Electrolytic process where the coil is put in a paint bath where the coil is acting as a cathode and it is covered completely by an epoxidic paint that gives a very good protection against corrosion. Recommended for alkali or salty atmospheres.                  Application Use: Corrosion Preventive in Miscellaneous page.</p>	<p><b>Model:</b>                  ALL APPLICATIONS                  All Models</p>
Special fin spacing		
	<p>Different fin spacings are available for the series GL, RL,BL. Air flow and air throw are influenced by the variations of it.</p>	<p><b>Model:</b>                  ALL APPLICATIONS                  All Models</p>
Carbon Steel Connection		
	<p>Additional end terminal connection for stainless steel headers.</p>	<p><b>Model:</b>                  ALL APPLICATIONS                  NH<sub>3</sub></p>
120° Elbow Reducer		
		<p><b>Model:</b>                  ALL APPLICATIONS                  All Models</p>

Floor mounting support		
	<p>Feet in hot dip galvanized steel</p>	<p><b>Model:</b> <b>ALL APPLICATIONS</b> All Models</p>

## AirMaxII

## Electric Heater

## ALL SERIES

## Function

The elements are designed to operate in the refrigeration field with high moisture rate.

Special care is taken in selecting the type of power supply cables and insulation. Benefit less stream (defrost easy mounting)

## General data

Model	Electrical defrost - DX			
	Coil		Drip Tray	
	N° Heater	Total W	N° Heater	Total W
501A	6	4200	2	1400
501C	9	6300	2	1400
501E	12	8400	2	1400
502A	6	8400	2	2800
502C	9	12600	2	2800
502E	12	16800	2	2800
503A	6	12600	2	4200
503C	9	18900	2	4200
503E	12	25200	2	4200
504A	6	16200	2	5400
504C	9	24300	2	5400
504E	12	32400	2	5400
505A	6	20400	2	6800
505C	9	30600	2	6800
505E	12	40800	2	6800
561C	12	9600	2	1600
561E	15	12000	2	1600
561G	18	14400	2	1600
562C	12	19200	2	3200
562E	15	24000	2	3200
562G	18	28800	2	3200
563C	12	28800	2	4800
563E	15	36000	2	4800
563G	18	43200	2	4800
564C	12	38400	2	6400
564E	15	48000	2	6400
564G	18	57600	2	6400
565C	12	48000	2	8000
565E	15	60000	2	8000
565G	18	72000	2	8000
631C	12	9600	2	1600
631E	18	14400	2	1600
631G	21	16800	2	1600
632C	12	19200	2	3200
632E	18	28800	2	3200
632G	21	33600	2	3200
633C	12	28800	2	4800
633E	18	43200	2	4800
633G	21	50400	2	4800
634C	12	38400	2	6400
634E	18	57600	2	6400
634G	21	67200	2	6400
635C	12	48000	2	8000
635E	18	72000	2	8000
635G	21	84000	2	8000

Model	Electrical defrost - DX			
	Coil		Drip Tray	
	N° Heater	Total W	N° Heater	Total W
801C	18	18000	3	3000
801E	21	21000	3	3000
801G	21	21000	3	3000
802C	18	34200	3	5700
802E	21	39900	3	5700
802G	21	39900	3	5700
803C	18	52200	3	8700
803E	21	60900	3	8700
803G	21	60900	3	8700
804C	18	70200	3	11700
804E	21	81900	3	11700
804G	21	81900	3	11700



Model	Electrical defrost - W			
	Coil		Drip Tray	
	N° Heater	Total W	N° Heater	Total W
501A	6	4200	2	1400
501C	9	6300	2	1400
501D	12	8400	2	1400
501E	12	8400	2	1400
502A	6	8400	2	2800
502C	9	12600	2	2800
502D	12	16800	2	2800
502E	12	16800	2	2800
503A	6	12600	2	4200
503C	9	18900	2	4200
503D	12	25200	2	4200
503E	12	25200	2	4200
504A	6	16200	2	5400
504C	9	24300	2	5400
504D	12	32400	2	5400
504E	12	32400	2	5400
505A	6	20400	2	6800
505C	9	30600	2	6800
505D	12	40800	2	6800
505E	12	40800	2	6800
561C	12	9600	2	1600
561D	15	12000	2	1600
561E	15	12000	2	1600
561F	18	14400	2	1600
561G	18	14400	2	1600
562C	12	19200	2	3200
562D	15	24000	2	3200
562E	15	24000	2	3200
562F	18	28800	2	3200
562G	18	28800	2	3200
563C	12	28800	2	4800
563D	15	36000	2	4800
563E	15	36000	2	4800
563F	18	43200	2	4800
563G	18	43200	2	4800
564C	12	38400	2	6400
564D	15	48000	2	6400
564E	15	48000	2	6400
564F	18	57600	2	6400
564G	18	57600	2	6400
565C	12	48000	2	8000
565D	15	60000	2	8000
565E	15	60000	2	8000
565F	18	72000	2	8000
565G	18	72000	2	8000
631C	15	12000	2	1600
631D	18	14400	2	1600
631E	18	14400	2	1600
631F	21	16800	2	1600
631G	21	16800	2	1600
632C	15	24000	2	3200
632D	18	28800	2	3200
632E	18	28800	2	3200
632F	21	33600	2	3200
632G	21	33600	2	3200
633C	15	36000	2	4800
633D	18	43200	2	4800
633E	18	43200	2	4800
633F	21	50400	2	4800
633G	21	50400	2	4800
634C	15	48000	2	6400
634D	18	57600	2	6400
634E	18	57600	2	6400
634F	21	67200	2	6400
634G	21	67200	2	6400
635C	15	60000	2	8000
635D	18	72000	2	8000
635E	18	72000	2	8000
635F	21	84000	2	8000
635G	21	84000	2	8000

Model	Electrical defrost - W			
	Coil		Drip Tray	
	N° Heater	Total W	N° Heater	Total W
801C	18	18000	3	3000
801D	21	21000	3	3000
801E	21	21000	3	3000
801F	21	21000	3	3000
801G	21	21000	3	3000
802C	18	34200	3	5700
802D	21	39900	3	5700
802E	21	39900	3	5700
802F	21	39900	3	5700
802G	21	39900	3	5700
803C	18	52200	3	8700
803D	21	60900	3	8700
803E	21	60900	3	8700
803F	21	60900	3	8700
803G	21	60900	3	8700
804C	18	70200	3	11700
804D	21	81900	3	11700
804E	21	81900	3	11700
804F	21	81900	3	11700
804G	21	81900	3	11700

Model	Electrical defrost - NH3/HP(CO2)			
	Coil		Drip tray	
	N° Heater	Total W	N° Heater	Total W
501A	8	5600	2	1400
501B	9	6300	2	1400
501C	10	7000	2	1400
502A	8	11200	2	2800
502B	9	12600	2	2800
502C	10	14000	2	2800
503A	8	16800	2	4200
503B	9	18900	2	4200
503C	10	21000	2	4200
504A	8	21600	2	5400
504B	9	24300	2	5400
504C	10	27000	2	5400
505A	8	27200	2	6800
505B	9	30600	2	6800
505C	10	34000	2	6800
561B	10	8000	2	1600
561C	12	9600	2	1600
561D	15	12000	2	1600
562B	10	16000	2	3200
562C	12	19200	2	3200
562D	15	24000	2	3200
563B	10	24000	2	4800
563C	12	28800	2	4800
563D	15	36000	2	4800
564B	10	32000	2	6400
564C	12	38400	2	6400
564D	15	48000	2	6400
565B	10	40000	2	8000
565C	12	48000	2	8000
565D	15	60000	2	8000
631B	12	9600	2	1600
631C	15	12000	2	1600
631D	18	14400	2	1600
632B	12	19200	2	3200
632C	15	24000	2	3200
632D	18	28800	2	3200
633B	12	28800	2	4800
633C	15	36000	2	4800
633D	18	43200	2	4800
634B	12	38400	2	6400
634C	15	48000	2	6400
634D	18	57600	2	6400
635B	12	48000	2	8000
635C	15	60000	2	8000
635D	18	72000	2	8000

Model	Electrical defrost - NH3/HP(CO2)			
	Coil		Drip tray	
	N° Heater	Total W	N° Heater	Total W
801B	15	15000	3	3000
801C	18	18000	3	3000
801D	21	21000	3	3000
802B	15	28500	3	5700
802C	18	34200	3	5700
802D	21	39900	3	5700
803B	15	43500	3	8700
803C	18	52200	3	8700
803D	21	60900	3	8700
804B	15	58500	3	11700
804C	18	70200	3	11700
804D	21	81900	3	11700

# AirMaxII

## Code description

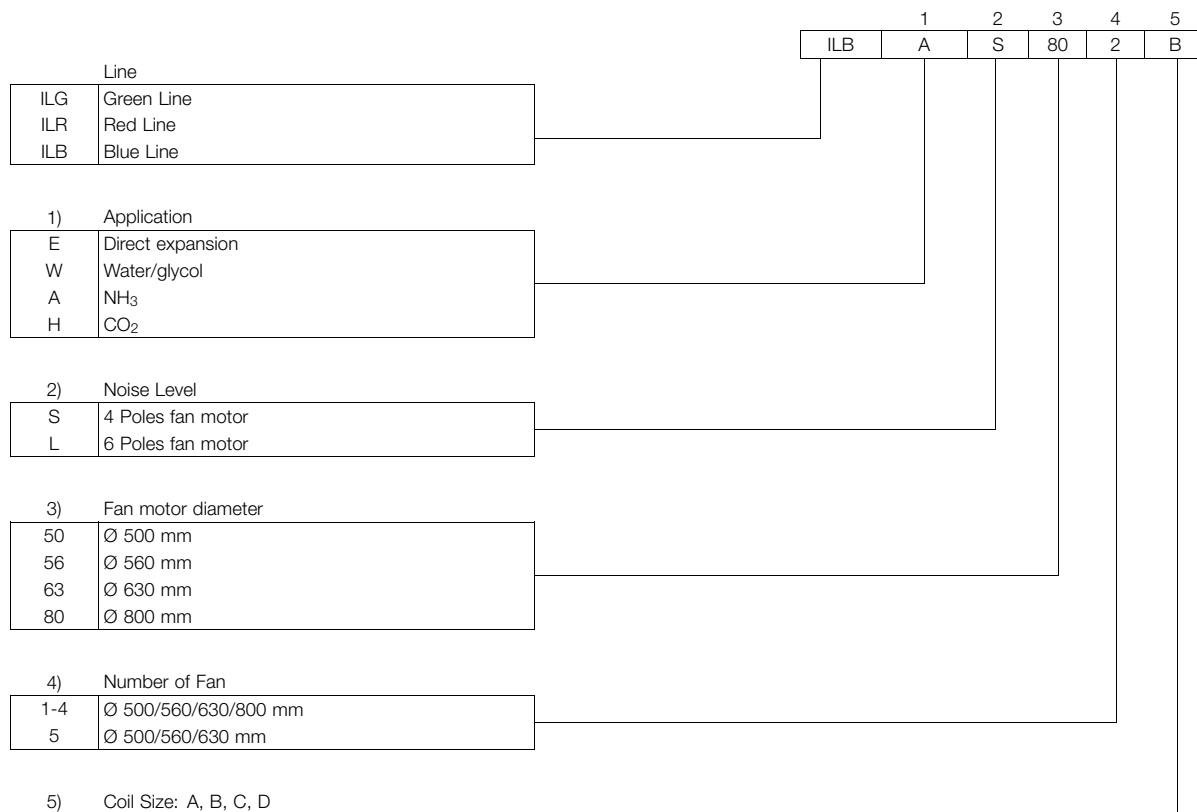

**General AlfaSelect Air Legend**

Description 1		Description 2	
<b>D</b>	D fan cabling (three phase)	<b>BSFT</b>	Basic Switch Board + Speed Control Temp. + Signal
<b>Y</b>	Y fan cabling (three phase)	<b>BI</b>	Basic Switch Board + Frequency Converter (Inverter)
<b>D/Y</b>	D/Y fan cabling (three phase), single speed fan motor	<b>BSI</b>	Basic Switch Board + Frequency Converter (Inverter) + Signal
<b>S</b>	Single phase	<b>C</b>	Switch Board + Cooling fan
<b>P</b>	Packing = pallet	<b>R</b>	Switch Board + Resistor
<b>CR</b>	Packing = crate	<b>F</b>	Switch Board + Cooling fan + Resistor
<b>BO</b>	Packing = box	<b>PT</b>	Ammonia pump top
<b>Feet</b>	Feet mounted	<b>PB</b>	Ammonia pump bottom
<b>SW</b>	Safety Switch	<b>AL</b>	Aluminium casing
<b>CB</b>	Terminal Box	<b>SS</b>	Stainless Steel casing
<b>B</b>	Basic Switch Board	<b>AP</b>	Prepainted Aluminium casing
<b>BS</b>	Basic Switch Board + Signal	<b>PL</b>	Plastic casing
<b>BP</b>	Basic Switch Board + Step Control Pressure	<b>E</b>	Electrical defrost
<b>BT</b>	Basic Switch Board + Step Control Temperature	<b>LE</b>	Low Electrical defrost
<b>BSP</b>	Basic Switch Board + Step Control Pressure + Signal	<b>A</b>	Air Defrost
<b>BST</b>	Basic Switch Board + Step Control Temp. + Signal	<b>HG</b>	Hot Gas Defrost
<b>BFP</b>	Basic Switch Board + Speed Control Pressure	<b>HG+E</b>	Hot Gas Defr. + Elect. Defr. on drip tray
<b>BFT</b>	Basic Switch Board + Speed Control Temperature	<b>W</b>	Water Defrost
<b>BSFP</b>	Basic Switch Board + Speed Control Pres. + Signal	<b>W+E</b>	Water Defrost + Elect. Defr. on drip tray
		<b>AL</b>	Aluminium fin
		<b>CU</b>	Copper fin
		<b>PR</b>	Precoated fin
		<b>SS</b>	Stainless steel tube
		<b>TH</b>	Thermoguard treatment
		<b>CF</b>	Cataphoresis treatment
		<b>SC</b>	Sub-cooling circuit
		<b>KW</b>	Spray water kit
		<b>FL</b>	Flanges
		<b>FH</b>	Fan ring heater
		<b>IS</b>	Insulated Drip Tray
		<b>RH</b>	Reheating coil
		<b>SR</b>	Air socket adapter ring
		<b>CW</b>	Air throw fan cowl
		<b>ER</b>	120° elbow reducer
		<b>HN</b>	Highed fan cowl

**Note: valid for all the product range**

# Ceiling / Dual Discharge

## General Contents

### General Features

This product is designed for use in cold rooms, air locks, laboratories, meat-cutting facilities, packing rooms and so on. The shape is generally low profile to save space in height; can be flush ceiling mounted, but may also be mounted on rods. Coolers like these work by drawing air in at the bottom (or at the top, if the product line is TFG) and then discharging it horizontally through the coils fitted on each side. The best performances are guaranteed if the cooler is placed in the centre of the room / dedicated area in which it is operating. These unit coolers are available in the following versions:

- Direct expansion evaporators
- Brine unit cooler
- Pump ammonia evaporator

### Certifications and reliability

All DX unit coolers are guaranteed by Eurovent "Certify All". Alfa Laval quality systems fully comply with ISO 9001, and all of our products are manufactured in strict accordance with CE regulations.

### Fin spacing

In our experience, fin spacing should correspond to both the goods stored and the room's air temperature, as follows:

Product	Fruit / Vegetables		Meat / Fish	Frozen food
	TFG	BFG		BFB
Room temperature	12 ÷ 0°C	10 ÷ 0°C		-18 ÷ -25°C
Fin spacing	4 mm	4 mm		7 mm
Series	TGL			TBL
Room temperature	10 ÷ 0°C			-18 ÷ -25°C
Fin spacing	4,5 mm			7 mm
Series			ITR	ITB
Room temperature			10 ÷ 0°C	-18 ÷ -25°C
Fin spacing			5 mm	7 mm

### Capacity

The standard conditions are in accordance with EN 328. The cooling capacities stated in the catalogue are the nominal capacities for Qn (wet conditions), in compliance with Eurovent regulations. In standard Qst conditions (dry), the nominal capacities are calculated with the following formula:

$$Q_n = Q_{st} \times \text{Wet Coil Factor}$$

Standard conditions	Air Inlet Temp °C	Evaporation Temp. (Dew point) °C	R.H.	Wet Coil Factor
SC1	10	0	85%	1,35
SC2	0	-8	85%	1,15
SC3	-18	-25	95%	1,05
SC4	-25	-31	95%	1,01

The nominal capacities are calculated with refrigerant R404A. For

different refrigerants the following factors should be applied:

Refrigerant	SC1	SC2	SC3	SC4
R134a	0,93	0,91	0,85	-
R22	0,95	0,05	0,95	0,95
R507	0,97	0,97	0,95	0,95
R404A	1	1	1	1

See the fin material factors below:

Fin material	Factor
Aluminium	1
Coated Aluminium	0,97
Copper	1,03

### Relative humidity ΔT

The cold room hygrometric conditions are defined by the room temperature and the working ΔT. At positive cold room temperatures ΔT has an influence on the relative humidity (RH).

### Air throw

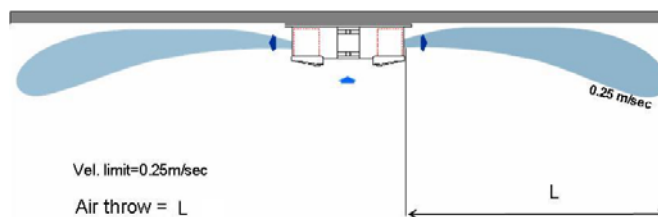

The values given in the tables are based on an air temperature of 20°C beneath a flat ceiling with no obstructions. The height and air circulation of the room can influence the air throw. The stated distances are based on a final air velocity of 0.25m/s. The value indicates the air flow from the unit to one side.

### Data Sound

Lp(A) is the A-weighted sound pressure level in a room with an absorption area of 100 m<sup>2</sup> (Sabine), with the observation point at a distance of 5 m and 45° horizontally below the middle point of the fans. Lw(A) is the A-weighted sound power level measured according to EN13487; annex C.

m	1	2	3	4	5
dB (A)	6	4	2	1	0

### Defrost

All our coolers come equipped with several different defrosting systems. For room temperatures where ice build-up is likely, and where the ambient room temperature is below 0°C, a unit with a defrosting system is needed



### Test and cleaning

The coils are cleaned and dehydrated in order to remove any traces of oil. Each heat exchanger undergoes a pressure and leak test with dry air at 30 bar, before being supplied with a nitrogen pre-charge.

### Guarantee

All our products are protected under warranty for 18 months from the shipping date. In the unlikely event of a defect occurring within the warranty period, please return the equipment or faulty part free of charge to us, where we will decide whether to repair or replace the goods. Unfortunately, We cannot take responsibility for damage caused by the misuse or incorrect installation of our products. Brochure subject to technical changes without prior notice

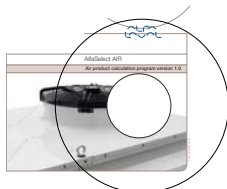

We recommend that you use the Alfa Select software for an exact thermal and mechanical design.

