

## ► Air Cooled Water Chillers

**VLS** (Cooling Only Version)

**VLH** (Heat Pump Version)

**VLR** (Total Heat Recovery Version)

**Models 524 to 1204**

 137 to 308 kW

 150 to 336 kW

 HFC 410A



Technical Catalogue

TM VL410-A.1GB

Date : April 2007

Supersedes : None

*Airwell*

# Key Points

- Units with **R410A refrigerant** (it will be the real replacement of R22). As near azeotropic mixture it behaves like a homogeneous substance (**reduced service problems in case of leakage or re-charge**) with negligible temperature glide.

Refrigerant with superior thermo-dynamical proprieties compared to R22 and R407C, it allows to have more efficiency or compact and lighter systems and larger operating limits (T ambient = -10 °C in heating mode).

- Units with EER (VLS - complete unit) values higher than 2.7 (**energy efficiency class C**).
- With except for the fans, all the versions keep the same configuration of the base units (same structure, electrical board, compressors and coils). **Easy upgrade of the units in stock or on the field.**
- **Bi-flow electronic expansion devices** on all units : superheating valve controlled by microprocessor, simple and accessible refrigeration system especially for heat pump versions with reduction of brazing points and then possible leakage.
- Optimized coils design (30% refrigerant charge reduction).
- **Compressors box (less sound proofing) always installed** - additional compressors jackets only for ELN version (**easy upgrade of the units in stock**).
- Special version (HSE) developed for high seasonal efficiency (ESEER higher than 4.5 (more than 15% compared to standard version)) and high operation limits with inverter fans (electronic brushless type motor). Axial fan of large diameter.

- Special version (SIF) for high external static pressure (max. 120 Pa) with inverter fans (electronic brushless type motor). Axial fan of large diameter. These fans are the same as those used on HSE units.
- Modified and improved base frame - AVM fitted underneath of base frame so no brackets request (no problem for track and container freight). In the same positions, the plastic feet will be installed for fork handling.
- **New microprocessor** : 4 times greater RAM memory compared with previous version, flash memory card and compressors envelope curves put inside, 3 times faster than previous control.
- **Hydro kits** with or without buffer tank (500 litres) fitted on board or on the back of the chiller to perform outstandingly the package solution and the plug & play concept.  
One or two water pumps are available : standard pressure (150 kPa) or high pressure (250 kPa). The water pump has a sound proof box for ELN version. The hydro kit with buffer tank can be easily connected at the base frame of the unit by a special "structure kit". **Easy upgrade of the units in stock or on the field.**
- For service operation, special valves dedicated to R410A are supplied on the refrigerant system. These valves, of 5/16" flare SAE type, are mounted on the liquid line and on the gauges manifold of the unit.

## Technical Features

### General

The new **VLS/VLH** units have been designed to operate with **HFC 410A** refrigerant. Both compressors and heat exchangers (plate heat exchanger and coils) have been optimized for this refrigerant.

They consist of **two independent refrigerant circuits**, a tandem high efficiency and low vibration level Scroll compressors on each circuit, a **"True Dual"** two-circuit plate heat exchanger and a ventilating unit comprising V-shape coils and quiet fans; each of them is located in an externally mounted nozzle profile housing generating low sound level.

The VLS units are available in **8 sizes**, from size 524 to 1204, with a nominal capacity range from **137 to 308 kW**.

The VLH units are available in **8 sizes**, from size 524 to 1204, with a nominal capacity range from **134 to 301 kW** in cooling mode and from **150 to 336 kW** in heating mode.

The VLS/VLH-STD (**Standard**) version can be supplied with **3 acoustic options** :

- **Base Low Noise (BLN)** : The units are equipped with **delta connected fans** implying a standard rpm. The chillers are not supplied with fan speed controller, but fitted with **compressors box** to reduce the noise emissions.
- **Low Noise (LN)** : The units are equipped with **star connected fans** implying a low rpm. The chillers are not supplied with fan speed controller, but fitted with **compressors box** to reduce the noise emissions.
- **Extra Low Noise (ELN)** : The units are equipped with **star connected fans**, fitted with a speed controller which allows the units to operate with a very low rpm. The chillers are supplied with **compressors box** and **soundproof jackets** on compressors reducing significantly the noise emissions.

To increase their field of applications, the VLS/VLH ranges are available in **3 additional versions** :

- **HSE (High Seasonal Efficiency) version** : It has same equipment as that of the STD version, except that the units are equipped with **special inverter fans**, of large diameter, driven by **EC (electronic brushless type) motors** with **integrated electronic inverter**, to ensure low energy consumption. This version can be supplied with BLN, LN or ELN acoustic options
- **HT (High Temperature) version** : It has same equipment as that of the BLN units, but the units are fitted with **special inverter fans and motors** identical to those of the HSE version, but with a different regulation. The HT version can be supplied with BLN acoustic option only.
- **SIF (Special Inverter Fan) version** : It has same equipment as that of the BLN units, except that the units are equipped with **special inverter fans** (same as those used on HSE version, but with a different regulation) driven by **EC motors** with **integrated electronic inverter**. The SIF version provides external static pressure up to **120 Pa**. This version can be supplied with BLN acoustic option only.

In addition, **2 heat recovery options** are available :

- **Desuperheater** : All the versions can be supplied with plate type heat exchangers fitted, one on each refrigerant circuit, on the compressor discharge line to recover about **20 % of the total heat** rejected to the condensers.
- **VLR units** : All the versions of the **cooling only** units can be supplied with a double circuit plate type heat exchanger to recover **100 % of heat rejection** by the condensers. 4-way valves and a field installed control sensor are also provided to ensure the cooling/heat recovery mode changeover.

### Reference standards

The following applies to all the sizes and versions of VLS/VLH/VLR units :

- ✓ Machine Directive EEC 98/37 (EN 292/1, EN 292/2)
- ✓ Low Voltage Directive EEC 73/23 (EN 60204-1, EN 60439-1)
- ✓ Electromagnetic Compatibility Directive EEC 89/336 as modified by Directive EEC 92/31 (EN 50081-1, EN 50082-2)
- ✓ Pressure Equipment Directive 97/23/CE

# Technical Features (continued)

---

## Cabinet and structure

---

The unit cabinet and structure are made of heavy gauge galvanized steel coated with polyester powder based painting (RAL 9001). All parts of the structure are fastened totally with non-corrosive screws and bolts.

## Compressors

---

Each unit is equipped with four compressors arranged in two tandems to suit the two refrigerant circuits.

The compressors are of hermetic scroll type and fitted with an electronic control system ensuring protection against high temperature and excessive load.

All compressors have direct-on-line starting and are mounted on rubber vibration isolators in order to minimize noise and vibration transmission.

## Evaporator

---

Evaporator is of a "Dual Circuit" brazed stainless steel plate type heat exchanger. It is insulated with a 19 mm thick closed cell polyethylene foam material and is fitted with a film type electric heater on the external surface to prevent the unit from freezing at a low temperature (down to -18 °C) when the unit is off.

Water connections are of a Victaulic type : 2"1/2 on sizes 524 to 804 and 3" on sizes 904 to 1204.

## Condenser coils

---

The condenser coils are made of seamless copper tubes, arranged in staggered rows, mechanically expanded into corrugated aluminum fins.

## Condenser fans

---

For each size, all versions keep the same number of fans.

Large diameter, direct drive axial type fans with asynchronous three-phase motors are used in all acoustic versions (BLN, LN & ELN) of VLS/VLH 524-1204 STD units.

Special inverter fans with electronic brushless type motors are used in VLS/VLH 524-1204 HSE, SIF and HT units.

On high pressure fans of SIF units, the external static pressure ( $\leq 120$  Pa) can be adjusted on site to match the customer demand directly from the electronic control panel of the unit.

Fans are equipped with externally mounted nozzle profile housing which generates low sound levels.

## Fan speed control

---

The speed of fans is controlled in order to operate at a low ambient temperature.

On units with standard axial fans, the fan speed control, supplied as standard, is of a temperature actuated step type (for BLN and LN versions) and of a pressure actuated stepless type with an electronic controller (for ELN version).

The pressure actuated stepless type fan speed controller can be supplied as optional on BLN and LN versions. It allows the units to operate in cooling mode at ambient temperature down to -18 °C.

On HSE and SIF units with electronic axial fans, the pressure actuated stepless type fan speed control is supplied as standard, because these electronic fans are already equipped with an integrated fan speed control (fan speed range : 50 to 1200 rpm; ambient temperature limit : -18 °C (in cooling mode only)).

## Refrigerant circuits

---

All the units are composed of two independent and separate refrigerant circuits.

Each refrigerant circuit is equipped with liquid line and discharge line shut-off valves, filter-drier with solid core, sight glass and **electronic expansion valve (EXV)**.

The heat pump units (VLH) are provided with 4-way reversing valves, suction accumulators and liquid receivers on the liquid lines.

The total heat recovery units (VLR) are supplied with 4-way reversing valves and liquid receivers downstream of the heat recovery condenser.

The functional diagram of each circuit is shown in the section "Refrigerant flow diagram".

## Electrical board

---

Metal case, externally arranged at one end of the unit. Case for the board with IP54 protection rating, complete with grille for natural air ventilation of the box.

## Control and safety devices

---

Each unit is fitted with the following devices :

### Safety :

- Power disconnect switch with an emergency stop function.
- HP switches (double on each circuit of sizes 1004 to 1204), set to 42 bar, automatic reset and manual reset from the control panel.
- Water differential pressure switch on the evaporator, set to 105 mbar (corresponding to about 50 % of the nominal capacity).
- Antifreeze temperature sensor (set to +4 °C) on the evaporator.
- Safety valve on discharge lines (for each evaporator), set to 46 bar.

### Control :

- HP and LP transducers (two for each circuit).
- Evaporator water inlet temperature sensor.
- Evaporator water outlet temperature sensor (with an antifreeze function).
- Suction temperature sensor for EXV control.
- Ambient air temperature sensor.
- Coil temperature sensors.
- Heat recovery condenser temperature sensor (VLR only).

## Electronic control

---

The units are supplied with the new microprocessor-based electronic control and management system ensuring the following functions :

- Management of the operation of compressors :
  - a) Power on/off
  - b) Anticycle management
  - c) Tandem unloading for high pressure or high compressor pressure ratio (integrated inside the curves of compressor operating limits).
- Chilled and hot water temperature regulation (control option on inlet water temperature RWT (P+I type) or outlet water temperature LWT (neutral band type) of the evaporator).
- Control of superheating on suction line.
- Evaporator antifreeze protection.
- Heat pump defrost control for automatic operation.

## Technical Features (continued)

---

- Management of high and low pressure alarms.
- Management of the electronic expansion valves by means of EXV controller allowing optimized functions : cooling, heating, start-up and defrost.
- Management of external interlocks.
- Management of the remote control :
  - d) Unit power on/off
  - e) Summary alarm signals
- Remote signalling, by dry contacts :
  - f) Voltage presence
  - g) Compressors in operation
  - h) Alarm, circuit 1
  - i) Alarm, circuit 2
- Management of the hydro kit : start-up of pump, antifreeze heater of external tank.
- Management of the heat recovery mode by means of inlet water temperature sensor at the heat recovery condenser.

The unit controller can also clearly show all control parameters of the machine on the liquid crystal display, such as :

- Display of superheating value.
- Display of the temperature at the evaporator inlet and outlet.
- Display of the ambient air temperature.
- Display of the circuit 1 and circuit 2 discharge pressure and suction pressure.
- Display of the set point.
- Display of the various alarm and operation status :
  - j) Compressor start-up alarm (discharge pressure check)
  - k) Low / High pressure
  - l) Low / High super-heating
  - m) Evaporator antifreeze
  - n) Flow switch signal for lack of water
  - o) Control of the compressor operating hours
  - p) Compressors in operation
  - q) Pump in operation and operating hours
  - r) Thermal protection of compressors
  - s) Thermal protection of fans
  - t) Faulty sensors

### Standard equipment

---

- ✓ Set point timer/clock card.
- ✓ Temperature actuated fan speed control.
- ✓ Back light display.
- ✓ Digital pressure and temperature reading kit.
- ✓ High ambient pressure control.
- ✓ Double set point (VLH only).
- ✓ Sequence phase control.
- ✓ Electronic expansion valves.
- ✓ Control circuit transformer 400 V/230 V.
- ✓ Data logger.
- ✓ Power supply without neutral.
- ✓ Hour meter.
- ✓ Main switch.
- ✓ Refrigerant R410A.
- ✓ PED approval.

- ✓ Evaporator antifreeze electric heater.
- ✓ Compressor jacket (ELN version only).
- ✓ Compressor box.
- ✓ Water pump acoustic box (ELN version only).
- ✓ Rubber anti-vibration pad.
- ✓ Water differential pressure switch.
- ✓ Antifreeze electric heater for hydraulic manifolds (brine application).

### Factory installed options

---

- ✓ ModBus protocol kit for BMS.
- ✓ Lonwork protocol kit for BMS.
- ✓ Bacnet protocol kit for BMS.
- ✓ Compressors soft starter.
- ✓ Pressure actuated stepless fan speed controller for low ambient operation (-18 °C).
- ✓ Double set point (VLS only).
- ✓ Power factor correction capacitors.
- ✓ Compressors overload protection.
- ✓ GSM.
- ✓ HP & LP manometers.
- ✓ Condenser coils with blue fins treatment.
- ✓ Condenser coils with "Fin Guard Silver" (polyurethane) treatment.
- ✓ Condenser coils with copper fins.
- ✓ Chiller grilles.
- ✓ Total heat recovery (VLR).
- ✓ Desuperheater.
- ✓ On board hydro kits (VLS/VLH only) without buffer tank, but with 1 or 2 low or high pressure pump(s) and relevant accessories. If hydro kit is supplied with one pump, the pump will be located inside the unit. If it is supplied with two pumps, the pumps will be located on the back of the unit.
- ✓ On board hydro kits (VLS/VLH only) with 500 litres buffer tank, 1 or 2 low or high pressure pump(s), antifreeze heater inside the tank and relevant accessories. Water pump(s) will be supplied with soundproof box on units in ELN version.
- ✓ On board hydro kits (VLS/VLH only) with 500 litres buffer tank and relevant accessories, but without pumps.

### Field-installed accessories

---

- ✓ Remote ON/OFF control.
- ✓ Airconet protocol kit for BMS.
- ✓ Remote keyboard panel.
- ✓ Master and slaves control, up to 4 units max.
- ✓ Spring anti-vibration mounts for basic unit.
- ✓ Spring anti-vibration mounts for unit with copper fins.
- ✓ Spring anti-vibration mounts for on board hydro kit with tank.
- ✓ Spring anti-vibration mounts for remote hydro kit.
- ✓ Flow switch.
- ✓ Water filter.
- ✓ Remote hydro kits with buffer tank, 1 or 2 low or high pressure pump(s), relevant accessories and with or without antifreeze heater :
  - 750 litres : sizes 524 to 904.
  - 1000 litres : sizes 1004 to 1204.

# Refrigerant Flow Diagram - VLS Units

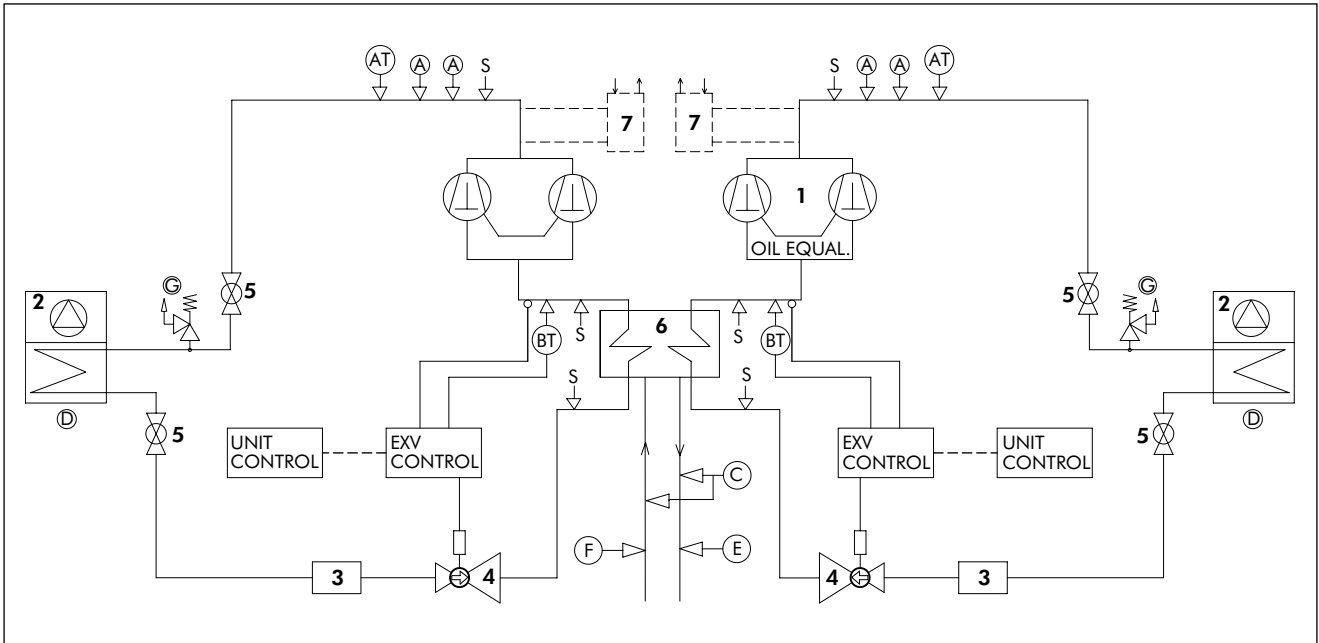

COMPONENTS	
1	Tandem Scroll type compressor
2	Air cooled condenser
3	Filter drier
4	Electronic expansion valve
5	Globe valve
6	Heat exchanger (Dual type)
7	Desuperheater (optional)

SAFETY / CONTROL DEVICES	
	High pressure switch
	High pressure transducer
	Low pressure transducer
	Water differential pressure switch
	Air temperature sensor
	Outlet water temperature sensor
	Inlet water temperature sensor
	PED pressure relief valve
	5/16" valve connection (service only)
	Pipe connection with Shrader valve

# Refrigerant Flow Diagram - VLH Units

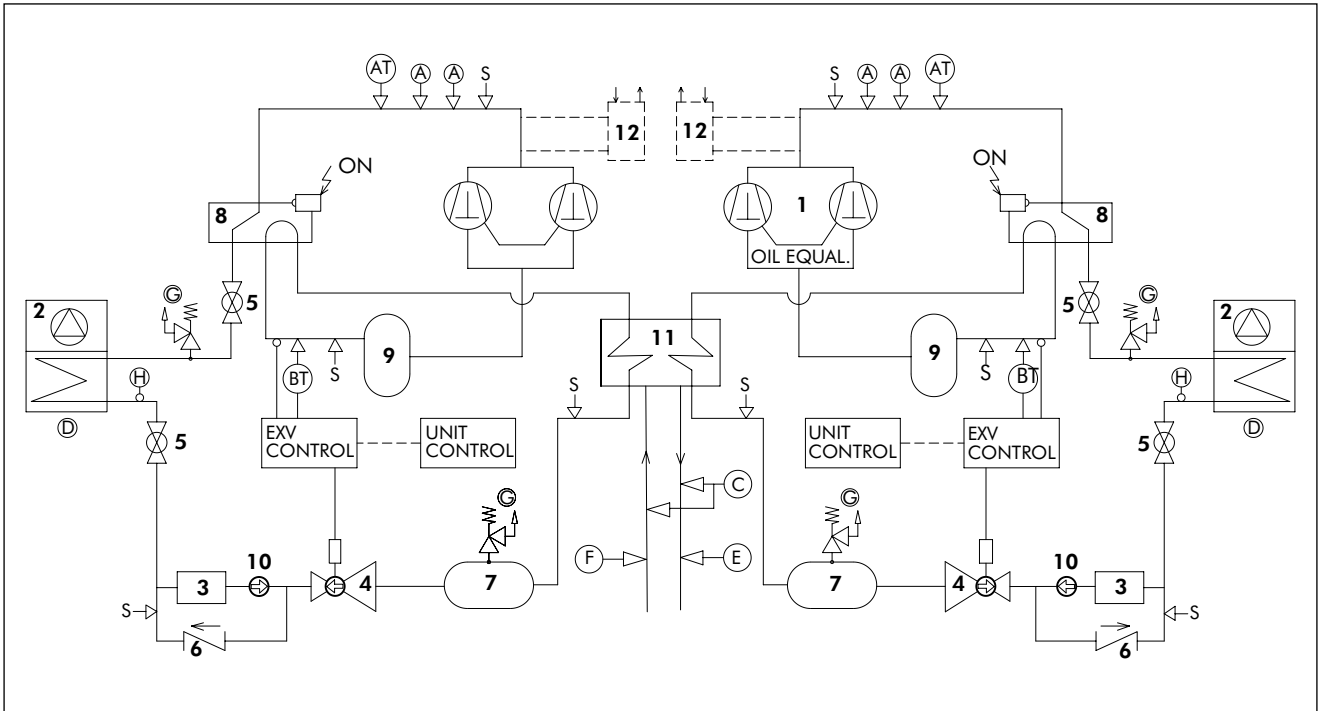

COMPONENTS	
1	Tandem Scroll type compressor
2	Air cooled condenser
3	Filter drier
4	Electronic expansion valve
5	Globe valve
6	Check valve
7	Liquid receiver
8	Four-way valve
9	Suction accumulator
10	Sight glass
11	Heat exchanger (Dual type)
12	Desuperheater (optional)

SAFETY / CONTROL DEVICES	
A	High pressure switch
AT	High pressure transducer
BT	Low pressure transducer
C	Water differential pressure switch
D	Air temperature sensor
E	Outlet water temperature sensor
F	Inlet water temperature sensor
G	PED pressure relief valve
H	Defrost temperature sensor
S	5/16" valve connection (service only)
↓	Pipe connection with Shrader valve

# Refrigerant Flow Diagram - VLR Units

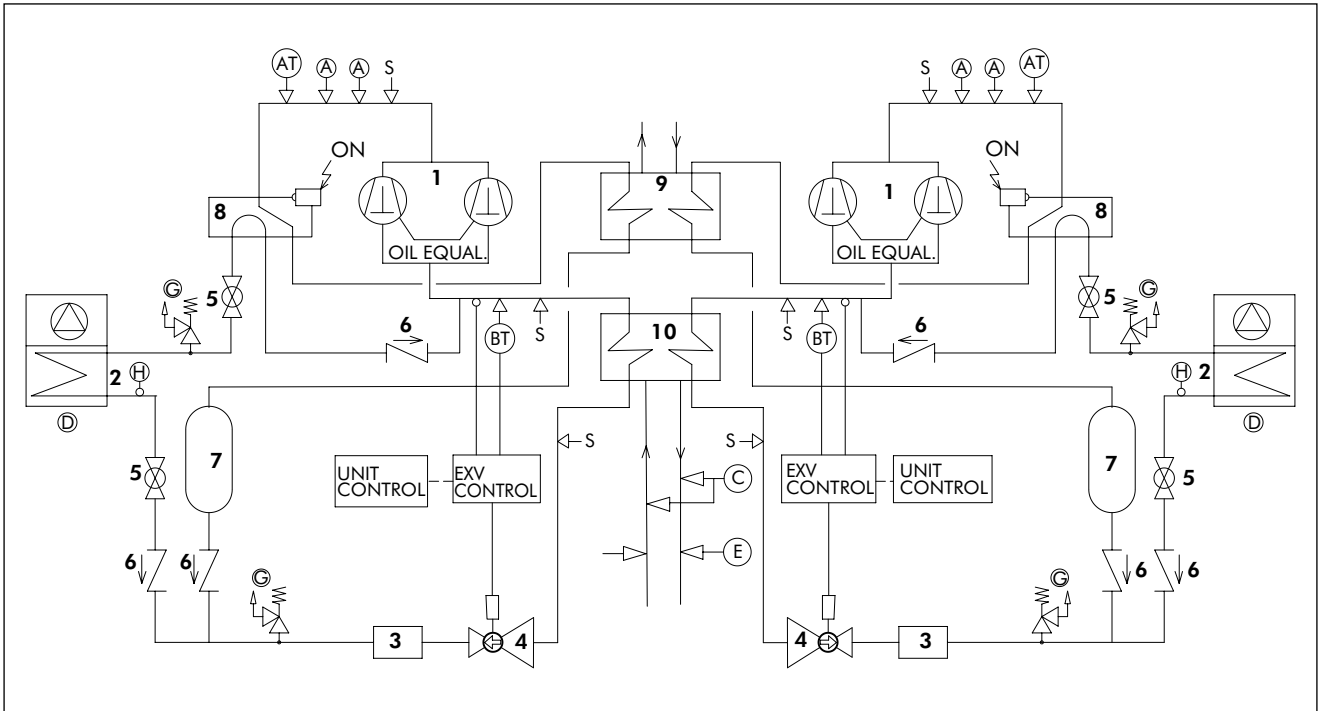

COMPONENTS	
1	Tandem Scroll type compressor
2	Air cooled condenser
3	Filter drier
4	Electronic expansion valve
5	Globe valve
6	Check valve
7	Liquid receiver
8	Four-way valve
9	Heat recovery (Dual type)
10	Heat exchanger (Dual type)

SAFETY / CONTROL DEVICES	
	High pressure switch
	High pressure transducer
	Low pressure transducer
	Water differential pressure switch
	Air temperature sensor
	Outlet water temperature sensor
	Inlet water temperature sensor
	PED pressure relief valve
	Defrost temperature sensor
	5/16" valve connection (service only)
	Pipe connection with Shrader valve

# Operating Limits and Correction Factors - VLS Units

## Operating limits - VLS 524 to 804

VLS			524		604		704		804	
			Min.	Max.	Min.	Max.	Min.	Max.	Min.	Max.
Chiller	Liquid outlet temperature	Water outlet °C	+6 to +15							
		Brine outlet °C	-8 to +15							
		ΔT K	3 to 8							
	Flow rate (1)	l/h	14685	39159	16587	44233	19017	50711	22360	59627
	Pressure drop (1)	kPa	11.1	78.6	14.1	100.3	18.5	131.8	21.0	149.4
	Max. operating pressure - Water side	bar	10							
Ambient air	Air entering temperature	Cooling - BLN °C	+0 to +46 (3)		-5 to +47 (3)		-5 to +47 (3)		+0 to +46 (3)	
		Cooling - LN/ELN °C	+0 to +44 (3)		-5 to +45 (3)		-5 to +45 (3)		+0 to +44 (3)	
		Cooling - HT °C	-18 to +48 (3)		-18 to +49 (3)		-18 to +49 (3)		-18 to +48 (3)	
	External static pressure	Standard fans Pa	0							
		Special inverter fans Pa	≤120							
Recommended system chilled water volume (2)	litres	380		450		550		620		
Minimum capacity step	%	25		28		20		25		
Power supply voltage (4)		400 V / 3 Ph / 50 Hz (nominal)								

- (1) Total unit flow rate and pressure are given for BLN units.  
Caution : Minimum flow rates may only be used with brine solutions after reprogramming the unit parameters.
- (2) Minimum water/brine volume of system (about 3 litres/kW).
- (3) High pressure switch at 42 bar.
- (4) Voltage : 400 V ± 10 %

## Operating limits - VLS 904 to 1204

VLS			904		1004		1104		1204	
			Min.	Max.	Min.	Max.	Min.	Max.	Min.	Max.
Chiller	Liquid outlet temperature	Water outlet °C	+6 to +15							
		Brine outlet °C	-8 to +15							
		ΔT K	3 to 8							
	Flow rate (1)	l/h	24607	65618	27219	72584	30057	80152	33078	88207
	Pressure drop (1)	kPa	9.0	64.0	11.0	78.4	13.4	95.5	16.3	115.7
	Max. operating pressure - Water side	bar	10							
Ambient air	Air entering temperature	Cooling - BLN °C	+0 to +47 (3)		+0 to +46 (3)		+0 to +45 (3)		+0 to +45 (3)	
		Cooling - LN/ELN °C	+0 to +45 (3)		+0 to +44 (3)		+0 to +42 (3)		+0 to +42 (3)	
		Cooling - HT °C	-18 to +49 (3)		-18 to +48 (3)		-18 to +47 (3)		-18 to +47 (3)	
	External static pressure	Standard fans Pa	0							
		Special inverter fans Pa	≤120							
Recommended system chilled water volume (2)	litres	700		790		870		940		
Minimum capacity step	%	28		25		23		25		
Power supply voltage (4)		400 V / 3 Ph / 50 Hz (nominal)								

- (1) Total unit flow rate and pressure are given for BLN units.  
Caution : Minimum flow rates may only be used with brine solutions after reprogramming the unit parameters.
- (2) Minimum water/brine volume of system (about 3 litres/kW).
- (3) High pressure switch at 42 bar.
- (4) Voltage : 400 V ± 10 %



# Operating Limits and Correction Factors - VLH Units

## Operating limits - VLH 524 to 804

VLH				524		604		704		804	
				Min.	Max.	Min.	Max.	Min.	Max.	Min.	Max.
Chiller	Liquid outlet temperature	Water outlet	°C	+6 to +15							
		Brine outlet	°C	-8 to +15							
		ΔT	K	3 to 8							
	Flow rate (1)	l/h	14685	39159	16587	44233	19017	50711	22360	59627	
	Pressure drop (1)	kPa	11.1	78.6	14.1	100.3	18.5	131.8	21.0	149.4	
Max. operating pressure - Water side		bar	10								
Heat pump		Water outlet	°C	+30 to +50							
Ambient air	Air entering temperature	Cooling - BLN	°C	+0 to +46	-5 to +47	-5 to +47	+0 to +46				
		Cooling - LN/ELN	°C	+0 to +44	-5 to +45	-5 to +45	+0 to +44				
		Cooling - HT	°C	-18 to +48	-18 to +49	-18 to +49	-18 to +48				
		Heating (3)	°C	-10 to +20							
	External static pressure	Standard fans	Pa	0							
		Special inverter fans	Pa	≤120							
Recommended system chilled water volume (2)		litres	380	450	550	620					
Minimum capacity step		%	25	28	20	25					
Power supply voltage (4)			400 V / 3 Ph / 50 Hz (nominal)								

(1) Total unit flow rate and pressure are given for BLN units.

Caution : Minimum flow rates may only be used with brine solutions after reprogramming the unit parameters.

(2) Minimum water/brine volume of system (about 3 litres/kW).

(3) Max. leaving water temperature = 40 °C at -10 °C in fully loaded conditions and leaving water temperature = 45 °C in part loaded conditions.

(4) Voltage : 400 V ± 10 %

## Operating limits - VLH 904 to 1204

VLH				904		1004		1104		1204	
				Min.	Max.	Min.	Max.	Min.	Max.	Min.	Max.
Chiller	Liquid outlet temperature	Water outlet	°C	+6 to +15							
		Brine outlet	°C	-8 to +15							
		ΔT	K	3 to 8							
	Flow rate (1)	l/h	24607	65618	27219	72584	30057	80152	33078	88207	
	Pressure drop (1)	kPa	9.0	64.0	11.0	78.4	13.4	95.5	16.3	115.7	
Max. operating pressure - Water side		bar	10								
Heat pump		Water outlet	°C	+30 to +50							
Ambient air	Air entering temperature	Cooling - BLN	°C	+0 to +47	+0 to +46	+0 to +45	+0 to +45				
		Cooling - LN/ELN	°C	+0 to +45	+0 to +44	+0 to +42	+0 to +42				
		Cooling - HT	°C	-18 to +49	-18 to +48	-18 to +47	-18 to +47				
		Heating (3)	°C	-10 to +20							
	External static pressure	Standard fans	Pa	0							
		Special inverter fans	Pa	≤120							
Recommended system chilled water volume (2)		litres	700	790	870	940					
Minimum capacity step		%	28	25	23	25					
Power supply voltage (4)			400 V / 3 Ph / 50 Hz (nominal)								

(1) Total unit flow rate and pressure are given for BLN units.

Caution : Minimum flow rates may only be used with brine solutions after reprogramming the unit parameters.

(2) Minimum water/brine volume of system (about 3 litres/kW).

(3) Max. leaving water temperature = 40 °C at -10 °C in fully loaded conditions and leaving water temperature = 45 °C in part loaded conditions.

(4) Voltage : 400 V ± 10 %

## Operating Limits and Correction Factors (continued)

### Fouling factors

EVAPORATOR			CONDENSER		
Fouling factor (m <sup>2</sup> .°C/kW)	Cooling capacity factor	Power input factor	Fouling factor (m <sup>2</sup> .°C/kW)	Cooling capacity factor	Power input factor
0.044	1.000	1.000	0.044	1.000	1.000
0.088	0.987	0.995	0.088	0.987	1.023
0.176	0.964	0.985	0.176	0.955	1.068
0.352	0.915	0.962	0.352	0.910	1.135

### Altitude factors

Altitude (m)	Cooling capacity factor	Power input factor
0	1.000	1.000
600	0.987	1.010
1200	0.973	1.020
1800	0.958	1.029
2400	0.943	1.038

## System Water Volume

The minimum system water volume is calculated using **the minimum compressor running time (1.5 minute for scroll compressor)** and the **lower capacity step** (only one compressor running among the four compressors installed) :

$$V = \frac{P \times t}{(n \times 25 \times \Delta T)}$$

Where **V** : Water volume (litre)  
**P** : Unit total cooling capacity (W)  
**n** : Number of compressor steps  
**t** : Compressor minimum running time (minute)  
**ΔT** : Evaporator temperature difference (°C)

With t = 1.5 minute, ΔT = 5 °C and n = 4, the minimum system water volume is about **V = 3 litres/kW**.

# Physical Data - VLS STD/HSE/SIF-BLN Version

VLS STD/HSE/SIF-BLN models		524	604	704	804	904	1004	1104	1204
Nominal cooling capacity (1)	kW	136.6	154.3	176.9	198.8	228.9	250.9	279.6	307.7
Input power (2)	kW	45.0	49.7	59.4	65.5	74.6	78.5	91.6	106.2
EER (2)		3.04	3.10	2.98	3.04	3.07	3.20	3.05	2.90
EER (Total unit)		2.80	2.79	2.72	2.79	2.78	2.91	2.82	2.70
ESEER		3.79	3.77	3.68	3.78	3.77	3.94	3.81	3.66
EER (Total unit) (*)		2.87	2.87	2.79	2.86	2.86	2.99	2.89	2.76
ESEER (*)		4.36	4.37	4.24	4.35	4.36	4.55	4.39	4.20
Number of refrigerant circuits		2	2	2	2	2	2	2	2
Total capacity steps	%	25-50-75-100	28-57-78-100	20-50-70-100	25-50-75-100	28-50-78-100	25-50-75-100	23-50-73-100	25-50-75-100
<b>COMPRESSORS</b>									
Number		4	4	4	4	4	4	4	4
Type		SCROLL							
Oil type		POE							
N° of loading stages		0/100	0/100	0/100	0/100	0/100	0/100	0/100	0/100
<b>EVAPORATOR</b>									
Number		1	1	1	1	1	1	1	1
Type		PLATE	PLATE	PLATE	PLATE	PLATE	PLATE	PLATE	PLATE
Water volume	litres	11.5	11.5	11.5	13.3	25.2	25.2	25.2	25.2
<b>AIR COOLED CONDENSERS</b>									
Number of coils		2	2	2	2	2	2	2	2
Total coil face area per coil	m <sup>2</sup>	3.5	3.5	4.8	4.8	4.8	4.8	4.8	4.8
<b>FANS</b>									
Number of fans		2	3	3	3	4	4	4	4
Nominal speed	rpm	900	900	900	900	900	900	900	900
Total airflow	m <sup>3</sup> /h	46300	63000	68300	68300	85000	80000	75500	75500
Total input power	kW	3.8	5.7	5.7	5.7	7.6	7.6	7.6	7.6
Total input power (*)	kW	2.6	4.0	4.0	4.0	5.3	5.3	5.3	5.3
External static pressure	Pa	0 or 120 Pa (**)							
<b>WEIGHT</b>									
Shipping weight	kg	1188	1413	1603	1746	1880	2010	2100	2110
Operating weight	kg	1200	1425	1615	1760	1905	2035	2125	2135
<b>ADDITIONAL WEIGHT</b>									
HSE/SIF versions	kg	30	30	30	30	40	40	40	40
Desuperheater versions	kg	20	20	20	30	30	30	30	30
With one pump	kg	50	50	85	85	90	90	95	95
With two pumps	kg	140	140	200	200	205	205	215	215
Copper fins	kg	380	380	520	520	520	700	880	880
<b>SOUND LEVELS</b>									
Sound power level (3)	dB(A)	92	93	93	93	94	94	95	95
Sound pressure level - (10 m) (4)	dB(A)	60	61	61	61	62	62	63	63
<b>DIMENSIONS</b>									
Length	mm	3300	3300	4300	4300	4300	4300	4300	4300
Width	mm	1100	1100	1100	1100	1100	1100	1100	1100
Height	mm	2300	2300	2300	2300	2300	2300	2300	2300

(1) Data based on 7 °C leaving chilled water temperature and 35 °C ambient air temperature.

(2) Compressors only.

(3) Sound levels are at fully loaded conditions. Sound power level values refer to ISO standard 3744 and Eurovent 8/1.

(4) Sound pressure levels refer to ISO standard 3744, parallelepiped shape.

(\*) High efficiency units (HSE) with inverter fans.

(\*\*) SIF units with high static pressure fans.

# Physical Data - VLS STD/HSE-LN Version

VLS STD/HSE-LN models		524	604	704	804	904	1004	1104	1204
Nominal cooling capacity (1)	kW	132.2	149.8	172.2	193.1	222.8	241.6	267.2	292.8
Input power (2)	kW	47.3	52.1	62.2	68.9	78.4	83.1	98.2	114.5
EER (2)		2.79	2.88	2.77	2.80	2.84	2.91	2.72	2.56
EER (Total unit)		2.66	2.69	2.62	2.66	2.68	2.75	2.59	2.45
ESEER		3.90	3.94	3.84	3.90	3.93	4.03	3.80	3.60
EER (Total unit) (*)		2.72	2.78	2.69	2.73	2.75	2.82	2.65	2.50
ESEER (*)		4.30	4.38	4.24	4.31	4.35	4.45	4.19	3.95
Number of refrigerant circuits		2	2	2	2	2	2	2	2
Total capacity steps	%	25-50-75-100	28-57-78-100	20-50-70-100	25-50-75-100	28-50-78-100	25-50-75-100	23-50-73-100	25-50-75-100
<b>COMPRESSORS</b>									
Number		4	4	4	4	4	4	4	4
Type		SCROLL							
Oil type		POE							
N° of loading stages		0/100	0/100	0/100	0/100	0/100	0/100	0/100	0/100
<b>EVAPORATOR</b>									
Number		1	1	1	1	1	1	1	1
Type		PLATE	PLATE	PLATE	PLATE	PLATE	PLATE	PLATE	PLATE
Water volume	litres	11.5	11.5	11.5	13.3	25.2	25.2	25.2	25.2
<b>AIR COOLED CONDENSERS</b>									
Number of coils		2	2	2	2	2	2	2	2
Total coil face area per coil	m <sup>2</sup>	3.5	3.5	4.8	4.8	4.8	4.8	4.8	4.8
<b>FANS</b>									
Number of fans		2	3	3	3	4	4	4	4
Nominal speed	rpm	700	700	700	700	700	700	700	700
Total airflow	m <sup>3</sup> /h	35400	47300	52200	52200	63700	58800	54900	54900
Total input power	kW	2.4	3.6	3.6	3.6	4.8	4.8	4.8	4.8
Total input power (*)	kW	1.2	1.9	1.9	1.9	2.5	2.5	2.5	2.5
External static pressure	Pa	0							
<b>WEIGHT</b>									
Shipping weight	kg	1188	1413	1603	1746	1880	2010	2100	2110
Operating weight	kg	1200	1425	1615	1760	1905	2035	2125	2135
<b>ADDITIONAL WEIGHT</b>									
HSE versions	kg	30	30	30	30	40	40	40	40
Desuperheater versions	kg	20	20	20	30	30	30	30	30
With one pump	kg	50	50	85	85	90	90	95	95
With two pumps	kg	140	140	200	200	205	205	215	215
Copper fins	kg	380	380	520	520	520	700	880	880
<b>SOUND LEVELS</b>									
Sound power level (3)	dB(A)	86	87	87	87	88	88	89	89
Sound pressure level - (10m) (4)	dB(A)	54	55	55	55	56	56	57	57
<b>DIMENSIONS</b>									
Length	mm	3300	3300	4300	4300	4300	4300	4300	4300
Width	mm	1100	1100	1100	1100	1100	1100	1100	1100
Height	mm	2300	2300	2300	2300	2300	2300	2300	2300

(1) Data based on 7 °C leaving chilled water temperature and 35 °C ambient air temperature.

(2) Compressors only.

(3) Sound levels are at fully loaded conditions. Sound power level values refer to ISO standard 3744 and Eurovent 8/1.

(4) Sound pressure levels refer to ISO standard 3744, parallelepiped shape.

(\*) High efficiency units (HSE) with inverter fans.

# Physical Data - VLS STD/HSE-ELN Version

VLS STD/HSE-ELN models		524	604	704	804	904	1004	1104	1204
Nominal cooling capacity (1)	kW	127.7	146.0	167.2	186.8	216.7	234.7	258.8	282.9
Input power (2)	kW	49.7	54.2	65.1	72.4	81.8	86.6	102.6	120.0
EER (2)		2.57	2.69	2.57	2.58	2.65	2.71	2.52	2.36
EER (Total unit)		2.47	2.55	2.46	2.48	2.53	2.59	2.43	2.28
ESEER		3.85	3.98	3.83	3.86	3.94	4.04	3.78	3.56
EER (Total unit) (*)		2.54	2.65	2.53	2.55	2.61	2.67	2.49	2.33
ESEER (*)		4.21	4.39	4.20	4.23	4.33	4.43	4.14	3.87
Number of refrigerant circuits		2	2	2	2	2	2	2	2
Total capacity steps	%	25-50-75-100	28-57-78-100	20-50-70-100	25-50-75-100	28-50-78-100	25-50-75-100	23-50-73-100	25-50-75-100
<b>COMPRESSORS</b>									
Number		4	4	4	4	4	4	4	4
Type		SCROLL							
Oil type		POE							
N° of loading stages		0/100	0/100	0/100	0/100	0/100	0/100	0/100	0/100
<b>EVAPORATOR</b>									
Number		1	1	1	1	1	1	1	1
Type		PLATE	PLATE	PLATE	PLATE	PLATE	PLATE	PLATE	PLATE
Water volume	litres	11.5	11.5	11.5	13.3	25.2	25.2	25.2	25.2
<b>AIR COOLED CONDENSER</b>									
Number of coils		2	2	2	2	2	2	2	2
Total coil face area per coil	m <sup>2</sup>	3.5	3.5	4.8	4.8	4.8	4.8	4.8	4.8
<b>FANS</b>									
Number of fans		2	3	3	3	4	4	4	4
Nominal speed	rpm	550	550	550	550	550	550	550	550
Total airflow	m <sup>3</sup> /h	28300	38500	41800	41800	52000	48900	46200	46200
Total input power	kW	2	3	3	3	4	4	4	4
Total input power (*)	kW	0.6	0.9	0.9	0.9	1.2	1.2	1.2	1.2
External static pressure	Pa	0							
<b>WEIGHT</b>									
Shipping weight	kg	1218	1448	1638	1781	1915	2050	2140	2150
Operating weight	kg	1230	1460	1650	1795	1940	2075	2165	2175
<b>ADDITIONAL WEIGHT</b>									
HSE versions	kg	30	30	30	30	40	40	40	40
Desuperheater versions	kg	20	20	20	30	30	30	30	30
With one pump	kg	50	50	85	85	90	90	95	95
With two pumps	kg	140	140	200	200	205	205	215	215
Copper fins	kg	380	380	520	520	520	700	880	880
<b>SOUND LEVELS</b>									
Sound power level (3)	dB(A)	83	83	83	83	84	84	85	85
Sound pressure level - (10m) (4)	dB(A)	51	51	51	51	52	52	53	53
<b>DIMENSIONS</b>									
Length	mm	3300	3300	4300	4300	4300	4300	4300	4300
Width	mm	1100	1100	1100	1100	1100	1100	1100	1100
Height	mm	2300	2300	2300	2300	2300	2300	2300	2300

(1) Data based on 7 °C leaving chilled water temperature and 35 °C ambient air temperature.

(2) Compressors only.

(3) Sound levels are at fully loaded conditions. Sound power level values refer to ISO standard 3744 and Eurovent 8/1.

(4) Sound pressure levels refer to ISO standard 3744, parallelepiped shape.

(\*) High efficiency units (HSE) with inverter fans.

# Physical Data - VLS HT

VLS HT models		524	604	704	804	904	1004	1104	1204
Nominal cooling capacity (1)	kW	138.1	156.1	178.6	200.9	231.7	254.2	282.4	313.3
Input power (2)	kW	44.2	48.7	58.4	64.4	73.2	76.8	89.9	103.1
EER (2)		3.12	3.21	3.06	3.12	3.17	3.31	3.14	3.04
EER (Total unit)		2.84	2.79	2.74	2.82	2.80	2.93	2.83	2.77
Number of refrigerant circuits		2	2	2	2	2	2	2	2
Total capacity steps	%	25-50-75-100	28-57-78-100	20-50-70-100	25-50-75-100	28-50-78-100	25-50-75-100	23-50-73-100	25-50-75-100
<b>COMPRESSORS</b>									
Number		4	4	4	4	4	4	4	4
Type		SCROLL							
Oil type		POE							
N° of loading stages		0/100	0/100	0/100	0/100	0/100	0/100	0/100	0/100
<b>EVAPORATOR</b>									
Number		1	1	1	1	1	1	1	1
Type		PLATE	PLATE	PLATE	PLATE	PLATE	PLATE	PLATE	PLATE
Water volume	litres	11.5	11.5	11.5	13.3	25.2	25.2	25.2	25.2
<b>AIR COOLED CONDENSERS</b>									
Number of coils		2	2	2	2	2	2	2	2
Total coil face area per coil	m <sup>2</sup>	3.5	3.5	4.8	4.8	4.8	4.8	4.8	4.8
<b>FANS</b>									
Number of fans		2	3	3	3	4	4	4	4
Nominal speed	rpm	1110	1110	1110	1110	1110	1110	1110	1110
Total airflow	m <sup>3</sup> /h	51700	71800	76200	76200	95800	91200	87600	87600
Total input power (*)	kW	4.5	7.2	6.9	6.9	9.6	9.9	10	10
External static pressure	Pa	0							
<b>WEIGHT</b>									
Shipping weight	kg	1218	1443	1633	1776	1920	2050	2140	2150
Operating weight	kg	1230	1455	1645	1790	1945	2075	2165	2175
<b>ADDITIONAL WEIGHT</b>									
Desuperheater versions	kg	20	20	20	30	30	30	30	30
With one pump	kg	50	50	85	85	90	90	95	95
With two pumps	kg	140	140	200	200	205	205	215	215
Copper fins	kg	380	380	520	520	520	700	880	880
<b>SOUND LEVELS</b>									
Sound power level (3)	dB(A)	97	99	99	99	100	100	100	100
Sound pressure level - (10m) (4)	dB(A)	65	67	67	67	68	68	68	68
<b>DIMENSIONS</b>									
Length	mm	3300	3300	4300	4300	4300	4300	4300	4300
Width	mm	1100	1100	1100	1100	1100	1100	1100	1100
Height	mm	2300	2300	2300	2300	2300	2300	2300	2300

(1) Data based on 7 °C leaving chilled water temperature and 35 °C ambient air temperature.

(2) Compressors only.

(3) Sound levels are at fully loaded conditions. Sound power level values refer to ISO standard 3744 and Eurovent 8/1.

(4) Sound pressure levels refer to ISO standard 3744, parallelepiped shape.

(\*) High temperature units (HT) with inverter fans.

# Physical Data - VLH STD/HSE/SIF-BLN Version

VLH STD/HSE/SIF-BLN models		524	604	704	804	904	1004	1104	1204
Nominal cooling capacity (1)	kW	134.2	150.1	174.0	197.6	226.7	246.8	273.9	300.5
Input power (3)	kW	45.0	50.2	59.4	65.5	74.2	78.4	91.3	105.7
EER (3)		2.98	2.99	2.93	3.02	3.06	3.15	3.00	2.84
EER (Total unit)		2.75	2.69	2.67	2.78	2.77	2.87	2.77	2.65
ESEER		3.72	3.63	3.62	3.75	3.75	3.88	3.75	3.59
EER (Total unit) (*)		2.82	2.77	2.74	2.84	2.85	2.95	2.84	2.71
ESEER (*)		4.29	4.21	4.17	4.32	4.34	4.48	4.31	4.12
Nominal heating capacity (2)	kW	149.6	169.0	199.2	234.9	254.1	272.5	300.8	335.8
Input power (3)	kW	44.7	51.3	60.6	69.8	71.4	79.3	91.3	103.4
COP (3)		3.35	3.29	3.29	3.37	3.56	3.44	3.29	3.25
Number of refrigerant circuits		2	2	2	2	2	2	2	2
Total capacity steps	%	25-50-75-100	28-57-78-100	20-50-70-100	25-50-75-100	28-50-78-100	25-50-75-100	23-50-73-100	25-50-75-100
<b>COMPRESSORS</b>									
Number		4	4	4	4	4	4	4	4
Type		SCROLL							
Oil type		POE							
N° of loading stages		0/100	0/100	0/100	0/100	0/100	0/100	0/100	0/100
<b>EVAPORATOR</b>									
Number		1	1	1	1	1	1	1	1
Type		PLATE	PLATE	PLATE	PLATE	PLATE	PLATE	PLATE	PLATE
Water volume	litres	11.5	11.5	11.5	13.3	25.2	25.2	25.2	25.2
<b>AIR COOLED CONDENSERS</b>									
Number of coils		2	2	2	2	2	2	2	2
Total coil face area per coil	m <sup>2</sup>	3.5	3.5	4.8	4.8	4.8	4.8	4.8	4.8
<b>FANS</b>									
Number of fans		2	3	3	3	4	4	4	4
Nominal speed	rpm	900	900	900	900	900	900	900	900
Total airflow	m <sup>3</sup> /h	46300	63000	68300	68300	85000	80000	75500	75500
Total input power	kW	3.8	5.7	5.7	5.7	7.6	7.6	7.6	7.6
Total input power (*)	kW	2.6	4.0	4.0	4.0	5.3	5.3	5.3	5.3
External static pressure	Pa	0 or 120 Pa (**)							
<b>WEIGHT</b>									
Shipping weight	kg	1248	1473	1663	1806	1955	2100	2190	2200
Operating weight	kg	1260	1485	1675	1820	1980	2125	2215	2225
<b>ADDITIONAL WEIGHT</b>									
HSE/SIF versions	kg	30	30	30	30	40	40	40	40
Desuperheater versions	kg	20	20	20	30	30	30	30	30
With one pump	kg	50	50	85	85	90	90	95	95
With two pumps	kg	140	140	200	200	205	205	215	215
Copper fins	kg	380	380	520	520	520	700	880	880
<b>SOUND LEVELS</b>									
Sound power level (4)	dB(A)	92	93	93	93	94	94	95	95
Sound pressure level - (10m) (5)	dB(A)	60	61	61	61	62	62	63	63
<b>DIMENSIONS</b>									
Length	mm	3300	3300	4300	4300	4300	4300	4300	4300
Width	mm	1100	1100	1100	1100	1100	1100	1100	1100
Height	mm	2300	2300	2300	2300	2300	2300	2300	2300

(1) Data based on 7 °C leaving chilled water temperature and 35 °C ambient air temperature.

(2) Data based on 45 °C leaving hot water temperature and 7 °C ambient air temperature with 88 % relative humidity.

(3) Compressors only.

(4) Sound levels are at fully loaded conditions. Sound power level values refer to ISO standard 3744 and Eurovent 8/1.

(5) Sound pressure level values refer to ISO standard 3744, parallelepiped shape.

(\*) High efficiency units (HSE) with inverter fans.

(\*\*) SIF units with high static pressure fans.

# Physical Data - VLH STD/HSE-LN Version

VLH STD/HSE-LN models		524	604	704	804	904	1004	1104	1204
Nominal cooling capacity (1)	kW	130.0	145.9	169.2	191.6	221.2	237.8	262.1	286.2
Input power (3)	kW	47.3	52.5	62.1	68.8	78.3	82.9	97.7	113.8
EER (3)		2.75	2.78	2.72	2.78	2.83	2.87	2.68	2.51
EER (Total unit)		2.62	2.60	2.58	2.65	2.66	2.71	2.56	2.41
ESEER		3.83	3.81	3.78	3.88	3.90	3.98	3.75	3.54
EER (Total unit) (*)		2.68	2.68	2.64	2.71	2.74	2.78	2.62	2.46
ESEER (*)		4.23	4.23	4.17	4.28	4.32	4.39	4.13	3.88
Nominal heating capacity (2)	kW	145.6	164.5	194.2	215.6	246.5	262.1	287.6	320.7
Input power (3)	kW	44.6	51.4	60.6	63.3	71.2	79.1	91.2	103.3
COP (3)		3.26	3.20	3.20	3.41	3.46	3.31	3.15	3.10
Number of refrigerant circuits		2	2	2	2	2	2	2	2
Total capacity steps	%	25-50-75-100	28-57-78-100	20-50-70-100	25-50-75-100	28-50-78-100	25-50-75-100	23-50-73-100	25-50-75-100
<b>COMPRESSORS</b>									
Number		4	4	4	4	4	4	4	4
Type		SCROLL							
Oil type		POE							
N° of loading stages		0/100	0/100	0/100	0/100	0/100	0/100	0/100	0/100
<b>EVAPORATOR</b>									
Number		1	1	1	1	1	1	1	1
Type		PLATE	PLATE	PLATE	PLATE	PLATE	PLATE	PLATE	PLATE
Water volume	litres	11.5	11.5	11.5	13.3	25.2	25.2	25.2	25.2
<b>AIR COOLED CONDENSERS</b>									
Number of coils		2	2	2	2	2	2	2	2
Total coil face area per coil	m <sup>2</sup>	3.5	3.5	4.8	4.8	4.8	4.8	4.8	4.8
<b>FANS</b>									
Number of fans		2	3	3	3	4	4	4	4
Nominal speed	rpm	700	700	700	700	700	700	700	700
Total airflow	m <sup>3</sup> /h	35400	47300	52200	52200	63700	58800	54900	54900
Total input power	kW	2.4	3.6	3.6	3.6	4.8	4.8	4.8	4.8
Total input power (*)	kW	1.2	1.9	1.9	1.9	2.5	2.5	2.5	2.5
External static pressure	Pa	0							
<b>WEIGHT</b>									
Shipping weight	kg	1248	1473	1663	1806	1955	2100	2190	2200
Operating weight	kg	1260	1485	1675	1820	1980	2125	2215	2225
<b>ADDITIONAL WEIGHT</b>									
HSE versions	kg	30	30	30	30	40	40	40	40
Desuperheater versions	kg	20	20	20	30	30	30	30	30
With one pump	kg	50	50	85	85	90	90	95	95
With two pumps	kg	140	140	200	200	205	205	215	215
Copper fins	kg	380	380	520	520	520	700	880	880
<b>SOUND LEVELS</b>									
Sound power level (4)	dB(A)	86	87	87	87	88	88	89	89
Sound pressure level - (10m) (5)	dB(A)	54	55	55	55	56	56	57	57
<b>DIMENSIONS</b>									
Length	mm	3300	3300	4300	4300	4300	4300	4300	4300
Width	mm	1100	1100	1100	1100	1100	1100	1100	1100
Height	mm	2300	2300	2300	2300	2300	2300	2300	2300

(1) Data based on 7 °C leaving chilled water temperature and 35 °C ambient air temperature.

(2) Data based on 45 °C leaving hot water temperature and 7 °C ambient air temperature with 88 % relative humidity.

(3) Compressors only.

(4) Sound levels are at fully loaded conditions. Sound power level values refer to ISO standard 3744 and Eurovent 8/1.

(5) Sound pressure level values refer to ISO standard 3744, parallelepiped shape.

(\*) High efficiency units (HSE) with inverter fans.



# Physical Data - VLH STD/HSE-ELN Version

VLH STD/HSE-ELN models		524	604	704	804	904	1004	1104	1204
Nominal cooling capacity (1)	kW	125.6	142.2	164.6	185.7	214.8	231.0	254.1	276.7
Input power (3)	kW	49.7	54.6	64.9	72.3	81.6	86.3	102.2	119.4
EER (3)		2.53	2.60	2.54	2.57	2.63	2.68	2.49	2.32
EER (Total unit)		2.43	2.47	2.42	2.47	2.51	2.56	2.39	2.24
ESEER		3.79	3.85	3.78	3.84	3.91	3.99	3.73	3.50
EER (Total unit) (*)		2.50	2.56	2.50	2.54	2.59	2.64	2.46	2.29
ESEER (*)		4.14	4.25	4.15	4.21	4.30	4.38	4.08	3.81
Nominal heating capacity (2)	kW	137.1	156.4	183.7	202.4	232.4	244.5	266.3	296.0
Input power (3)	kW	44.6	51.5	60.7	63.1	71.1	78.8	90.1	103.1
COP (3)		3.07	3.04	3.03	3.21	3.27	3.10	2.96	2.87
Number of refrigerant circuits		2	2	2	2	2	2	2	2
Total capacity steps	%	25-50-75-100	28-57-78-100	20-50-70-100	25-50-75-100	28-50-78-100	25-50-75-100	23-50-73-100	25-50-75-100
<b>COMPRESSORS</b>									
Number		4	4	4	4	4	4	4	4
Type		SCROLL							
Oil type		POE							
N° of loading stages		0/100	0/100	0/100	0/100	0/100	0/100	0/100	0/100
<b>EVAPORATOR</b>									
Number		1	1	1	1	1	1	1	1
Type		PLATE	PLATE	PLATE	PLATE	PLATE	PLATE	PLATE	PLATE
Water volume	litres	11.5	11.5	11.5	13.3	25.2	25.2	25.2	25.2
<b>AIR COOLED CONDENSERS</b>									
Number of coils		2	2	2	2	2	2	2	2
Total coil face area per coil	m <sup>2</sup>	3.5	3.5	4.8	4.8	4.8	4.8	4.8	4.8
<b>FANS</b>									
Number of fans		2	3	3	3	4	4	4	4
Nominal speed	rpm	550	550	550	550	550	550	550	550
Total airflow	m <sup>3</sup> /h	28300	38500	41800	41800	52000	48900	46200	46200
Total input power	kW	2	3	3	3	4	4	4	4
Total input power (*)	kW	0.6	0.9	0.9	0.9	1.2	1.2	1.2	1.2
External static pressure	Pa	0							
<b>WEIGHT</b>									
Shipping weight	kg	1278	1508	1698	1841	1990	2140	2230	2240
Operating weight	kg	1290	1520	1710	1855	2015	2165	2255	2265
<b>ADDITIONAL WEIGHT</b>									
HSE versions	kg	30	30	30	30	40	40	40	40
Desuperheater versions	kg	20	20	20	30	30	30	30	30
With one pump	kg	50	50	85	85	90	90	95	95
With two pumps	kg	140	140	200	200	205	205	215	215
Copper fins	kg	380	380	520	520	520	700	880	880
<b>SOUND LEVELS</b>									
Sound power level (4)	dB(A)	83	83	83	83	84	84	85	85
Sound pressure level - (10m) (5)	dB(A)	51	51	51	51	52	52	53	53
<b>DIMENSIONS</b>									
Length	mm	3300	3300	4300	4300	4300	4300	4300	4300
Width	mm	1100	1100	1100	1100	1100	1100	1100	1100
Height	mm	2300	2300	2300	2300	2300	2300	2300	2300

(1) Data based on 7 °C leaving chilled water temperature and 35 °C ambient air temperature.

(2) Data based on 45 °C leaving hot water temperature and 7 °C ambient air temperature with 88 % relative humidity.

(3) Compressors only.

(4) Sound levels are at fully loaded conditions. Sound power level values refer to ISO standard 3744 and Eurovent 8/1.

(5) Sound pressure level values refer to ISO standard 3744, parallelepiped shape.

(\*) High efficiency units (HSE) with inverter fans.

# Physical Data - VLH HT

VLH HT models		524	604	704	804	904	1004	1104	1204
Nominal cooling capacity (1)	kW	135.8	151.7	175.6	199.7	229.5	250.1	276.5	305.6
Input power (3)	kW	44.2	49.2	58.4	64.4	73.2	76.8	89.9	102.8
EER (3)		3.07	3.08	3.01	3.10	3.14	3.26	3.08	2.97
EER (Total unit)		2.79	2.69	2.69	2.80	2.77	2.88	2.77	2.71
Nominal heating capacity (2)	kW	150.9	170.5	200.7	224.0	256.6	273.7	305.5	341.5
Input power (3)	kW	44.6	51.3	60.6	63.5	71.4	79.3	91.4	103.5
COP (3)		3.38	3.32	3.31	3.53	3.59	3.45	3.34	3.30
Number of refrigerant circuits		2	2	2	2	2	2	2	2
Total capacity steps	%	25-50-75-100	28-57-78-100	20-50-70-100	25-50-75-100	28-50-78-100	25-50-75-100	23-50-73-100	25-50-75-100
<b>COMPRESSORS</b>									
Number		4	4	4	4	4	4	4	4
Type		SCROLL							
Oil type		POE							
N° of loading stages		0/100	0/100	0/100	0/100	0/100	0/100	0/100	0/100
<b>EVAPORATOR</b>									
Number		1	1	1	1	1	1	1	1
Type		PLATE	PLATE	PLATE	PLATE	PLATE	PLATE	PLATE	PLATE
Water volume	litres	11.5	11.5	11.5	13.3	25.2	25.2	25.2	25.2
<b>AIR COOLED CONDENSERS</b>									
Number of coils		2	2	2	2	2	2	2	2
Total coil face area per coil	m <sup>2</sup>	3.5	3.5	4.8	4.8	4.8	4.8	4.8	4.8
<b>FANS</b>									
Number of fans		2	3	3	3	4	4	4	4
Nominal speed	rpm	1110	1110	1110	1110	1110	1110	1110	1110
Total airflow	m <sup>3</sup> /h	51700	71800	76200	76200	95800	91200	87600	87600
Total input power (*)	kW	4.5	7.2	6.9	6.9	9.6	9.9	10	10
External static pressure	Pa	0							
<b>WEIGHT</b>									
Shipping weight	kg	1278	1503	1693	1836	1995	2140	2230	2240
Operating weight	kg	1290	1515	1705	1850	2020	2165	2255	2265
<b>ADDITIONAL WEIGHT</b>									
Desuperheater versions	kg	20	20	20	30	30	30	30	30
With one pump	kg	50	50	85	85	90	90	95	95
With two pumps	kg	140	140	200	200	205	205	215	215
Copper fins	kg	380	380	520	520	520	700	880	880
<b>SOUND LEVELS</b>									
Sound power level (4)	dB(A)	97	99	99	99	100	100	100	100
Sound pressure level - (10m) (5)	dB(A)	65	67	67	67	68	68	68	68
<b>DIMENSIONS</b>									
Length	mm	3300	3300	4300	4300	4300	4300	4300	4300
Width	mm	1100	1100	1100	1100	1100	1100	1100	1100
Height	mm	2300	2300	2300	2300	2300	2300	2300	2300

(1) Data based on 7 °C leaving chilled water temperature and 35 °C ambient air temperature.

(2) Data based on 45 °C leaving hot water temperature and 7 °C ambient air temperature with 88 % relative humidity.

(3) Compressors only.

(4) Sound levels are at fully loaded conditions (high temperature version unit). Sound power level values refer to ISO standard 3744 and Eurovent 8/1.

(5) Sound pressure level values refer to ISO standard 3744, parallelepiped shape.

(\*) High temperature units (HT) with inverter fans.

# Physical Data - VLR

VLR models		524	604	704	804	904	1004	1104	1204
Nominal cooling capacity (1)	kW	136.0	152.0	176.0	200.0	230.0	250.0	277.0	306.0
Input power (2)	kW	44.5	49.0	58.5	64.5	73.5	77.0	90.0	103.0
EER (2)		3.06	3.10	3.01	3.10	3.13	3.25	3.08	2.97
Total Heat rejection	kW	171.5	191.0	222.8	251.3	288.3	310.7	348.7	388.6
Number of refrigerant circuits		2	2	2	2	2	2	2	2
Total capacity steps	%	25-50-75-100	28-57-78-100	20-50-70-100	25-50-75-100	28-50-78-100	25-50-75-100	23-50-73-100	25-50-75-100
<b>COMPRESSORS</b>									
Number		4	4	4	4	4	4	4	4
Type		SCROLL							
Oil type		POE							
N° of loading stages		0/100	0/100	0/100	0/100	0/100	0/100	0/100	0/100
<b>EVAPORATOR</b>									
Number		1	1	1	1	1	1	1	1
Type		PLATE	PLATE	PLATE	PLATE	PLATE	PLATE	PLATE	PLATE
Water volume	litres	11.5	11.5	11.5	13.3	25.2	25.2	25.2	25.2
<b>HEAT RECOVERY CONDENSER</b>									
Number		1	1	1	1	1	1	1	1
Type		PLATE	PLATE	PLATE	PLATE	PLATE	PLATE	PLATE	PLATE
Water volume	litres	11.5	11.5	11.5	13.3	25.2	25.2	25.2	25.2
Inlet /outlet water connection	Inch	2" 1/2	2" 1/2	2" 1/2	2" 1/2	3"	3"	3"	3"
<b>WEIGHT</b>									
Shipping weight	kg	1290	1513	1702	1853	2051	2180	2270	2279
Operating weight	kg	1313	1536	1725	1880	2101	2230	2320	2329
<b>ADDITIONAL WEIGHT</b>									
ELN versions	kg	30	35	35	35	35	40	40	40
HSE/SIF/HT versions	kg	30	30	30	30	40	40	40	40
<b>DIMENSIONS</b>									
Length	mm	3300	3300	4300	4300	4300	4300	4300	4300
Width	mm	1100	1100	1100	1100	1100	1100	1100	1100
Height	mm	2300	2300	2300	2300	2300	2300	2300	2300

(1) Data based on 7 °C leaving chilled water temperature and 45 °C condenser water temperature.

(2) Compressors only.

# Electrical Data - VLS & VLH STD Units

## Compressors @ 400 V / 3 Ph / 50 Hz

Models		Power input at nominal conditions per compressor (kW)	Current at nominal conditions per compressor (A)	Power input at max. conditions per compressor (kW)	Current at max. conditions per compressor FLA (A)	Start up current LRA (A)	Power factor at nominal conditions	Unit fuse size (A)	Cable section (mm <sup>2</sup> )
524	Circuit 1	11.5	20	14.0	35.0	158	0.83	200	3 x 95
		11.5	20	14.0	35.0	158	0.83		
	Circuit 2	11.5	20	14.0	35.0	158	0.83		
		11.5	20	14.0	35.0	158	0.83		
604	Circuit 1	12.5	22	15.9	36.0	160	0.82	200	3 x 95
		12.5	22	15.9	36.0	160	0.82		
	Circuit 2	12.5	22	15.9	36.0	160	0.82		
		12.5	22	15.9	36.0	160	0.82		
704	Circuit 1	12.5	22	15.9	36.0	160	0.82	250	3 x 120
		17.2	28	21.5	51.0	215	0.89		
	Circuit 2	12.5	22	15.9	36.0	160	0.82		
		17.2	28	21.5	51.0	215	0.89		
804	Circuit 1	15.9	27	22.6	40.0	225	0.85	250	3 x 120
		15.9	27	22.6	40.0	225	0.85		
	Circuit 2	15.9	27	22.6	40.0	225	0.85		
		15.9	27	22.6	40.0	225	0.85		
904	Circuit 1	15.9	27	22.6	40.0	225	0.85	250	3 x 120
		22.3	36	26.0	48.5	272	0.89		
	Circuit 2	15.9	27	22.6	40.0	225	0.85		
		22.3	36	26.0	48.5	272	0.89		
1004	Circuit 1	22.3	36	26.0	48.5	272	0.89	250	3 x 120
		22.3	36	26.0	48.5	272	0.89		
	Circuit 2	22.3	36	26.0	48.5	272	0.89		
		22.3	36	26.0	48.5	272	0.89		
1104	Circuit 1	22.3	36	26.0	48.5	272	0.89	315	3 x 185
		22.3	36	26.0	48.5	272	0.89		
	Circuit 2	25.5	42	35.0	63.0	310	0.88		
		25.5	42	35.0	63.0	310	0.88		
1204	Circuit 1	25.5	42	35.0	63.0	310	0.88	315	3 x 185
		25.5	42	35.0	63.0	310	0.88		
	Circuit 2	25.5	42	35.0	63.0	310	0.88		
		25.5	42	35.0	63.0	310	0.88		

**Note :** The dimensioning of the unit's power cables is the responsibility of the installer, who shall consider : the rating, the maximum working temperature in the room, the type of insulation and the cable laying, the maximum length of the power supply line.

## Fans - 400 V / 3 Ph / 50 Hz

VLS/VLH BLN models		524	604	704	804	904	1004	1104	1204
Number of fans		2	3	3	3	4	4	4	4
Nominal power per fan	kW	2.0	2.0	2.0	2.0	2.0	2.0	2.0	2.0
Max. running current per fan	A	4.0	4.0	4.0	4.0	4.0	4.0	4.0	4.0
Total fan power	kW	4.0	6.0	6.0	6.0	8.0	8.0	8.0	8.0
Total max. fan current	A	8.0	12.0	12.0	12.0	16.0	16.0	16.0	16.0

VLS/VLH LN models		524	604	704	804	904	1004	1104	1204
Number of fans		2	3	3	3	4	4	4	4
Nominal power per fan	kW	1.25	1.25	1.25	1.25	1.25	1.25	1.25	1.25
Max. running current per fan	A	2.3	2.3	2.3	2.3	2.3	2.3	2.3	2.3
Total fan power	kW	2.5	3.75	3.8	3.8	5.0	5.0	5.0	5.0
Total max. fan current	A	4.6	6.9	6.9	6.9	9.2	9.2	9.2	9.2

## Electrical Data - VLS & VLH STD Units (continued)

### Fans - 400 V / 3 Ph / 50 Hz (continued)

VLS/VLH ELN models		524	604	704	804	904	1004	1104	1204
Number of fans		2	3	3	3	4	4	4	4
Nominal power per fan	kW	1.25	1.25	1.25	1.25	1.25	1.25	1.25	1.25
Max. running current per fan	A	2.3	2.3	2.3	2.3	2.3	2.3	2.3	2.3
Total fan power	kW	2.5	3.75	3.8	3.8	5.0	5.0	5.0	5.0
Total max. fan current	A	4.6	6.9	6.9	6.9	9.2	9.2	9.2	9.2

### Units - 400 V / 3 Ph / 50 Hz

VLS/VLH BLN models		524	604	704	804	904	1004	1104	1204
Nominal power input	kW	50.0	56.0	65.4	69.6	84.4	97.2	103.6	110.0
Maximum power input	kW	60.0	69.6	80.8	96.4	105.2	112.0	130.0	148.0
Nominal current input	A	88.0	100.0	112.0	120.0	142.0	160.0	172.0	184.0
Maximum current input	A	148.0	156.0	186.0	172.0	193.0	210.0	239.0	268.0
Start-up current	A	271	280	350	357	378	434	486	515

VLS/VLH LN models		524	604	704	804	904	1004	1104	1204
Nominal power input	kW	48.5	53.8	63.2	67.4	81.4	94.2	100.6	107.0
Maximum power input	kW	58.5	67.4	78.6	94.2	102.2	109.0	127.0	145.0
Nominal current input	A	84.6	94.9	106.9	114.9	135.2	153.2	165.2	177.2
Maximum current input	A	144.6	150.9	180.9	166.9	186.2	203.2	232.2	261.2
Start-up current	A	268	275	345	352	371	427	479	508

VLS/VLH ELN models		524	604	704	804	904	1004	1104	1204
Nominal power input	kW	48.5	53.8	63.2	67.4	81.4	94.2	100.6	107.0
Maximum power input	kW	58.5	67.4	78.6	94.2	102.2	109.0	127.0	145.0
Nominal current input	A	84.6	94.9	106.9	114.9	135.2	153.2	165.2	177.2
Maximum current input	A	144.6	150.9	180.9	166.9	186.2	203.2	232.2	261.2
Start-up current	A	267.6	275	345	352	371	427	479	508

# Electrical Data - VLS & VLH HSE/SIF/HT Units

## Compressors @ 400 V / 3 Ph / 50 Hz

Models		Power input at nominal conditions per compressor (kW)	Current at nominal conditions per compressor (A)	Power input at max. conditions per compressor (kW)	Current at max. conditions per compressor FLA (A)	Start up current LRA (A)	Power factor at nominal conditions	Unit fuse size (A)	Cable section (mm <sup>2</sup> )
524	Circuit 1	11.5	20	14.0	35.0	158	0.83	200	3 x 95
		11.5	20	14.0	35.0	158	0.83		
	Circuit 2	11.5	20	14.0	35.0	158	0.83		
		11.5	20	14.0	35.0	158	0.83		
604	Circuit 1	12.5	22	15.9	36.0	160	0.82	200	3 x 95
		12.5	22	15.9	36.0	160	0.82		
	Circuit 2	12.5	22	15.9	36.0	160	0.82		
		12.5	22	15.9	36.0	160	0.82		
704	Circuit 1	12.5	22	15.9	36.0	160	0.82	250	3 x 120
		17.2	28	21.5	51.0	215	0.89		
	Circuit 2	12.5	22	15.9	36.0	160	0.82		
		17.2	28	21.5	51.0	215	0.89		
804	Circuit 1	15.9	27	22.6	40.0	225	0.85	250	3 x 120
		15.9	27	22.6	40.0	225	0.85		
	Circuit 2	15.9	27	22.6	40.0	225	0.85		
		15.9	27	22.6	40.0	225	0.85		
904	Circuit 1	15.9	27	22.6	40.0	225	0.85	250	3 x 120
		22.3	36	26.0	48.5	272	0.89		
	Circuit 2	15.9	27	22.6	40.0	225	0.85		
		22.3	36	26.0	48.5	272	0.89		
1004	Circuit 1	22.3	36	26.0	48.5	272	0.89	250	3 x 120
		22.3	36	26.0	48.5	272	0.89		
	Circuit 2	22.3	36	26.0	48.5	272	0.89		
		22.3	36	26.0	48.5	272	0.89		
1104	Circuit 1	22.3	36	26.0	48.5	272	0.89	315	3 x 185
		22.3	36	26.0	48.5	272	0.89		
	Circuit 2	25.5	42	35.0	63.0	310	0.88		
		25.5	42	35.0	63.0	310	0.88		
1204	Circuit 1	25.5	42	35.0	63.0	310	0.88	315	3 x 185
		25.5	42	35.0	63.0	310	0.88		
	Circuit 2	25.5	42	35.0	63.0	310	0.88		
		25.5	42	35.0	63.0	310	0.88		

**Note :** The dimensioning of the unit's power cables is the responsibility of the installer, who shall consider : the rating, the maximum working temperature in the room, the type of insulation and the cable laying, the maximum length of the power supply line.

## Fans - 400 V / 3 Ph / 50 Hz

VLS/VLH BLN models		524	604	704	804	904	1004	1104	1204
Number of fans		2	3	3	3	4	4	4	4
Nominal power per fan	kW	2.6	2.6	2.6	2.6	2.6	2.6	2.6	2.6
Max. running current per fan	A	4.1	4.1	4.1	4.1	4.1	4.1	4.1	4.1
Total fan power	kW	5.2	7.8	7.8	7.8	10.4	10.4	10.4	10.4
Total max. fan current	A	8.2	12.3	12.3	12.3	16.4	16.4	16.4	16.4

VLS/VLH LN models		524	604	704	804	904	1004	1104	1204
Number of fans		2	3	3	3	4	4	4	4
Nominal power per fan	kW	2.6	2.6	2.6	2.6	2.6	2.6	2.6	2.6
Max. running current per fan	A	4.1	4.1	4.1	4.1	4.1	4.1	4.1	4.1
Total fan power	kW	5.2	7.8	7.8	7.8	10.4	10.4	10.4	10.4
Total max. fan current	A	8.2	12.3	12.3	12.3	16.4	16.4	16.4	16.4

## Electrical Data - VLS & VLH HSE/SIF/HT Units (continued)

### Fans - 400 V / 3 Ph / 50 Hz (continued)

VLS/VLH ELN models		524	604	704	804	904	1004	1104	1204
Number of fans		2	3	3	3	4	4	4	4
Nominal power per fan	kW	2.6	2.6	2.6	2.6	2.6	2.6	2.6	2.6
Max. running current per fan	A	4.1	4.1	4.1	4.1	4.1	4.1	4.1	4.1
Total fan power	kW	5.2	7.8	7.8	7.8	10.4	10.4	10.4	10.4
Total max. fan current	A	8.2	12.3	12.3	12.3	16.4	16.4	16.4	16.4

### Units - 400 V / 3 Ph / 50 Hz

VLS/VLH BLN models		524	604	704	804	904	1004	1104	1204
Nominal power input	kW	51.2	57.8	67.2	71.4	86.8	99.6	106.0	112.4
Maximum power input	kW	61.2	71.4	82.6	98.2	107.6	114.4	132.4	150.4
Nominal current input	A	88.2	100.3	112.3	120.3	142.4	160.4	172.4	184.4
Maximum current input	A	148.2	156.3	186.3	172.3	193.4	210.4	239.4	268.4
Start-up current	A	271	280	350	357	378	434	486	515

VLS/VLH LN models		524	604	704	804	904	1004	1104	1204
Nominal power input	kW	51.2	57.8	67.2	71.4	86.8	99.6	106.0	112.4
Maximum power input	kW	61.2	71.4	82.6	98.2	107.6	114.4	132.4	150.4
Nominal current input	A	88.2	100.3	112.3	120.3	142.4	160.4	172.4	184.4
Maximum current input	A	148.2	156.3	186.3	172.3	193.4	210.4	239.4	268.4
Start-up current	A	271	280	350	357	378	434	486	515

VLS/VLH ELN models		524	604	704	804	904	1004	1104	1204
Nominal power input	kW	51.2	57.8	67.2	71.4	86.8	99.6	106.0	112.4
Maximum power input	kW	61.2	71.4	82.6	98.2	107.6	114.4	132.4	150.4
Nominal current input	A	88.2	100.3	112.3	120.3	142.4	160.4	172.4	184.4
Maximum current input	A	148.2	156.3	186.3	172.3	193.4	210.4	239.4	268.4
Start-up current	A	271	280	350	357	378	434	486	515

## Sound Levels - VLS/VLH Units

		Frequency (Hz)							Sound Power dB(A)	Sound Pressure dB(A)(*)
		125	250	500	1000	2000	4000	8000		
VLS/VLH BLN	524	86.0	85.0	93.0	87.0	81.0	66.0	54.0	92	60
	604	87.0	86.0	94.0	88.0	82.0	67.0	55.0	93	61
	704	87.0	86.0	94.0	88.0	82.0	67.0	55.0	93	61
	804	87.0	86.0	94.0	88.0	82.0	67.0	55.0	93	61
	904	88.0	87.0	95.0	89.0	83.0	68.0	56.0	94	62
	1004	88.0	87.0	95.0	89.0	83.0	68.0	56.0	94	62
	1104	89.0	88.0	96.0	90.0	84.0	69.0	57.0	95	63
	1204	89.0	88.0	96.0	90.0	84.0	69.0	57.0	95	63
VLS/VLH LN	524	80.0	79.0	87.0	81.0	75.0	60.0	48.0	86	54
	604	81.0	80.0	88.0	82.0	76.0	61.0	49.0	87	55
	704	81.0	80.0	88.0	82.0	76.0	61.0	49.0	87	55
	804	81.0	80.0	88.0	82.0	76.0	61.0	49.0	87	55
	904	82.0	81.0	89.0	83.0	77.0	62.0	50.0	88	56
	1004	82.0	81.0	89.0	83.0	77.0	62.0	50.0	88	56
	1104	83.0	82.0	90.0	84.0	78.0	63.0	51.0	89	57
	1204	83.0	82.0	90.0	84.0	78.0	63.0	51.0	89	57
VLS/VLH ELN	524	77.0	76.0	84.0	78.0	72.0	57.0	45.0	83	51
	604	77.0	76.0	84.0	78.0	72.0	57.0	45.0	83	51
	704	77.0	76.0	84.0	78.0	72.0	57.0	45.0	83	51
	804	77.0	76.0	84.0	78.0	72.0	57.0	45.0	83	51
	904	78.0	77.0	85.0	79.0	73.0	58.0	46.0	84	52
	1004	78.0	77.0	85.0	79.0	73.0	58.0	46.0	84	52
	1104	79.0	78.0	86.0	80.0	74.0	59.0	47.0	85	53
	1204	79.0	78.0	86.0	80.0	74.0	59.0	47.0	85	53
VLS/VLH HT (**)	524	91.0	90.0	98.0	92.0	86.0	71.0	59.0	97	65
	604	93.0	92.0	100.0	94.0	88.0	73.0	61.0	99	67
	704	93.0	92.0	100.0	94.0	88.0	73.0	61.0	99	67
	804	93.0	92.0	100.0	94.0	88.0	73.0	61.0	99	67
	904	94.0	93.0	101.0	95.0	89.0	74.0	62.0	100	68
	1004	94.0	93.0	101.0	95.0	89.0	74.0	62.0	100	68
	1104	94.0	93.0	101.0	95.0	89.0	74.0	62.0	100	68
	1204	94.0	93.0	101.0	95.0	89.0	74.0	62.0	100	68

(\*) Sound pressure levels are given at 10 meters distance according to ISO standard 3744 with parallelepiped shape.

(\*\*) Sound data is given at maximum operating air temperature. For nominal condition, please refer to sound data of BLN version.



# Cooling Capacities - VLS STD/HSE/SIF-BLN Version

VLS STD/HSE/ SIF models	LWT (°C)	Condenser entering air temperature (°C)													
		25		30		32		35		40		44		46	
		Cool. cap. (kW)	Input power (kW)	Cool. cap. (kW)	Input power (kW)	Cool. cap. (kW)	Input power (kW)	Cool. cap. (kW)	Input power (kW)	Cool. cap. (kW)	Input power (kW)	Cool. cap. (kW)	Input power (kW)	Cool. cap. (kW)	Input power (kW)
524 BLN	5	143.1	36.7	136.3	40.3	133.4	41.8	128.9	44.0	119.8	48.9	114.2	52.0	108.6	55.2
	6	147.4	37.1	140.2	40.8	137.3	42.3	132.7	44.5	123.4	49.4	117.6	52.6	111.9	55.7
	7	151.7	37.6	144.3	41.2	141.3	42.8	<b>136.6</b>	<b>45.0</b>	126.9	49.9	121.0	53.1	115.1	56.3
	8	155.5	38.1	148.0	41.7	144.9	43.2	140.0	45.5	130.2	50.4	124.1	53.6	118.0	56.8
	9	159.4	38.5	151.6	42.2	148.4	43.7	143.6	46.0	133.5	50.9	127.2	54.1	121.0	57.3
	10	163.2	39.0	155.3	42.7	152.0	44.2	147.0	46.5	136.5	51.4	130.2	54.7	123.8	57.9
	12	171.0	40.0	162.7	43.7	159.3	45.2	154.0	47.5	143.1	52.6	136.4	55.8	129.7	59.1
15	182.6	41.5	173.9	45.2	170.2	46.8	164.4	49.2	152.9	54.2	145.7	57.5	138.5	60.8	
604 BLN	5	161.7	40.6	153.9	44.5	150.6	46.2	145.6	48.6	135.4	54.0	129.0	57.5	122.7	60.9
	6	166.5	41.0	158.4	45.0	155.1	46.7	149.9	49.2	139.4	54.6	132.9	58.1	126.3	61.5
	7	171.4	41.5	163.0	45.6	159.6	47.2	<b>154.3</b>	<b>49.7</b>	143.4	55.1	136.7	58.6	130.0	62.1
	8	175.7	42.0	167.2	46.1	163.7	47.7	158.2	50.3	147.1	55.7	140.2	59.2	133.3	62.7
	9	180.0	42.5	171.3	46.6	167.6	48.3	162.2	50.8	150.8	56.2	143.7	59.8	136.7	63.3
	10	184.3	43.1	175.4	47.1	171.7	48.8	166.0	51.4	154.2	56.8	147.0	60.4	139.9	63.9
	12	193.1	44.1	183.7	48.3	179.9	49.9	173.9	52.5	161.6	58.0	154.1	61.6	146.5	65.3
15	206.3	45.8	196.4	49.9	192.2	51.7	185.7	54.3	172.7	59.8	164.6	63.5	156.5	67.2	
704 BLN	5	185.4	48.5	176.5	53.2	172.7	55.2	166.9	58.1	155.2	64.6	147.9	68.7	140.7	72.8
	6	190.9	49.0	181.6	53.8	177.8	55.8	171.8	58.8	159.8	65.2	152.3	69.4	144.9	73.6
	7	196.5	49.6	186.9	54.4	182.9	56.4	<b>176.9</b>	<b>59.4</b>	164.4	65.9	156.7	70.1	149.1	74.3
	8	201.4	50.2	191.7	55.0	187.6	57.0	181.3	60.1	168.6	66.5	160.7	70.7	152.9	75.0
	9	206.4	50.8	196.4	55.7	192.1	57.7	185.9	60.7	172.8	67.2	164.8	71.4	156.7	75.6
	10	211.3	51.5	201.1	56.3	196.8	58.4	190.4	61.4	176.8	67.9	168.6	72.1	160.4	76.4
	12	221.4	52.7	210.6	57.7	206.3	59.7	199.4	62.7	185.3	69.4	176.6	73.7	167.9	78.0
15	236.5	54.8	225.1	59.7	220.4	61.7	212.9	64.9	198.0	71.5	188.7	75.9	179.4	80.3	
804 BLN	5	208.3	53.5	198.3	58.7	194.1	60.8	187.6	64.1	174.4	71.2	166.3	75.7	158.1	80.3
	6	214.5	54.1	204.1	59.4	199.8	61.5	193.1	64.8	179.6	71.9	171.2	76.5	162.8	81.1
	7	220.8	54.7	210.1	60.0	205.6	62.2	<b>198.8</b>	<b>65.5</b>	184.7	72.7	176.1	77.3	167.5	81.9
	8	226.3	55.4	215.4	60.7	210.9	62.9	203.8	66.2	189.5	73.4	180.6	78.0	171.8	82.6
	9	232.0	56.1	220.7	61.4	215.9	63.6	209.0	66.9	194.2	74.1	185.2	78.8	176.1	83.4
	10	237.5	56.8	226.0	62.1	221.2	64.4	213.9	67.7	198.7	74.9	189.4	79.6	180.2	84.3
	12	248.8	58.2	236.7	63.6	231.8	65.8	224.1	69.2	208.2	76.5	198.5	81.2	188.7	86.0
15	265.8	60.4	253.0	65.8	247.7	68.1	239.3	71.5	222.5	78.9	212.1	83.7	201.6	88.5	
904 BLN	5	239.9	60.9	228.3	66.9	223.5	69.3	216.0	73.0	200.8	81.1	191.4	86.3	182.1	91.4
	6	247.0	61.6	235.0	67.6	230.1	70.1	222.4	73.8	206.8	81.9	197.1	87.2	187.4	92.4
	7	254.2	62.3	241.9	68.4	236.7	70.9	<b>228.9</b>	<b>74.6</b>	212.7	82.8	202.8	88.0	192.9	93.3
	8	260.6	63.1	248.0	69.1	242.8	71.6	234.6	75.4	218.2	83.6	208.0	88.8	197.8	94.1
	9	267.1	63.8	254.1	70.0	248.6	72.5	240.6	76.2	223.7	84.4	213.2	89.7	202.7	95.0
	10	273.5	64.7	260.2	70.7	254.7	73.3	246.3	77.1	228.7	85.3	218.1	90.6	207.5	96.0
	12	286.5	66.2	272.6	72.4	266.9	75.0	258.0	78.8	239.8	87.1	228.5	92.5	217.3	98.0
15	306.0	68.8	291.3	74.9	285.2	77.5	275.5	81.5	256.2	89.8	244.2	95.3	232.2	100.8	
1004 BLN	5	262.9	64.1	250.3	70.4	245.0	72.9	236.8	76.8	220.1	85.3	209.8	90.8	199.6	96.2
	6	270.8	64.8	257.5	71.2	252.2	73.7	243.7	77.7	226.7	86.2	216.1	91.7	205.5	97.2
	7	278.6	65.6	265.1	71.9	259.5	74.6	<b>250.9</b>	<b>78.5</b>	233.2	87.1	222.3	92.6	211.4	98.1
	8	285.6	66.4	271.8	72.7	266.1	75.4	257.2	79.4	239.1	87.9	228.0	93.5	216.8	99.1
	9	292.8	67.2	278.5	73.6	272.5	76.3	263.7	80.2	245.1	88.8	233.7	94.4	222.2	100.0
	10	299.7	68.0	285.3	74.4	279.2	77.1	270.0	81.1	250.7	89.7	239.1	95.3	227.5	101.0
	12	314.0	69.7	298.8	76.2	292.5	78.9	282.8	82.9	262.8	91.7	250.5	97.4	238.2	103.1
15	335.4	72.4	319.3	78.8	312.6	81.6	302.0	85.7	280.9	94.5	267.7	100.3	254.5	106.1	
1104 BLN	5	293.0	74.8	278.9	82.1	273.0	85.1	263.9	89.6	245.3	99.6	233.8	105.9		
	6	301.7	75.6	287.0	83.0	281.1	86.0	271.6	90.7	252.6	100.6	240.8	107.0		
	7	310.5	76.5	295.4	84.0	289.1	87.0	<b>279.6</b>	<b>91.6</b>	259.8	101.6	247.7	108.1		
	8	318.3	77.5	302.9	84.9	296.6	88.0	286.6	92.6	266.5	102.6	254.0	109.1		
	9	326.2	78.4	310.4	85.9	303.7	89.0	293.9	93.6	273.2	103.6	260.4	110.1		
	10	334.0	79.4	317.9	86.8	311.1	90.0	300.9	94.7	279.4	104.7	266.4	111.3		
	12	350.0	81.3	332.9	88.9	326.0	92.0	315.2	96.7	292.9	107.0	279.2	113.6		
15	373.8	84.5	355.8	92.0	348.3	95.2	336.5	100.1	313.0	110.3	298.3	117.0			
1204 BLN	5	322.4	86.7	306.9	95.2	300.4	98.7	290.4	103.9	269.9	115.4	257.3	122.8		
	6	332.1	87.7	315.8	96.3	309.3	99.7	298.9	105.1	278.0	116.6	265.0	124.1		
	7	341.7	88.7	325.1	97.3	318.2	100.9	<b>307.7</b>	<b>106.2</b>	286.0	117.8	272.6	125.3		
	8	350.3	89.8	333.4	98.4	326.4	102.0	315.4	107.4	293.3	118.9	279.6	126.5		
	9	359.0	90.9	341.6	99.6	334.2	103.2	323.4	108.5	300.6	120.2	286.6	127.7		
	10	367.6	92.1	349.8	100.7	342.4	104.4	331.1	109.8	307.5	121.4	293.2	129.0		
	12	385.1	94.3	366.4	103.1	358.8	106.7	346.8	112.1	322.3	124.0	307.2	131.7		
15	411.3	97.9	391.6	106.7	383.3	110.4	370.3	116.0	344.5	127.9	328.3	135.7			

Notes : - LWT : Leaving water temperature.  
 - Power input data are given for compressors only.

# Cooling Capacities - VLS STD/HSE-LN Version

VLS STD/HSE models	LWT (°C)	Condenser entering air temperature (°C)											
		25		30		32		35		40		44	
		Cool. cap. (kW)	Input power (kW)	Cool. cap. (kW)	Input power (kW)	Cool. cap. (kW)	Input power (kW)	Cool. cap. (kW)	Input power (kW)	Cool. cap. (kW)	Input power (kW)	Cool. cap. (kW)	Input power (kW)
524 LN	5	138.5	38.6	131.9	42.4	129.1	43.9	124.8	46.3	116.0	51.4	110.6	54.7
	6	142.7	39.0	135.7	42.9	132.9	44.4	128.4	46.8	119.4	51.9	113.8	55.3
	7	146.8	39.5	139.7	43.4	136.7	44.9	<b>132.2</b>	<b>47.3</b>	122.9	52.5	117.1	55.8
	8	150.5	40.0	143.2	43.8	140.2	45.4	135.5	47.8	126.0	53.0	120.1	56.3
	9	154.3	40.5	146.8	44.4	143.6	46.0	139.0	48.3	129.2	53.5	123.1	56.9
	10	157.9	41.0	150.3	44.8	147.1	46.5	142.3	48.9	132.1	54.1	126.0	57.5
	12	165.5	42.0	157.4	45.9	154.1	47.5	149.0	49.9	138.5	55.2	132.0	58.7
15	176.7	43.6	168.3	47.5	164.7	49.2	159.1	51.7	148.0	57.0	141.0	60.4	
604 LN	5	157.0	42.5	149.4	46.7	146.2	48.4	141.4	51.0	131.4	56.6	125.3	60.2
	6	161.7	43.0	153.8	47.2	150.6	48.9	145.5	51.6	135.3	57.2	129.0	60.9
	7	166.4	43.5	158.3	47.7	154.9	49.5	<b>149.8</b>	<b>52.1</b>	139.2	57.8	132.7	61.5
	8	170.5	44.1	162.3	48.3	158.9	50.0	153.5	52.7	142.8	58.4	136.1	62.0
	9	174.8	44.6	166.3	48.9	162.7	50.6	157.5	53.2	146.4	58.9	139.5	62.7
	10	179.0	45.2	170.3	49.4	166.7	51.2	161.2	53.8	149.7	59.5	142.8	63.3
	12	187.5	46.3	178.4	50.6	174.7	52.4	168.9	55.0	156.9	60.8	149.6	64.6
15	200.3	48.0	190.7	52.3	186.6	54.1	180.3	56.9	167.7	62.7	159.8	66.6	
704 LN	5	180.4	50.8	171.8	55.7	168.1	57.8	162.5	60.9	151.1	67.6	144.0	71.9
	6	185.8	51.3	176.8	56.4	173.1	58.4	167.3	61.6	155.6	68.3	148.3	72.7
	7	191.2	52.0	181.9	57.0	178.1	59.1	<b>172.2</b>	<b>62.2</b>	160.0	69.0	152.6	73.4
	8	196.0	52.6	186.6	57.6	182.6	59.7	176.5	62.9	164.1	69.7	156.5	74.1
	9	200.9	53.2	191.2	58.3	187.0	60.4	181.0	63.5	168.3	70.4	160.4	74.8
	10	205.7	53.9	195.8	59.0	191.6	61.1	185.3	64.3	172.1	71.1	164.1	75.5
	12	215.5	55.2	205.0	60.4	200.8	62.5	194.1	65.7	180.4	72.6	171.9	77.2
15	230.2	57.4	219.2	62.5	214.5	64.6	207.3	67.9	192.8	74.9	183.7	79.5	
804 LN	5	202.3	56.3	192.6	61.8	188.5	64.0	182.2	67.4	169.4	74.9	161.5	79.7
	6	208.4	56.9	198.2	62.5	194.1	64.7	187.6	68.2	174.5	75.7	166.3	80.5
	7	214.4	57.6	204.0	63.1	199.7	65.5	<b>193.1</b>	<b>68.9</b>	179.5	76.5	171.1	81.3
	8	219.8	58.3	209.2	63.8	204.8	66.2	197.9	69.7	184.0	77.2	175.4	82.1
	9	225.3	59.0	214.4	64.6	209.7	66.9	203.0	70.4	188.7	78.0	179.8	82.9
	10	230.7	59.7	219.5	65.3	214.9	67.7	207.8	71.2	193.0	78.7	184.0	83.7
	12	241.7	61.2	229.9	66.9	225.1	69.2	217.7	72.7	202.3	80.5	192.8	85.5
15	258.1	63.5	245.8	69.2	240.6	71.6	232.4	75.3	216.2	83.0	206.0	88.0	
904 LN	5	233.5	64.0	222.3	70.3	217.5	72.8	210.3	76.7	195.5	85.2	186.3	90.6
	6	240.4	64.7	228.7	71.1	224.0	73.6	216.4	77.6	201.3	86.1	191.9	91.6
	7	247.4	65.5	235.4	71.9	230.4	74.5	<b>222.8</b>	<b>78.4</b>	207.1	87.0	197.4	92.5
	8	253.6	66.3	241.4	72.6	236.3	75.3	228.4	79.3	212.3	87.8	202.4	93.4
	9	260.0	67.1	247.3	73.5	242.0	76.2	234.2	80.1	217.7	88.7	207.5	94.3
	10	266.2	68.0	253.3	74.3	247.9	77.0	239.8	81.0	222.6	89.6	212.3	95.2
	12	278.9	69.6	265.3	76.1	259.8	78.8	251.1	82.8	233.4	91.6	222.4	97.2
15	297.8	72.3	283.6	78.7	277.6	81.5	268.2	85.6	249.4	94.4	237.7	100.2	
1004 LN	5	253.2	67.8	241.0	74.5	235.9	77.2	228.0	81.3	212.0	90.3	202.1	96.1
	6	260.7	68.6	248.0	75.3	242.9	78.0	234.7	82.3	218.3	91.3	208.1	97.1
	7	268.3	69.4	255.3	76.2	249.9	79.0	<b>241.6</b>	<b>83.1</b>	224.5	92.2	214.1	98.0
	8	275.0	70.3	261.8	77.0	256.3	79.8	247.6	84.0	230.3	93.1	219.5	99.0
	9	281.9	71.1	268.2	77.9	262.4	80.7	253.9	84.9	236.1	94.0	225.0	99.9
	10	288.6	72.0	274.7	78.8	268.8	81.7	260.0	85.9	241.4	95.0	230.2	100.9
	12	302.4	73.8	287.7	80.7	281.7	83.5	272.3	87.7	253.1	97.0	241.2	103.1
15	323.0	76.6	307.5	83.5	301.0	86.4	290.8	90.8	270.5	100.1	257.7	106.2	
1104 LN	5	280.0	80.2	266.5	88.0	260.9	91.2	252.2	96.1	234.4	106.7		
	6	288.4	81.1	274.3	89.0	268.6	92.2	259.6	97.2	241.4	107.8		
	7	296.7	82.1	282.3	90.0	276.3	93.3	<b>267.2</b>	<b>98.2</b>	248.3	109.0		
	8	304.2	83.0	289.5	91.0	283.4	94.3	273.9	99.3	254.7	110.0		
	9	311.8	84.0	296.6	92.1	290.2	95.4	280.8	100.3	261.1	111.1		
	10	319.2	85.1	303.8	93.1	297.3	96.5	287.5	101.5	267.0	112.2		
	12	334.4	87.2	318.2	95.4	311.5	98.7	301.2	103.7	279.9	114.7		
15	357.2	90.6	340.1	98.6	332.9	102.1	321.6	107.3	299.1	118.2			
1204 LN	5	306.8	93.5	292.1	102.6	285.9	106.4	276.3	112.1	256.9	124.4		
	6	316.0	94.5	300.5	103.8	294.3	107.5	284.4	113.3	264.5	125.7		
	7	325.2	95.7	309.4	104.9	302.8	108.8	<b>292.8</b>	<b>114.5</b>	272.1	127.1		
	8	333.3	96.8	317.2	106.1	310.6	110.0	300.1	115.8	279.1	128.2		
	9	341.7	98.0	325.0	107.4	318.0	111.2	307.8	116.9	286.1	129.6		
	10	349.8	99.3	332.9	108.5	325.8	112.5	315.1	118.3	292.6	130.9		
	12	366.5	101.7	348.7	111.2	341.4	115.1	330.1	120.9	306.7	133.7		
15	391.4	105.6	372.6	115.0	364.8	119.0	352.4	125.1	327.8	137.9			

Notes : - LWT : Leaving water temperature.  
 - Power input data are given for compressors only.

# Cooling Capacities - VLS STD/HSE-ELN Version

VLS STD/HSE models	LWT (°C)	Condenser entering air temperature (°C)									
		25		30		32		35		40	
		Cool. cap. (kW)	Input power (kW)	Cool. cap. (kW)	Input power (kW)	Cool. cap. (kW)	Input power (kW)	Cool. cap. (kW)	Input power (kW)	Cool. cap. (kW)	Input power (kW)
524 ELN	5	133.8	40.6	127.4	44.5	124.7	46.2	120.5	48.6	112.0	54.0
	6	137.8	41.0	131.1	45.0	128.4	46.7	124.1	49.2	115.4	54.6
	7	141.8	41.5	134.9	45.6	132.1	47.2	<b>127.7</b>	<b>49.7</b>	118.7	55.1
	8	145.4	42.0	138.4	46.1	135.4	47.7	130.9	50.3	121.7	55.7
	9	149.0	42.5	141.8	46.6	138.7	48.3	134.2	50.8	124.8	56.2
	10	152.6	43.1	145.2	47.1	142.1	48.8	137.4	51.4	127.6	56.8
	12	159.8	44.1	152.1	48.3	148.9	49.9	143.9	52.5	133.8	58.0
15	170.7	45.8	162.5	49.9	159.1	51.7	153.7	54.3	143.0	59.8	
604 ELN	5	153.0	44.3	145.6	48.6	142.5	50.4	137.8	53.0	128.1	58.9
	6	157.6	44.7	149.9	49.1	146.8	50.9	141.8	53.7	131.9	59.5
	7	162.1	45.3	154.3	49.7	151.0	51.5	<b>146.0</b>	<b>54.2</b>	135.7	60.1
	8	166.2	45.8	158.2	50.2	154.9	52.1	149.7	54.8	139.2	60.7
	9	170.4	46.4	162.1	50.8	158.6	52.7	153.5	55.4	142.7	61.3
	10	174.4	47.0	166.0	51.4	162.5	53.3	157.1	56.0	145.9	61.9
	12	182.7	48.1	173.9	52.6	170.2	54.5	164.6	57.2	152.9	63.3
15	195.2	50.0	185.8	54.4	181.9	56.3	175.7	59.2	163.4	65.3	
704 ELN	5	175.2	53.2	166.8	58.3	163.2	60.5	157.8	63.7	146.7	70.8
	6	180.4	53.7	171.6	59.0	168.1	61.1	162.4	64.4	151.1	71.5
	7	185.7	54.4	176.7	59.7	172.9	61.9	<b>167.2</b>	<b>65.1</b>	155.4	72.2
	8	190.3	55.1	181.2	60.3	177.3	62.5	171.4	65.8	159.4	72.9
	9	195.1	55.7	185.6	61.0	181.6	63.2	175.7	66.5	163.4	73.7
	10	199.7	56.4	190.1	61.7	186.0	64.0	179.9	67.3	167.1	74.4
	12	209.3	57.8	199.1	63.2	194.9	65.4	188.5	68.7	175.1	76.0
15	223.5	60.0	212.8	65.4	208.3	67.7	201.2	71.1	187.2	78.4	
804 ELN	5	195.7	59.1	186.3	64.9	182.4	67.3	176.3	70.9	163.9	78.7
	6	201.6	59.8	191.7	65.6	187.8	68.0	181.5	71.7	168.8	79.5
	7	207.5	60.5	197.4	66.4	193.2	68.8	<b>186.8</b>	<b>72.4</b>	173.6	80.3
	8	212.7	61.2	202.4	67.1	198.1	69.5	191.5	73.2	178.0	81.1
	9	218.0	62.0	207.4	67.9	202.9	70.3	196.3	73.9	182.5	81.9
	10	223.2	62.8	212.4	68.6	207.9	71.1	201.0	74.8	186.7	82.7
	12	233.8	64.3	222.4	70.3	217.8	72.8	210.6	76.4	195.7	84.5
15	249.7	66.8	237.7	72.7	232.7	75.2	224.8	79.1	209.1	87.2	
904 ELN	5	227.1	66.8	216.2	73.3	211.6	76.0	204.5	80.1	190.1	88.9
	6	233.9	67.5	222.4	74.1	217.8	76.8	210.5	81.0	195.8	89.8
	7	240.7	68.4	229.0	75.0	224.1	77.7	<b>216.7</b>	<b>81.8</b>	201.4	90.8
	8	246.7	69.2	234.8	75.8	229.8	78.6	222.1	82.7	206.5	91.6
	9	252.9	70.0	240.6	76.7	235.4	79.5	227.8	83.5	211.7	92.6
	10	258.9	70.9	246.4	77.5	241.1	80.4	233.2	84.5	216.5	93.5
	12	271.2	72.6	258.0	79.4	252.7	82.2	244.3	86.4	227.0	95.5
15	289.7	75.4	275.8	82.2	270.0	85.0	260.8	89.3	242.6	98.5	
1004 ELN	5	245.9	70.7	234.1	77.6	229.1	80.5	221.5	84.8	205.9	94.1
	6	253.3	71.5	240.9	78.5	235.9	81.3	228.0	85.7	212.1	95.1
	7	260.6	72.4	248.0	79.4	242.7	82.3	<b>234.7</b>	<b>86.6</b>	218.1	96.1
	8	267.2	73.2	254.3	80.2	248.9	83.2	240.6	87.6	223.7	97.0
	9	273.9	74.1	260.5	81.2	254.9	84.1	246.7	88.4	229.3	98.0
	10	280.4	75.1	266.8	82.1	261.2	85.1	252.6	89.5	234.5	99.0
	12	293.8	76.9	279.5	84.1	273.6	87.0	264.6	91.4	245.9	101.1
15	313.7	79.9	298.7	87.0	292.4	90.0	282.5	94.6	262.7	104.3	
1104 ELN	5	271.2	83.8	258.2	92.0	252.7	95.3	244.2	100.4		
	6	279.3	84.7	265.6	93.0	260.2	96.4	251.4	101.6		
	7	287.4	85.7	273.5	94.0	267.6	97.5	<b>258.8</b>	<b>102.6</b>		
	8	294.6	86.8	280.4	95.1	274.5	98.5	265.3	103.7		
	9	302.0	87.8	287.3	96.2	281.1	99.7	272.0	104.8		
	10	309.2	88.9	294.2	97.2	288.0	100.8	278.5	106.0		
	12	323.9	91.1	308.2	99.6	301.7	103.1	291.7	108.3		
15	346.0	94.6	329.4	103.1	322.4	106.6	311.5	112.1			
1204 ELN	5	296.4	98.0	282.2	107.6	276.2	111.5	267.0	117.4		
	6	305.3	99.1	290.4	108.8	284.4	112.7	274.8	118.8		
	7	314.2	100.3	298.9	110.0	292.6	114.0	<b>282.9</b>	<b>120.0</b>		
	8	322.1	101.5	306.5	111.2	300.1	115.2	290.0	121.3		
	9	330.1	102.7	314.0	112.5	307.3	116.6	297.4	122.6		
	10	338.0	104.0	321.6	113.7	314.8	117.9	304.4	124.0		
	12	354.1	106.6	336.9	116.5	329.8	120.6	318.9	126.7		
15	378.2	110.7	360.0	120.5	352.4	124.7	340.5	131.1			

Notes : - LWT : Leaving water temperature.  
 - Power input data are given for compressors only.

# Cooling Capacities - VLS HT

VLS HT models	LWT (°C)	Condenser entering air temperature (°C)													
		25		30		32		35		40		44		46	
		Cool. cap. (kW)	Input power (kW)	Cool. cap. (kW)	Input power (kW)	Cool. cap. (kW)	Input power (kW)	Cool. cap. (kW)	Input power (kW)	Cool. cap. (kW)	Input power (kW)	Cool. cap. (kW)	Input power (kW)	Cool. cap. (kW)	Input power (kW)
524	5	144.7	36.1	137.8	39.6	134.8	41.1	130.3	43.3	121.2	48.0	115.5	51.1	109.8	54.2
	6	149.0	36.5	141.8	40.1	138.8	41.5	134.2	43.8	124.8	48.5	118.9	51.6	113.1	54.7
	7	153.4	36.9	145.9	40.5	142.8	42.0	<b>138.1</b>	<b>44.2</b>	128.3	49.0	122.4	52.2	116.4	55.3
	8	157.2	37.4	149.6	41.0	146.5	42.4	141.6	44.7	131.6	49.5	125.5	52.6	119.3	55.8
	9	161.1	37.8	153.3	41.4	150.0	42.9	145.2	45.1	134.9	50.0	128.6	53.2	122.3	56.3
	10	165.0	38.3	157.0	41.9	153.7	43.4	148.6	45.7	138.0	50.5	131.6	53.7	125.2	56.9
	12	172.9	39.2	164.4	42.9	161.0	44.4	155.7	46.7	144.7	51.6	137.9	54.8	131.1	58.0
604	5	184.6	40.8	175.8	44.4	172.0	45.9	166.2	48.3	154.6	53.2	147.3	56.5	140.1	59.7
	6	163.6	39.8	155.7	43.6	152.4	45.2	147.3	47.7	136.9	52.9	130.6	56.3	124.2	59.7
	7	168.5	40.2	160.2	44.1	156.9	45.7	151.6	48.2	141.0	53.5	134.4	56.9	127.8	60.3
	8	173.4	40.7	164.9	44.6	161.4	46.3	<b>156.1</b>	<b>48.7</b>	145.1	54.0	138.3	57.5	131.6	60.9
	9	177.7	41.2	169.1	45.1	165.6	46.8	160.0	49.2	148.8	54.5	141.8	58.0	134.9	61.5
	10	182.1	41.7	173.3	45.7	169.6	47.3	164.1	49.7	152.5	55.1	145.4	58.6	138.2	62.0
	12	186.5	42.2	177.5	46.2	173.7	47.9	168.0	50.3	156.0	55.7	148.8	59.2	141.5	62.6
704	5	195.4	43.2	185.9	47.3	182.0	48.9	176.0	51.4	163.5	56.9	155.9	60.4	148.2	63.9
	6	208.7	44.9	198.7	48.9	194.5	50.6	187.9	53.2	174.7	58.6	166.5	62.2	158.3	65.8
	7	187.2	47.7	178.2	52.3	174.4	54.3	168.6	57.2	156.7	63.5	149.4	67.5	142.1	71.6
	8	192.7	48.2	183.3	52.9	179.5	54.8	173.5	57.8	161.4	64.1	153.8	68.2	146.2	72.3
	9	198.3	48.8	188.7	53.5	184.7	55.5	<b>178.6</b>	<b>58.4</b>	166.0	64.8	158.2	68.9	150.5	73.0
	10	203.3	49.4	193.5	54.1	189.4	56.1	183.1	59.1	170.2	65.4	162.3	69.6	154.3	73.7
	12	208.4	50.0	198.3	54.8	194.0	56.7	187.7	59.6	174.5	66.1	166.3	70.2	158.2	74.4
804	5	213.4	50.6	203.1	55.4	198.7	57.4	192.2	60.4	178.5	66.7	170.2	70.9	161.9	75.1
	6	223.5	51.9	212.7	56.7	208.2	58.7	201.3	61.7	187.1	68.2	178.3	72.4	169.5	76.7
	7	228.1	52.6	217.7	57.9	213.1	61.8	205.9	65.1	191.5	72.1	182.5	76.7	173.6	81.3
	8	234.4	53.8	223.0	60.4	218.2	62.6	211.2	65.8	196.3	72.9	187.1	77.4	177.9	82.0
	9	240.0	55.8	228.4	61.0	223.5	63.3	216.2	66.6	200.7	73.6	191.4	78.2	182.1	82.8
	10	251.5	57.2	239.2	62.5	234.2	64.7	226.5	68.0	210.4	75.2	200.6	79.9	190.7	84.6
	12	268.6	59.4	255.7	64.7	250.3	66.9	241.8	70.3	224.9	77.5	214.3	82.3	203.8	87.0
904	5	242.8	59.8	231.1	65.6	226.2	68.0	218.7	71.6	203.3	79.6	193.8	84.6	184.3	89.7
	6	250.1	60.4	237.8	66.3	232.9	68.7	225.1	72.5	209.3	80.4	199.5	85.5	189.7	90.6
	7	257.3	61.2	244.8	67.1	239.6	69.6	<b>231.7</b>	<b>73.2</b>	215.3	81.2	205.3	86.4	195.3	91.5
	8	263.8	61.9	251.0	67.8	245.8	70.3	237.5	74.0	220.8	82.0	210.5	87.2	200.2	92.4
	9	270.4	62.6	257.2	68.6	251.7	71.1	243.5	74.8	226.4	82.8	215.8	88.0	205.2	93.2
	10	276.8	63.5	263.4	69.4	257.8	71.9	249.3	75.6	231.5	83.7	220.8	88.9	210.1	94.2
	12	290.0	65.0	275.9	71.1	270.1	73.6	261.2	77.3	242.7	85.5	231.3	90.8	220.0	96.1
1004	5	309.7	67.5	294.9	73.5	288.7	76.1	278.9	80.0	259.4	88.1	247.2	93.5	235.0	98.9
	6	266.4	62.7	253.6	68.8	248.2	71.3	239.9	75.2	223.0	83.5	212.6	88.8	202.2	94.1
	7	274.3	63.4	260.9	69.6	255.5	72.1	246.9	76.0	229.7	84.3	218.9	89.7	208.2	95.1
	8	282.3	64.2	268.6	70.4	262.9	73.0	<b>254.2</b>	<b>76.8</b>	236.2	85.2	225.2	90.6	214.2	96.0
	9	289.4	64.9	275.4	71.2	269.6	73.8	260.6	77.7	242.3	86.0	231.0	91.5	219.6	96.9
	10	296.6	65.7	282.2	72.0	276.1	74.6	267.2	78.4	248.4	86.9	236.8	92.4	225.1	97.8
	12	303.7	66.6	289.0	72.8	282.8	75.5	273.6	79.4	254.0	87.8	242.2	93.3	230.5	98.8
1104	5	318.2	68.2	302.7	74.6	296.4	77.2	286.5	81.1	266.3	89.7	253.8	95.3	241.3	100.8
	6	339.8	70.8	323.5	77.1	316.7	79.8	305.9	83.9	284.6	92.5	271.2	98.1	257.8	103.8
	7	295.9	73.4	281.7	80.6	275.7	83.5	266.5	88.0	247.7	97.7	236.2	103.9	224.6	110.2
	8	304.8	74.2	289.9	81.5	283.9	84.4	274.3	89.0	255.1	98.7	243.2	105.0	231.2	111.3
	9	313.6	75.1	298.4	82.4	292.0	85.4	<b>282.4</b>	<b>89.9</b>	262.4	99.8	250.2	106.1	238.0	112.4
	10	321.5	76.0	306.0	83.3	299.5	86.3	289.5	90.9	269.2	100.7	256.6	107.1	244.0	113.4
	12	329.5	76.9	313.5	84.3	306.7	87.3	296.8	91.8	275.9	101.7	263.0	108.1	250.1	114.5
1204	5	337.4	77.9	321.1	85.2	314.2	88.3	303.9	92.9	282.2	102.7	269.1	109.2	256.0	115.6
	6	353.5	79.8	336.3	87.3	329.3	90.3	318.3	94.9	295.8	105.0	282.0	111.5	268.1	118.0
	7	377.5	82.9	359.4	90.3	351.8	93.4	339.9	98.2	316.1	108.3	301.3	114.9	286.4	121.5
	8	328.3	84.2	312.5	92.4	305.9	95.8	295.7	100.9	274.9	112.1	262.0	119.2	249.2	126.4
	9	338.1	85.1	321.6	93.4	314.9	96.8	304.4	102.1	283.1	113.2	269.8	120.5	256.5	127.7
	10	347.9	86.2	331.0	94.5	324.0	98.0	<b>313.3</b>	<b>103.1</b>	291.2	114.4	277.6	121.6	264.0	128.9
	12	356.7	87.2	339.4	95.5	332.3	99.0	321.1	104.3	298.6	115.5	284.7	122.8	270.7	130.1
1204	5	365.6	88.2	347.8	96.7	340.3	100.2	329.3	105.3	306.1	116.7	291.8	124.0	277.5	131.3
	6	374.3	89.4	356.2	97.7	348.6	101.3	337.1	106.6	313.1	117.8	298.6	125.2	284.0	132.6
	7	392.1	91.5	373.1	100.1	365.3	103.6	353.2	108.9	328.2	120.4	312.8	127.9	297.4	135.4
	8	418.8	95.1	398.7	103.6	390.3	107.2	377.1	112.6	350.7	124.1	334.2	131.7	317.8	139.3

Notes : - LWT : Leaving water temperature.  
 - Power input data are given for compressors only.

# Cooling Capacities - VLH STD/HSE/SIF-BLN Version

VLH STD/HSE/SIF models	LWT (°C)	Condenser entering air temperature (°C)													
		25		30		32		35		40		44		46	
		Cool. cap. (kW)	Input power (kW)	Cool. cap. (kW)	Input power (kW)	Cool. cap. (kW)	Input power (kW)	Cool. cap. (kW)	Input power (kW)	Cool. cap. (kW)	Input power (kW)	Cool. cap. (kW)	Input power (kW)	Cool. cap. (kW)	Input power (kW)
524 BLN	5	140.6	36.7	133.9	40.3	131.0	41.8	126.6	44.0	117.7	48.9	112.2	52.0	106.7	55.2
	6	144.8	37.1	137.8	40.8	134.9	42.3	130.4	44.5	121.3	49.4	115.6	52.6	109.9	55.7
	7	149.0	37.6	141.8	41.2	138.8	42.8	<b>134.2</b>	<b>45.0</b>	124.7	49.9	118.9	53.1	113.1	56.3
	8	152.8	38.1	145.4	41.7	142.3	43.2	137.6	45.5	127.9	50.4	121.9	53.6	116.0	56.8
	9	156.6	38.5	149.0	42.2	145.8	43.7	141.1	46.0	131.1	50.9	125.0	54.1	118.9	57.3
	10	160.3	39.0	152.6	42.7	149.3	44.2	144.4	46.5	134.1	51.4	127.9	54.7	121.7	57.9
	12	168.0	40.0	159.8	43.7	156.5	45.2	151.3	47.5	140.6	52.6	134.0	55.8	127.4	59.1
15	179.4	41.5	170.8	45.2	167.2	46.8	161.5	49.2	150.2	54.2	143.2	57.5	136.1	60.8	
604 BLN	5	157.3	41.0	149.7	45.0	146.5	46.6	141.7	49.1	131.7	54.6	125.5	58.0	119.4	61.5
	6	162.0	41.4	154.1	45.5	150.9	47.1	145.8	49.7	135.6	55.1	129.3	58.6	122.9	62.2
	7	166.7	41.9	158.6	46.0	155.2	47.7	<b>150.1</b>	<b>50.2</b>	139.5	55.7	133.0	59.2	126.5	62.8
	8	170.9	42.5	162.6	46.5	159.2	48.2	153.9	50.8	143.1	56.2	136.4	59.8	129.7	63.3
	9	175.1	43.0	166.6	47.1	163.0	48.8	157.8	51.3	146.7	56.8	139.8	60.4	132.9	63.9
	10	179.3	43.5	170.7	47.6	167.0	49.3	161.5	51.9	150.0	57.4	143.0	61.0	136.1	64.6
	12	187.9	44.6	178.7	48.7	175.0	50.4	169.2	53.0	157.2	58.6	149.9	62.3	142.5	65.9
15	200.7	46.3	191.0	50.4	187.0	52.2	180.7	54.8	168.0	60.4	160.1	64.1	152.2	67.8	
704 BLN	5	182.3	48.5	173.6	53.2	169.9	55.2	164.2	58.1	152.6	64.6	145.5	68.7	138.4	72.8
	6	187.8	49.0	178.6	53.8	174.9	55.8	169.0	58.8	157.2	65.2	149.8	69.4	142.5	73.6
	7	193.2	49.6	183.9	54.4	179.9	56.4	<b>174.0</b>	<b>59.4</b>	161.7	65.9	154.2	70.1	146.6	74.3
	8	198.1	50.2	188.5	55.0	184.6	57.0	178.4	60.1	165.8	66.5	158.1	70.7	150.3	75.0
	9	203.0	50.8	193.2	55.7	189.0	57.7	182.9	60.7	170.0	67.2	162.1	71.4	154.1	75.6
	10	207.9	51.5	197.8	56.3	193.6	58.4	187.2	61.4	173.9	67.9	165.8	72.1	157.8	76.4
	12	217.8	52.7	207.2	57.7	202.9	59.7	196.1	62.7	182.3	69.4	173.7	73.7	165.2	78.0
15	232.6	54.8	221.5	59.7	216.8	61.7	209.4	64.9	194.8	71.5	185.6	75.9	176.5	80.3	
804 BLN	5	207.1	53.5	197.1	58.7	192.9	60.8	186.5	64.1	173.4	71.2	165.3	75.7	157.2	80.3
	6	213.3	54.1	202.8	59.4	198.6	61.5	192.0	64.8	178.5	71.9	170.2	76.5	161.8	81.1
	7	219.4	54.7	208.8	60.0	204.3	62.2	<b>197.6</b>	<b>65.5</b>	183.6	72.7	175.1	77.3	166.5	81.9
	8	224.9	55.4	214.1	60.7	209.6	62.9	202.5	66.2	188.3	73.4	179.5	78.0	170.7	82.6
	9	230.6	56.1	219.4	61.4	214.6	63.6	207.7	66.9	193.1	74.1	184.0	78.8	175.0	83.4
	10	236.1	56.8	224.7	62.1	219.9	64.4	212.6	67.7	197.5	74.9	188.3	79.6	179.2	84.3
	12	247.3	58.2	235.3	63.6	230.4	65.8	222.7	69.2	207.0	76.5	197.3	81.2	187.6	86.0
15	264.2	60.4	251.5	65.8	246.2	68.1	237.8	71.5	221.2	78.9	210.8	83.7	200.4	88.5	
904 BLN	5	237.6	60.6	226.1	66.5	221.3	68.9	213.9	72.6	198.9	80.6	189.6	85.8	180.3	90.9
	6	244.7	61.3	232.7	67.3	227.9	69.7	220.2	73.4	204.8	81.5	195.2	86.7	185.6	91.9
	7	251.8	62.0	239.5	68.0	234.4	70.5	<b>226.7</b>	<b>74.2</b>	210.7	82.3	200.9	87.5	191.1	92.8
	8	258.1	62.7	245.6	68.8	240.5	71.3	232.4	75.0	216.1	83.1	206.0	88.4	195.9	93.6
	9	264.5	63.5	251.7	69.6	246.2	72.1	238.3	75.8	221.5	84.0	211.1	89.2	200.8	94.5
	10	270.8	64.3	257.7	70.3	252.3	72.9	244.0	76.7	226.5	84.8	216.0	90.1	205.5	95.4
	12	283.7	65.9	269.9	72.1	264.3	74.6	255.5	78.3	237.5	86.6	226.3	92.0	215.2	97.4
15	303.1	68.4	288.5	74.5	282.4	77.1	272.8	81.0	253.8	89.3	241.9	94.8	229.9	100.3	
1004 BLN	5	258.6	64.0	246.2	70.3	240.9	72.8	232.9	76.7	216.5	85.2	206.4	90.6	196.3	96.1
	6	266.4	64.7	253.3	71.1	248.1	73.6	239.8	77.6	223.0	86.1	212.5	91.6	202.1	97.1
	7	274.1	65.5	260.8	71.9	255.2	74.5	<b>246.8</b>	<b>78.4</b>	229.4	87.0	218.7	92.5	208.0	98.0
	8	281.0	66.3	267.4	72.6	261.8	75.3	253.0	79.3	235.2	87.8	224.2	93.4	213.3	98.9
	9	288.0	67.1	274.0	73.5	268.1	76.2	259.4	80.1	241.1	88.7	229.9	94.3	218.6	99.8
	10	294.8	68.0	280.6	74.3	274.6	77.0	265.6	81.0	246.6	89.6	235.2	95.2	223.8	100.9
	12	308.9	69.6	293.9	76.1	287.8	78.8	278.2	82.8	258.5	91.6	246.4	97.2	234.3	102.9
15	329.9	72.3	314.1	78.7	307.5	81.5	297.0	85.6	276.3	94.4	263.3	100.2	250.3	106.0	
1104 BLN	5	287.0	74.5	273.2	81.8	267.4	84.8	258.5	89.4	240.3	99.2	229.1	105.6		
	6	295.6	75.4	281.1	82.8	275.3	85.7	266.1	90.4	247.5	100.3	235.9	106.7		
	7	304.2	76.3	289.4	83.7	283.3	86.8	<b>273.9</b>	<b>91.3</b>	254.5	101.3	242.7	107.7		
	8	311.8	77.2	296.8	84.6	290.5	87.7	280.8	92.3	261.1	102.3	248.9	108.7		
	9	319.6	78.1	304.1	85.6	297.5	88.7	287.9	93.2	267.6	103.3	255.1	109.8		
	10	327.2	79.1	311.4	86.5	304.8	89.7	294.7	94.4	273.7	104.3	261.0	110.9		
	12	342.8	81.1	326.1	88.7	319.4	91.7	308.7	96.4	286.9	106.6	273.5	113.2		
15	366.2	84.2	348.6	91.7	341.2	94.9	329.7	99.7	306.6	109.9	292.2	116.7			
1204 BLN	5	314.9	86.1	299.8	94.6	293.4	98.0	283.6	103.3	263.6	114.7	251.3	122.0		
	6	324.3	87.1	308.5	95.6	302.1	99.1	291.9	104.4	271.5	115.9	258.8	123.3		
	7	333.7	88.2	317.5	96.7	310.8	100.2	<b>300.5</b>	<b>105.5</b>	279.3	117.1	266.3	124.5		
	8	342.1	89.2	325.6	97.8	318.7	101.3	308.0	106.7	286.4	118.2	273.0	125.6		
	9	350.6	90.3	333.6	98.9	326.4	102.5	315.9	107.7	293.6	119.4	279.9	126.9		
	10	359.0	91.4	341.6	100.0	334.4	103.7	323.4	109.0	300.3	120.6	286.4	128.1		
	12	376.1	93.7	357.8	102.4	350.4	106.0	338.7	111.4	314.8	123.2	300.0	130.9		
15	401.7	97.3	382.4	106.0	374.4	109.6	361.7	115.2	336.4	127.0	320.6	134.8			

Notes : - LWT : Leaving water temperature.  
 - Power input data are given for compressors only.

# Heating Capacities - VLH STD/HSE/SIF-BLN Version

VLH STD/HSE/ SIF models	LWT (°C)	Ambient coil entering air temperature (°C)													
		-5		-3		0		5		7		10		15	
		Heat. cap. (kW)	Input power (kW)	Heat. cap. (kW)	Input power (kW)	Heat. cap. (kW)	Input power (kW)	Heat. cap. (kW)	Input power (kW)	Heat. cap. (kW)	Input power (kW)	Heat. cap. (kW)	Input power (kW)	Heat. cap. (kW)	Input power (kW)
524 BLN	30	114.4	31.1	120.4	31.2	130.2	31.2	147.2	31.7	154.7	31.9	166.7	32.2	188.8	32.8
	35	112.9	36.5	120.0	34.9	129.4	35.0	145.7	35.4	152.9	35.6	164.4	35.9	185.5	36.5
	40	111.6	40.9	118.8	39.1	128.8	39.2	144.4	39.6	151.2	39.8	162.2	40.2	182.2	40.8
	45	110.4	46.0	117.4	43.9	127.3	44.1	143.2	44.5	<b>149.6</b>	<b>44.7</b>	160.1	45.0	178.9	45.6
	50					126.0	49.8	142.4	50.1	148.4	50.3	158.1	50.6	175.8	51.1
604 BLN	30	129.3	35.7	136.0	35.8	147.0	35.9	166.3	36.4	174.7	36.6	188.3	37.0	213.3	37.6
	35	127.6	41.9	135.5	40.0	146.2	40.1	164.6	40.6	172.7	40.9	185.7	41.2	209.6	41.9
	40	126.1	47.0	134.2	44.8	145.5	45.0	163.1	45.5	170.9	45.7	183.2	46.1	205.8	46.8
	45	124.7	52.8	132.7	50.4	143.8	50.6	161.7	51.0	<b>169.0</b>	<b>51.3</b>	180.8	51.7	202.1	52.4
	50					142.3	57.2	160.9	57.5	167.6	57.7	178.6	58.0	198.6	58.7
704 BLN	30	152.4	42.1	160.4	42.2	173.3	42.4	196.0	43.0	206.0	43.3	221.9	43.7	251.4	44.4
	35	150.4	49.5	159.8	47.3	172.3	47.4	194.0	48.0	203.6	48.3	218.9	48.7	247.0	49.5
	40	148.6	55.5	158.2	53.0	171.5	53.1	192.2	53.8	201.4	54.0	215.9	54.5	242.6	55.3
	45	147.0	62.4	156.4	59.5	169.5	59.8	190.6	60.3	<b>199.2</b>	<b>60.6</b>	213.1	61.0	238.2	61.9
	50					167.7	67.6	189.6	67.9	197.6	68.2	210.6	68.5	234.1	69.3
804 BLN	30	169.8	44.1	178.6	44.3	193.1	44.4	218.3	45.0	229.4	45.3	247.2	45.8	280.0	46.5
	35	167.5	51.9	178.0	49.5	191.9	49.7	216.1	50.3	226.8	50.6	243.9	51.1	275.2	51.9
	40	165.5	58.2	176.2	55.5	191.1	55.7	214.1	56.3	224.3	56.6	240.5	57.1	270.3	57.9
	45	163.8	65.4	174.2	62.4	188.8	62.6	212.4	63.2	<b>221.9</b>	<b>63.5</b>	237.4	63.9	265.4	64.8
	50					186.8	70.8	211.2	71.2	220.1	71.4	234.5	71.8	260.7	72.6
904 BLN	30	194.4	49.6	204.6	49.8	221.1	49.9	250.0	50.6	262.7	51.0	283.1	51.5	320.7	52.3
	35	191.8	58.3	203.8	55.7	219.8	55.8	247.5	56.5	259.7	56.9	279.3	57.4	315.1	58.3
	40	189.6	65.4	201.8	62.4	218.8	62.6	245.2	63.3	256.9	63.6	275.4	64.2	309.5	65.1
	45	187.5	73.5	199.5	70.1	216.2	70.4	243.2	71.0	<b>254.1</b>	<b>71.4</b>	271.9	71.9	303.9	72.9
	50					214.0	79.6	241.9	80.0	252.1	80.3	268.6	80.8	298.6	81.7
1004 BLN	30	206.6	55.1	217.4	55.3	234.9	55.4	265.7	56.2	279.2	56.6	300.8	57.2	340.7	58.1
	35	203.9	64.8	216.5	61.9	233.6	62.0	263.0	62.8	275.9	63.2	296.7	63.8	334.8	64.8
	40	201.4	72.6	214.4	69.3	232.5	69.5	260.6	70.3	273.0	70.7	292.7	71.3	328.9	72.3
	45	199.3	81.7	212.0	77.9	229.8	78.2	258.4	78.9	<b>270.0</b>	<b>79.3</b>	288.9	79.9	322.9	81.0
	50					227.3	88.4	257.0	88.9	267.8	89.2	285.4	89.7	317.3	90.7
1104 BLN	30	230.1	63.5	242.1	63.6	261.7	63.8	296.0	64.7	311.0	65.2	335.1	65.8	379.6	66.9
	35	227.1	74.6	241.2	71.2	260.2	71.4	293.0	72.3	307.4	72.8	330.6	73.4	373.0	74.6
	40	224.4	83.6	238.8	79.8	259.0	80.1	290.3	81.0	304.1	81.3	326.1	82.1	366.4	83.3
	45	222.0	94.0	236.1	89.7	256.0	90.0	287.9	90.8	<b>300.8</b>	<b>91.3</b>	321.9	91.9	359.8	93.2
	50					253.3	101.8	286.4	102.3	298.4	102.7	317.9	103.3	353.4	104.4
1204 BLN	30	256.9	71.9	270.3	72.1	292.1	72.3	330.4	73.3	347.2	73.8	374.1	74.6	423.8	75.8
	35	253.5	84.5	269.3	80.7	290.5	80.9	327.1	81.9	343.2	82.4	369.0	83.1	416.4	84.5
	40	250.5	94.7	266.6	90.4	289.1	90.7	324.0	91.7	339.5	92.1	364.0	93.0	409.0	94.3
	45	247.8	106.5	263.6	101.5	285.8	102.0	321.4	102.9	<b>335.8</b>	<b>103.4</b>	359.3	104.1	401.6	105.6
	50					282.7	115.3	319.7	115.9	333.1	116.3	354.9	116.9	394.6	118.3

Notes : - LWT : Leaving water temperature.  
 - Power input data are given for compressors only.  
 - Heating capacities refer to instant capacity values.

# Cooling Capacities - VLH STD/HSE-LN Version

VLH STD/HSE models	LWT (°C)	Condenser entering air temperature (°C)											
		25		30		32		35		40		44	
		Cool. cap. (kW)	Input power (kW)	Cool. cap. (kW)	Input power (kW)	Cool. cap. (kW)	Input power (kW)	Cool. cap. (kW)	Input power (kW)	Cool. cap. (kW)	Input power (kW)	Cool. cap. (kW)	Input power (kW)
524 LN	5	136.2	38.6	129.7	42.4	126.9	43.9	122.7	46.3	114.0	51.4	108.7	54.7
	6	140.3	39.0	133.4	42.9	130.7	44.4	126.3	46.8	117.5	51.9	112.0	55.3
	7	144.4	39.5	137.4	43.4	134.4	44.9	<b>130.0</b>	<b>47.3</b>	120.8	52.5	115.2	55.8
	8	148.0	40.0	140.8	43.8	137.9	45.4	133.3	47.8	123.9	53.0	118.1	56.3
	9	151.7	40.5	144.3	44.4	141.2	46.0	136.6	48.3	127.0	53.5	121.1	56.9
	10	155.3	41.0	147.8	44.8	144.7	46.5	139.9	48.9	129.9	54.1	123.9	57.5
	12	162.7	42.0	154.8	45.9	151.6	47.5	146.5	49.9	136.2	55.2	129.8	58.7
15	173.8	43.6	165.5	47.5	162.0	49.2	156.5	51.7	145.5	57.0	138.7	60.4	
604 LN	5	152.9	42.9	145.5	47.1	142.4	48.8	137.7	51.4	128.0	57.1	122.0	60.7
	6	157.5	43.3	149.8	47.6	146.7	49.3	141.7	52.0	131.8	57.7	125.6	61.3
	7	162.0	43.9	154.2	48.1	150.9	49.9	<b>145.9</b>	<b>52.5</b>	135.6	58.3	129.3	61.9
	8	166.1	44.4	158.1	48.6	154.8	50.4	149.6	53.1	139.1	58.8	132.6	62.5
	9	170.2	44.9	162.0	49.2	158.5	51.0	153.4	53.6	142.6	59.4	135.9	63.1
	10	174.3	45.5	165.9	49.8	162.3	51.6	157.0	54.3	145.8	60.0	139.0	63.8
	12	182.6	46.6	173.7	51.0	170.1	52.8	164.5	55.4	152.8	61.3	145.7	65.1
15	195.0	48.4	185.7	52.7	181.8	54.6	175.6	57.3	163.3	63.2	155.7	67.1	
704 LN	5	177.3	50.7	168.8	55.7	165.2	57.7	159.7	60.8	148.4	67.5	141.5	71.8
	6	182.6	51.3	173.7	56.3	170.1	58.3	164.4	61.5	152.9	68.2	145.7	72.6
	7	187.9	51.9	178.8	56.9	175.0	59.0	<b>169.2</b>	<b>62.1</b>	157.2	68.9	149.9	73.3
	8	192.6	52.5	183.3	57.5	179.5	59.6	173.4	62.8	161.3	69.6	153.7	74.0
	9	197.4	53.1	187.8	58.2	183.8	60.3	177.8	63.4	165.3	70.3	157.6	74.7
	10	202.1	53.8	192.4	58.9	188.3	61.0	182.1	64.2	169.1	71.0	161.2	75.4
	12	211.8	55.1	201.5	60.3	197.3	62.4	190.7	65.6	177.2	72.5	168.9	77.0
15	226.2	57.3	215.3	62.4	210.8	64.5	203.6	67.8	189.4	74.8	180.5	79.3	
804 LN	5	200.8	56.2	191.1	61.7	187.1	63.9	180.8	67.3	168.1	74.8	160.2	79.5
	6	206.8	56.8	196.7	62.4	192.6	64.6	186.1	68.1	173.1	75.6	165.0	80.4
	7	212.8	57.5	202.4	63.1	198.1	65.4	<b>191.6</b>	<b>68.8</b>	178.1	76.3	169.8	81.2
	8	218.1	58.2	207.6	63.8	203.2	66.1	196.4	69.6	182.6	77.1	174.1	81.9
	9	223.6	58.9	212.7	64.5	208.1	66.8	201.4	70.3	187.2	77.8	178.4	82.7
	10	228.9	59.6	217.8	65.2	213.2	67.6	206.2	71.1	191.5	78.6	182.6	83.6
	12	239.8	61.1	228.1	66.8	223.4	69.1	216.0	72.6	200.7	80.3	191.3	85.3
15	256.1	63.4	243.9	69.1	238.7	71.5	230.6	75.1	214.5	82.8	204.4	87.9	
904 LN	5	231.8	63.9	220.7	70.2	216.0	72.7	208.8	76.6	194.1	85.1	185.0	90.5
	6	238.7	64.6	227.1	71.0	222.4	73.5	214.9	77.5	199.9	86.0	190.5	91.5
	7	245.7	65.4	233.7	71.8	228.8	74.4	<b>221.2</b>	<b>78.3</b>	205.6	86.9	196.0	92.4
	8	251.8	66.2	239.7	72.6	234.6	75.2	226.7	79.2	210.8	87.7	201.0	93.2
	9	258.1	67.0	245.6	73.4	240.3	76.1	232.5	80.0	216.1	88.6	206.0	94.2
	10	264.3	67.9	251.5	74.2	246.1	76.9	238.0	80.9	221.0	89.5	210.8	95.1
	12	276.9	69.5	263.4	76.0	257.9	78.7	249.3	82.7	231.7	91.4	220.8	97.1
15	295.7	72.2	281.5	78.6	275.6	81.4	266.2	85.5	247.6	94.3	236.0	100.0	
1004 LN	5	249.2	67.7	237.2	74.3	232.2	77.0	224.4	81.1	208.6	90.1	198.9	95.8
	6	256.6	68.4	244.1	75.1	239.0	77.9	231.0	82.1	214.9	91.0	204.8	96.9
	7	264.1	69.3	251.3	76.0	245.9	78.8	<b>237.8</b>	<b>82.9</b>	221.0	92.0	210.7	97.8
	8	270.7	70.1	257.6	76.8	252.2	79.6	243.8	83.8	226.6	92.9	216.1	98.7
	9	277.5	70.9	264.0	77.7	258.3	80.5	249.9	84.7	232.3	93.8	221.5	99.7
	10	284.1	71.9	270.4	78.6	264.6	81.5	255.9	85.7	237.6	94.7	226.6	100.7
	12	297.6	73.6	283.2	80.5	277.3	83.3	268.1	87.5	249.1	96.8	237.4	102.8
15	317.9	76.4	302.7	83.3	296.3	86.2	286.2	90.6	266.2	99.8	253.7	105.9	
1104 LN	5	274.6	79.8	261.5	87.6	255.9	90.8	247.4	95.6	229.9	106.2		
	6	282.9	80.7	269.0	88.6	263.5	91.8	254.6	96.7	236.8	107.3		
	7	291.1	81.6	276.9	89.5	271.1	92.8	<b>262.1</b>	<b>97.7</b>	243.6	108.4		
	8	298.4	82.6	284.0	90.5	278.0	93.8	268.7	98.8	249.8	109.4		
	9	305.8	83.6	291.0	91.6	284.7	94.9	275.5	99.8	256.1	110.5		
	10	313.1	84.7	298.0	92.6	291.6	96.0	282.1	101.0	261.9	111.7		
	12	328.1	86.8	312.1	94.9	305.6	98.2	295.4	103.1	274.6	114.1		
15	350.4	90.1	333.6	98.1	326.5	101.5	315.5	106.7	293.4	117.6			
1204 LN	5	299.9	92.9	285.5	102.0	279.4	105.7	270.1	111.4	251.1	123.7		
	6	308.9	93.9	293.8	103.1	287.7	106.9	278.0	112.6	258.6	125.0		
	7	317.8	95.1	302.4	104.3	296.0	108.1	<b>286.2</b>	<b>113.8</b>	266.0	126.3		
	8	325.8	96.2	310.1	105.4	303.6	109.3	293.4	115.1	272.8	127.5		
	9	333.9	97.4	317.7	106.7	310.9	110.6	300.8	116.2	279.6	128.8		
	10	341.9	98.6	325.4	107.9	318.5	111.8	308.0	117.6	286.0	130.1		
	12	358.2	101.0	340.8	110.5	333.7	114.4	322.6	120.1	299.8	132.9		
15	382.6	104.9	364.2	114.3	356.5	118.3	344.5	124.3	320.4	137.0			

Notes : - LWT : Leaving water temperature.  
 - Power input data are given for compressors only.

# Heating Capacities - VLH STD/HSE-LN Version

VLH STD/HSE models	LWT (°C)	Ambient coil entering air temperature (°C)													
		-5		-3		0		5		7		10		15	
		Heat. cap. (kW)	Input power (kW)	Heat. cap. (kW)	Input power (kW)	Heat. cap. (kW)	Input power (kW)	Heat. cap. (kW)	Input power (kW)	Heat. cap. (kW)	Input power (kW)	Heat. cap. (kW)	Input power (kW)	Heat. cap. (kW)	Input power (kW)
524 LN	30	111.4	31.0	117.2	31.1	126.7	31.2	143.3	31.6	150.6	31.8	162.2	32.2	183.7	32.7
	35	109.9	36.4	116.8	34.8	125.9	34.9	141.8	35.3	148.8	35.5	160.0	35.9	180.5	36.4
	40	108.6	40.9	115.6	39.0	125.4	39.1	140.5	39.6	147.2	39.7	157.8	40.1	177.3	40.7
	45	107.5	45.9	114.3	43.8	123.9	44.0	139.3	44.4	<b>145.6</b>	<b>44.6</b>	155.8	44.9	174.1	45.5
	50					122.6	49.7	138.6	50.0	144.4	50.2	153.9	50.4	171.1	51.0
604 LN	30	125.8	35.7	132.4	35.8	143.1	35.9	161.9	36.4	170.1	36.7	183.3	37.1	207.6	37.7
	35	124.2	42.0	131.9	40.1	142.3	40.2	160.2	40.7	168.1	41.0	180.8	41.3	204.0	42.0
	40	122.7	47.1	130.6	44.9	141.6	45.1	158.7	45.6	166.3	45.8	178.3	46.2	200.4	46.9
	45	121.4	52.9	129.1	50.5	140.0	50.7	157.4	51.1	<b>164.5</b>	<b>51.4</b>	176.0	51.8	196.7	52.5
	50					138.5	57.3	156.6	57.6	163.2	57.8	173.9	58.1	193.3	58.8
704 LN	30	148.6	42.1	156.3	42.2	169.0	42.4	191.1	43.0	200.8	43.3	216.3	43.7	245.1	44.4
	35	146.6	49.5	155.7	47.3	168.0	47.4	189.2	48.0	198.5	48.3	213.4	48.7	240.8	49.5
	40	144.9	55.5	154.2	53.0	167.2	53.1	187.4	53.8	196.3	54.0	210.5	54.5	236.5	55.3
	45	143.3	62.4	152.4	59.5	165.3	59.8	185.8	60.3	<b>194.2</b>	<b>60.6</b>	207.8	61.0	232.3	61.9
	50					163.5	67.6	184.9	67.9	192.6	68.2	205.3	68.5	228.2	69.3
804 LN	30	164.9	44.0	173.6	44.1	187.6	44.2	212.2	44.9	222.9	45.2	240.2	45.6	272.1	46.4
	35	162.8	51.7	172.9	49.4	186.5	49.5	210.0	50.1	220.3	50.5	236.9	50.9	267.3	51.7
	40	160.8	58.0	171.2	55.3	185.6	55.5	208.1	56.1	218.0	56.4	233.7	56.9	262.6	57.7
	45	159.1	65.2	169.2	62.2	183.5	62.4	206.3	63.0	<b>215.6</b>	<b>63.3</b>	230.7	63.7	257.9	64.6
	50					181.5	70.6	205.3	71.0	213.9	71.2	227.9	71.6	253.3	72.4
904 LN	30	188.6	49.5	198.4	49.6	214.5	49.8	242.6	50.5	254.9	50.8	274.6	51.3	311.1	52.2
	35	186.1	58.2	197.7	55.5	213.2	55.7	240.1	56.4	251.9	56.7	270.9	57.2	305.7	58.2
	40	183.9	65.2	195.7	62.2	212.2	62.4	237.9	63.2	249.2	63.4	267.2	64.0	300.2	64.9
	45	181.9	73.3	193.5	69.9	209.8	70.2	235.9	70.8	<b>246.5</b>	<b>71.2</b>	263.8	71.7	294.8	72.7
	50					207.6	79.4	234.7	79.8	244.5	80.1	260.6	80.5	289.6	81.5
1004 LN	30	199.7	55.0	210.2	55.1	227.2	55.3	256.9	56.1	270.0	56.5	290.9	57.0	329.5	58.0
	35	197.1	64.6	209.4	61.7	225.9	61.9	254.3	62.6	266.8	63.0	286.9	63.6	323.8	64.6
	40	194.8	72.5	207.3	69.1	224.8	69.4	252.0	70.2	264.0	70.5	283.0	71.1	318.0	72.1
	45	192.7	81.5	205.0	77.7	222.2	78.0	249.9	78.7	<b>261.1</b>	<b>79.1</b>	279.4	79.7	312.3	80.8
	50					219.8	88.2	248.6	88.7	259.0	89.0	276.0	89.5	306.8	90.5
1104 LN	30	220.0	63.4	231.5	63.6	250.2	63.7	283.0	64.7	297.4	65.1	320.4	65.8	363.0	66.8
	35	217.1	74.5	230.7	71.1	248.8	71.3	280.1	72.2	293.9	72.7	316.1	73.3	356.6	74.5
	40	214.5	83.5	228.4	79.7	247.6	80.0	277.5	80.9	290.8	81.3	311.8	82.0	350.3	83.2
	45	212.2	93.9	225.8	89.6	244.7	89.9	275.2	90.7	<b>287.6</b>	<b>91.2</b>	307.7	91.8	344.0	93.1
	50					242.2	101.7	273.8	102.2	285.3	102.6	304.0	103.1	337.9	104.3
1204 LN	30	245.3	71.8	258.2	72.0	279.0	72.2	315.6	73.2	331.6	73.8	357.3	74.5	404.7	75.7
	35	242.1	84.4	257.2	80.6	277.4	80.8	312.4	81.8	327.8	82.3	352.4	83.1	397.7	84.4
	40	239.2	94.6	254.6	90.3	276.1	90.6	309.5	91.6	324.2	92.0	347.6	92.9	390.6	94.2
	45	236.7	106.4	251.7	101.4	272.9	101.9	306.9	102.8	<b>320.7</b>	<b>103.3</b>	343.1	104.0	383.6	105.5
	50					270.0	115.2	305.3	115.8	318.1	116.2	339.0	116.8	376.8	118.2

- Notes :
- LWT : Leaving water temperature.
  - Power input data are given for compressors only.
  - Heating capacities refer to instant capacity values.



# Cooling Capacities - VLH STD/HSE-ELN Version

VLH STD/HSE models	LWT (°C)	Condenser entering air temperature (°C)									
		25		30		32		35		40	
		Cool. cap. (kW)	Input power (kW)	Cool. cap. (kW)	Input power (kW)	Cool. cap. (kW)	Input power (kW)	Cool. cap. (kW)	Input power (kW)	Cool. cap. (kW)	Input power (kW)
524 ELN	5	131.6	40.6	125.3	44.5	122.6	46.2	118.5	48.6	110.2	54.0
	6	135.5	41.0	128.9	45.0	126.3	46.7	122.0	49.2	113.5	54.6
	7	139.5	41.5	132.7	45.6	129.9	47.2	<b>125.6</b>	<b>49.7</b>	116.7	55.1
	8	143.0	42.0	136.1	46.1	133.2	47.7	128.7	50.3	119.7	55.7
	9	146.6	42.5	139.4	46.6	136.4	48.3	132.0	50.8	122.7	56.2
	10	150.0	43.1	142.8	47.1	139.8	48.8	135.2	51.4	125.5	56.8
	12	157.2	44.1	149.6	48.3	146.4	49.9	141.6	52.5	131.6	58.0
15	167.9	45.8	159.9	49.9	156.5	51.7	151.2	54.3	140.6	59.8	
604 ELN	5	149.0	44.6	141.9	48.9	138.8	50.7	134.2	53.4	124.7	59.3
	6	153.5	45.1	146.0	49.5	142.9	51.3	138.1	54.0	128.5	60.0
	7	157.9	45.6	150.3	50.0	147.1	51.9	<b>142.2</b>	<b>54.6</b>	132.1	60.6
	8	161.9	46.2	154.1	50.6	150.8	52.4	145.8	55.2	135.5	61.2
	9	165.9	46.7	157.9	51.2	154.5	53.0	149.5	55.8	138.9	61.8
	10	169.9	47.3	161.7	51.8	158.2	53.7	153.0	56.4	142.1	62.4
	12	178.0	48.5	169.3	53.0	165.8	54.9	160.3	57.6	149.0	63.8
15	190.1	50.4	181.0	54.8	177.2	56.7	171.1	59.6	159.2	65.7	
704 ELN	5	172.5	53.0	164.2	58.2	160.7	60.3	155.3	63.5	144.4	70.5
	6	177.6	53.6	169.0	58.8	165.5	60.9	159.9	64.2	148.7	71.3
	7	182.8	54.2	173.9	59.5	170.2	61.7	<b>164.6</b>	<b>64.9</b>	153.0	72.0
	8	187.4	54.9	178.3	60.1	174.6	62.3	168.7	65.6	156.9	72.7
	9	192.1	55.5	182.7	60.9	178.8	63.0	173.0	66.3	160.8	73.4
	10	196.6	56.3	187.1	61.5	183.2	63.8	177.1	67.1	164.5	74.2
	12	206.0	57.6	196.0	63.0	191.9	65.2	185.5	68.5	172.4	75.8
15	220.0	59.9	209.5	65.2	205.1	67.4	198.1	70.9	184.3	78.1	
804 ELN	5	194.6	59.0	185.2	64.8	181.3	67.2	175.3	70.8	162.9	78.6
	6	200.4	59.7	190.6	65.5	186.7	67.9	180.4	71.6	167.8	79.4
	7	206.2	60.4	196.2	66.3	192.0	68.7	<b>185.7</b>	<b>72.3</b>	172.6	80.2
	8	211.4	61.1	201.2	67.0	197.0	69.4	190.3	73.1	177.0	81.0
	9	216.7	61.9	206.1	67.8	201.7	70.2	195.2	73.8	181.4	81.8
	10	221.8	62.7	211.1	68.5	206.6	71.0	199.8	74.7	185.6	82.6
	12	232.4	64.2	221.1	70.2	216.5	72.7	209.3	76.3	194.5	84.4
15	248.2	66.7	236.3	72.6	231.3	75.1	223.5	79.0	207.9	87.1	
904 ELN	5	225.1	66.6	214.3	73.1	209.7	75.8	202.7	79.9	188.4	88.7
	6	231.8	67.4	220.5	74.0	215.9	76.6	208.7	80.8	194.1	89.6
	7	238.5	68.2	227.0	74.8	222.1	77.5	<b>214.8</b>	<b>81.6</b>	199.6	90.5
	8	244.5	69.0	232.7	75.6	227.8	78.4	220.2	82.5	204.7	91.4
	9	250.6	69.8	238.4	76.5	233.3	79.3	225.8	83.3	209.9	92.3
	10	256.6	70.7	244.2	77.3	239.0	80.2	231.2	84.3	214.6	93.3
	12	268.9	72.5	255.8	79.2	250.4	82.0	242.1	86.2	225.0	95.3
15	287.1	75.3	273.4	82.0	267.6	84.8	258.5	89.1	240.5	98.3	
1004 ELN	5	242.3	70.5	230.6	77.4	225.7	80.2	218.2	84.5	202.8	93.8
	6	249.5	71.2	237.3	78.2	232.4	81.0	224.6	85.4	208.9	94.8
	7	256.8	72.1	244.3	79.1	239.1	82.0	<b>231.2</b>	<b>86.3</b>	214.9	95.8
	8	263.2	73.0	250.5	80.0	245.2	82.9	237.0	87.3	220.4	96.7
	9	269.8	73.9	256.7	80.9	251.1	83.8	243.0	88.1	225.9	97.6
	10	276.2	74.8	262.9	81.8	257.3	84.8	248.8	89.2	231.0	98.6
	12	289.4	76.6	275.3	83.8	269.6	86.7	260.6	91.1	242.2	100.8
15	309.1	79.6	294.3	86.7	288.0	89.7	278.3	94.3	258.8	103.9	
1104 ELN	5	266.3	83.4	253.5	91.6	248.1	94.9	239.8	100.0		
	6	274.2	84.4	260.8	92.6	255.4	96.0	246.8	101.2		
	7	282.2	85.4	268.5	93.7	262.8	97.1	<b>254.1</b>	<b>102.2</b>		
	8	289.3	86.4	275.3	94.7	269.5	98.1	260.5	103.3		
	9	296.5	87.5	282.1	95.8	276.0	99.3	267.1	104.4		
	10	303.6	88.6	288.9	96.9	282.7	100.4	273.4	105.6		
	12	318.0	90.7	302.6	99.2	296.3	102.7	286.4	107.9		
15	339.7	94.2	323.4	102.7	316.6	106.2	305.8	111.6			
1204 ELN	5	289.9	97.5	276.0	107.0	270.1	110.9	261.1	116.9		
	6	298.6	98.6	284.0	108.2	278.1	112.1	268.8	118.2		
	7	307.3	99.8	292.4	109.4	286.2	113.5	<b>276.7</b>	<b>119.4</b>		
	8	315.0	101.0	299.8	110.6	293.5	114.7	283.6	120.7		
	9	322.9	102.2	307.2	112.0	300.5	116.0	290.8	121.9		
	10	330.6	103.5	314.6	113.2	307.9	117.3	297.8	123.4		
	12	346.3	106.0	329.5	115.9	322.6	120.0	311.9	126.1		
15	369.9	110.1	352.2	119.9	344.7	124.1	333.0	130.4			

Notes : - LWT : Leaving water temperature.  
 - Power input data are given for compressors only.

# Heating Capacities - VLH STD/HSE-ELN Version

VLH STD/HSE models	LWT (°C)	Ambient coil entering air temperature (°C)													
		-5		-3		0		5		7		10		15	
		Heat. cap. (kW)	Input power (kW)	Heat. cap. (kW)	Input power (kW)	Heat. cap. (kW)	Input power (kW)	Heat. cap. (kW)	Input power (kW)	Heat. cap. (kW)	Input power (kW)	Heat. cap. (kW)	Input power (kW)	Heat. cap. (kW)	Input power (kW)
524 ELN	30	104.9	31.0	110.4	31.1	119.3	31.2	134.9	31.6	141.8	31.8	152.7	32.2	173.0	32.7
	35	103.5	36.4	110.0	34.8	118.6	34.9	133.5	35.3	140.1	35.5	150.7	35.9	170.0	36.4
	40	102.3	40.9	108.9	39.0	118.0	39.1	132.3	39.6	138.6	39.7	148.6	40.1	167.0	40.7
	45	101.2	45.9	107.6	43.8	116.7	44.0	131.2	44.4	<b>137.1</b>	<b>44.6</b>	146.7	44.9	164.0	45.5
	50					115.4	49.7	130.5	50.0	136.0	50.2	144.9	50.4	161.1	51.0
604 ELN	30	119.6	35.8	125.9	35.9	136.1	36.0	153.9	36.5	161.7	36.8	174.2	37.1	197.4	37.7
	35	118.1	42.1	125.4	40.2	135.3	40.3	152.3	40.8	159.8	41.0	171.9	41.4	193.9	42.1
	40	116.7	47.2	124.2	45.0	134.7	45.2	150.9	45.7	158.1	45.9	169.5	46.3	190.5	47.0
	45	115.4	53.0	122.8	50.6	133.1	50.8	149.7	51.2	<b>156.4</b>	<b>51.5</b>	167.3	51.9	187.1	52.6
	50					131.7	57.4	148.9	57.7	155.1	57.9	165.3	58.2	183.8	58.9
704 ELN	30	140.5	42.2	147.9	42.3	159.8	42.4	180.8	43.0	189.9	43.3	204.6	43.8	231.8	44.5
	35	138.7	49.6	147.3	47.3	158.9	47.5	178.9	48.1	187.7	48.4	201.9	48.8	227.8	49.6
	40	137.0	55.6	145.9	53.1	158.2	53.2	177.3	53.8	185.7	54.1	199.1	54.6	223.7	55.4
	45	135.6	62.5	144.2	59.6	156.3	59.9	175.8	60.4	<b>183.7</b>	<b>60.7</b>	196.6	61.1	219.7	62.0
	50					154.7	67.7	174.9	68.0	182.2	68.3	194.2	68.7	215.8	69.4
804 ELN	30	154.8	43.9	162.9	44.0	176.1	44.1	199.2	44.7	209.3	45.1	225.5	45.5	255.4	46.3
	35	152.8	51.6	162.3	49.2	175.1	49.3	197.1	50.0	206.9	50.3	222.4	50.7	251.0	51.6
	40	151.0	57.8	160.7	55.1	174.3	55.3	195.3	56.0	204.6	56.2	219.4	56.7	246.5	57.5
	45	149.4	65.0	158.9	62.0	172.2	62.2	193.7	62.8	<b>202.4</b>	<b>63.1</b>	216.6	63.5	242.1	64.4
	50					170.4	70.4	192.7	70.7	200.8	71.0	213.9	71.4	237.8	72.2
904 ELN	30	177.8	49.4	187.1	49.6	202.2	49.7	228.7	50.4	240.3	50.8	258.9	51.3	293.3	52.1
	35	175.5	58.1	186.4	55.5	201.0	55.6	226.4	56.3	237.5	56.7	255.4	57.2	288.2	58.1
	40	173.4	65.1	184.5	62.1	200.1	62.4	224.3	63.1	235.0	63.4	251.9	63.9	283.1	64.8
	45	171.5	73.2	182.4	69.8	197.8	70.1	222.4	70.7	<b>232.4</b>	<b>71.1</b>	248.7	71.6	278.0	72.6
	50					195.7	79.3	221.2	79.7	230.5	80.0	245.6	80.4	273.1	81.3
1004 ELN	30	187.0	54.8	196.8	54.9	212.7	55.1	240.6	55.9	252.8	56.3	272.4	56.8	308.6	57.8
	35	184.6	64.4	196.1	61.5	211.5	61.6	238.1	62.4	249.9	62.8	268.7	63.4	303.2	64.4
	40	182.4	72.2	194.1	68.9	210.5	69.1	235.9	69.9	247.2	70.2	265.0	70.8	297.8	71.9
	45	180.4	81.2	191.9	77.4	208.1	77.7	234.0	78.4	<b>244.5</b>	<b>78.8</b>	261.6	79.4	292.4	80.5
	50					205.9	87.9	232.8	88.3	242.5	88.7	258.4	89.1	287.3	90.1
1104 ELN	30	203.7	62.6	214.4	62.8	231.7	63.0	262.0	63.9	275.4	64.3	296.7	65.0	336.1	66.0
	35	201.1	73.6	213.6	70.3	230.3	70.5	259.4	71.4	272.2	71.8	292.7	72.4	330.2	73.6
	40	198.7	82.5	211.4	78.7	229.3	79.0	257.0	79.9	269.2	80.3	288.7	81.0	324.4	82.2
	45	196.5	92.8	209.0	88.5	226.6	88.8	254.8	89.6	<b>266.3</b>	<b>90.1</b>	284.9	90.7	318.5	92.0
	50					224.2	100.5	253.5	101.0	264.2	101.4	281.5	101.9	312.9	103.1
1204 ELN	30	226.4	71.7	238.3	71.9	257.5	72.1	291.3	73.1	306.1	73.6	329.7	74.3	373.6	75.6
	35	223.5	84.2	237.4	80.4	256.0	80.6	288.3	81.7	302.5	82.2	325.3	82.9	367.0	84.2
	40	220.8	94.4	235.0	90.1	254.9	90.4	285.6	91.4	299.3	91.9	320.9	92.7	360.5	94.0
	45	218.4	106.2	232.4	101.2	251.9	101.7	283.3	102.6	<b>296.0</b>	<b>103.1</b>	316.7	103.8	354.0	105.3
	50					249.2	115.0	281.8	115.6	293.6	116.0	312.9	116.6	347.8	117.9

Notes : - LWT : Leaving water temperature.  
 - Power input data are given for compressors only.  
 - Heating capacities refer to instant capacity values.

# Cooling Capacities - VLH HT

VLH HT models	LWT (°C)	Condenser entering air temperature (°C)													
		25		30		32		35		40		44		46	
		Cool. cap. (kW)	Input power (kW)	Cool. cap. (kW)	Input power (kW)	Cool. cap. (kW)	Input power (kW)	Cool. cap. (kW)	Input power (kW)	Cool. cap. (kW)	Input power (kW)	Cool. cap. (kW)	Input power (kW)	Cool. cap. (kW)	Input power (kW)
524	5	142.3	36.1	135.5	39.6	132.6	41.1	128.2	43.3	119.1	48.0	113.6	51.1	108.0	54.2
	6	146.6	36.5	139.4	40.1	136.5	41.5	131.9	43.8	122.7	48.5	116.9	51.6	111.2	54.7
	7	150.8	36.9	143.5	40.5	140.4	42.0	<b>135.8</b>	<b>44.2</b>	126.2	49.0	120.3	52.2	114.4	55.3
	8	154.6	37.4	147.1	41.0	144.0	42.4	139.2	44.7	129.4	49.5	123.4	52.6	117.3	55.8
	9	158.5	37.8	150.7	41.4	147.5	42.9	142.7	45.1	132.7	50.0	126.5	53.2	120.3	56.3
	10	162.2	38.3	154.4	41.9	151.1	43.4	146.1	45.7	135.7	50.5	129.4	53.7	123.1	56.9
	12	170.0	39.2	161.7	42.9	158.3	44.4	153.1	46.7	142.3	51.6	135.6	54.8	128.9	58.0
15	181.5	40.8	172.8	44.4	169.2	45.9	163.4	48.3	152.0	53.2	144.9	56.5	137.7	59.7	
604	5	159.0	40.2	151.3	44.1	148.1	45.7	143.2	48.2	133.1	53.5	126.9	56.9	120.7	60.3
	6	163.7	40.6	155.7	44.6	152.5	46.2	147.4	48.7	137.1	54.0	130.6	57.5	124.2	60.9
	7	168.5	41.1	160.3	45.1	156.9	46.8	<b>151.7</b>	<b>49.2</b>	141.0	54.6	134.4	58.0	127.8	61.5
	8	172.7	41.6	164.4	45.6	160.9	47.2	155.5	49.7	144.6	55.1	137.8	58.6	131.1	62.1
	9	177.0	42.1	168.4	46.1	164.8	47.8	159.4	50.2	148.2	55.7	141.3	59.2	134.4	62.7
	10	181.2	42.6	172.5	46.6	168.8	48.3	163.2	50.8	151.6	56.2	144.6	59.8	137.5	63.3
	12	189.9	43.7	180.6	47.8	176.9	49.4	171.0	51.9	158.9	57.5	151.5	61.0	144.0	64.6
15	202.8	45.4	193.1	49.4	189.0	51.1	182.6	53.7	169.8	59.2	161.8	62.9	153.9	66.5	
704	5	184.0	47.7	175.2	52.3	171.4	54.3	165.7	57.2	154.1	63.5	146.9	67.5	139.7	71.6
	6	189.5	48.2	180.2	52.9	176.5	54.8	170.6	57.8	158.7	64.1	151.2	68.2	143.8	72.3
	7	195.0	48.8	185.5	53.5	181.6	55.5	<b>175.6</b>	<b>58.4</b>	163.2	64.8	155.6	68.9	148.0	73.0
	8	199.9	49.4	190.3	54.1	186.3	56.1	180.0	59.1	167.4	65.4	159.5	69.6	151.7	73.7
	9	204.9	50.0	194.9	54.8	190.7	56.7	184.6	59.6	171.6	66.1	163.5	70.2	155.5	74.4
	10	209.8	50.6	199.6	55.4	195.4	57.4	189.0	60.4	175.5	66.7	167.3	70.9	159.2	75.1
	12	219.8	51.9	209.1	56.7	204.7	58.7	197.9	61.7	183.9	68.2	175.3	72.4	166.7	76.7
15	234.7	53.9	223.5	58.7	218.8	60.7	211.3	63.8	196.6	70.3	187.3	74.6	178.1	78.9	
804	5	209.3	52.6	199.2	57.7	195.0	59.8	188.5	63.0	175.2	70.0	167.0	74.5	158.8	78.9
	6	215.5	53.2	205.0	58.4	200.7	60.5	194.0	63.7	180.4	70.7	172.0	75.2	163.5	79.8
	7	221.8	53.8	211.0	59.0	206.5	61.2	<b>199.7</b>	<b>64.4</b>	185.6	71.5	176.9	76.0	168.3	80.5
	8	227.3	54.5	216.4	59.7	211.8	61.8	204.7	65.1	190.3	72.1	181.4	76.7	172.6	81.3
	9	233.0	55.1	221.7	60.4	216.9	62.6	209.9	65.8	195.1	72.9	186.0	77.4	176.9	82.0
	10	238.6	55.8	227.0	61.0	222.2	63.3	214.9	66.6	199.6	73.6	190.3	78.2	181.1	82.8
	12	250.0	57.2	237.8	62.5	232.8	64.7	225.1	68.0	209.2	75.2	199.4	79.9	189.6	84.6
15	267.0	59.4	254.2	64.7	248.8	66.9	240.4	70.3	223.6	77.5	213.0	82.3	202.5	87.0	
904	5	240.5	59.8	228.9	65.6	224.1	68.0	216.6	71.6	201.3	79.6	191.9	84.6	182.5	89.7
	6	247.7	60.4	235.6	66.3	230.7	68.7	222.9	72.5	207.4	80.4	197.6	85.5	187.9	90.6
	7	254.9	61.2	242.5	67.1	237.3	69.6	<b>229.5</b>	<b>73.2</b>	213.3	81.2	203.3	86.4	193.4	91.5
	8	261.3	61.9	248.7	67.8	243.4	70.3	235.2	74.0	218.7	82.0	208.5	87.2	198.3	92.4
	9	267.8	62.6	254.8	68.6	249.3	71.1	241.2	74.8	224.2	82.8	213.7	88.0	203.3	93.2
	10	274.2	63.5	260.9	69.4	255.4	71.9	247.0	75.6	229.3	83.7	218.7	88.9	208.1	94.2
	12	287.3	65.0	273.3	71.1	267.6	73.6	258.7	77.3	240.4	85.5	229.1	90.8	217.9	96.1
15	306.8	67.5	292.1	73.5	285.9	76.1	276.2	80.0	256.9	88.1	244.8	93.5	232.8	98.9	
1004	5	262.1	62.7	249.5	68.8	244.2	71.3	236.0	75.2	219.4	83.5	209.2	88.8	198.9	94.1
	6	269.9	63.4	256.7	69.6	251.4	72.1	243.0	76.0	226.0	84.3	215.4	89.7	204.8	95.1
	7	277.8	64.2	264.3	70.4	258.6	73.0	<b>250.1</b>	<b>76.8</b>	232.4	85.2	221.6	90.6	210.8	96.0
	8	284.7	64.9	271.0	71.2	265.3	73.8	256.4	77.7	238.4	86.0	227.2	91.5	216.1	96.9
	9	291.8	65.7	277.6	72.0	271.7	74.6	262.9	78.4	244.4	86.9	232.9	92.4	221.5	97.8
	10	298.8	66.6	284.3	72.8	278.3	75.5	269.1	79.4	249.9	87.8	238.3	93.3	226.7	98.8
	12	313.0	68.2	297.8	74.6	291.6	77.2	281.9	81.1	262.0	89.7	249.7	95.3	237.4	100.8
15	334.3	70.8	318.3	77.1	311.6	79.8	301.0	83.9	280.0	92.5	266.8	98.1	253.7	103.8	
1104	5	289.7	73.4	275.8	80.6	269.9	83.5	260.9	88.0	242.6	97.7	231.2	103.9	219.9	110.2
	6	298.4	74.2	283.8	81.5	277.9	84.4	268.6	89.0	249.8	98.7	238.1	105.0	226.4	111.3
	7	307.1	75.1	292.2	82.4	285.9	85.4	<b>276.5</b>	<b>89.9</b>	257.0	99.8	245.0	106.1	233.0	112.4
	8	314.8	76.0	299.6	83.3	293.3	86.3	283.4	90.9	263.5	100.7	251.2	107.1	238.9	113.4
	9	322.6	76.9	306.9	84.3	300.3	87.3	290.6	91.8	270.2	101.7	257.5	108.1	244.9	114.5
	10	330.3	77.9	314.4	85.2	307.7	88.3	297.5	92.9	276.3	102.7	263.5	109.2	250.7	115.6
	12	346.1	79.8	329.2	87.3	322.4	90.3	311.7	94.9	289.6	105.0	276.1	111.5	262.5	118.0
15	369.6	82.9	351.9	90.3	344.5	93.4	332.8	98.2	309.5	108.3	295.0	114.9	280.4	121.5	
1204	5	320.2	83.9	304.8	92.1	298.4	95.5	288.4	100.6	268.1	111.7	255.6	118.9	243.1	126.0
	6	329.8	84.9	313.7	93.2	307.2	96.5	296.9	101.8	276.1	112.9	263.2	120.1	250.2	127.3
	7	339.4	85.9	322.9	94.2	316.0	97.7	<b>305.6</b>	<b>102.8</b>	284.0	114.1	270.8	121.3	257.5	128.5
	8	347.9	86.9	331.1	95.3	324.1	98.7	313.2	103.9	291.3	115.1	277.7	122.4	264.1	129.7
	9	356.6	88.0	339.2	96.4	331.9	99.9	321.2	105.0	298.6	116.3	284.6	123.6	270.7	130.9
	10	365.1	89.1	347.4	97.4	340.0	101.0	328.9	106.2	305.4	117.5	291.2	124.9	277.1	132.2
	12	382.5	91.3	363.9	99.8	356.3	103.3	344.5	108.5	320.1	120.0	305.1	127.5	290.1	135.0
15	408.5	94.8	388.9	103.3	380.7	106.8	367.8	112.3	342.1	123.8	326.0	131.4	309.9	138.9	

Notes : - LWT : Leaving water temperature.  
 - Power input data are given for compressors only.

# Heating Capacities - VLH HT

VLH HT models	LWT (°C)	Ambient coil entering air temperature (°C)													
		-5		-3		0		5		7		10		15	
		Heat. cap. (kW)	Input power (kW)	Heat. cap. (kW)	Input power (kW)	Heat. cap. (kW)	Input power (kW)	Heat. cap. (kW)	Input power (kW)	Heat. cap. (kW)	Input power (kW)	Heat. cap. (kW)	Input power (kW)	Heat. cap. (kW)	Input power (kW)
524	30	115.4	31.0	121.5	31.1	131.3	31.2	148.5	31.6	156.0	31.8	168.1	32.2	190.4	32.7
	35	113.9	36.4	121.0	34.8	130.5	34.9	147.0	35.3	154.2	35.5	165.8	35.9	187.1	36.4
	40	112.6	40.9	119.8	39.0	129.9	39.1	145.6	39.6	152.6	39.7	163.6	40.1	183.8	40.7
	45	111.4	45.9	118.5	43.8	128.4	44.0	144.4	44.4	<b>150.9</b>	<b>44.6</b>	161.5	44.9	180.5	45.5
	50	110.2	52.6	117.2	49.7	127.1	49.7	143.7	50.0	149.7	50.2	159.5	50.4	177.3	51.0
604	30	130.4	35.7	137.3	35.8	148.3	35.9	167.8	36.4	176.3	36.6	189.9	37.0	215.2	37.6
	35	128.7	41.9	136.7	40.0	147.5	40.1	166.1	40.6	174.3	40.9	187.4	41.2	211.4	41.9
	40	127.2	47.0	135.4	44.8	146.8	45.0	164.5	45.5	172.4	45.7	184.8	46.1	207.7	46.8
	45	125.8	52.8	133.8	50.4	145.1	50.6	163.2	51.0	<b>170.5</b>	<b>51.3</b>	182.4	51.7	203.9	52.4
	50	124.5	60.5	132.5	57.2	143.6	57.2	162.3	57.5	169.1	57.7	180.2	58.0	200.3	58.7
704	30	153.5	42.1	161.6	42.2	174.6	42.4	197.5	43.0	207.5	43.3	223.6	43.7	253.3	44.4
	35	151.5	49.5	161.0	47.3	173.6	47.4	195.5	48.0	205.1	48.3	220.6	48.7	248.9	49.5
	40	149.7	55.5	159.4	53.0	172.8	53.1	193.7	53.8	202.9	54.0	217.6	54.5	244.5	55.3
	45	148.1	62.4	157.5	59.5	170.8	59.8	192.1	60.3	<b>200.7</b>	<b>60.6</b>	214.7	61.0	240.0	61.9
	50	146.5	71.4	155.9	67.6	169.0	67.6	191.1	67.9	199.1	68.2	212.1	68.5	235.8	69.3
804	30	171.4	44.1	180.3	44.3	194.9	44.4	220.4	45.0	231.6	45.3	249.5	45.8	282.7	46.5
	35	169.1	51.9	179.6	49.5	193.8	49.7	218.2	50.3	228.9	50.6	246.2	51.1	277.8	51.9
	40	167.1	58.2	177.9	55.5	192.9	55.7	216.2	56.3	226.5	56.6	242.8	57.1	272.8	57.9
	45	165.3	65.4	175.8	62.4	190.6	62.6	214.4	63.2	<b>224.0</b>	<b>63.5</b>	239.7	63.9	267.9	64.8
	50	163.5	74.9	174.0	70.8	188.6	70.8	213.2	71.2	222.2	71.4	236.8	71.8	263.2	72.6
904	30	196.3	49.6	206.6	49.8	223.2	49.9	252.5	50.6	265.3	51.0	285.9	51.5	323.8	52.3
	35	193.7	58.3	205.8	55.7	222.0	55.8	249.9	56.5	262.2	56.9	282.0	57.4	318.2	58.3
	40	191.4	65.4	203.7	62.4	220.9	62.6	247.6	63.3	259.4	63.6	278.2	64.2	312.5	65.1
	45	189.4	73.5	201.4	70.1	218.4	70.4	245.6	71.0	<b>256.6</b>	<b>71.4</b>	274.6	71.9	306.9	72.9
	50	187.3	84.2	199.4	79.6	216.1	79.6	244.3	80.0	254.5	80.3	271.2	80.8	301.5	81.7
1004	30	209.4	55.1	220.3	55.3	238.1	55.4	269.3	56.2	283.0	56.6	304.9	57.2	345.4	58.1
	35	206.6	64.8	219.5	61.9	236.8	62.0	266.6	62.8	279.7	63.2	300.8	63.8	339.4	64.8
	40	204.2	72.6	217.3	69.3	235.7	69.5	264.1	70.3	276.7	70.7	296.7	71.3	333.4	72.3
	45	202.0	81.7	214.9	77.9	232.9	78.2	261.9	78.9	<b>273.7</b>	<b>79.3</b>	292.9	79.9	327.3	81.0
	50	199.8	93.5	212.7	88.4	230.5	88.4	260.6	88.9	271.5	89.2	289.3	89.7	321.6	90.7
1104	30	233.7	63.5	245.9	63.7	265.8	63.9	300.6	64.8	315.9	65.3	340.3	65.9	385.5	67.0
	35	230.7	74.7	245.0	71.3	264.3	71.5	297.6	72.4	312.2	72.8	335.7	73.5	378.8	74.7
	40	227.9	83.7	242.6	79.9	263.0	80.2	294.8	81.1	308.9	81.4	331.2	82.2	372.1	83.4
	45	225.5	94.1	239.8	89.8	260.0	90.1	292.4	90.9	<b>305.5</b>	<b>91.4</b>	326.9	92.0	365.4	93.3
	50	223.0	107.8	237.4	101.9	257.2	101.9	290.8	102.5	303.1	102.8	322.9	103.4	359.0	104.6
1204	30	261.2	71.9	274.9	72.1	297.1	72.3	336.0	73.4	353.1	73.9	380.4	74.6	431.0	75.9
	35	257.8	84.6	273.9	80.7	295.4	80.9	332.6	82.0	349.0	82.5	375.3	83.2	423.5	84.6
	40	254.8	94.8	271.2	90.5	294.0	90.8	329.5	91.8	345.3	92.2	370.2	93.0	415.9	94.4
	45	252.0	106.6	268.1	101.6	290.6	102.1	326.8	103.0	<b>341.5</b>	<b>103.5</b>	365.4	104.2	408.4	105.7
	50	249.3	122.0	265.3	115.4	287.5	115.4	325.1	116.0	338.8	116.4	361.0	117.1	401.3	118.4

Notes : - LWT : Leaving water temperature.  
 - Power input data are given for compressors only.  
 - Heating capacities refer to instant capacity values.

# Total Heat Recovery - VLR

VLR Models	LWT °C	Condenser Water Temperature - °C														
		35			40			45			50			55		
		Cooling cap. (kW)	Input power (kW)	Heat recovery (kW)	Cooling cap. (kW)	Input power (kW)	Heat recovery (kW)	Cooling cap. (kW)	Input power (kW)	Heat recovery (kW)	Cooling cap. (kW)	Input power (kW)	Heat recovery (kW)	Cooling cap. (kW)	Input power (kW)	Heat recovery (kW)
524	5	142.5	36.3	169.9	135.7	39.9	166.8	128.3	43.6	163.3	119.3	48.4	159.3	113.7	51.5	156.9
	6	146.8	36.7	174.3	139.6	40.3	170.9	132.1	44.0	167.4	122.9	48.9	163.2	117.1	52.0	160.7
	7	151.0	37.2	178.8	143.7	40.8	175.3	<b>136.0</b>	<b>44.5</b>	<b>171.5</b>	126.4	49.4	167.0	120.5	52.5	164.4
	8	154.8	37.6	182.8	147.3	41.2	179.2	139.4	45.0	175.2	129.6	49.8	170.5	123.6	53.0	167.7
	9	158.7	38.1	186.9	151.0	41.7	183.1	142.9	45.4	179.0	132.9	50.3	174.1	126.7	53.5	171.2
	10	162.5	38.6	191.0	154.6	42.2	187.0	146.4	46.0	182.7	135.9	50.9	177.4	129.6	54.1	174.5
	12	170.2	39.5	199.2	161.9	43.2	194.9	153.3	47.0	190.3	142.5	52.0	184.7	135.8	55.2	181.4
15	181.8	41.0	211.7	173.1	44.7	206.9	163.7	48.6	201.7	152.2	53.6	195.5	145.1	56.9	191.9	
604	5	159.3	40.0	189.3	151.6	43.9	185.8	143.4	48.0	181.8	133.3	53.3	177.3	127.1	56.7	174.6
	6	164.0	40.5	194.3	156.0	44.4	190.4	147.7	48.5	186.4	137.3	53.8	181.6	130.9	57.2	178.7
	7	168.8	40.9	199.3	160.6	44.9	195.2	<b>152.0</b>	<b>49.0</b>	<b>191.0</b>	141.3	54.4	185.8	134.7	57.8	182.9
	8	173.0	41.4	203.8	164.7	45.4	199.6	155.8	49.5	195.1	144.9	54.9	189.8	138.1	58.4	186.6
	9	177.4	41.9	208.3	168.7	45.9	203.9	159.8	50.0	199.3	148.5	55.4	193.8	141.6	58.9	190.5
	10	181.6	42.5	212.9	172.8	46.4	208.3	163.6	50.6	203.5	151.9	56.0	197.5	144.8	59.5	194.1
	12	190.2	43.5	222.1	181.0	47.6	217.1	171.3	51.7	211.9	159.2	57.2	205.6	151.8	60.8	201.9
15	203.2	45.2	236.0	193.5	49.2	230.5	182.9	53.5	224.6	170.2	59.0	217.7	162.2	62.6	213.5	
704	5	184.4	47.8	220.6	175.6	52.4	216.6	166.1	57.3	212.2	154.4	63.6	207.1	147.2	67.6	204.1
	6	189.9	48.3	226.3	180.7	53.0	222.0	171.0	57.9	217.4	159.0	64.2	212.1	151.6	68.3	208.9
	7	195.5	48.9	232.1	186.0	53.6	227.6	<b>176.0</b>	<b>58.5</b>	<b>222.8</b>	163.6	64.9	217.1	155.9	69.0	213.7
	8	200.4	49.5	237.3	190.7	54.2	232.6	180.4	59.2	227.6	167.7	65.5	221.6	159.9	69.7	218.1
	9	205.4	50.1	242.7	195.4	54.9	237.7	185.0	59.7	232.5	172.0	66.2	226.2	163.9	70.3	222.6
	10	210.3	50.7	247.9	200.1	55.4	242.8	189.4	60.5	237.4	175.9	66.9	230.6	167.7	71.1	226.8
	12	220.3	51.9	258.6	209.6	56.8	253.1	198.4	61.8	247.1	184.4	68.3	240.0	175.7	72.6	235.9
15	235.3	53.9	274.8	224.0	58.8	268.6	211.8	63.9	261.9	197.0	70.4	254.1	187.8	74.7	249.4	
804	5	209.6	52.7	249.1	199.5	57.8	244.5	188.7	63.1	239.3	175.5	70.1	233.3	167.3	74.6	229.7
	6	215.8	53.2	255.6	205.3	58.5	250.6	194.3	63.8	245.2	180.7	70.8	239.0	172.2	75.4	235.2
	7	222.1	53.9	262.2	211.3	59.1	256.9	<b>200.0</b>	<b>64.5</b>	<b>251.3</b>	185.9	71.6	244.6	177.2	76.1	240.6
	8	227.7	54.5	268.1	216.7	59.8	262.6	205.0	65.2	256.7	190.6	72.2	249.7	181.7	76.8	245.6
	9	233.4	55.2	274.1	222.0	60.5	268.4	210.2	65.9	262.3	195.4	73.0	255.0	186.3	77.6	250.6
	10	238.9	55.9	280.1	227.4	61.1	274.1	215.2	66.7	267.8	199.9	73.7	259.9	190.6	78.3	255.5
	12	250.3	57.3	292.2	238.2	62.6	285.7	225.4	68.1	278.9	209.5	75.3	270.6	199.7	80.0	265.7
15	267.4	59.5	310.5	254.5	64.8	303.4	240.7	70.5	295.6	223.9	77.7	286.5	213.4	82.4	281.0	
904	5	241.0	60.0	286.0	229.4	65.9	280.5	217.1	71.9	274.5	201.8	79.9	267.6	192.4	85.0	263.5
	6	248.2	60.7	293.5	236.1	66.6	287.6	223.4	72.8	281.4	207.8	80.7	274.1	198.1	85.9	269.7
	7	255.4	61.4	301.0	243.0	67.4	294.9	<b>230.0</b>	<b>73.5</b>	<b>288.3</b>	213.7	81.6	280.5	203.8	86.7	276.0
	8	261.8	62.2	307.8	249.2	68.1	301.4	235.8	74.3	294.6	219.2	82.3	286.5	209.0	87.5	281.7
	9	268.4	62.9	314.7	255.3	68.9	308.0	241.7	75.1	301.0	224.7	83.2	292.5	214.2	88.4	287.5
	10	274.8	63.7	321.6	261.5	69.7	314.6	247.5	76.0	307.3	229.8	84.0	298.1	219.2	89.3	293.0
	12	287.9	65.3	335.5	273.9	71.4	328.0	259.3	77.6	320.0	240.9	85.8	310.4	229.6	91.2	304.8
15	307.5	67.8	356.5	292.7	73.8	348.2	276.8	80.3	339.2	257.5	88.5	328.7	245.4	93.9	322.3	
1004	5	262.0	62.9	308.6	249.4	69.0	302.5	235.9	75.4	295.7	219.3	83.7	287.9	209.1	89.0	283.2
	6	269.8	63.6	316.7	256.6	69.8	310.1	242.9	76.2	303.1	225.9	84.6	294.9	215.3	90.0	290.0
	7	277.6	64.3	324.9	264.2	70.6	318.0	<b>250.0</b>	<b>77.0</b>	<b>310.7</b>	232.3	85.4	301.9	221.5	90.9	296.7
	8	284.6	65.1	332.2	270.9	71.3	325.1	256.3	77.9	317.4	238.3	86.2	308.3	227.1	91.7	302.9
	9	291.7	65.9	339.7	277.5	72.2	332.2	262.8	78.6	324.3	244.3	87.1	314.8	232.8	92.6	309.2
	10	298.7	66.7	347.1	284.2	73.0	339.4	269.0	79.6	331.2	249.8	88.0	320.9	238.2	93.5	315.2
	12	312.9	68.4	362.2	297.7	74.8	353.8	281.8	81.3	344.9	261.9	89.9	334.2	249.6	95.5	327.9
15	334.2	71.0	385.0	318.2	77.3	375.7	300.9	84.1	365.7	279.9	92.7	353.9	266.7	98.4	346.8	
1104	5	290.3	73.5	345.6	276.3	80.7	339.1	261.4	88.1	332.0	243.0	97.8	323.8	231.7	104.1	318.9
	6	298.9	74.3	354.6	284.3	81.6	347.6	269.1	89.1	340.3	250.3	98.8	331.7	238.5	105.1	326.5
	7	307.6	75.2	363.7	292.7	82.5	356.4	<b>277.0</b>	<b>90.0</b>	<b>348.7</b>	257.4	99.9	339.4	245.4	106.2	334.0
	8	315.3	76.1	371.9	300.1	83.4	364.3	283.9	91.0	356.2	264.0	100.8	346.6	251.7	107.2	340.9
	9	323.2	77.0	380.2	307.5	84.4	372.3	291.2	91.9	363.9	270.6	101.8	353.9	258.0	108.2	347.9
	10	330.9	78.0	388.5	314.9	85.3	380.2	298.1	93.0	371.5	276.8	102.9	360.7	264.0	109.3	354.6
	12	346.7	79.9	405.3	329.8	87.4	396.4	312.2	95.0	386.9	290.2	105.1	375.5	276.6	111.6	368.8
15	370.3	83.0	430.6	352.5	90.4	420.8	333.4	98.3	410.1	310.1	108.4	397.5	295.5	115.0	390.0	
1204	5	320.7	84.1	384.5	305.2	92.3	377.7	288.8	100.8	370.1	268.4	111.9	361.4	255.9	119.1	356.3
	6	330.2	85.0	394.5	314.1	93.4	387.1	297.3	102.0	379.3	276.5	113.1	370.1	263.5	120.3	364.7
	7	339.8	86.1	404.6	323.3	94.4	396.8	<b>306.0</b>	<b>103.0</b>	<b>388.6</b>	284.4	114.3	378.7	271.1	121.5	373.0
	8	348.4	87.1	413.7	331.5	95.4	405.6	313.7	104.1	396.9	291.6	115.4	386.7	278.0	122.7	380.7
	9	357.1	88.1	422.9	339.7	96.6	414.5	321.6	105.2	405.5	299.0	116.5	394.7	285.0	123.9	388.4
	10	365.6	89.3	432.1	347.9	97.6	423.2	329.3	106.4	414.0	305.8	117.7	402.3	291.6	125.1	395.9
	12	383.0	91.5	450.7	364.4	100.0	441.2	344.9	108.7	431.0	320.5	120.3	418.8	305.5	127.8	411.6
15	409.1	95.0	478.8	389.4	103.5	468.3	368.3	112.5	456.8	342.6	124.0	443.2	326.5	131.6	435.2	

Notes : - LWT : Leaving water temperature.  
 - Power input data are given for compressors only.

# Evaporator Water Pressure Drop Curves

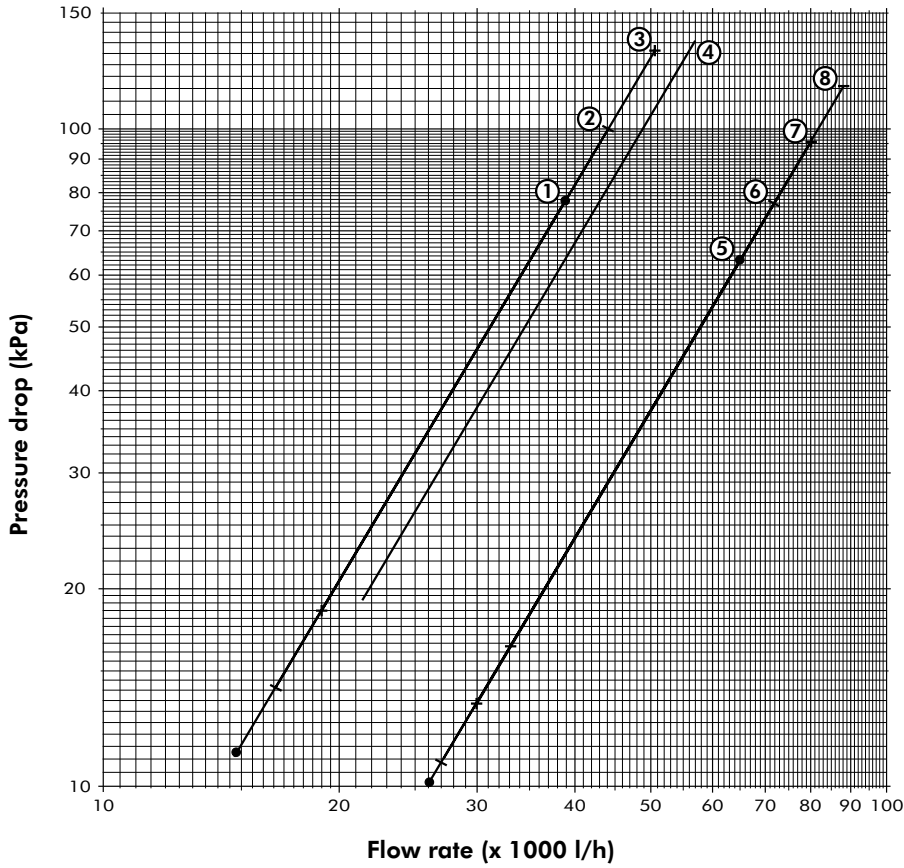

- ① Size 524
- ② Size 604
- ③ Size 704
- ④ Size 804
- ⑤ Size 904
- ⑥ Size 1004
- ⑦ Size 1104
- ⑧ Size 1204

# Desuperheater Water Pressure Drop Curves

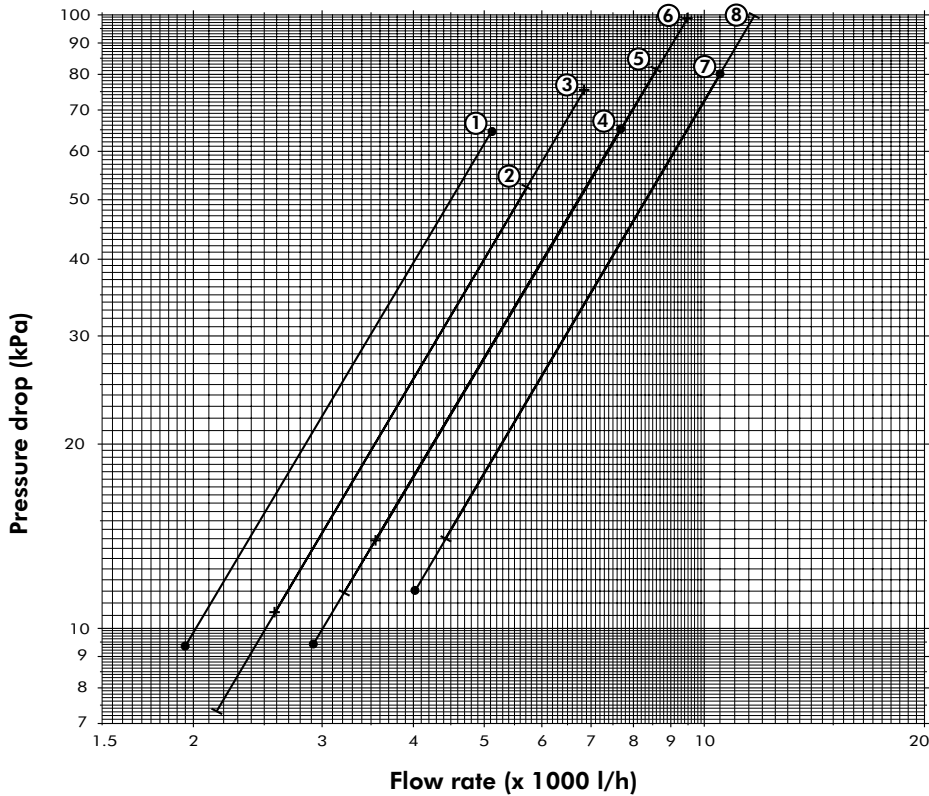

- ① Size 524
- ② Size 604
- ③ Size 704
- ④ Size 804
- ⑤ Size 904
- ⑥ Size 1004
- ⑦ Size 1104
- ⑧ Size 1204

**Note :** Flow rate refers to one condenser only.

# Total Heat Recovery Condenser Water Pressure Drop Curves

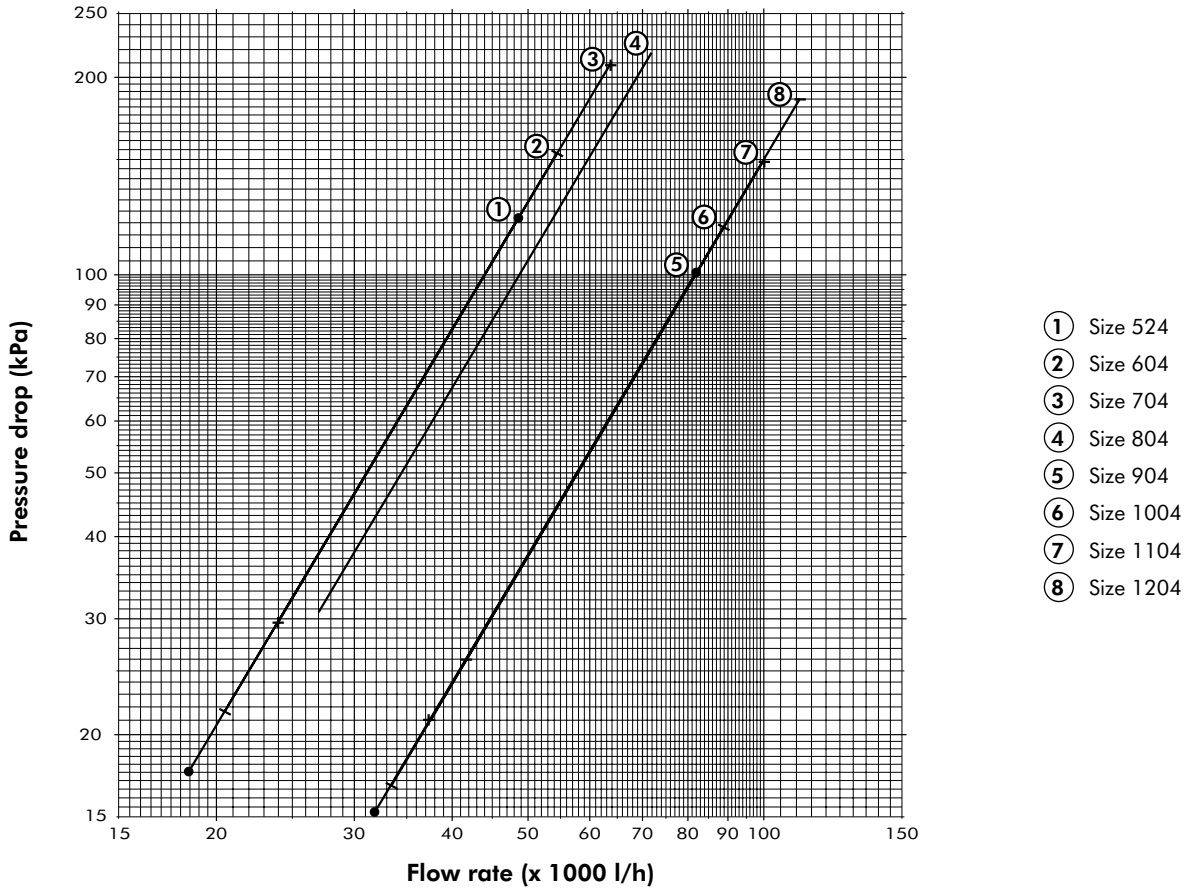

# Water Pump Curves

## Models VLS/VLH 524-604

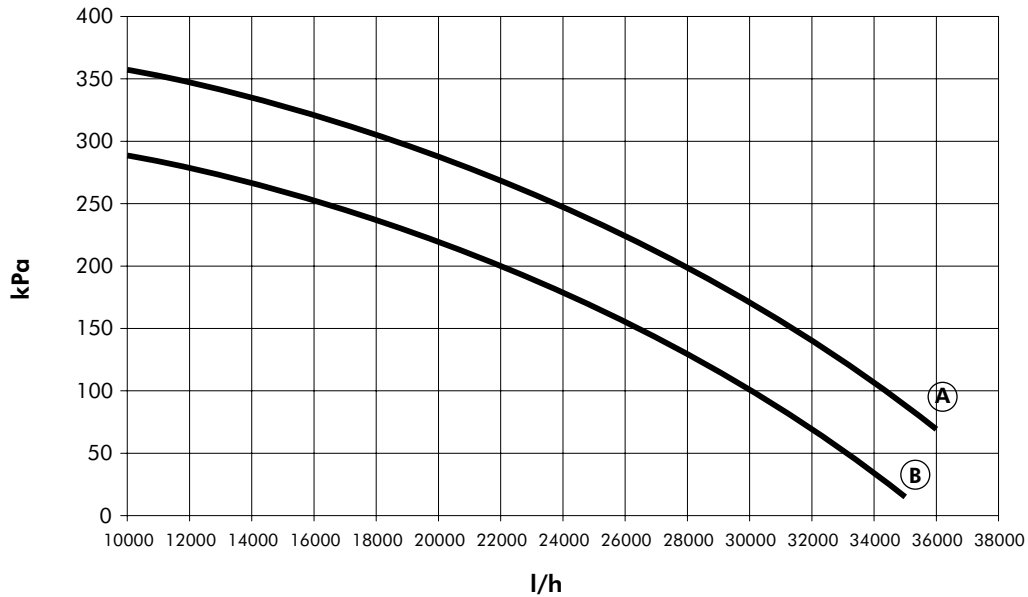

Curve A : High manometric head

Curve B : Low manometric head

# Water Pump Curves (continued)

## Model VLS/VLH 704

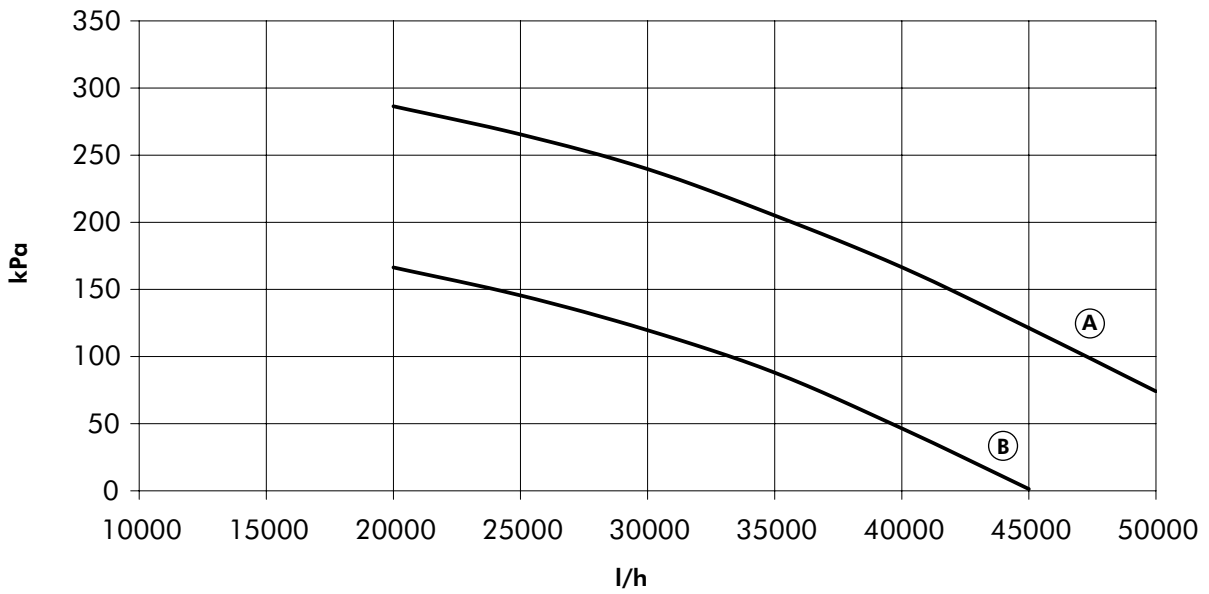

Curve A : High manometric head

Curve B : Low manometric head

## Model VLS/VLH 804

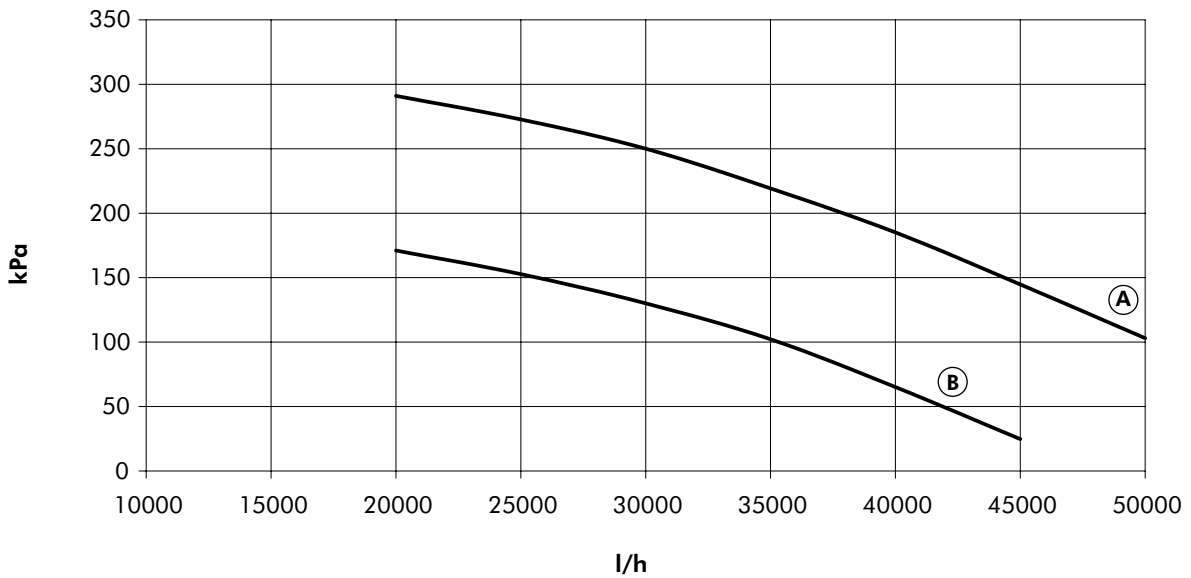

Curve A : High manometric head

Curve B : Low manometric head



# Water Pump Curves (continued)

## Models VLS/VLH 904 & 1004

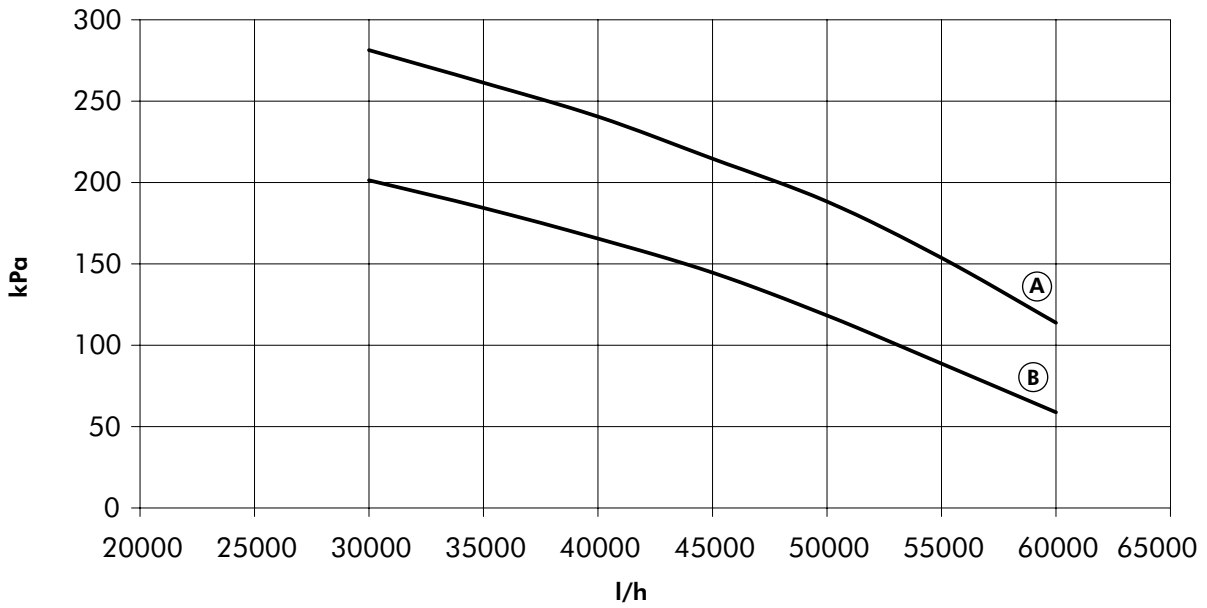

Curve A : High manometric head

Curve B : Low manometric head

## Models VLS/VLH 1104 & 1204

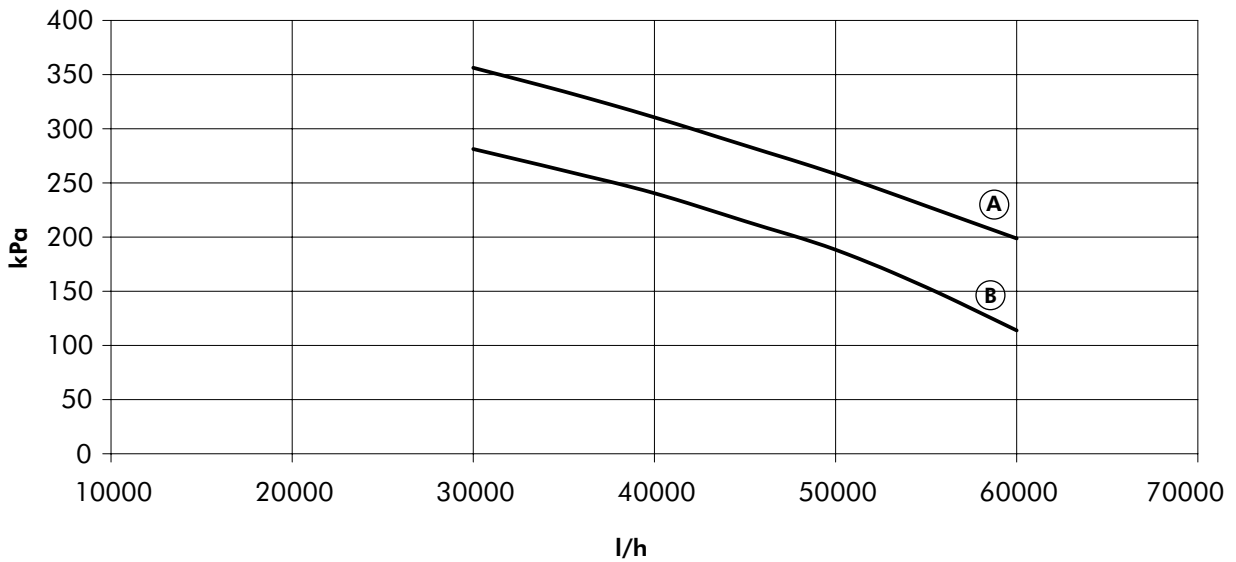

Curve A : High manometric head

Curve B : Low manometric head

# Dimensions

## Models VLS/VLH 524 & 604

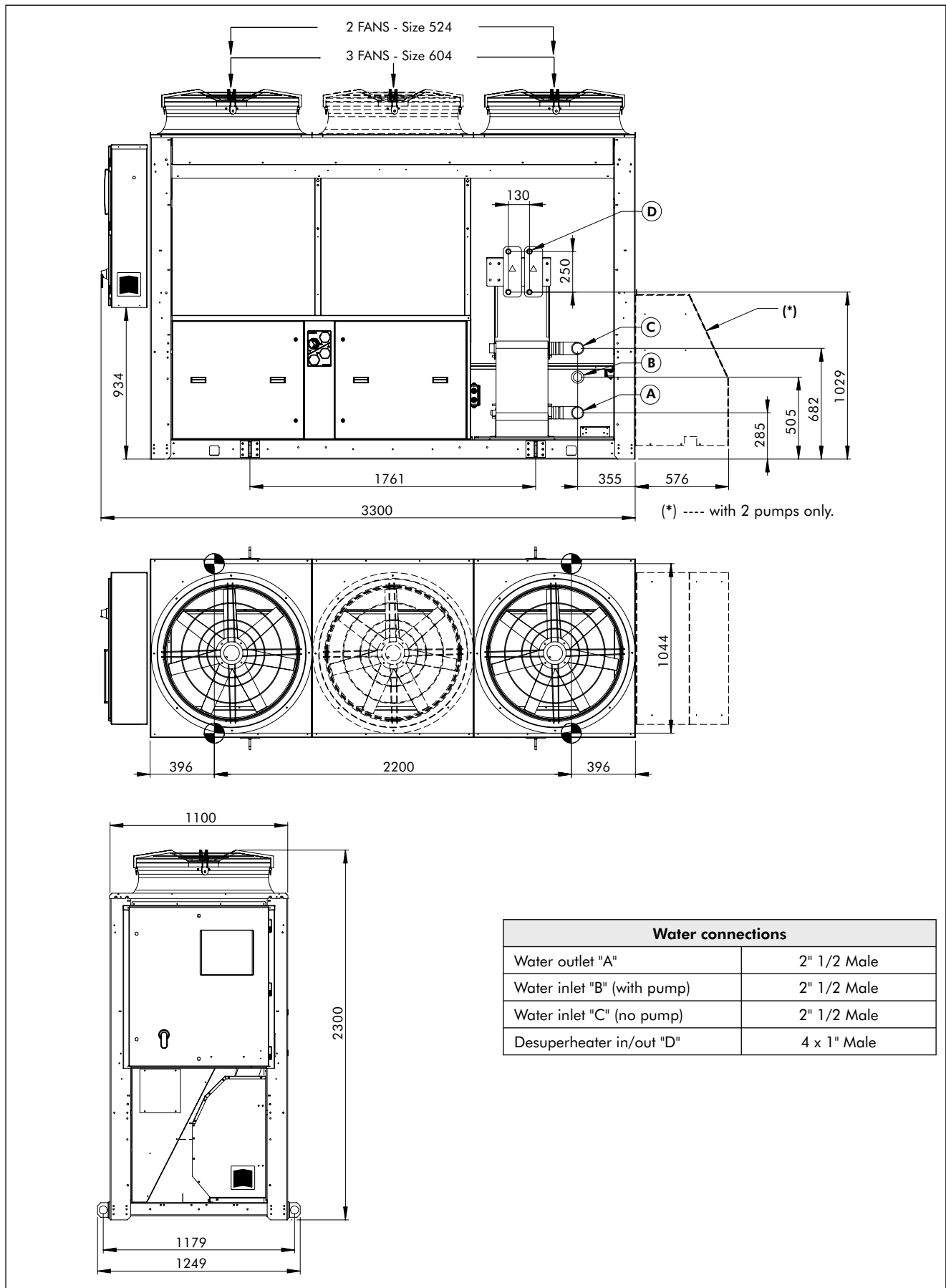

# Dimensions (continued)

## Models VLS/VLH 704 to 1204

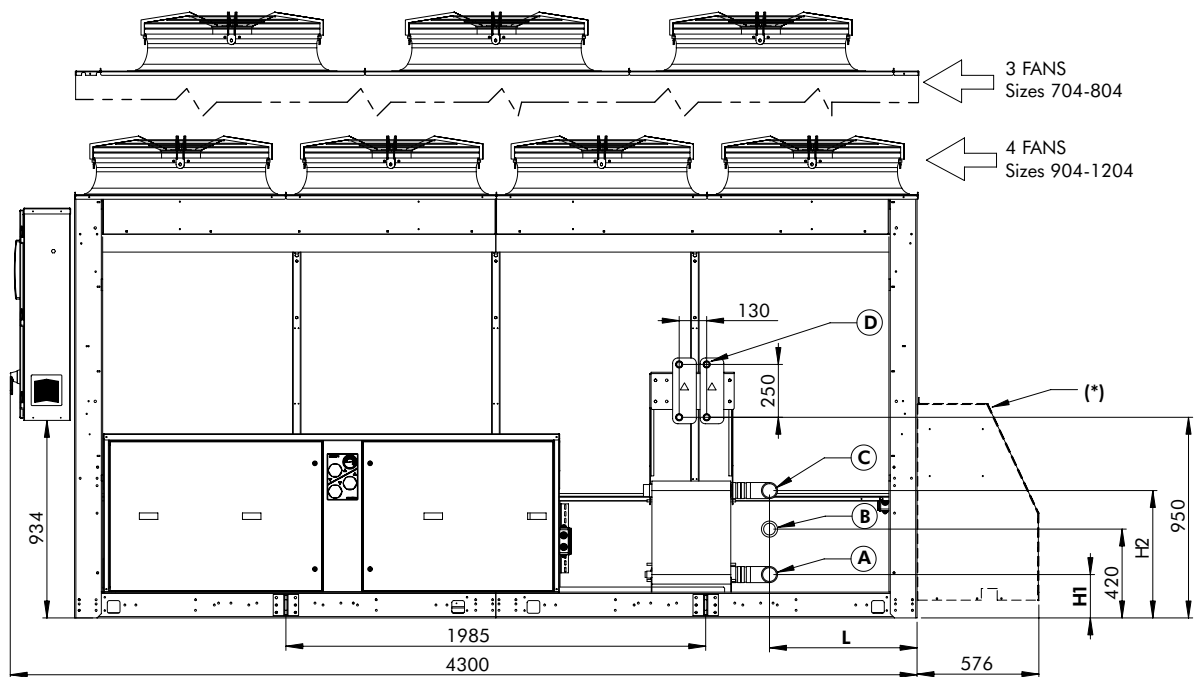

(\*) ---- with 2 pumps only.

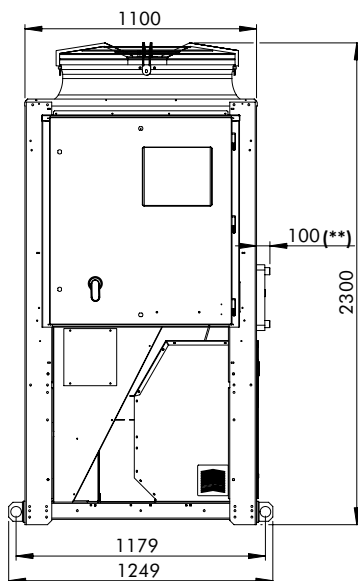
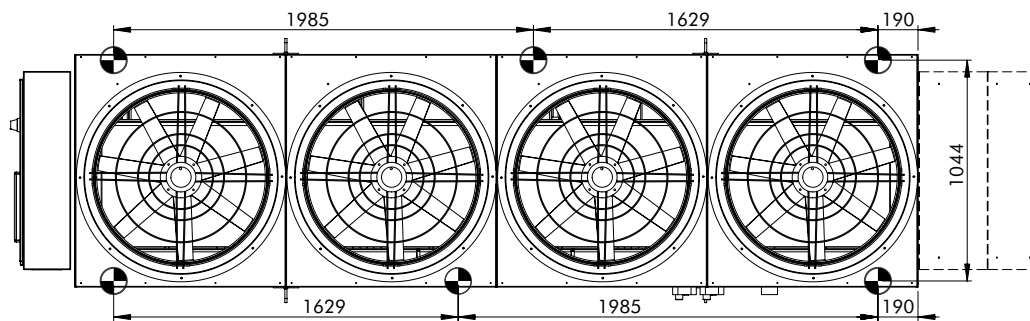

(\*\*) Maximum with desuperheaters.

Dimensions (mm)	704 - 804	904 - 1204
H1	205	213
H2	602	840
L	700	720

Water connections	704 - 804	904 - 1204
Water outlet "A"	2" 1/2 Male	3" Male
Water inlet "B" (with pump)	2" 1/2 Male	3" Male
Water inlet "C" (no pump)	2" 1/2 Male	3" Male
Desuperheater in/out "D"	4 x 2" Male	4 x 2" Male

# Dimensions (continued)

## Models VLS/VLH 524 & 604 with optional on board hydro kit

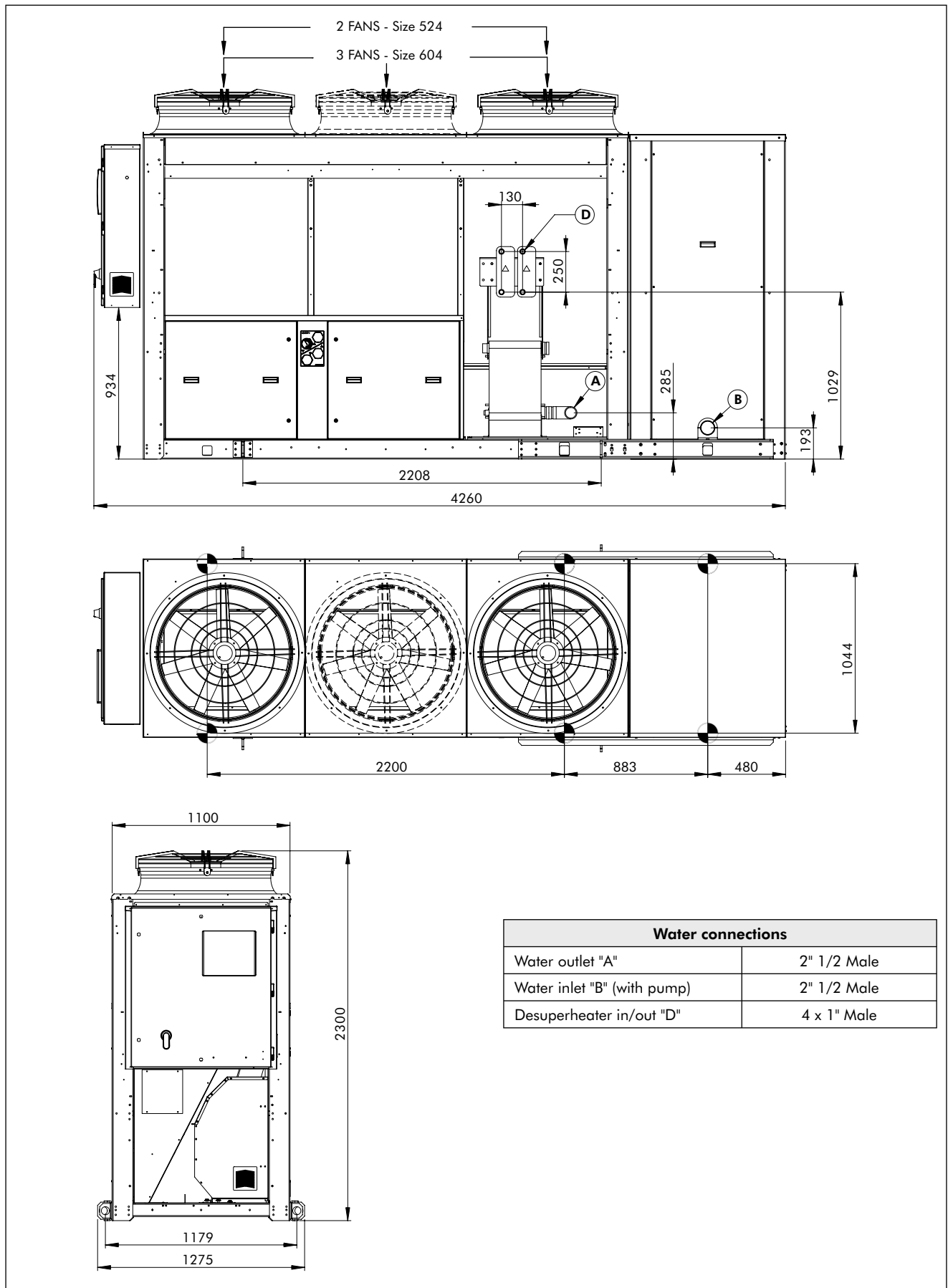

# Dimensions (continued)

## Models VLS/VLH 704 to 1204 with optional on board hydro kit

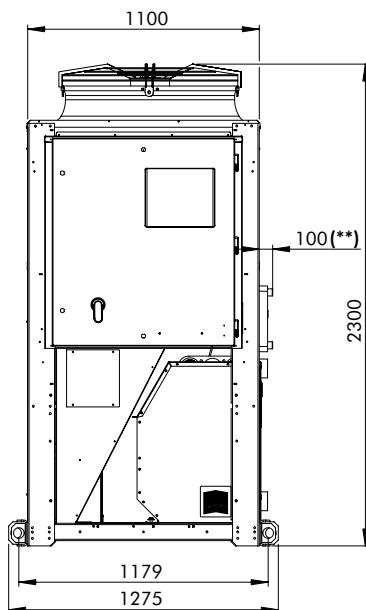
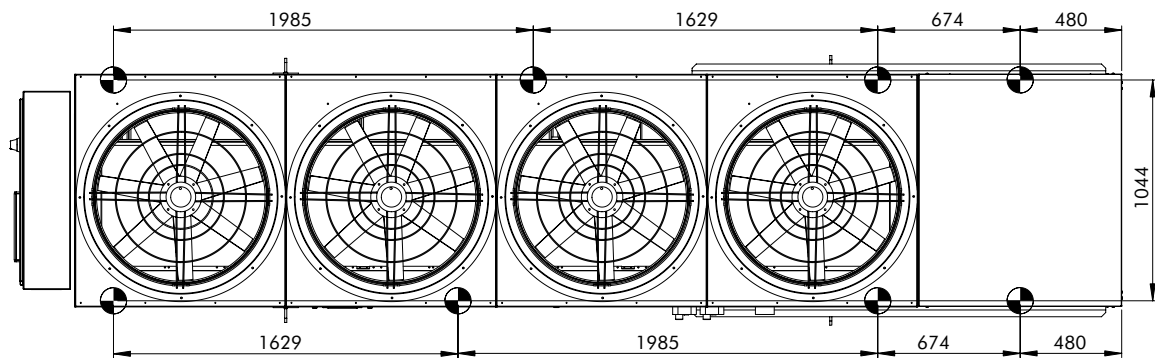
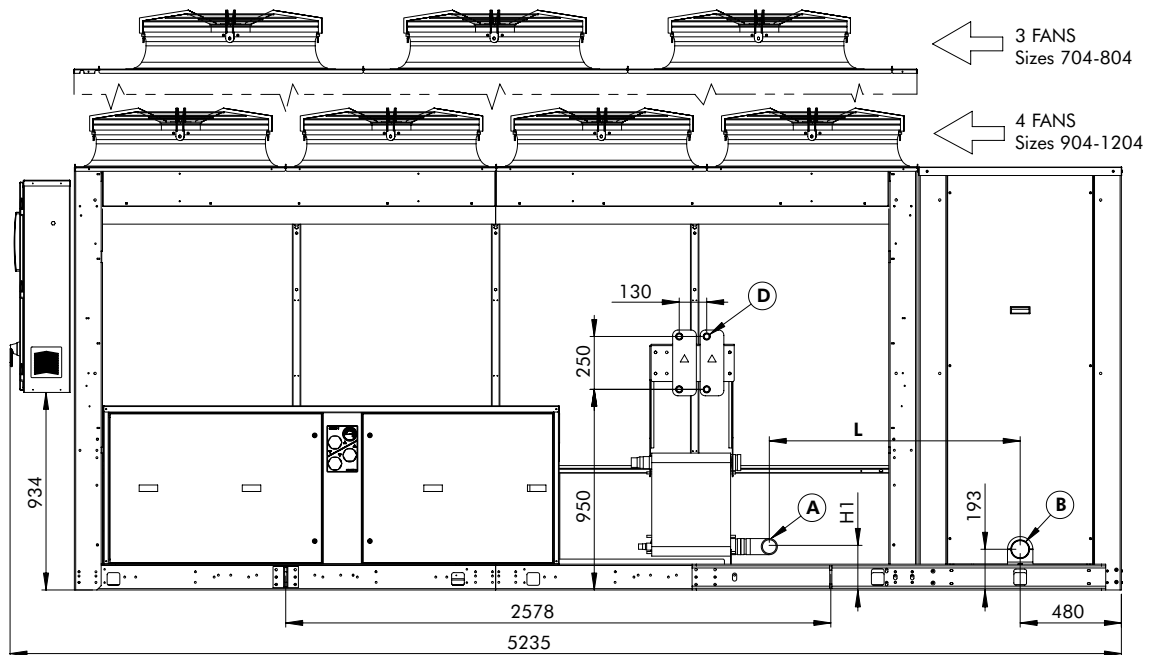

(\*\*) Maximum with desuperheaters.

Dimensions (mm)	704 - 804	904 - 1204
H1	205	213
L	1186	1208

Water connections	704 - 804	904 - 1204
Water outlet "A"	2" 1/2 Male	3" Male
Water inlet "B" (with pump)	2" 1/2 Male	3" Male
Desuperheater in/out "D"	4 x 2" Male	4 x 2" Male

# Dimensions (continued)

## Models VLR 524 & 604

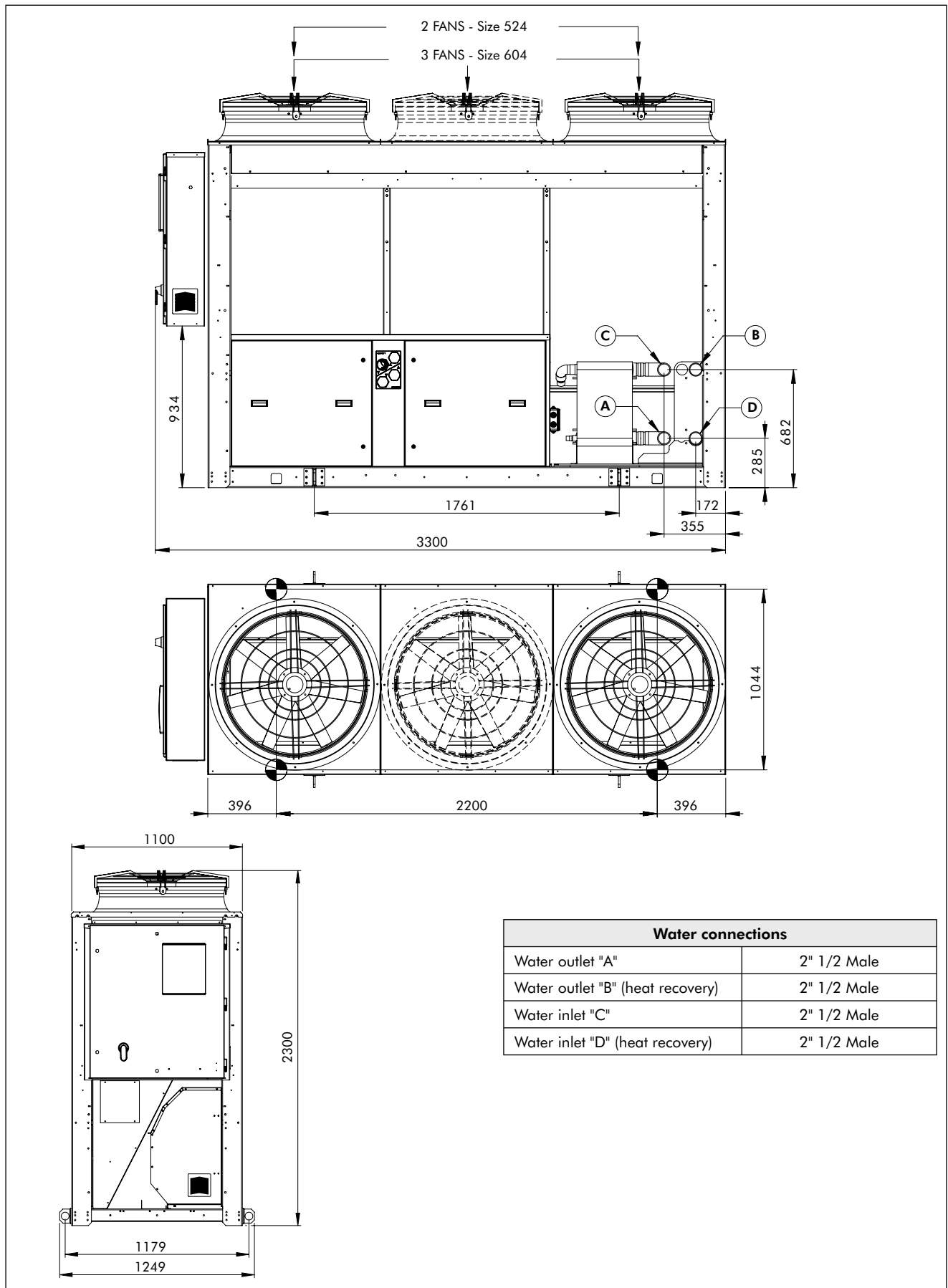

# Dimensions (continued)

## Models VLR 704 to 1204

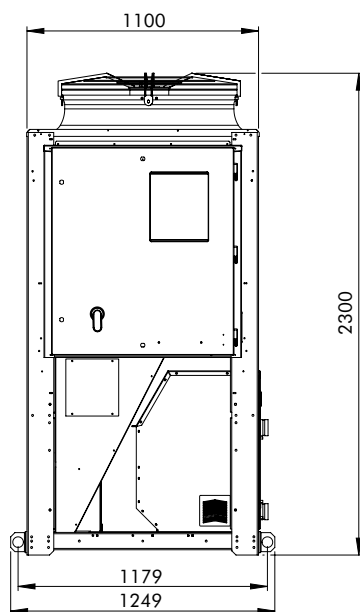
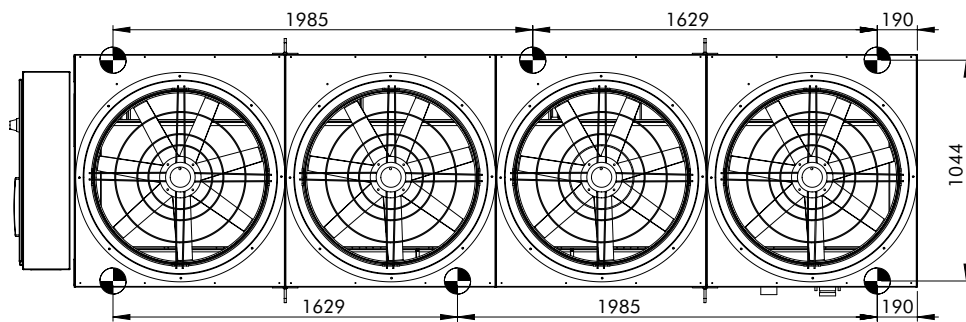
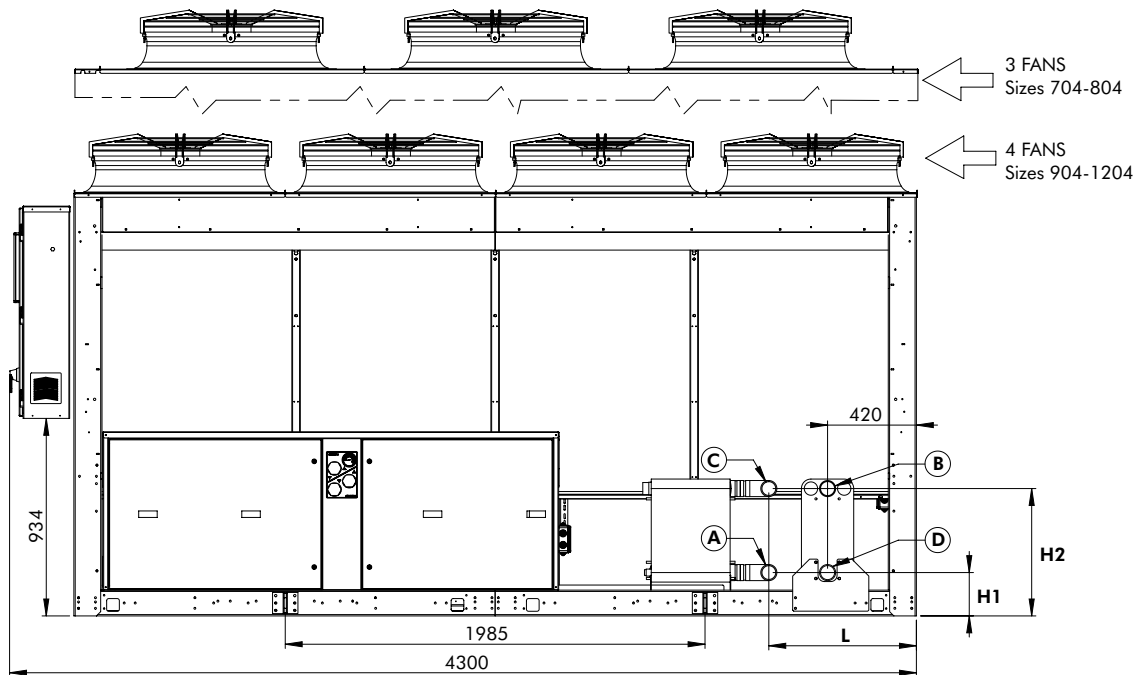

Dimensions (mm)	704 - 804	904 - 1204
H1	205	213
H2	602	840
L	700	720

Water connections	704 - 804	904 - 1204
Water outlet "A"	2" 1/2 Male	3" Male
Water outlet "B" (heat recovery)	2" 1/2 Male	3" Male
Water inlet "C"	2" 1/2 Male	3" Male
Water inlet "D" (heat recovery)	2" 1/2 Male	3" Male

# Space Requirements

## Single unit applications

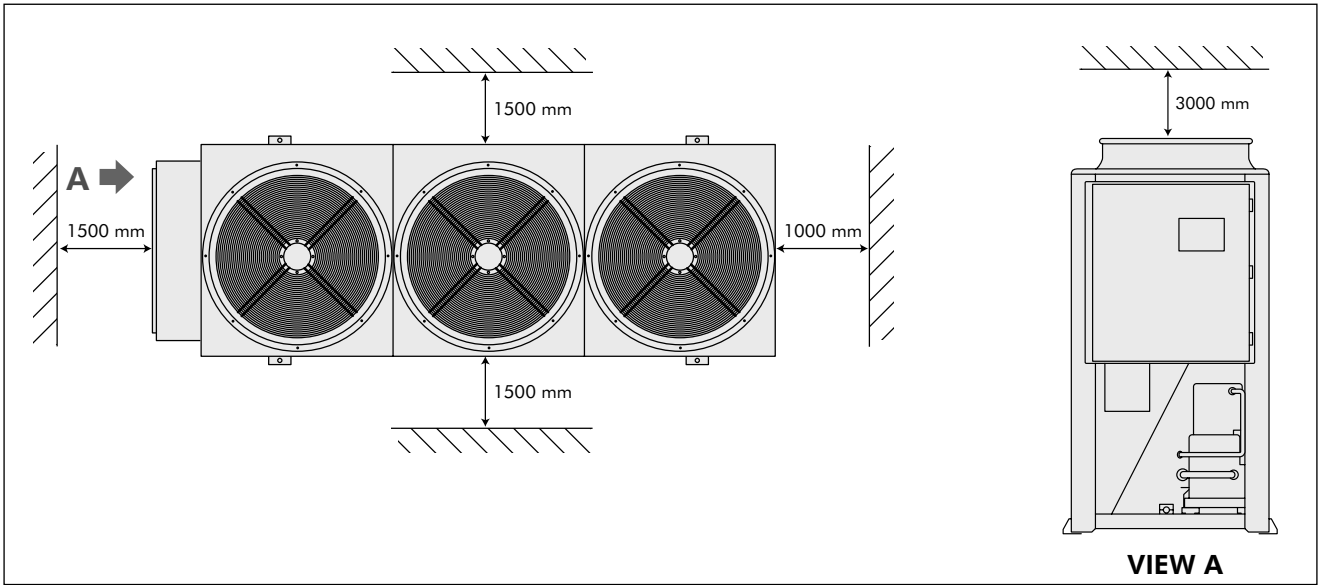

## Multi units applications

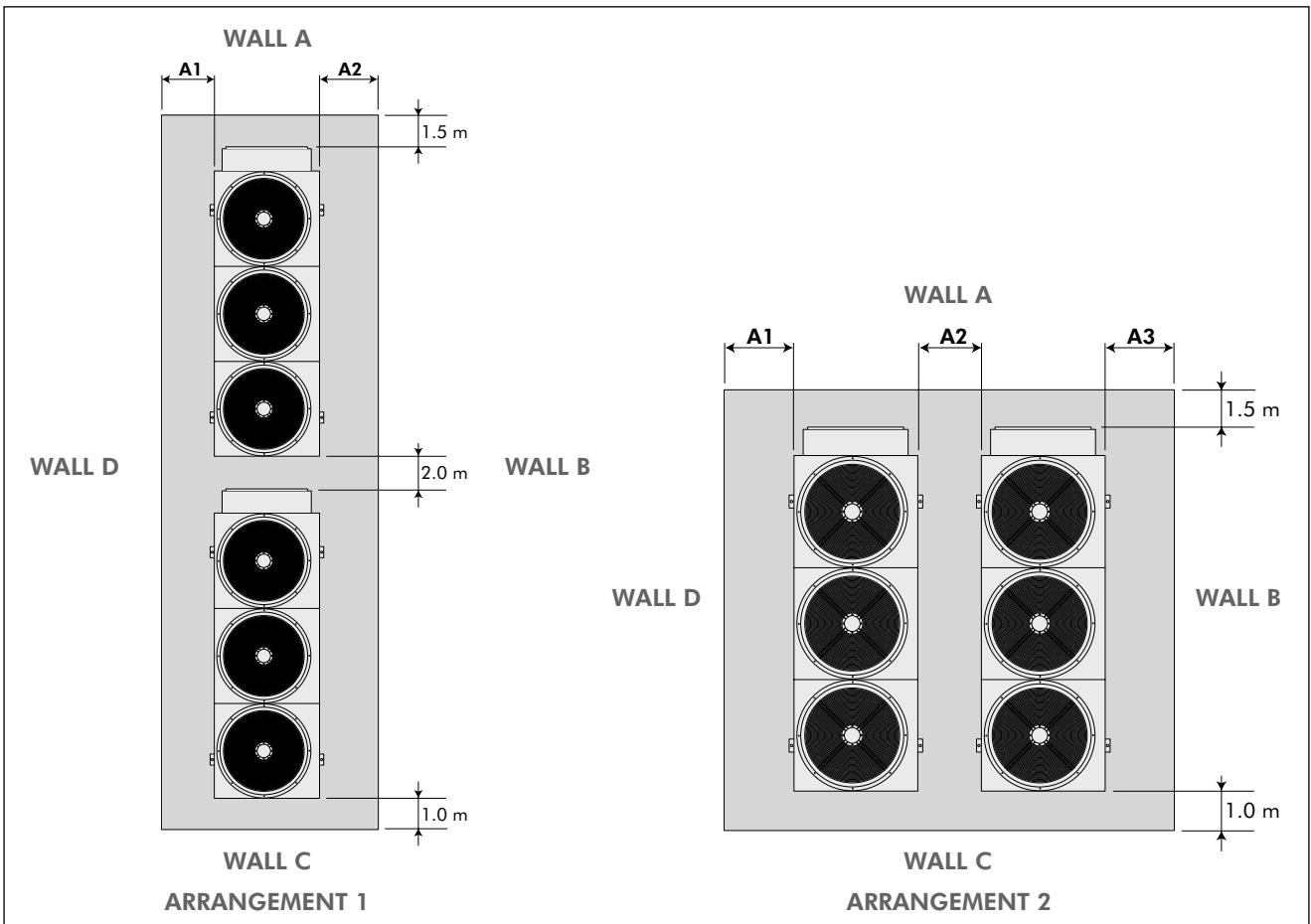

	LOUVRED A & C SOLID B & D			SOLID A & B SOLID C & D			SOLID A & C LOUVRED B & D			LOUVRED A & B SOLID C & D			LOUVRED A & D SOLID B & C		
	A1	A2	A3	A1	A2	A3	A1	A2	A3	A1	A2	A3	A1	A2	A3
<b>ARRANGEMENT 1</b>	1000	1000		1000	1000		800	800		1000	800		800	1000	
<b>ARRANGEMENT 2</b>	1000	1500	1000	1000	2000	1000	800	2000	800	1000	1500	800	800	1500	1000

**Note :** No more than one wall can be higher than the unit.  
The area enclosed by the wall must be kept clear of all obstructions that would impede air flow to the unit.  
Dimensions in mm.



# Remote Hydro Kits (optional) - Dimensions in mm

## Model 500 litres

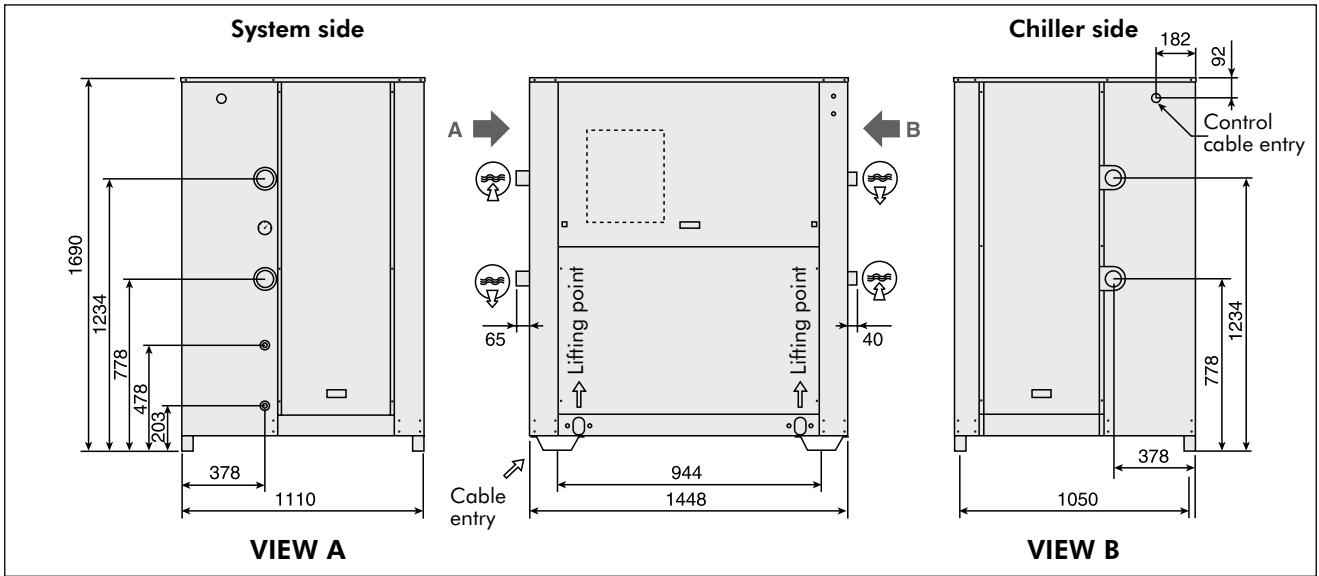

## Models 750 & 1000 litres

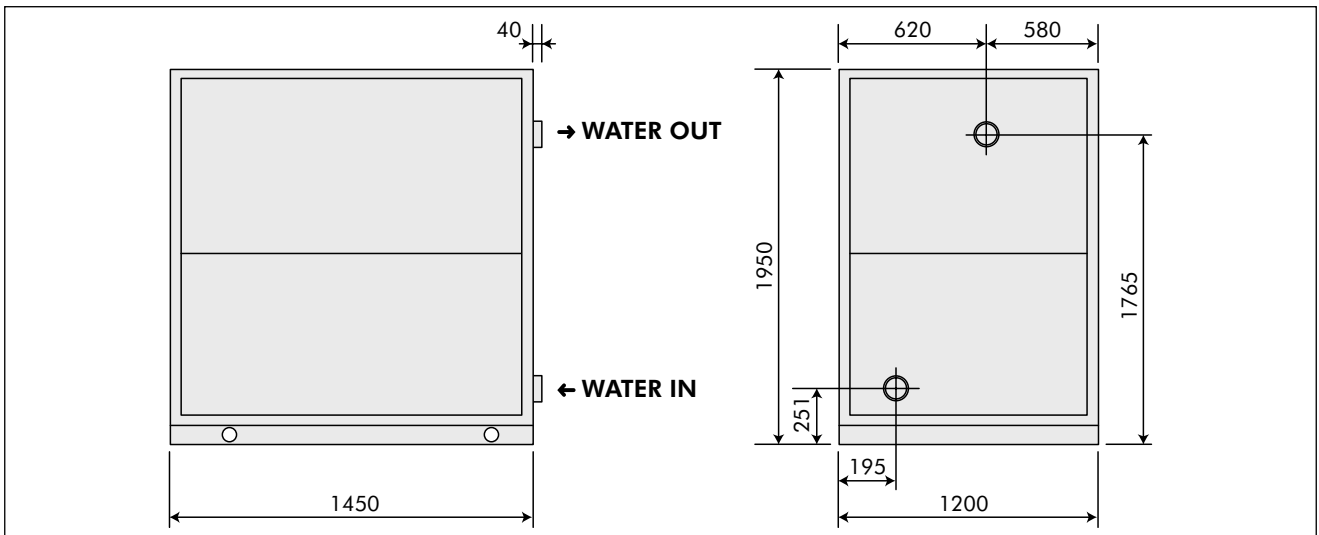

# Notes

---

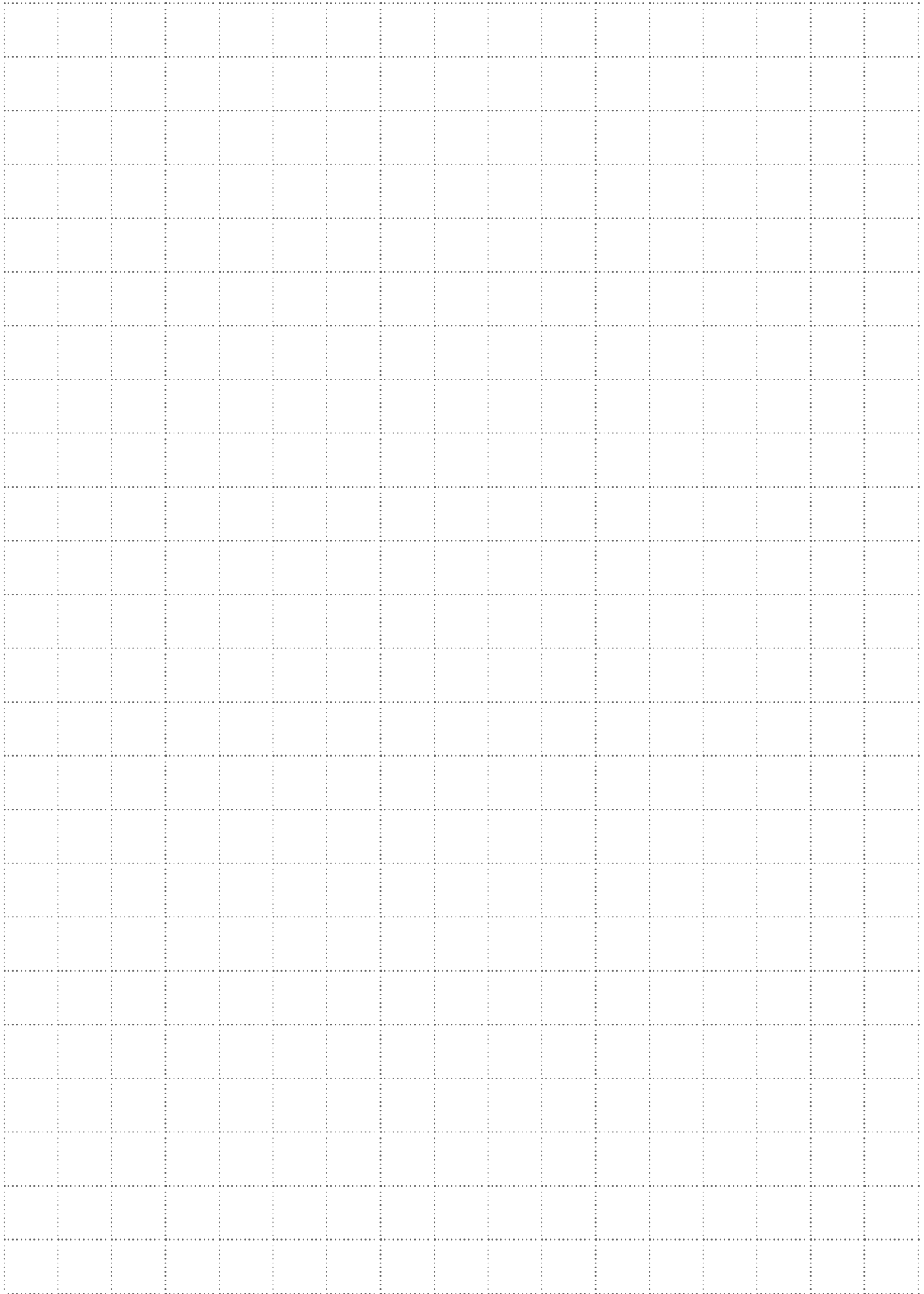

# Notes

---

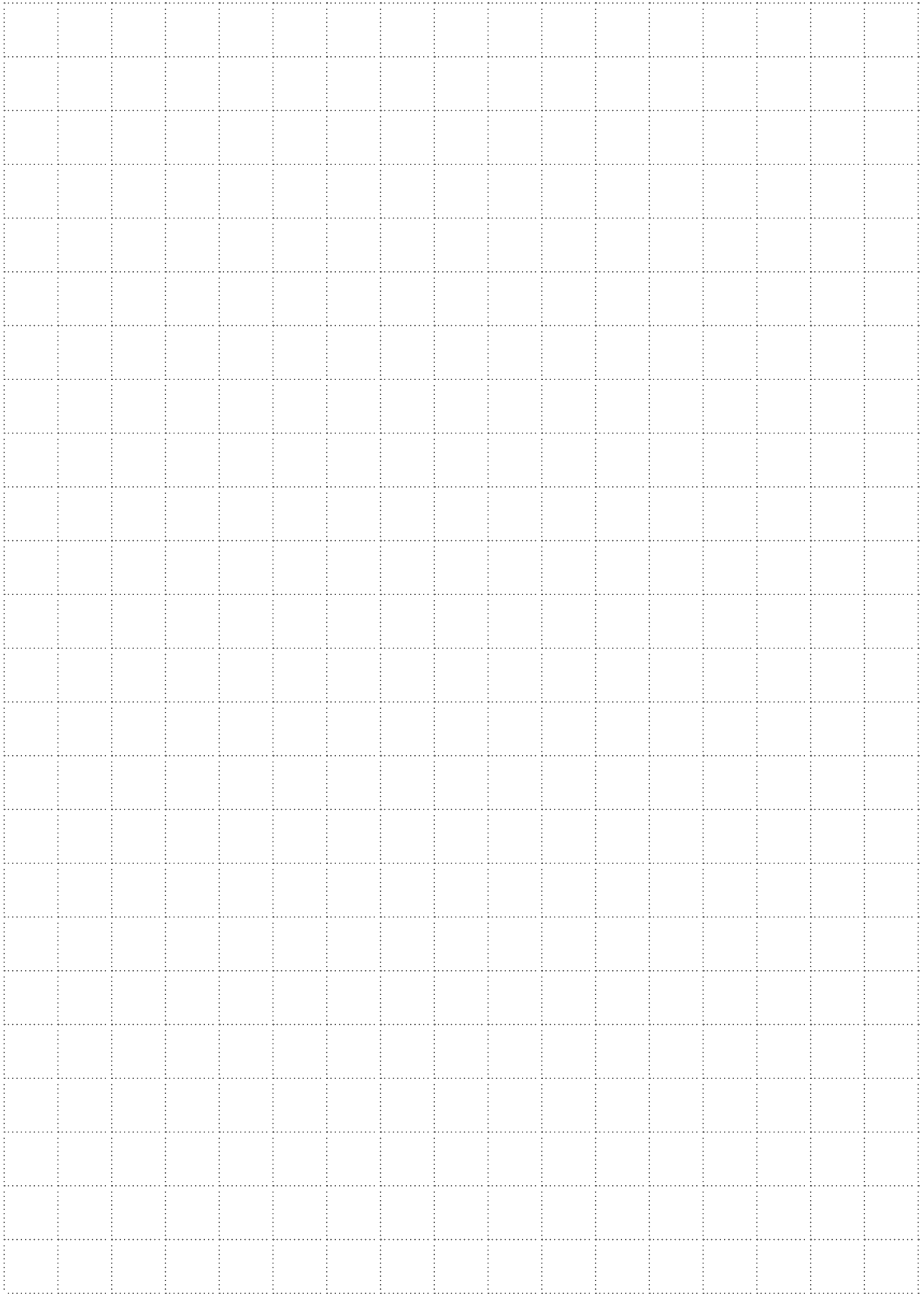

# Airwell

*As part of our ongoing product improvement programme, our products are subject to change without prior notice. Non contractual photos.*



CAC Export Department  
42 cours Jean-Jaurès  
17800 Pons - France  
Tel. : +33 (0)5 46 92 33 33 - Fax : +33 (0)5 46 91 26 44

Your distributor :