

► Fan Coil Units

Aqu@Fan II

*Innovative,
High Performance,
Quiet Units.*



Engineering Data Manual

EDM AQF-A.5GB

Date : May 2007

Supersedes : TM AQF-A.4GB/01.06

Airwell

Quality, efficiency and reliability, built into every unit...



Support feet supplied as optional

■ **Vertical console units with cabinet, AWC type**

AWC vertical console units are designed for use in three different types of installation :

- as a wall hung console in areas where a skirting board prevents the use of a floor mounted console ;
- as a floor console with optional front air intake RF (most frequently located below a large window) ;
- as a floor console with support feet and bottom air intake.

They feature a modern decorative style cabinet with matching plastic discharge grille, providing a high performance unit that is attractive and durable which will complement any room decor.

The AWC models can be fitted, as optional, with electromechanical or electronic Aqu@Net control, with valve kits, etc.

■ **Vertical concealed units without cabinet, AWN type**

AWN vertical chassis only units are designed for applications that require a fully concealed or a fully recessed installation.

These units include all the features of the AWC vertical console unit type except that only the chassis is supplied instead of decorative style cabinet.

Like the AWC units, Aqu@Net control (except the remote control) as well as other electromechanical controls and valve kits can be fitted, as optional, on unit.

Units can be fitted with optional feet (supplied loose), if floor mounting is required.



Bottom air intake grille supplied as optional

■ **Ceiling exposed units with cabinet, AHC type**

AHC ceiling exposed units are designed for ceiling mounting in areas where it is necessary to conserve floor space.

They contain all the features of the AWC unit within the decorative style cabinet with matching plastic discharge grille.

Standard version is designed for rear horizontal air intake without inlet grille.

Similar to the previous models, the Aqu@Net control can be supplied, as optional, on AHC units with remote control. Other optional controls and valve kits are also available.

■ **Ceiling concealed units without cabinet, AHN type**

AHN ceiling chassis units are designed for concealed or recessed ceiling installations. This unit consists of the AHC basic unit horizontally installed.

AHN units contain all the features of the AHC ceiling exposed units except that only the chassis casing is supplied instead of the decorative style cabinet.

Possibility of supplying separately an optional Aqu@Net type remote control for wall mounting. Other optional controls and valve kits are also available.



Auxiliary drain pan supplied as optional

New range of fan coil units Aqu@Fan II : "Innovation for an optimum comfort"

Easy to install, improvement in sound levels and performances, new Aqu@Net electronic control...

The new range of **Aqu@Fan II** fan coil units is issued from a development striving to meet customers' wishes and advices.

Aesthetic of the grille, associated with the casing refined finish allows a harmonious and smart integration of the fan coil units **Aqu@Fan II** in all types of interiors.

They are the ideal solution to air condition agreeably and efficiently, flats, hotels, hospitals, offices and other premises, all year long.

The Aqu@Fan II fan coil units range includes **9 sizes** with air flows ranging from **100 thru 1600 m³/h**, for cooling capacities of **1 thru 10 kW**.

The Aqu@Fan II fan coil units are equipped with optimized coils to bring the best possible performances in **2-pipe, 4-pipe, or 2-pipe/2-wire versions**.

■ Design features

Cabinet

All units are manufactured from heavy-gauge zinc coated sheet steel for long life and durability. Oven baked powder epoxy paint insures a good protection and an attractive finish for all outside panels. (Standard colour : **RAL 9003**).

The standard discharge grille is made of "ABS" plastic and has a different colour from the cabinet (standard colour : **Pantone 427C**).

On the versions with optional front intake, monobloc grille, painted in RAL 9003, is mounted flush to the cabinet. Grille can be removed by releasing the two quarter turn fixing screws to get access to the filter.

Casing

Made of galvanized steel insulated with closed cell polyethylene foam. Casing has 4 slotted lugs on its rear side which allow the unit to be easily and quickly installed at site, in wall or ceiling mounting.

Access to all internal components of the unit is facilitated by an easy dismantling of the casing.

Condensate drain pan is fabricated from galvanized sheet steel coated with closed cell polyethylene foam on external face. **The drain pan is painted** to insure the anticorrosion protection.

For the models AHC/AHN 10 to 90, a V-shape condensate drain pan is provided to ensure optimal condensate draining and to minimize water retention.

The models AWC/AWN/AHC/AHN 20 to 70 are also equipped with a **V-shape pan in order to allow indifferently the vertical or horizontal installation**.

Coils

Made of staggered copper tubes, mechanically expanded into high efficiency aluminium fins, assuring maximum heat transfer efficiency.

- On two pipe system, fan coil units are factory mounted with a 2 row main coil or optional 3 row coil supplying higher capacity ;
- On four pipe system, fan coil units can be factory mounted with a 2 or 3 row main coil plus 1 row auxiliary heating coil.

The 4-pipe and 2-pipe/2-wire coils are supplied in one finned block only for models 10, 80 and 90 and in **two separate coils** for models 20 to 70.

■ Model nomenclature

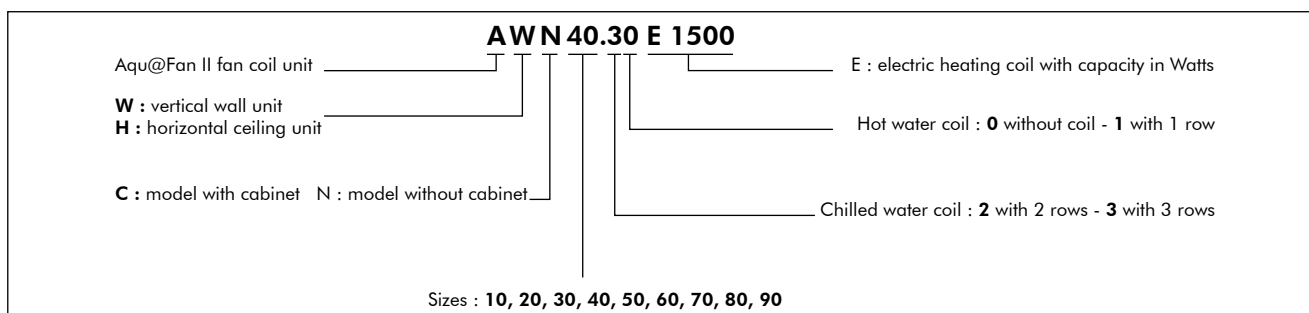

Moreover, the new technology of the fan motor assembly, through the use of optimized centrifugal impellers, associated with a **5-speed motor enables all Aqu@Fan II models to reach an average decrease in sound levels of - 4dBA**, compared with the previous range, offering therefore a maximum acoustical comfort.

Aqu@Fan II range is provided with a **new electronic control : Aqu@Net**, whose ergonomic and discrete remote command can be loose or fitted on the fan coil unit.

All settings being made at factory, no needs to be done by installer.

This control, especially innovating, **offers as standard a master/slave function up to 15 units** from one single remote control.

Other features like window contact, occupied/unoccupied, antifreeze modes are integrated without involving any price add.

Each coil is supplied with headers having air vent at the highest point and drain plug at the lowest point. The water connection of each header is 1/2"Ø female threaded type.

For the 2-pipe/2-wire systems, the electric heating coil is composed of heating **rod type resistances** mounted inside the coil (at the place of hot water tubes).

The electric resistances, supplied in kit form, will be **finned type resistances**.

Note : The water connection side is defined left-hand or right-hand when observer is looking at the unit from the discharge side.

Fan and motor assembly

The units are fitted with :

- centrifugal impellers, specially designed to provide low noise levels with optimum air volume ;
- **5-speed motor** with 3 factory wired standard speeds. Each motor is fitted with thermal protection of automatic reset type.

Power supply : 230 V ± 10 % / 1 Ph / 50 Hz.

Electrical connections

Units are supplied complete with internal electrical wiring terminating in a junction block protected by a cap or the cabinet.

Cabinet internal space allows installation of optional control systems supplied by manufacturer or others.

When the optional Aqu@Net control is fitted on the unit, the controller includes a junction block for 230 V / 1 Ph / 50 Hz power supply connection and incorporates, as standard, a cable clamp.

Filter

Easily removable cleanable filter having fire class M1 and G1 efficiency. Filter media is mounted on a galvanized steel frame.



Options and accessories

Many different options and accessories are available for all units : see pages 4,6 and 8. Controls are shown on pages 17 to 19.

Aqu@Fan II AWC models

Options and accessories

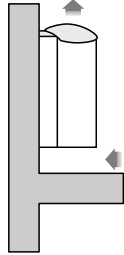
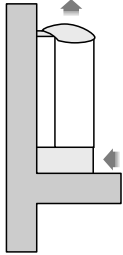
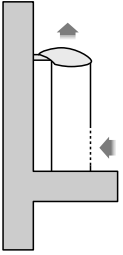
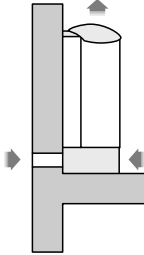
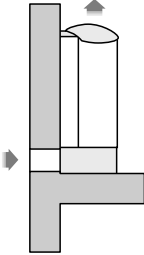
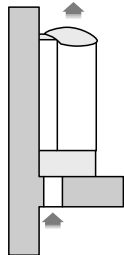
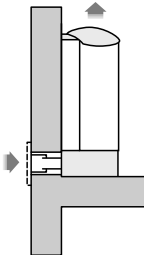
| | |
|----------------|---|
| STD | standard version for wall mounting (no support feet supplied). |
| MP | support feet for floor mounting. |
| MPG | air intake grille between feet. |
| RF | front air intake grille (no support feet supplied). |
| RP | back partial air intake with support feet. |
| RT | back full air intake with support feet. |
| RC | floor air intake with support feet. |
| RVCA-RT | air intake arrangement with motorized (non controlled) on/off damper (back or front intake). |
| RVCA-RC | air intake arrangement with motorized (non controlled) on/off damper (floor or front intake). |
| RVCM-RT | air intake arrangement with manual damper (back or/and front intake). |
| RVCM-RC | air intake arrangement with manual damper (floor or/and front intake). |
| TMT | telescopic wall sleeve. |
| TMTG | telescopic wall sleeve with external grille (filter not supplied). |
| RH | cabinet backwrap for plinth. |
| ALV | finished back panel (for unit mounted in front of glass wall). |
| BAC | auxiliary drain pan (for units without motorized valves). |
| FIX SOL | floor fixing brackets. |

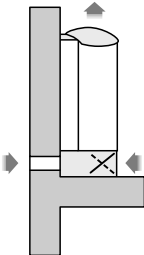
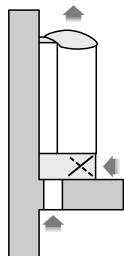
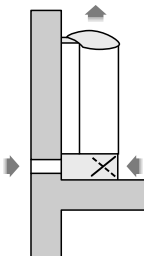
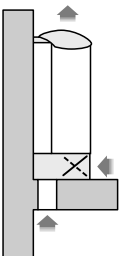
| <i>STD</i> | <i>MP/MPG</i> | <i>RF</i> | <i>RP *</i> | <i>RT</i> |
|---|---|--|---|---|
|  |  |  |  |  |
|  |  |  | |  |
|  |  | | |  |

* Can be fitted with optional intake grille between feet.

Dimensional Data - Aqu@Fan II AWC models

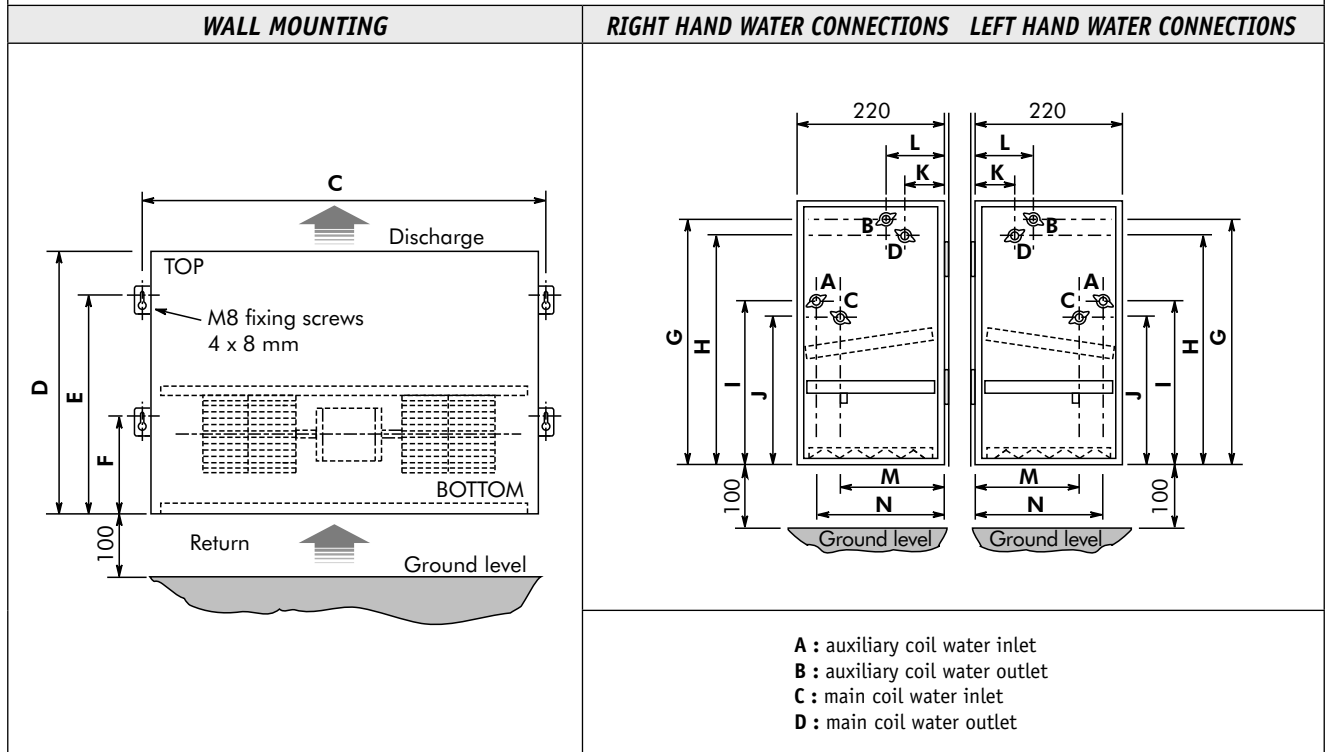
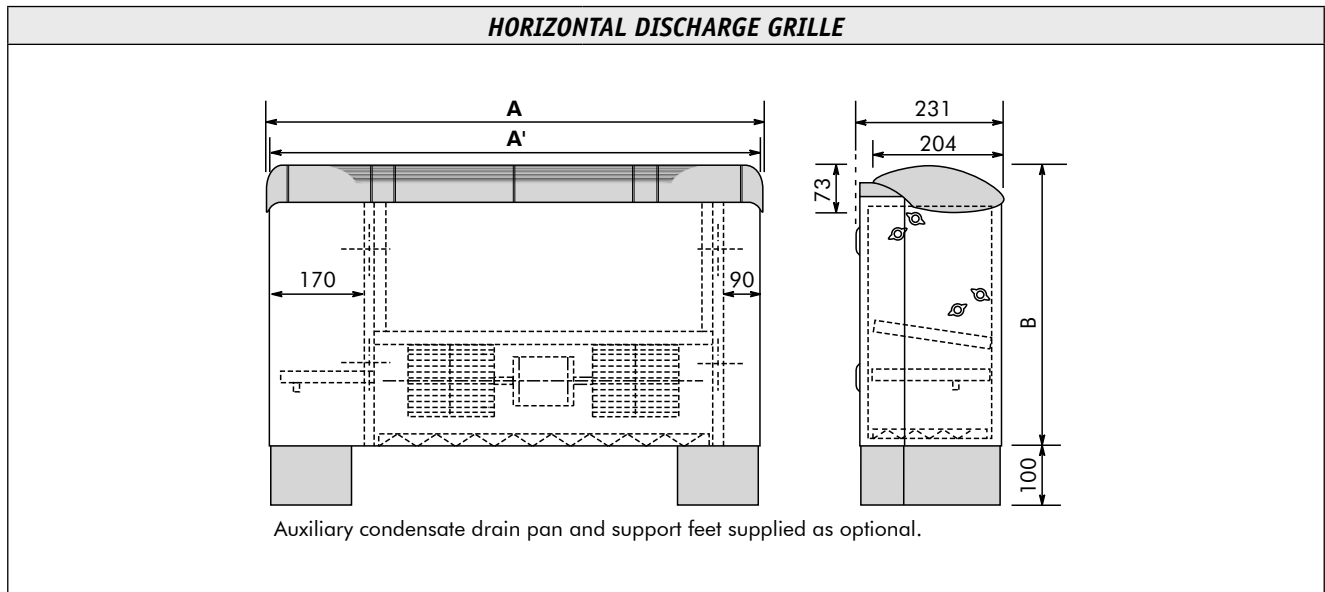

| Models | A | A' | B | C | D | E | F | G | H | I | J | K | L | M | N | Weight |
|--------|------|------|-----|------|-----|-----|-----|-----|-----|-----|-----|----|----|-----|-----|--------|
| 20 | 768 | 762 | 478 | 500 | 430 | 360 | 150 | 408 | 390 | 256 | 236 | 52 | 95 | 141 | 183 | 20 |
| 30 | 953 | 947 | 478 | 685 | 430 | 360 | 150 | 408 | 390 | 256 | 236 | 52 | 95 | 141 | 183 | 23 |
| 40 | 1138 | 1132 | 478 | 870 | 430 | 360 | 150 | 408 | 390 | 256 | 236 | 52 | 95 | 141 | 183 | 30 |
| 50 | 1323 | 1317 | 478 | 1055 | 430 | 360 | 150 | 408 | 390 | 256 | 236 | 52 | 95 | 141 | 183 | 35 |
| 60 | 1508 | 1502 | 478 | 1240 | 430 | 360 | 150 | 408 | 390 | 256 | 236 | 52 | 95 | 141 | 183 | 39 |
| 70 | 1323 | 1317 | 497 | 1055 | 530 | 365 | 157 | 506 | 492 | 289 | 233 | 41 | 88 | 145 | 172 | 42 |
| 80 | 1508 | 1502 | 578 | 1240 | 530 | 365 | 157 | 500 | 489 | 245 | 234 | 40 | 83 | 143 | 186 | 50 |
| 90 | 1693 | 1687 | 578 | 1425 | 530 | 365 | 157 | 500 | 489 | 245 | 234 | 40 | 83 | 143 | 186 | 56 |

Dimensions are in millimeters ; weight in kilograms.

Aqu@Fan II AWN models

Options and accessories

| | |
|----------------|---|
| STD | standard version for wall mounting (no support feet supplied). |
| MP | support feet for floor mounting. |
| RD | front air intake. |
| RP | back partial air intake with support feet. |
| RT | back full air intake with support feet. |
| RC | floor air intake with support feet. |
| RVCA-RT | air intake arrangement with motorized (non controlled) on/off damper (back or front intake). |
| RVCA-RC | air intake arrangement with motorized (non controlled) on/off damper (floor or front intake). |
| RVCM-RT | air intake arrangement with manual damper (back or/and front intake). |
| RVCM-RC | air intake arrangement with manual damper (floor or/and front intake). |
| TMT | telescopic wall sleeve. |
| TMTG | telescopic wall sleeve with external grille (filter not supplied). |
| BAC | auxiliary drain pan (for units without motorized valves). |
| CRG | discharge duct collar. |

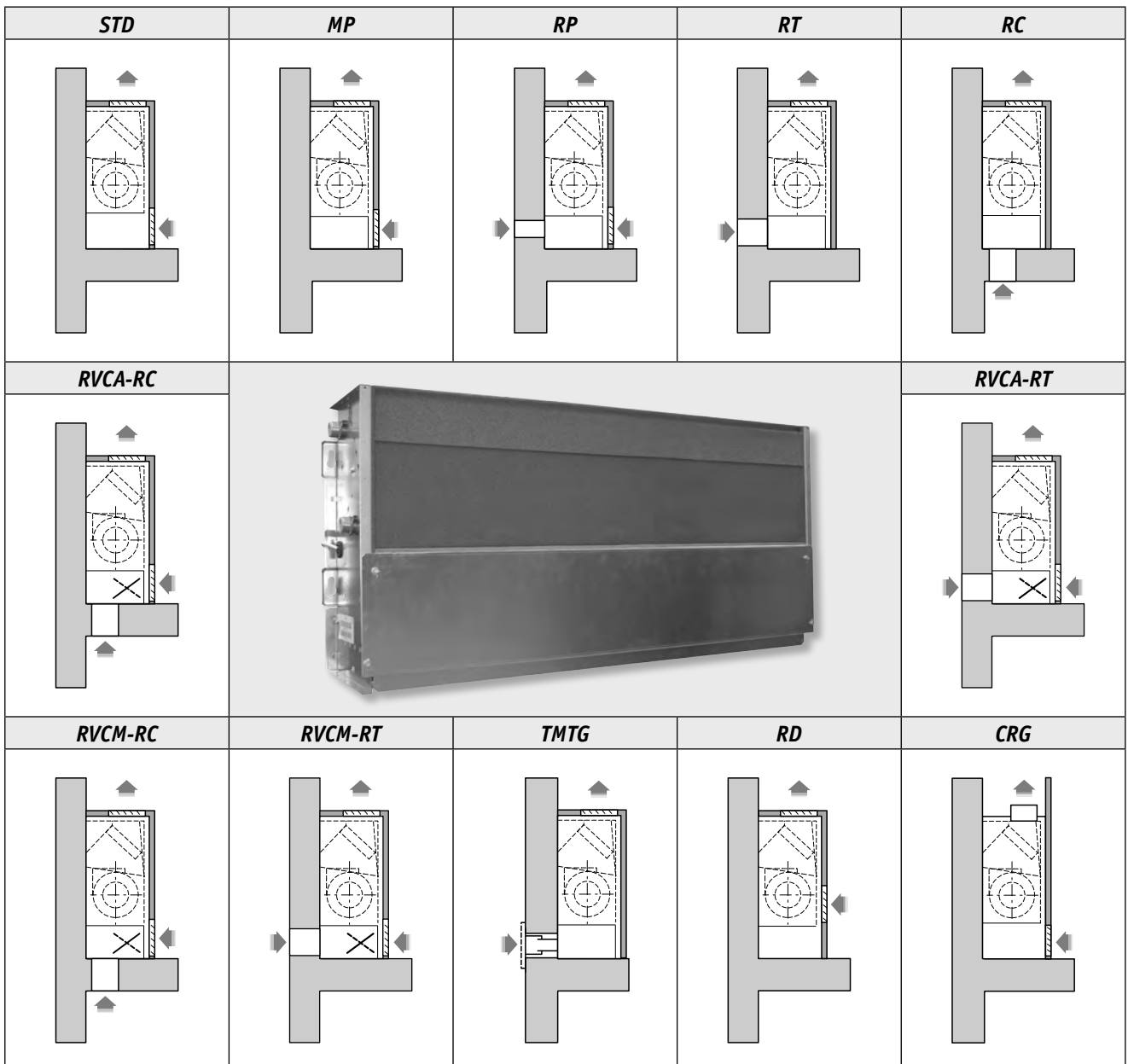

Dimensional data - Aqu@Fan II AWN models

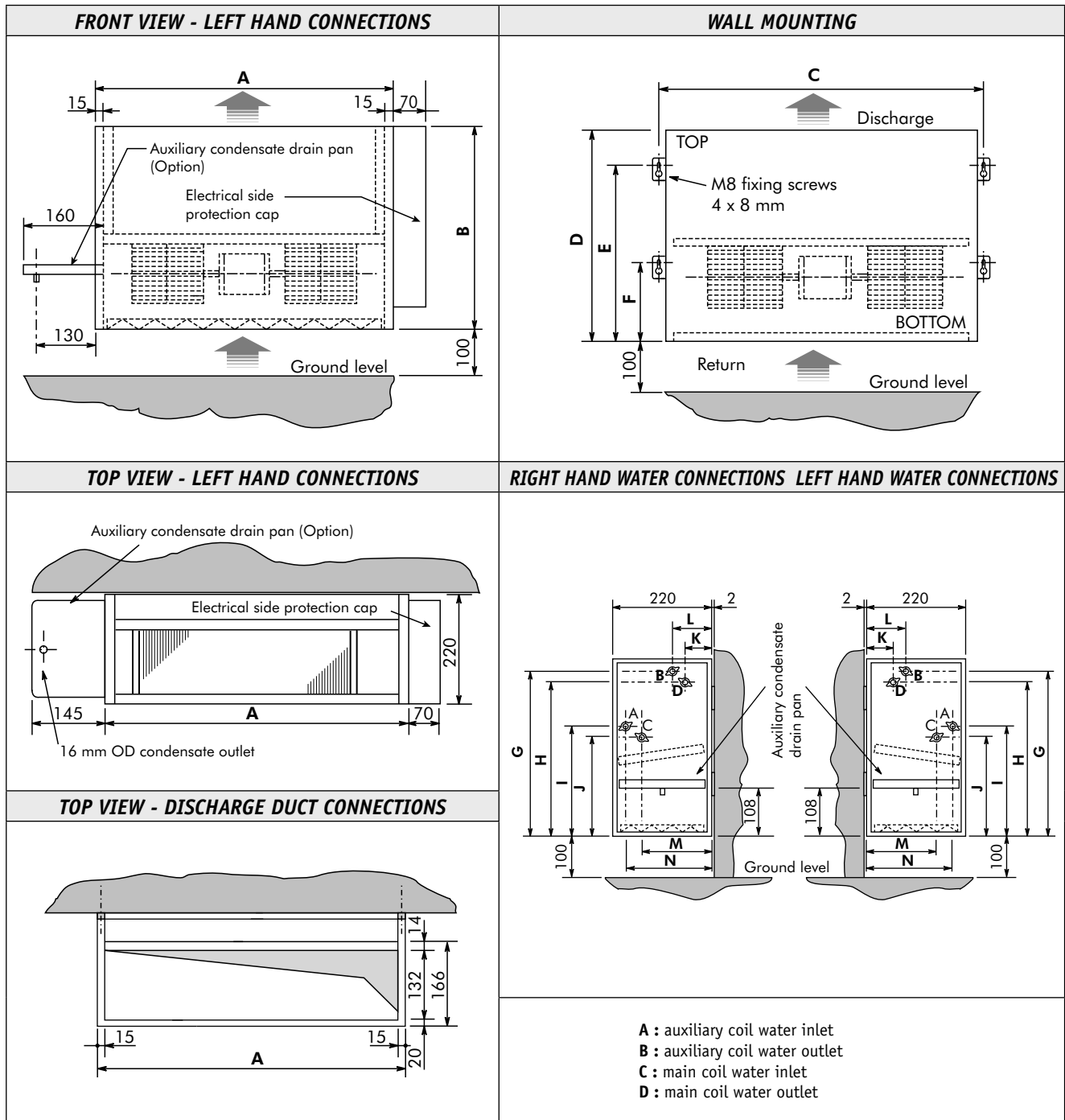

| Models | A | B | C | D | E | F | G | H | I | J | K | L | M | N | Weight |
|--------|------|-----|------|-----|-----|-----|-----|-----|-----|-----|----|----|-----|-----|--------|
| 10 | 370 | 430 | 360 | 430 | 360 | 150 | 406 | 390 | 255 | 238 | 54 | 95 | 141 | 182 | 11 |
| 20 | 510 | 430 | 500 | 430 | 360 | 150 | 408 | 390 | 256 | 236 | 52 | 95 | 141 | 183 | 14 |
| 30 | 695 | 430 | 685 | 430 | 360 | 150 | 408 | 390 | 256 | 236 | 52 | 95 | 141 | 183 | 16 |
| 40 | 880 | 430 | 870 | 430 | 360 | 150 | 408 | 390 | 256 | 236 | 52 | 95 | 141 | 183 | 23 |
| 50 | 1065 | 430 | 1055 | 430 | 360 | 150 | 408 | 390 | 256 | 236 | 52 | 95 | 141 | 183 | 27 |
| 60 | 1250 | 430 | 1240 | 430 | 360 | 150 | 408 | 390 | 256 | 236 | 52 | 95 | 141 | 183 | 30 |
| 70 | 1065 | 530 | 1055 | 530 | 365 | 157 | 506 | 492 | 289 | 233 | 41 | 88 | 145 | 172 | 34 |
| 80 | 1250 | 530 | 1240 | 530 | 365 | 157 | 500 | 489 | 245 | 234 | 40 | 83 | 143 | 186 | 41 |
| 90 | 1435 | 530 | 1425 | 530 | 365 | 157 | 500 | 489 | 245 | 234 | 40 | 83 | 143 | 186 | 46 |

Dimensions are in millimeters ; weight in kilograms.

Aqu@Fan II AHC models

Options and accessories

| | |
|----------------|--|
| STD | standard ceiling mounted version with rear air intake (no inlet grille). |
| RF | bottom air intake grille. |
| RVCA-RC | air intake arrangement with motorized (non controlled) on/off damper. |
| RVCM-RC | air intake arrangement with manual damper. |
| RC | rear air intake with support feet. |
| MP | support feet. |
| MPG | air intake grille between feet. |
| THI | return air perforated panel with filter media. |
| TMT | telescopic wall sleeve. |
| TMTG | telescopic wall sleeve with external grille (filter not supplied). |
| BAC | auxiliary painted drain pan (for units without motorized valves). |

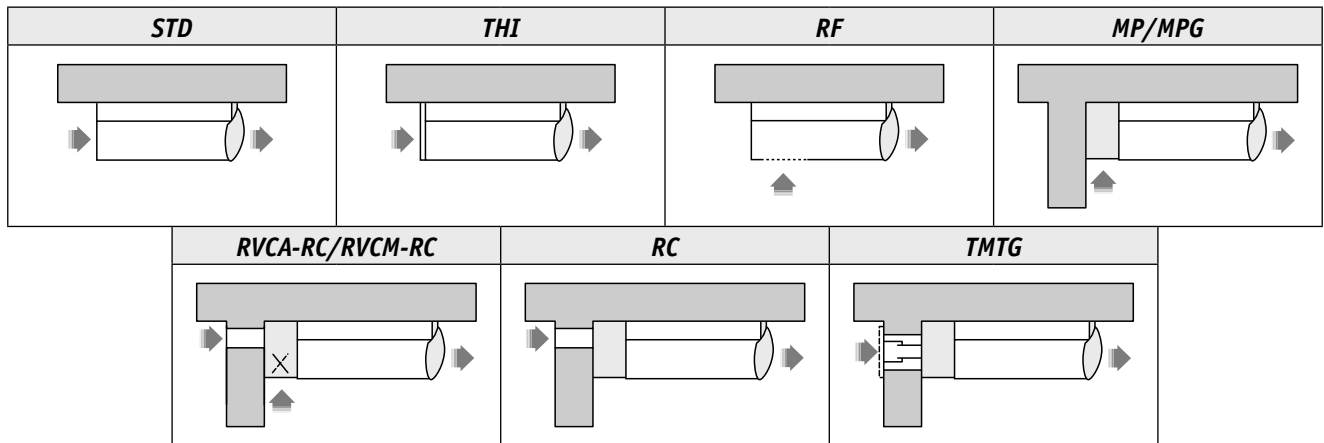

Aqu@Fan II AHN models

Options and accessories

| | |
|----------------|--|
| STD | standard ceiling mounted version with rear air intake (no inlet grille). |
| RVCA-RC | air intake arrangement with motorized (non controlled) on/off damper. |
| RVCM-RC | air intake arrangement with manual damper. |
| RC | rear air intake with support feet. |
| CRG | discharge duct collar. |
| TMT | telescopic wall sleeve. |
| TMTG | telescopic wall sleeve with external grille (filter not supplied). |
| BAC | auxiliary painted drain pan (for units without motorized valves). |

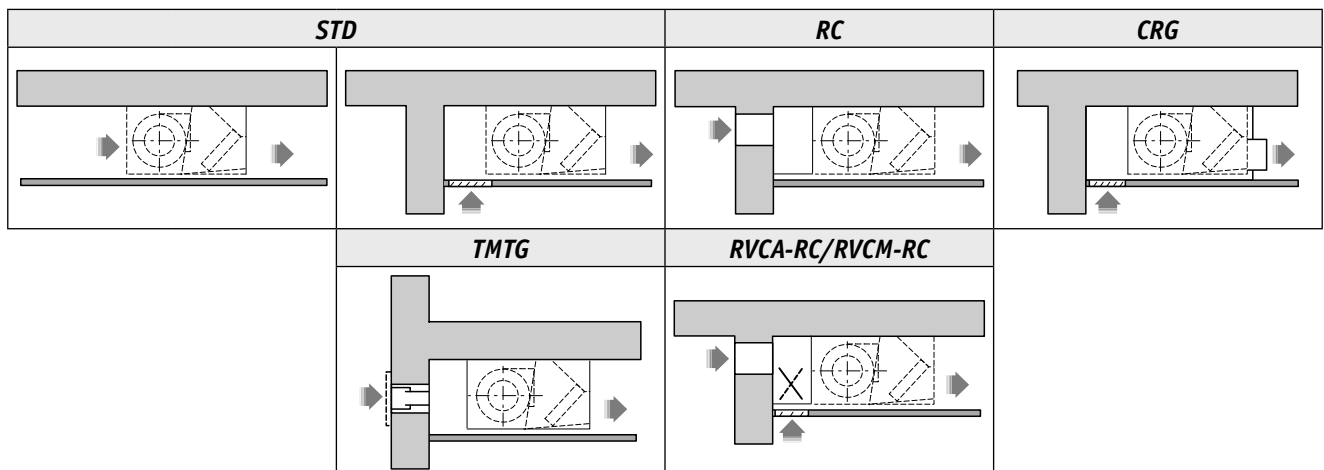

Dimensional data - Aqu@Fan II AHC models

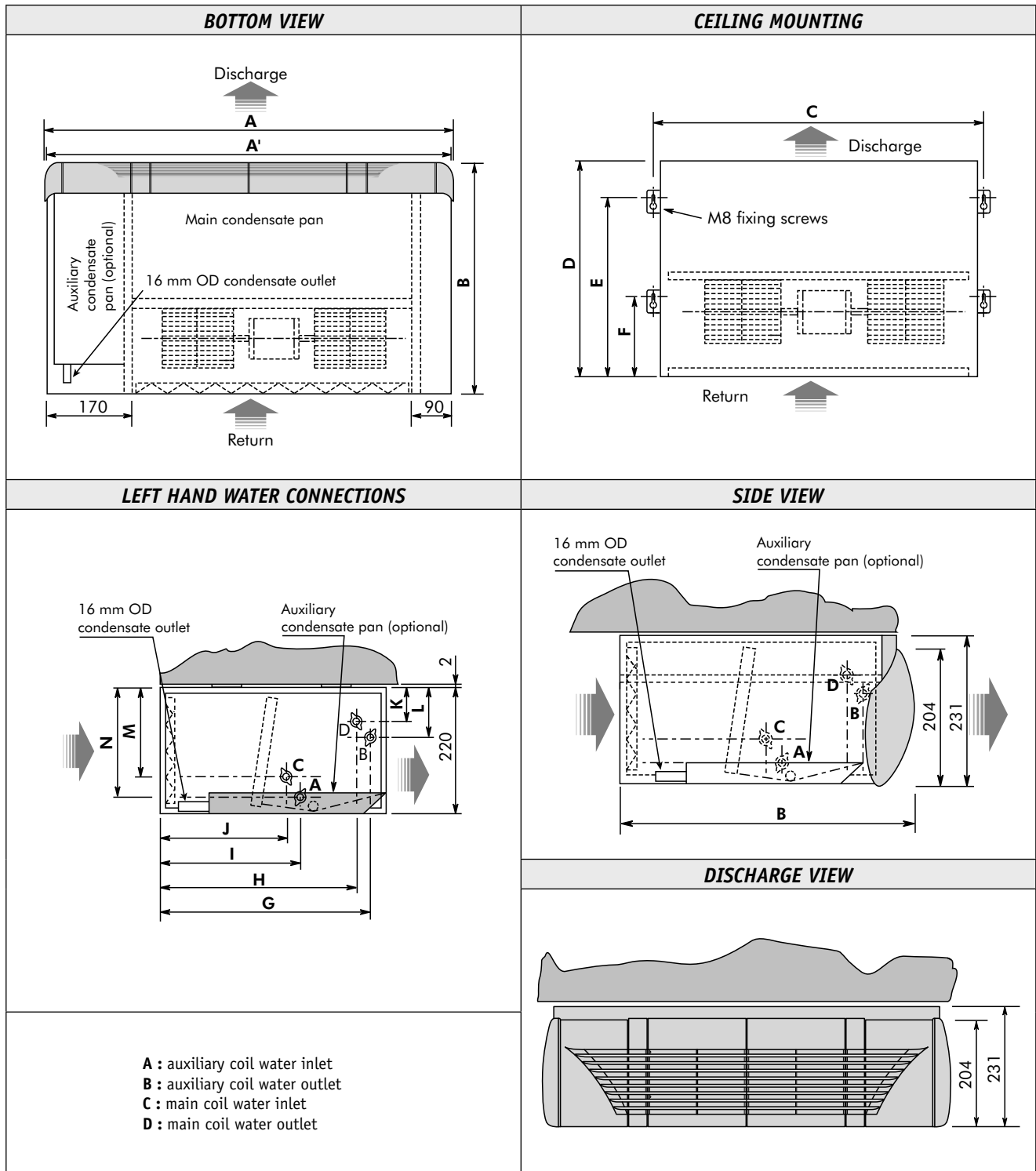

| Models | A | A' | B | C | D | E | F | G | H | I | J | K | L | M | N | Weight |
|--------|------|------|-----|------|-----|-----|-----|-----|-----|-----|-----|----|----|-----|-----|--------|
| 20 | 768 | 762 | 478 | 500 | 430 | 360 | 150 | 408 | 390 | 256 | 236 | 52 | 95 | 141 | 183 | 20 |
| 30 | 953 | 947 | 478 | 685 | 430 | 360 | 150 | 408 | 390 | 256 | 236 | 52 | 95 | 141 | 183 | 23 |
| 40 | 1138 | 1132 | 478 | 870 | 430 | 360 | 150 | 408 | 390 | 256 | 236 | 52 | 95 | 141 | 183 | 30 |
| 50 | 1323 | 1317 | 478 | 1055 | 430 | 360 | 150 | 408 | 390 | 256 | 236 | 52 | 95 | 141 | 183 | 35 |
| 60 | 1508 | 1502 | 478 | 1240 | 430 | 360 | 150 | 408 | 390 | 256 | 236 | 52 | 95 | 141 | 183 | 39 |
| 70 | 1323 | 1317 | 497 | 1055 | 530 | 365 | 157 | 506 | 492 | 289 | 233 | 41 | 88 | 145 | 172 | 42 |
| 80 | 1508 | 1502 | 578 | 1240 | 530 | 365 | 157 | 500 | 489 | 245 | 234 | 40 | 83 | 143 | 186 | 50 |
| 90 | 1693 | 1687 | 578 | 1425 | 530 | 365 | 157 | 500 | 489 | 245 | 234 | 40 | 83 | 143 | 186 | 56 |

Dimensions are in millimeters ; weight in kilograms.

Dimensional data - Aqu@Fan II AHN models

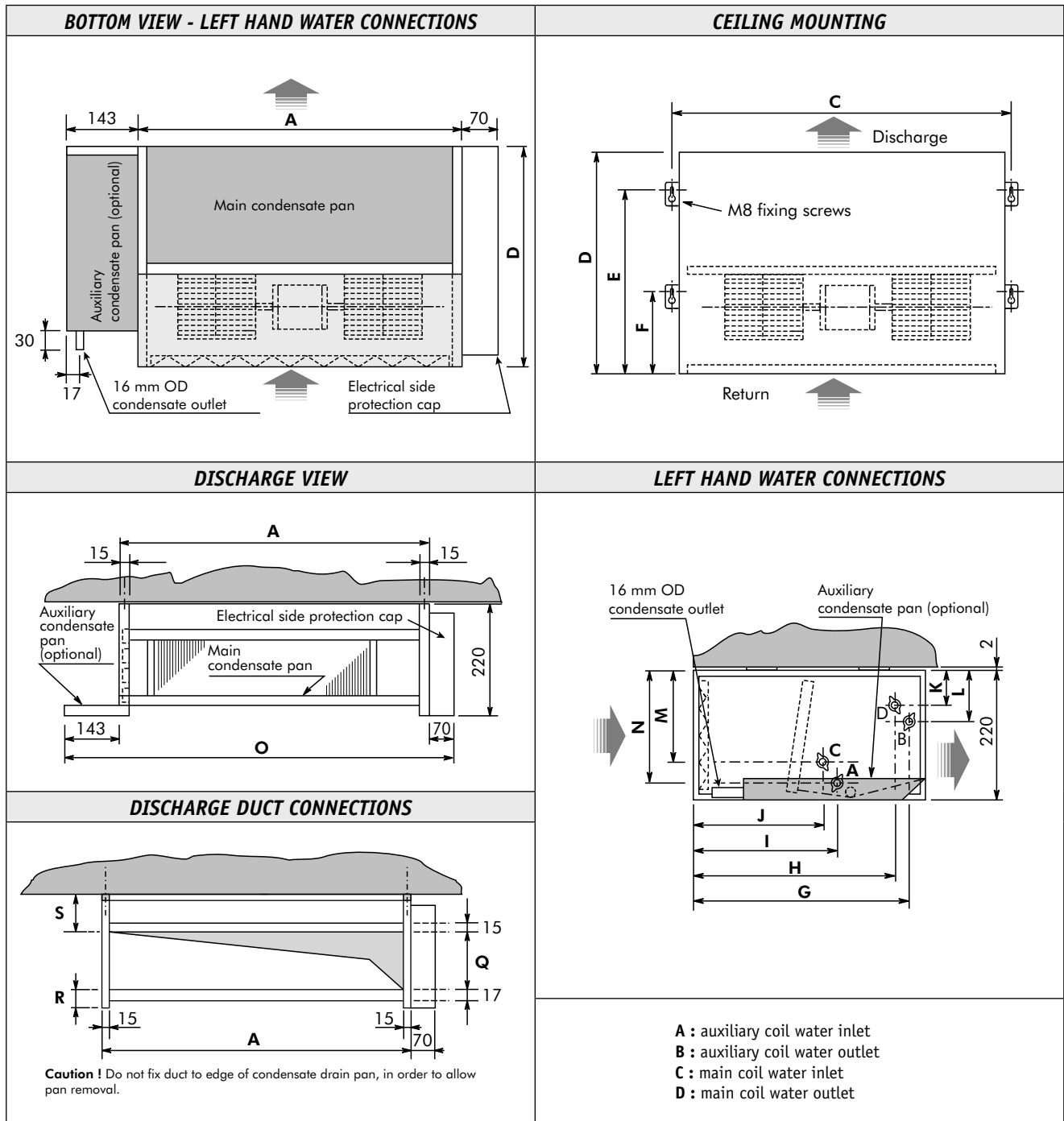

| Models | A | C | D | E | F | G | H | I | J | K | L | M | N | O | Q | R | S | Weight |
|--------|------|------|-----|-----|-----|-----|-----|-----|-----|----|----|-----|-----|------|-----|----|----|--------|
| 10 | 370 | 360 | 430 | 360 | 150 | 406 | 390 | 255 | 238 | 54 | 95 | 141 | 182 | 583 | 122 | 30 | 68 | 11 |
| 20 | 510 | 500 | 430 | 360 | 150 | 408 | 390 | 256 | 236 | 52 | 95 | 141 | 183 | 723 | 122 | 30 | 68 | 14 |
| 30 | 695 | 685 | 430 | 360 | 150 | 408 | 390 | 256 | 236 | 52 | 95 | 141 | 183 | 908 | 122 | 30 | 68 | 16 |
| 40 | 880 | 870 | 430 | 360 | 150 | 408 | 390 | 256 | 236 | 52 | 95 | 141 | 183 | 1093 | 122 | 30 | 68 | 23 |
| 50 | 1065 | 1055 | 430 | 360 | 150 | 408 | 390 | 256 | 236 | 52 | 95 | 141 | 183 | 1278 | 122 | 30 | 68 | 27 |
| 60 | 1250 | 1240 | 430 | 360 | 150 | 408 | 390 | 256 | 236 | 52 | 95 | 141 | 183 | 1463 | 122 | 30 | 68 | 30 |
| 70 | 1065 | 1055 | 530 | 365 | 157 | 506 | 492 | 289 | 233 | 41 | 88 | 145 | 172 | 1278 | 123 | 32 | 65 | 34 |
| 80 | 1250 | 1240 | 530 | 365 | 157 | 500 | 489 | 245 | 234 | 40 | 83 | 143 | 186 | 1463 | 123 | 32 | 65 | 41 |
| 90 | 1435 | 1425 | 530 | 365 | 157 | 500 | 489 | 245 | 234 | 40 | 83 | 143 | 186 | 1648 | 123 | 32 | 65 | 46 |

Dimensions are in millimeters ; weight in kilograms.

Aqu@Fan II - Available options

Coils

| | | AWC | AWN | AHC | AHN |
|-------|---|-----|-----|-----|-----|
| XX20 | 2 row main coil - 2 pipe system | Yes | Yes | Yes | Yes |
| XX30 | 3 row main coil - 2 pipe system | Yes | Yes | Yes | Yes |
| XX21 | 2 row main coil + 1-row additional coil - 4 pipe system | Yes | Yes | Yes | Yes |
| XX31 | 3 row main coil + 1-row additional coil - 4 pipe system | Yes | Yes | Yes | Yes |
| XX20E | 2 row main coil + standard electric heating coil - 2 pipe / 2 wire system | Yes | Yes | Yes | Yes |
| XX30E | 3 row main coil + standard electric heating coil - 2 pipe / 2 wire system | Yes | Yes | Yes | Yes |

Note : XX = size of unit (for example : 1020 = fan coil size 10 with 2-row main coil - 2 pipe system).

2-way control valve - 2-pipe system - 230-Volt (or optional 24-Volt) thermal actuator

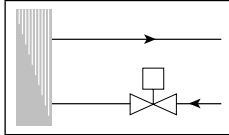

| W2G1 | 1 valve, 2-way type - For 2-pipe system on cooling or heating coil | | | | | | |
|-------|--|------|-----------------------------------|-------------|--------|--------|--------|
| | Valve | | Thermal actuator 230 V - 50/60 Hz | | | | |
| Sizes | KV | Ø | T max amb | T max fluid | Id (A) | In (A) | P (VA) |
| 10/60 | 1.6 | 1/2" | 50 °C | 110 °C | 0.6 | 0.013 | 3.0 |
| 70/90 | 2.5 | 3/4" | 50 °C | 110 °C | 0.6 | 0.013 | 3.0 |

2-way control valve - 4-pipe system - 230-Volt (or optional 24-Volt) thermal actuator

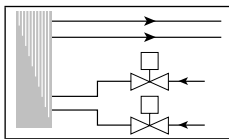
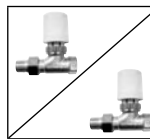

| W2G2 | 2 valves, 2-way type - For 4-pipe system on cooling and heating coils | | | | | | | |
|-------|---|------|---------------|------|--------------------------------------|-------------|--------|--------|
| | Cooling valve | | Heating valve | | Thermal actuator(s) 230 V - 50/60 Hz | | | |
| Sizes | KV | Ø | KV | Ø | T max amb | T max fluid | Id (A) | P (VA) |
| 10/60 | 1.6 | 1/2" | 1.6 | 1/2" | 50 °C | 110 °C | 0.6 | 0.013 |
| 70/90 | 2.5 | 3/4" | 1.6 | 1/2" | 50 °C | 110 °C | 0.6 | 0.013 |

4-way control valve - 2-pipe system - 230-Volt (or optional 24-Volt) thermal actuator

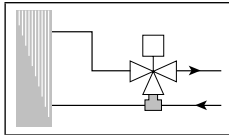

| W4G1 | 1 valve, 4-way type - For 2-pipe system on cooling or heating coil | | | | | | |
|-------|--|------|-----------------------------------|-------------|--------|--------|--------|
| | Valve | | Thermal actuator 230 V - 50/60 Hz | | | | |
| Sizes | KV | Ø | T max amb | T max fluid | Id (A) | In (A) | P (VA) |
| 10/60 | 1.6 | 1/2" | 50 °C | 110 °C | 0.6 | 0.013 | 3.0 |
| 70/90 | 2.5 | 3/4" | 50 °C | 110 °C | 0.6 | 0.013 | 3.0 |

4-way control valve - 4-pipe system - 230-Volt (or optional 24-Volt) thermal actuator

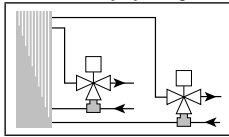
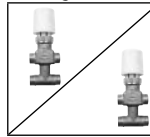

| W4G2 | 2 valves, 4-way type - For 4-pipe system on cooling and heating coils | | | | | | | |
|-------|---|------|---------------|------|--------------------------------------|-------------|--------|--------|
| | Cooling valve | | Heating valve | | Thermal actuator(s) 230 V - 50/60 Hz | | | |
| Sizes | KV | Ø | KV | Ø | T max amb | T max fluid | Id (A) | P (VA) |
| 10/60 | 1.6 | 1/2" | 1.6 | 1/2" | 50 °C | 110 °C | 0.6 | 0.013 |
| 70/90 | 2.5 | 3/4" | 1.6 | 1/2" | 50 °C | 110 °C | 0.6 | 0.013 |

2-way control valve - 2-pipe system - 3-point modulating actuator*

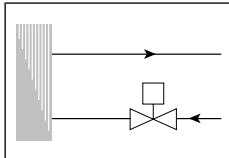

| W2G1 | 1 valve, 2-way type - For 2-pipe system on cooling or heating coil | | | | |
|-------|--|------|------------------------------|-------------|--------|
| | Valve | | 24-Volts actuator - 50/60 Hz | | |
| Sizes | KV | Ø | T max amb | T max fluid | P (VA) |
| 10/20 | 0.6 | 1/2" | 60 °C | 110 °C | 7.0 |
| 30/60 | 1.6 | 1/2" | 60 °C | 110 °C | 7.0 |
| 70/90 | 2.5 | 3/4" | 60 °C | 110 °C | 7.0 |

2-way control valve - 4-pipe system - 3-point modulating actuator*

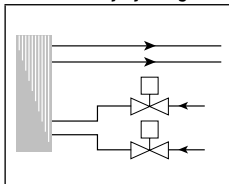

| W2G2 | 2 valves, 2-way type - For 4-pipe system on cooling and heating coils | | | | | | |
|-------|---|------|---------------|------|------------------------------|-------------|--------|
| | Cooling valve | | Heating valve | | 24-Volts actuator - 50/60 Hz | | |
| Sizes | KV | Ø | KV | Ø | T max amb | T max fluid | P (VA) |
| 10/20 | 0.6 | 1/2" | 0.6 | 1/2" | 60 °C | 110 °C | 7.0 |
| 30/40 | 1.6 | 1/2" | 0.6 | 1/2" | 60 °C | 110 °C | 7.0 |
| 50/60 | 1.6 | 1/2" | 1.6 | 1/2" | 60 °C | 110 °C | 7.0 |
| 70/90 | 2.5 | 3/4" | 1.6 | 1/2" | 60 °C | 110 °C | 7.0 |

4-way control valve - 2-pipe system - 3-point modulating actuator*

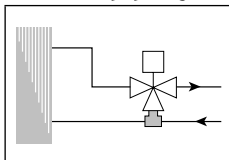

| W4G1 | 1 valve, 4-way type - For 2-pipe system on cooling or heating coil | | | | |
|-------|--|------|------------------------------|-------------|--------|
| | Valve | | 24-Volts actuator - 50/60 Hz | | |
| Sizes | KV | Ø | T max amb | T max fluid | P (VA) |
| 10/20 | 0.6 | 1/2" | 60 °C | 110 °C | 7.0 |
| 30/60 | 1.6 | 1/2" | 60 °C | 110 °C | 7.0 |
| 70/90 | 2.5 | 3/4" | 60 °C | 110 °C | 7.0 |

4-way control valve - 4-pipe system - 3-point modulating actuator*

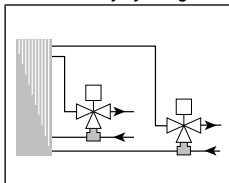

| W4G2 | 2 valves, 4-way type - For 4-pipe system on cooling and heating coils | | | | | | |
|-------|---|------|---------------|------|------------------------------|-------------|--------|
| | Cooling valve | | Heating valve | | 24-Volts actuator - 50/60 Hz | | |
| Sizes | KV | Ø | KV | Ø | T max amb | T max fluid | P (VA) |
| 10/20 | 0.6 | 1/2" | 0.6 | 1/2" | 60 °C | 110 °C | 7.0 |
| 30/40 | 1.6 | 1/2" | 0.6 | 1/2" | 60 °C | 110 °C | 7.0 |
| 50/60 | 1.6 | 1/2" | 1.6 | 1/2" | 60 °C | 110 °C | 7.0 |
| 70/90 | 2.5 | 3/4" | 1.6 | 1/2" | 60 °C | 110 °C | 7.0 |

(*) Actuator available with Honeywell or similar digital controllers (consult factory).

Aqu@Fan II - Optional electric heating coils

■ Electric heaters with heating rods (supplied fitted)

| | BE1 | BE2 | BE3 | BE4 |
|----|------|------|------------------------------------|------------------------------------|
| 10 | 200 | 400 | 600 ⁽¹⁾ (200+400) | NA |
| 20 | 300 | 600 | 900 ⁽¹⁾ (300+600) | NA |
| 30 | 300 | 600 | 900 ⁽¹⁾ (300+600) | 1200 ⁽¹⁾ (600+600) |
| 40 | 500 | 1000 | 1500 ⁽¹⁾ (500+1000) | 2000 ⁽¹⁾ (1000+1000) |
| 50 | 600 | 1200 | 1800 ⁽¹⁾ (600+1200) | 2400 ⁽¹⁾ (1200+1200) |
| 60 | 750 | 1500 | 2250 ⁽¹⁾ (750+1500) | 3000 ⁽¹⁾ (1500+1500) |
| 70 | 750 | 1500 | 2250 ⁽¹⁾ (750+1500) | 3000 ⁽¹⁾ (1500+1500) |
| 80 | 900 | 1800 | 2700 ⁽¹⁾ (900+1800) | 3600 ⁽¹⁾ (1800+1800) |
| 90 | 1000 | 2000 | 3000 ⁽¹⁾ (1000+2000) | 4000 ⁽¹⁾ (2000+2000) |

(1) Available in 2 steps suitable for Aqu@Net control.

NA : Not available.

■ Electric heaters with finned resistances (supplied loose)

| | BE1 | BE2 | BE3 | BE4 | BE5 |
|----|-----|------|---------------------|---------------------|---------------------------|
| 10 | 250 | 500 | 750 ⁽¹⁾ | NA | NA |
| 20 | 375 | 750 | 1125 ⁽¹⁾ | NA | NA |
| 30 | 600 | 1200 | 1800 ⁽¹⁾ | NA | NA |
| 40 | 750 | 1500 | 2250 ⁽¹⁾ | NA | NA |
| 50 | 500 | 1000 | 1500 ⁽¹⁾ | 2000 ⁽¹⁾ | 3000 ⁽¹⁾ |
| 60 | 600 | 1200 | 1800 ⁽¹⁾ | 2400 ⁽¹⁾ | 3600 ^(2&3) |
| 70 | 500 | 1000 | 1500 ⁽¹⁾ | 2000 ⁽¹⁾ | 3000 ⁽¹⁾ |
| 80 | 600 | 1200 | 1800 ⁽¹⁾ | 2400 ⁽¹⁾ | 3600 ^(2&3) |
| 90 | 750 | 1500 | 2250 ⁽¹⁾ | 3000 ⁽¹⁾ | 4500 ^(2&3) |

(1) Available in 2 steps suitable for Aqu@Net control.

(2) Suitable only for 3-phase (400 V + Neutral) power supply and provided with relay(s).

(3) Aqu@Net control is not available with this capacity.

NA : Not available.

Aqu@Fan II performance data - 2-pipe system

■ 2-row main coil

| Sizes | Speeds | Air flow (m ³ /h) | Cooling | | | | Heating | | | Lw global (dBA) | Lp global (dBA) | NR/ISO |
|-------|--------|---------------------------------|-----------|-----------|---------------------|--------------|-----------|---------------------|--------------|-----------------------|-----------------------|--------|
| | | | Pt (W) | Ps (W) | Water flow (l/h) | WPD (kPa) | Pc (W) | Water flow (l/h) | WPD (kPa) | | | |
| 1020 | V1 | 175 | 990 | 792 | 169 | 10 | 1459 | 169 | 8 | 48 | 40 | 35 |
| | V2 | 155 | 928 | 737 | 158 | 9 | 1339 | 158 | 7 | 45 | 37 | 33 |
| | V3 | 132 | 836 | 660 | 144 | 7 | 1184 | 144 | 6 | 41 | 33 | 28 |
| | V4 | 113 | 726 | 568 | 126 | 6 | 1039 | 126 | 5 | 37 | 29 | 24 |
| | V5 | 95 | 623 | 480 | 108 | 4 | 870 | 108 | 4 | 32 | 24 | 18 |
| 2020 | V1 | 307 | 1731 | 1401 | 299 | 30 | 2378 | 299 | 27 | 53 | 45 | 41 |
| | V2 | 273 | 1600 | 1270 | 274 | 26 | 2256 | 273 | 23 | 49 | 41 | 37 |
| | V3 | 216 | 1350 | 1050 | 230 | 19 | 1943 | 230 | 17 | 42 | 34 | 29 |
| | V4 | 172 | 1151 | 870 | 198 | 14 | 1607 | 198 | 13 | 35 | 27 | 23 |
| | V5 | 141 | 970 | 723 | 166 | 11 | 1217 | 165 | 9 | 33 | 25 | 20 |
| 3020 | V1 | 394 | 2100 | 1790 | 360 | 8 | 2996 | 360 | 7 | 55 | 47 | 43 |
| | V2 | 339 | 2023 | 1657 | 346 | 8 | 2692 | 349 | 6 | 51 | 43 | 39 |
| | V3 | 281 | 1864 | 1441 | 320 | 7 | 2394 | 321 | 5 | 47 | 39 | 34 |
| | V4 | 245 | 1720 | 1280 | 295 | 6 | 2098 | 295 | 5 | 43 | 35 | 29 |
| | V5 | 176 | 1365 | 937 | 234 | 4 | 1712 | 234 | 3 | 36 | 28 | 22 |
| 4020 | V1 | 552 | 3010 | 2600 | 515 | 18 | 3906 | 515 | 15 | 51 | 43 | 38 |
| | V2 | 455 | 2650 | 2180 | 454 | 14 | 3637 | 453 | 12 | 47 | 39 | 35 |
| | V3 | 373 | 2249 | 1839 | 385 | 11 | 3099 | 386 | 9 | 41 | 33 | 28 |
| | V4 | 340 | 2128 | 1708 | 364 | 10 | 2899 | 364 | 8 | 39 | 31 | 26 |
| | V5 | 286 | 1910 | 1497 | 328 | 8 | 2542 | 328 | 7 | 36 | 28 | 23 |
| 5020 | V1 | 713 | 4360 | 3440 | 749 | 37 | 5346 | 749 | 32 | 55 | 47 | 43 |
| | V2 | 536 | 3255 | 2540 | 558 | 22 | 4317 | 558 | 19 | 48 | 40 | 37 |
| | V3 | 456 | 2919 | 2219 | 501 | 18 | 3844 | 501 | 15 | 44 | 36 | 32 |
| | V4 | 348 | 2350 | 1770 | 403 | 12 | 3198 | 403 | 10 | 38 | 30 | 25 |
| | V5 | 323 | 2210 | 1650 | 378 | 11 | 3038 | 378 | 9 | 36 | 28 | 22 |
| 6020 | V1 | 888 | 4910 | 3340 | 843 | 29 | 6407 | 842 | 25 | 61 | 53 | 48 |
| | V2 | 745 | 4250 | 2877 | 731 | 23 | 5506 | 727 | 19 | 56 | 48 | 44 |
| | V3 | 629 | 3801 | 2560 | 652 | 19 | 4721 | 651 | 15 | 52 | 44 | 39 |
| | V4 | 574 | 3560 | 2380 | 612 | 16 | 4393 | 612 | 14 | 49 | 41 | 36 |
| | V5 | 454 | 2991 | 2083 | 515 | 12 | 3630 | 515 | 10 | 41 | 33 | 29 |
| 7020 | V1 | 1113 | 5700 | 4650 | 978 | 35.6 | 7630 | 978 | 27 | 65 | 57 | 52 |
| | V2 | 1036 | 5220 | 4050 | 894 | 29.6 | 6660 | 894 | 21.5 | 60 | 53 | 48 |
| | V3 | 774 | 4400 | 3360 | 755 | 22.0 | 5530 | 755 | 16.1 | 56 | 49 | 44 |
| | V4 | 657 | 3860 | 2930 | 662 | 17.3 | 4890 | 662 | 12.6 | 49 | 42 | 37 |
| | V5 | 528 | 3170 | 2390 | 544 | 12.2 | 4060 | 544 | 8.9 | 48 | 40 | 35 |
| 8020 | V1 | 1333 | 7858 | 6326 | 1347 | 42 | 9866 | 1346 | 36 | 66 | 58 | 54 |
| | V2 | 1035 | 6660 | 5301 | 1142 | 30 | 8442 | 1145 | 27 | 59 | 51 | 48 |
| | V3 | 905 | 5867 | 4646 | 1005 | 24 | 7641 | 1004 | 21 | 55 | 47 | 43 |
| | V4 | 769 | 5010 | 3973 | 861 | 18 | 6282 | 860 | 16 | 52 | 44 | 40 |
| | V5 | 644 | 4200 | 3328 | 720 | 13 | 5139 | 720 | 12 | 47 | 39 | 35 |
| 9020 | V1 | 1682 | 9310 | 7250 | 1599 | 60 | 12161 | 1598 | 54 | 70 | 62 | 57 |
| | V2 | 1473 | 8800 | 6620 | 1509 | 55 | 11150 | 1512 | 49 | 68 | 60 | 55 |
| | V3 | 1282 | 8220 | 6000 | 1412 | 48 | 10328 | 1411 | 43 | 65 | 57 | 52 |
| | V4 | 1026 | 7230 | 5140 | 1242 | 38 | 8824 | 1242 | 34 | 59 | 51 | 46 |
| | V5 | 756 | 6050 | 4200 | 1037 | 28 | 7364 | 1037 | 25 | 51 | 43 | 39 |

Noise data are given for wall or ceiling mounted units with cabinet.

The sound pressure levels Lp in dBA are based on (NR) characteristic of a room having volume of 100 m³ with reverberation time of 0.5 seconds (example : an office with carpet on floor).

Performances based on :

Summer : air 27 °C/19 °C (wet bulb) and chilled water 7/12 °C.

Winter : air 20 °C, entering water temperature 50 °C, water flow identical to cooling mode.

Pt : Total cooling capacity.

Ps : Sensible cooling capacity.

Pc : Heating capacity.

Lw : Sound power level.

Lp : Sound pressure level.

WPD : Water pressure drop.

 Standard wiring of the 3 speeds. Other speed combinations available upon request.

Aqu@Fan II performance data - 2-pipe system

■ 3-row main coil

| Sizes | Speeds | Air flow (m ³ /h) | Cooling | | | | Heating | | | Lw global (dBA) | Lp global (dBA) | NR/ISO |
|-------|--------|------------------------------|---------|--------|------------------|-----------|---------|------------------|-----------|-----------------|-----------------|--------|
| | | | Pt (W) | Ps (W) | Water flow (l/h) | WPD (kPa) | Pc (W) | Water flow (l/h) | WPD (kPa) | | | |
| 1030 | V1 | 166 | 1140 | 883 | 194 | 19 | 1584 | 194 | 16 | 48 | 40 | 35 |
| | V2 | 147 | 1065 | 807 | 184 | 16 | 1467 | 184 | 14 | 45 | 37 | 33 |
| | V3 | 126 | 955 | 711 | 162 | 13 | 1287 | 162 | 11 | 41 | 33 | 28 |
| | V4 | 108 | 830 | 615 | 144 | 11 | 1089 | 144 | 9 | 37 | 29 | 24 |
| | V5 | 90 | 715 | 520 | 122 | 8 | 929 | 122 | 7 | 33 | 25 | 19 |
| 2030 | V1 | 292 | 1871 | 1478 | 321 | 8 | 2527 | 321 | 8 | 53 | 45 | 41 |
| | V2 | 260 | 1745 | 1351 | 300 | 7 | 2388 | 300 | 7 | 49 | 41 | 37 |
| | V3 | 205 | 1465 | 1109 | 251 | 5 | 2021 | 251 | 5 | 43 | 35 | 31 |
| | V4 | 163 | 1255 | 925 | 216 | 4 | 1648 | 216 | 4 | 36 | 28 | 24 |
| | V5 | 122 | 1035 | 748 | 178 | 3 | 1244 | 178 | 3 | 34 | 26 | 22 |
| 3030 | V1 | 374 | 2441 | 1935 | 418 | 16 | 3396 | 417 | 13 | 56 | 48 | 44 |
| | V2 | 322 | 2338 | 1770 | 400 | 15 | 3020 | 400 | 12 | 52 | 44 | 40 |
| | V3 | 267 | 2134 | 1562 | 367 | 12 | 2613 | 367 | 11 | 48 | 40 | 36 |
| | V4 | 232 | 1918 | 1386 | 328 | 10 | 2290 | 327 | 9 | 45 | 37 | 33 |
| | V5 | 167 | 1524 | 1015 | 263 | 7 | 1743 | 263 | 6 | 37 | 29 | 24 |
| 4030 | V1 | 524 | 3463 | 2730 | 594 | 33 | 4570 | 594 | 28 | 52 | 44 | 39 |
| | V2 | 433 | 3075 | 2352 | 529 | 26 | 4176 | 529 | 22 | 47 | 39 | 35 |
| | V3 | 354 | 2620 | 1971 | 450 | 20 | 3499 | 450 | 17 | 42 | 34 | 29 |
| | V4 | 323 | 2465 | 1833 | 425 | 18 | 3233 | 425 | 15 | 40 | 32 | 27 |
| | V5 | 272 | 2190 | 1595 | 375 | 14 | 2687 | 374 | 12 | 37 | 29 | 24 |
| 5030 | V1 | 677 | 5010 | 3766 | 861 | 29 | 6131 | 861 | 24 | 55 | 47 | 43 |
| | V2 | 510 | 3770 | 2785 | 648 | 17 | 4828 | 648 | 15 | 48 | 40 | 37 |
| | V3 | 434 | 3330 | 2430 | 573 | 14 | 4205 | 572 | 12 | 44 | 36 | 32 |
| | V4 | 330 | 2659 | 1929 | 457 | 9 | 3456 | 458 | 8 | 39 | 31 | 27 |
| | V5 | 307 | 2495 | 1795 | 429 | 8 | 3209 | 428 | 7 | 37 | 29 | 23 |
| 6030 | V1 | 843 | 5730 | 3849 | 983 | 42 | 7360 | 983 | 35 | 61 | 53 | 48 |
| | V2 | 708 | 4940 | 3270 | 850 | 32 | 6180 | 849 | 27 | 56 | 48 | 44 |
| | V3 | 598 | 4390 | 2860 | 753 | 26 | 5250 | 752 | 22 | 52 | 44 | 39 |
| | V4 | 545 | 4080 | 2640 | 702 | 23 | 4848 | 702 | 19 | 49 | 41 | 36 |
| | V5 | 431 | 3395 | 2221 | 583 | 16 | 3992 | 583 | 14 | 42 | 34 | 30 |
| 7030 | V1 | 1058 | 7470 | 5930 | 1288 | 25 | 9180 | 1288 | 21 | 64 | 56 | 51 |
| | V2 | 984 | 6840 | 5170 | 1174 | 22 | 8406 | 1173 | 19 | 61 | 53 | 48 |
| | V3 | 735 | 5610 | 4171 | 965 | 16 | 6896 | 965 | 13 | 54 | 46 | 41 |
| | V4 | 624 | 4810 | 3560 | 825 | 12 | 6007 | 825 | 12 | 50 | 43 | 38 |
| | V5 | 502 | 3920 | 2889 | 673 | 8 | 4940 | 673 | 7 | 46 | 38 | 34 |
| 8030 | V1 | 1266 | 9038 | 6889 | 1548 | 39 | 11317 | 1548 | 33 | 66 | 58 | 54 |
| | V2 | 983 | 7590 | 5618 | 1304 | 29 | 9269 | 1303 | 24 | 59 | 51 | 48 |
| | V3 | 859 | 6649 | 4916 | 1142 | 23 | 8355 | 1141 | 19 | 56 | 48 | 44 |
| | V4 | 730 | 5677 | 4194 | 976 | 17 | 7113 | 975 | 14 | 53 | 45 | 41 |
| | V5 | 612 | 4749 | 3509 | 814 | 12 | 5985 | 814 | 10 | 49 | 41 | 36 |
| 9030 | V1 | 1598 | 10741 | 8290 | 1840 | 38 | 13977 | 1839 | 33 | 70 | 62 | 57 |
| | V2 | 1399 | 9980 | 7490 | 1714 | 34 | 12760 | 1714 | 28 | 68 | 60 | 55 |
| | V3 | 1218 | 9011 | 6742 | 1548 | 28 | 11541 | 1548 | 24 | 66 | 58 | 53 |
| | V4 | 974 | 7694 | 5649 | 1322 | 21 | 9802 | 1321 | 18 | 60 | 52 | 47 |
| | V5 | 719 | 6415 | 4526 | 1102 | 15 | 7527 | 1101 | 13 | 53 | 45 | 41 |

Noise data are given for wall or ceiling mounted units with cabinet.

The sound pressure levels Lp in dBA are based on (NR) characteristic of a room having volume of 100 m³ with reverberation time of 0.5 seconds (example : an office with carpet on floor).

Performances based on :

Summer : air 27 °C/19 °C (wet bulb) and chilled water 7/12 °C.

Winter : air 20 °C, entering water temperature 50 °C, water flow identical to cooling mode.

Pt : Total cooling capacity.

Ps : Sensible cooling capacity.

Pc : Heating capacity.

Lw : Sound power level.

Lp : Sound pressure level.

WPD : Water pressure drop.

 Standard wiring of the 3 speeds. Other speed combinations available upon request.

Aqu@Fan II performance data - 4-pipe system

■ 2-row cooling main coil + 1-row heating complementary coil

| Sizes | Speeds | Air flow (m ³ /h) | Cooling | | | | Heating | | | Lw global (dBA) | Lp global (dBA) | NR/ISO |
|-------|--------|---------------------------------|-----------|-----------|---------------------|--------------|-----------|---------------------|--------------|-----------------------|-----------------------|--------|
| | | | Pt (W) | Ps (W) | Water flow (l/h) | WPD (kPa) | Pc (W) | Water flow (l/h) | WPD (kPa) | | | |
| 1021 | V1 | 166 | 956 | 763 | 166 | 10 | 1464 | 129 | 2 | 48 | 40 | 35 |
| | V2 | 147 | 895 | 708 | 155 | 8 | 1383 | 121 | 2 | 45 | 37 | 33 |
| | V3 | 126 | 809 | 636 | 140 | 7 | 1278 | 112 | 2 | 41 | 33 | 28 |
| | V4 | 108 | 702 | 548 | 119 | 6 | 1158 | 102 | 1 | 37 | 29 | 24 |
| | V5 | 90 | 597 | 460 | 104 | 4 | 1022 | 90 | 1 | 33 | 25 | 19 |
| 2021 | V1 | 292 | 1679 | 1351 | 288 | 28 | 2500 | 219 | 6 | 53 | 45 | 41 |
| | V2 | 260 | 1551 | 1227 | 266 | 25 | 2410 | 212 | 5 | 49 | 41 | 37 |
| | V3 | 205 | 1304 | 1010 | 223 | 18 | 2139 | 188 | 4 | 43 | 35 | 31 |
| | V4 | 163 | 1108 | 835 | 191 | 13 | 1850 | 162 | 3 | 36 | 30 | 24 |
| | V5 | 141 | 928 | 688 | 158 | 10 | 1500 | 132 | 2 | 34 | 26 | 22 |
| 3021 | V1 | 374 | 2035 | 1722 | 349 | 7.6 | 3391 | 298 | 13.1 | 56 | 48 | 44 |
| | V2 | 322 | 1954 | 1589 | 335 | 7.1 | 3149 | 276 | 11.5 | 52 | 44 | 40 |
| | V3 | 267 | 1651 | 1342 | 284 | 6.0 | 2852 | 250 | 9.7 | 50 | 42 | 38 |
| | V4 | 232 | 1502 | 1193 | 257 | 5.2 | 2630 | 231 | 8.3 | 45 | 37 | 33 |
| | V5 | 167 | 1061 | 851 | 182 | 3.4 | 2200 | 193 | 6.1 | 39 | 31 | 26 |
| 4021 | V1 | 524 | 2920 | 2230 | 501 | 17 | 4732 | 415 | 29.5 | 52 | 44 | 39 |
| | V2 | 443 | 2569 | 1870 | 439 | 13 | 4300 | 378 | 25.0 | 47 | 39 | 35 |
| | V3 | 354 | 2174 | 1570 | 375 | 10 | 3799 | 333 | 19.9 | 43 | 35 | 30 |
| | V4 | 323 | 2056 | 1460 | 353 | 9 | 3590 | 315 | 18.0 | 40 | 32 | 27 |
| | V5 | 272 | 1841 | 1280 | 317 | 7 | 3270 | 287 | 15.4 | 37 | 29 | 24 |
| 5021 | V1 | 677 | 4230 | 3315 | 727 | 35 | 6380 | 560 | 51 | 55 | 47 | 43 |
| | V2 | 510 | 3157 | 2450 | 540 | 21 | 5500 | 483 | 39 | 48 | 40 | 37 |
| | V3 | 434 | 2827 | 2142 | 483 | 17 | 4970 | 436 | 33 | 44 | 36 | 32 |
| | V4 | 330 | 2265 | 1699 | 389 | 12 | 4179 | 366 | 24 | 39 | 31 | 27 |
| | V5 | 307 | 2131 | 1589 | 367 | 11 | 3950 | 346 | 22 | 37 | 29 | 23 |
| 6021 | V1 | 843 | 4762 | 3237 | 817 | 28 | 6749 | 592 | 16 | 61 | 53 | 48 |
| | V2 | 708 | 4120 | 2789 | 706 | 21 | 6190 | 543 | 14 | 56 | 48 | 44 |
| | V3 | 598 | 3679 | 2481 | 630 | 18 | 5710 | 501 | 12 | 52 | 44 | 39 |
| | V4 | 545 | 3439 | 2302 | 591 | 15 | 5420 | 476 | 11 | 49 | 41 | 36 |
| | V5 | 431 | 2882 | 2012 | 493 | 11 | 4670 | 409 | 8 | 42 | 34 | 30 |
| 7021 | V1 | 1058 | 5529 | 4495 | 950 | 33.8 | 7995 | 702 | 24.6 | 64 | 56 | 51 |
| | V2 | 984 | 5068 | 3932 | 871 | 28.3 | 7169 | 628 | 19.5 | 60 | 53 | 48 |
| | V3 | 735 | 4262 | 3246 | 730 | 20.8 | 6270 | 550 | 15.4 | 54 | 46 | 41 |
| | V4 | 624 | 3735 | 2830 | 640 | 16.3 | 5689 | 499 | 12.3 | 47 | 43 | 38 |
| | V5 | 502 | 3065 | 2309 | 526 | 11.5 | 4799 | 421 | 9.2 | 44 | 38 | 34 |
| 8021 | V1 | 1266 | 7622 | 6099 | 1307 | 40 | 11749 | 1032 | 49 | 66 | 58 | 54 |
| | V2 | 983 | 6440 | 5081 | 1106 | 28 | 10440 | 916 | 40 | 59 | 51 | 48 |
| | V3 | 859 | 5666 | 4459 | 972 | 23 | 9609 | 843 | 34 | 56 | 48 | 44 |
| | V4 | 730 | 4842 | 3814 | 832 | 17 | 8673 | 761 | 28 | 53 | 45 | 41 |
| | V5 | 612 | 4054 | 3190 | 695 | 12 | 7399 | 649 | 21 | 49 | 41 | 36 |
| 9021 | V1 | 1598 | 9055 | 7021 | 1552 | 57 | 14230 | 1248 | 74 | 70 | 62 | 57 |
| | V2 | 1399 | 8543 | 6405 | 1466 | 52 | 13452 | 1181 | 67 | 68 | 60 | 55 |
| | V3 | 1218 | 7967 | 5806 | 1368 | 46 | 12519 | 1098 | 59 | 66 | 58 | 53 |
| | V4 | 974 | 6977 | 4957 | 1196 | 36 | 10970 | 963 | 47 | 61 | 53 | 48 |
| | V5 | 719 | 5809 | 4035 | 997 | 26 | 9112 | 799 | 33 | 55 | 47 | 43 |

Noise data are given for wall or ceiling mounted units with cabinet.

The sound pressure levels Lp in dBA are based on (NR) characteristic of a room having volume of 100 m³ with reverberation time of 0.5 seconds (example : an office with carpet on floor).

Performances based on :

Summer : air 27 °C/19 °C (wet bulb) and chilled water 7/12 °C.

Winter : air 20 °C, hot water 70/60 °C.

Pt : Total cooling capacity.

Ps : Sensible cooling capacity.

Pc : Heating capacity.

Lw : Sound power level.

Lp : Sound pressure level.

WPD : Water pressure drop.

 Standard wiring of the 3 speeds. Other speed combinations available upon request.

Aqu@Fan II performance data - 4-pipe system

■ 3-row cooling main coil + 1-row heating complementary coil

| Sizes | Speeds | Air flow (m ³ /h) | Cooling | | | | Heating | | | Lw global (dBA) | Lp global (dBA) | NR/ISO |
|-------|--------|---------------------------------|-----------|-----------|---------------------|--------------|-----------|---------------------|--------------|-----------------------|-----------------------|--------|
| | | | Pt (W) | Ps (W) | Water flow (l/h) | WPD (kPa) | Pc (W) | Water flow (l/h) | WPD (kPa) | | | |
| 1031 | V1 | 161 | 1114 | 861 | 191 | 18 | 1439 | 126 | 2 | 48 | 40 | 35 |
| | V2 | 142 | 1037 | 784 | 176 | 16 | 1361 | 119 | 2 | 46 | 38 | 34 |
| | V3 | 122 | 931 | 691 | 158 | 13 | 1252 | 110 | 2 | 42 | 34 | 29 |
| | V4 | 104 | 804 | 595 | 137 | 10 | 1134 | 100 | 1 | 38 | 30 | 25 |
| | V5 | 87 | 695 | 505 | 119 | 8 | 1002 | 88 | 1 | 34 | 26 | 21 |
| 2031 | V1 | 283 | 1971 | 1518 | 338 | 42 | 2463 | 216 | 6 | 53 | 45 | 41 |
| | V2 | 251 | 1846 | 1390 | 317 | 37 | 2370 | 208 | 5 | 50 | 42 | 37 |
| | V3 | 224 | 1543 | 1141 | 266 | 27 | 2102 | 184 | 4 | 44 | 36 | 32 |
| | V4 | 199 | 1327 | 954 | 227 | 20 | 1812 | 159 | 3 | 37 | 29 | 25 |
| | V5 | 158 | 1075 | 755 | 184 | 14 | 1470 | 129 | 2 | 35 | 27 | 23 |
| 3031 | V1 | 362 | 2387 | 1882 | 411 | 15 | 3335 | 292 | 13 | 56 | 48 | 44 |
| | V2 | 311 | 2278 | 1718 | 389 | 14 | 3096 | 272 | 11 | 52 | 44 | 40 |
| | V3 | 258 | 2078 | 1515 | 356 | 12 | 2801 | 246 | 9 | 49 | 41 | 37 |
| | V4 | 225 | 1868 | 1349 | 320 | 10 | 2580 | 226 | 8 | 45 | 37 | 33 |
| | V5 | 162 | 1482 | 987 | 256 | 7 | 2157 | 189 | 6 | 38 | 30 | 25 |
| 4031 | V1 | 508 | 3398 | 2663 | 583 | 31 | 4544 | 398 | 25 | 52 | 44 | 39 |
| | V2 | 419 | 3007 | 2289 | 515 | 25 | 4227 | 371 | 22 | 47 | 39 | 35 |
| | V3 | 343 | 2560 | 1920 | 439 | 19 | 3732 | 327 | 17 | 42 | 34 | 30 |
| | V4 | 313 | 2409 | 1784 | 414 | 17 | 3517 | 309 | 16 | 40 | 32 | 27 |
| | V5 | 263 | 2128 | 1550 | 367 | 14 | 3207 | 281 | 13 | 37 | 29 | 24 |
| 5031 | V1 | 656 | 4894 | 3669 | 839 | 27 | 6277 | 550 | 50 | 55 | 47 | 43 |
| | V2 | 493 | 3676 | 2711 | 630 | 16 | 5398 | 474 | 38 | 48 | 40 | 37 |
| | V3 | 420 | 3247 | 2365 | 558 | 13 | 4875 | 428 | 32 | 45 | 37 | 33 |
| | V4 | 320 | 2593 | 1879 | 447 | 9 | 4095 | 359 | 23 | 39 | 31 | 27 |
| | V5 | 297 | 2427 | 1744 | 418 | 8 | 3870 | 340 | 21 | 37 | 29 | 24 |
| 6031 | V1 | 817 | 5614 | 3770 | 961 | 40 | 6651 | 583 | 15 | 61 | 53 | 48 |
| | V2 | 686 | 4836 | 3200 | 828 | 31 | 6091 | 534 | 13 | 56 | 48 | 44 |
| | V3 | 579 | 4289 | 2796 | 735 | 25 | 5614 | 493 | 11 | 54 | 46 | 42 |
| | V4 | 528 | 3984 | 2581 | 684 | 22 | 5327 | 468 | 10 | 51 | 43 | 38 |
| | V5 | 417 | 3305 | 2168 | 569 | 16 | 4589 | 403 | 8 | 43 | 35 | 30 |
| 7031 | V1 | 1024 | 7420 | 5640 | 1280 | 24 | 7880 | 690 | 24 | 64 | 56 | 51 |
| | V2 | 953 | 6680 | 5042 | 1145 | 21 | 7070 | 620 | 19 | 60 | 53 | 48 |
| | V3 | 712 | 5471 | 4055 | 940 | 15 | 6175 | 541 | 15 | 54 | 46 | 41 |
| | V4 | 604 | 4686 | 3460 | 803 | 11 | 5603 | 492 | 12 | 47 | 43 | 38 |
| | V5 | 486 | 3813 | 2808 | 655 | 8 | 4723 | 414 | 9 | 44 | 38 | 34 |
| 8031 | V1 | 1226 | 8833 | 6708 | 1516 | 38 | 11558 | 1014 | 48 | 66 | 58 | 54 |
| | V2 | 952 | 7402 | 5464 | 1271 | 28 | 10251 | 899 | 38 | 59 | 51 | 48 |
| | V3 | 832 | 6491 | 4779 | 1113 | 22 | 9429 | 828 | 33 | 57 | 49 | 45 |
| | V4 | 707 | 5537 | 4076 | 951 | 16 | 8141 | 714 | 25 | 54 | 46 | 42 |
| | V5 | 592 | 4627 | 3407 | 792 | 12 | 6745 | 592 | 18 | 49 | 41 | 36 |
| 9031 | V1 | 1547 | 10496 | 8092 | 1804 | 37 | 14011 | 1229 | 73 | 70 | 62 | 57 |
| | V2 | 1355 | 9758 | 7302 | 1674 | 32 | 13230 | 1160 | 65 | 68 | 60 | 55 |
| | V3 | 1180 | 8800 | 6568 | 1512 | 27 | 12300 | 1079 | 57 | 66 | 58 | 53 |
| | V4 | 944 | 7500 | 5491 | 1286 | 20 | 10763 | 944 | 45 | 61 | 53 | 48 |
| | V5 | 696 | 6228 | 4395 | 1069 | 14 | 8916 | 783 | 32 | 53 | 45 | 41 |

Noise data are given for wall or ceiling mounted units with cabinet.

The sound pressure levels Lp in dBA are based on (NR) characteristic of a room having volume of 100 m³ with reverberation time of 0.5 seconds (example : an office with carpet on floor).

Performances based on :

Summer : air 27 °C/19 °C (wet bulb) and chilled water 7/12 °C.

Winter : air 20 °C, hot water 70/60 °C.

Pt : Total cooling capacity.

Ps : Sensible cooling capacity.

Pc : Heating capacity.

Lw : Sound power level.

Lp : Sound pressure level.

WPD : Water pressure drop.

 Standard wiring of the 3 speeds. Other speed combinations available upon request.

Aqu@Fan II - Main controls

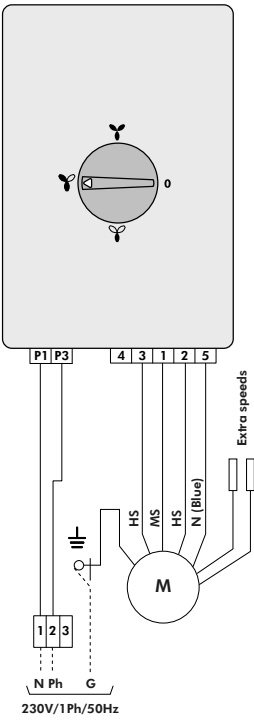
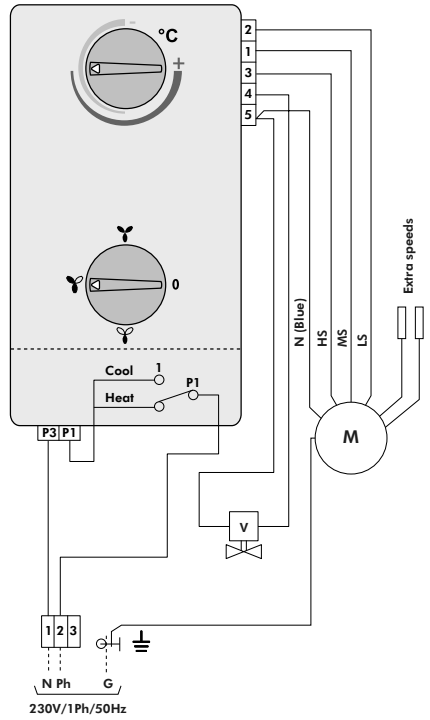
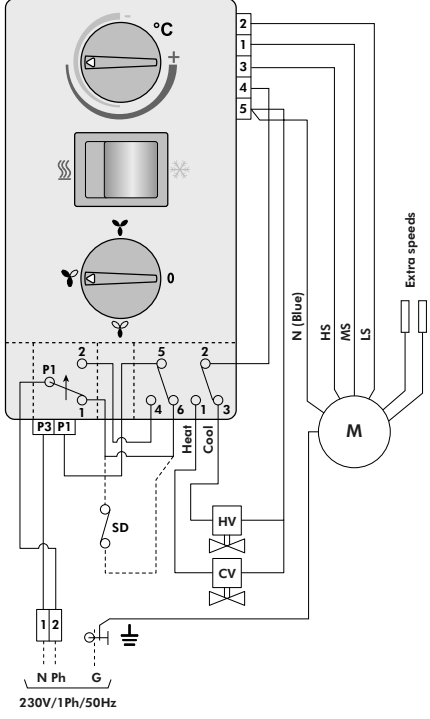
| | |
|--|--|
| <p>CMV (supplied fitted) Manual fan speed selector</p>  <p>The diagram shows a manual fan speed selector with a rotary knob and a 4-position switch. The switch terminals are labeled 1, 2, 3, 4, 5. Terminal 1 is connected to the fan motor (M) through a switch. Terminal 2 is connected to the fan motor through a switch. Terminal 3 is connected to the fan motor through a switch. Terminal 4 is connected to the fan motor through a switch. Terminal 5 is connected to the fan motor through a switch. The fan motor is connected to a 230V/1Ph/50Hz supply through a switch. The supply terminals are labeled N, Ph, G.</p> | <p>TBV (supplied fitted) Electromechanical control with valve</p>  <p>The diagram shows an electromechanical control with a thermostat and a 4-position manual speed selector. The thermostat has a temperature dial and a switch. The manual speed selector has a rotary knob and a 4-position switch. The switch terminals are labeled 1, 2, 3, 4, 5. Terminal 1 is connected to the fan motor (M) through a switch. Terminal 2 is connected to the fan motor through a switch. Terminal 3 is connected to the fan motor through a switch. Terminal 4 is connected to the fan motor through a switch. Terminal 5 is connected to the fan motor through a switch. The fan motor is connected to a 230V/1Ph/50Hz supply through a switch. The supply terminals are labeled N, Ph, G. The thermostat is connected to the fan motor through a switch. The thermostat terminals are labeled N (Blue), HS, MS, LS.</p> |
| <p>▶ 4 position manual fan speed selector : OFF/LS/MS/HS.</p> | <p>▶ Action on valve and fan, 2-pipe system in heating or cooling mode. ▶ Set of thermostat + 4-position manual speed selector : OFF/LS/MS/HS. ▶ Option TBV1 for action on valve only with constant fan operation. ▶ For reversible 2-pipe system with summer/winter automatic changeover, possibility of mounting with a water changeover sensor PCO, use of 4-way valve is mandatory.</p> |
| <p>TBMV (supplied fitted) Electromechanical control with valve(s)</p>  <p>The diagram shows an electromechanical control with a thermostat, a summer/winter switch, and a 4-position manual speed selector. The thermostat has a temperature dial and a switch. The summer/winter switch has a switch and a fan icon. The manual speed selector has a rotary knob and a 4-position switch. The switch terminals are labeled 1, 2, 3, 4, 5. Terminal 1 is connected to the fan motor (M) through a switch. Terminal 2 is connected to the fan motor through a switch. Terminal 3 is connected to the fan motor through a switch. Terminal 4 is connected to the fan motor through a switch. Terminal 5 is connected to the fan motor through a switch. The fan motor is connected to a 230V/1Ph/50Hz supply through a switch. The supply terminals are labeled N, Ph, G. The thermostat is connected to the fan motor through a switch. The thermostat terminals are labeled N (Blue), HS, MS, LS. The summer/winter switch is connected to the fan motor through a switch. The summer/winter switch terminals are labeled P1, P3, P1, 1, 2, 3, 4, 5, 6, 1, 2, 3.</p> | <p>▶ Action on valves and fan, 4-pipe, 2-pipe/2-wire or manual changeover 2-pipe system. ▶ Set of thermostat + summer/winter switch + 4-position manual speed selector: OFF/LS/MS/HS. ▶ Option TBMV1 for action on valve(s) only with constant fan operation. ▶ For 4-pipe or manual changeover 2-pipe system, possibility of mounting a low temperature cut-out sensor SD (temp. range 45 °C/35 °C) on hot water piping to stop fan operation.</p> |

Aqu@Fan II - Main controls (continued)

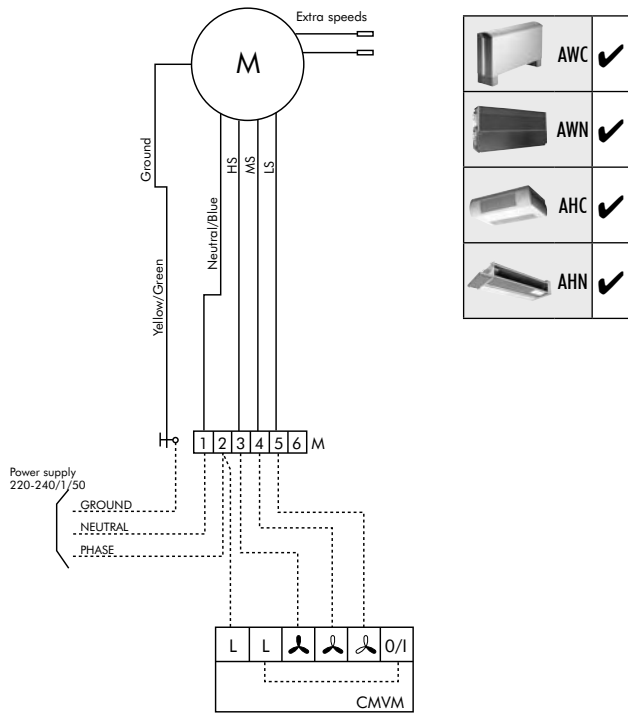
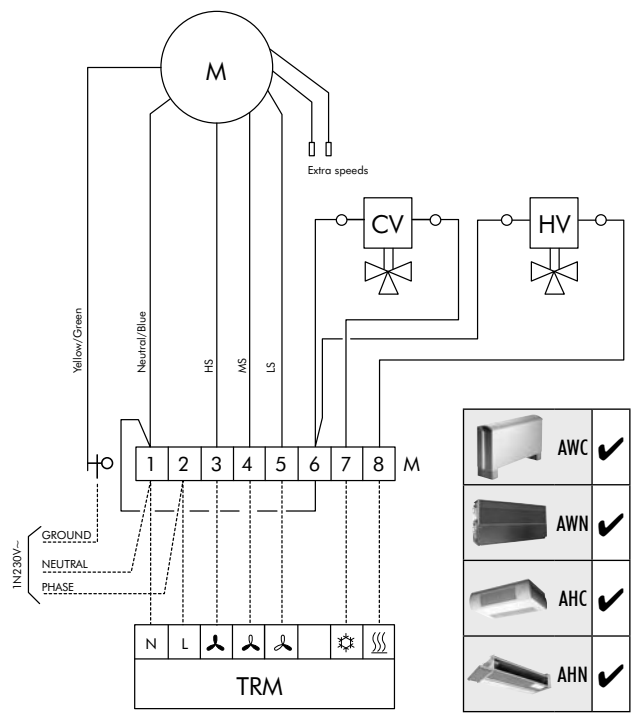
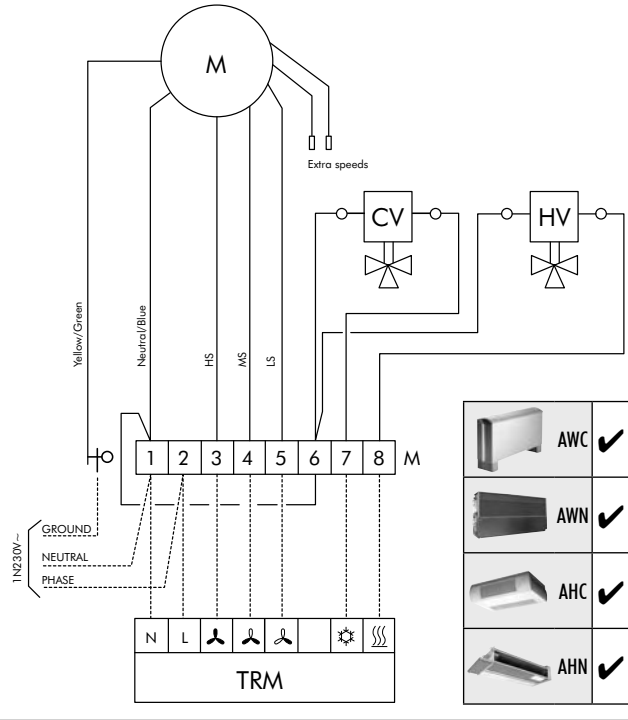
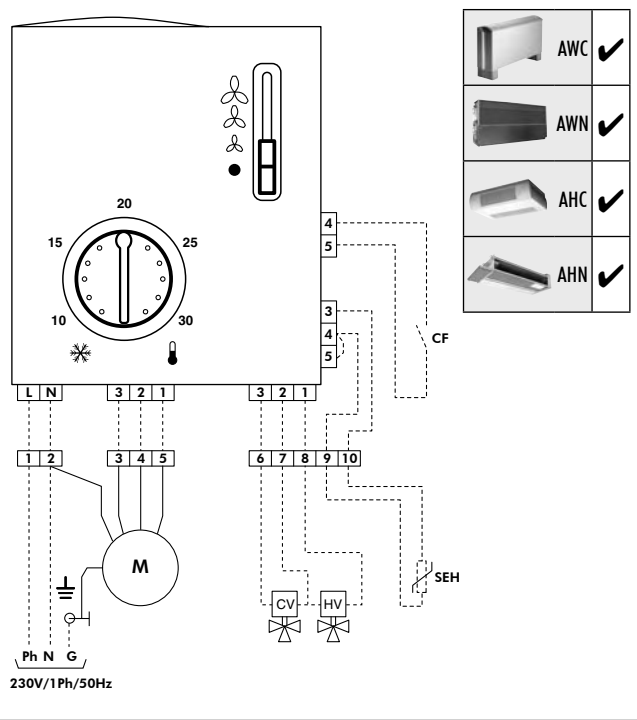
| | |
|---|---|
| <p>CMVM (supplied loose) Manual fan speed selector</p>  | <p>TRM-FA (supplied loose) Electromechanical remote control</p>  |
| <p>▶ 4 position manual fan speed selector : OFF/LS/MS/HS.</p> | <p>▶ Wall mounted remote thermostat to control valves and fan. ▶ Suitable for 4-pipe (with cooling and heating valves), 2-pipe/2-wire (with cooling valve and electric heater), 2-pipe (with cooling or heating valve) and reversible 2-pipe (with manual changeover) systems. ▶ Control buttons : ON/OFF; Summer/Winter changeover; Manual fan speed selector : LS/MS/HS.</p> |
| <p>TRM-VP (supplied loose) Electromechanical remote control</p>  | <p>TAE20 (supplied loose) Electronic remote thermostat</p>  |
| <p>▶ Wall mounted remote thermostat to regulate control valve(s). ▶ Suitable for 4-pipe (with cooling and heating valves), 2-pipe/2-wire (with cooling valve and electric heater), 2-pipe (with cooling or heating valve) and reversible 2-pipe (with manual changeover) systems. ▶ Control buttons : ON/OFF; Summer/Winter changeover; Manual fan speed selector : LS/MS/HS.</p> | <p>▶ Adjustable dead zone electronic thermostat with summer/winter automatic changeover. ▶ Suitable for 4-pipe (with cooling and heating valves), 2-pipe/2-wire (with cooling valve and electric heater (TAE 20BE)), 2-pipe (with cooling or heating valve) or reversible 2-pipe (with or without extra electric heating, 4-way valve mandatory and SEH changeover sensor) system. ▶ Controls buttons : ON/OFF, manual fan speed selector : LS/MS/HS, NO (normally open) or NC (normally closed) window contact CF.</p> |

Aqu@Fan II - Main controls (continued)

| | |
|---|--|
| <p>Aqu@Net communicating electronic control FCC electronic controller (supplied fitted)</p> | <p>RCL wire remote control with digital display (supplied loose or fitted)</p> |
| <ul style="list-style-type: none"> ▶ Controller can be configured in 2-pipe heating only or cooling only, 2-pipe/2-wire, reversible 2-pipe with or without extra electric heating or 4-pipe system. ▶ Other pre-programmed functionalities included : master/slaves up to 15 units controlled from one remote control only; NC window contact; automatic or manual selection of unoccupied mode; antifreeze mode. | <ul style="list-style-type: none"> ▶ Wire remote control for wall mounting or for mounting on AWC units. ▶ Keyboard with locking device and buttons : ON/Standby; fan operation (auto or manual); operation mode (cooling, heating, auto or fan operation only); temperature setpoint adjustment in different modes. ▶ Functioning LED. |
| <p>μBMS programmable supervision station (supplied loose)</p> | <p>Aqu@Net communicating electronic control System networking</p> |
| | |
| <ul style="list-style-type: none"> ▶ In association with FCC controllers through a communication bus and interface board (NIU), μBMS allows 15 different zones with 100 units to be managed. ▶ Other functionalities included either in global or individual control by zone : <ul style="list-style-type: none"> - Daily and weekly programming of running times (2 hour ranges), - Programming and setting of temperature setpoints (cooling, heating, auto), - Choice of operation mode (cooling, heating, auto or fan operation only), - Choice of fan operation speed (auto or manual). | <ul style="list-style-type: none"> ▶ RS485 communication bus system allowing user to monitor 100 fan coil units through a supervision station (μBMS), with FCC Aqu@Net controllers fitted with interface boards (NIU) and with local controls (RCL). Max. length of bus = 1000 meters, shielded twisted pair cable. |

Aqu@Fan II technical data

Air flow - 2-row dry coil

| Unit sizes | | 10 | 20 | 30 | 40 | 50 | 60 | 70 | 80 | 90 |
|------------|-------------------|-----|-----|-----|-----|-----|-----|------|------|------|
| Speed 1 | m ³ /h | 190 | 334 | 428 | 600 | 775 | 965 | 1210 | 1448 | 1828 |
| Speed 2 | m ³ /h | 168 | 297 | 368 | 495 | 583 | 810 | 1126 | 1125 | 1601 |
| Speed 3 | m ³ /h | 144 | 235 | 305 | 405 | 496 | 684 | 841 | 983 | 1394 |
| Speed 4 | m ³ /h | 123 | 187 | 266 | 370 | 378 | 624 | 690 | 836 | 1115 |
| Speed 5 | m ³ /h | 103 | 139 | 191 | 311 | 351 | 493 | 574 | 700 | 822 |

Electrical data 230 V/1 Ph/50 Hz (tolerance on voltage $\pm 10\%$)

| Unit sizes | | 10 | 20 | 30 | 40 | 50 | 60 | 70 | 80 | 90 |
|---------------------------------|----|------|------|------|------|------|-----|-----|------|-----|
| Max. running absorbed power (W) | V1 | 34 | 45 | 60 | 57 | 66 | 107 | 150 | 188 | 291 |
| | V2 | 28 | 37 | 49 | 47 | 50 | 81 | 130 | 132 | 222 |
| | V3 | 24 | 27 | 40 | 39 | 45 | 64 | 110 | 112 | 200 |
| | V4 | 20 | 19 | 33 | 36 | 40 | 55 | 101 | 101 | 165 |
| | V5 | 17 | 16 | 24 | 33 | 39 | 41 | 92 | 90 | 140 |
| Max. absorbed current (A) | | 0.13 | 0.17 | 0.28 | 0.27 | 0.31 | 0.5 | 0.7 | 0.95 | 1.5 |

Computer fan-coil selection by Win'R III software



To provide optimal fan-coil unit selection, Wesper supplies computer selection capability. The Win'R III selection program will select the most economical unit size to meet the specification. To operate the Win'R III software, the user needs a microcomputer using Windows 98SE, XP or 2000. Contact your nearest Wesper representative for a copy of Win'R III software or for a unit selection that meets the most exacting specifications.

Airwell

As part of our ongoing product improvement programme, our products are subject to change without prior notice. Non contractual photos.



CAC Export Department
 42 cours Jean-Jaurès
 17800 Pons - France
 Tel. : +33 (0)5 46 92 33 33 - Fax : +33 (0)5 46 91 26 44

Your distributor :